

## 1Mx8 LOW VOLTAGE, ULTRA LOW POWER CMOS STATIC RAM

### KEY FEATURES

- High-speed access time: 45ns, 55ns
- CMOS low power operation
  - 36 mW (typical) operating
  - 12  $\mu$ W (typical) CMOS standby
- TTL compatible interface levels
- Single power supply
  - 1.65V-2.2V  $V_{DD}$  (62/65WV10248EALL)
  - 2.2V-3.6V  $V_{DD}$  (62/65WV10248EBLL)
- Data control for upper and lower bytes
- Automotive temperature (-40°C to +125°C)
- Lead-free available

### DESCRIPTION

The ISSI IS62WV10248EALL/ IS62WV10248EBLL are high-speed, 8M bit static RAMs organized as 1M words by 8 bits. It is fabricated using ISSI's high-performance CMOS technology. This highly reliable process coupled with innovative circuit design techniques, yields high-performance and low power consumption devices.

When  $\overline{CS1}$  is HIGH (deselected) or when CS2 is low (deselected), the device assumes a standby mode at which the power dissipation can be reduced down with CMOS input levels.

Easy memory expansion is provided by using Chip Enable and Output Enable inputs. The active LOW Write Enable ( $\overline{WE}$ ) controls both writing and reading of the memory.

The IS62WV10248EALL and IS62WV10248EBLL are packaged in the JEDEC standard 48-pin mini BGA (6mm x 8mm) and 44-Pin TSOP (TYPE II).

### BLOCK DIAGRAM

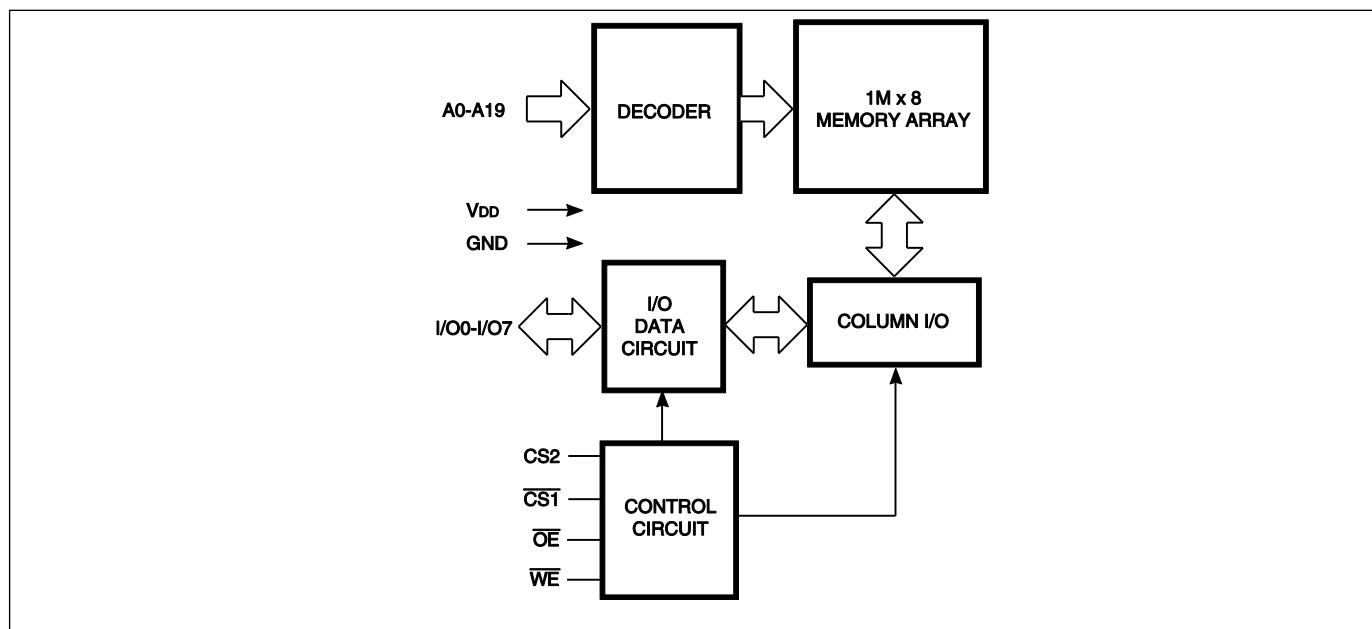

Copyright © 2014 Integrated Silicon Solution, Inc. All rights reserved. ISSI reserves the right to make changes to this specification and its products at any time without notice. ISSI assumes no liability arising out of the application or use of any information, products or services described herein. Customers are advised to obtain the latest version of this device specification before relying on any published information and before placing orders for products.

Integrated Silicon Solution, Inc. does not recommend the use of any of its products in life support applications where the failure or malfunction of the product can reasonably be expected to cause failure of the life support system or to significantly affect its safety or effectiveness. Products are not authorized for use in such applications unless Integrated Silicon Solution, Inc. receives written assurance to its satisfaction, that:

- a.) the risk of injury or damage has been minimized;
- b.) the user assume all such risks; and
- c.) potential liability of Integrated Silicon Solution, Inc is adequately protected under the circumstances

**PIN CONFIGURATIONS (1Mx8)**

48-pin mini BGA (B) (6mm x 8mm)

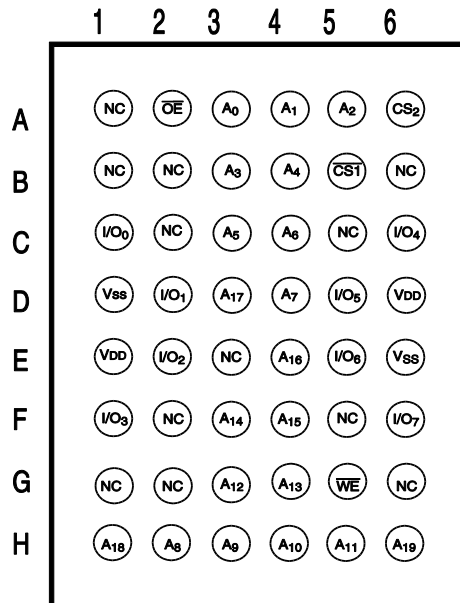

44-Pin TSOP (Type II)

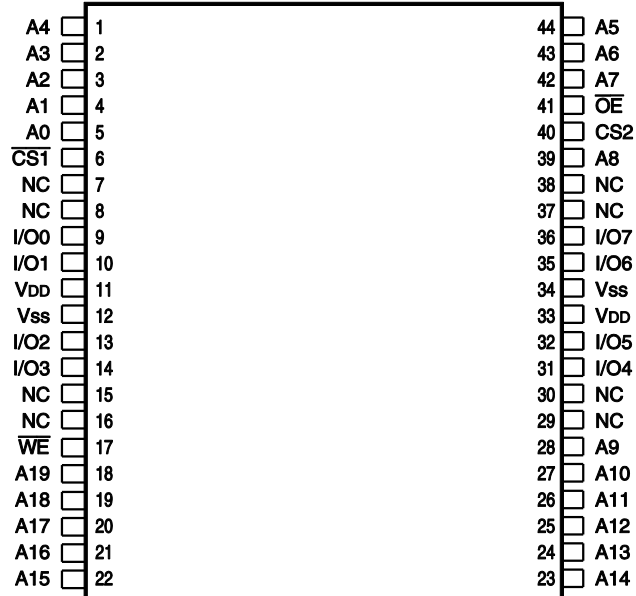

**PIN DESCRIPTIONS**

A0-A19	Address Inputs
$\overline{CS1}$	Chip Enable 1 Input
CS2	Chip Enable 2 Input
$\overline{OE}$	Output Enable Input
$\overline{WE}$	Write Enable Input
I/O0-I/O7	Input/Output
NC	No Connection
VDD	Power
VSS	Ground

## FUNCTION DESCRIPTION

SRAM is one of random access memories. Each byte has an address and can be accessed randomly. SRAM has three different modes supported. Each function is described below with Truth Table.

### STANDBY MODE

Device enters standby mode when deselected ( $\overline{CS1}$  HIGH or CS2 LOW). The input and output pins (I/O0-7) are placed in a high impedance state. The current consumption in this mode will be either ISB1 or ISB2 depending on the input level. CMOS input in this mode will maximize saving power.

### WRITE MODE

Write operation issues with Chip selected ( $\overline{CS1}$  LOW and CS2 HIGH) and Write Enable ( $\overline{WE}$ ) input LOW. The input and output pins(I/O0-7) are in data input mode. Output buffers are closed during this time even if  $\overline{OE}$  is LOW.

### READ MODE

Read operation issues with Chip selected ( $\overline{CS1}$  LOW and CS2 HIGH) and Write Enable ( $\overline{WE}$ ) input HIGH. When  $\overline{OE}$  is LOW, output buffer turns on to make data output. Any input to I/O pins during READ mode is not permitted.

In the READ mode, output buffers can be turned off by pulling  $\overline{OE}$  HIGH. In this mode, internal device operates as READ but I/Os are in a high impedance state. Since device is in READ mode, active current is used.

## TRUTH TABLE

Mode	$\overline{WE}$	$\overline{CS1}$	CS2	$\overline{OE}$	I/O Operation	VDD Current
Not Selected	X	H	X	X	High-Z	ISB1, ISB2
(Power-down)	X	X	L	X	High-Z	ISB1, ISB2
Output Disabled	H	L	H	H	High-Z	Icc
Read	H	L	H	L	Dout	Icc
Write	L	L	H	X	Din	Icc

**ABSOLUTE MAXIMUM RATINGS AND OPERATING RANGE**

**ABSOLUTE MAXIMUM RATINGS<sup>(1)</sup>**

Symbol	Parameter	Value	Unit
V <sub>term</sub>	Terminal Voltage with Respect to GND	-0.2 to +3.9(V <sub>DD</sub> +0.3V)	V
t <sub>BIAS</sub>	Temperature Under Bias	-55 to +125	°C
V <sub>DD</sub>	V <sub>DD</sub> Related to GND	-0.2 to +3.9(V <sub>DD</sub> +0.3V)	V
t <sub>Stg</sub>	Storage Temperature	-65 to +150	°C
I <sub>OUT</sub>	DC Output Current (LOW)	20	mA

Notes:

Stress greater than those listed under ABSOLUTE MAXIMUM RATINGS may cause permanent damage to the device. This is a stress rating only and functional operation of the device at these or any other conditions above those indicated in the operational sections of this specification is not implied. Exposure to absolute maximum rating conditions for extended periods may affect reliability.

**OPERATING RANGE<sup>(1)</sup>**

Range	Device Marking	Ambient Temperature	V <sub>DD</sub> (min)	V <sub>DD</sub> (typ)	V <sub>DD</sub> (max)
Commercial	IS62WV10248EALL	0°C to +70°C	1.65V	1.8V	2.2V
Industrial	IS62WV10248EALL	-40°C to +85°C	1.65V	1.8V	2.2V
Automotive	IS65WV10248EALL	-40°C to +125°C	1.65V	1.8V	2.2V
Commercial	IS62WV10248EBLL	0°C to +70°C	2.2V	3.3V	3.6V
Industrial	IS62WV10248EBLL	-40°C to +85°C	2.2V	3.3V	3.6V
Automotive	IS65WV10248EBLL	-40°C to +125°C	2.2V	3.3V	3.6V

Note:

1. Full device AC operation assumes a 100 μs ramp time from 0 to V<sub>CC</sub>(min) and 200 μs wait time after V<sub>CC</sub> stabilization.

**PIN CAPACITANCE<sup>(1)</sup>**

Parameter	Symbol	Test Condition	Max	Units
Input capacitance	C <sub>IN</sub>	T <sub>A</sub> = 25°C, f = 1 MHz, V <sub>DD</sub> = V <sub>DD</sub> (typ)	10	pF
DQ capacitance (IO0–IO7)	C <sub>I/O</sub>		10	pF

Note:

1. These parameters are guaranteed by design and tested by a sample basis only.

**THERMAL CHARACTERISTICS<sup>(1)</sup>**

Parameter	Symbol	Rating	Units
Thermal resistance from junction to ambient (airflow = 1m/s)	R <sub>θJA</sub>	43.22	°C/W
Thermal resistance from junction to case	R <sub>θJC</sub>	13.35	°C/W

Note:

1. These parameters are guaranteed by design and tested by a sample basis only.

**ELECTRICAL CHARACTERISTICS**

**IS62(5)WV10248EALL DC ELECTRICAL CHARACTERISTICS-I (OVER THE OPERATING RANGE)**

Symbol	Parameter	Test Conditions	Min.	Max.	Unit
$V_{OH}$	Output HIGH Voltage	$I_{OH} = -0.1 \text{ mA}$	1.4	—	V
$V_{OL}$	Output LOW Voltage	$I_{OL} = 0.1 \text{ mA}$	—	0.2	V
$V_{IH}^{(1)}$	Input HIGH Voltage		1.4	$V_{DD} + 0.2$	V
$V_{IL}^{(1)}$	Input LOW Voltage		-0.2	0.4	V
$I_{LI}$	Input Leakage	$GND < V_{IN} < V_{DD}$	-1	1	$\mu\text{A}$
$I_{LO}$	Output Leakage	$GND < V_{IN} < V_{DD}$ , Output Disabled	-1	1	$\mu\text{A}$

Notes:

- $V_{ILL}(\text{min}) = -1.0\text{V AC}$  (pulse width < 10ns). Not 100% tested.  
 $V_{IHH}(\text{max}) = V_{DD} + 1.0\text{V AC}$  (pulse width < 10ns). Not 100% tested.

**IS62(5)WV10248EBLL DC ELECTRICAL CHARACTERISTICS-I (OVER THE OPERATING RANGE)**

Symbol	Parameter	Test Conditions	Min.	Max.	Unit
$V_{OH}$	Output HIGH Voltage	$2.2 \leq V_{DD} < 2.7$ , $I_{OH} = -0.1 \text{ mA}$	2.0	—	V
		$2.7 \leq V_{DD} \leq 3.6$ , $I_{OH} = -1.0 \text{ mA}$	2.4	—	V
$V_{OL}$	Output LOW Voltage	$2.2 \leq V_{DD} < 2.7$ , $I_{OL} = 0.1 \text{ mA}$	—	0.4	V
		$2.7 \leq V_{DD} \leq 3.6$ , $I_{OL} = 2.1 \text{ mA}$	—	0.4	V
$V_{IH}^{(1)}$	Input HIGH Voltage	$2.2 \leq V_{DD} < 2.7$	1.8	$V_{DD} + 0.3$	V
		$2.7 \leq V_{DD} \leq 3.6$	2.2	$V_{DD} + 0.3$	V
$V_{IL}^{(1)}$	Input LOW Voltage	$2.2 \leq V_{DD} < 2.7$	-0.3	0.6	V
		$2.7 \leq V_{DD} \leq 3.6$	-0.3	0.8	V
$I_{LI}$	Input Leakage	$GND < V_{IN} < V_{DD}$	-1	1	$\mu\text{A}$
$I_{LO}$	Output Leakage	$GND < V_{IN} < V_{DD}$ , Output Disabled	-1	1	$\mu\text{A}$

Notes:

- $V_{ILL}(\text{min}) = -2.0\text{V AC}$  (pulse width < 10ns). Not 100% tested.  
 $V_{IHH}(\text{max}) = V_{DD} + 2.0\text{V AC}$  (pulse width < 10ns). Not 100% tested.

**IS62(5)WV10248EALL DC ELECTRICAL CHARACTERISTICS-II FOR POWER  
(OVER THE OPERATING RANGE)**

Symbol	Parameter	Test Conditions	Grade	Typ.	Max.	Unit
ICC	V <sub>DD</sub> Dynamic Operating Supply Current	V <sub>DD</sub> =V <sub>DD</sub> (max), I <sub>OUT</sub> =0mA, f=f <sub>MAX</sub>	Com.	-	12	mA
			Ind.	-	15	
			Auto.	-	15	
ICC1	V <sub>DD</sub> Static Operating Supply Current	V <sub>DD</sub> =V <sub>DD</sub> (max), I <sub>OUT</sub> = 0mA, f=0Hz	Com.	-	6	mA
			Ind.	-	6	
			Auto.	-	6	
ISB1	CMOS Standby Current (CMOS Inputs)	V <sub>DD</sub> =V <sub>DD</sub> (max), (1) 0V ≤ CS2 ≤ 0.2V or (2) $\overline{CS1} \geq V_{DD} - 0.2V$ , CS2 ≥ V <sub>DD</sub> - 0.2V	Com.	-	20	μA
			Ind.	-	25	μA
			Auto.	-	50	μA

Note:

Typical values are included for reference only and are not guaranteed or tested. Typical values are measured at VDD = VDD(typ), TA = 25°C

**IS62(5)WV10248EBLL DC ELECTRICAL CHARACTERISTICS-II FOR POWER  
(OVER THE OPERATING RANGE)**

Symbol	Parameter	Test Conditions	Grade	Typ.	Max.	Unit
ICC	V <sub>DD</sub> Dynamic Operating Supply Current	V <sub>DD</sub> =V <sub>DD</sub> (max), I <sub>OUT</sub> =0mA, f=f <sub>MAX</sub>	Com.	-	15	mA
			Ind.	-	15	
			Auto.	-	15	
ICC1	V <sub>DD</sub> Static Operating Supply Current	V <sub>DD</sub> =V <sub>DD</sub> (max), I <sub>OUT</sub> = 0mA, f=0Hz	Com.	-	6	mA
			Ind.	-	6	
			Auto.	-	6	
ISB1	CMOS Standby Current (CMOS Inputs)	V <sub>DD</sub> =V <sub>DD</sub> (max), (1) 0V ≤ CS2 ≤ 0.2V or (2) $\overline{CS1} \geq V_{DD} - 0.2V$ , CS2 ≥ V <sub>DD</sub> - 0.2V	Com.	-	20	μA
			Ind.	-	25	μA
			Auto.	-	50	μA

Note:

Typical values are included for reference only and are not guaranteed or tested. Typical values are measured at VDD = VDD(typ), TA = 25°C

**AC TEST CONDITIONS (OVER THE OPERATING RANGE)**

Parameter	Symbol	Conditions	Units
Input Rise Time	$T_R$	1.0	V/ns
Input Fall Time	$T_F$	1.0	V/ns
Output Timing Reference Level	$V_{REF}$	$\frac{1}{2} V_{TM}$	V
Output Load Conditions	Refer to Figure 1 and 2		

**OUTPUT LOAD CONDITIONS FIGURES**

Figure1

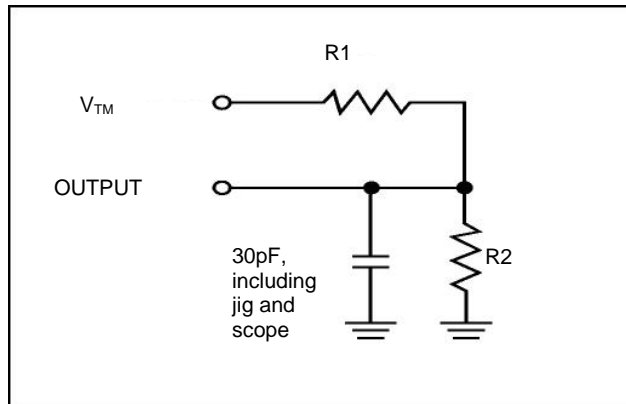
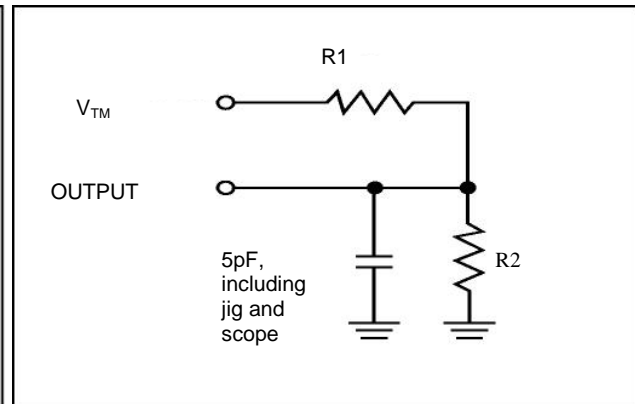

Figure2



Parameters	$V_{DD}=1.65\sim 1.98V$	$V_{DD}=2.2\sim 2.7V$	$V_{DD}=2.7\sim 3.6V$
R1	13500 $\Omega$	16667 $\Omega$	1103 $\Omega$
R2	10800 $\Omega$	15385 $\Omega$	1554 $\Omega$
$V_{TM}$	VDD	VDD	VDD

AC CHARACTERISTICS<sup>(6)</sup> (OVER OPERATING RANGE)

READ CYCLE AC CHARACTERISTICS

Parameter	Symbol	45ns		55ns		unit	notes
		Min	Max	Min	Max		
Read Cycle Time	tRC	45	-	55	-	ns	1,5
Address Access Time	tAA	-	45	-	55	ns	1
Output Hold Time	tOHA	8	-	8	-	ns	1
$\overline{CS1}$ , CS2 Access Time	tACS1/tACS2	-	45	-	55	ns	1
$\overline{OE}$ Access Time	tDOE	-	22	-	25	ns	1
$\overline{OE}$ to High-Z Output	tHZOE	-	18	-	18	ns	2
$\overline{OE}$ to Low-Z Output	tLZOE	5	-	5	-	ns	2
$\overline{CS1}$ , CS2 to High-Z Output	tHZCS/tHZCS2	-	18	-	18	ns	2
$\overline{CS1}$ , CS2 to Low-Z Output	tLZCS/tLZCS2	10	-	10	-	ns	2

WRITE CYCLE AC CHARACTERISTICS

Parameter	Symbol	45ns		55ns		unit	notes
		Min	Max	Min	Max		
Write Cycle Time	tWC	45	-	55	-	ns	1,3,5
$\overline{CS1}$ , CS2 to Write End	tSCS1/tSCS2	35	-	40	-	ns	1,3
Address Setup Time to Write End	tAW	35	-	40	-	ns	1,3
Address Hold from Write End	tHA	0	-	0	-	ns	1,3
Address Setup Time	tSA	0	-	0	-	ns	1,3
$\overline{WE}$ Pulse Width	tPWE	35	-	40	-	ns	1,3,4
Data Setup to Write End	tSD	28	-	28	-	ns	1,3
Data Hold from Write End	tHD	0	-	0	-	ns	1,3
$\overline{WE}$ LOW to High-Z Output	tHZWE	-	18	-	18	ns	2,3
$\overline{WE}$ HIGH to Low-Z Output	tLZWE	10	-	10	-	ns	2,3

Notes:

1. Tested with the load in Figure 1.
2. Tested with the load in Figure 2. tHZOE, tHZCS and tHZWE transitions are measured when the output enters a high impedance state. Not 100% tested.
3. The internal write time is defined by the overlap of  $\overline{CS1}$ =LOW, CS2=HIGH and  $\overline{WE}$ =LOW. All four conditions must be in valid states to initiate a Write, but any condition can go inactive to terminate the Write. The Data Input Setup and Hold timing are referenced to the rising or falling edge of the signal that terminates the write.
4. tPWE > tHZWE + tSD when OE is LOW.
5. Address inputs must meet V<sub>IH</sub> and V<sub>IL</sub> SPEC during this period. Any glitch or unknown inputs are not permitted. Unknown input with standby mode is acceptable.
6. Data retention characteristics are defined later in DATA RETENTION CHARACTERISTICS.



**TIMING DIAGRAM**

**READ CYCLE NO. 1<sup>(1,2)</sup> (ADDRESS CONTROLLED) ( $\overline{CS1}=\overline{OE}=V_{IL}$ ,  $CS2=\overline{WE}=V_{IH}$ )**

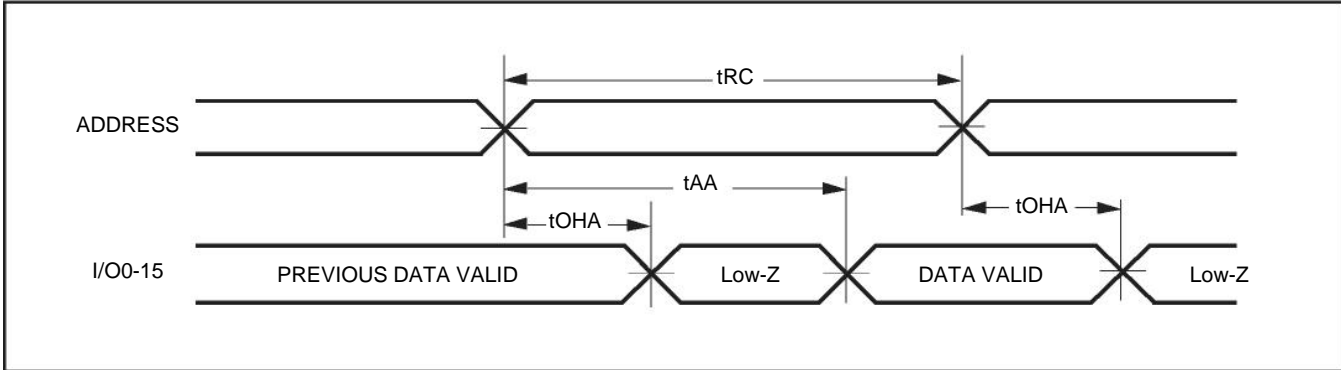

**READ CYCLE NO. 2<sup>(1,3)</sup> ( $\overline{CS1}$ ,  $CS2$ , AND  $\overline{OE}$  CONTROLLED)**

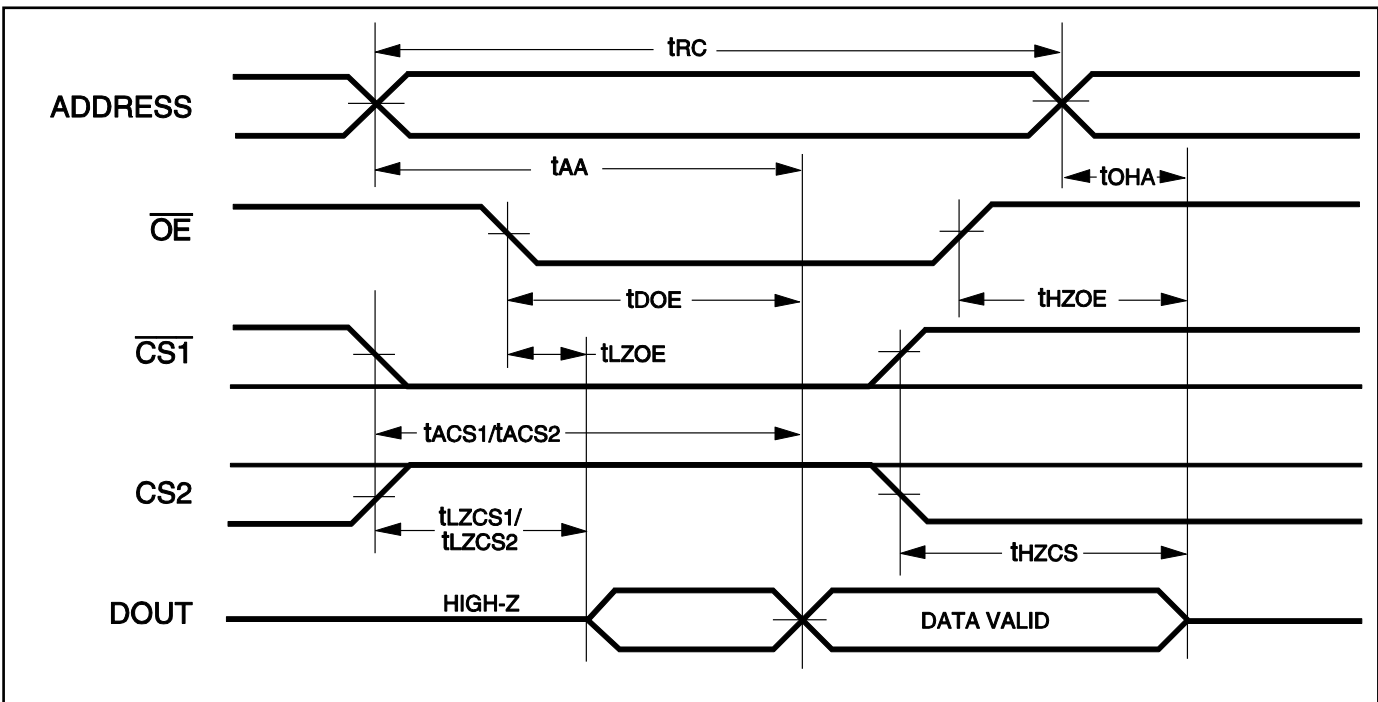

Notes:

1.  $\overline{WE}$  is HIGH for a Read Cycle.
2. The device is continuously selected.  $\overline{OE}$ ,  $\overline{CS1}=V_{IL}$ .  $CS2=\overline{WE}=V_{IH}$ .
3. Address is valid prior to or coincident with  $\overline{CS1}$  LOW and  $CS2$  HIGH transition.

WRITE CYCLE NO. 1 ( $\overline{CS1}$  CONTROLLED,  $\overline{OE}$  = HIGH OR LOW)

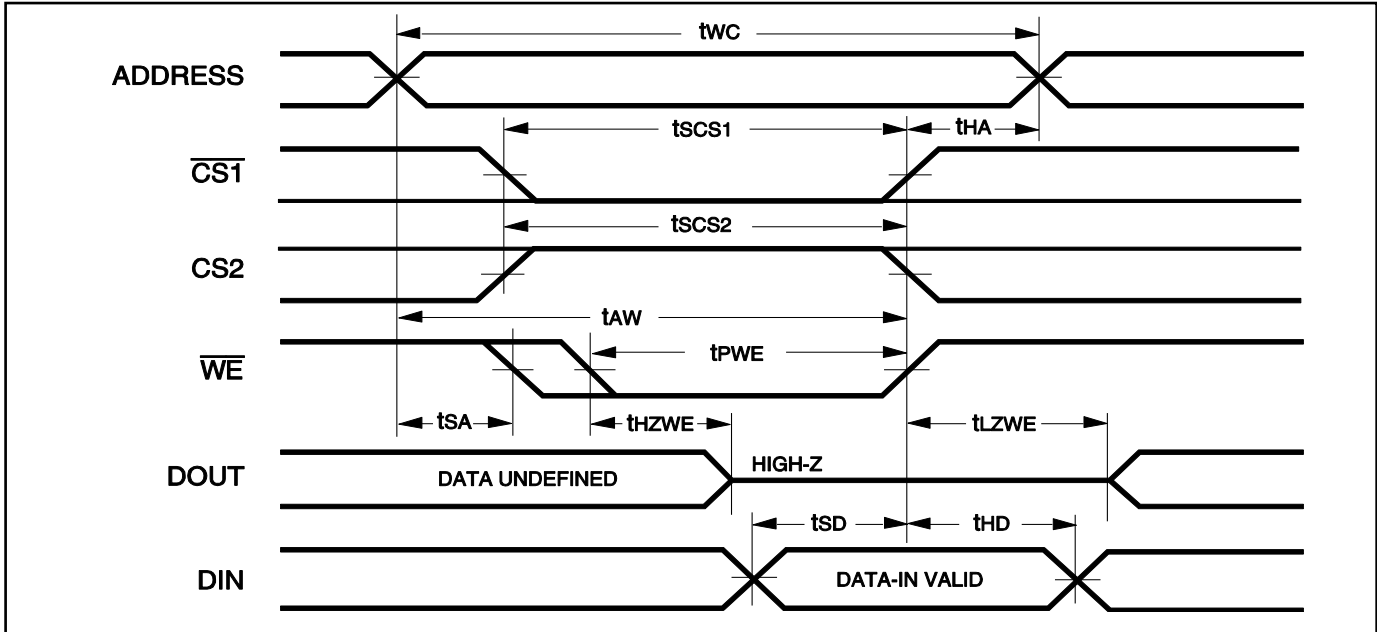

Notes:

1. tHZWE is based on the assumption when tSA=0nS after READ operation. Actual DOUT for tHZWE may not appear if  $\overline{OE}$  goes high before Write Cycle. tHZOE is the time DOUT goes to High-Z after  $\overline{OE}$  goes high.
2. During this period the I/Os are in output state. Do not apply input signals.

WRITE CYCLE NO. 2 ( $\overline{WE}$  Controlled:  $\overline{OE}$  is HIGH During Write Cycle)

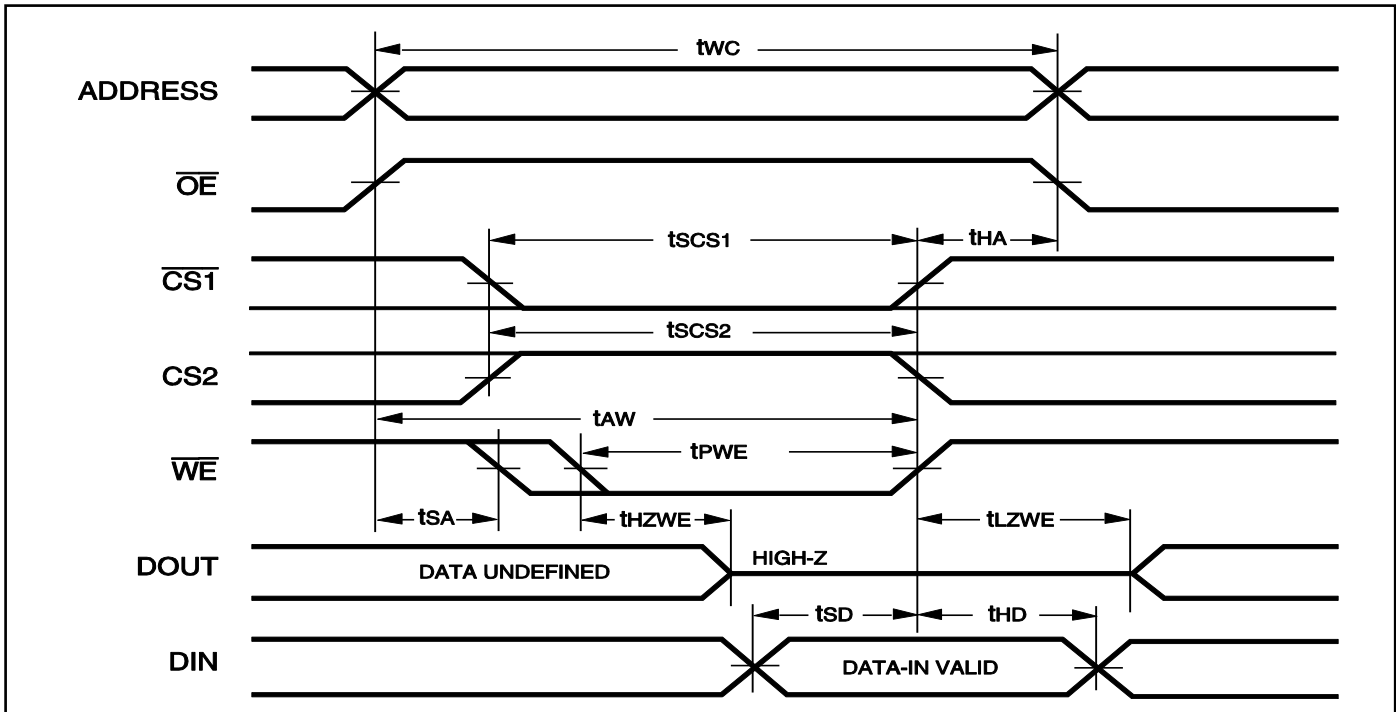

Notes:

1. tHZWE is based on the assumption when tSA=0nS after READ operation. Actual DOUT for tHZWE may not appear if  $\overline{OE}$  goes high before Write Cycle. tHZOE is the time DOUT goes to High-Z after  $\overline{OE}$  goes high.
2. During this period the I/Os are in output state. Do not apply input signals

WRITE CYCLE NO. 3 ( $\overline{WE}$  CONTROLLED:  $\overline{OE}$  IS LOW DURING WRITE CYCLE)

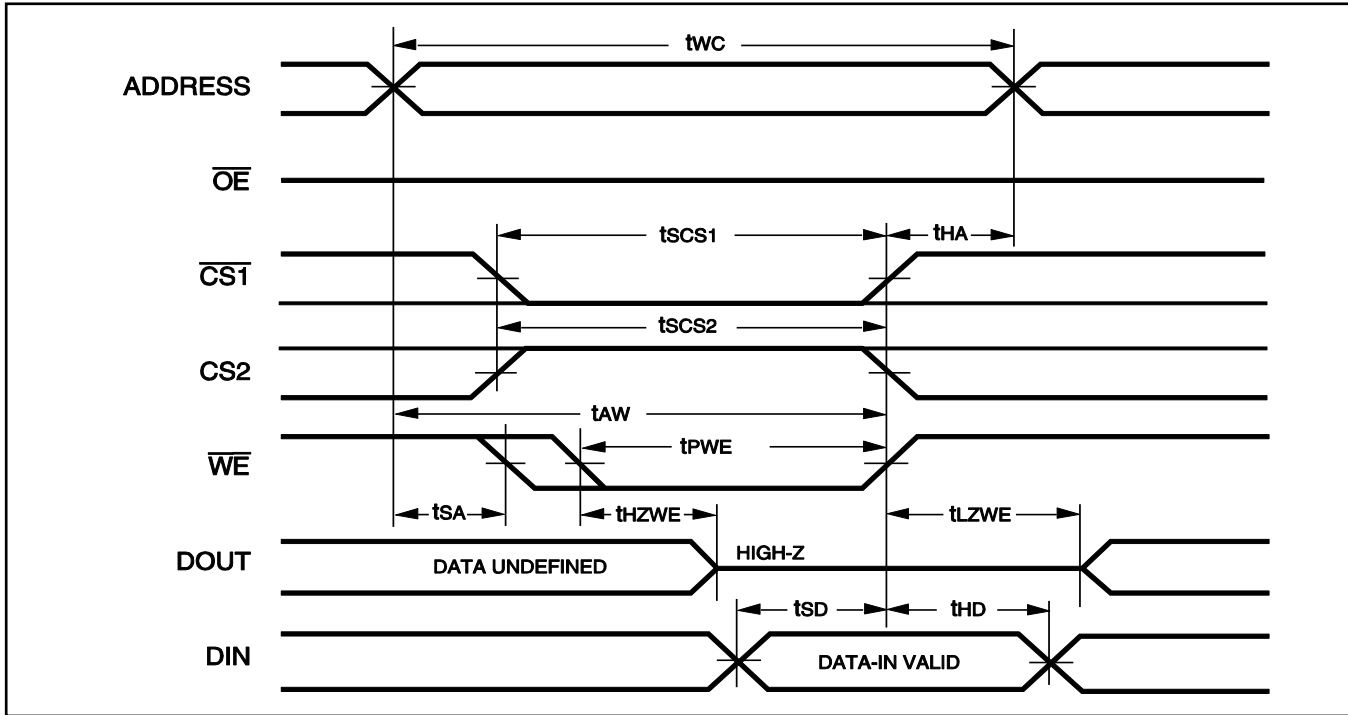

Notes:

If  $\overline{OE}$  is low during write cycle,  $t_{HZWE}$  must be met in the application. Do not apply input signal during this period. Data output from the previous READ operation will drive IO BUS.

**DATA RETENTION CHARACTERISTICS**

Symbol	Parameter	Test Condition	OPTION	Min.	Typ. <sup>(1)</sup>	Max.	Unit
V <sub>DR</sub>	V <sub>DD</sub> for Data Retention	See Data Retention Waveform	IS62(5)WV10248EALL	1.5		-	V
			IS62(5)WV10248EBLL	1.5		-	V
I <sub>DR</sub>	Data Retention Current	V <sub>DD</sub> = V <sub>DR</sub> (min), (1) 0V ≤ CS2 ≤ 0.2V, or (2) $\overline{CS1} \geq V_{DD} - 0.2V$ , CS2 ≥ V <sub>DD</sub> - 0.2V	Com.	-	-	20	uA
			Ind.	-	-	25	
			Auto	-	-	50	
t <sub>SDR</sub>	Data Retention Setup Time	See Data Retention Waveform		0	-	-	ns
t <sub>RDR</sub>	Recovery Time	See Data Retention Waveform		t <sub>RC</sub>	-	-	ns

Note:

1. Typical values are measured at V<sub>DD</sub>=V<sub>DR</sub>(min), T<sub>A</sub> = 25°C and not 100% tested.

**DATA RETENTION WAVEFORM ( $\overline{CS1}$  CONTROLLED)**

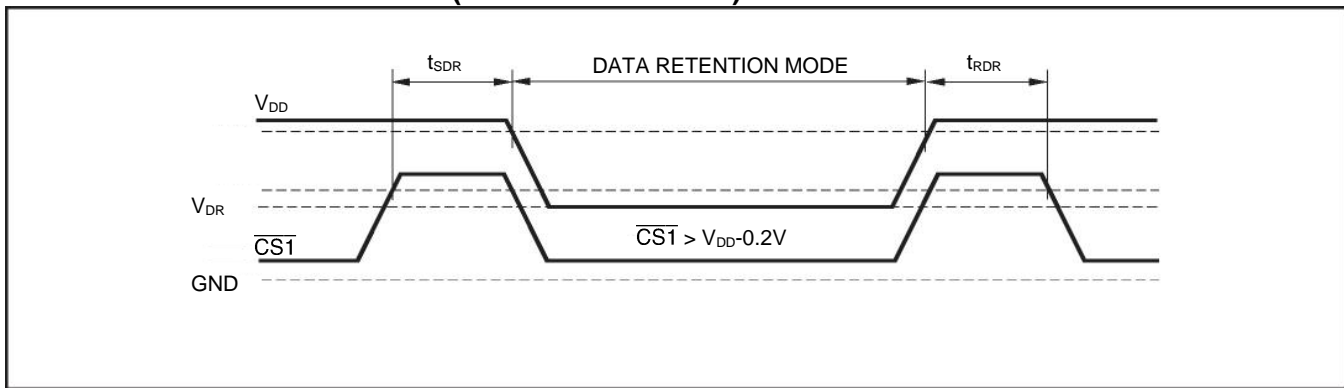

**DATA RETENTION WAVEFORM (CS2 CONTROLLED)**

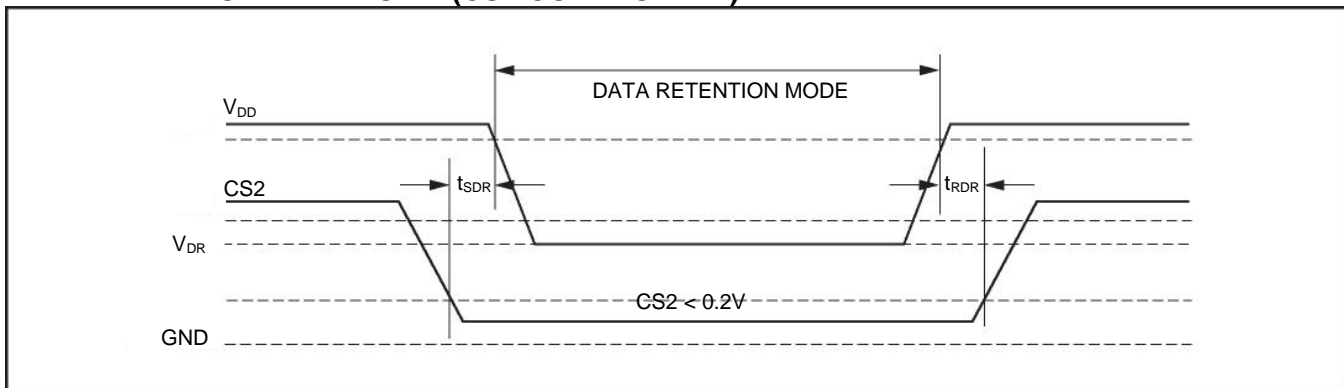

**ORDERING INFORMATION**  
**IS62WV10248EALL (1.65V - 2.2V)**

**Industrial Range: -40°C to +85°C**

Speed (ns)	Order Part No.	Package
55	IS62WV10248EALL-55TI	TSOP-II
	IS62WV10248EALL-55TLI	TSOP-II, Lead-free
	IS62WV10248EALL-55BI	mini BGA
	IS62WV10248EALL-55BLI	mini BGA, Lead-free

**IS62WV10248EBLL (2.2V - 3.6V)**

**Industrial Range: -40°C to +85°C**

Speed (ns)	Order Part No.	Package
45	IS62WV10248EBLL-45TI	TSOP-II
	IS62WV10248EBLL-45TLI	TSOP-II, Lead-free
	IS62WV10248EBLL-45BI	mini BGA
	IS62WV10248EBLL-45BLI	mini BGA, Lead-free
55	IS62WV10248EBLL-55TI	TSOP-II
	IS62WV10248EBLL-55TLI	TSOP-II, Lead-free
	IS62WV10248EBLL-55BI	mini BGA
	IS62WV10248EBLL-55BLI	mini BGA, Lead-free

**IS65WV10248EBLL (2.2V - 3.6V)**

**Automotive Range: -40°C to +125°C**

Speed (ns)	Order Part No.	Package
45	IS65WV10248EBLL-45CTLA3	TSOP-II, Lead-free, Copper Lead-frame

PACKAGE INFORMATION

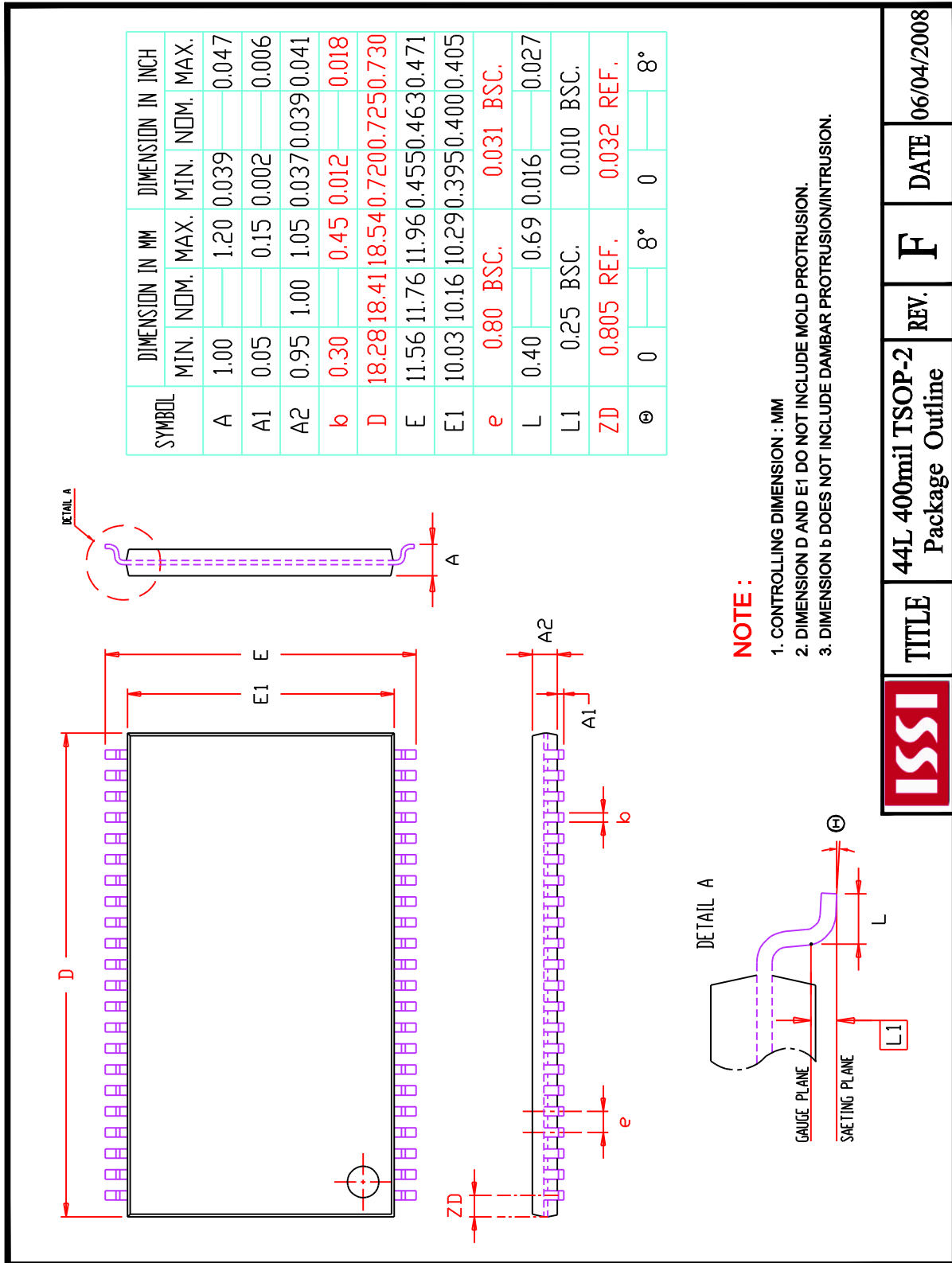

PACKAGE INFORMATION

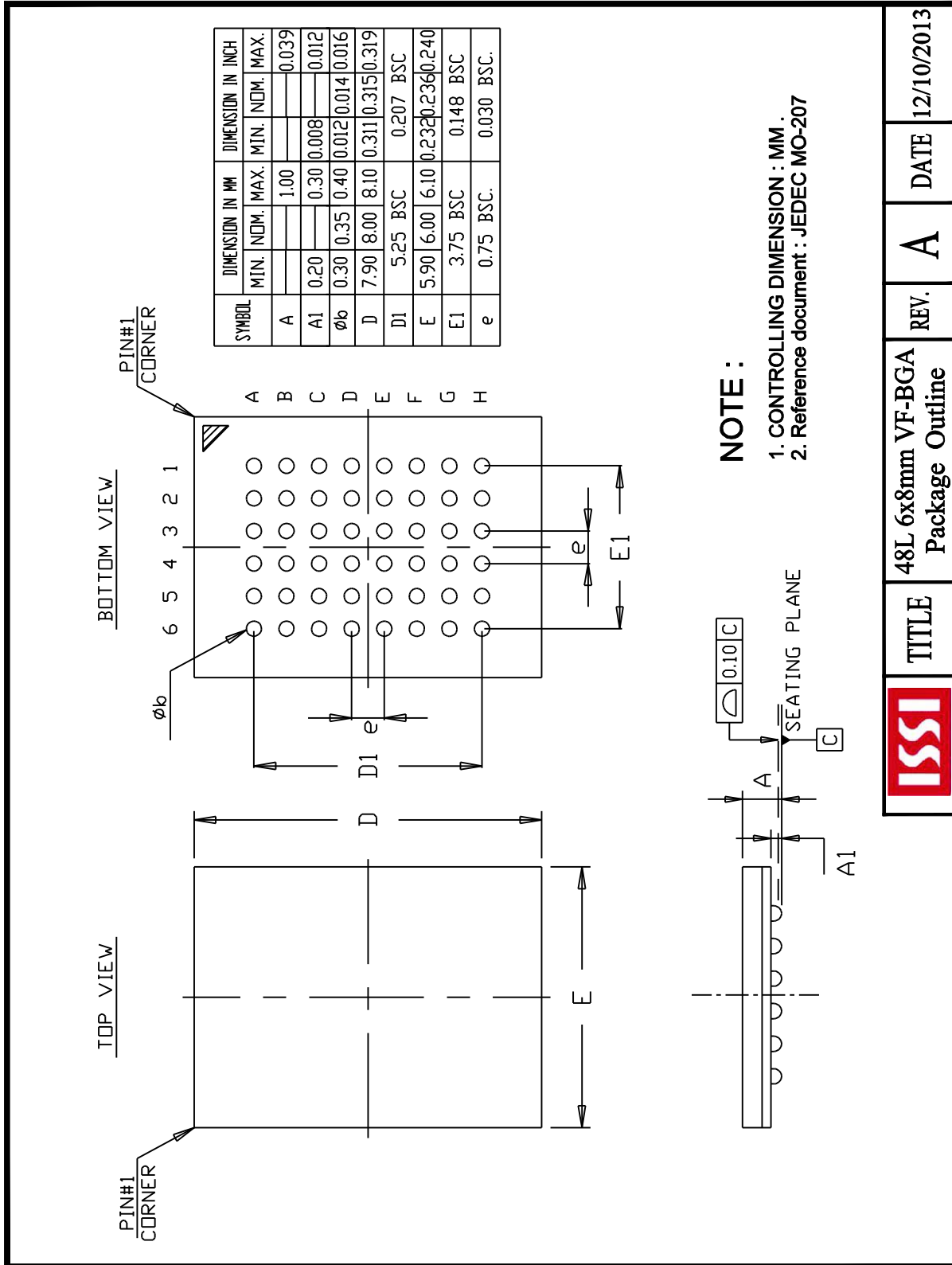

	TITLE	48L 6x8mm VF-BGA Package Outline	REV.	A	DATE	12/10/2013
--	-------	-------------------------------------	------	---	------	------------

Компания «Океан Электроники» предлагает заключение долгосрочных отношений при поставках импортных электронных компонентов на взаимовыгодных условиях!

Наши преимущества:

- Поставка оригинальных импортных электронных компонентов напрямую с производств Америки, Европы и Азии, а так же с крупнейших складов мира;
- Широкая линейка поставок активных и пассивных импортных электронных компонентов (более 30 млн. наименований);
- Поставка сложных, дефицитных, либо снятых с производства позиций;
- Оперативные сроки поставки под заказ (от 5 рабочих дней);
- Экспресс доставка в любую точку России;
- Помощь Конструкторского Отдела и консультации квалифицированных инженеров;
- Техническая поддержка проекта, помощь в подборе аналогов, поставка прототипов;
- Поставка электронных компонентов под контролем ВП;
- Система менеджмента качества сертифицирована по Международному стандарту ISO 9001;
- При необходимости вся продукция военного и аэрокосмического назначения проходит испытания и сертификацию в лаборатории (по согласованию с заказчиком);
- Поставка специализированных компонентов военного и аэрокосмического уровня качества (Xilinx, Altera, Analog Devices, Intersil, Interpoint, Microsemi, Actel, Aeroflex, Peregrine, VPT, Syfer, Eurofarad, Texas Instruments, MS Kennedy, Miteq, Cobham, E2V, MA-COM, Hittite, Mini-Circuits, General Dynamics и др.);

Компания «Океан Электроники» является официальным дистрибьютором и эксклюзивным представителем в России одного из крупнейших производителей разъемов военного и аэрокосмического назначения «JONHON», а так же официальным дистрибьютором и эксклюзивным представителем в России производителя высокотехнологичных и надежных решений для передачи СВЧ сигналов «FORSTAR».



## JONHON

«JONHON» (основан в 1970 г.)

Разъемы специального, военного и аэрокосмического назначения:

(Применяются в военной, авиационной, аэрокосмической, морской, железнодорожной, горно- и нефтедобывающей отраслях промышленности)

«FORSTAR» (основан в 1998 г.)

ВЧ соединители, коаксиальные кабели,  
кабельные сборки и микроволновые компоненты:

(Применяются в телекоммуникациях гражданского и специального назначения, в средствах связи, РЛС, а так же военной, авиационной и аэрокосмической отраслях промышленности).



Телефон: 8 (812) 309-75-97 (многоканальный)

Факс: 8 (812) 320-03-32

Электронная почта: [ocean@oceanchips.ru](mailto:ocean@oceanchips.ru)

Web: <http://oceanchips.ru/>

Адрес: 198099, г. Санкт-Петербург, ул. Калинина, д. 2, корп. 4, лит. А