

**Variable Transformers
Series 1500 • 9.5 to 15.0 Amperes**



1500 Series

The 1510/1520 Series Variable Transformers are highly reliable, dependable and accurate AC control devices. The 1510, 120 volt unit is rated at 15 amperes for constant current loads; while the 1520, 240 volt unit is rated at 9.5 amperes for constant current loads. Constant impedance ratings are listed in the specifications. They can be operated at frequencies between 50 and 2000 hertz with derating at higher than rated frequency.

Uncased models have the shaft extending from the base end. This shaft is fully adjustable and can be extended from either end for general utility mounting. Cased styles are available in either "C" style (featuring protective screening over the coil assembly

only) or the "CT" style (which also includes a terminal box cover with knock-outs to accept conduit).

Motor driven units are available in single, two and three ganged assemblies; cased or uncased styles as identified by the prefix "M" in the type number. If a motor driven model is ordered, be sure to prefix the part number with the desired travel time from 0 to maximum of 5, 15, 30, or 60 seconds.

The synchronous motor is designed for operation on 120 volts, 50/60 hertz single phase lines and draws approximately 0.3 amperes.

| PART NUMBER | | WIRING | INPUT | | OUTPUT | | | | SHAFT ROTATION FOR VOLTAGE INCREASE | TERMINAL CONNECTIONS (FOR INCREASING VOLTAGE) AS VIEWED FROM BASE END | | | SCHEMATIC (Pg 8 & 9) | NET WEIGHT LBS. MAX. | | |
|-------------------------------|-------------------------------------|------------------------|-------|-------|--------|-----------------------|---------|-------------------------|-------------------------------------|---|------------------------|--------|----------------------|----------------------|--------------|---------|
| MANUALLY OPERATED | MOTOR DRIVEN | | VOLTS | HERTZ | VOLTS | CONSTANT CURRENT LOAD | | CONSTANT IMPEDANCE LOAD | | INPUT | JUMPER* | OUTPUT | | MANUAL | MOTOR DRIVEN | |
| | | | | | | MAX AMPS | MAX KVA | MAX AMPS | | | | | | | | MAX KVA |
| 1510 1510C 1510CT | M1510+ M1510C+ M1510CT+ | Single Phase | 120 | 50/60 | 0-120 | 15 | 1.80 | 20 | 2.40 | CW | 2-4 | — | 4-3 | 14 | 15 3/4 | 26 |
| | | | | | | | | | CCW | 2-4 | — | 2-3 | | | | |
| | | | | | 0-140 | 15 | 2.10 | — | — | CW | 1-4 | — | 4-3 | | | |
| | | | | | | | | | CCW | 5-2 | — | 2-3 | | | | |
| 1510-2 1510C-2 1510CT-2 | M1510-2+ M1510C-2+ M1510CT-2+ | Single Phase Series | 240 | 50/60 | 0-240 | 15 | 3.60 | 20 | 4.80 | CW | 2-2 | 4-4 | 3-3 | 14 & 4 | 35 1/4 | 45 1/2 |
| | | | | | | | | | | CCW | 4-4 | 2-2 | 3-3 | | | |
| | | | | | 0-280 | 15 | 4.20 | — | — | CW | 1-1 | 4-4 | 3-3 | | | |
| | | | | | | | | | | CCW | 5-5 | 2-2 | 3-3 | | | |
| | | Three Phase Open Delta | 120++ | 50/60 | 0-120 | 15 | 3.12 | 20 | 4.15 | CW | 2-4-2 | 4-4 | 3-4-3 | 14 & 5 | | |
| | | | | | | | | | | CCW | 4-2-4 | 2-2 | 3-2-3 | | | |
| | | | | | 0-140 | 15 | 3.64 | — | — | CW | 1-4-1 | 4-4 | 3-4-3 | | | |
| | | | | | | | | | | CCW | 5-2-5 | 2-2 | 3-2-3 | | | |
| 1510-3 1510C-3 1510CT-3 | M1510-3+ M1510C-3+ M1510CT-3+ | Three Phase Wye | 240++ | 50/60 | 0-240 | 15 | 6.22 | 20 | 8.30 | CW | 2-2-2 | 4-4-4 | 3-3-3 | 14 & 6 | 55 1/2 | 65 3/4 |
| | | | | | | | | | CCW | 4-4-4 | 2-2-2 | 3-3-3 | | | | |
| | | | 60 | 0-280 | 15 | 7.26 | — | — | CW | 1-1-1 | 4-4-4 | 3-3-3 | | | | |
| | | | | | | | | CCW | 5-5-5 | 2-2-2 | 3-3-3 | | | | | |
| 3PN1510B | — | Single Phase | 120 | 50/60 | 0-140 | 15‡ | 2.10 | — | — | CW | LINE CORD & RECEPTACLE | | | 3 | 18 | — |
| 3PN1510BA 3PN1510BV | — | Single Phase | 120 | 50/60 | 0-140 | 15‡ | 2.10 | — | — | CW | LINE CORD & RECEPTACLE | | | 9 | 18 | — |
| 1520 1520C 1520CT | M1520+ M1520C+ M1520CT+ | Single Phase | 240 | 50/60 | 0-240 | 9.5 | 2.28 | 12 | 2.88 | CW | 2-4 | — | 4-3 | 15 | 19 1/4 | 29 1/2 |
| | | | | | | | | | | | CCW | 2-4 | — | | | |
| | | | 0-280 | 9.5 | 2.66 | — | — | CW | 1-4 | — | 4-3 | | | | | |
| | | | | | | | | CCW | 5-2 | — | 2-3 | | | | | |
| | | | 120 | 50/60 | 0-280 | 9.5# | 1.14§ | — | — | CW | 7-4 | — | 4-3 | | | |
| | | | | | | | | CCW | 6-2 | — | 2-3 | | | | | |
| 1520-2 1520C-2 1520CT-2 | M1520-2+ M1520C-2+ M1520CT-2+ | Single Phase Series | 480 | 50/60 | 0-480 | 9.5 | 4.56 | 12 | 5.76 | CW | 2-2 | 4-4 | 3-3 | 15 & 4 | 42 1/4 | 52 1/2 |
| | | | | | | | | | | | CCW | 4-4 | 2-2 | | | |
| | | | 0-560 | 9.5 | 5.32 | — | — | CW | 1-1 | 4-4 | 3-3 | | | | | |
| | | | | | | | | CCW | 5-5 | 2-2 | 3-3 | | | | | |
| | | | 240 | 50/60 | 0-560 | 9.5# | 2.28§ | — | — | CW | 7-7 | 4-4 | 3-3 | | | |
| | | | | | | | | CCW | 6-6 | 2-2 | 3-3 | | | | | |
| | | Three Phase Open Delta | 240++ | 50/60 | 0-240 | 9.5 | 3.95 | 12 | 5.0 | CW | 2-4-2 | 4-4 | 3-4-3 | 15 & 5 | | |
| | | | | | | | | | | CCW | 4-2-4 | 2-2 | 3-2-3 | | | |
| | | | 0-280 | 9.5 | 4.61 | — | — | CW | 1-4-1 | 4-4 | 3-4-3 | | | | | |
| | | | | | | | | CCW | 5-2-5 | 2-2 | 3-2-3 | | | | | |
| | | | 120++ | 50/60 | 0-280 | 9.5# | 1.98§ | — | — | CW | 7-4-7 | 4-4 | 3-4-3 | | | |
| | | | | | | | | CCW | 6-2-6 | 2-2 | 3-2-3 | | | | | |
| 1520-3 1520C-3 1520CT-3 | M1520-3+ M1520C-3+ M1520CT-3+ | Three Phase Wye | 480++ | 50/60 | 0-480 | 9.5 | 7.90 | 12 | 10 | CW | 2-2-2 | 4-4-4 | 3-3-3 | 15 & 6 | 66 | 76 1/4 |
| | | | | | | | | | | CCW | 4-4-4 | 2-2-2 | 3-3-3 | | | |
| | | | 60 | 0-560 | 9.5 | 9.21 | — | — | CW | 1-1-1 | 4-4-4 | 3-3-3 | | | | |
| | | | | | | | | CCW | 5-5-5 | 2-2-2 | 3-3-3 | | | | | |
| | | | 240++ | 60 | 0-560 | 9.5# | 3.96§ | — | — | CW | 7-7-7 | 4-4-4 | 3-3-3 | | | |
| | | | | | | | | CCW | 6-6-6 | 2-2-2 | 3-3-3 | | | | | |
| 3PN1520B | — | Single Phase | 240 | 50/60 | 0-280 | 9.5‡ | 2.66 | — | — | CW | LINE CORD & RECEPTACLE | | | 3 | 22 | — |

"A" suffix includes Ammeter, "V" suffix includes Voltmeter

+ Motor driven units use terminal connections for CCW increasing voltage, as viewed from the base end. See Fig 23 on page 9 for motor wiring.

• Jumper provided in the standard common position and should be moved or removed as required.

++ Line to line voltage

‡ Unit is fused for the constant current rating at the factory.

§ Maximum KVA at maximum output voltage and corresponding derated output current. Maximum KVA for lower voltages may be calculated from derating curve Figure B, page 6.

If ganged units are used in a system that ordinarily has a common neutral or ground between source and load, the neutral or ground must be connected to the common terminals of the variable transformer assembly. If the system has no neutral, the load must be balanced or the transformers will be damaged.

Maximum output current in output voltage range from 0 to 25% above line voltage. At higher output voltages, the output current must be reduced according to the derating curve, Figure B, page 6.

1500 Series

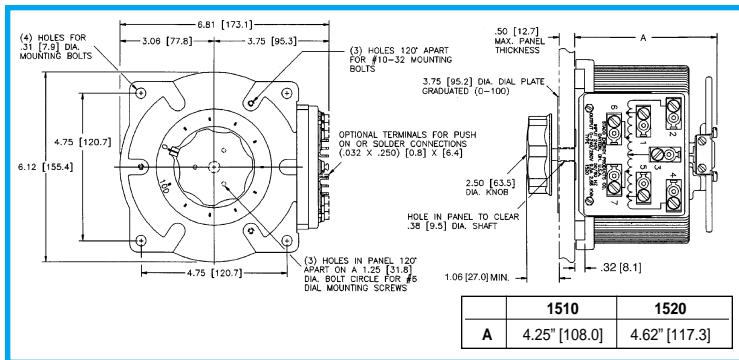

Manual Single, Uncased

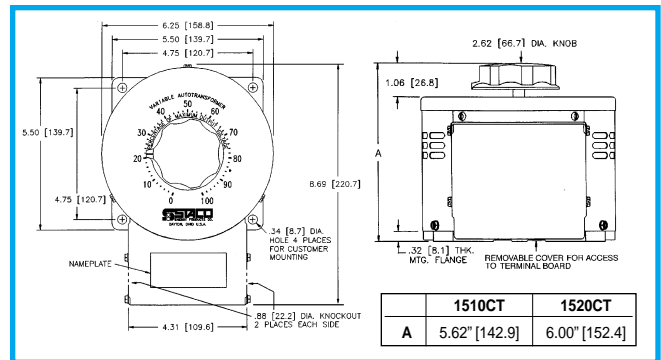

Manual Single, Cased

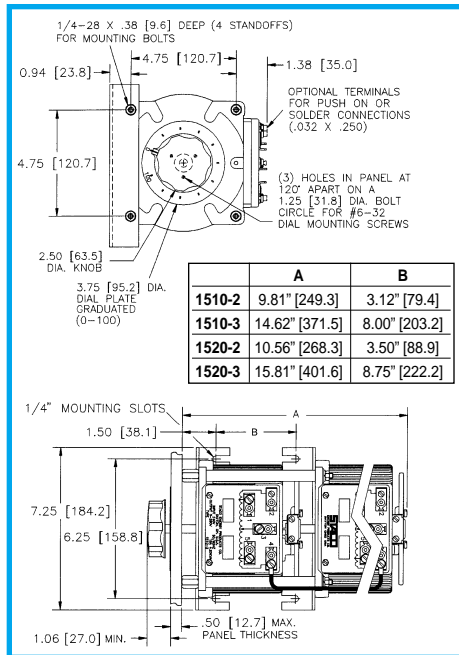

Manual Two- and Three-Ganged, Uncased

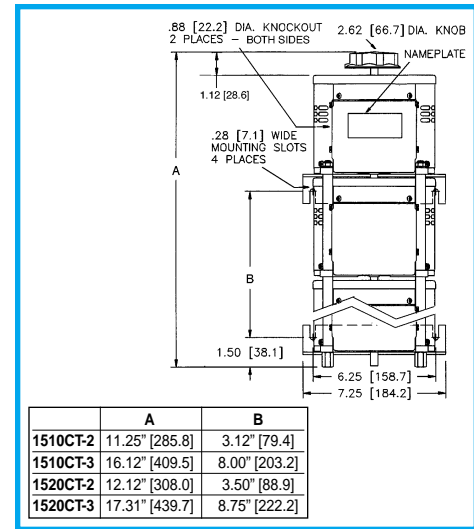

Manual Two- and Three-Ganged, Cased

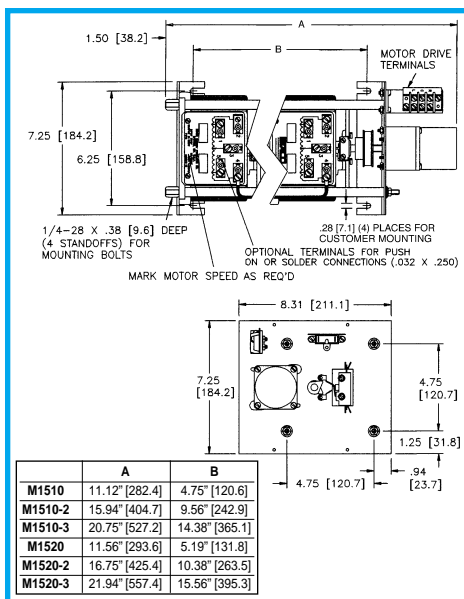

Motor-Driven Single, Two and Three-Ganged, Uncased

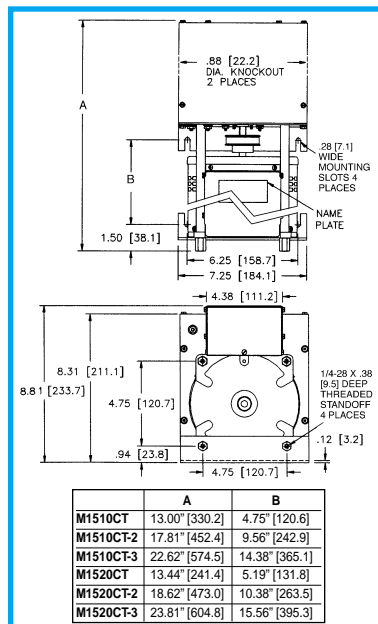

Motor-Driven Single, Two and Three-Ganged, Cased

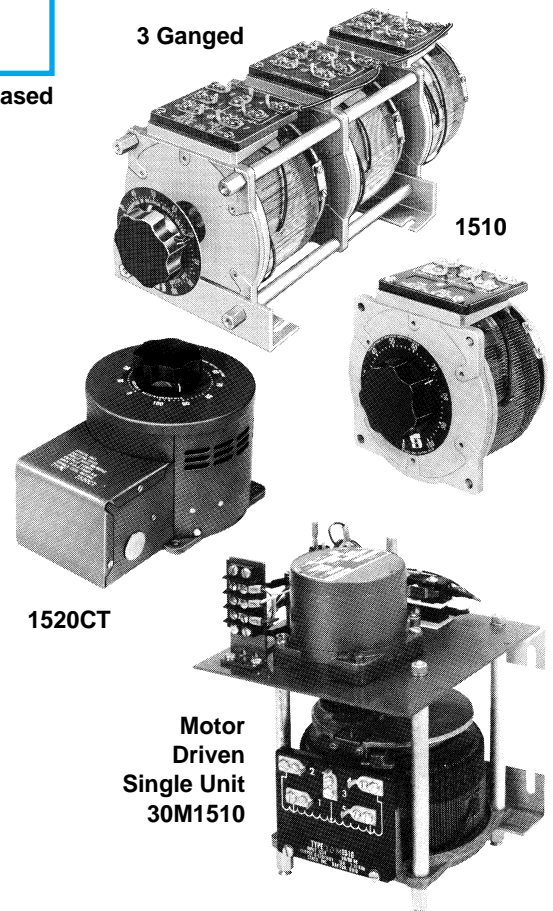

Компания «Океан Электроники» предлагает заключение долгосрочных отношений при поставках импортных электронных компонентов на взаимовыгодных условиях!

Наши преимущества:

- Поставка оригинальных импортных электронных компонентов напрямую с производств Америки, Европы и Азии, а так же с крупнейших складов мира;
- Широкая линейка поставок активных и пассивных импортных электронных компонентов (более 30 млн. наименований);
- Поставка сложных, дефицитных, либо снятых с производства позиций;
- Оперативные сроки поставки под заказ (от 5 рабочих дней);
- Экспресс доставка в любую точку России;
- Помощь Конструкторского Отдела и консультации квалифицированных инженеров;
- Техническая поддержка проекта, помощь в подборе аналогов, поставка прототипов;
- Поставка электронных компонентов под контролем ВП;
- Система менеджмента качества сертифицирована по Международному стандарту ISO 9001;
- При необходимости вся продукция военного и аэрокосмического назначения проходит испытания и сертификацию в лаборатории (по согласованию с заказчиком);
- Поставка специализированных компонентов военного и аэрокосмического уровня качества (Xilinx, Altera, Analog Devices, Intersil, Interpoint, Microsemi, Actel, Aeroflex, Peregrine, VPT, Syfer, Eurofarad, Texas Instruments, MS Kennedy, Miteq, Cobham, E2V, MA-COM, Hittite, Mini-Circuits, General Dynamics и др.);

Компания «Океан Электроники» является официальным дистрибьютором и эксклюзивным представителем в России одного из крупнейших производителей разъемов военного и аэрокосмического назначения «JONHON», а так же официальным дистрибьютором и эксклюзивным представителем в России производителя высокотехнологичных и надежных решений для передачи СВЧ сигналов «FORSTAR».



JONHON

«JONHON» (основан в 1970 г.)

Разъемы специального, военного и аэрокосмического назначения:

(Применяются в военной, авиационной, аэрокосмической, морской, железнодорожной, горно- и нефтедобывающей отраслях промышленности)

«FORSTAR» (основан в 1998 г.)

ВЧ соединители, коаксиальные кабели, кабельные сборки и микроволновые компоненты:

(Применяются в телекоммуникациях гражданского и специального назначения, в средствах связи, РЛС, а так же военной, авиационной и аэрокосмической отраслях промышленности).



Телефон: 8 (812) 309-75-97 (многоканальный)

Факс: 8 (812) 320-03-32

Электронная почта: ocean@oceanchips.ru

Web: <http://oceanchips.ru/>

Адрес: 198099, г. Санкт-Петербург, ул. Калинина, д. 2, корп. 4, лит. А