

# CM1214A

## 1 and 2-Channel PicoGuard<sup>®</sup> AC Signal ESD Protector

### Product Description

The CM1214A *PicoGuard*<sup>®</sup> ESD protector is used to protect bipolar signal lines against electrostatic discharge (ESD). The CM1214A allows operation in high-speed environments with signals levels up to  $\pm 5$  V.

The CM1214A comes in two versions:

- The CM1214A-01SO is a single channel ESD protector and is available in a 3-lead SOT23-3 package.
- The CM1214A-02MR is a dual channel ESD protector and is available in an 8-lead MSOP-8 package.

The low sub-1 pF loading capacitance makes the CM1214A-01SO ideal for protecting high-speed interfaces including RF switches and amplifiers.

The CM1214A-02MR is ideal for dual high-speed signal pairs used in Gigabit Ethernet, ADSL, etc. The CM1214A-02MR can also be used for higher transmit voltage applications by connecting the two channels in series.

### Features

- Single Channel ESD Protection for an AC Signal Up To  $\pm 5$  V for 0.25 W Transmit Power
- Connects Two Channels in Series for Signals Up To  $\pm 10$  V (1 W transmit power)
- $\pm 8$  kV ESD Protection Per IEC 61000-4-2 Contact Discharge
- Sub-1pF Loading Capacitance
- Minimal Variation with Voltage and Temperature
- Each I/O Pin Can Withstand Over 1000 ESD Strikes\*
- SOT23-3 and MSOP-8 Packages
- These Devices are Pb-Free and are RoHS Compliant

### Applications

- RF Switch and Amplifier Protection
- RF Modules and RF IC Protection
- Wireless Handsets and WLAN
- High-Speed AC Signals for Gbit Ethernet, etc.



**ON Semiconductor<sup>®</sup>**

<http://onsemi.com>

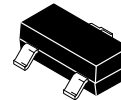

**SOT23-3  
SO SUFFIX  
CASE 318**

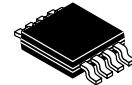

**MSOP-8  
MR SUFFIX  
CASE 846AD**

### BLOCK DIAGRAM



CM1214A-01SO

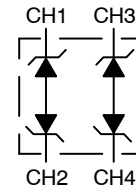

CM1214A-02MR

### MARKING DIAGRAM

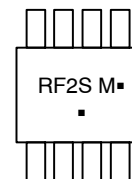
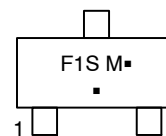

XXX = Specific Device Code  
M = Date Code  
▪ = Pb-Free Package  
(Note: Microdot may be in either location)

### ORDERING INFORMATION

Device	Package	Shipping <sup>†</sup>
CM1214A-01SO	SOT23 (Pb-Free)	3000/Tape & Reel
CM1214A-02MR	MSOP (Pb-Free)	4000/Tape & Reel

<sup>†</sup>For information on tape and reel specifications, including part orientation and tape sizes, please refer to our Tape and Reel Packaging Specification Brochure, BRD8011/D.

\*Standard test condition is IEC61000-4-2 level 4 test circuit with each pin subjected to  $\pm 8$  kV contact discharge for 1000 pulses. Discharges are timed at 1 second intervals and all 1000 strikes are completed in one continuous test run. The part is then subjected to standard production test to verify that all of the tested parameters are within spec after the 1000 strikes.

# CM1214A

**Table 1. PIN DESCRIPTIONS**

SOT23-3 Package		
Pin	Name	Description
1	CH1	ESD Channel
2	CH2	ESD Channel
3	N.C.	No connect

MSOP-8 Package		
Pin	Name	Description
1	CH1	ESD Channel
2	N.C.	No connect
3	N.C.	No connect
4	CH3	ESD Channel
5	N.C.	No connect
6	CH4	ESD Channel
7	CH2	ESD Channel
8	N.C.	No connect

**PACKAGE / PINOUT DIAGRAMS**

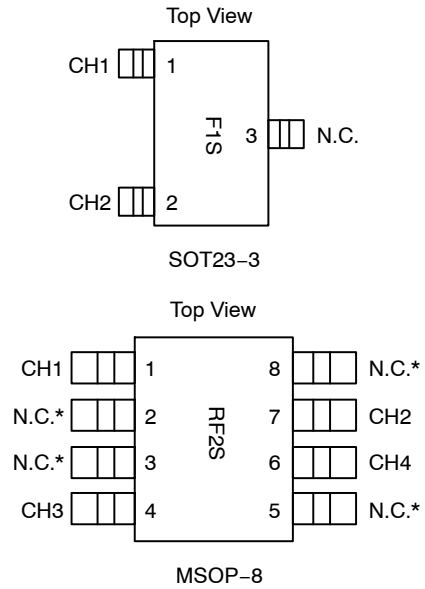

\* All N.C. pins must be left floating (i.e., not connected to the PCB). See applications section for more information.

## SPECIFICATIONS

**Table 2. ABSOLUTE MAXIMUM RATINGS**

Parameter	Rating	Units
DC Voltage between CH pins	7	V
Operating Temperature Range	-40 to +85	°C
Storage Temperature Range	-65 to +150	°C
Package Power Rating SOT23-3 Package (CM1214A-01SO) MSOP8 Package (CM1214A-02MR)	225 400	mW

Stresses exceeding Maximum Ratings may damage the device. Maximum Ratings are stress ratings only. Functional operation above the Recommended Operating Conditions is not implied. Extended exposure to stresses above the Recommended Operating Conditions may affect device reliability.

**Table 3. STANDARD OPERATING CONDITIONS**

Parameter	Rating	Units
Operating Temperature Range	-40 to +85	°C

**Table 4. ELECTRICAL OPERATING CHARACTERISTICS (Note 1)**

Symbol	Parameter	Conditions	Min	Typ	Max	Units
V <sub>ST</sub>	Standoff Voltage	I = 10 μA		±7		V
V <sub>ESD</sub>	ESD Voltage Protection Peak discharge voltage between CH pins a) Contact discharge per IEC 61000-4-2 standard	(Notes 2 and 3)	±8			kV
I <sub>LEAK</sub>	Channel Leakage Current	T <sub>A</sub> = 25°C, 5.5 V between CH pins		±0.1	±1.0	μA
R <sub>DYN</sub>	Dynamic Resistance	T <sub>A</sub> = 25°C, I <sub>PP</sub> = 1 A, t <sub>P</sub> = 8/20 μS Any I/O pin to Ground (Note 4)		1.36		Ω

# CM1214A

**Table 4. ELECTRICAL OPERATING CHARACTERISTICS** (Note 1)

Symbol	Parameter	Conditions	Min	Typ	Max	Units
V <sub>CL</sub>	Channel Clamp Voltage	T <sub>A</sub> = 25°C, I <sub>PP</sub> = 1 A, t <sub>P</sub> = 8/20 μS (Note 4)		11.3		V
C <sub>IN</sub>	Channel Input Capacitance Voltage between CH pins = 0 V Voltage between CH pins = 5 V	Measured at 1 MHz between CH pins	0.4 0.35	0.6 0.54	0.9 0.8	pF

1. All parameters specified at T<sub>A</sub> = -40°C to +85°C unless otherwise noted.
2. Standard IEC 61000-4-2 with C<sub>Discharge</sub> = 150 pF, R<sub>Discharge</sub> = 330 Ω.
3. From CH pin with other CH pin grounded.
4. No Connect pins are left open for all tests.

## PERFORMANCE INFORMATION

### Typical Capacitance Characteristics vs. Voltage

CM1214A illustrates how the loading capacitance remains mainly flat across the voltage range from 0 V to 5 V, the voltage between CH pins.

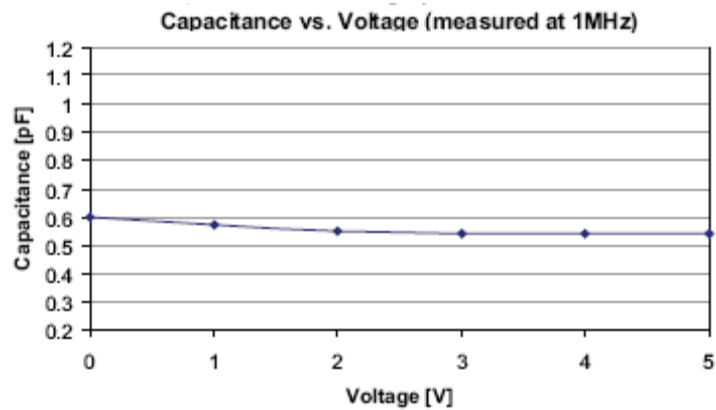

**Figure 1. CM1214A Capacitance vs. Voltage**

### Typical Voltage Current (VI) Characteristics (low current)

CM1214A shows how the CM1214A experiences a symmetrical I/V curve, without any snapback or trigger voltage. It gradually starts to turn on at about 6 V and clamps above 7 V.

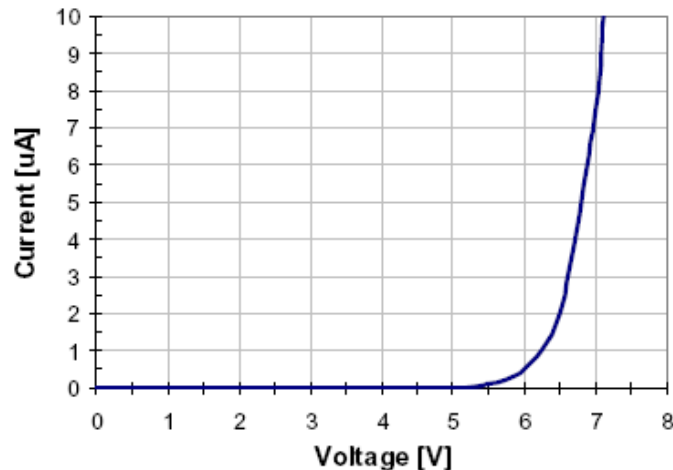

**Figure 2. CM1214A VI Characteristics, Low Current**

# CM1214A

## PERFORMANCE INFORMATION (Cont'd)

### Typical Voltage–Current (VI) Characteristics (high current, pulse condition)

CM1214A shows how the CM1214A experiences a symmetrical I/V curve, without any snapback or trigger voltage. The curve shows only one polarity.

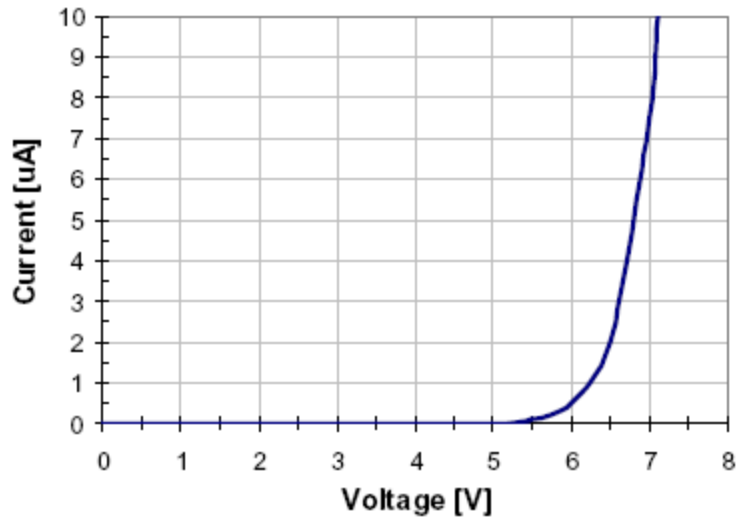

Figure 3. CM1214A VI Characteristics, High Current, Pulse (clamping) Condition

### Typical Capacitance Characteristics vs. Temperature

CM1214A illustrates the loading capacitance for both 0 VDC and 1.65 VDC input across the  $-40$  to  $85^{\circ}\text{C}$  temperature range.

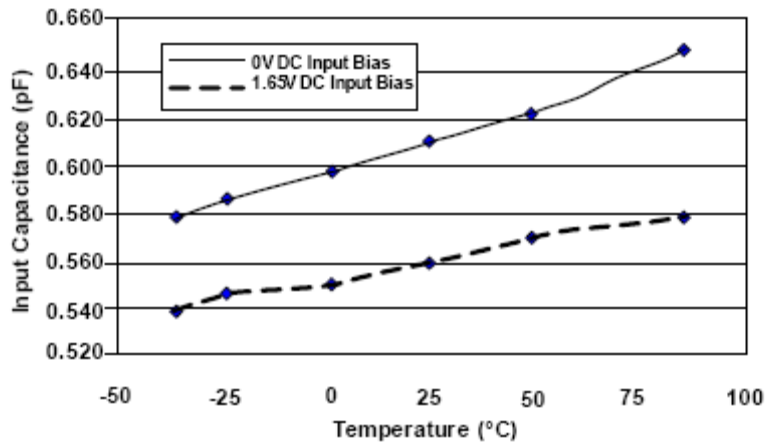

Figure 4. CM1214A Capacitance vs. Temperature

# CM1214A

## PERFORMANCE INFORMATION (Cont'd)

Typical Filter Performance (nominal conditions unless specified otherwise, 50 Ohm Environment)

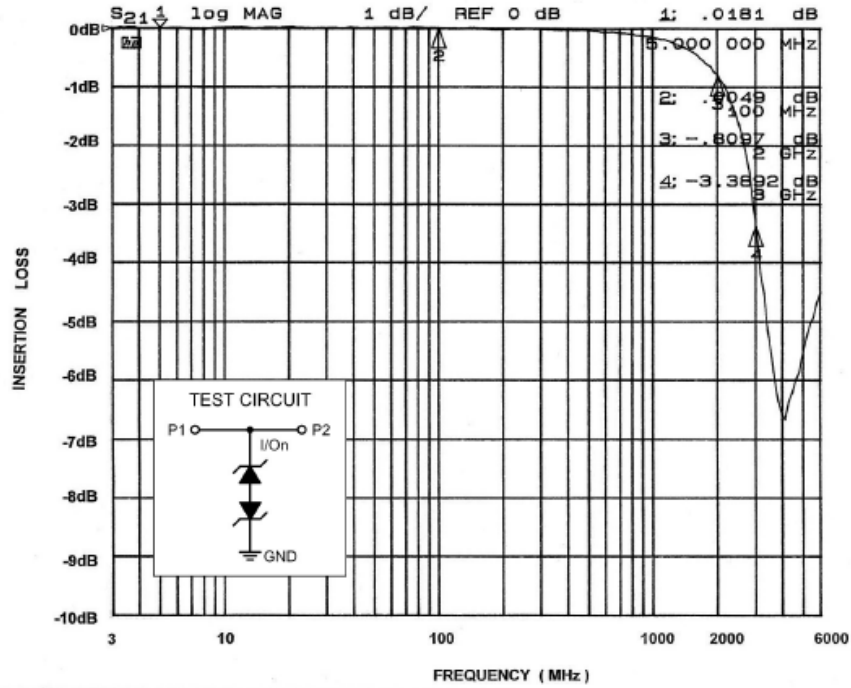

Figure 5. Insertion Loss vs. Frequency (0 V DC Bias)

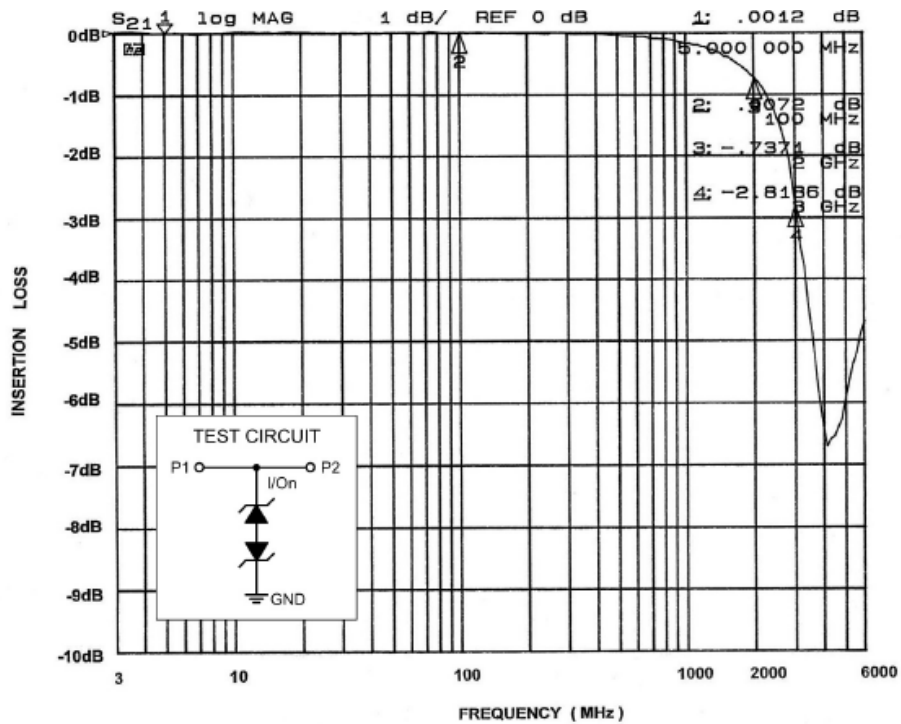

Figure 6. Insertion Loss vs. Frequency (2.5 V DC Bias)

# CM1214A

## APPLICATION INFORMATION

### CM1214A-01SO

The CM1214A-01SO protects a single bipolar signal line often found in RF circuits. One I/O pin (pin 1 for example) is connected to the signal line for protection, and the other I/O pin is tied to GND. It is important to have a solid ground connection to reduce the clamping voltage. *Pin 3 of the 3-lead SOT23 must be left open (and not connected on the PCB).*

### CM1214A-02MR

The CM1214A-02MR protects two bipolar lines, such as for Gbit Ethernet. The PCB traces underneath the package connect across to the corresponding pins (Pins 1, 4, 6 and 7). *Pins 2, 3, 5 and 8 of the MSOP-8 package must be left open (and not connected on the PCB).*

Any disturbance on the line above or below the standoff voltage is clamped.

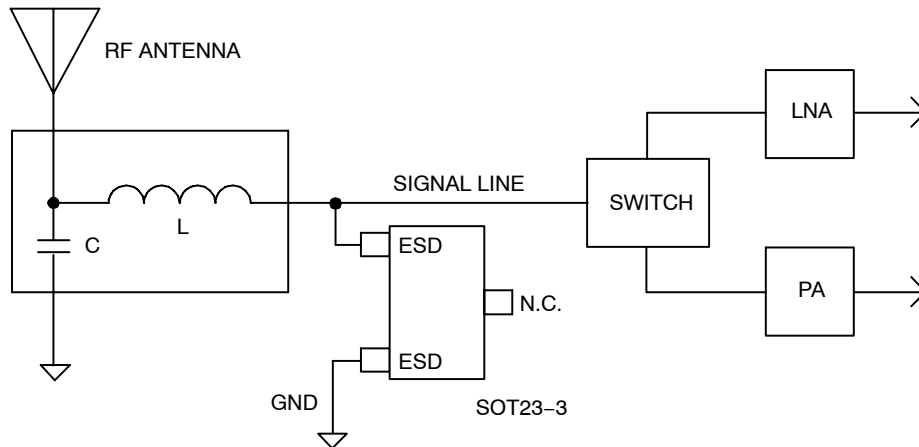

Figure 7. Typical Application - RF Switch and Amplifier Protection, CM1214A-01SO in 3-lead SOT23

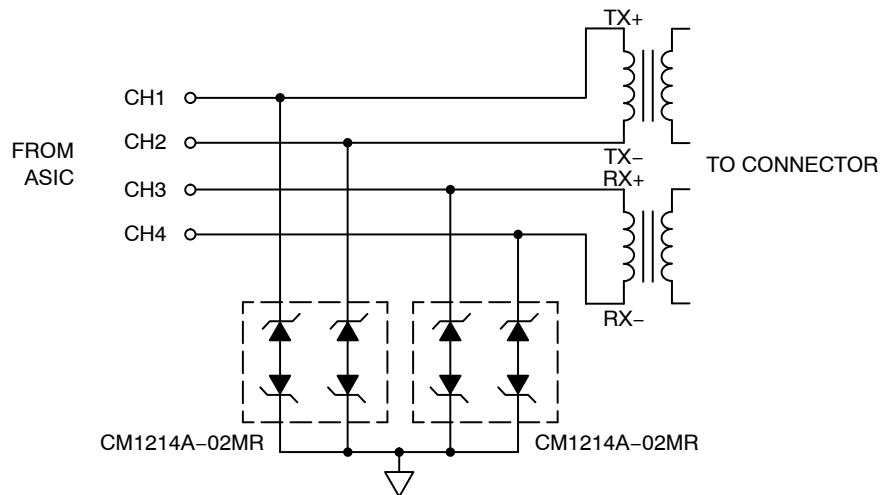
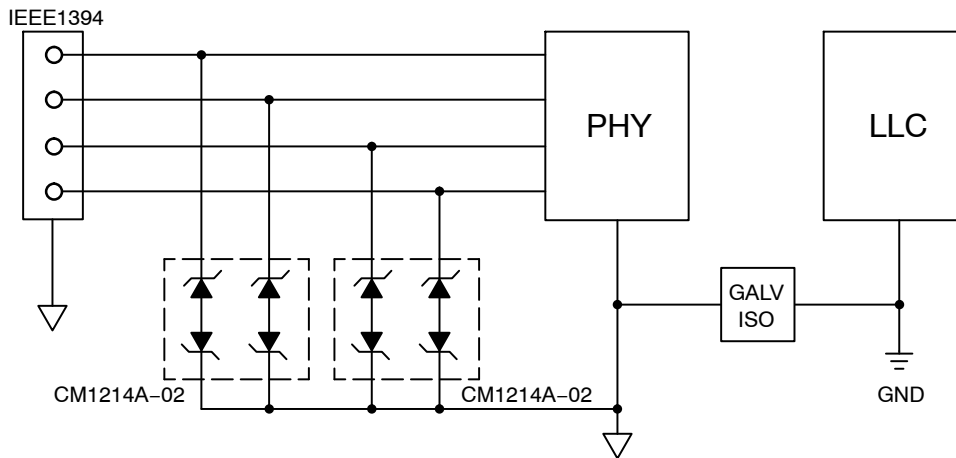

Figure 8. Typical Application - Ethernet Protection, CM1214A-02MR in 8-lead MSOP

# CM1214A

## APPLICATION INFORMATION (Cont'd)



Keep the ESD devices on the PHY side of the galvanic isolation and inside the  $V_{CC}$  domain of the PHY controller

**Figure 9. Typical Application – IEEE1394 Protection, CM1214A-02MR in 8-lead MSOP**

# CM1214A

## PACKAGE DIMENSIONS

SOT-23 (TO-236)  
CASE 318-08  
ISSUE AP

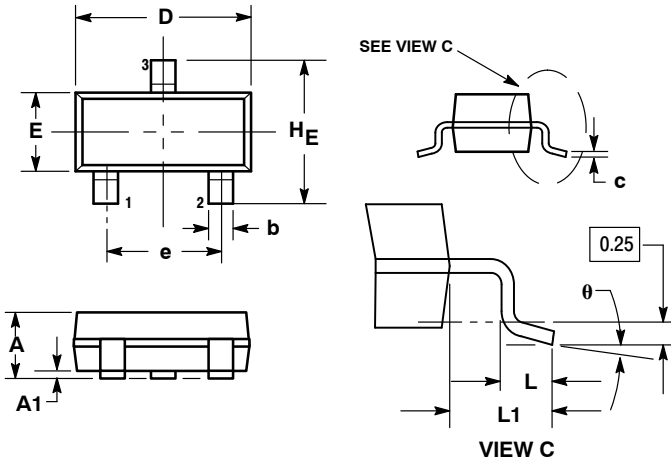

NOTES:

1. DIMENSIONING AND TOLERANCING PER ANSI Y14.5M, 1982.
2. CONTROLLING DIMENSION: INCH.
3. MAXIMUM LEAD THICKNESS INCLUDES LEAD FINISH THICKNESS. MINIMUM LEAD THICKNESS IS THE MINIMUM THICKNESS OF BASE MATERIAL.
4. DIMENSIONS D AND E DO NOT INCLUDE MOLD FLASH, PROTRUSIONS, OR GATE BURRS.

DIM	MILLIMETERS			INCHES		
	MIN	NOM	MAX	MIN	NOM	MAX
A	0.89	1.00	1.11	0.035	0.040	0.044
A1	0.01	0.06	0.10	0.001	0.002	0.004
b	0.37	0.44	0.50	0.015	0.018	0.020
c	0.09	0.13	0.18	0.003	0.005	0.007
D	2.80	2.90	3.04	0.110	0.114	0.120
E	1.20	1.30	1.40	0.047	0.051	0.055
e	1.78	1.90	2.04	0.070	0.075	0.081
L	0.10	0.20	0.30	0.004	0.008	0.012
L1	0.35	0.54	0.69	0.014	0.021	0.029
HE	2.10	2.40	2.64	0.083	0.094	0.104
θ	0°	---	10°	0°	---	10°

### SOLDERING FOOTPRINT

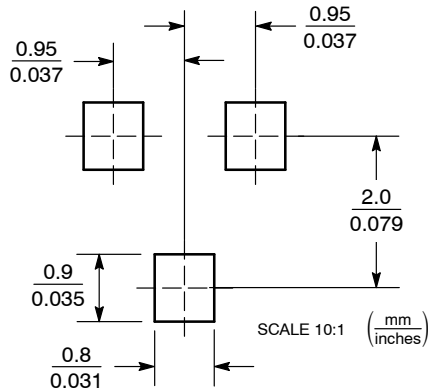



# CM1214A

## PACKAGE DIMENSIONS

MSOP 8, 3x3  
CASE 846AD-01  
ISSUE O

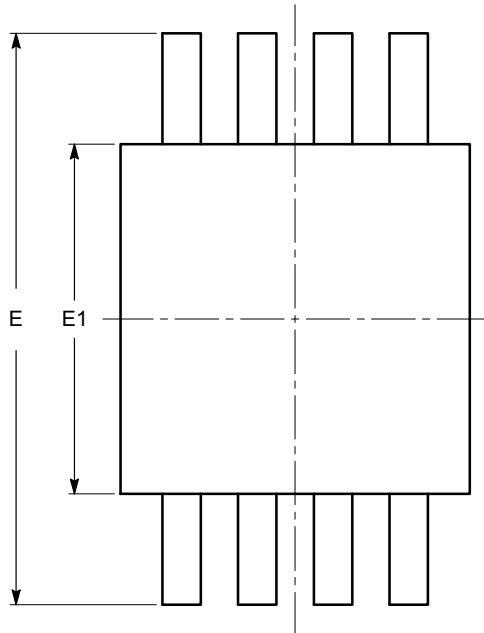

TOP VIEW

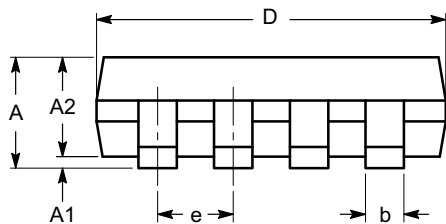

SIDE VIEW

SYMBOL	MIN	NOM	MAX
A			1.10
A1	0.05	0.10	0.15
A2	0.75	0.85	0.95
b	0.22		0.38
c	0.13		0.23
D	2.90	3.00	3.10
E	4.80	4.90	5.00
E1	2.90	3.00	3.10
e	0.65 BSC		
L	0.40	0.60	0.80
L1	0.95 REF		
L2	0.25 BSC		
$\theta$	0°		6°

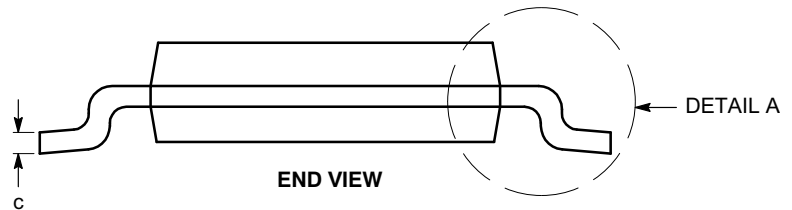

END VIEW

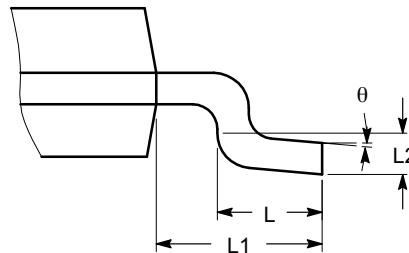

DETAIL A

**Notes:**

- (1) All dimensions are in millimeters. Angles in degrees.
- (2) Complies with JEDEC MO-187.

PicoGuard is a registered trademark of Semiconductor Components Industries, LLC (SCILLC).

**ON Semiconductor** and  are registered trademarks of Semiconductor Components Industries, LLC (SCILLC). SCILLC reserves the right to make changes without further notice to any products herein. SCILLC makes no warranty, representation or guarantee regarding the suitability of its products for any particular purpose, nor does SCILLC assume any liability arising out of the application or use of any product or circuit, and specifically disclaims any and all liability, including without limitation special, consequential or incidental damages. "Typical" parameters which may be provided in SCILLC data sheets and/or specifications can and do vary in different applications and actual performance may vary over time. All operating parameters, including "Typicals" must be validated for each customer application by customer's technical experts. SCILLC does not convey any license under its patent rights nor the rights of others. SCILLC products are not designed, intended, or authorized for use as components in systems intended for surgical implant into the body, or other applications intended to support or sustain life, or for any other application in which the failure of the SCILLC product could create a situation where personal injury or death may occur. Should Buyer purchase or use SCILLC products for any such unintended or unauthorized application, Buyer shall indemnify and hold SCILLC and its officers, employees, subsidiaries, affiliates, and distributors harmless against all claims, costs, damages, and expenses, and reasonable attorney fees arising out of, directly or indirectly, any claim of personal injury or death associated with such unintended or unauthorized use, even if such claim alleges that SCILLC was negligent regarding the design or manufacture of the part. SCILLC is an Equal Opportunity/Affirmative Action Employer. This literature is subject to all applicable copyright laws and is not for resale in any manner.

**PUBLICATION ORDERING INFORMATION**

**LITERATURE FULFILLMENT:**  
Literature Distribution Center for ON Semiconductor  
P.O. Box 5163, Denver, Colorado 80217 USA  
**Phone:** 303-675-2175 or 800-344-3860 Toll Free USA/Canada  
**Fax:** 303-675-2176 or 800-344-3867 Toll Free USA/Canada  
**Email:** orderlit@onsemi.com

**N. American Technical Support:** 800-282-9855 Toll Free USA/Canada  
**Europe, Middle East and Africa Technical Support:**  
Phone: 421 33 790 2910  
**Japan Customer Focus Center**  
Phone: 81-3-5817-1050

**ON Semiconductor Website:** [www.onsemi.com](http://www.onsemi.com)  
**Order Literature:** <http://www.onsemi.com/orderlit>  
For additional information, please contact your local Sales Representative

Компания «Океан Электроники» предлагает заключение долгосрочных отношений при поставках импортных электронных компонентов на взаимовыгодных условиях!

Наши преимущества:

- Поставка оригинальных импортных электронных компонентов напрямую с производств Америки, Европы и Азии, а так же с крупнейших складов мира;
- Широкая линейка поставок активных и пассивных импортных электронных компонентов (более 30 млн. наименований);
- Поставка сложных, дефицитных, либо снятых с производства позиций;
- Оперативные сроки поставки под заказ (от 5 рабочих дней);
- Экспресс доставка в любую точку России;
- Помощь Конструкторского Отдела и консультации квалифицированных инженеров;
- Техническая поддержка проекта, помощь в подборе аналогов, поставка прототипов;
- Поставка электронных компонентов под контролем ВП;
- Система менеджмента качества сертифицирована по Международному стандарту ISO 9001;
- При необходимости вся продукция военного и аэрокосмического назначения проходит испытания и сертификацию в лаборатории (по согласованию с заказчиком);
- Поставка специализированных компонентов военного и аэрокосмического уровня качества (Xilinx, Altera, Analog Devices, Intersil, Interpoint, Microsemi, Actel, Aeroflex, Peregrine, VPT, Syfer, Eurofarad, Texas Instruments, MS Kennedy, Miteq, Cobham, E2V, MA-COM, Hittite, Mini-Circuits, General Dynamics и др.);

Компания «Океан Электроники» является официальным дистрибьютором и эксклюзивным представителем в России одного из крупнейших производителей разъемов военного и аэрокосмического назначения «JONHON», а так же официальным дистрибьютором и эксклюзивным представителем в России производителя высокотехнологичных и надежных решений для передачи СВЧ сигналов «FORSTAR».



## JONHON

«JONHON» (основан в 1970 г.)

Разъемы специального, военного и аэрокосмического назначения:

(Применяются в военной, авиационной, аэрокосмической, морской, железнодорожной, горно- и нефтедобывающей отраслях промышленности)

«FORSTAR» (основан в 1998 г.)

ВЧ соединители, коаксиальные кабели, кабельные сборки и микроволновые компоненты:

(Применяются в телекоммуникациях гражданского и специального назначения, в средствах связи, РЛС, а так же военной, авиационной и аэрокосмической отраслях промышленности).



Телефон: 8 (812) 309-75-97 (многоканальный)

Факс: 8 (812) 320-03-32

Электронная почта: [ocean@oceanchips.ru](mailto:ocean@oceanchips.ru)

Web: <http://oceanchips.ru/>

Адрес: 198099, г. Санкт-Петербург, ул. Калинина, д. 2, корп. 4, лит. А