USB-to-GPIO Bridging with Microchip USB70xx Hubs

*Authors: Josh Averyt and Andrew Rogers
Microchip Technology Inc.*

INTRODUCTION

The USB-to-GPIO bridging feature of Microchip's USB70xx family of hubs provides system designers expanded system control and potential BOM reductions. General Purpose Input/Outputs (GPIOs) may be used for any general 3.3V-level digital control and input functions.

Commands may be sent from the USB Host to the internal Hub Feature Controller (HFC) device in the Microchip hub to perform the following functions:

- Set the direction of the GPIO (input or output)
- Enable a pull-up resistor
- Enable a pull-down resistor
- Read the state
- Set the state

SECTIONS

[General Information](#)

[Part Number-Specific Information](#)

[SDK Implementation](#)

[Manual Implementation](#)

[Examples](#)

REFERENCES

Consult the following documents for details on the specific parts referred to in this application note:

- *Microchip USB7002 Data Sheet*
- *Microchip USB7050 Data Sheet*
- *Microchip USB7051 Data Sheet*
- *Microchip USB7052 Data Sheet*
- *Microchip USB7056 Data Sheet*
- *Microchip Configuration Options for the USB70xx*

AN2750

GENERAL INFORMATION

Microchip hub USB Bridging features work via host commands sent to an embedded Hub Feature Controller within the device located on an additional internal USB port. In order for the bridging features to work correctly, this internal Hub Feature Controller must be enabled by default. [Table 1](#) provides details on default Hub Feature Controller settings per device.

TABLE 1: DEFAULT SETTINGS FOR HUB FEATURE CONTROLLER ENABLE

Part Number	Part Summary	Hub Feature Controller Default Setting
USB7002	4-Port USB3.1 Gen1 Hub	Enabled by default on port 6
USB7050	4-Port USB3.1 Gen1 Hub with USB power delivery on 3 ports	Enabled by default on port 6
USB7051	4-Port USB3.1 Gen1 Hub with USB power delivery on 2 ports	Enabled by default on port 6
USB7052	4-Port USB3.1 Gen1 Hub with USB power delivery on 1 port	Enabled by default on port 6
USB7056	6-Port USB3.1 Gen1 Hub with USB power delivery on 1 port	Enabled by default on port 8

The Hub Feature Controller is connected to an extra internal port in the hub. It is mapped to the highest numbered port on the hub by default.

The Hub Feature Controller example for the USB7002 is illustrated in [Figure 1](#), while the Hub Feature Controller example for the USB7050, USB7051, and USB7052 is in [Figure 2](#). A sample of the Hub Feature Controller for USB7056 is shown in [Figure 3](#).

FIGURE 1: USB7002 HUB FEATURE CONTROLLER EXAMPLE

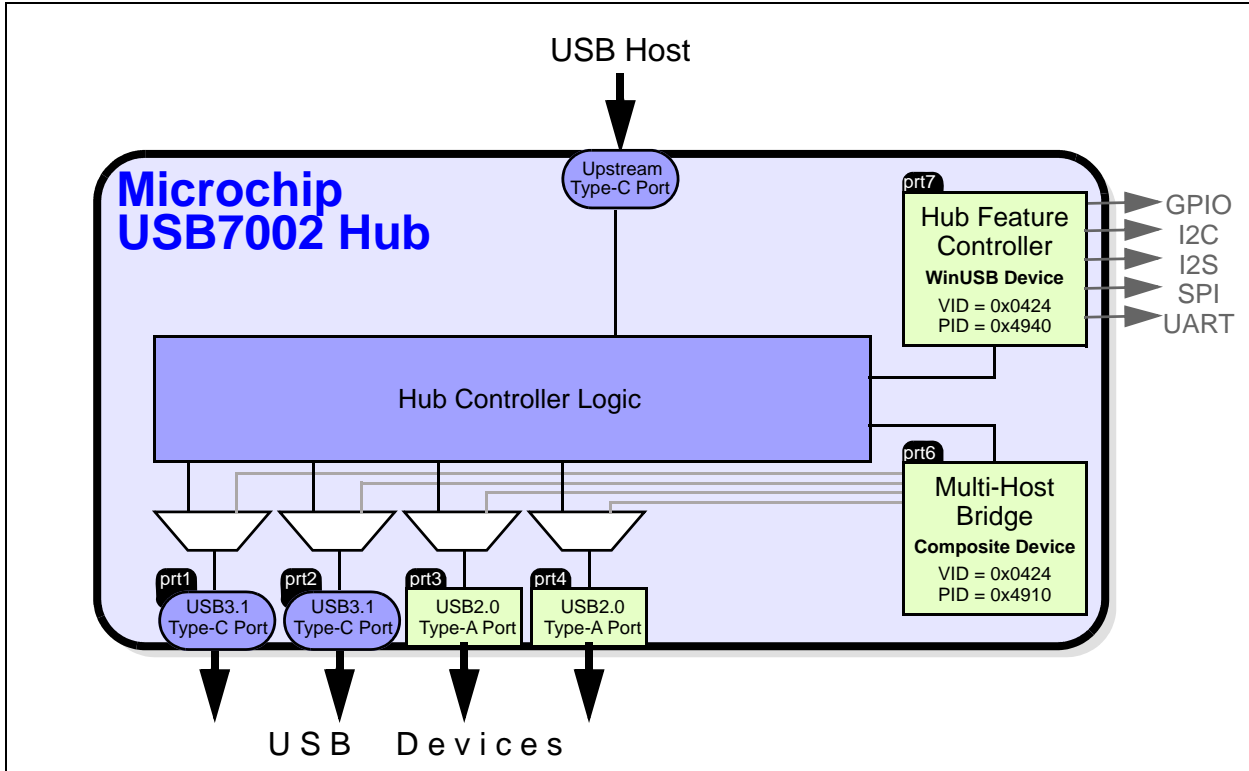

FIGURE 2: USB7050, USB7051, AND USB7052 HUB FEATURE CONTROLLER EXAMPLE

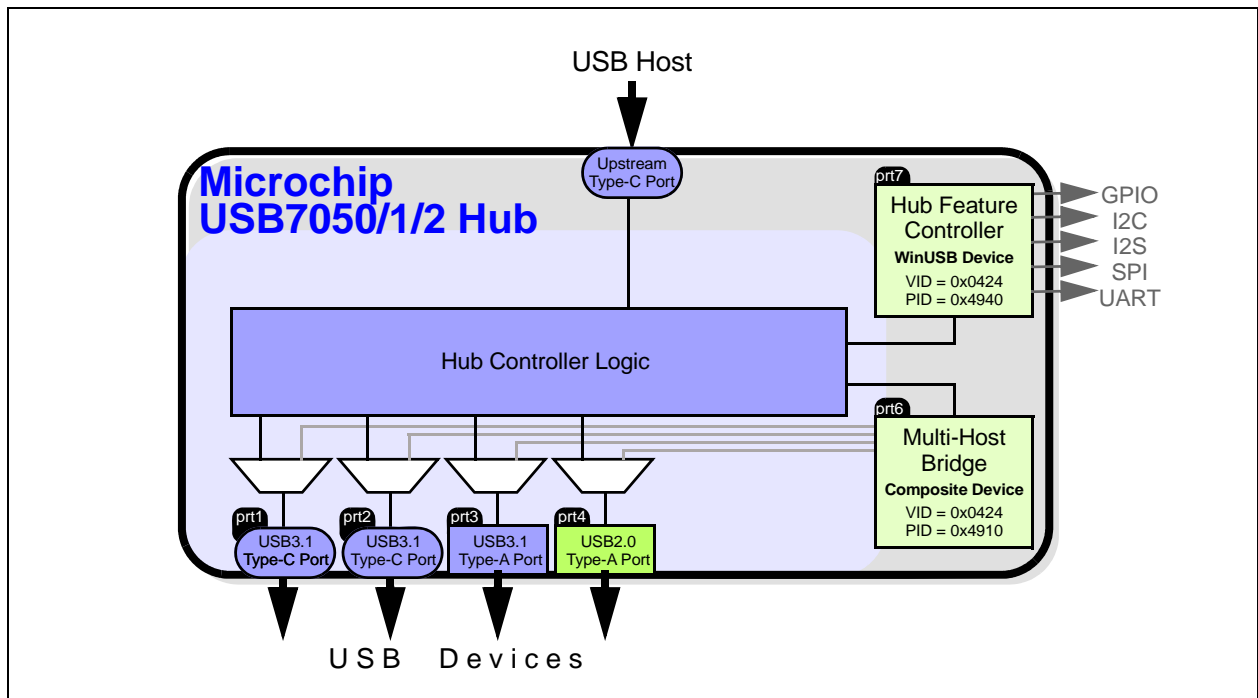
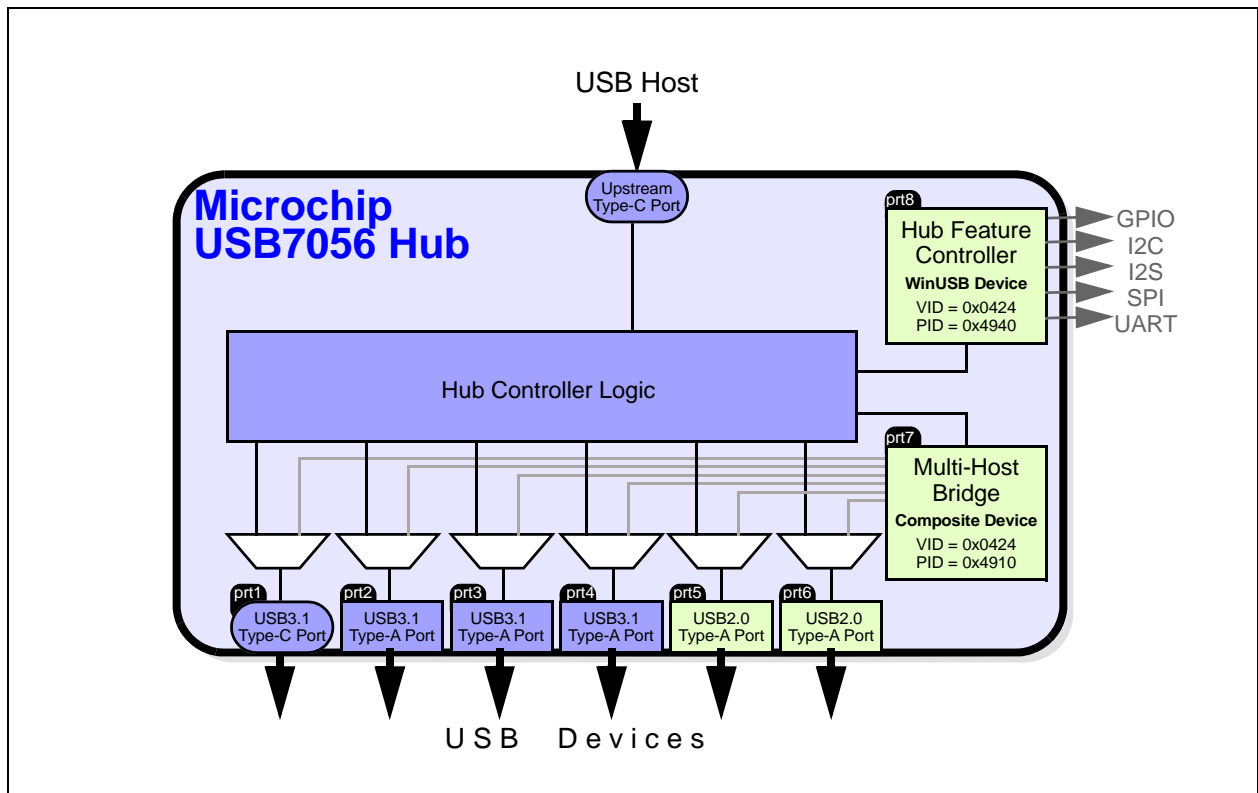

FIGURE 3: USB7056 HUB FEATURE CONTROLLER EXAMPLE



AN2750

The following GPIO functions are supported:

- [Set the GPIO Direction \(Input or Output\)](#)
- [Enable GPIO Internal Pull-up Resistor](#)
- [Enable GPIO Internal Pull-down Resistor](#)
- [GPIO Read State \(Input Mode\)](#)
- [GPIO Set State \(Output Mode\)](#)

Set the GPIO Direction (Input or Output)

Each GPIO can be configured as either a Schmitt-triggered input or output with an 8 mA sink/source.

Enable GPIO Internal Pull-up Resistor

Each GPIO can be enabled with a 50 uA (typical) internal pull-up resistor. Internal pull-up resistors prevent unconnected inputs from floating. The pull-up is only 67k, so it may not be strong enough to drive a load of less than 100k. When connected to a load that must be pulled high, an external resistor must be added.

Enable GPIO Internal Pull-down Resistor

Each GPIO can be enabled with a 50 uA (typical) internal pull-down resistor. Internal pull-down resistors prevent unconnected inputs from floating. The pull-down is only 67k, so it may not be strong enough to drive a load of less than 100k. When connected to a load that must be pulled low, an external resistor must be added.

GPIO Read State (Input Mode)

Read a 0: GPIO is below 0.9V.

Read a 1: GPIO is above 1.9V.

Note: When configured as an input, the GPIOs are digital Schmitt-triggered inputs. The range 0.8V to 2.0V is an indeterminate input state, so 3.3V-to-2.5V signaling is supported.

GPIO Set State (Output Mode)

Set to 0: GPIO Drives to 0.0V. When driven low, an 8 mA sink is enabled, driving the pin to 0.4V or lower.

Set to 1: GPIO Drives to 3.3V. When driven high, an 8 mA source is enabled, driving the pin to VDD33 to 0.4V or higher.

PART NUMBER-SPECIFIC INFORMATION

Part Summary

Table 2 summarizes the total number of available GPIOs by part number. Many of the GPIOs on the hub are only available after configuration. The following methods may be used to configure the hub:

- **ProTouch:** If configuring via internal One-Time Programmable (OTP) memory or SPI EEPROM with a base firmware file
- **SMBus/I²C Configuration:** If using an embedded SoC/I²C EEPROM to configure the hub at each start-up/reset
- **Pin Strapping:** Many of the GPIOs are made available by specific pin strapping or by simply not populating an SPI EEPROM device.

TABLE 2: GPIO AVAILABILITY SUMMARY

	USB7002	USB7050	USB7051	USB7052	USB7056
Minimum GPIOs Available	4 (CONFIG2)	8 (CONFIG1)	4 (CONFIG3)	1 (CONFIG3)	1 (CONFIG2)
Maximum GPIOs Available	12 (CONFIG4)	14 (CONFIG4)	11 (CONFIG4)	8 (CONFIG4)	2 (CONFIG1)

TABLE 3: USB7002 GPIOs

	CONFIG1 (I ² C)	CONFIG2 (I ² S)	CONFIG3 (UART)	CONFIG4 (FLEX)
PF6	GPIO70	GPIO70	UART_RX	GPIO70
PF7	GPIO71	MIC_DET	UART_TX	GPIO71
PF12	GPIO76	—	—	GPIO76
PF14	GPIO78	I2S_SDI	UART_nCTS	GPIO78
PF18	MSTR_I2C_CLK	I2S_LRCK	UART_nDCD	GPIO82
PF19	MSTR_I2C_DATA	I2S_SDO	UART_nRTS	GPIO83
PF26	SLV_I2C_CLK	I2S_SCK	UART_nDSR	GPIO90
PF27	SLV_I2C_DATA	I2S_MCLK	UART_nDTR	GPIO91
PF28	GPIO92	GPIO92	GPIO92	GPIO92
PF29	GPIO93	GPIO93	GPIO93	GPIO93
PF30	GPIO94	MSTR_I2C_CLK	GPIO94	GPIO94
PF31	GPIO95	MSTR_I2C_DATA	GPIO95	GPIO95

AN2750

TABLE 4: USB7050 GPIOs

	CONFIG1 (I ² C)	CONFIG2 (I ² S)	CONFIG3 (UART)	CONFIG4 (FLEX)	CONFIG5
PF2	GPIO66	GPIO66	UART_nCTS	GPIO66	GPIO66
PF3	GPIO67	I2S_SDI	UART_nRTS	GPIO67	GPIO67
PF4	PD_SPI_CE_N2	I2S_SDO	UART_nDSR	GPIO68	GPIO68
PF5	PD_SPI_CE_N1	I2S_SCK	UART_nDTR	GPIO69	GPIO69
PF6	PD_SPI_CE_N0	I2S_LRCK	UART_RX	GPIO70	GPIO70
PF7	PD_SPI_CLK	I2S_MCLK	UART_TX	GPIO71	GPIO71
PF14	GPIO78	GPIO78	GPIO78	GPIO78	GPIO78
PF19	SLV_I2C_DATA	SLV_I2C_DATA	SLV_I2C_DATA	GPIO83	SLV_I2C_DATA
PF26	SLV_I2C_CLK	SLV_I2C_CLK	SLV_I2C_CLK	GPIO90	SLV_I2C_CLK
PF27	GPIO91	MIC_DET	GPIO91	GPIO91	GPIO91
PF28	GPIO92	GPIO92	GPIO92	GPIO92	GPIO92
PF29	GPIO93	GPIO93	GPIO93	GPIO93	GPIO93
PF30	GPIO94	GPIO94	GPIO94	GPIO94	GPIO94
PF31	GPIO95	GPIO95	GPIO95	GPIO95	GPIO95

TABLE 5: USB7051 GPIOs

	CONFIG1 (I ² C)	CONFIG2 (I ² S)	CONFIG3 (UART)	CONFIG4 (FLEX)
PF4	GPIO68	GPIO68	GPIO68	GPIO68
PF6	GPIO70	GPIO70	UART_RX	GPIO70
PF7	GPIO71	MIC_DET	UART_TX	GPIO71
PF14	GPIO78	I2S_SDI	UART_nCTS	GPIO78
PF19	SLV_I2C_DATA	I2S_SDO	UART_nRTS	GPIO83
PF26	SLV_I2C_CLK	I2S_SCK	UART_nDSR	GPIO90
PF27	GPIO91	I2S_MCLK	UART_nDTR	GPIO91
PF28	GPIO92	I2S_LRCK	UART_nDCD	GPIO92
PF29	GPIO93	GPIO93	GPIO93	GPIO93
PF30	GPIO94	GPIO94	GPIO94	GPIO94
PF31	GPIO95	GPIO95	GPIO95	GPIO95

TABLE 6: USB7052 GPIOs

	CONFIG1 (I²C)	CONFIG2 (I²S)	CONFIG3 (UART)	CONFIG4 (FLEX)
PF6	GPIO70	GPIO70	<i>UART_RX</i>	GPIO70
PF7	GPIO71	<i>MIC_DET</i>	<i>UART_TX</i>	GPIO71
PF14	GPIO78	<i>I2S_SDI</i>	<i>UART_nCTS</i>	GPIO78
PF19	SLV_I2C_DATA	I2S_SDO	<i>UART_nRTS</i>	GPIO83
PF26	<i>SLV_I2C_CLK</i>	I2S_SCK	<i>UART_nDSR</i>	GPIO90
PF27	GPIO91	I2S_MCLK	<i>UART_nDTR</i>	GPIO91
PF28	GPIO92	I2S_LRCK	<i>UART_nDCD</i>	GPIO92
PF29	GPIO93	GPIO93	GPIO93	GPIO93

TABLE 7: USB7056 GPIOs

	CONFIG1 (I²C)	CONFIG2 (I²S)
PF6	GPIO70	GPIO70
PF7	GPIO71	<i>MIC_DET</i>

AN2750

SDK IMPLEMENTATION

The simplest method for implementing the USB-to-GPIO Bridging functions is to use the publicly available DLL which is distributed with the MPLAB[®] Connect Configurator tool. The DLL is compatible with Windows operating systems. Visit the USB705xx product page on microchip.com to download MPLAB Connect with the DLL package. Using the libraries available in the DLL, the Bridging features can be implemented in C-code.

The DLL package contains the following:

- User's guide (*MPLAB Connect DLL User's Guide*) with detailed description of how to use the DLL and call each function
- Release notes
- Library files:
 - For Windows: A ".dll" and a ".lib" file
 - For Linux: A ".cpp" file that can be built into a ".a" file
- Example code

Commands Included in the SDK

- **libMchpUsbGpioConfigureGPIO:** Configures a pin to behave as a GPIO
- **libMchpUsbGpioGet:** Sets the queried GPIO to an input (if not already set as such) and then reads the input state
- **libMchpUsbGpioSet:** Sets the queried GPIO to an output (if not already set as such) and then sets the output state

For additional details on how to use the SDK to implement USB-to-GPIO Bridging, download the SDK package and refer to the user's guide.

MANUAL IMPLEMENTATION

The USB-to-GPIO Bridging features may be implemented at the lowest level if you have the ability to build USB packets. This approach is required if you are not using a Windows or Linux host system and cannot use the SDK.

All USB-to-GPIO Bridging commands are accomplished with internal register writes and reads. Further details can be found in the Microchip application note, *Configuration Options for the USB70xx*. All USB to GPIO bridging commands must be sent directly to Endpoint 0 of the Hub Feature Controller connected to the last downstream port of the Microchip hub.

For details on the register read and write USB SETUP packets, refer to [Register Read](#) and [Register Write](#), respectively. The configuration register addresses and contents are detailed in [GPIO Configuration Register Map](#) and [Register Definitions](#).

Register Read

To read the state of a GPIO, a register read with the USB SETUP packet in [Table 8](#) must be used:

TABLE 8: REGISTER READ USB SETUP COMMAND

SETUP Parameter	Value	Description
bmRequestType	0xC0	Device-to-host, vendor class, targeted to interface
bRequest	0x04	Register read command: CMD_REG_READ
wValue	Register address LSB	Valid address range: <0x0000> to <0xFFFF> [64KB]
wIndex	Register address MSB	Valid address range: <0x0000> to <0xFFFF> [64KB]
wLength	Data length	Length of the data bytes to be retrieved

REGISTER READ USB TRANSACTION SEQUENCE

Command Phase: The Hub Feature Controller receives the SETUP packet with the parameters specified in [Table 8](#).

Data Phase: The Hub Feature Controller sends the data bytes of length wLength from the specified address.

Status Phase: The Hub Feature Controller sends ACK on the successful completion of register read.

Register Write

To configure the direction of a GPIO, pull-up/pull-down resistor settings, or set the output state of a GPIO, a register write command with the USB SETUP packet in [Table 9](#) must be used:

TABLE 9: REGISTER WRITE USB SETUP COMMAND

SETUP Parameter	Value	Description
bmRequestType	0x40	Host-to-device, vendor class, targeted to interface
bRequest	0x03	Register read command: CMD_REG_WRITE
wValue	Register address LSBs	Last four bytes of the 32-bit register address
wIndex	Register address MSBs	First four bytes of the 32-bit register address
wLength	Data length	Length of data bytes to write

REGISTER WRITE USB TRANSACTION SEQUENCE

Command Phase: The Hub Feature Controller receives the SETUP packet with the parameters specified in [Table 9](#).

Data Phase: The Hub Feature Controller receives the data bytes of length wLength to be written to the register starting from the specified address.

Status Phase: The Hub Feature Controller sends ACK on successful completion of register write.

AN2750

GPIO Configuration Register Map

TABLE 10: CONFIGURATION REGISTER MEMORY MAP

Address	Name	R/W	Function	Default
BF80 0908	PIO96_OEN	R/W	PIO[95:64] Output Enable Register	00h
BF80 0918	PIO96_IEN	R/W	PIO[95:64] Input Enable Register	00h
BF80 0928	PIO96_OUT	R/W	PIO[95:64] Output State Register	00h
BF80 0938	PIO96_IN	R	PIO[95:64] Input State Register	00h
BF80 0948	PIO96_PUE	R/W	PIO[95:64] Pull-up Enable Register	00h
BF80 0958	PIO96_PDE	R/W	PIO[95:64] Pulldown Enable Register	00h

Register Definitions

TABLE 11: PIO[95:64] OUTPUT ENABLE REGISTER

PIO96_OEN (BF80 0908h)			PIO[95:64] Output Enable Register
Bit	Name	R/W	Description
31	GPIO_95_OE	R/W	Set bit to enable GPIO95 as an output.
30	GPIO_94_OE	R/W	Set bit to enable GPIO94 as an output.
29	GPIO_93_OE	R/W	Set bit to enable GPIO93 as an output.
28	GPIO_92_OE	R/W	Set bit to enable GPIO92 as an output.
27	GPIO_91_OE	R/W	Set bit to enable GPIO91 as an output.
26	GPIO_90_OE	R/W	Set bit to enable GPIO90 as an output.
25:20	Reserved	R	Reserved
19	GPIO_83_OE	R/W	Set bit to enable GPIO83 as an output.
18	GPIO_82_OE	R/W	Set bit to enable GPIO82 as an output.
17:15	Reserved	R	Reserved
14	GPIO_78_OE	R/W	Set bit to enable GPIO78 as an output.
13	Reserved	R	Reserved
12	GPIO_76_OE	R/W	Set bit to enable GPIO76 as an output.
11:8	Reserved	R	Reserved
7	GPIO_71_OE	R/W	Set bit to enable GPIO71 as an output.
6	GPIO_70_OE	R/W	Set bit to enable GPIO70 as an output.
5	GPIO_69_OE	R/W	Set bit to enable GPIO69 as an output.
4	GPIO_68_OE	R/W	Set bit to enable GPIO68 as an output.
3	GPIO_67_OE	R/W	Set bit to enable GPIO67 as an output.
2	GPIO_66_OE	R/W	Set bit to enable GPIO66 as an output.
1:0	Reserved	R	Reserved
Note: BF80_0908h: GPIO66-71; BF80_0909h: GPIO76-78; BF80_090Ah: GPIO82-83; BF80_090Bh: GPIO 90-92			

TABLE 12: PIO[95:64] INPUT ENABLE REGISTER

PIO96_IEN (BF80_0918h)			PIO[95:64] Input Enable Register
Bit	Name	R/W	Description
31	GPIO_95_IE	R/W	Set bit to enable GPIO95 as an input.
30	GPIO_94_IE	R/W	Set bit to enable GPIO94 as an input.
29	GPIO_93_IE	R/W	Set bit to enable GPIO93 as an input.
28	GPIO_92_IE	R/W	Set bit to enable GPIO92 as an input.
27	GPIO_91_IE	R/W	Set bit to enable GPIO91 as an input.
26	GPIO_90_IE	R/W	Set bit to enable GPIO90 as an input.
25:20	Reserved	R	Reserved
19	GPIO_83_IE	R/W	Set bit to enable GPIO83 as an input.
18	GPIO_82_IE	R/W	Set bit to enable GPIO82 as an input.
17:15	Reserved	R	Reserved
14	GPIO_78_IE	R/W	Set bit to enable GPIO78 as an input.
13	Reserved	R	Reserved
12	GPIO_76_IE	R/W	Set bit to enable GPIO76 as an input.
11:8	Reserved	R	Reserved
7	GPIO_71_IE	R/W	Set bit to enable GPIO71 as an input.
6	GPIO_70_IE	R/W	Set bit to enable GPIO70 as an input.
5	GPIO_69_IE	R/W	Set bit to enable GPIO69 as an input.
4	GPIO_68_IE	R/W	Set bit to enable GPIO68 as an input.
3	GPIO_67_IE	R/W	Set bit to enable GPIO67 as an input.
2	GPIO_66_IE	R/W	Set bit to enable GPIO66 as an input.
1:0	Reserved	R	Reserved
Note: BF80_0918h: GPIO66-71; BF80_0919h: GPIO76-78; BF80_091Ah: GPIO82-83; BF80_091Bh: GPIO 90-92			

AN2750

TABLE 13: PIO[95:64] OUTPUT STATE REGISTER

PIO96_OUT (BF80_0928h)			PIO[95:64] Output State Register
Bit	Name	R/W	Description
31	GPIO_95_OS	R/W	Set bit to drive GPIO95 high. Clear bit to drive GPIO95 low.
30	GPIO_94_OS	R/W	Set bit to drive GPIO94 high. Clear bit to drive GPIO94 low.
29	GPIO_93_OS	R/W	Set bit to drive GPIO93 high. Clear bit to drive GPIO93 low.
28	GPIO_92_OS	R/W	Set bit to drive GPIO92 high. Clear bit to drive GPIO92 low.
27	GPIO_91_OS	R/W	Set bit to drive GPIO91 high. Clear bit to drive GPIO91 low.
26	GPIO_90_OS	R/W	Set bit to drive GPIO90 high. Clear bit to drive GPIO90 low.
25:20	Reserved	R	Reserved
19	GPIO_83_OS	R/W	Set bit to drive GPIO83 high. Clear bit to drive GPIO83 low.
18	GPIO_82_OS	R/W	Set bit to drive GPIO82 high. Clear bit to drive GPIO82 low.
17:15	Reserved	R	Reserved
14	GPIO_78_OS	R/W	Set bit to drive GPIO78 high. Clear bit to drive GPIO78 low.
13	Reserved	R	Reserved
12	GPIO_76_OS	R/W	Set bit to drive GPIO76 high. Clear bit to drive GPIO76 low.
11:8	Reserved	R	Reserved
7	GPIO_71_OS	R/W	Set bit to drive GPIO71 high. Clear bit to drive GPIO71 low.
6	GPIO_70_OS	R/W	Set bit to drive GPIO70 high. Clear bit to drive GPIO70 low.
5	GPIO_69_OS	R/W	Set bit to drive GPIO69 high. Clear bit to drive GPIO69 low.
4	GPIO_68_OS	R/W	Set bit to drive GPIO68 high. Clear bit to drive GPIO68 low.
3	GPIO_67_OS	R/W	Set bit to drive GPIO67 high. Clear bit to drive GPIO67 low.
2	GPIO_66_OS	R/W	Set bit to drive GPIO66 high. Clear bit to drive GPIO66 low.
1:0	Reserved	R	Reserved
Note: BF80_0928h: GPIO66-71; BF80_0929h: GPIO76-78; BF80_092Ah: GPIO82-83; BF80_092Bh: GPIO 90-92			

TABLE 14: PIO[95:64] INPUT STATE REGISTER

PIO96_IN (BF80 0938h)			PIO[95:64] Input State Register
Bit	Name	R/W	Description
31	GPIO_95_IS	R/W	Read bit to determine input state of GPIO95.
30	GPIO_94_IS	R/W	Read bit to determine input state of GPIO94.
29	GPIO_93_IS	R/W	Read bit to determine input state of GPIO93.
28	GPIO_92_IS	R/W	Read bit to determine input state of GPIO92.
27	GPIO_91_IS	R/W	Read bit to determine input state of GPIO91.
26	GPIO_90_IS	R/W	Read bit to determine input state of GPIO90.
25:20	Reserved	R	Reserved
19	GPIO_83_IS	R/W	Read bit to determine input state of GPIO83.
18	GPIO_82_IS	R/W	Read bit to determine input state of GPIO82.
17:15	Reserved	R	Reserved
14	GPIO_78_IS	R/W	Read bit to determine input state of GPIO78.
13	Reserved	R	Reserved
12	GPIO_76_IS	R/W	Read bit to determine input state of GPIO76.
11:8	Reserved	R	Reserved
7	GPIO_71_IS	R/W	Read bit to determine input state of GPIO71.
6	GPIO_70_IS	R/W	Read bit to determine input state of GPIO70.
5	GPIO_69_IS	R/W	Read bit to determine input state of GPIO69.
4	GPIO_68_IS	R/W	Read bit to determine input state of GPIO68.
3	GPIO_67_IS	R/W	Read bit to determine input state of GPIO67.
2	GPIO_66_IS	R/W	Read bit to determine input state of GPIO66.
1:0	Reserved	R	Reserved
Note: BF80_0938h: GPIO66-71; BF80_0939h: GPIO76-78; BF80_093Ah: GPIO82-83; BF80_093Bh: GPIO90-92			

TABLE 15: PIO[95:64] PULL-UP ENABLE REGISTER

PIO96_PUE (BF80 0948h)			PIO[95:64] Pull-Up Resistor Register
Bit	Name	R/W	Description
31	GPIO_95_PUE	R/W	Set bit to enable ~62k pull-up resistor on GPIO95.
30	GPIO_94_PUE	R/W	Set bit to enable ~62k pull-up resistor on GPIO94.
29	GPIO_93_PUE	R/W	Set bit to enable ~62k pull-up resistor on GPIO93.
28	GPIO_92_PUE	R/W	Set bit to enable ~62k pull-up resistor on GPIO92.
27	GPIO_91_PUE	R/W	Set bit to enable ~62k pull-up resistor on GPIO91.
26	GPIO_90_PUE	R/W	Set bit to enable ~62k pull-up resistor on GPIO90.
25:20	Reserved	R	Reserved
19	GPIO_83_PUE	R/W	Set bit to enable ~62k pull-up resistor on GPIO83.
18	GPIO_82_PUE	R/W	Set bit to enable ~62k pull-up resistor on GPIO82.
17:15	Reserved	R	Reserved
14	GPIO_78_PUE	R/W	Set bit to enable ~62k pull-up resistor on GPIO78.
13	Reserved	R	Reserved
12	GPIO_76_PUE	R/W	Set bit to enable ~62k pull-up resistor on GPIO76.
11:8	Reserved	R	Reserved
7	GPIO_71_PUE	R/W	Set bit to enable ~62k pull-up resistor on GPIO71.
6	GPIO_70_PUE	R/W	Set bit to enable ~62k pull-up resistor on GPIO70.
5	GPIO_69_PUE	R/W	Set bit to enable ~62k pull-up resistor on GPIO69.
4	GPIO_68_PUE	R/W	Set bit to enable ~62k pull-up resistor on GPIO68.
3	GPIO_67_PUE	R/W	Set bit to enable ~62k pull-up resistor on GPIO67.
2	GPIO_66_PUE	R/W	Set bit to enable ~62k pull-up resistor on GPIO66.
1:0	Reserved	R	Reserved
Note: BF80_0948h: GPIO66-71; BF80_0949h: GPIO76-78; BF80_094Ah: GPIO82-83; BF80_094Bh: GPIO 90-92			

TABLE 16: PIO[95:64] PULLDOWN ENABLE REGISTER

PIO96_PDE (BF80 0958h)			PIO[95:64] Pull-Down Resistor Register
BIT	Name	R/W	Description
31	GPIO_95_PDE	R/W	Set bit to enable ~62k pull-down resistor on GPIO95.
30	GPIO_94_PDE	R/W	Set bit to enable ~62k pull-down resistor on GPIO94.
29	GPIO_93_PDE	R/W	Set bit to enable ~62k pull-down resistor on GPIO93.
28	GPIO_92_PDE	R/W	Set bit to enable ~62k pull-down resistor on GPIO92.
27	GPIO_91_PDE	R/W	Set bit to enable ~62k pull-down resistor on GPIO91.
26	GPIO_90_PDE	R/W	Set bit to enable ~62k pull-down resistor on GPIO90.
25:20	Reserved	R	Reserved
19	GPIO_83_PDE	R/W	Set bit to enable ~62k pull-down resistor on GPIO83.
18	GPIO_82_PDE	R/W	Set bit to enable ~62k pull-down resistor on GPIO82.
17:15	Reserved	R	Reserved
14	GPIO_78_PDE	R/W	Set bit to enable ~62k pull-down resistor on GPIO78.
13	Reserved	R	Reserved
12	GPIO_76_PDE	R/W	Set bit to enable ~62k pull-down resistor on GPIO76.
11:8	Reserved	R	Reserved
7	GPIO_71_PDE	R/W	Set bit to enable ~62k pull-down resistor on GPIO71.
6	GPIO_70_PDE	R/W	Set bit to enable ~62k pull-down resistor on GPIO70.
5	GPIO_69_PDE	R/W	Set bit to enable ~62k pull-down resistor on GPIO69.
4	GPIO_68_PDE	R/W	Set bit to enable ~62k pull-down resistor on GPIO68.
3	GPIO_67_PDE	R/W	Set bit to enable ~62k pull-down resistor on GPIO67.
2	GPIO_66_PDE	R/W	Set bit to enable ~62k pull-down resistor on GPIO66.
1:0	Reserved	R	Reserved
Note: BF80_0958h: GPIO66-71; BF80_0959h: GPIO76-78; BF80_095Ah: GPIO82-83; BF80_095Bh: GPIO 90-92			

EXAMPLES

Read the Input State of PF7/GPIO71

- Command Phase (SETUP Transaction):** Send the following SETUP Register Read Command to Endpoint 0 of the Hub Feature Controller to read the contents of registers 0xBF80_0938 (PIO[95:64] Input State Register) which contains the input state information for PF7/GPIO71 (assuming that the GPIO was already configured as an input in a previous command). See [Table 17](#) and [Figure 4](#).

TABLE 17: REGISTER READ SETUP COMMAND EXAMPLE

SETUP Parameter	Value	Note
bmRequestType	0xC0	—
bRequest	0x04	—
wValue	0x0938	Last four bytes of the register address
wIndex	0xBF80	First four bytes of the register address
wLength	0x0001	One register to be read

FIGURE 4: REGISTER READ SETUP TRANSACTION EXAMPLE

Transaction	H	S	SETUP	ADDR	ENDP	T	D	TP	R	bRequest	wValue	wIndex	wLength	ACK	Time Stamp	
653			0xB4	6	0	0	D→H	V	D	0x04	0x0938	0xBF80	1	0x4B	2 . 649 476 716	
Packet	H	S	SETUP	ADDR	ENDP	CRC5	Pkt Len	Duration	Idle	Time Stamp						
22218			0xB4	6	0	0x09	8	133.333 ns	200.660 ns	2 . 649 476 716						
Packet	H	S	DATA0	Data				CRC16	Pkt Len	Duration	Idle	Time Stamp				
22219			0xC3	C0	04	38	09	80	BF	01	00	0xEC96	16	266.667 ns	333.330 ns	2 . 649 477 050
Packet	H	S	ACK	Pkt Len	Duration	Time	Time Stamp									
22220			0x4B	6	100.000 ns	1.600 us	2 . 649 477 650									

- Data Phase (IN Transaction):** The Hub Feature Controller sends the data bytes of length wLength starting from the specified address after receiving an IN packet. The returned value is 0x80, which indicates that PF7/GPIO71 is high. See [Figure 5](#).

FIGURE 5: REGISTER READ IN TRANSACTION EXAMPLE

Transaction	H	S	IN	ADDR	ENDP	T	Data	ACK	Time Stamp						
656			0x96	6	0	1	1 byte	0x4B	2 . 649 521 650						
Packet	H	S	IN	ADDR	ENDP	CRC5	Pkt Len	Duration	Idle	Time Stamp					
22225			0x96	6	0	0x09	8	133.333 ns	366.660 ns	2 . 649 521 650					
Packet	H	S	DATA1	Data	CRC16	Pkt Len	Duration	Idle	Time Stamp						
22226			0xD2	80	0x82F8	10	166.667 ns	333.330 ns	2 . 649 522 150						
Packet	H	S	ACK	Pkt Len	Duration	Time	Time Stamp								
22227			0x4B	8	133.333 ns	11.166 us	2 . 649 522 650								

- Status Phase (OUT Transaction):** The Host sends an OUT packet to complete the USB Transfer. The Hub Feature Controller responds with a zero-length data packet. Refer to [Figure 6](#).

FIGURE 6: REGISTER READ OUT TRANSACTION EXAMPLE

Transaction	H	S	OUT	ADDR	ENDP	T	Data	ACK	Time Stamp						
657			0x87	6	0	1	0 bytes	0x4B	2 . 649 533 816						
Packet	H	S	OUT	ADDR	ENDP	CRC5	Pkt Len	Duration	Idle	Time Stamp					
22228			0x87	6	0	0x09	8	133.333 ns	200.660 ns	2 . 649 533 816					
Packet	H	S	DATA1	Data	CRC16	Pkt Len	Duration	Idle	Time Stamp						
22229			0xD2	0 bytes	0x0000	8	133.333 ns	332.660 ns	2 . 649 534 150						
Packet	H	S	ACK	Pkt Len	Duration	Time	Time Stamp								
22230			0x4B	8	133.333 ns	2 . 649 534 616									

Write Registers to Set PF7/GPIO71 Output State as High

- Command Phase (SETUP Transaction):** Send the following SETUP Register Write Command to Endpoint 0 of the Hub Feature Controller to write the contents of register 0xBF80_0928 (PIO[95:64] Output State Register). In this example, PF7/GPIO71 is set high (assuming that the GPIO was already configured as an output in a previous command). See [Table 18](#) and [Figure 7](#).

TABLE 18: REGISTER WRITE SETUP COMMAND EXAMPLE

SETUP Parameter	Value	Note
bmRequestType	0x40	—
bRequest	0x03	—
wValue	0x0928	Last 4 bytes of the register address
wIndex	0xBF80	First 4 bytes of the register address
wLength	0x0001	One register is to be read

FIGURE 7: REGISTER WRITE SETUP TRANSACTION EXAMPLE

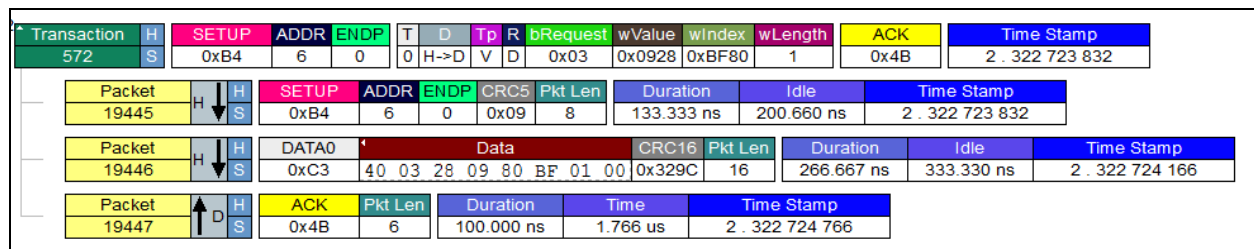

- Data Phase (OUT Transaction):** The Host sends the data byte to set 0xBF80_0928 = 0x80 from the specified address after sending the OUT packet to set the PF7/GPIO71 output as high. Refer to [Figure 8](#).

FIGURE 8: REGISTER WRITE OUT TRANSACTION EXAMPLE

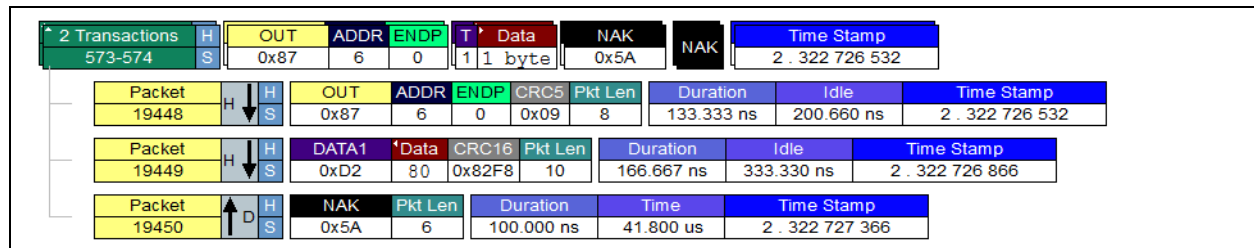

- Status Phase (OUT Transaction):** The Host sends an IN packet to complete the USB Transfer. The Hub Feature Controller responds with a zero-length data packet. See [Figure 9](#).

FIGURE 9: REGISTER WRITE IN TRANSACTION EXAMPLE

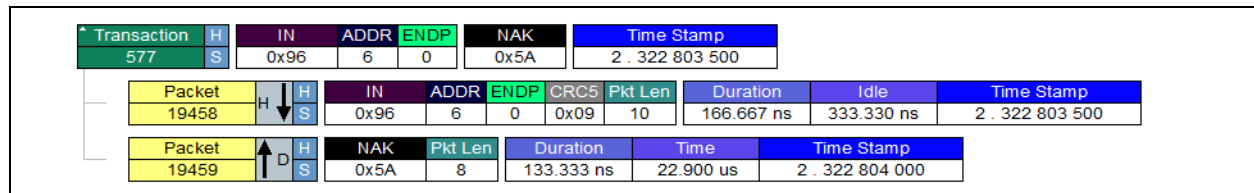

AN2750

NOTES:

APPENDIX A: APPLICATION NOTE REVISION HISTORY

TABLE A-1: REVISION HISTORY

Revision Level and Date	Section/Figure/Entry	Correction
DS00002750A (07-13-18)	All	Initial release

THE MICROCHIP WEBSITE

Microchip provides online support via our WWW site at www.microchip.com. This website is used as a means to make files and information easily available to customers. Accessible by using your favorite Internet browser, the website contains the following information:

- **Product Support** – Data sheets and errata, application notes and sample programs, design resources, user's guides and hardware support documents, latest software releases, and archived software
- **General Technical Support** – Frequently Asked Questions (FAQ), technical support requests, online discussion groups, and Microchip consultant program member listing
- **Business of Microchip** – Product selector and ordering guides, latest Microchip press releases, listing of seminars and events, and listings of Microchip sales offices, distributors, and factory representatives

CUSTOMER CHANGE NOTIFICATION SERVICE

Microchip's customer notification service helps keep customers current on Microchip products. Subscribers will receive e-mail notification whenever there are changes, updates, revisions, or errata related to a specified product family or development tool of interest.

To register, access the Microchip website at www.microchip.com. Under "Support", click on "Customer Change Notification" and follow the registration instructions.

CUSTOMER SUPPORT

Users of Microchip products can receive assistance through several channels:

- Distributor or Representative
- Local Sales Office
- Field Application Engineer (FAE)
- Technical Support

Customers should contact their distributor, representative, or Field Application Engineer (FAE) for support. Local sales offices are also available to help customers. A listing of sales offices and locations is included in the back of this document.

Technical support is available through the website at: <http://microchip.com/support>

Note the following details of the code protection feature on Microchip devices:

- Microchip products meet the specification contained in their particular Microchip Data Sheet.
- Microchip believes that its family of products is one of the most secure families of its kind on the market today, when used in the intended manner and under normal conditions.
- There are dishonest and possibly illegal methods used to breach the code protection feature. All of these methods, to our knowledge, require using the Microchip products in a manner outside the operating specifications contained in Microchip's Data Sheets. Most likely, the person doing so is engaged in theft of intellectual property.
- Microchip is willing to work with the customer who is concerned about the integrity of their code.
- Neither Microchip nor any other semiconductor manufacturer can guarantee the security of their code. Code protection does not mean that we are guaranteeing the product as “unbreakable.”

Code protection is constantly evolving. We at Microchip are committed to continuously improving the code protection features of our products. Attempts to break Microchip's code protection feature may be a violation of the Digital Millennium Copyright Act. If such acts allow unauthorized access to your software or other copyrighted work, you may have a right to sue for relief under that Act.

Information contained in this publication regarding device applications and the like is provided only for your convenience and may be superseded by updates. It is your responsibility to ensure that your application meets with your specifications. MICROCHIP MAKES NO REPRESENTATIONS OR WARRANTIES OF ANY KIND WHETHER EXPRESS OR IMPLIED, WRITTEN OR ORAL, STATUTORY OR OTHERWISE, RELATED TO THE INFORMATION, INCLUDING BUT NOT LIMITED TO ITS CONDITION, QUALITY, PERFORMANCE, MERCHANTABILITY OR FITNESS FOR PURPOSE. Microchip disclaims all liability arising from this information and its use. Use of Microchip devices in life support and/or safety applications is entirely at the buyer's risk, and the buyer agrees to defend, indemnify and hold harmless Microchip from any and all damages, claims, suits, or expenses resulting from such use. No licenses are conveyed, implicitly or otherwise, under any Microchip intellectual property rights unless otherwise stated.

Trademarks

The Microchip name and logo, the Microchip logo, AnyRate, AVR, AVR logo, AVR Freaks, BitCloud, chipKIT, chipKIT logo, CryptoMemory, CryptoRF, dsPIC, FlashFlex, flexPWR, Heldo, JukeBlox, KeeLoq, Klear, LANCheck, LINK MD, maXStylus, maXTouch, MediaLB, megaAVR, MOST, MOST logo, MPLAB, OptoLyzer, PIC, picoPower, PICSTART, PIC32 logo, Prochip Designer, QTouch, SAM-BA, SpyNIC, SST, SST Logo, SuperFlash, tinyAVR, UNI/O, and XMEGA are registered trademarks of Microchip Technology Incorporated in the U.S.A. and other countries.

ClockWorks, The Embedded Control Solutions Company, EtherSynch, Hyper Speed Control, HyperLight Load, IntellIMOS, mTouch, Precision Edge, and Quiet-Wire are registered trademarks of Microchip Technology Incorporated in the U.S.A.

Adjacent Key Suppression, AKS, Analog-for-the-Digital Age, Any Capacitor, AnyIn, AnyOut, BodyCom, CodeGuard, CryptoAuthentication, CryptoAutomotive, CryptoCompanion, CryptoController, dsPICDEM, dsPICDEM.net, Dynamic Average Matching, DAM, ECAN, EtherGREEN, In-Circuit Serial Programming, ICSP, INICnet, Inter-Chip Connectivity, JitterBlocker, KlearNet, KlearNet logo, memBrain, Mindi, MiWi, motorBench, MPASM, MPF, MPLAB Certified logo, MPLIB, MPLINK, MultiTRAK, NetDetach, Omniscient Code Generation, PICDEM, PICDEM.net, PICkit, PICtail, PowerSmart, PureSilicon, QMatrix, REAL ICE, Ripple Blocker, SAM-ICE, Serial Quad I/O, SMART-I.S., SQI, SuperSwitcher, SuperSwitcher II, Total Endurance, TSHARC, USBCheck, VariSense, ViewSpan, WiperLock, Wireless DNA, and ZENA are trademarks of Microchip Technology Incorporated in the U.S.A. and other countries.

SQTP is a service mark of Microchip Technology Incorporated in the U.S.A.

Silicon Storage Technology is a registered trademark of Microchip Technology Inc. in other countries.

GestIC is a registered trademark of Microchip Technology Germany II GmbH & Co. KG, a subsidiary of Microchip Technology Inc., in other countries.

All other trademarks mentioned herein are property of their respective companies.

© 2018, Microchip Technology Incorporated, All Rights Reserved.

ISBN: 978-1-5224-3320-0

QUALITY MANAGEMENT SYSTEM
CERTIFIED BY DNV
== ISO/TS 16949 ==

Microchip received ISO/TS-16949:2009 certification for its worldwide headquarters, design and wafer fabrication facilities in Chandler and Tempe, Arizona; Gresham, Oregon and design centers in California and India. The Company's quality system processes and procedures are for its PIC® MCUs and dsPIC® DSCs, KEELoC® code hopping devices, Serial EEPROMs, microperipherals, nonvolatile memory and analog products. In addition, Microchip's quality system for the design and manufacture of development systems is ISO 9001:2000 certified.



MICROCHIP

Worldwide Sales and Service

AMERICAS

Corporate Office
2355 West Chandler Blvd.
Chandler, AZ 85224-6199
Tel: 480-792-7200
Fax: 480-792-7277
Technical Support:
<http://www.microchip.com/support>
Web Address:
www.microchip.com

Atlanta

Duluth, GA
Tel: 678-957-9614
Fax: 678-957-1455

Austin, TX

Tel: 512-257-3370

Boston

Westborough, MA
Tel: 774-760-0087
Fax: 774-760-0088

Chicago

Itasca, IL
Tel: 630-285-0071
Fax: 630-285-0075

Dallas

Addison, TX
Tel: 972-818-7423
Fax: 972-818-2924

Detroit

Novi, MI
Tel: 248-848-4000

Houston, TX

Tel: 281-894-5983

Indianapolis

Noblesville, IN
Tel: 317-773-8323
Fax: 317-773-5453
Tel: 317-536-2380

Los Angeles

Mission Viejo, CA
Tel: 949-462-9523
Fax: 949-462-9608
Tel: 951-273-7800

Raleigh, NC

Tel: 919-844-7510

New York, NY

Tel: 631-435-6000

San Jose, CA

Tel: 408-735-9110
Tel: 408-436-4270

Canada - Toronto

Tel: 905-695-1980
Fax: 905-695-2078

ASIA/PACIFIC

Australia - Sydney
Tel: 61-2-9868-6733

China - Beijing
Tel: 86-10-8569-7000

China - Chengdu
Tel: 86-28-8665-5511

China - Chongqing
Tel: 86-23-8980-9588

China - Dongguan
Tel: 86-769-8702-9880

China - Guangzhou
Tel: 86-20-8755-8029

China - Hangzhou
Tel: 86-571-8792-8115

China - Hong Kong SAR
Tel: 852-2943-5100

China - Nanjing
Tel: 86-25-8473-2460

China - Qingdao
Tel: 86-532-8502-7355

China - Shanghai
Tel: 86-21-3326-8000

China - Shenyang
Tel: 86-24-2334-2829

China - Shenzhen
Tel: 86-755-8864-2200

China - Suzhou
Tel: 86-186-6233-1526

China - Wuhan
Tel: 86-27-5980-5300

China - Xian
Tel: 86-29-8833-7252

China - Xiamen
Tel: 86-592-2388138

China - Zhuhai
Tel: 86-756-3210040

ASIA/PACIFIC

India - Bangalore
Tel: 91-80-3090-4444

India - New Delhi
Tel: 91-11-4160-8631

India - Pune
Tel: 91-20-4121-0141

Japan - Osaka
Tel: 81-6-6152-7160

Japan - Tokyo
Tel: 81-3-6880-3770

Korea - Daegu
Tel: 82-53-744-4301

Korea - Seoul
Tel: 82-2-554-7200

Malaysia - Kuala Lumpur
Tel: 60-3-7651-7906

Malaysia - Penang
Tel: 60-4-227-8870

Philippines - Manila
Tel: 63-2-634-9065

Singapore
Tel: 65-6334-8870

Taiwan - Hsin Chu
Tel: 886-3-577-8366

Taiwan - Kaohsiung
Tel: 886-7-213-7830

Taiwan - Taipei
Tel: 886-2-2508-8600

Thailand - Bangkok
Tel: 66-2-694-1351

Vietnam - Ho Chi Minh
Tel: 84-28-5448-2100

EUROPE

Austria - Wels
Tel: 43-7242-2244-39
Fax: 43-7242-2244-393

Denmark - Copenhagen
Tel: 45-4450-2828
Fax: 45-4485-2829

Finland - Espoo
Tel: 358-9-4520-820

France - Paris
Tel: 33-1-69-53-63-20
Fax: 33-1-69-30-90-79

Germany - Garching
Tel: 49-8931-9700

Germany - Haan
Tel: 49-2129-3766400

Germany - Heilbronn
Tel: 49-7131-67-3636

Germany - Karlsruhe
Tel: 49-721-625370

Germany - Munich
Tel: 49-89-627-144-0
Fax: 49-89-627-144-44

Germany - Rosenheim
Tel: 49-8031-354-560

Israel - Ra'anana
Tel: 972-9-744-7705

Italy - Milan
Tel: 39-0331-742611
Fax: 39-0331-466781

Italy - Padova
Tel: 39-049-7625286

Netherlands - Drunen
Tel: 31-416-690399
Fax: 31-416-690340

Norway - Trondheim
Tel: 47-7289-7561

Poland - Warsaw
Tel: 48-22-3325737

Romania - Bucharest
Tel: 40-21-407-87-50

Spain - Madrid
Tel: 34-91-708-08-90
Fax: 34-91-708-08-91

Sweden - Gothenberg
Tel: 46-31-704-60-40

Sweden - Stockholm
Tel: 46-8-5090-4654

UK - Wokingham
Tel: 44-118-921-5800
Fax: 44-118-921-5820

Mouser Electronics

Authorized Distributor

Click to View Pricing, Inventory, Delivery & Lifecycle Information:

Microchip:

[USB7051T-I/KDX](#) [USB7052/KDX](#) [USB7052-I/KDX](#) [USB7052T/KDX](#) [USB7052T-I/KDX](#) [USB7050T/KDX](#) [USB7050T-I/KDX](#) [USB7051/KDX](#) [USB7051-I/KDX](#) [USB7051T/KDX](#) [USB7056/KDX](#) [USB7056-I/KDX](#) [USB7056T/KDX](#) [USB7056T-I/KDX](#) [USB7050/KDX](#) [USB7050-I/KDX](#)

Компания «Океан Электроники» предлагает заключение долгосрочных отношений при поставках импортных электронных компонентов на взаимовыгодных условиях!

Наши преимущества:

- Поставка оригинальных импортных электронных компонентов напрямую с производств Америки, Европы и Азии, а так же с крупнейших складов мира;
- Широкая линейка поставок активных и пассивных импортных электронных компонентов (более 30 млн. наименований);
- Поставка сложных, дефицитных, либо снятых с производства позиций;
- Оперативные сроки поставки под заказ (от 5 рабочих дней);
- Экспресс доставка в любую точку России;
- Помощь Конструкторского Отдела и консультации квалифицированных инженеров;
- Техническая поддержка проекта, помощь в подборе аналогов, поставка прототипов;
- Поставка электронных компонентов под контролем ВП;
- Система менеджмента качества сертифицирована по Международному стандарту ISO 9001;
- При необходимости вся продукция военного и аэрокосмического назначения проходит испытания и сертификацию в лаборатории (по согласованию с заказчиком);
- Поставка специализированных компонентов военного и аэрокосмического уровня качества (Xilinx, Altera, Analog Devices, Intersil, Interpoint, Microsemi, Actel, Aeroflex, Peregrine, VPT, Syfer, Eurofarad, Texas Instruments, MS Kennedy, Miteq, Cobham, E2V, MA-COM, Hittite, Mini-Circuits, General Dynamics и др.);

Компания «Океан Электроники» является официальным дистрибьютором и эксклюзивным представителем в России одного из крупнейших производителей разъемов военного и аэрокосмического назначения «JONHON», а так же официальным дистрибьютором и эксклюзивным представителем в России производителя высокотехнологичных и надежных решений для передачи СВЧ сигналов «FORSTAR».



JONHON

«JONHON» (основан в 1970 г.)

Разъемы специального, военного и аэрокосмического назначения:

(Применяются в военной, авиационной, аэрокосмической, морской, железнодорожной, горно- и нефтедобывающей отраслях промышленности)

«FORSTAR» (основан в 1998 г.)

ВЧ соединители, коаксиальные кабели, кабельные сборки и микроволновые компоненты:

(Применяются в телекоммуникациях гражданского и специального назначения, в средствах связи, РЛС, а так же военной, авиационной и аэрокосмической отраслях промышленности).



Телефон: 8 (812) 309-75-97 (многоканальный)

Факс: 8 (812) 320-03-32

Электронная почта: ocean@oceanchips.ru

Web: <http://oceanchips.ru/>

Адрес: 198099, г. Санкт-Петербург, ул. Калинина, д. 2, корп. 4, лит. А