

High Radiant Flux Deep Red LED Emitter

LZ4-00R208

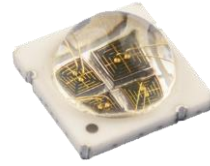

Key Features

- High flux output Deep Red 660nm LED
- 15.9 μ mol/s output at 6.6W power dissipation
- Ultra-small foot print – 7.0mm x 7.0mm
- Surface mount ceramic package with integrated glass lens
- Low Thermal Resistance (2.8°C/W)
- Individually addressable die
- Autoclave compliant (JEDEC JESD22-A102-C)
- JEDEC Level 1 for Moisture Sensitivity Level
- Lead (Pb) free and RoHS compliant
- Reflow solderable
- Emitter available on Standard or Serially Connected MCPCB (optional)

Typical Applications

- Horticulture
- Photo Therapy
- Machine Vision
- Medical

Description

The LZ4-00R208 Deep Red LED emitter generates 2.9W radiant flux or 15.9 μ mol/s nominal output at 6.6W power dissipation in an extremely small package. The LZ4-00R208 LED provides superior radiometric power in the wavelength range specifically required for plants' chlorophyll *a* absorption. With a 7.0mm x 7.0mm ultra-small footprint, this package provides exceptional radiant flux density. LED Engin's LZ4-00R208 LED offers ultimate design flexibility with individually addressable die. The patent-pending design has unparalleled thermal and optical performance. The high quality materials used in the package are chosen to optimize light output and minimize stresses which results in monumental reliability and lumen maintenance. The robust product design thrives in outdoor applications with high ambient temperatures and high humidity.

Part number options

Base part number

| Part number | Description |
|-----------------|--|
| LZ4-00R208-xxxx | LZ4 emitter |
| LZ4-40R208-xxxx | LZ4 emitter on Standard Star 1 channel MCPCB |

Bin kit option codes

| R2, Deep-Red (660nm) | | | |
|----------------------|--------------|-----------------|--|
| Kit number suffix | Min flux Bin | Color Bin Range | Description |
| 0000 | Q | F06 – F06 | full distribution flux; full distribution wavelength |

Notes:

1. Default bin kit option is -0000

Radiant Flux Bins

Table 1:

| Bin Code | Minimum Radiant Flux (Φ) @ $I_F = 700\text{mA}^{[1]}$ (W) | Maximum Radiant Flux (Φ) @ $I_F = 700\text{mA}^{[1]}$ (W) |
|----------|---|---|
| Q | 2.0 | 2.4 |
| R | 2.4 | 3.0 |
| S | 3.0 | 3.8 |

Notes for Table 1:

1. Radiant flux performance is measured at 10ms pulse, $T_C = 25^\circ\text{C}$. LED Engin maintains a tolerance of $\pm 10\%$ on flux measurements.

Peak Wavelength Bin

Table 2:

| Bin Code | Minimum Peak Wavelength (λ_p) @ $I_F = 700\text{mA}^{[1]}$ (nm) | Maximum Peak Wavelength (λ_p) @ $I_F = 700\text{mA}^{[1]}$ (nm) |
|----------|--|--|
| F06 | 655 | 670 |

Notes for Table 2:

1. Peak wavelength is measured at 10ms pulse, $T_C = 25^\circ\text{C}$. LED Engin maintains a tolerance of $\pm 2.0\text{nm}$ on peak wavelength measurements.

Forward Voltage Bins

Table 3:

| Bin Code | Minimum Forward Voltage (V_F) @ $I_F = 700\text{mA}^{[1,2]}$ (V) | Maximum Forward Voltage (V_F) @ $I_F = 700\text{mA}^{[1,2]}$ (V) |
|----------|---|---|
| 0 | 8.96 | 11.6 |

Notes for Table 3:

1. Forward Voltage is binned with all four LED dice connected in series.
2. Forward voltage is measured at 10ms pulse, $T_C = 25^\circ\text{C}$. LED Engin maintains a tolerance of $\pm 0.16\text{V}$ for forward voltage measurements for the four LEDs.

Absolute Maximum Ratings

Table 4:

| Parameter | Symbol | Value | Unit |
|--|-----------|--|------|
| DC Forward Current ^[1] | I_F | 1000 | mA |
| Peak Pulsed Forward Current ^[2] | I_{FP} | 1500 | mA |
| Reverse Voltage | V_R | See Note 3 | V |
| Storage Temperature | T_{stg} | -40 ~ +125 | °C |
| Junction Temperature | T_J | 125 | °C |
| Soldering Temperature ^[4] | T_{sol} | 260 | °C |
| Allowable Reflow Cycles | | 6 | |
| Autoclave Conditions ^[5] | | 121°C at 2 ATM, 100% RH for 168 hours | |

Notes for Table 4:

- Maximum DC forward current (per die) is determined by the overall thermal resistance and ambient temperature. Follow the curves in Figure 11 for current derating.
- Pulse forward current conditions: Pulse Width ≤ 10msec and Duty Cycle ≤ 10%.
- LEDs are not designed to be reverse biased.
- Solder conditions per JEDEC 020D. See Reflow Soldering Profile Figure 3.
- Autoclave Conditions per JEDEC JESD22-A102-C.
- LED Engin recommends taking reasonable precautions towards possible ESD damages and handling the LZ4-00R208 in an electrostatic protected area (EPA). An EPA may be adequately protected by ESD controls as outlined in ANSI/ESD S6.1.

Optical Characteristics @ $T_C = 25^\circ\text{C}$

Table 5:

| Parameter | Symbol | Typical | Unit |
|--|-----------------|------------|-------------------|
| Radiant Flux (@ $I_F = 700\text{mA}/1000\text{mA}$) ^[1] | Φ | 2.9/ 4.1 | W |
| PPF ^[2] 400-700nm (@ $I_F = 700\text{mA}/1000\text{mA}$) | | 15.9/ 22.2 | $\mu\text{mol/s}$ |
| Wall Plug Efficiency (@ $I_F = 350\text{mA}/700\text{mA}$) | η | 50/ 44 | % |
| Peak Wavelength | λ_p | 660 | nm |
| Viewing Angle ^[3] | $2\Theta_{1/2}$ | 100 | Degrees |
| Total Included Angle ^[4] | $\Theta_{0.9}$ | 120 | Degrees |

Notes for Table 5:

- Radiant flux typical value is for all four LED dice operating concurrently at rated current.
- PPF is Photosynthetic Photon Flux
- Viewing Angle is the off axis angle from emitter centerline where the radiant power is ½ of the peak value.
- Total Included Angle is the total angle that includes 90% of the total radiant flux.

Electrical Characteristics @ $T_C = 25^\circ\text{C}$

Table 6:

| Parameter | Symbol | Typical | Unit |
|---|-------------------------|---------|-------|
| Forward Voltage (@ $I_F = 700\text{mA}$) ^[1] | V_F | 9.4 | V |
| Forward Voltage (@ $I_F = 1000\text{mA}$) ^[1] | V_F | 10.3 | V |
| Temperature Coefficient of Forward Voltage | $\Delta V_F/\Delta T_J$ | -18.4 | mV/°C |
| Thermal Resistance (Junction to Case) | $R\Theta_{J-C}$ | 2.8 | °C/W |

Notes for Table 6:

- Forward Voltage typical value is for all four LED dice connected in series.

IPC/JEDEC Moisture Sensitivity Level

Table 7 - IPC/JEDEC J-STD-20 MSL Classification:

| Level | Floor Life | | Soak Requirements | | | |
|-------|------------|-------------------|-------------------|-----------------|------------|------------|
| | Time | Conditions | Standard | Accelerated | Time (hrs) | Conditions |
| 1 | Unlimited | ≤ 30°C/ 85% RH | 168 +5/-0 | 85°C/ 85% RH | n/a | n/a |

Notes for Table 7:

- The standard soak time is the sum of the default value of 24 hours for the semiconductor manufacturer's exposure time (MET) between bake and bag and the floor life of maximum time allowed out of the bag at the end user of distributor's facility.

Average Radiant Flux Maintenance Projections

Based on long-term WHTOL testing, LED Engin projects that the LZ Series will deliver, on average, 70% Radiant Flux Maintenance at 65,000 hours of operation at a forward current of 700 mA. This projection is based on constant current operation with junction temperature maintained at or below 110°C.

Mechanical Dimensions (mm)

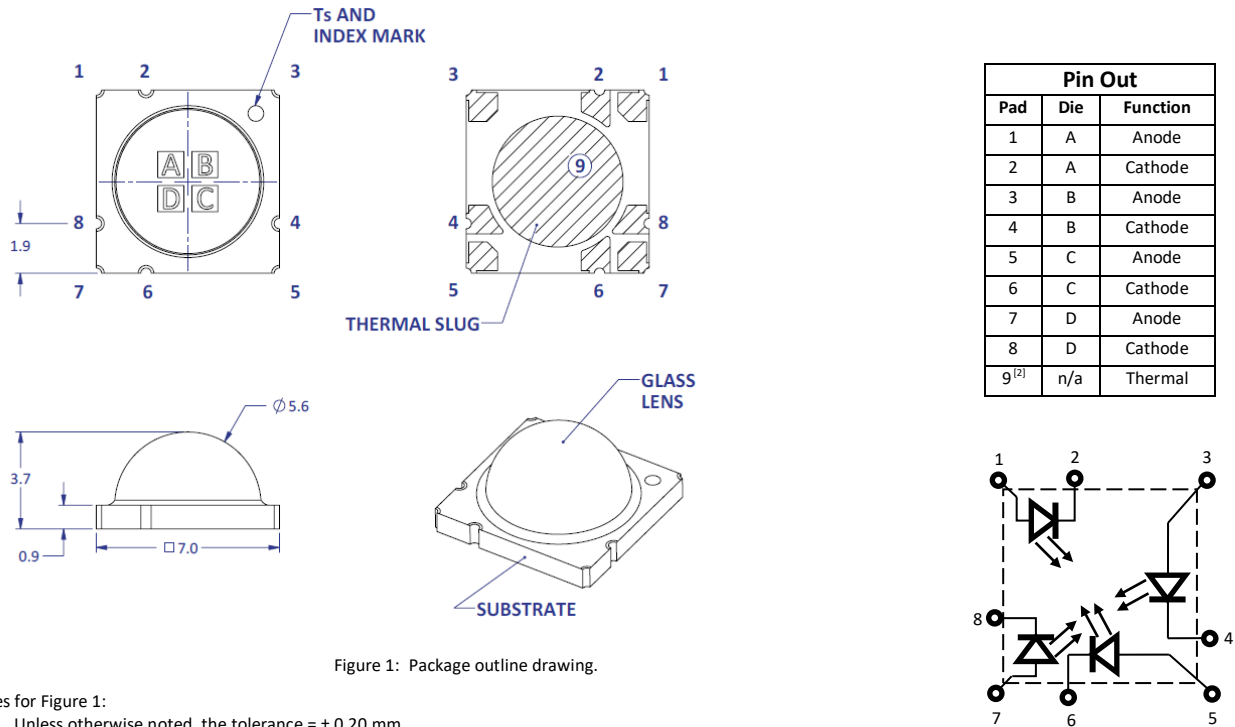

Figure 1: Package outline drawing.

Notes for Figure 1:

- Unless otherwise noted, the tolerance = ± 0.20 mm.
- Thermal contact, Pad 9, is electrically neutral.

Recommended Solder Pad Layout (mm)

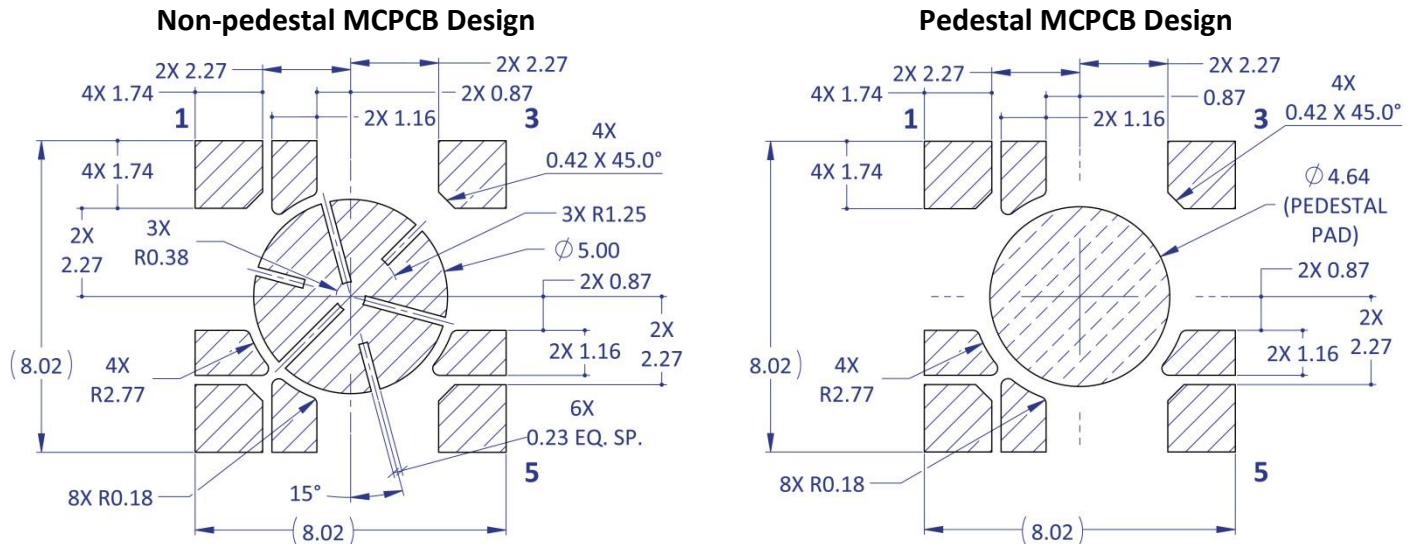

Figure 2a: Recommended solder pad layout for anode, cathode, and thermal pad for non-pedestal and pedestal design

Note for Figure 2a:

- Unless otherwise noted, the tolerance = ± 0.20 mm.
- Pedestal MCPCB allows the emitter thermal slug to be soldered directly to the metal core of the MCPCB. Such MCPCB eliminate the high thermal resistance dielectric layer that standard MCPCB technologies use in between the emitter thermal slug and the metal core of the MCPCB, thus lowering the overall system thermal resistance.
- LED Engin recommends x-ray sample monitoring for solder voids underneath the emitter thermal slug. The total area covered by solder voids should be less than 20% of the total emitter thermal slug area. Excessive solder voids will increase the emitter to MCPCB thermal resistance and may lead to higher failure rates due to thermal over stress.

Recommended Solder Mask Layout (mm)

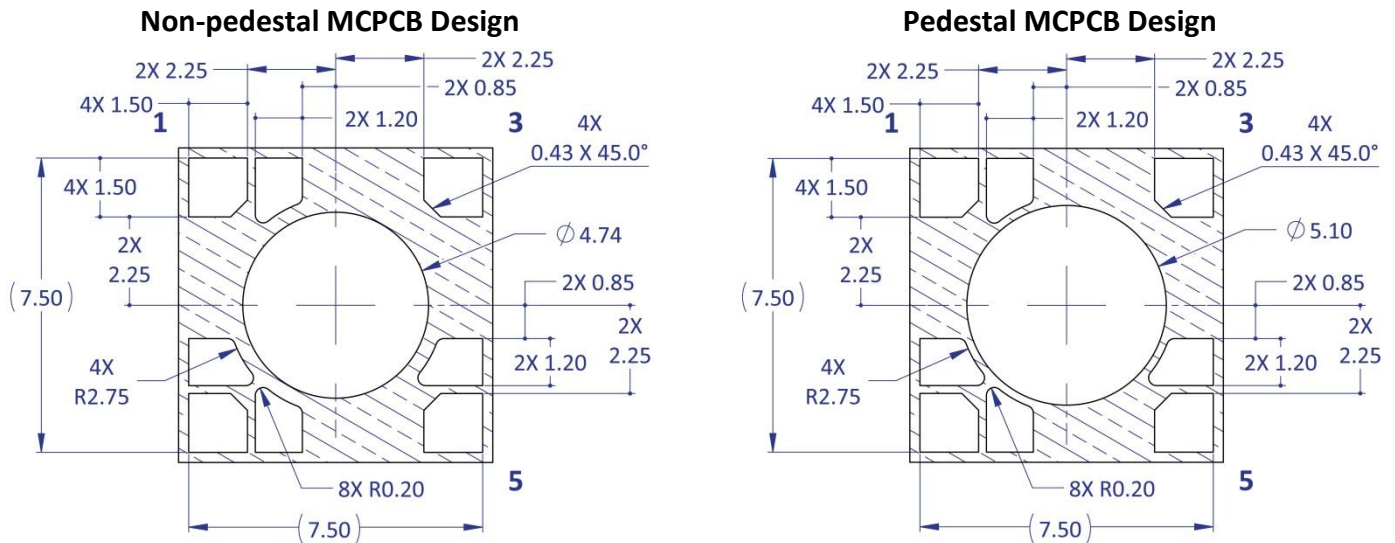

Figure 2b: Recommended solder mask opening for anode, cathode, and thermal pad for non-pedestal and pedestal design

Note for Figure 2b:

1. Unless otherwise noted, the tolerance = ± 0.20 mm.

Recommended 8 mil Stencil Apertures Layout (mm)

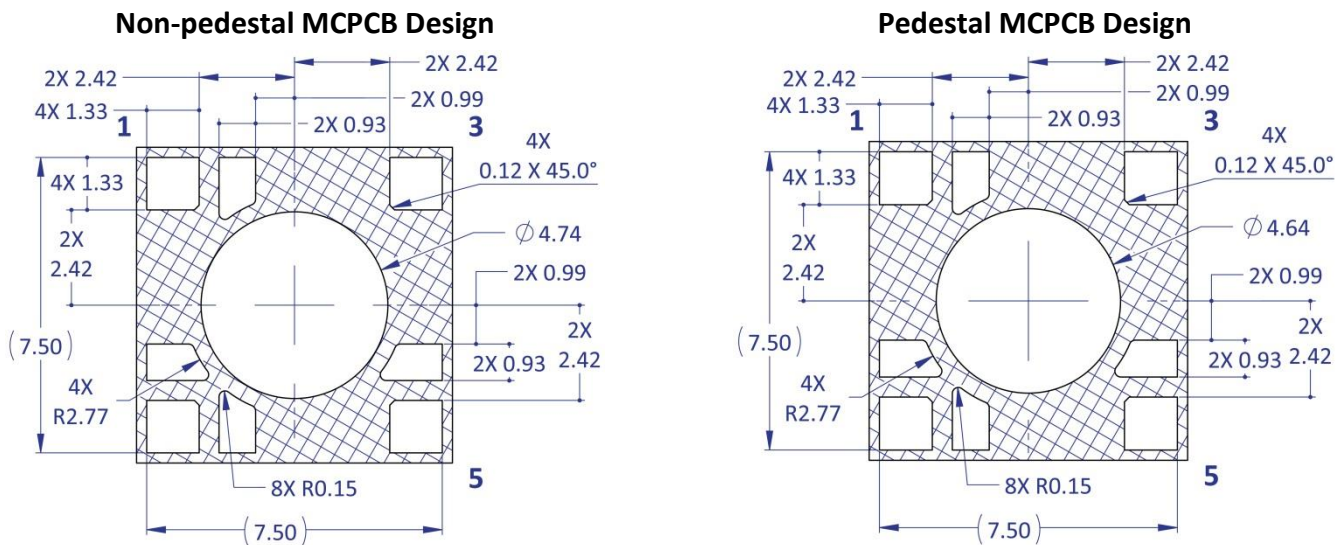

Figure 2c: Recommended 8mil stencil apertures for anode, cathode, and thermal pad for non-pedestal and pedestal design

Note for Figure 2c:

1. Unless otherwise noted, the tolerance = ± 0.20 mm.

Reflow Soldering Profile

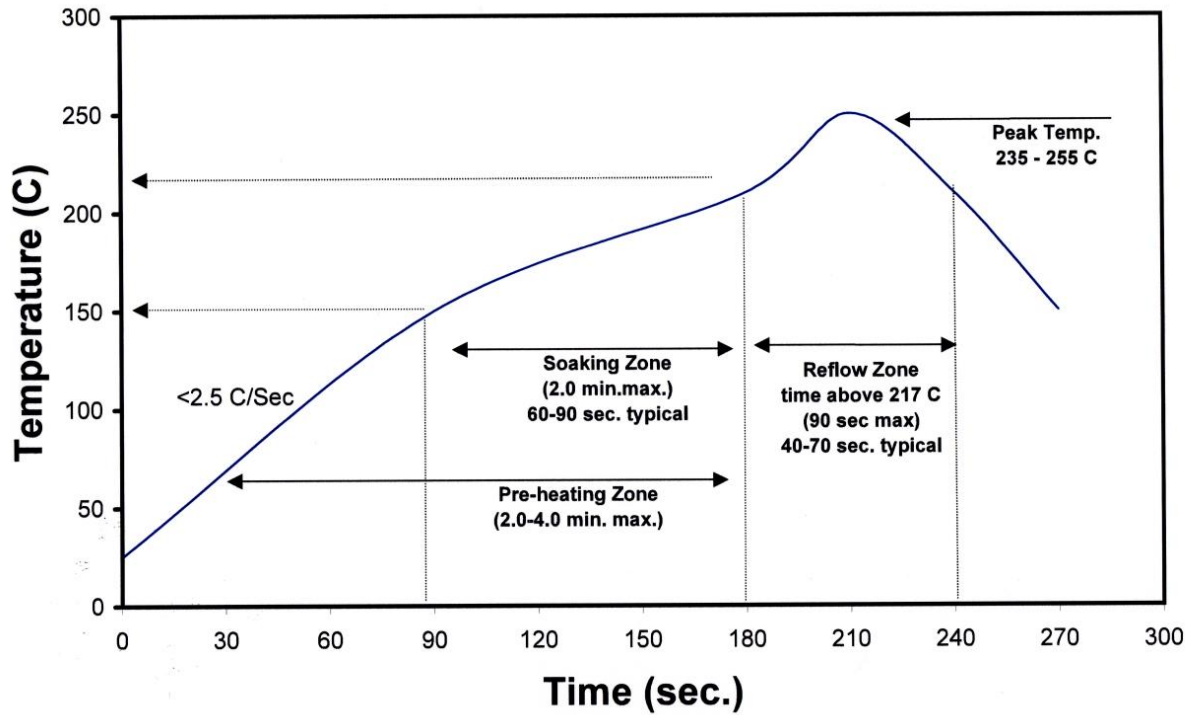

Figure 3: Reflow soldering profile for lead free soldering.

Typical Radiation Pattern

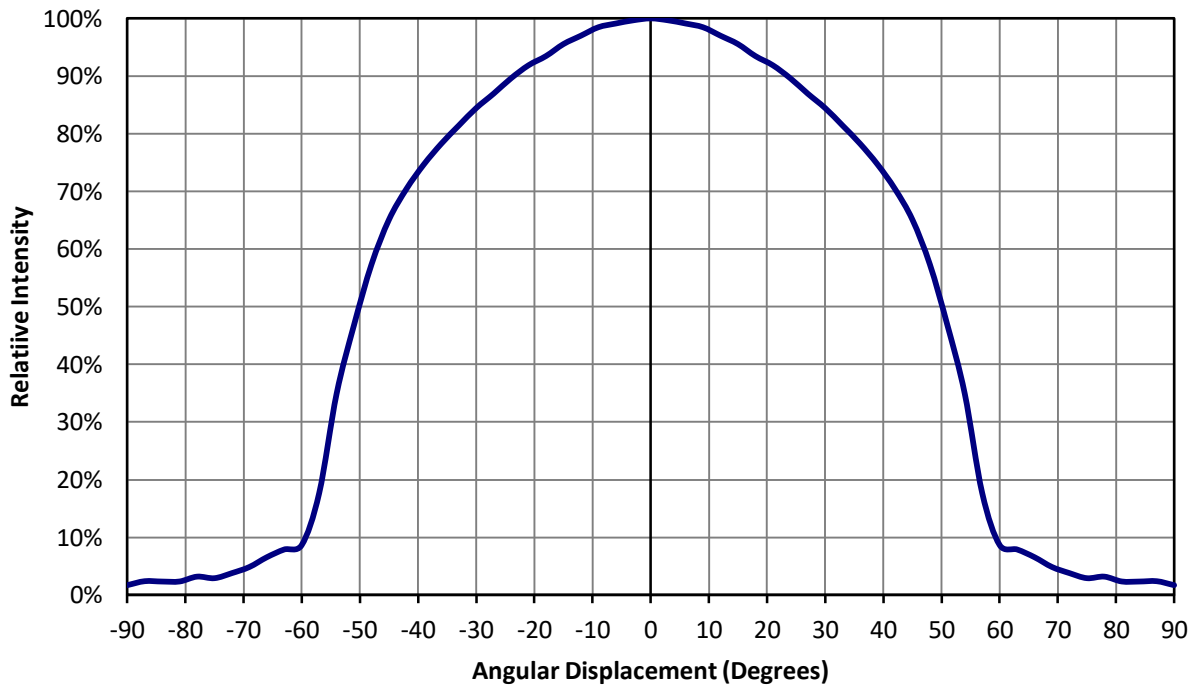

Figure 4: Typical representative spatial radiation pattern.

Typical Relative Spectral Power Distribution

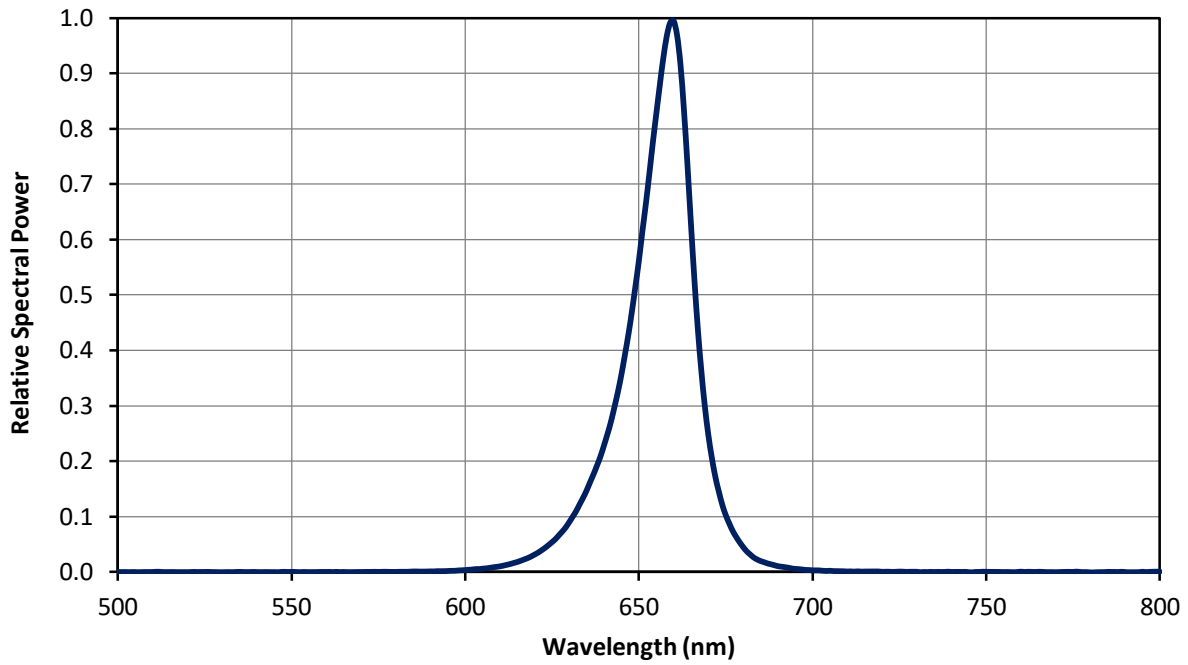

Figure 5: Relative spectral power vs. wavelength @ $T_c = 25^\circ\text{C}$.

Typical Forward Current Characteristics

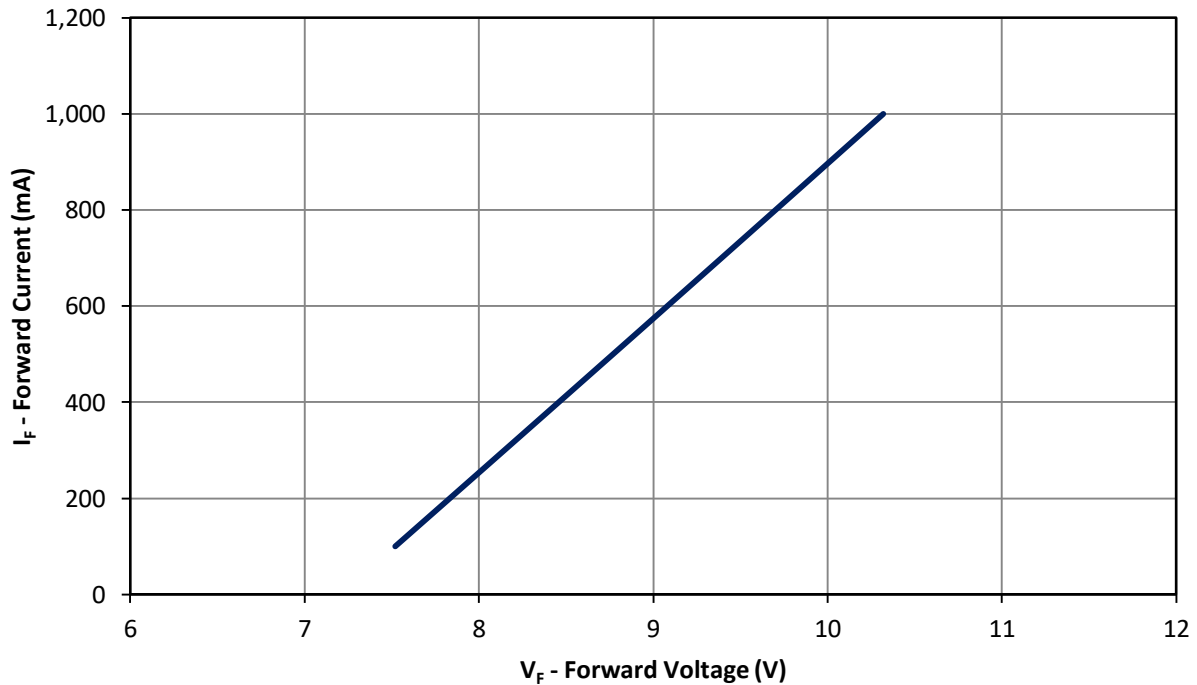

Figure 6: Typical forward current vs. forward voltage @ $T_c = 25^\circ\text{C}$.

Note for Figure 6:

1. Forward Voltage curve assumes that all four LED dice are connected in series.

Typical Normalized Radiant Flux over Current

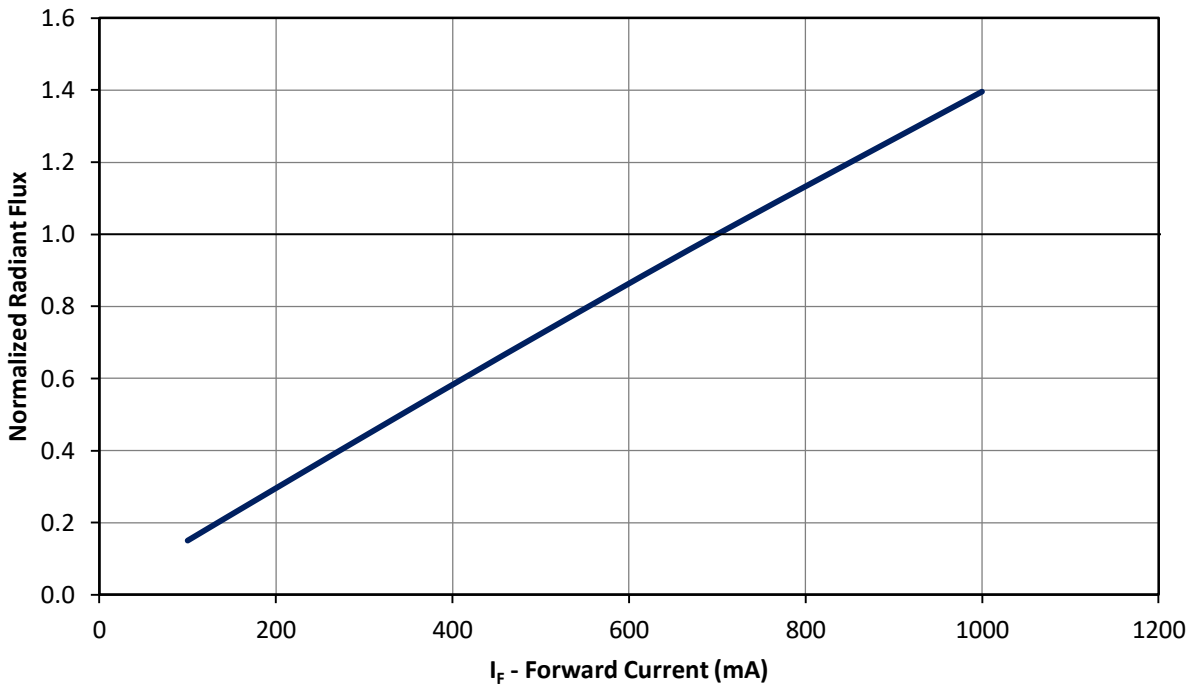

Figure 7: Typical normalized radiant flux vs. forward current @ $T_c = 25^\circ\text{C}$.

Typical Normalized Radiant Flux over Temperature

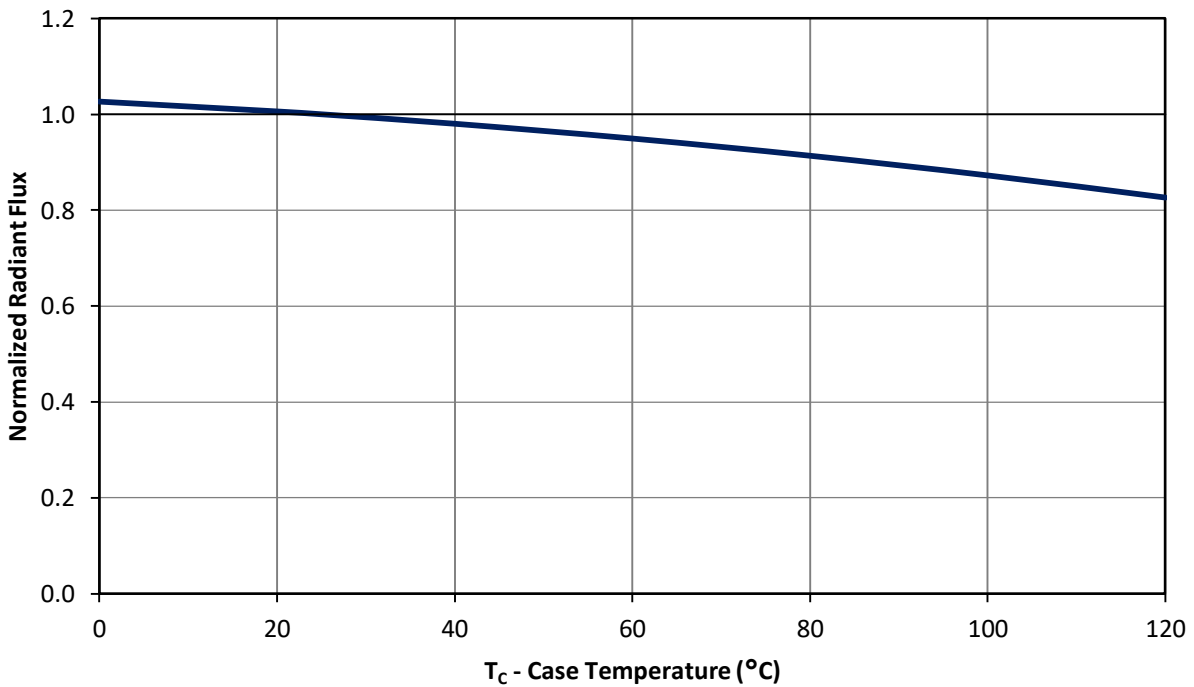

Figure 8: Typical normalized radiant flux vs. case temperature.

Typical Peak Wavelength Shift over Current

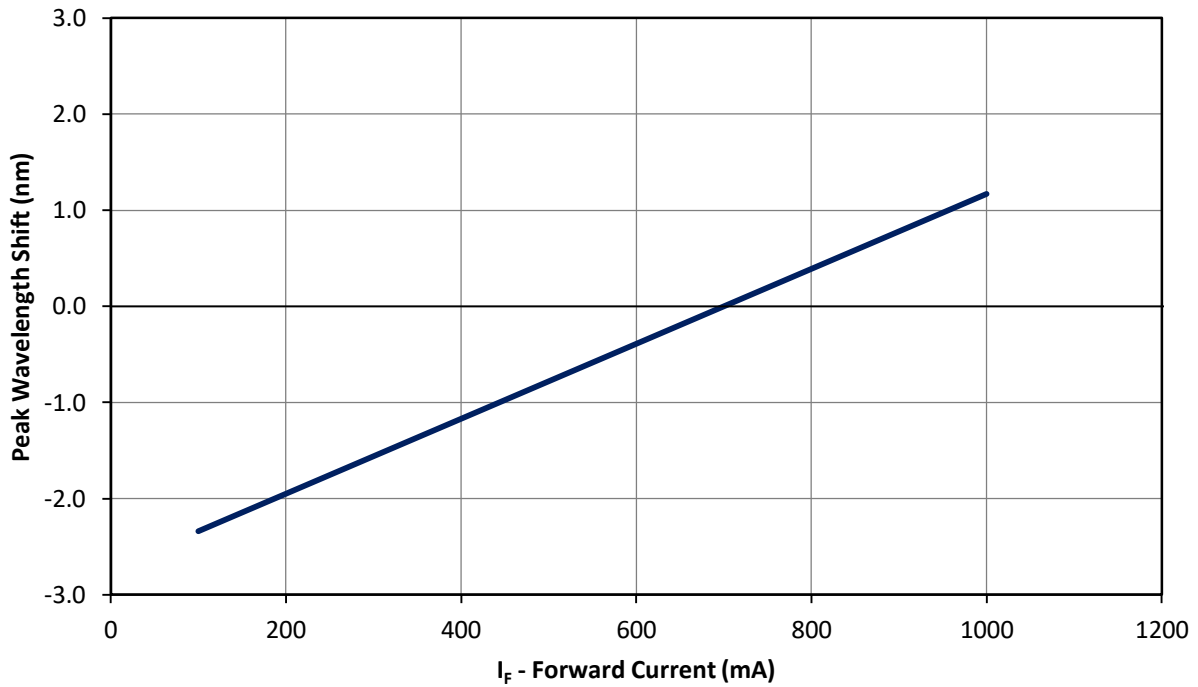

Figure 9: Typical peak wavelength shift vs. forward current @ $T_c = 25^\circ\text{C}$.

Typical Peak Wavelength Shift over Temperature

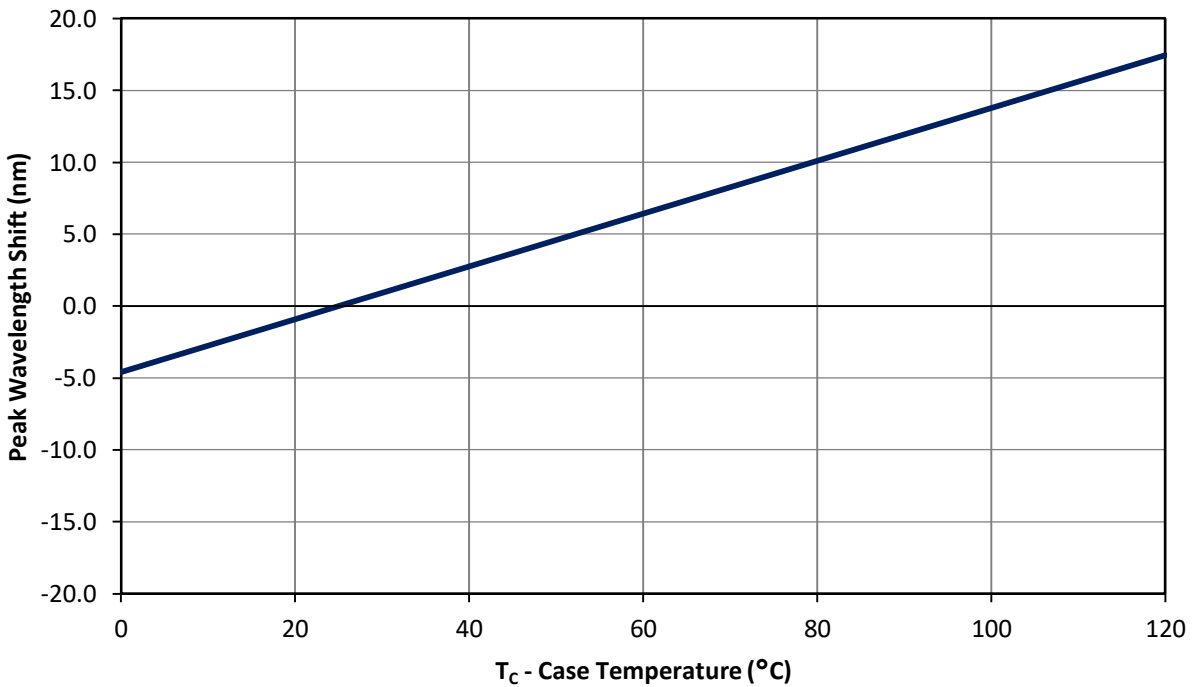

Figure 10: Typical peak wavelength shift vs. case temperature.

Current De-rating

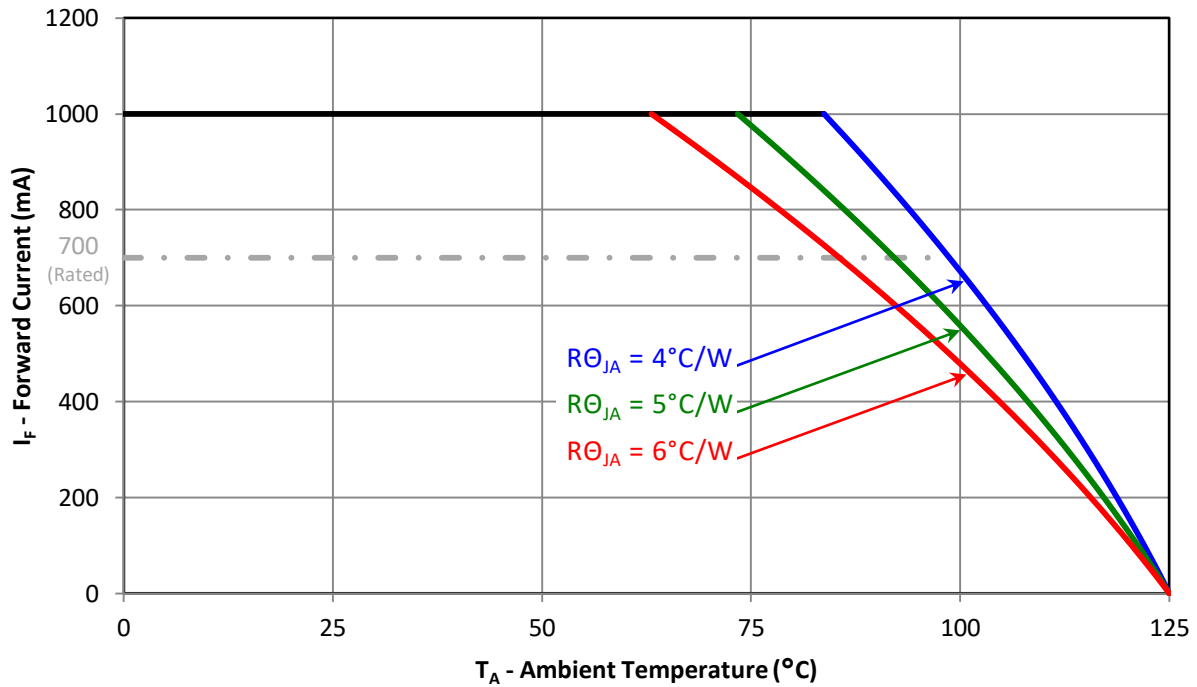

Figure 11: Maximum forward current vs. ambient temperature based on $T_{J(\text{MAX})} = 125^\circ\text{C}$.

Notes for Figure 11:

1. Maximum current assumes that all four LED dice are operating concurrently at the same current.
2. $R\theta_{JC}$ [Junction to Case Thermal Resistance] for the LZ4-00R208 is typically 2.8°C/W .
3. $R\theta_{JA}$ [Junction to Ambient Thermal Resistance] = $R\theta_{JC} + R\theta_{CA}$ [Case to Ambient Thermal Resistance].

Emitter Tape and Reel Specifications (mm)

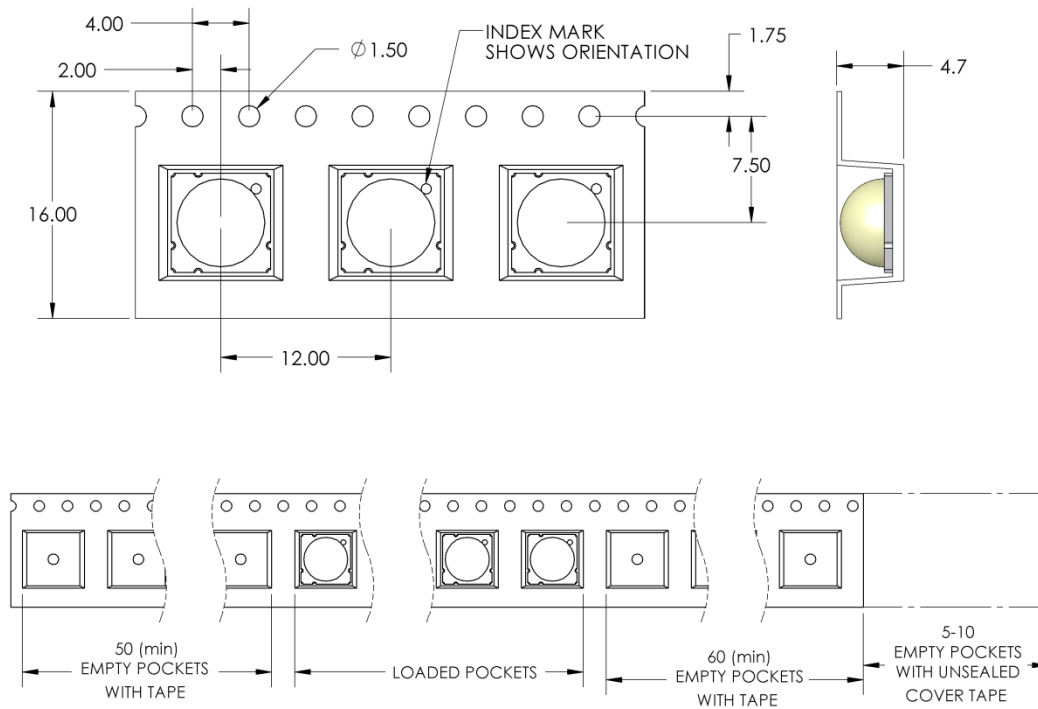

Figure 12: Emitter carrier tape specifications (mm).

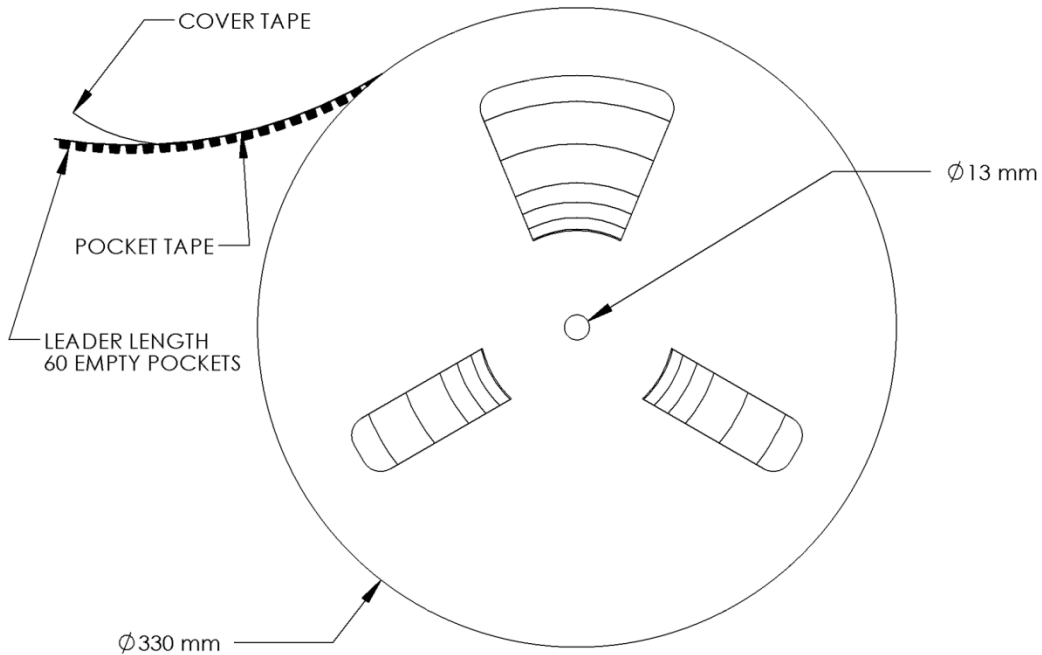

Figure 13: Emitter Reel specifications (mm).

Notes for Figure 13:

1. Small reel quantity: up to 250 emitters
2. Large reel quantity: 250-1200 emitters
3. Single flux bin and single wavelength per reel.

LZ4 MCPCB Family

| Part number | Type of MCPCB | Diameter (mm) | Emitter + MCPCB Thermal Resistance (°C/W) | Typical V _F (V) | Typical I _F (mA) |
|-------------|---------------|---------------|---|----------------------------|-----------------------------|
| LZ4-4xxxxx | 1-channel | 19.9 | 2.8 + 1.1 = 3.9 | 9.4 | 700 |

Mechanical Mounting of MCPCB

- MCPCB bending should be avoided as it will cause mechanical stress on the emitter, which could lead to substrate cracking and subsequently LED dies cracking.
- To avoid MCPCB bending:
 - Special attention needs to be paid to the flatness of the heat sink surface and the torque on the screws.
 - Care must be taken when securing the board to the heat sink. This can be done by tightening three M3 screws (or #4-40) in steps and not all the way through at once. Using fewer than three screws will increase the likelihood of board bending.
 - It is recommended to always use plastics washers in combinations with the three screws.
 - If non-taped holes are used with self-tapping screws, it is advised to back out the screws slightly after tightening (with controlled torque) and then re-tighten the screws again.

Thermal interface material

- To properly transfer heat from LED emitter to heat sink, a thermally conductive material is required when mounting the MCPCB on to the heat sink.
- There are several varieties of such material: thermal paste, thermal pads, phase change materials and thermal epoxies. An example of such material is Electrolube EHTC.
- It is critical to verify the material's thermal resistance to be sufficient for the selected emitter and its operating conditions.

Wire soldering

- To ease soldering wire to MCPCB process, it is advised to preheat the MCPCB on a hot plate of 125-150°C. Subsequently, apply the solder and additional heat from the solder iron will initiate a good solder reflow. It is recommended to use a solder iron of more than 60W.
- It is advised to use lead-free, no-clean solder. For example: SN-96.5 AG-3.0 CU 0.5 #58/275 from Kester (pn: 24-7068-7601)

LZ4-4xxxxx

1 channel, Standard Star MCPCB (1x4) Dimensions (mm)

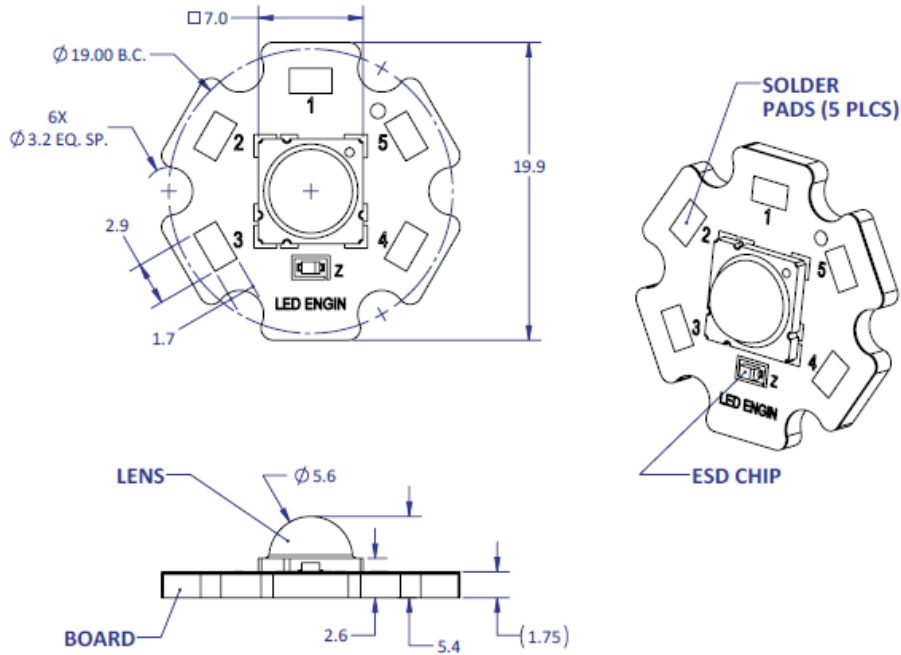

Notes:

- Unless otherwise noted, the tolerance = ± 0.2 mm.
- Slots in MCPCB are for M3 or #4-40 mounting screws.
- LED Engin recommends plastic washers to electrically insulate screws from solder pads and electrical traces.
- LED Engin recommends thermal interface material when attaching the MCPCB to a heatsink
- The thermal resistance of the MCPCB is: R θ C-B 1.1°C/W

Components used

MCPCB: HT04503 (Bergquist)
 ESD chips: BZX585-C30 (NXP, for 4 LED dies in series)

| Pad layout | | | |
|------------|-----------------|------------|----------------------|
| Ch. | MCPCB Pad | String/die | Function |
| 1 | 1, 2, 3 4, 5 | 1/ABCD | Cathode - Anode + |

About LED Engin

LED Engin, an OSRAM business based in California's Silicon Valley, develops, manufactures, and sells advanced LED emitters, optics and light engines to create uncompromised lighting experiences for a wide range of entertainment, architectural, general lighting and specialty applications. LuxiGen™ multi-die emitter and secondary lens combinations reliably deliver industry-leading flux density, upwards of 5000 quality lumens to a target, in a wide spectrum of colors including whites, tunable whites, multi-color and UV LEDs in a unique patented compact ceramic package. Our LuxiTune™ series of tunable white lighting modules leverage our LuxiGen emitters and lenses to deliver quality, control, freedom and high density tunable white light solutions for a broad range of new recessed and downlighting applications. The small size, yet remarkably powerful beam output and superior in-source color mixing, allows for a previously unobtainable freedom of design wherever high-flux density, directional light is required. LED Engin is committed to providing products that conserve natural resources and reduce greenhouse emissions; and reserves the right to make changes to improve performance without notice.

For more information, please contact LEDE-Sales@osram.com or +1 408 922-7200.

Компания «Океан Электроники» предлагает заключение долгосрочных отношений при поставках импортных электронных компонентов на взаимовыгодных условиях!

Наши преимущества:

- Поставка оригинальных импортных электронных компонентов напрямую с производств Америки, Европы и Азии, а так же с крупнейших складов мира;
- Широкая линейка поставок активных и пассивных импортных электронных компонентов (более 30 млн. наименований);
- Поставка сложных, дефицитных, либо снятых с производства позиций;
- Оперативные сроки поставки под заказ (от 5 рабочих дней);
- Экспресс доставка в любую точку России;
- Помощь Конструкторского Отдела и консультации квалифицированных инженеров;
- Техническая поддержка проекта, помощь в подборе аналогов, поставка прототипов;
- Поставка электронных компонентов под контролем ВП;
- Система менеджмента качества сертифицирована по Международному стандарту ISO 9001;
- При необходимости вся продукция военного и аэрокосмического назначения проходит испытания и сертификацию в лаборатории (по согласованию с заказчиком);
- Поставка специализированных компонентов военного и аэрокосмического уровня качества (Xilinx, Altera, Analog Devices, Intersil, Interpoint, Microsemi, Actel, Aeroflex, Peregrine, VPT, Syfer, Eurofarad, Texas Instruments, MS Kennedy, Miteq, Cobham, E2V, MA-COM, Hittite, Mini-Circuits, General Dynamics и др.);

Компания «Океан Электроники» является официальным дистрибьютором и эксклюзивным представителем в России одного из крупнейших производителей разъемов военного и аэрокосмического назначения «**JONHON**», а так же официальным дистрибьютором и эксклюзивным представителем в России производителя высокотехнологичных и надежных решений для передачи СВЧ сигналов «**FORSTAR**».



JONHON

«**JONHON**» (основан в 1970 г.)

Разъемы специального, военного и аэрокосмического назначения:

(Применяются в военной, авиационной, аэрокосмической, морской, железнодорожной, горно- и нефтедобывающей отраслях промышленности)

«**FORSTAR**» (основан в 1998 г.)

ВЧ соединители, коаксиальные кабели,
кабельные сборки и микроволновые компоненты:

(Применяются в телекоммуникациях гражданского и специального назначения, в средствах связи, РЛС, а так же военной, авиационной и аэрокосмической отраслях промышленности).



Телефон: 8 (812) 309-75-97 (многоканальный)

Факс: 8 (812) 320-03-32

Электронная почта: ocean@oceanchips.ru

Web: <http://oceanchips.ru/>

Адрес: 198099, г. Санкт-Петербург, ул. Калинина, д. 2, корп. 4, лит. А