

ASSR-5211

High Current, 1 Form A, Solid State Relay (MOSFET)

(600V/0.2A/16Ω)



Data Sheet



Lead (Pb) Free
RoHS 6 fully compliant

RoHS 6 fully compliant options available;
-xxxE denotes a lead-free product

Description

The ASSR-5211 is specifically designed for high current applications, commonly found in the industrial equipments. The relay is a solid-state replacement for single-pole, normally-open, (1 Form A) electromechanical relays.

The ASSR-5211 consists of an AlGaAs infrared light-emitting diode (LED) input stage optically coupled to a high-voltage output detector circuit. The detector consists of a high-speed photovoltaic diode array and driver circuitry to switch on/off two discrete high voltage MOSFETs. The relay turns on (contact closes) with a minimum input current of 3mA through the input LED. The relay turns off (contact opens) with an input voltage of 0.8V or less.

The ASSR-5211 connection A, as shown in the schematic, allows the relay to switch either ac or dc loads. The connection B, with its advantages of reduced on-resistance and higher output current, allows the relays to switch dc loads only.

The electrical and switching characteristics are specified over the temperature range of -40°C to +85°C.

Functional Diagram

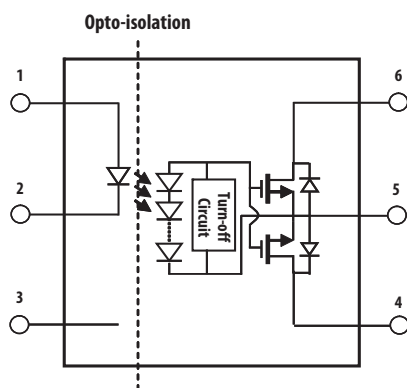

Truth Table

LED	Output
Off	Open
On	Close

Features

- Compact Solid-State Bi-directional Signal Switch
- Single Channel Normally-off Single-Pole-Single-Throw (SPST) Relay
- 600V Output Withstand Voltage
- 0.2A or 0.4A Current Rating
- Low Input Current: CMOS Compatibility
- Low On-Resistance:
2.5Ω Typical for DC-only, 10Ω Typical for AC/DC
- High Speed Switching:
0.7ms (Ton), 0.07ms (Toff) Typical @ I_F = 5mA
- High Transient Immunity: >1kV/μs
- High Input-to-Output Insulation Voltage (Safety and Regulatory Approvals Pending)
 - 3750 V_{RMS} for 1 min per UL1577
 - CSA Component Acceptance
 - *5000 V_{RMS}/1 Minute rating is for Option X21 only (Please consult your regional Avago representatives)

Applications

- Industrial Controls
- Factory Automation
- Data Acquisition
- Measuring Instrument
- Medical System
- Security System
- EMR / Reed Relay Replacement

CAUTION: It is advised that normal static precautions be taken in handling and assembly of this component to prevent damage and/or degradation which may be induced by ESD.

Ordering Table

ASSR-5211 is UL Recognized with 3750 V_{RMS} and 5000 V_{RMS} (option x21*) for 1 minute per UL1577 and is approved under CSA Components Acceptance Notice #5.

Part Number	Option	Package	Surface Mount	Gullwing	Tape & Reel	Quantity
	RoHS Compliant					
ASSR-5211	-001E	300mil DIP-6	X	X	X	50 units per tube
	-301E					1000 units per reel
	-501E					1000 units per reel

To order, choose a part number from the part number column and combine with the desired option from the option column to form an order entry.

Example 1:

ASSR-5211-501E to order product of 300mil DIP-6 Gull Wing Surface Mount package in Tape and Reel packaging and RoHS Compliant.

x21* - 'Please consult your regional Avago representatives'

Schematic

Connection A – AC/DC

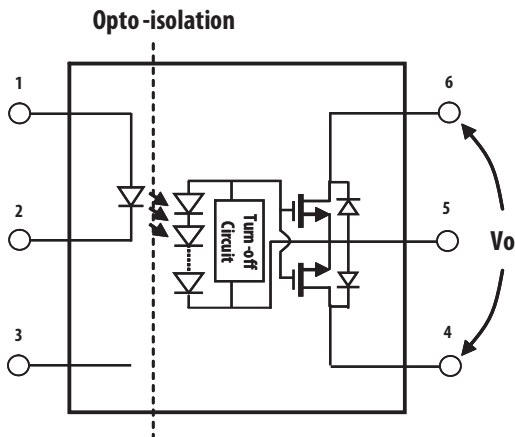

Equivalent
Relay
Diagram

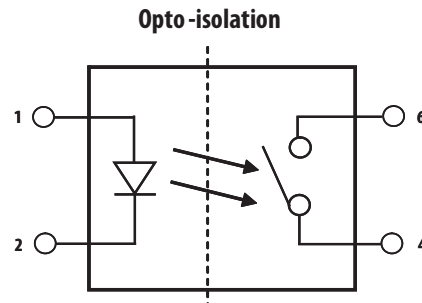

Connection B – DC Only

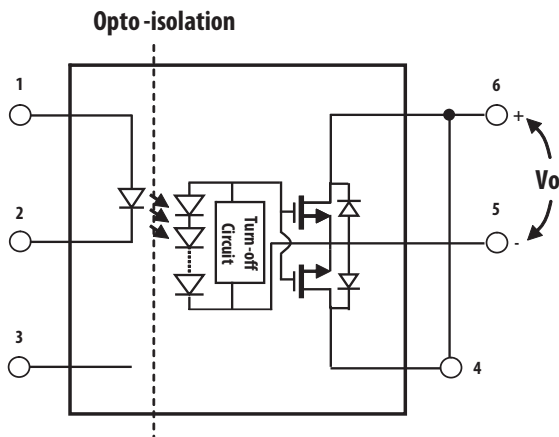

Equivalent
Relay
Diagram

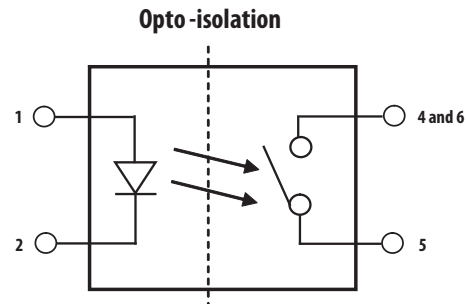

Package Outline Drawings

ASSR-5211 6-Pin DIP Package

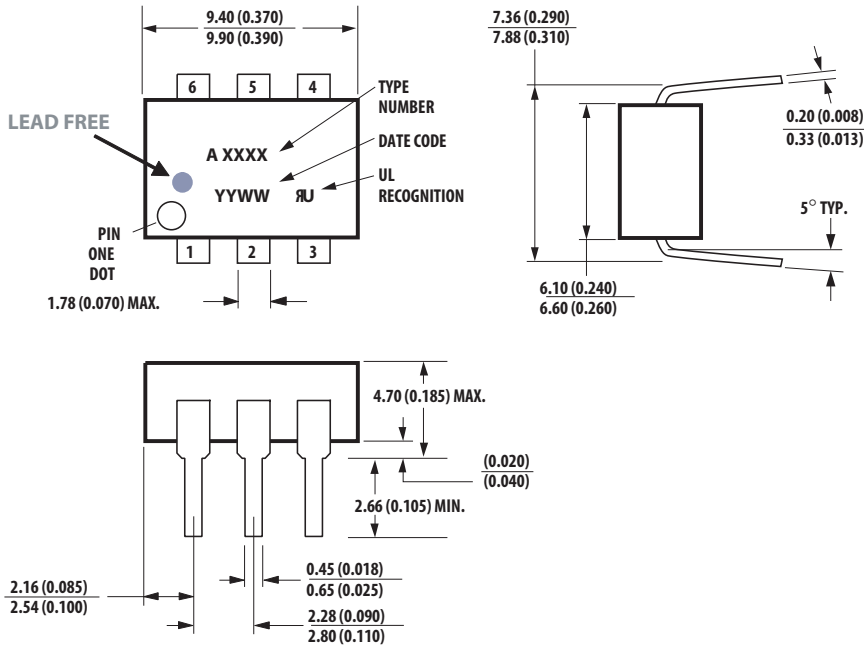

DIMENSIONS IN MILLIMETERS AND (INCHES).

ASSR-5211 6-Pin DIP Package with Gull Wing Surface Mount Option 300

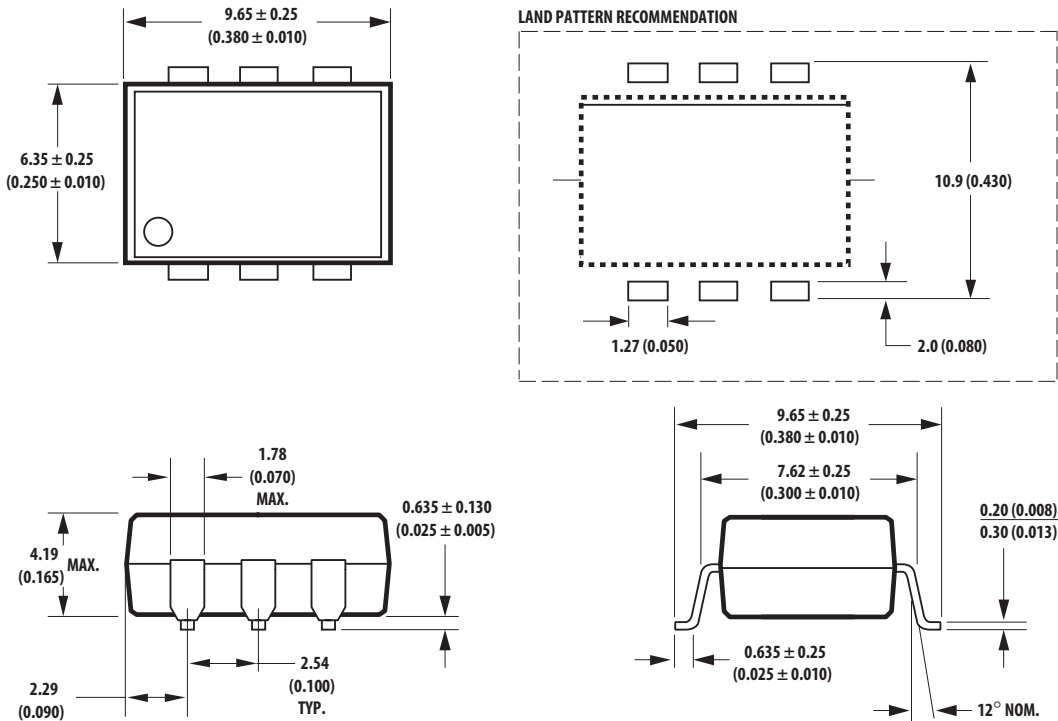

NOTE: FLOATING LEAD PROTRUSION IS 0.25 mm (10 mils) MAX.

Solder Reflow Temperature Profile

Recommended reflow condition as per JEDEC Standard, J-STD-020 (latest revision). Non-Halide Flux should be used.

Regulatory Information

The ASSR-5211 is approved by the following organizations:

UL

Approved under UL 1577, component recognition program up to $V_{ISO} = 3750 V_{RMS}$ and $5000 V_{RMS}$ (option x21).

CSA

Approved under CSA Component Acceptance Notice #5.

Insulation and Safety Related Specifications

Parameter	Symbol	ASSR-5211	Units	Conditions
Minimum External Air Gap (Clearance)	L(101)	7.1	mm	Measured from input terminals to output terminals, shortest distance through air.
Minimum External Tracking (Creepage)	L(102)	7.4	mm	Measured from input terminals to output terminals, shortest distance path along body.
Minimum Internal Plastic Gap (Internal Clearance)		0.08	mm	Through insulation distance conductor to conductor, usually the straight line distance thickness between the emitter and detector.
Tracking Resistance (Comparative Tracking Index)	CTI	175	V	DIN IEC 112/VDE 0303 Part 1
Isolation Group (DIN VDE0109)		IIIa		Material Group (DIN VDE 0109)

Absolute Maximum Ratings

Parameter	Symbol	Min.	Max.	Units	Note	
Storage Temperature	T_S	-55	125	°C		
Operating Temperature	T_A	-40	85	°C		
Junction Temperature	T_J		125	°C		
Lead Soldering Cycle	Temperature		260	°C		
	Time		10	sec		
Input Current	Average	I_F	25	mA		
	Surge		50	mA		
	Transient		1000	mA		
Reversed Input Voltage	V_R		5	V		
Input Power Dissipation	P_{IN}		40	mW		
Output Power Dissipation	Connection A	P_O	640	mW		
	Connection B		640	mW		
Average Output Current ($T_A=25^\circ\text{C}$, $T_C \leq 100^\circ\text{C}$)	Connection A	I_O	0.2	A		
	Connection B		0.4	A		
Output Voltage ($T_A=25^\circ\text{C}$)	Connection A	V_O	-600	600	V	1
	Connection B		0	600	V	
ESD Human Body Model: MIL-STD-883 Method 3015.7			4	kV		
Solder Reflow Temperature Profile		See Lead Free IR Profile				

Recommended Operating Conditions

Parameter	Symbol	Min.	Max.	Units	Note
Input Current (ON)	$I_{F(ON)}$	3	20	mA	
Input Voltage (OFF)	$V_{F(OFF)}$	0	0.8	V	
Operating Temperature	T_A	-40	+85	°C	

Package Characteristics

Unless otherwise specified, operating temperature $T_A = 25^\circ\text{C}$.

Parameter	Symbol	Min.	Typ.	Max.	Units	Conditions	Note
Input-Output Momentary Withstand Voltage	V_{ISO}	3750			V_{RMS}	RH \leq 50%, t = 1 min, $T_A = 25^\circ\text{C}$	3, 4
		5000				RH \leq 50%, t = 1 min, $T_A = 25^\circ\text{C}$, option x21	
Input-Output Resistance	R_{I-O}		10^{14}		Ω	$V_{I-O} = 500\text{ Vdc}$	3
Input-Output Capacitance	C_{I-O}		0.8		pF	$V_{I-O} = 0\text{ Vdc}$, f = 1MHz	3

Electrical Specifications (DC)

Over recommended operating $T_A = -40^{\circ}\text{C}$ to 85°C , $I_F = 5\text{mA}$ to 10mA , unless otherwise specified.

Parameter	Sym.	Min.	Typ.	Max.	Units	Conditions	Fig.	Note
Output Withstand Voltage	$ V_{O(OFF)} $	600	650		V	$V_F=0.8\text{V}$, $I_O=250\mu\text{A}$, $T_A=25^{\circ}\text{C}$		
		550			V	$V_F=0.8\text{V}$, $I_O=250\mu\text{A}$		
Output On-Resistance	Connection A	$R_{(ON)}$	10	16	Ω	$I_F=5\text{mA}$, $I_O=0.2\text{A}$, Pulse $\leq 30\text{ms}$, $T_A=25^{\circ}\text{C}$	3 10	- 6
	Connection B	$R_{(ON)}$	2.5	4	Ω	$I_F=5\text{mA}$, $I_O=0.4\text{A}$, Pulse $\leq 30\text{ms}$, $T_A=25^{\circ}\text{C}$	11	6
Output Leakage Current	$I_{O(OFF)}$	0.001	0.1		μA	$V_F=0.8\text{V}$, $V_O=600\text{V}$, $T_A=25^{\circ}\text{C}$	5	-
			1		μA	$V_F=0.8\text{V}$, $V_O=550\text{V}$	4	-
Output Off-Capacitance	$C_{(OFF)}$	500			pF	$V_F=0.8\text{V}$, $V_O=0\text{V}$, $f=1\text{MHz}$	6	-
Output Offset Voltage	$ V_{(OS)} $	1			μV	$I_F=5\text{mA}$, $I_O=0\text{mA}$		
Input Reverse Breakdown Voltage	V_R	5			V	$I_R=10\mu\text{A}$		
Input Forward Voltage	V_F	1.1	1.3	1.7	V	$I_F=5\text{mA}$	7,8	-

Switching Specifications (AC)

Over recommended operating $T_A = -40^{\circ}\text{C}$ to 85°C , $I_F = 5\text{mA}$ to 10mA , unless otherwise specified.

Parameter	Sym.	Min.	Typ.	Max.	Units	Conditions	Fig.	Note
Turn On Time	T_{ON}	0.7	2.5		ms	$I_F=5\text{mA}$, $I_O=0.2\text{A}$, $T_A=25^{\circ}\text{C}$	12,16	
			5.0		ms	$I_F=5\text{mA}$, $I_O=0.2\text{A}$	13,16	
		0.4	1.5		ms	$I_F=10\text{mA}$, $I_O=0.2\text{A}$, $T_A=25^{\circ}\text{C}$	12,16	
			3.0		ms	$I_F=10\text{mA}$, $I_O=0.2\text{A}$	13,16	
Turn Off Time	T_{OFF}	0.07	0.5		ms	$I_F=5\text{mA}$, $I_O=0.2\text{A}$, $T_A=25^{\circ}\text{C}$	14,16	
			1		ms	$I_F=5\text{mA}$, $I_O=0.2\text{A}$	15,16	
		0.06	0.2		ms	$I_F=10\text{mA}$, $I_O=0.2\text{A}$, $T_A=25^{\circ}\text{C}$	14,16	
			0.5		ms	$I_F=10\text{mA}$, $I_O=0.2\text{A}$	15,16	
Output Transient Rejection	dV_O/dt	1	7		kV/ μs	$\Delta V_O=600\text{V}$, $R_M \geq 1\text{M}\Omega$, $C_M=1000\text{pF}$, $T_A=25^{\circ}\text{C}$	17	5
Input-Output Transient Rejection	dV_{I-O}/dt	1	20		kV/ μs	$V_{DD}=5\text{V}$, $\Delta V_{I-O}=1000\text{V}$, $R_L=1\text{k}\Omega$, $C_L=25\text{pF}$, $T_A=25^{\circ}\text{C}$	18	5

Notes:

- For derating, refer to Figure 1 and 2.
- The voltage across the output terminal of the relay should not exceed this rated withstand voltage. Over-voltage protection circuits should be added in some applications to protect against over-voltage transients.
- Device is considered as a two terminal device: pins 1, 2, and 3 shorted together and pins 5, 6, and 7 shorted together.
- The Input-Output Momentary Withstand Voltage is a dielectric voltage rating that should not be interpreted as an input-output continuous voltage rating. For the continuous voltage rating refer to the IEC/EN/DIN EN 60747-5-2 Insulation Characteristics Table (if applicable), your equipment level safety specification, or Avago Application Note 1074, "Optocoupler Input-Output Endurance Voltage."
- During the pulsed $R_{(ON)}$ measurement (I_O duration $\leq 30\text{ms}$), ambient (T_A) and case temperature (T_C) are equal.
- For the transient rejection measurements, refer to Avago whitepaper, AV01-0610EN, "Solid State Relay Transient Immunity".

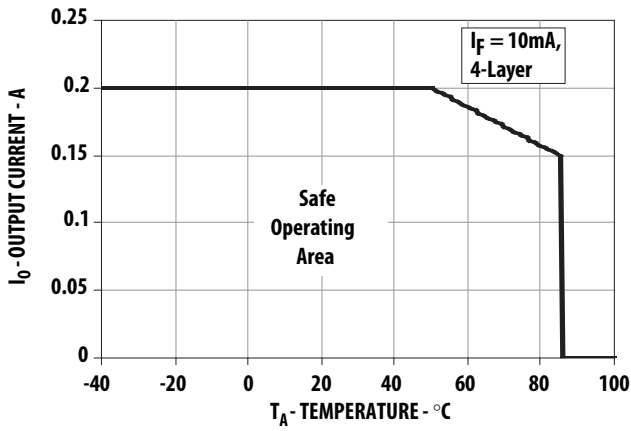

Figure 1. Maximum Output Current Rating vs Ambient Temperature (AC/DC Connection)

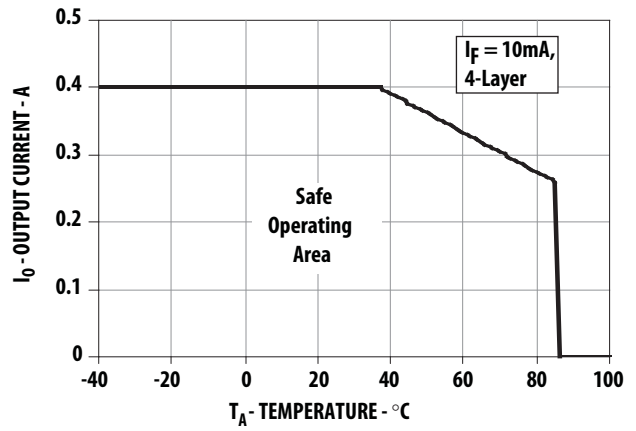

Figure 2. Maximum Output Current Rating vs Ambient Temperature (DC Connection)

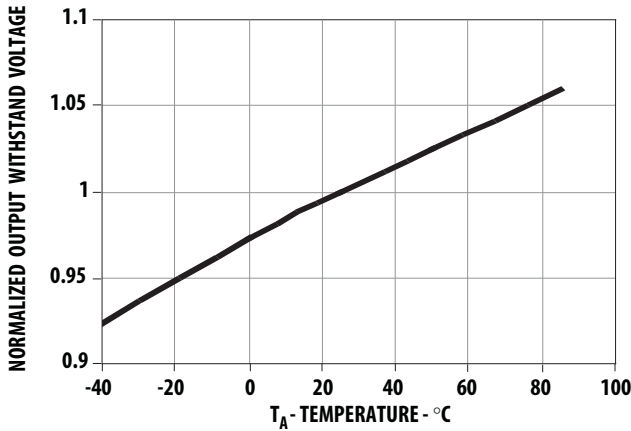

Figure 3. Normalized Typical Output Withstand Voltage vs Temperature

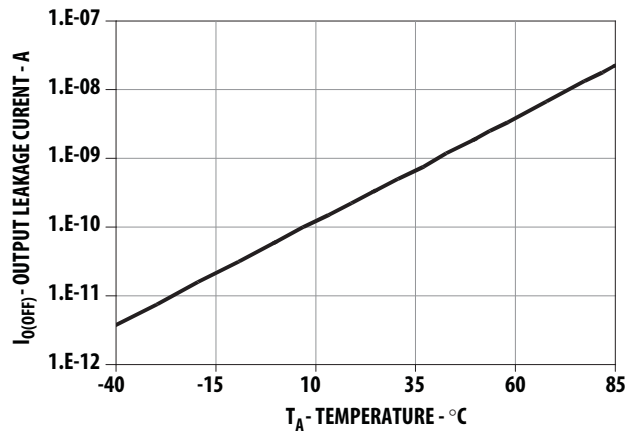

Figure 4. Typical Output Leakage Current vs Ambient Temperature

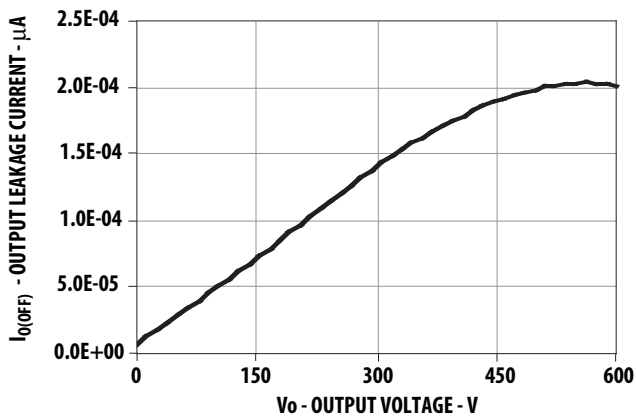

Figure 5. Typical Output Leakage Current vs Output Voltage

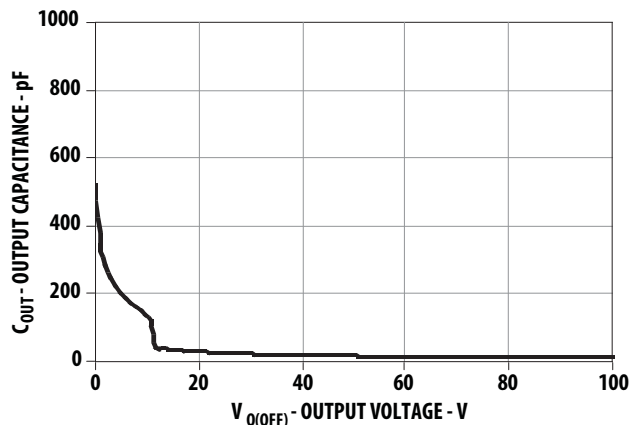

Figure 6. Typical Output Off-State Capacitance vs Output Voltage

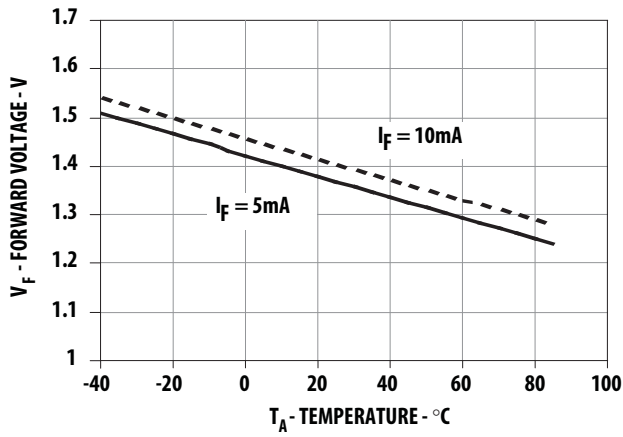

Figure 7. Typical Forward Voltage vs Ambient Temperature

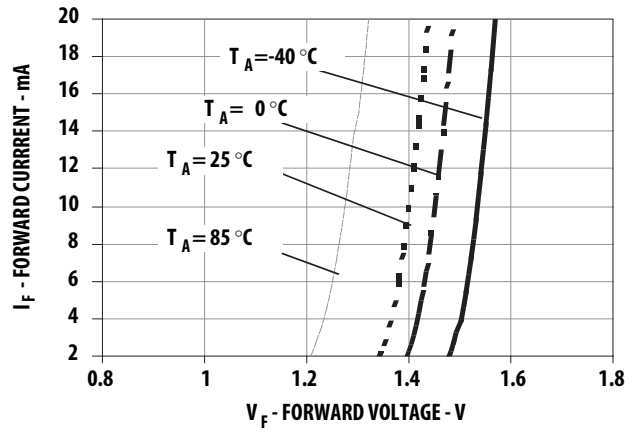

Figure 8. Typical Forward Current vs Forward Voltage

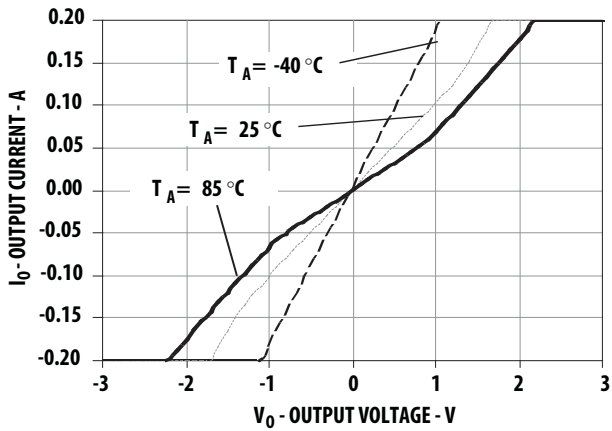

Figure 9. Typical Output Current vs Output Voltage

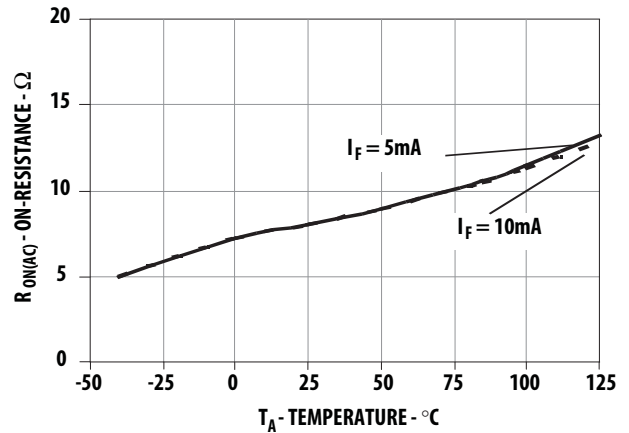

Figure 10. Typical On Resistance (AC/DC Connection) vs Temperature

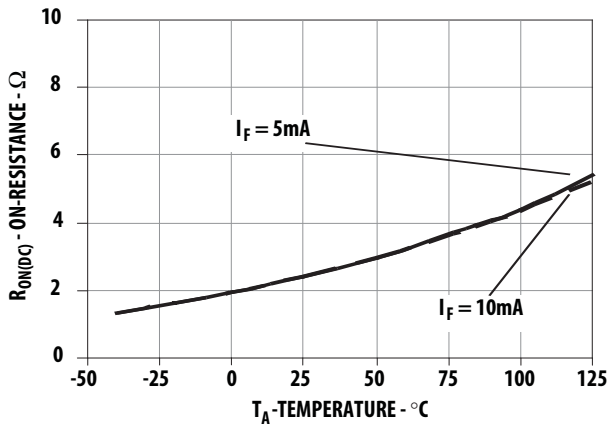

Figure 11. Typical On Resistance (DC Connection) vs Temperature

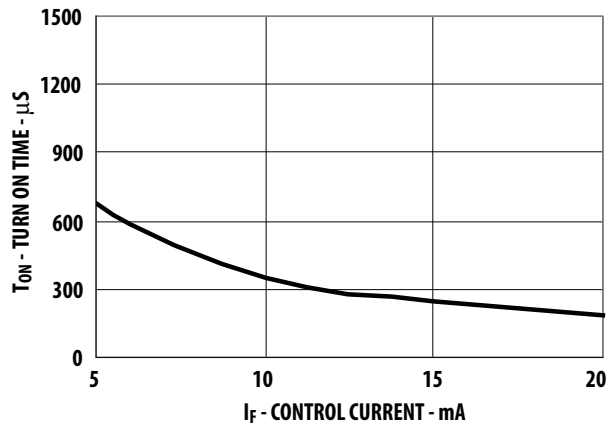

Figure 12. Typical Turn On Time vs Input Current

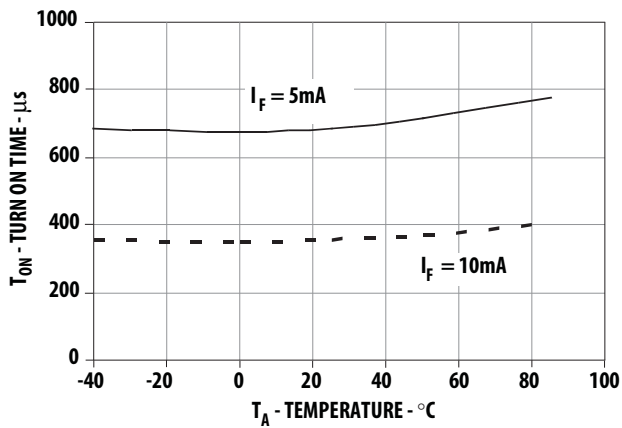

Figure 13. Typical Turn On Time vs Temperature

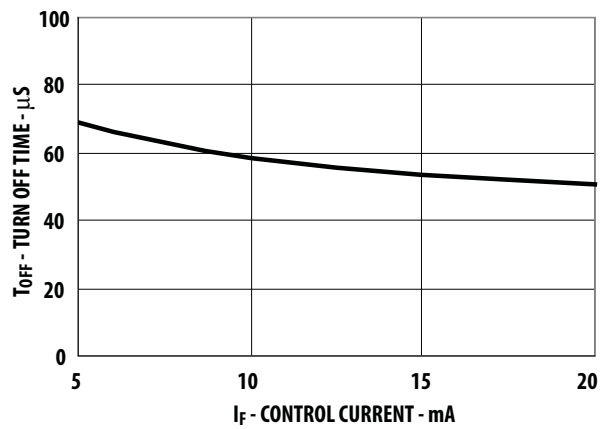

Figure 14. Typical Turn Off Time vs Input Current

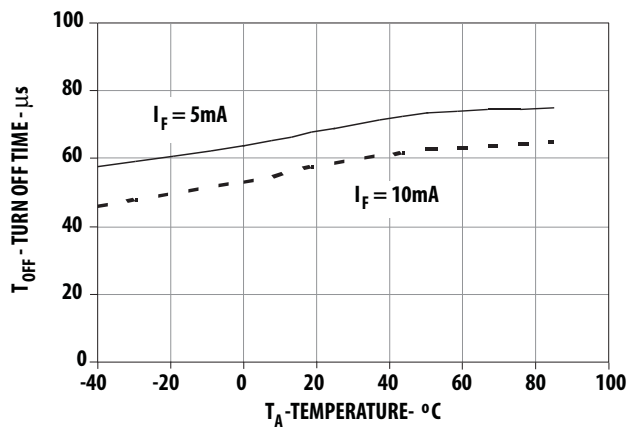

Figure 15. Typical Turn Off Time vs Temperature

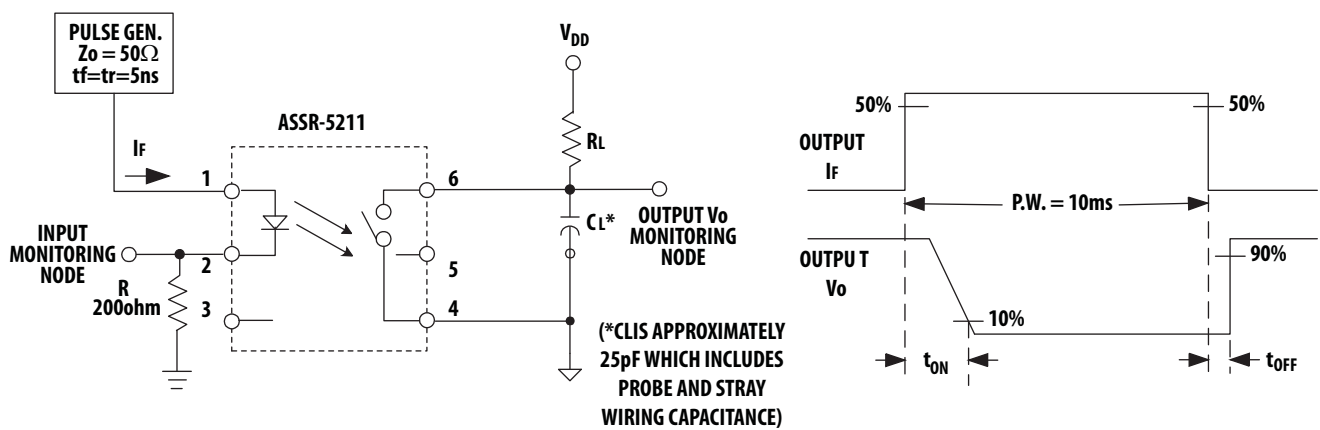
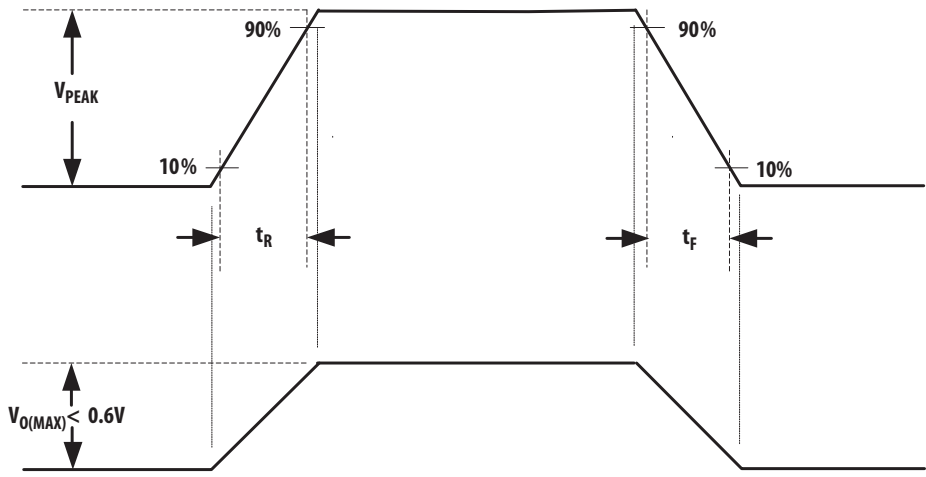
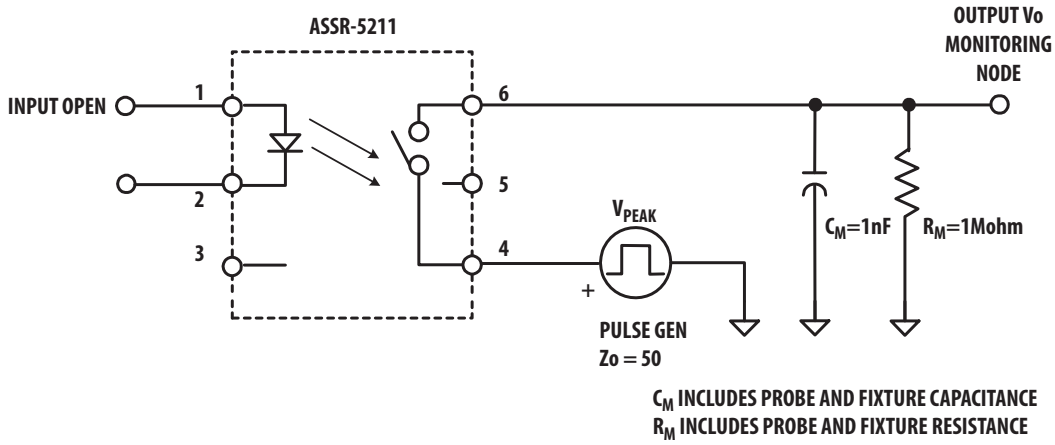

Figure 16 Switching Circuit for TON, TOFF



$$\frac{dV_o}{dt} = \frac{(0.8)V_{PEAK}}{t_R} \text{ OR } \frac{(0.8)V_{PEAK}}{t_F}$$

OVER SHOOT ON V_{PEAK} IS TO BE 10%

Figure 17 Test Circuit for Output Transient Immunity

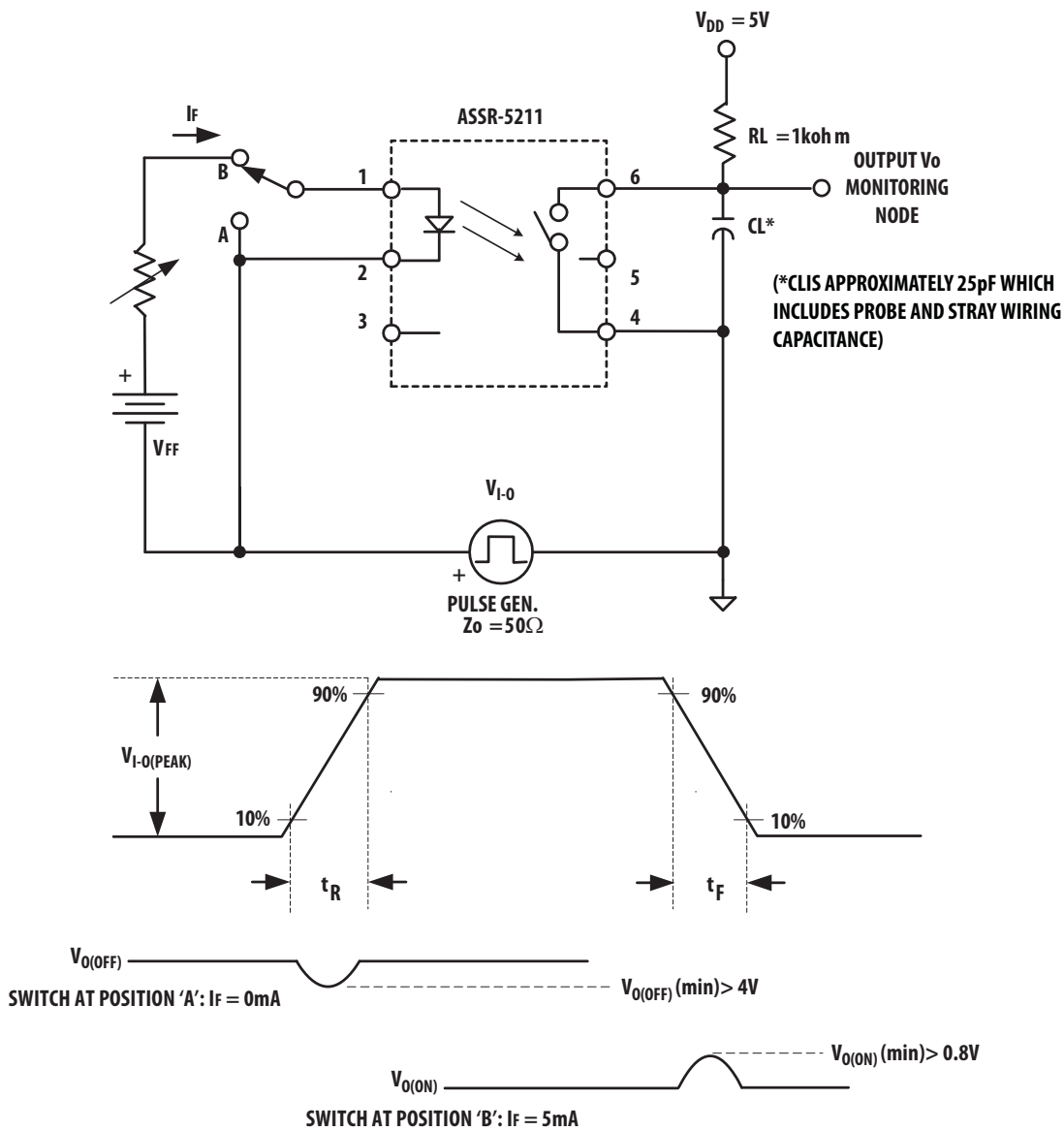

Figure 18 . Test Circuit for Input-Output Transient Immunity

For product information and a complete list of distributors, please go to our web site: www.avagotech.com

Avago, Avago Technologies, and the A logo are trademarks of Avago Technologies in the United States and other countries. Data subject to change. Copyright © 2005-2012 Avago Technologies. All rights reserved. AV02-0152EN - March 19, 2012



Компания «Океан Электроники» предлагает заключение долгосрочных отношений при поставках импортных электронных компонентов на взаимовыгодных условиях!

Наши преимущества:

- Поставка оригинальных импортных электронных компонентов напрямую с производств Америки, Европы и Азии, а так же с крупнейших складов мира;
- Широкая линейка поставок активных и пассивных импортных электронных компонентов (более 30 млн. наименований);
- Поставка сложных, дефицитных, либо снятых с производства позиций;
- Оперативные сроки поставки под заказ (от 5 рабочих дней);
- Экспресс доставка в любую точку России;
- Помощь Конструкторского Отдела и консультации квалифицированных инженеров;
- Техническая поддержка проекта, помощь в подборе аналогов, поставка прототипов;
- Поставка электронных компонентов под контролем ВП;
- Система менеджмента качества сертифицирована по Международному стандарту ISO 9001;
- При необходимости вся продукция военного и аэрокосмического назначения проходит испытания и сертификацию в лаборатории (по согласованию с заказчиком);
- Поставка специализированных компонентов военного и аэрокосмического уровня качества (Xilinx, Altera, Analog Devices, Intersil, Interpoint, Microsemi, Actel, Aeroflex, Peregrine, VPT, Syfer, Eurofarad, Texas Instruments, MS Kennedy, Miteq, Cobham, E2V, MA-COM, Hittite, Mini-Circuits, General Dynamics и др.);

Компания «Океан Электроники» является официальным дистрибьютором и эксклюзивным представителем в России одного из крупнейших производителей разъемов военного и аэрокосмического назначения «**JONHON**», а так же официальным дистрибьютором и эксклюзивным представителем в России производителя высокотехнологичных и надежных решений для передачи СВЧ сигналов «**FORSTAR**».



JONHON

«**JONHON**» (основан в 1970 г.)

Разъемы специального, военного и аэрокосмического назначения:

(Применяются в военной, авиационной, аэрокосмической, морской, железнодорожной, горно- и нефтедобывающей отраслях промышленности)

«**FORSTAR**» (основан в 1998 г.)

ВЧ соединители, коаксиальные кабели, кабельные сборки и микроволновые компоненты:

(Применяются в телекоммуникациях гражданского и специального назначения, в средствах связи, РЛС, а так же военной, авиационной и аэрокосмической отраслях промышленности).



Телефон: 8 (812) 309-75-97 (многоканальный)

Факс: 8 (812) 320-03-32

Электронная почта: ocean@oceanchips.ru

Web: <http://oceanchips.ru/>

Адрес: 198099, г. Санкт-Петербург, ул. Калинина, д. 2, корп. 4, лит. А