

Digital Amplifier Ultrasonic Sensor

E4C-UDA

CSM_E4C-UDA_DS_E_12_2

Compact, Cylindrical Reflective Ultrasonic Sensor with Easy Setting

- Stable operation for a variety of objects regardless of color, transparency, or material (metallic or non-metallic).
- Compact M18-sized cylindrical Head.
Product lineup includes Side-view Heads.
- Check the sensing object distance and sensing position (i.e., threshold) on the digital display.
- Easily make settings for workpiece presence/absence and elimination of background influence by using teaching.
- Amplifiers include models with analog outputs.



 Be sure to read *Safety precautions* on page 4.

Ordering Information

Sensor

Sensor Heads (Refer to Dimensions on page 5.)

Shape	Model	Measurement range	Model
M18	Straight	60 to 275 mm	E4C-DS30
	Side view		E4C-DS30L
	Straight	85 to 735 mm	E4C-DS80
	Side view		E4C-DS80L
	Straight	110 to 910 mm	E4C-DS100

Amplifiers (Refer to Dimensions on page 5.)

Shape	Power supply	Output specifications	Model
	DC	NPN output	E4C-UDA11
			E4C-UDA11AN
		PNP output	E4C-UDA41
			E4C-UDA41AN

Accessories (Order Separately)

Mounting Bracket (Refer to E39-L, E39-S, and E39-R.)

A Mounting Bracket is not provided with the Amplifier Unit. Order a Mounting Bracket separately if required.

Appearance	Model	Quantity
	E39-L143	1

End Plate (Refer to PFP-□.)

An End Plate is not provided with the Amplifier Unit. Order an End Plate separately if required.

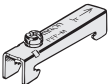
Appearance	Model	Quantity
	PFP-M	1

Ratings and Specifications

Sensor Heads

Item	Model	E4C-DS30	E4C-DS30L	E4C-DS80	E4C-DS80L	E4C-DS100
Measurement range		60 to 275 mm		85 to 735 mm		110 to 910 mm
Standard sensing object		100 × 100 mm SUS flat plate				
Near distance dead band		0 to 50 mm		0 to 70 mm		0 to 90 mm
Ultrasonic oscillation frequency		Approx. 390 kHz		Approx. 255 kHz		
Response speed *		30 ms		100 ms		125 ms
Ambient temperature range		Operating: -25 to +70°C, Storage: -40 to +85°C (with no icing or condensation)				
Ambient humidity range		Operating and storage: 35% to 85% (with no condensation)				
Insulation resistance		50 MΩ min. (at 500 VDC)				
Dielectric strength		1,000 VAC, 50/60 Hz for 1 min				
Vibration resistance		10 to 55 Hz, 1.5-mm double amplitude, 2 hours each in X, Y, and Z directions				
Shock resistance		500 m/s ² , 3 times each in X, Y and Z directions				
Enclosure rating		IP65				
Indicator		(Yellow) Lit: Sensor within sensing range (Green) Lit: Power indicator				(Yellow) Lit: Sensor within sensing range
Weight		Approx. 150 g				Approx. 170 g
Materials		Case: Nickel-plated brass, Oscillator surface: Glass epoxy resin and polyurethane				
Accessories		Instruction Manual, XS2F-D523-D80-A (Cable length: 2 m), XN2A-1430				

* This value is the average number of operations set to 256.

Amplifiers

Item	Model Type	E4C-UDA11	E4C-UDA41	E4C-UDA11AN	E4C-UDA41AN
		Twin Output Models		Analog Output Models	
Output configuration		NPN output	PNP output	NPN output	PNP output
Connection method		Pre-wired			
Supply voltage		12 to 24 VDC ±10%, ripple 10% max.			
Current consumption		80 mA max.			
Control output		NPN open collector (26.4 VDC max.), Load current: 50 mA max., Residual voltage: 1 V max.			
Timer		OFF/OFF-delay/ON-delay/one-shot			
Timer time		1 ms to 5 s			
Analog output	Connected load	---		Voltage output (1 to 5 VDC)	
	Output form	---		10 kΩ min.	
	Resolution	---		1.0% F.S.	
	Temperature characteristics	---		0.3% F.S./°C	
	Repeat accuracy	---		2.0% F.S. *	
	Linearity	---		Within ±2% F.S.	
Protective circuit		Power supply reverse polarity protection, output short-circuit protection			
Ambient temperature range		Operating: -25 to +55°C, Storage: -30 to +70°C (with no icing or condensation)			
Ambient humidity range		Operating and storage: 35% to 85% (with no condensation)			
Insulation resistance		20 MΩ min. (at 500 VDC)			
Dielectric strength		1,000 VAC, 50/60 Hz for 1 min			
Vibration resistance		10 to 55 Hz, 1.5-mm double amplitude, 2 hours each in X, Y, and Z directions			
Shock resistance		500 m/s ² , 3 times each in X, Y and Z directions			
Enclosure rating		IP 50			
Materials		Case: PBT (polybutylene terephthalate), Cover: Polycarbonate			
Weight (packed state)		Approx. 100 g			
Accessories		Instruction Manual			

* Value one hour after the product is turned ON. External disturbances, however, sometimes cause minute outputs.

Engineering Data (Reference Values)

Operating Range

E4C-DS30(L)

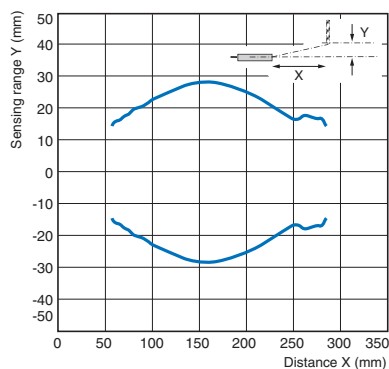

E4C-DS80(L)

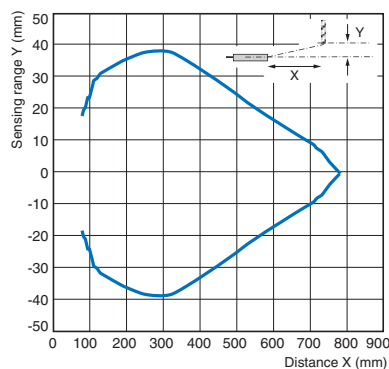

E4C-DS100

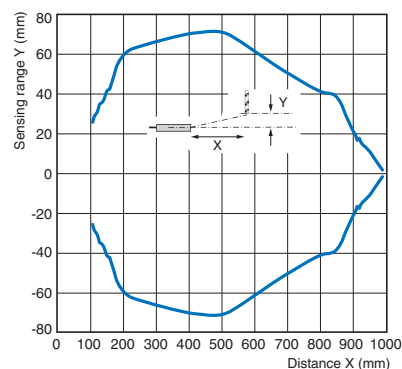

I/O Circuit Diagrams

E4C-UDA11 (NPN)

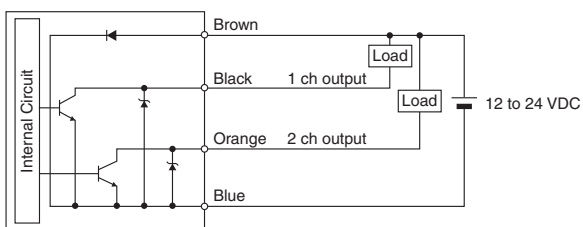

E4C-UDA41 (PNP)

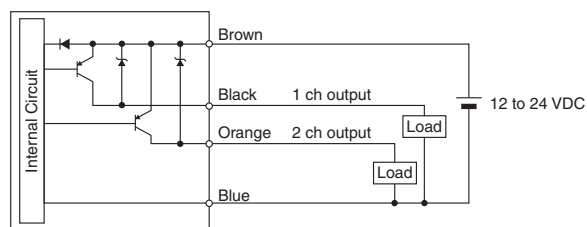

E4C-UDA11AN (NPN)

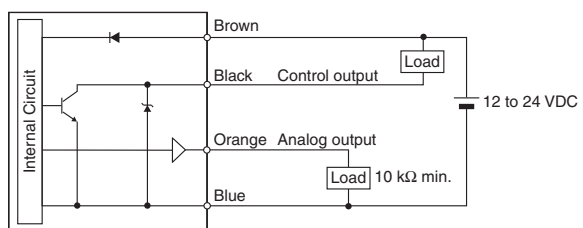

E4C-UDA41AN (PNP)

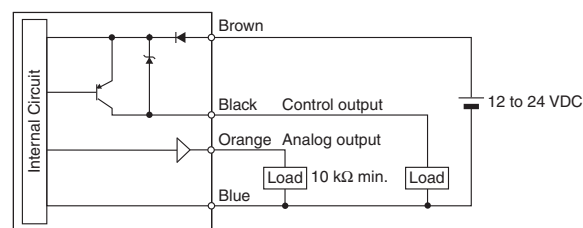

Safety precautions

Refer to *Warranty and Limitations of Liability*.

WARNING

This product is not designed or rated for ensuring safety of persons either directly or indirectly. Do not use it for such purposes.



Precautions for Correct Use

Do not use the product in atmospheres or environments that exceed product ratings.

- Separate the Sensor wiring from power supply and high-voltage lines. If Sensor wiring is placed together with or in the same duct as power supply or high-voltage lines, inductance may cause malfunction or damage to the Sensor.
- The extended cable length must be no more than 10 m. To extend the cable length, use 0.3 mm² cable.
- Detection will be possible 200 ms or longer after the power supply is turned ON. If separate power supplies are used for the load and the Sensor, turn ON the power supply to the Sensor first.
- Make sure that the cover to the Amplifier is in place before using the Sensor.
- If a writing error occurs (ERR/EEP will flash on the display) due to noise resulting from turning OFF the power supply, static electricity, or other cause, initialize the settings using the SET switch on the Amplifier.
- Depending on the application environment, some time may be required for the displayed distance to stabilize after turning ON the power supply.
- Output pulses may be generated when the power supply to the Amplifier is turned OFF. Turn OFF the load or the power supply to the load before turning OFF the Sensor.
- Do not use thinners, benzine, acetone, kerosene, or any other petroleum solvents to clean the Sensor or Amplifier.
- Turn OFF the power supply before connecting or disconnecting the Sensor Head.
Use only an E4C Sensor Head. The product may be damaged if any other Sensor Head is connected.
- The distance displayed on the Amplifier may be different from values obtained with tape measures or other devices.
To adjust the displayed distance, use the scaling function.

Mutual Interference

When installing two or more Sensor Heads side by side, ensure that the minimum distances given in the following table are maintained.

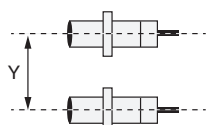

Model	Y
E4C-DS30/-DS30L	300 mm min.
E4C-DS80/-DS80L	800 mm min.
E4C-DS100	1,000 mm min.

* These distances are the separations at the maximum measurement distances. The degree of effect depends on the equipment and surrounding conditions. Check the degree of effect after you install the Sensor Heads in your operating environment.

Dimensions

(Unit: mm)
Tolerance class IT16 applies to dimensions in this data sheet unless otherwise specified.

Sensor Heads

E4C-DS30 E4C-DS80

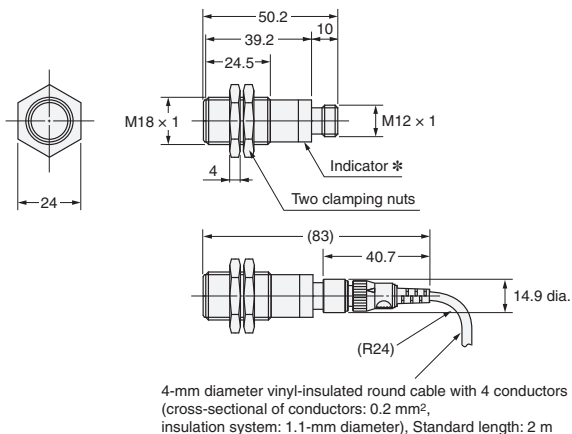

* Sensor within sensing range (yellow), Power indicator (green)

E4C-DS30L E4C-DS80L

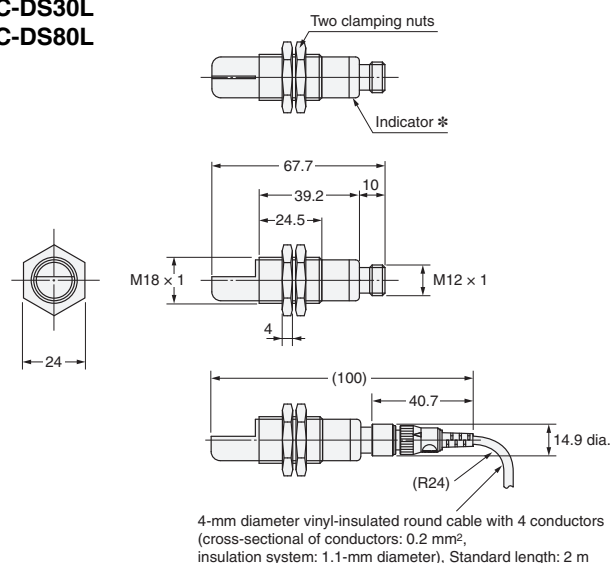

* Sensor within sensing range (yellow), Power indicator (green)

E4C-DS100

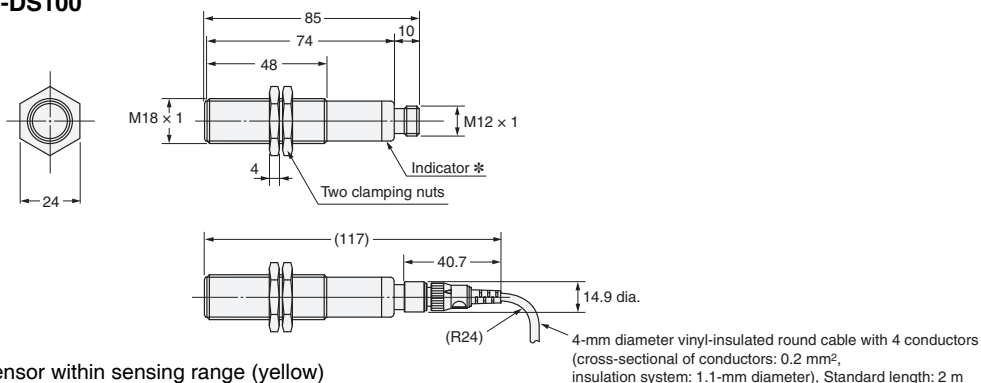

* Sensor within sensing range (yellow)

Amplifiers

E4C-UDA11 E4C-UDA41

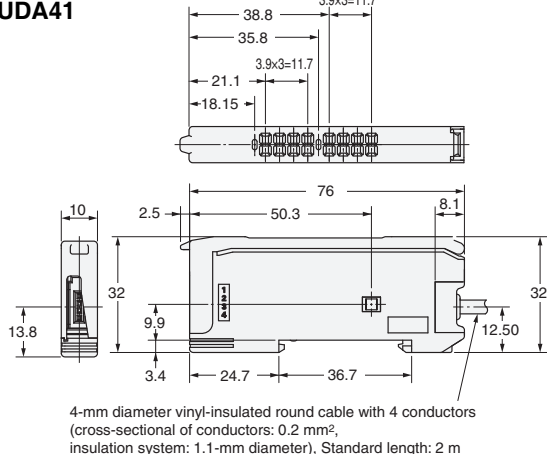

E4C-UDA11AN E4C-UDA41AN

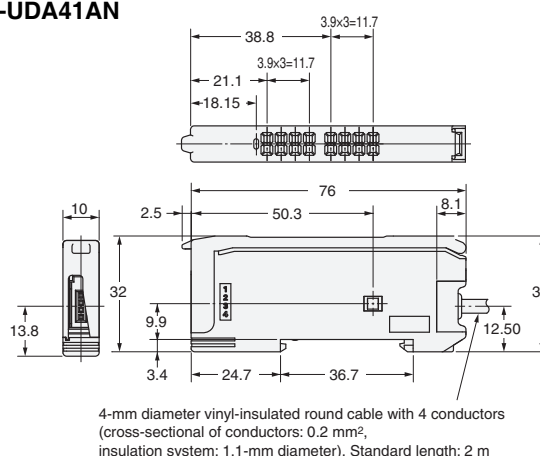

Terms and Conditions Agreement

Read and understand this catalog.

Please read and understand this catalog before purchasing the products. Please consult your OMRON representative if you have any questions or comments.

Warranties.

(a) Exclusive Warranty. Omron's exclusive warranty is that the Products will be free from defects in materials and workmanship for a period of twelve months from the date of sale by Omron (or such other period expressed in writing by Omron). Omron disclaims all other warranties, express or implied.

(b) Limitations. OMRON MAKES NO WARRANTY OR REPRESENTATION, EXPRESS OR IMPLIED, ABOUT NON-INFRINGEMENT, MERCHANTABILITY OR FITNESS FOR A PARTICULAR PURPOSE OF THE PRODUCTS. BUYER ACKNOWLEDGES THAT IT ALONE HAS DETERMINED THAT THE PRODUCTS WILL SUITABLY MEET THE REQUIREMENTS OF THEIR INTENDED USE.

Omron further disclaims all warranties and responsibility of any type for claims or expenses based on infringement by the Products or otherwise of any intellectual property right. (c) Buyer Remedy. Omron's sole obligation hereunder shall be, at Omron's election, to (i) replace (in the form originally shipped with Buyer responsible for labor charges for removal or replacement thereof) the non-complying Product, (ii) repair the non-complying Product, or (iii) repay or credit Buyer an amount equal to the purchase price of the non-complying Product; provided that in no event shall Omron be responsible for warranty, repair, indemnity or any other claims or expenses regarding the Products unless Omron's analysis confirms that the Products were properly handled, stored, installed and maintained and not subject to contamination, abuse, misuse or inappropriate modification. Return of any Products by Buyer must be approved in writing by Omron before shipment. Omron Companies shall not be liable for the suitability or unsuitability or the results from the use of Products in combination with any electrical or electronic components, circuits, system assemblies or any other materials or substances or environments. Any advice, recommendations or information given orally or in writing, are not to be construed as an amendment or addition to the above warranty.

See <http://www.omron.com/global/> or contact your Omron representative for published information.

Limitation on Liability; Etc.

OMRON COMPANIES SHALL NOT BE LIABLE FOR SPECIAL, INDIRECT, INCIDENTAL, OR CONSEQUENTIAL DAMAGES, LOSS OF PROFITS OR PRODUCTION OR COMMERCIAL LOSS IN ANY WAY CONNECTED WITH THE PRODUCTS, WHETHER SUCH CLAIM IS BASED IN CONTRACT, WARRANTY, NEGLIGENCE OR STRICT LIABILITY.

Further, in no event shall liability of Omron Companies exceed the individual price of the Product on which liability is asserted.

Suitability of Use.

Omron Companies shall not be responsible for conformity with any standards, codes or regulations which apply to the combination of the Product in the Buyer's application or use of the Product. At Buyer's request, Omron will provide applicable third party certification documents identifying ratings and limitations of use which apply to the Product. This information by itself is not sufficient for a complete determination of the suitability of the Product in combination with the end product, machine, system, or other application or use. Buyer shall be solely responsible for determining appropriateness of the particular Product with respect to Buyer's application, product or system. Buyer shall take application responsibility in all cases.

NEVER USE THE PRODUCT FOR AN APPLICATION INVOLVING SERIOUS RISK TO LIFE OR PROPERTY OR IN LARGE QUANTITIES WITHOUT ENSURING THAT THE SYSTEM AS A WHOLE HAS BEEN DESIGNED TO ADDRESS THE RISKS, AND THAT THE OMRON PRODUCT(S) IS PROPERLY RATED AND INSTALLED FOR THE INTENDED USE WITHIN THE OVERALL EQUIPMENT OR SYSTEM.

Programmable Products.

Omron Companies shall not be responsible for the user's programming of a programmable Product, or any consequence thereof.

Performance Data.

Data presented in Omron Company websites, catalogs and other materials is provided as a guide for the user in determining suitability and does not constitute a warranty. It may represent the result of Omron's test conditions, and the user must correlate it to actual application requirements. Actual performance is subject to the Omron's Warranty and Limitations of Liability.

Change in Specifications.

Product specifications and accessories may be changed at any time based on improvements and other reasons. It is our practice to change part numbers when published ratings or features are changed, or when significant construction changes are made. However, some specifications of the Product may be changed without any notice. When in doubt, special part numbers may be assigned to fix or establish key specifications for your application. Please consult with your Omron's representative at any time to confirm actual specifications of purchased Product.

Errors and Omissions.

Information presented by Omron Companies has been checked and is believed to be accurate; however, no responsibility is assumed for clerical, typographical or proofreading errors or omissions.

Mouser Electronics

Authorized Distributor

Click to View Pricing, Inventory, Delivery & Lifecycle Information:

[Omron:](#)

[E4C-DS80](#)

Компания «Океан Электроники» предлагает заключение долгосрочных отношений при поставках импортных электронных компонентов на взаимовыгодных условиях!

Наши преимущества:

- Поставка оригинальных импортных электронных компонентов напрямую с производств Америки, Европы и Азии, а так же с крупнейших складов мира;
- Широкая линейка поставок активных и пассивных импортных электронных компонентов (более 30 млн. наименований);
- Поставка сложных, дефицитных, либо снятых с производства позиций;
- Оперативные сроки поставки под заказ (от 5 рабочих дней);
- Экспресс доставка в любую точку России;
- Помощь Конструкторского Отдела и консультации квалифицированных инженеров;
- Техническая поддержка проекта, помощь в подборе аналогов, поставка прототипов;
- Поставка электронных компонентов под контролем ВП;
- Система менеджмента качества сертифицирована по Международному стандарту ISO 9001;
- При необходимости вся продукция военного и аэрокосмического назначения проходит испытания и сертификацию в лаборатории (по согласованию с заказчиком);
- Поставка специализированных компонентов военного и аэрокосмического уровня качества (Xilinx, Altera, Analog Devices, Intersil, Interpoint, Microsemi, Actel, Aeroflex, Peregrine, VPT, Syfer, Eurofarad, Texas Instruments, MS Kennedy, Miteq, Cobham, E2V, MA-COM, Hittite, Mini-Circuits, General Dynamics и др.);

Компания «Океан Электроники» является официальным дистрибьютором и эксклюзивным представителем в России одного из крупнейших производителей разъемов военного и аэрокосмического назначения «JONHON», а так же официальным дистрибьютором и эксклюзивным представителем в России производителя высокотехнологичных и надежных решений для передачи СВЧ сигналов «FORSTAR».



JONHON

«JONHON» (основан в 1970 г.)

Разъемы специального, военного и аэрокосмического назначения:

(Применяются в военной, авиационной, аэрокосмической, морской, железнодорожной, горно- и нефтедобывающей отраслях промышленности)

«FORSTAR» (основан в 1998 г.)

ВЧ соединители, коаксиальные кабели, кабельные сборки и микроволновые компоненты:

(Применяются в телекоммуникациях гражданского и специального назначения, в средствах связи, РЛС, а так же военной, авиационной и аэрокосмической отраслях промышленности).



Телефон: 8 (812) 309-75-97 (многоканальный)

Факс: 8 (812) 320-03-32

Электронная почта: ocean@oceanchips.ru

Web: <http://oceanchips.ru/>

Адрес: 198099, г. Санкт-Петербург, ул. Калинина, д. 2, корп. 4, лит. А