

# LT3094

## –20V, 500mA, Ultralow Noise, Ultrahigh PSRR Negative Linear Regulator

### DESCRIPTION

Demonstration circuit 2624A features the [LT<sup>®</sup>3094](#), an ultralow noise, ultrahigh power supply rejection ratio (PSRR) negative low dropout (LDO) regulator. DC2624A operates over an input range of –3.8V to –20V, and can deliver up to 500mA output current. It features ultralow noise ( $0.8\mu\text{V}_{\text{RMS}}$  from 10Hz to 100kHz) and very high PSRR (75dB at 1MHz).

The LT3094 enable function (EN/UVLO pin) is bidirectional and can be controlled with either a positive or a negative voltage. The LT3094 also offers programmable current limit functionality by connecting a resistor from  $I_{\text{LIM}}$  to GND. Current monitoring is also achieved by sensing the  $I_{\text{LIM}}$  pin voltage. The  $V_{\text{IOC}}$  tracking function controls an upstream switching converter to maintain a constant voltage across the regulator and, hence, minimize power dissipation. The power good feedback (PGFB) pin is used to set a programmable power good threshold, and activates

the fast start-up circuitry. To use the power good function, connect an external voltage source at  $V_{\text{EXT}}$ . If power good and fast start-up functionality are not needed, tie PGFB to IN.

Built-in protection includes reverse battery protection, reverse current protection, internal current limit with fold-back, and thermal limit with hysteresis.

The LT3094 data sheet gives a complete description of the part, operation and applications information. The data sheet must be read in conjunction with this demo manual for demonstration circuit DC2624A. The LT3094 is assembled in 12-lead MSOP and 3mm × 3mm DFN packages with an exposed pad on the bottom-side of the IC. Proper board layout is essential for maximum thermal performance.

[Design files for this circuit board are available.](#)

All registered trademarks and trademarks are the property of their respective owners.

### PERFORMANCE SUMMARY Specifications are at $T_A = 25^\circ\text{C}$

PARAMETERS	CONDITIONS	MIN	TYP	MAX	UNITS
Input Voltage Range ( $V_{\text{IN}}$ )	$I_{\text{OUT}} = 150\text{mA}$ , $V_{\text{OUT}} = -3.3\text{V}$	–20		–3.8	V
Input Voltage Range ( $V_{\text{IN}}$ )	$I_{\text{OUT}} = 500\text{mA}$ , $V_{\text{OUT}} = -3.3\text{V}$	–7*		–3.8	V
Output Voltage ( $V_{\text{OUT}}$ )	$V_{\text{IN}} = -5\text{V}$ , $I_{\text{OUT}} = 500\text{mA}$	–3.39	–3.32	–3.25	V
Shutdown Input Current ( $I_{\text{IN}}$ )	$V_{\text{EN}} = 0\text{V}$ , $V_{\text{IN}} = -5\text{V}$		5		$\mu\text{A}$

\*The maximum input voltage for 500mA load current is set by the 60°C temperature rise of LT3094 on the demo circuit. Higher input voltages can be applied if a larger copper area and/or forced-air cooling is applied. The output current is also limited by the differential of input and output voltage. Please refer to the data sheet for details.

## QUICK START PROCEDURE

Demonstration circuit 2624A is easy to set up to evaluate the performance of the LT3094EDD. Refer to Figure 1 for proper measurement equipment setup and follow the procedure below:

1. Connect a load between the  $V_{OUT}$  and GND terminals.
2. With power off, connect the input power supply to the  $V_{IN}$  and GND terminals.
3. Apply  $-3.8V$  across  $V_{IN}$  to GND. The output voltage should be  $-3.32V \pm 3%$  ( $-3.39V$  to  $-3.25V$ ).

4. Vary  $V_{IN}$  from  $-3.8V$  to  $-20V$  and vary the load current from  $0mA$  to  $500mA$ .

Note: Make sure the power dissipation is below the thermal limit.

5. Apply a power source at  $V_{EXT}$ . The PG pin voltage should be approximately equal to  $V_{EXT}$ .
6. Refer to Application Notes AN70 and AN159 for measuring output noise and PSRR.

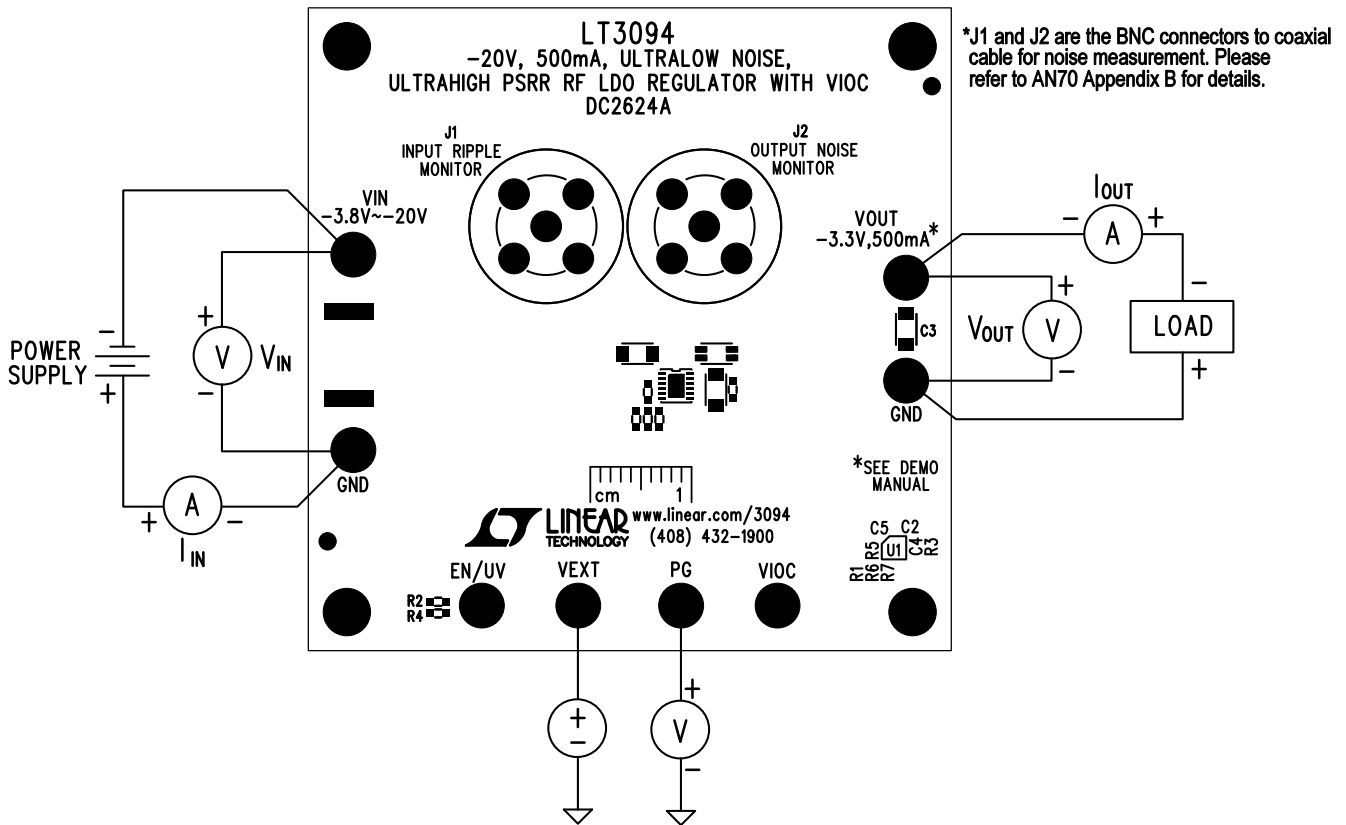

\*The maximum output current will be limited by internal current limit based on differential voltage of input and output voltage. Please refer to the datasheet.

Figure 1. Test Procedure Setup Drawing for DC2624A

## PCB LAYOUT

### Best PSRR Performance: PCB Layout for Input Trace

For applications utilizing the LT3094 for post-regulating switching converters, placing a capacitor directly at the LT3094 input results in AC current (at the switching frequency) flowing near the LT3094. Without careful attention to PCB layout, this relatively high frequency switching current generates an electromagnetic field (EMF) that couples to the LT3094 output, thereby degrading its effective PSRR. Highly dependent on the PCB, the switching preregulator, and the input capacitor size, among other factors, the PSRR degradation can easily be 30dB at 1MHz. This

degradation is present even if the LT3094 is desoldered from the board, because it effectively degrades the PSRR of the PC board itself. While negligible for conventional low PSRR LDOs, LT3094's ultrahigh PSRR requires careful attention to higher order parasitics in order to realize the full performance offered by the regulator.

The LT3094 demo board alleviates this degradation in PSRR by using a specialized layout technique. In Figure 2, the input trace ( $V_{IN}$ ) is highlighted in red together with input capacitor C1, and in Figure 3 the return path (GND) is also highlighted. Normally when

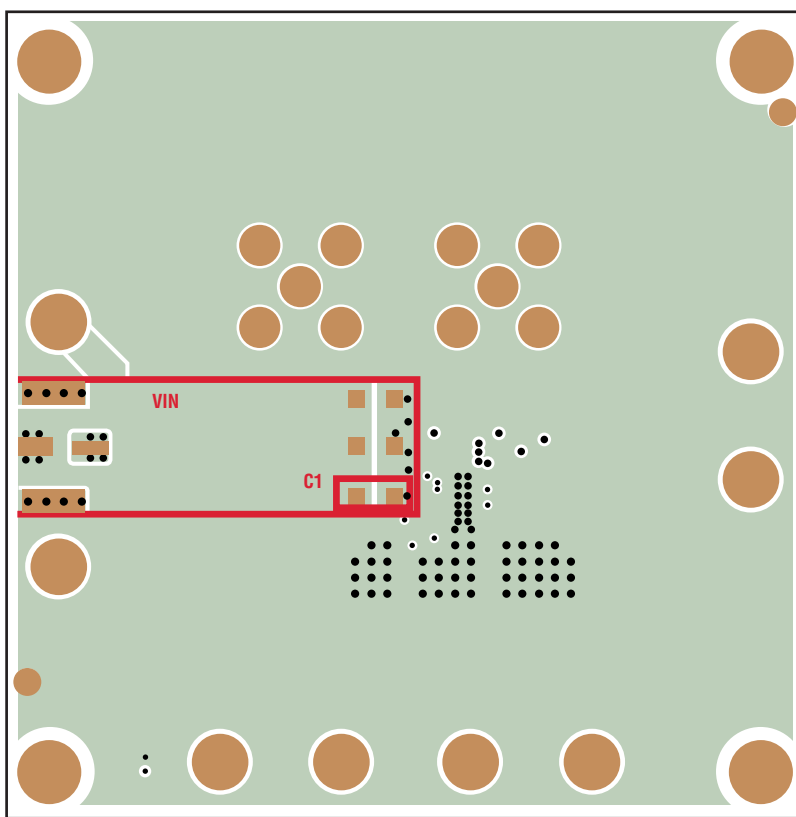

Figure 2. Bottom Layer of DC2624A

## PCB LAYOUT

an AC voltage is applied to the input of the board, AC current flows on this path, thus generating EMF. This EMF couples to output capacitor C2 and related traces, making the PSRR appear worse than it actually is. *With the input trace directly above the return path, the EMFs are in opposite directions, and consequently cancel each other out. Making sure these traces exactly overlap each other maximizes the cancellation effect and thus provides the maximum PSRR offered by the regulator.*

### Best AC Performance: PCB Layout for Output Capacitors C2

For ultrahigh PSRR performance, the LT3094 bandwidth is quite high (~1MHz), making it very close to the output capacitor's self-resonance frequency (~1.6MHz). Therefore, it is very important to avoid adding extra impedance (ESL & ESR) outside the feedback loop. To that end, minimize the effects of PCB trace and solder inductance by Kelvin connecting OUTS and SET pin capacitor GND directly to output capacitors (C2) terminals using split capacitor techniques as shown in Figure 4 and Figure 5. With only small AC current flowing through these connections, the impact of solder joint/PCB trace inductance on stability is eliminated. While the LT3094 is robust enough not to oscillate if the recommended layout is not followed, phase/gain margin and stability will degrade.

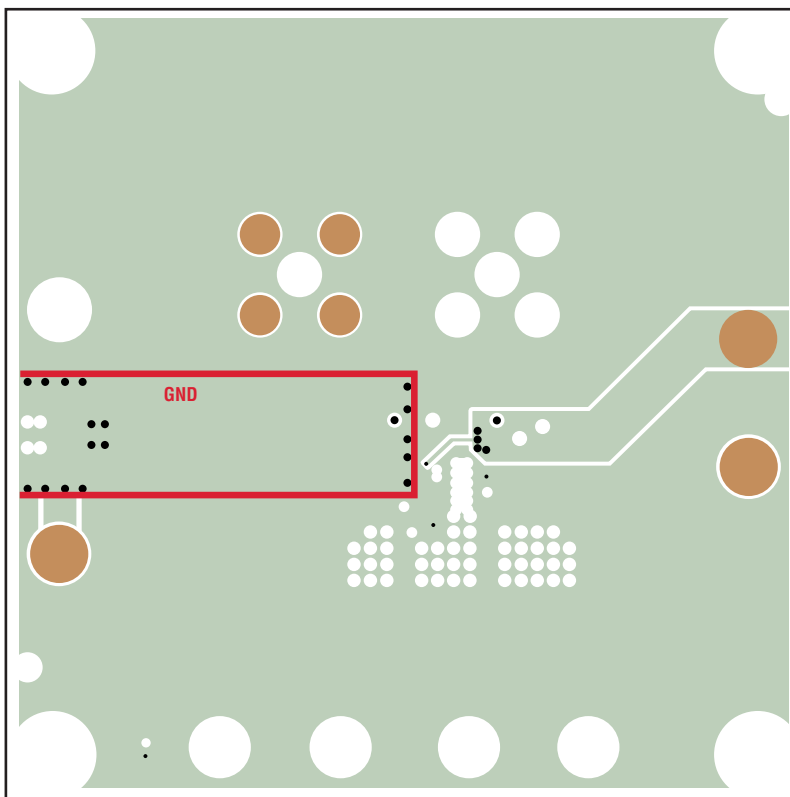

DC2624a F03

Figure 3. Layer 3 of DC2624A

PCB LAYOUT

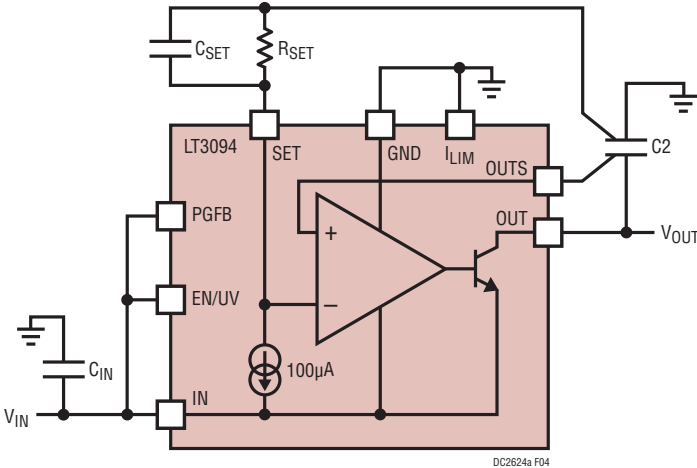

Figure 4. C2 and CSET Connections for Best Performance

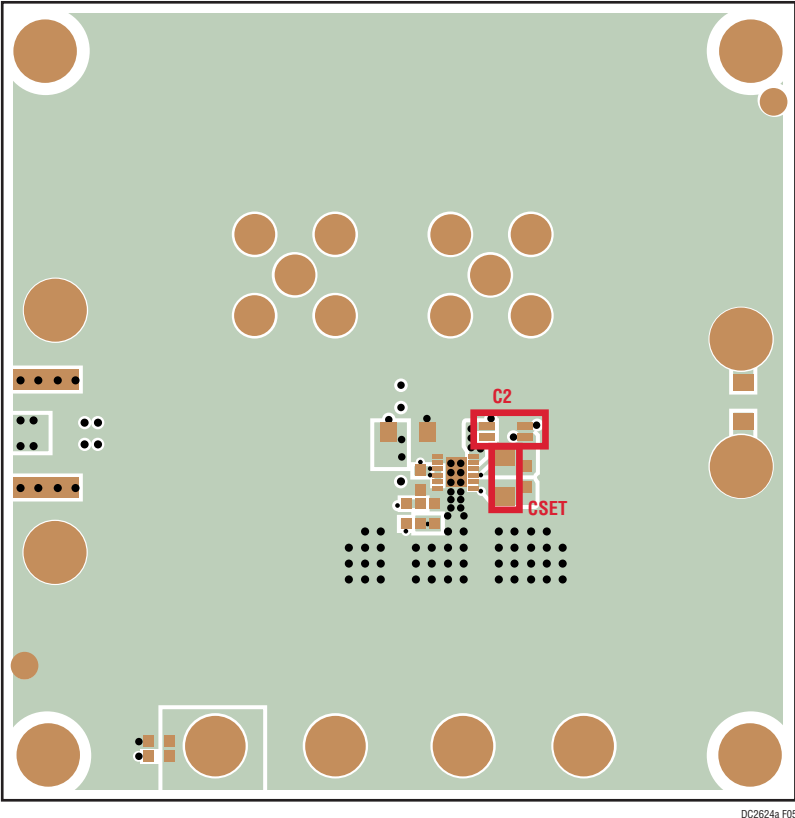

Figure 5. Split Pads for Output Capacitors on Top Layer of DC2624A

# DEMO MANUAL DC2624A

## PARTS LIST

ITEM	QTY	REFERENCE	PART DESCRIPTION	MANUFACTURER/PART NUMBER
<b>Required Circuit Components</b>				
1	1	C1N	CAP, ALUM, 22 $\mu$ F, 35V, 5X5.4MM	SUN ELECTRONIC INDUSTRIES CORP, 35CE22BSS
2	2	C1, C4	CAP, X7R, 4.7 $\mu$ F, 25V, 10% 1206	MURATA, GRM31CR71E475KA88L
3	1	C2	CAP, X5R, 10 $\mu$ F, 25V, 10% 1206	MURATA, GJ831CR61E106KE83L
4	1	R1	RES, CHIP, 200k, 1/10W, 5% 0603	VISHAY, CRCW0603200KJNEA
5	1	R2	RES, CHIP, 100k, 1/10W, 1% 0603	VISHAY, CRCW0603100KFKEA
6	1	R3	RES, CHIP, 33.2k, 1/10W, 1% 0603	VISHAY, CRCW060333K2FKEA
7	1	R5	RES, CHIP, 453k, 1/10W, 1% 0603	VISHAY, CRCW0603453KFKEA
8	1	R6	RES, CHIP, 49.9k, 1/10W, 1% 0603	VISHAY, CRCW060349K9FKEA
9	1	R7	RES, CHIP, 4.99k, 1/10W, 1% 0603	VISHAY, CRCW06034K99FKEA
10	1	U1	IC, LT3094EDD, 12DFN	ANALOG DEVICES, LT3094EDD#PBF
<b>Additional Demo Board Circuit Components</b>				
1	0	C3, C5 (OPT)	CAP, OPTION, 1206	
2	0	R4 (OPT)	RES, OPTION, 0603	
<b>Hardware: For Demo Board Only</b>				
1	8	E1 TO E8	TESTPOINT, TURRET, 0.094" PBF	MILL-MAX, 2501-2-00-80-00-00-07-0
2	2	J1, J2	CONN, BNC, 5 PINS	CONNEX, 112404
3	4	MH1 TO MH4	STAND-OFF, NYLON 6.4mm	WURTH ELEKTRONIK, 702931000

# SCHEMATIC DIAGRAM

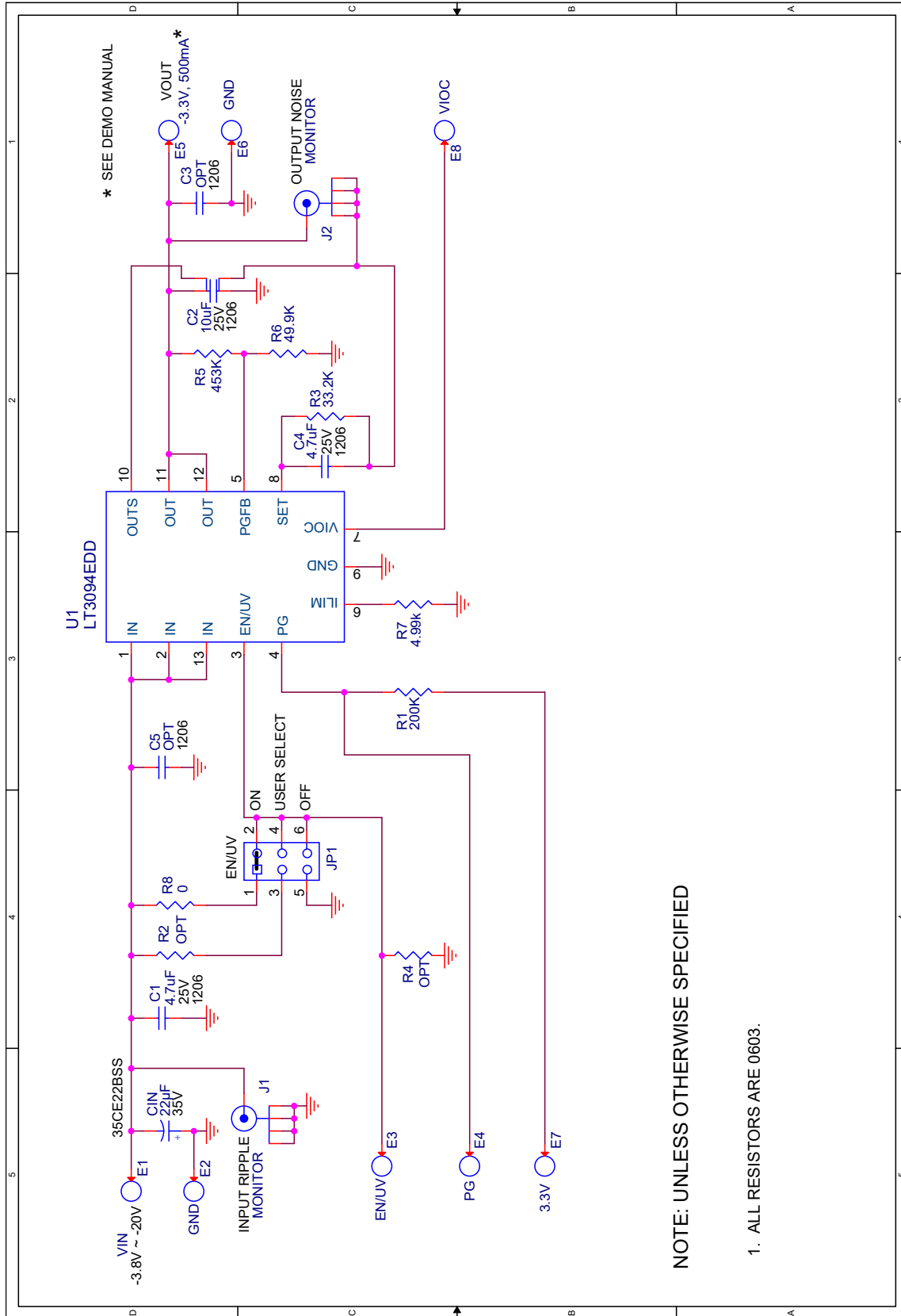

NOTE: UNLESS OTHERWISE SPECIFIED

1. ALL RESISTORS ARE 0603.



## ESD Caution

**ESD (electrostatic discharge) sensitive device.** Charged devices and circuit boards can discharge without detection. Although this product features patented or proprietary protection circuitry, damage may occur on devices subjected to high energy ESD. Therefore, proper ESD precautions should be taken to avoid performance degradation or loss of functionality.

## Legal Terms and Conditions

By using the evaluation board discussed herein (together with any tools, components documentation or support materials, the "Evaluation Board"), you are agreeing to be bound by the terms and conditions set forth below ("Agreement") unless you have purchased the Evaluation Board, in which case the Analog Devices Standard Terms and Conditions of Sale shall govern. Do not use the Evaluation Board until you have read and agreed to the Agreement. Your use of the Evaluation Board shall signify your acceptance of the Agreement. This Agreement is made by and between you ("Customer") and Analog Devices, Inc. ("ADI"), with its principal place of business at One Technology Way, Norwood, MA 02062, USA. Subject to the terms and conditions of the Agreement, ADI hereby grants to Customer a free, limited, personal, temporary, non-exclusive, non-sublicensable, non-transferable license to use the Evaluation Board FOR EVALUATION PURPOSES ONLY. Customer understands and agrees that the Evaluation Board is provided for the sole and exclusive purpose referenced above, and agrees not to use the Evaluation Board for any other purpose. Furthermore, the license granted is expressly made subject to the following additional limitations: Customer shall not (i) rent, lease, display, sell, transfer, assign, sublicense, or distribute the Evaluation Board; and (ii) permit any Third Party to access the Evaluation Board. As used herein, the term "Third Party" includes any entity other than ADI, Customer, their employees, affiliates and in-house consultants. The Evaluation Board is NOT sold to Customer; all rights not expressly granted herein, including ownership of the Evaluation Board, are reserved by ADI. CONFIDENTIALITY. This Agreement and the Evaluation Board shall all be considered the confidential and proprietary information of ADI. Customer may not disclose or transfer any portion of the Evaluation Board to any other party for any reason. Upon discontinuation of use of the Evaluation Board or termination of this Agreement, Customer agrees to promptly return the Evaluation Board to ADI. ADDITIONAL RESTRICTIONS. Customer may not disassemble, decompile or reverse engineer chips on the Evaluation Board. Customer shall inform ADI of any occurred damages or any modifications or alterations it makes to the Evaluation Board, including but not limited to soldering or any other activity that affects the material content of the Evaluation Board. Modifications to the Evaluation Board must comply with applicable law, including but not limited to the RoHS Directive. TERMINATION. ADI may terminate this Agreement at any time upon giving written notice to Customer. Customer agrees to return to ADI the Evaluation Board at that time. LIMITATION OF LIABILITY. THE EVALUATION BOARD PROVIDED HEREUNDER IS PROVIDED "AS IS" AND ADI MAKES NO WARRANTIES OR REPRESENTATIONS OF ANY KIND WITH RESPECT TO IT. ADI SPECIFICALLY DISCLAIMS ANY REPRESENTATIONS, ENDORSEMENTS, GUARANTEES, OR WARRANTIES, EXPRESS OR IMPLIED, RELATED TO THE EVALUATION BOARD INCLUDING, BUT NOT LIMITED TO, THE IMPLIED WARRANTY OF MERCHANTABILITY, TITLE, FITNESS FOR A PARTICULAR PURPOSE OR NON-INFRINGEMENT OF INTELLECTUAL PROPERTY RIGHTS. IN NO EVENT WILL ADI AND ITS LICENSORS BE LIABLE FOR ANY INCIDENTAL, SPECIAL, INDIRECT, OR CONSEQUENTIAL DAMAGES RESULTING FROM CUSTOMER'S POSSESSION OR USE OF THE EVALUATION BOARD, INCLUDING BUT NOT LIMITED TO LOST PROFITS, DELAY COSTS, LABOR COSTS OR LOSS OF GOODWILL. ADI'S TOTAL LIABILITY FROM ANY AND ALL CAUSES SHALL BE LIMITED TO THE AMOUNT OF ONE HUNDRED US DOLLARS (\$100.00). EXPORT. Customer agrees that it will not directly or indirectly export the Evaluation Board to another country, and that it will comply with all applicable United States federal laws and regulations relating to exports. GOVERNING LAW. This Agreement shall be governed by and construed in accordance with the substantive laws of the Commonwealth of Massachusetts (excluding conflict of law rules). Any legal action regarding this Agreement will be heard in the state or federal courts having jurisdiction in Suffolk County, Massachusetts, and Customer hereby submits to the personal jurisdiction and venue of such courts. The United Nations Convention on Contracts for the International Sale of Goods shall not apply to this Agreement and is expressly disclaimed.



Компания «Океан Электроники» предлагает заключение долгосрочных отношений при поставках импортных электронных компонентов на взаимовыгодных условиях!

Наши преимущества:

- Поставка оригинальных импортных электронных компонентов напрямую с производств Америки, Европы и Азии, а так же с крупнейших складов мира;
- Широкая линейка поставок активных и пассивных импортных электронных компонентов (более 30 млн. наименований);
- Поставка сложных, дефицитных, либо снятых с производства позиций;
- Оперативные сроки поставки под заказ (от 5 рабочих дней);
- Экспресс доставка в любую точку России;
- Помощь Конструкторского Отдела и консультации квалифицированных инженеров;
- Техническая поддержка проекта, помощь в подборе аналогов, поставка прототипов;
- Поставка электронных компонентов под контролем ВП;
- Система менеджмента качества сертифицирована по Международному стандарту ISO 9001;
- При необходимости вся продукция военного и аэрокосмического назначения проходит испытания и сертификацию в лаборатории (по согласованию с заказчиком);
- Поставка специализированных компонентов военного и аэрокосмического уровня качества (Xilinx, Altera, Analog Devices, Intersil, Interpoint, Microsemi, Actel, Aeroflex, Peregrine, VPT, Syfer, Eurofarad, Texas Instruments, MS Kennedy, Miteq, Cobham, E2V, MA-COM, Hittite, Mini-Circuits, General Dynamics и др.);

Компания «Океан Электроники» является официальным дистрибьютором и эксклюзивным представителем в России одного из крупнейших производителей разъемов военного и аэрокосмического назначения «JONHON», а так же официальным дистрибьютором и эксклюзивным представителем в России производителя высокотехнологичных и надежных решений для передачи СВЧ сигналов «FORSTAR».



## JONHON

«JONHON» (основан в 1970 г.)

Разъемы специального, военного и аэрокосмического назначения:

(Применяются в военной, авиационной, аэрокосмической, морской, железнодорожной, горно- и нефтедобывающей отраслях промышленности)

«FORSTAR» (основан в 1998 г.)

ВЧ соединители, коаксиальные кабели, кабельные сборки и микроволновые компоненты:

(Применяются в телекоммуникациях гражданского и специального назначения, в средствах связи, РЛС, а так же военной, авиационной и аэрокосмической отраслях промышленности).



Телефон: 8 (812) 309-75-97 (многоканальный)

Факс: 8 (812) 320-03-32

Электронная почта: [ocean@oceanchips.ru](mailto:ocean@oceanchips.ru)

Web: <http://oceanchips.ru/>

Адрес: 198099, г. Санкт-Петербург, ул. Калинина, д. 2, корп. 4, лит. А