

PSR-PS20



SIL coupling relay



Data sheet
106252_en_02

© PHOENIX CONTACT 2015-07-14

1 Description

Intended Use

The **PSR-PS20** SIL coupling relay can be used for power adaptation and electrical isolation in high and low-demand applications up to SIL 3 according to IEC 61508 as well as EN 61511.

Using this module, circuits are interrupted in a safety-oriented manner.

The safety relay is equipped with an enabling current path and a confirmation current path that drop out without delay according to stop category 0 in accordance with EN 60204-1.

By filtering the controller test pulses, premature failure of the safety relays is prevented.

If an error occurs inside the module, the internal device input impedance is affected. As such with compatible, safe systems, the test pulses sent from the controller may be disrupted and the error can be reported back to the corresponding digital output without any additional wiring effort.

Features

- SIL 3 coupling relay for safety-related switching off
- Can be used in high and low-demand applications
- Approved for Class I, Zone 2 applications
- Easy proof test:
 - Active error acknowledgment via A1
 - Visually on the device
 - Evaluation of the force-guided N/C contact
- Integrated DCS test pulse filter
- Low inrush current
- 1 undelayed enabling current path
- 1 undelayed confirmation current path
- 1 digital signal output
- Fixed screw connection
- 6.8 mm housing width
- Controller-specific Termination Carrier available on request



WARNING: Risk of electric shock

Observe the safety instructions in the corresponding section!



Make sure you always use the latest documentation.
It can be downloaded from the product at phoenixcontact.net/products.



This data sheet is valid for all products listed on the following pages.

2	Table of contents	
1	Description	1
2	Table of contents	2
3	Ordering data	3
4	Technical data	3
5	Safety notes.....	6
	5.1 Installation in the Ex area (class I, zone 2).....	7
	5.2 Installation in areas with a danger of dust explosions	7
6	Basic circuit diagram	8
7	Derating.....	8
	7.1 Vertical mounting position	8
	7.2 Horizontal mounting position	8
	7.3 Mounting position with module front at the top.....	9
8	Load curve.....	9
	8.1 Ohmic load	9
9	Operating and indication elements	10
	9.1 Connection versions.....	10
	9.2 Connection assignment.....	10
10	Mounting and connection	11
11	Startup.....	11
12	Proof test	11
13	Calculating the power dissipation	12
14	Application examples	13
	14.1 Application example 1 - SIL 3.....	13
15	Revision history	14

3 Ordering data

Description	Type	Order No.	Pcs. / Pkt.
Coupling relay for SIL 3 high and low-demand applications, couples digital output signals to the I/O, 1 enabling current path, 1 confirmation current path, 1 digital signal output, safe state off applications, test pulse filter, fixed screw terminal block	PSR-PS20-1NO-1NC-24DC-SC	2700356	1

4 Technical data

Hardware/firmware version	
HW/FW	≥ 00/-- (The technical data and safety characteristics are valid as of the specified HW/FW version.)
Input data	
Rated control supply voltage U_S	24 V DC -15 % / +10 %
Rated control supply current I_S	typ. 45 mA
Supply voltage	24 V DC -15 % / +10 % (Diagnostic supply voltage U_D)
Input current	6 mA (at 21-A2 for U_D ; depending on load + 100 mA at M1 and 22)
Typical inrush current	400 mA ($\Delta t < 10 \mu s$ at U_S) 2.5 A ($\Delta t < 20 \mu s$ at U_D)
Power consumption at U_S	typ. 1.08 W
Filter time	max. 2 ms (at A1-A2; test pulse width) ≥ 100 ms (at A1-A2; test pulse rate)
Typical starting time with U_S	< 100 ms (when controlled via A1)
Typical release time with U_S	< 35 ms (when controlled via A1)
Recovery time	500 ms
Maximum switching frequency	1 Hz
Operating voltage display	1 x yellow LED
Status display	2 x green LEDs
Indication	1 x red LED
Protective circuit	Surge protection Suppressor diode Polarity reversal protection for rated control supply voltage and diagnostic supply voltage
Output data	
Contact type	1 enabling current path 1 confirmation current path
Contact material	AgSnO ₂ (enabling current path) AgCuNi, + Au (confirmation current path)
Minimum switching voltage	20 V AC/DC (N/O contact) 20.4 V DC (N/C contact)
Maximum switching voltage	250 V AC/DC (N/O contact) 26.4 V DC (N/C contact)
Nominal current	6 A (N/O contact)
Limiting continuous current	6 A (N/O contact) 100 mA (N/C contact)
Maximum inrush current	6 A (N/O contact) 100 mA (N/C contact)
Inrush current, minimum	3 mA (N/O contact) 1 mA (N/C contact)
Sq. Total current	36 A ² (see to derating)

Output data	
Switching capacity min.	60 mW
Mechanical service life	10 x 10 ⁶ cycles
Output fuse	6 A gL/gG (N/O contact) 4 A gL/gG (for low-demand applications) 150 mA fast blow (Confirmation current path)

Alarm outputs	
Number of outputs	1 (digital, PNP)
Voltage	22 V DC (U _D - 2 V)
Current	max. 100 mA
Maximum inrush current	500 mA ($\Delta t = 1$ ms at U _S)
Short-circuit protection	no

General data	
Relay type	Electromechanically forcibly guided, dust-proof relay.
Nominal operating mode	100% operating factor
Degree of protection	IP20
Min. degree of protection of inst. location	IP54
Mounting type	DIN rail mounting
Mounting position	vertical, horizontal, with front of module upward
Assembly instructions	See derating curve
Dimensions (W/H/D)	6.8 x 93.1 x 102.5 mm
Type of housing	PBT yellow
Clearances and creepage distances between the power circuits	DIN EN 50178, EN 60079-15
Rated insulation voltage	250 V AC
Rated surge voltage/insulation	Safe isolation, 6 kV reinforced insulation from control circuit, start circuit, confirmation current path, signal output to the enabling current path; 4 kV/basic insulation between all current paths and housing
Pollution degree	2
Surge voltage category	III

Connection data	
Connection method	Screw connection
Conductor cross section, solid	0.2 mm ² ... 2.5 mm ²
Conductor cross section, stranded	0.2 mm ² ... 2.5 mm ²
Conductor cross section AWG/kcmil	26 ... 12
Stripping length	12 mm
Screw thread	M3

Ambient conditions	
Ambient temperature (operation)	-40 °C ... 70 °C (observe derating)
Ambient temperature (storage/transport)	-40 °C ... 85 °C
Max. permissible relative humidity (operation)	75 % (on average, 85% infrequently, non-condensing)
Max. permissible humidity (storage/transport)	75 % (on average, 85% infrequently, non-condensing)
Maximum altitude	max. 2000 m (Above sea level)
Shock	15g
Vibration (operation)	2g

Conformance / approvals	
Conformance	CE-compliant
Approvals	
UL, USA / Canada (E140324)	cULus

Conformance / approvals

UL, USA / Canada (E360692)	Class I, Zone 2, AEx nA nC IIC T4 / Ex nA nC IIC Gc T4 X
Shipbuilding	GL applied for
Functional Safety in accordance with IEC 61508	to SIL 3

Safety data

Stop category according to IEC 60204	0
--------------------------------------	---

Safety parameters for IEC 61508 - High demand

Equipment type	Type A
HFT	1
SIL	3 (< 15% of the overall SIL)
PFH _d	1.95×10^{-10} (4 A DC13; 5 A AC15; 8760 switching cycles/year)
Demand rate	< 12 Months
Proof test interval	240 Months
Duration of use	240 Months

For use in high-demand applications, the diagnostics function must be implemented via the confirmation current path.

Alternative illustration of the device as 1001 structure for process customers

Equipment type	Type A
HFT	0
SIL	3 (< 15% of the overall SIL)
Safe Failure Fraction (SFF)	99.98 %
λ_{SD}	989.32 FIT
λ_{SU}	148.96 FIT
λ_{DD}	52.58 FIT
λ_{DU}	0.20 FIT
λ_{Total}	1191.06 FIT
MTBF	80.63 Years
PFH	1.95×10^{-10} (4 A DC13; 5 A AC15; 8760 switching cycles/year)

Safety parameters for IEC 61508 - Low demand

Equipment type	Type A
HFT	1
SIL	3 (< 15% of the overall SIL)
PFD _{avg}	1.27×10^{-4}
Proof test interval	72 Months
Duration of use	240 Months

Alternative illustration of the device as 1001 structure for process customers

Equipment type	Type A
HFT	0
SIL	3 (< 15% of the overall SIL)
Safe Failure Fraction (SFF)	99.66 %
λ_{SD}	0 FIT
λ_{SU}	1579 FIT
λ_{DD}	0 FIT
λ_{DU}	5.392 FIT
λ_{Total}	1584 FIT
MTBF	63 Years
PFD _{avg}	2.36×10^{-5} (For T1 = 1 year)

5 Safety notes



WARNING: Risk of electric shock

During operation, parts of electrical switching devices carry hazardous voltages.

Before working on the switching device, disconnect the power.

Please observe the safety regulations of electrical engineering and industrial safety and liability associations!

Disregarding these safety regulations may result in death, serious personal injury or damage to equipment.

Startup, mounting, modifications, and upgrades should only be carried out by a skilled electrical engineer!



WARNING: Risk of automatic machine restart!

For emergency stop applications, the machine must be prevented from restarting automatically by a higher-level control system.

Protective covers must not be removed when operating electrical switching devices.



WARNING: Danger due to faulty devices!

The devices may be damaged following an error and correct operation can no longer be ensured.

In the event of an error, replace the device immediately.

Repairs to the device, especially if the housing must be opened, may only be carried out by the manufacturer or authorized persons. Otherwise the warranty is invalidated.



WARNING: Risk due to incorrect installation

For reliable operation, the safety relay must be installed in housing protected from dust and humidity (IP54).

Carry out wiring according to the application. Refer to the "Application examples" section for this.



WARNING: Risk due to welded relay contacts

A suitable and effective protective circuit is to be provided for inductive loads. This is to be implemented parallel to the load and not parallel to the switch contact.



WARNING: danger due to magnetic interference!

Do not use the device in the vicinity of strong magnetic fields (e.g., caused by transformers or magnetic iron). The magnetic field strength of the environment must not exceed 30 A/m.



NOTE: Risk of damage to equipment due to noise emissions

When operating relay modules the operator must meet the requirements for noise emission for electrical and electronic equipment (EN 61000-6-4) on the contact side and, if required, take appropriate measures.



NOTE: Risk of damage to equipment due to noise emissions

This is a Class A product. In a domestic environment it may cause radion interference, in which case the user may be required to take adequate measures.



Only use power supply units with safe isolation and SELV / PELV in accordance with EN 50178/VDE 0160 (SELV / PELV).



NOTE: Electrostatic discharge!

The device contains components that can be damaged or destroyed by electrostatic discharge. When handling the device, observe the necessary safety precautions against electrostatic discharge (ESD) according to EN 61340-5-1 and EN 61340-5-2.

5.1 Installation in the Ex area (class I, zone 2)



WARNING: Explosion hazard

The device should be installed in a housing (control or distributor box) that fulfills the requirements of EN 60079-15:2010 (IEC 60079-15:2010 4th ED.) and at least IP54 (EN/ IEC 60529) degree of protection.



WARNING: Explosion hazard

The device must be used in no more than a pollution degree 2 environment as defined by EN/ IEC 60664-1.



WARNING: Explosion hazard

When installing and connecting the supply and signal circuits observe the requirements of EN/ IEC 60079-14. Only devices suitable for operation in Ex zone 2 and the conditions at the application site may be connected to the circuits in zone 2.

In potentially explosive areas, only connect and disconnect cables when the power is disconnected.



WARNING: Explosion hazard

The device must be stopped and immediately removed from the Ex area if it is damaged or was subject to an impermissible load or stored incorrectly or if it malfunctions.

Ambient temperature in hazardous areas (class I, zone 2)

Observe the derating curves.

Observe the special temperature conditions according to the rating plate.

	NO-contact	DO-contact
Output	250 V AC / 24 V DC 6 A, Resistive B300, R300	24 V DC 100 mA Resistive
Ambient Temperature	-20 °C to 65 °C	

5.2 Installation in areas with a danger of dust explosions



WARNING: Explosion hazard

The device is not designed for use in atmospheres with a danger of dust explosions.

6 Basic circuit diagram

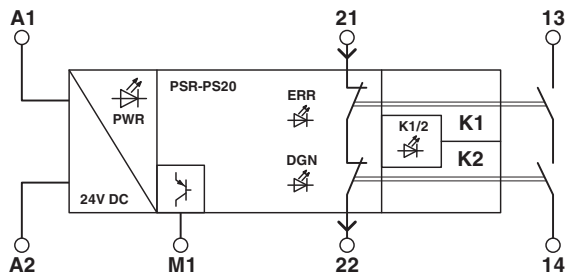

Figure 1 Block diagram

Key:

Designation	Explanation
A1	+24 V control input with active error acknowledgment
A2	0 V (GND)
M1	Signal output (PNP)
21	+24 V diagnostics input
22	Diagnostic output +24 V
13/14	Enabling current path, undelayed



Confirmation current path 21/22 (N/C contact) is **not** an electrically isolated current path and may only be connected to a maximum voltage of 26.4 V in relation to A2.

7 Derating

7.1 Vertical mounting position

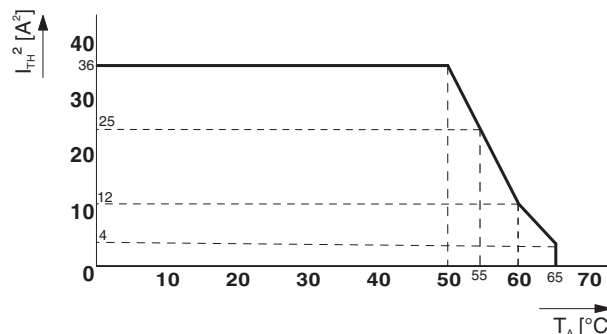

Figure 2 Derating curve - vertical mounting position with connected modules

Expanded ambient temperature range (with no distance): up to +70 °C

Conditions:

Max. rated control supply voltage 24 V DC
 Max. total current of the enabling current path 1 A²

7.2 Horizontal mounting position

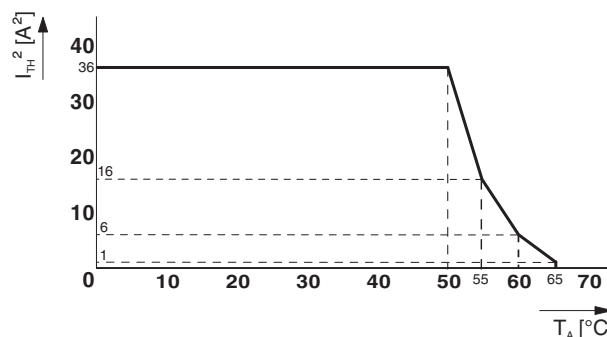

Figure 3 Derating curve - horizontal mounting position with connected modules

Expanded ambient temperature range (with no distance): up to +70 °C

Conditions:

Max. rated control supply voltage 24 V DC
 Max. total current of the enabling current path 250 mA²

7.3 Mounting position with module front at the top

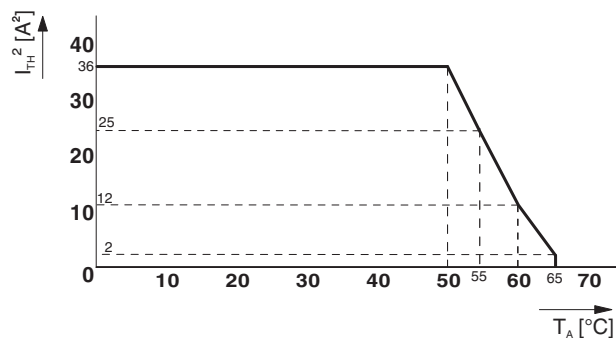

Figure 4 Derating curve - mounting position with module front at the top and aligned modules

Expanded ambient temperature range (with no distance): up to +70 °C

Conditions:

Max. rated control supply voltage	24 V DC
Max. total current of the enabling current path	250 mA ²

8 Load curve

8.1 Ohmic load

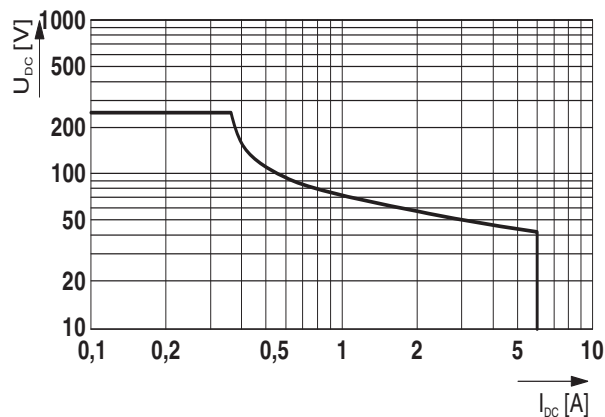

Figure 5 Relay load curve - ohmic load

9 Operating and indication elements

9.1 Connection versions

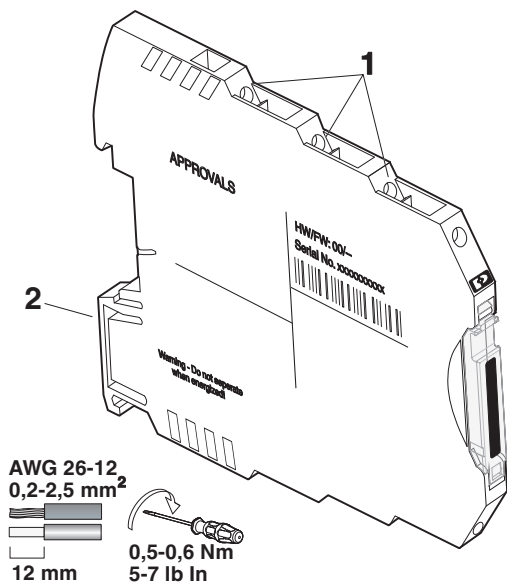

Figure 6 Connection versions

- 1 Fixed screw connection
- 2 Snap-on foot for DIN rail mounting



The year the device was constructed can be found underneath the CE designation on the housing.

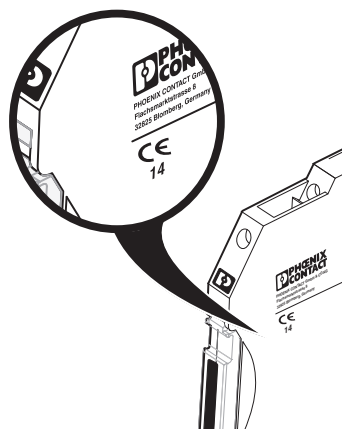

Figure 7 Year of manufacture of the device

9.2 Connection assignment

Figure	Designation	Explanation
	22	Diagnostic output +24 V
	21	+24 V diagnostics input
	A2	0 V (GND)
	A1	+24 V control input with active error acknowledgment
	PWR	Power LED (yellow)
	K1/2	Status indicator safety circuit; LED (green)
	ERR	Error LED (red)
	DGN	Diagnostics LED (green)
	PS 20	
	13/14	Enabling current path, undelayed
	1 3	M1 Signal output (PNP)
	1 4	
	M 1	

10 Mounting and connection

Mount the module on a 35 mm DIN rail according to EN 60715.

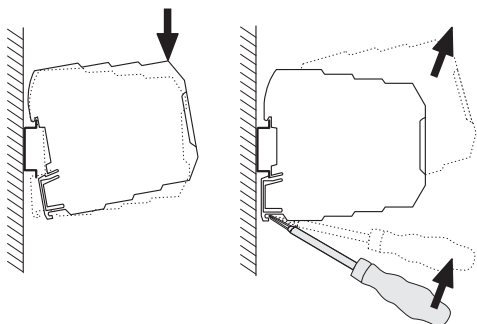

Figure 8 Mounting and removing

Connect the cables to the connection terminal blocks using a screwdriver.

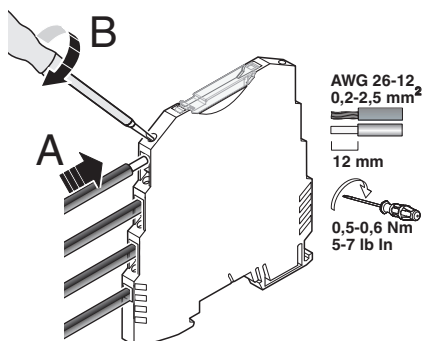

Figure 9 Connection of the cables



For compliance with UL approval, use copper wire that is approved up to 60°C/75°C.

12 Proof test

In the proof test, you check the individual relay channels.

1. Deactivate A1/A2.
2. Apply the 24 V DC diagnosis power supply to contact 21.

If the green DGN-LED lights up, the module is functional.
(Apply 24 V DC to signal output M1.)

If the red ERR LED lights up, replace the module.
(Apply 0 V DC to signal output M1. Error acknowledgment via A1 is inactive.)

If the diagnostic voltage supply is present and the green DGN LED and the red ERR LED are on, replace the module.

If the diagnostic voltage supply is present but **neither** of the LEDs specified is on, replace the module.



Replace the device in the event of an error.

11 Startup

Apply the rated control supply voltage to terminals A1/A2.
The PWR LED and K1/2 LED light up.

Enabling current path 13/14 closes, and confirmation current path 21/22 opens.

13 Calculating the power dissipation



The total power dissipation of the safety relay is based on the input power dissipation and the contact power dissipation for the same and for different load currents.

Input power dissipation

$$P_{\text{Input}} = U_B^2 / (U_S / I_S)$$

Contact power dissipation

With the same load currents:

$$P_{\text{Contact}} = n \cdot I_L^2 \cdot 50 \text{ m}\Omega$$

With different load currents:

$$P_{\text{Contact}} = (I_{L1}^2 + I_{L2}^2 + \dots + I_{Ln}^2) \cdot 50 \text{ m}\Omega$$

Total power dissipation

$$P_{\text{Total}} = P_{\text{Input}} + P_{\text{Contact}}$$

therefore

$$P_{\text{Total}} = U_B^2 / (U_S / I_S) + n \cdot I_L^2 \cdot 50 \text{ m}\Omega$$

or

$$P_{\text{Total}} = U_B^2 / (U_S / I_S) + (I_{L1}^2 + I_{L2}^2 + \dots + I_{Ln}^2) \cdot 50 \text{ m}\Omega$$

Key:

Designation	Explanation
P	Power dissipation in mW
U_B	Applied operating voltage
U_S	Rated control supply voltage
I_S	Rated control supply current
n	Number of enabling current paths used
I_L	Contact load current

14 Application examples

Key:

- SIS = Safety Instrumented System (safe control)
- DC = Diagnostic Coverage according to IEC 61508 (line/load diagnostics at DO)
- DI = Digital input
- DO = Digital output

Applications with the PSR-PS20

14.1 Application example 1 - SIL 3

- Low-demand application
- Single-channel control
- Diagnostic supply voltage is present

Data for the application example as 1001 structure	
Equipment type	A
HFT	0
SIL	3
SFF	99.66 %
λ_{SD}	0 FIT
λ_{SU}	1579 FIT
λ_{DD}	0 FIT
λ_{DU}	5.392 FIT
λ_{Total}	1584 FIT
MTBF	63 years
PFD_{avg}	2.36×10^{-05} (for $T_1 = 1$ year)

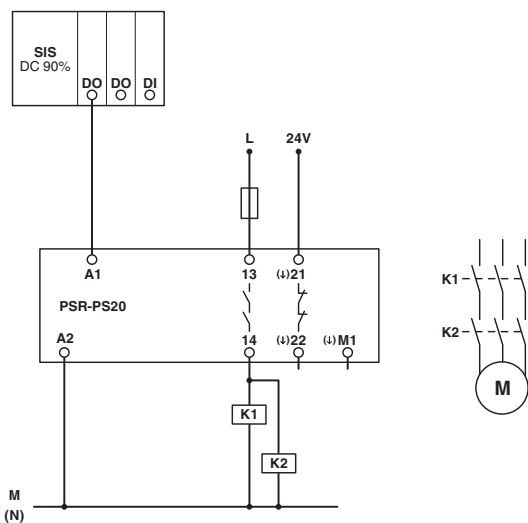

Figure 10 Application example 1 - SIL 3

15 Revision history

Version	Date	Contents
00	2015-03-10	First publication
01	2015-04-29	Info box for application example 1 deleted
02	2015-07-14	Texts / safety notes for ATEX deleted

Компания «Океан Электроники» предлагает заключение долгосрочных отношений при поставках импортных электронных компонентов на взаимовыгодных условиях!

Наши преимущества:

- Поставка оригинальных импортных электронных компонентов напрямую с производств Америки, Европы и Азии, а так же с крупнейших складов мира;
- Широкая линейка поставок активных и пассивных импортных электронных компонентов (более 30 млн. наименований);
- Поставка сложных, дефицитных, либо снятых с производства позиций;
- Оперативные сроки поставки под заказ (от 5 рабочих дней);
- Экспресс доставка в любую точку России;
- Помощь Конструкторского Отдела и консультации квалифицированных инженеров;
- Техническая поддержка проекта, помощь в подборе аналогов, поставка прототипов;
- Поставка электронных компонентов под контролем ВП;
- Система менеджмента качества сертифицирована по Международному стандарту ISO 9001;
- При необходимости вся продукция военного и аэрокосмического назначения проходит испытания и сертификацию в лаборатории (по согласованию с заказчиком);
- Поставка специализированных компонентов военного и аэрокосмического уровня качества (Xilinx, Altera, Analog Devices, Intersil, Interpoint, Microsemi, Actel, Aeroflex, Peregrine, VPT, Syfer, Eurofarad, Texas Instruments, MS Kennedy, Miteq, Cobham, E2V, MA-COM, Hittite, Mini-Circuits, General Dynamics и др.);

Компания «Океан Электроники» является официальным дистрибьютором и эксклюзивным представителем в России одного из крупнейших производителей разъемов военного и аэрокосмического назначения «JONHON», а так же официальным дистрибьютором и эксклюзивным представителем в России производителя высокотехнологичных и надежных решений для передачи СВЧ сигналов «FORSTAR».



JONHON

«JONHON» (основан в 1970 г.)

Разъемы специального, военного и аэрокосмического назначения:

(Применяются в военной, авиационной, аэрокосмической, морской, железнодорожной, горно- и нефтедобывающей отраслях промышленности)

«FORSTAR» (основан в 1998 г.)

ВЧ соединители, коаксиальные кабели, кабельные сборки и микроволновые компоненты:

(Применяются в телекоммуникациях гражданского и специального назначения, в средствах связи, РЛС, а так же военной, авиационной и аэрокосмической отраслях промышленности).



Телефон: 8 (812) 309-75-97 (многоканальный)

Факс: 8 (812) 320-03-32

Электронная почта: ocean@oceanchips.ru

Web: <http://oceanchips.ru/>

Адрес: 198099, г. Санкт-Петербург, ул. Калинина, д. 2, корп. 4, лит. А