

Lithium-ion Battery Charger Controller IC with Timer

■GENERAL DESCRIPTION

The **NJW4100** is a Lithium-ion Battery Charger Controller IC with over charger timer.

Charger current and voltage can individually be set by the external resistors. Therefore, it can be used for a wide range of battery cells for both 1-cell and 2-cell applications.

It includes a lot of safety features for safety conscious design: Over voltage, Over discharge, temperature monitor and over charge timers.

■PACKAGE OUTLINE

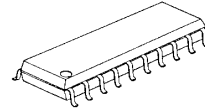

NJW4100M

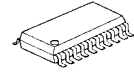

NJW4100V

■FEATURES

- Adjustable Charge Voltage
- Adjustable Pre-Charge and Full Charge Current
- Temperature Monitor
- Over Charge Timer
- Internal Re-Charge function
- Delay timers and Hysteresis inputs for high noise immunity
- Over Discharge Battery Detect
- Over Voltage Protection
- Bi-CMOS Technology
- Package Outline

NJW4100M : DMP20

NJW4100V : SSOP20

■PIN CONFIGURATION

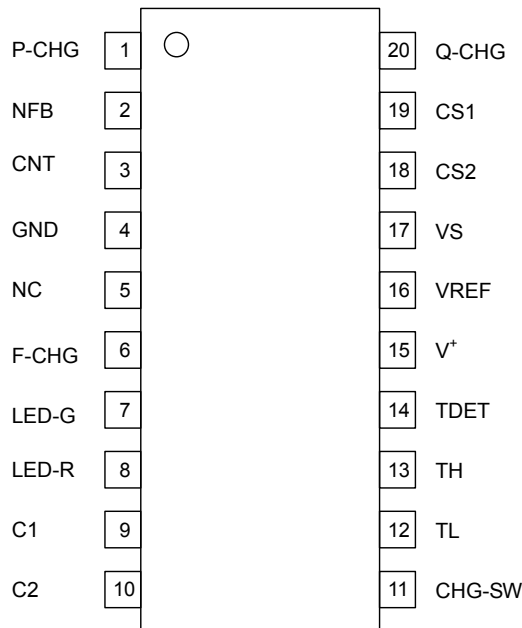

NJW4100M

NJW4100V

NJW4100

■ABSOLUTE MAXIMUM RATINGS (Ta=25°C)

PARAMETER	SYMBOL	MAXIMUM RATINGS	UNIT
Operating Voltage	V ⁺	+15	V
C1 Pin Voltage	V _{C1}	+5	V
C2 Pin Voltage	V _{C2}	+5	V
TDET Pin Voltage	V _{TDET}	+5	V
CNT Pin Output Current	I _{SINK-CNT}	50	mA
LED-G Pin Output Current	I _{SINK-G}	20	mA
LED-R Pin Output Current	I _{SINK-R}	20	mA
Power Dissipation	P _D	DMP20 :300 SSOP20 :300	mW
Operating Temperature Range	T _{OPR}	-20 ~ +85	°C
Storage Temperature Range	T _{STG}	-40 ~ +125	°C

■ELECTRICAL CHARACTERISTICS (V⁺=5V, Ta=25°C)

PARAMETER	SYMBOL	TEST CONDITION	MIN.	TYP.	MAX.	UNIT
General Characteristics						
Operating Voltage	V _{OP}		–	–	14	V
Operating Current	I _{CC}	CHG-SW: OPEN	–	2	3	mA
Under Voltage Lockout Block						
ON Threshold Voltage	V _{T-ON}		2.2	2.4	2.6	V
OFF Threshold Voltage	V _{T-OFF}		2.0	2.2	2.4	V
Hysteresis Voltage	V _{HYS}		100	200	300	mV
Reference Voltage Block						
Reference Voltage	V _{REF}	I _{REF} =0mA	1.228	1.24	1.253	V
Load Regulation	ΔV _{REF}	I _{REF} =0mA~1mA	–	–	10	mV
Voltage Detection Block						
Quick Charge Detection Voltage	V _{Q-CHG}	VS: L→H	V _{BAT} x 0.71	V _{BAT} x 0.73	V _{BAT} x 0.75	V
Re-Charge Detection Voltage	V _{R-CHG}	VS: H→L	V _{BAT} x 0.94	V _{BAT} x 0.95	V _{BAT} x 0.96	V
Over Voltage Detection Voltage	V _{OV}	VS: L→H	V _{BAT} x 1.015	V _{BAT} x 1.025	V _{BAT} x 1.035	V
Charge Control Block Reference Voltage	V _{REF-CV}	VS Pin	4.17	4.2	4.23	V
VS Pin Input Bias Current	I _{VS}	VS=4.2V	–	50	500	nA
Battery Connected Detection Voltage	V _{T-TDET}	TDET Pin	–	1.15	–	V
Low Voltage Detection (2mA Charge) Block						
Charge Current	I _{CHG1}	VS=1V	1	2	3	mA
Low Voltage Detection Voltage	V _{LV}	VS: L→H	V _{BAT} x 0.455	V _{BAT} x 0.475	V _{BAT} x 0.495	V

■ ELECTRICAL CHARACTERISTICS ($V^+=5V$, $T_a=25^\circ C$)

PARAMETER	SYMBOL	TEST CONDITION	MIN.	TYP.	MAX.	UNIT
Current Detection Block						
Pre-Charge /Quick Charge Block Voltage Gain	A_{V1}	CS1=3.8V, CS2=3.6V	11.5	12	12.5	dB
Full Charge Block Voltage Gain	A_{V2}	CS2=VS=4.2V, $V_{F-CHG}=96mV$	15.5	18	21	dB
F-CHG Pin Input Voltage Range	V_{F-CHG}	CS2=VS=4.2V	48	–	–	mV
CS1 Pin Input Bias Current	I_{CS1}	CS1=4.2V	–	10	500	nA
CS2 Pin Input Bias Current	I_{CS2}	CS2=4.2V	–	10	500	nA
Output Block						
CNT Pin Saturation Voltage	V_{OL-CNT}	$I_{SINK}=20mA$	–	0.2	0.5	V
CNT Pin Leak Current	$I_{LEAK-CNT}$	$V^+=14V$	–	–	1	μA
LED Out Block						
LED-G Pin Saturation Voltage	V_{OL-G}	$I_{SINK}=10mA$	–	0.2	0.5	V
LED-G Pin Leak Current	I_{LEAK-G}	$V^+=14V$	–	–	1	μA
LED-R Pin Saturation Voltage	V_{OL-R}	$I_{SINK}=10mA$	–	0.2	0.5	V
LED-R Pin Leak Current	I_{LEAK-R}	$V^+=14V$	–	–	1	μA
Timer Block						
OSC1 Timer Error Time	$\Delta T1$	C1=C2=0.01 μF external	-10	–	+10	%
OSC2 Timer Error Time	$\Delta T2$	Not including external deviation	-10	–	+10	%
CHG-SW Block						
ON Threshold Voltage	V_{SW-ON}		–	–	0.25	V
OFF Threshold Voltage	V_{SW-OFF}		1	–	–	V
Pull-up Resistance	$R_{PULL-UP}$		300	500	700	k Ω

NJW4100

■ TYPICAL APPLICATION

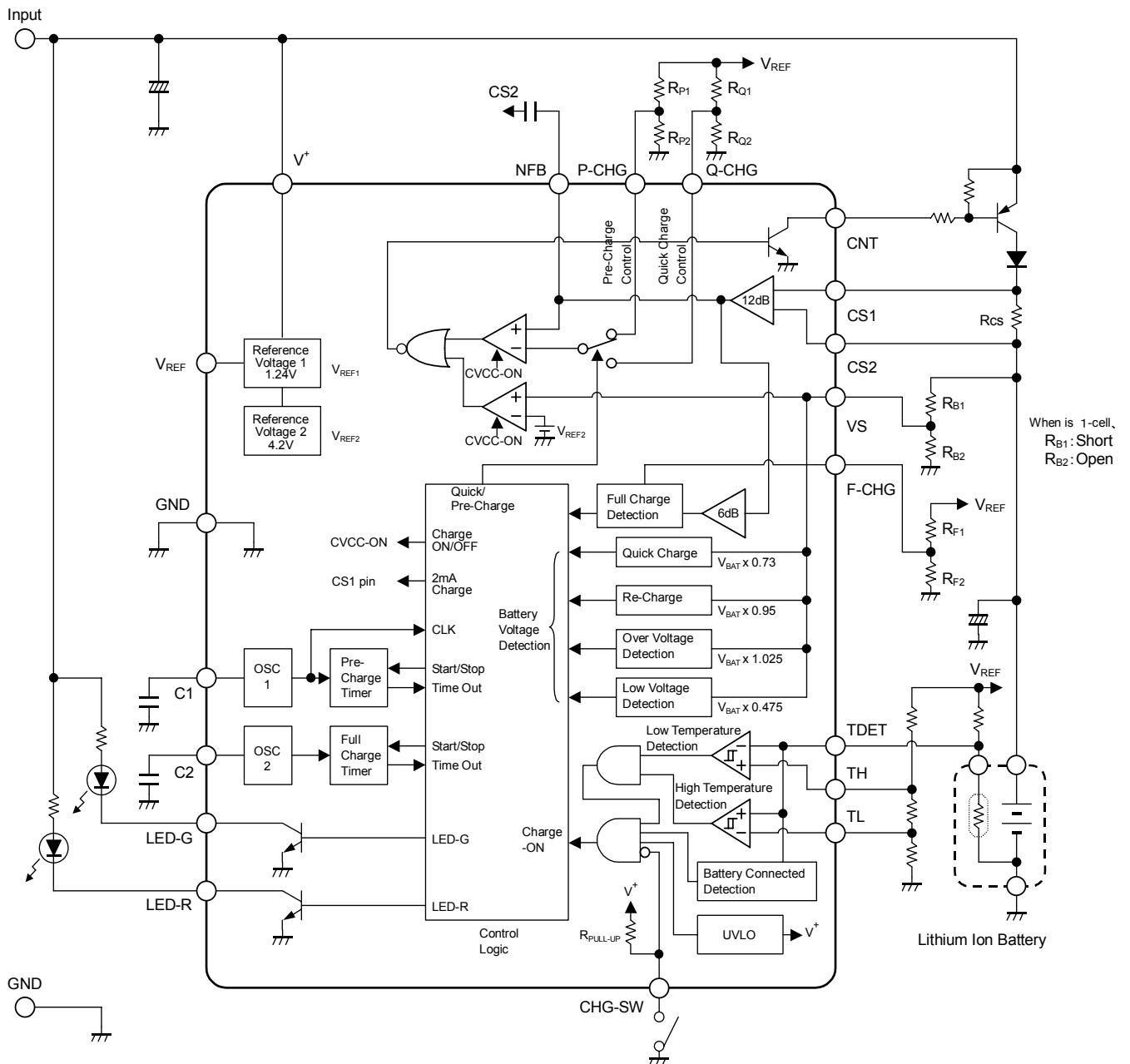

■PIN CONFIGURATION

Pin No.	Pin Name	Function
1	P-CHG	Pre-Charge Current Setting
2	NFB	Current-Regulation-Loop Compensation
3	CNT	Charge Control for Output Pin (External PNP Transistor)
4	GND	GND
5	NC	
6	F-CHG	Full Charge Current Setting
7	LED-G	LED Output
8	LED-R	LED Output
9	C1	Pre-Charge Timer, 2mA Charge Timer, LED Blinking Cycle, Delay Time Setting
10	C2	Quick Timer Setting
11	CHG-SW	Charge ON/OFF Control
12	TL	Batteries Thermal (High Temperature) Setting
13	TH	Batteries Thermal (Low Temperature) Setting
14	TDET	Battery Temperature Detection, Battery Connected Detection
15	V ⁺	Operating Voltage
16	VREF	Reference Voltage Output
17	VS	Battery Voltage Detection
18	CS2	Charge Current Detection 2
19	CS1	Charge Current Detection 1
20	Q-CHG	Quick Charge Current Setting

■CHARGE VOLTAGE / CURRENT for RESISTANCE SETTING

Parameter	Calculation formula	Examples of calculation	
Charge Control Voltage	$V_{BAT} = \frac{RB1 + RB2}{RB2} \times V_{REF-CV(4.2V)}$	4.2V	8.4V
Low Voltage Detection Voltage	$V_{BAT} \times 0.475$	2.00V	3.99V
Quick Charge Start Voltage	$V_{BAT} \times 0.73$	3.07V	6.13V
Re-Charge Detection Voltage	$V_{BAT} \times 0.95$	3.99V	7.98V
Over Voltage Detection Voltage	$V_{BAT} \times 1.025$	4.305V	8.61V
Pre-Charge Current	$I_{P-CHG} = \left(\frac{RP2}{RP1 + RP2} \times V_{REF(1.24V)} / 4 \right) / R_{CS}$ (at. $R_{P1}:232k\Omega$, $R_{P2}:16k\Omega$, $R_{CS}=0.2\Omega$)	100mA	
Quick Charge Current	$I_{Q-CHG} = \left(\frac{RQ2}{RQ1 + RQ2} \times V_{REF(1.24V)} / 4 \right) / R_{CS}$ (at. $R_{Q1}:128k\Omega$, $R_{Q2}:120k\Omega$, $R_{CS}=0.2\Omega$)	750mA	
Full Charge Current	$I_{F-CHG} = \left(\frac{RF2}{RF1 + RF2} \times V_{REF(1.24V)} / 8 \right) / R_{CS}$ (at. $R_{F1}:114.4k\Omega$, $R_{F2}:9.6k\Omega$, $R_{CS}=0.2\Omega$)	60mA	

■ TYPICAL CHARACTERISTICS

Charge Control Block Reference Voltage vs. Temperature ($V^+=5V$, VS Pin)

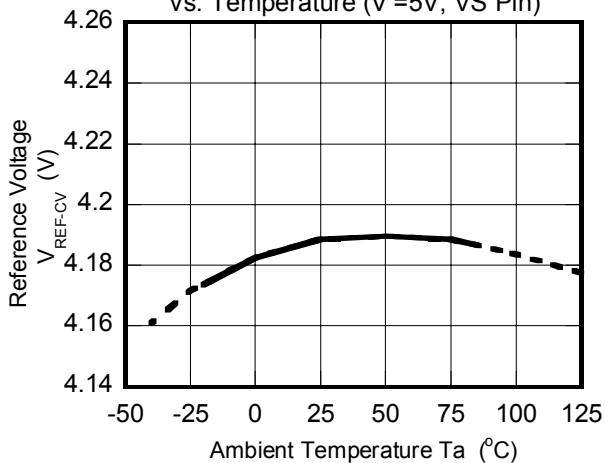

Reference Voltage vs. Temperature ($V^+=5V$, $I_{REF}=0mA$)

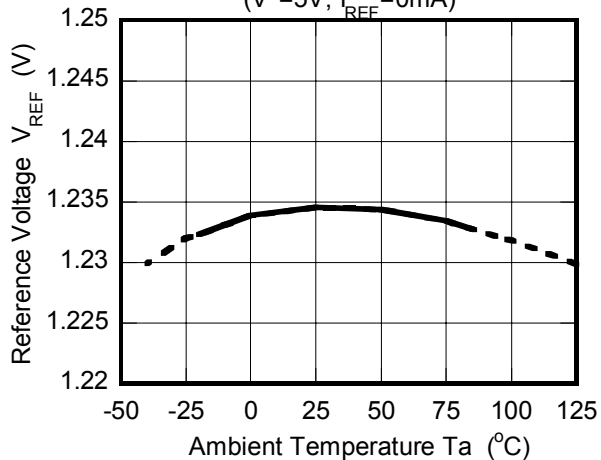

Pre-Charge/Quick Charge Block Voltage Gain vs. Temperature ($V^+=5V$, CS1=3.8V, CS2=3.6V)

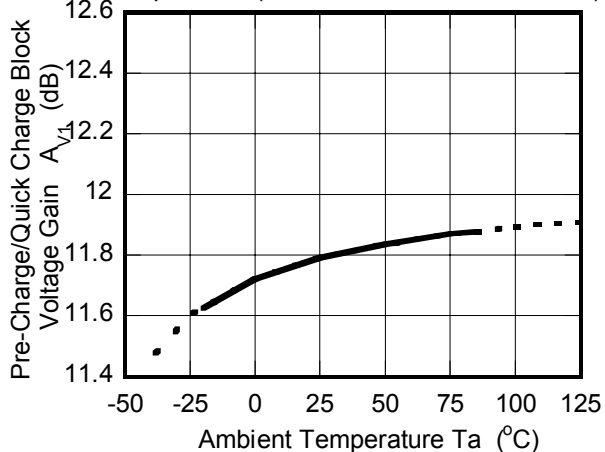

CHG-SW Block Threshold Voltage vs. Temperature ($V^+=5V$)

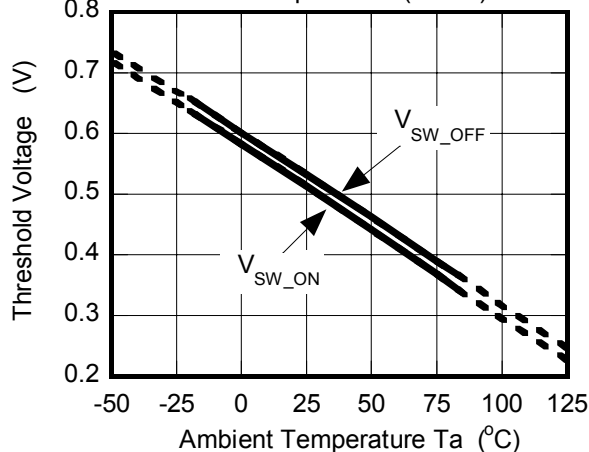

Operating Current vs. Temperature ($V^+=5V$, CHG-SW:OPEN)

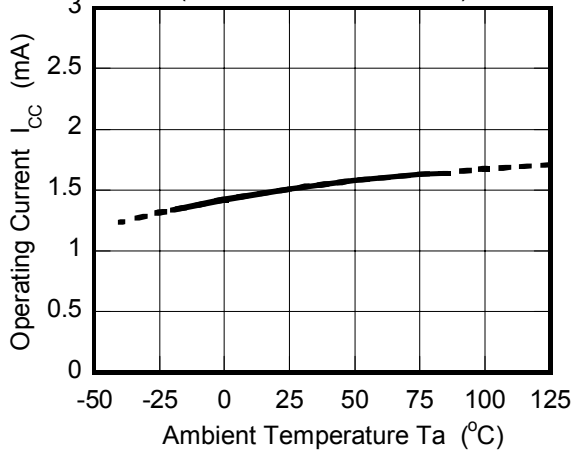

■ TYPICAL CHARACTERISTICS

CNT Pin Saturation Voltage vs. Sink Current

($V^+=5V$, $T_a=25^\circ C$)

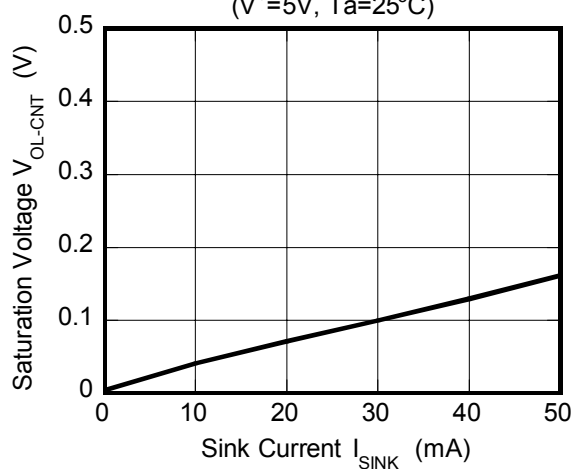

LED Pin Saturation Voltage vs. Sink Current

($V^+=5V$, $T_a=25^\circ C$)

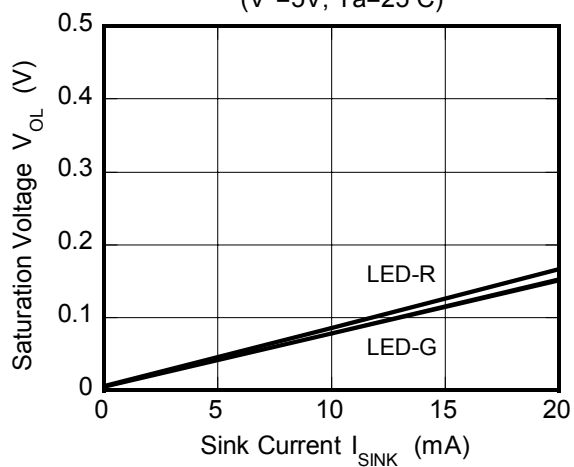

Oscillation Cycle vs. Capacitance

($V^+=5V$, $T_a=25^\circ C$)

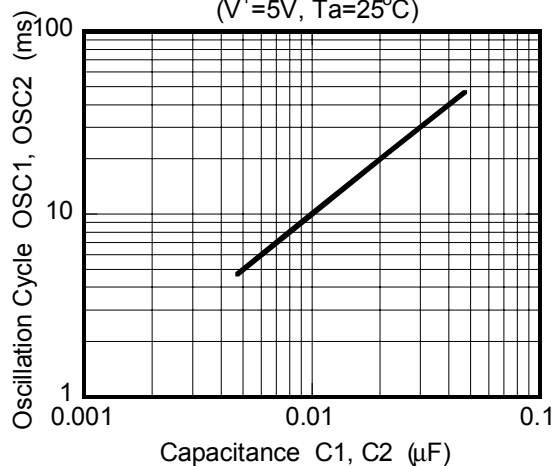

Oscillation Cycle vs. Temperature

($V^+=5V$, $C1=C2=0.01\mu F$)

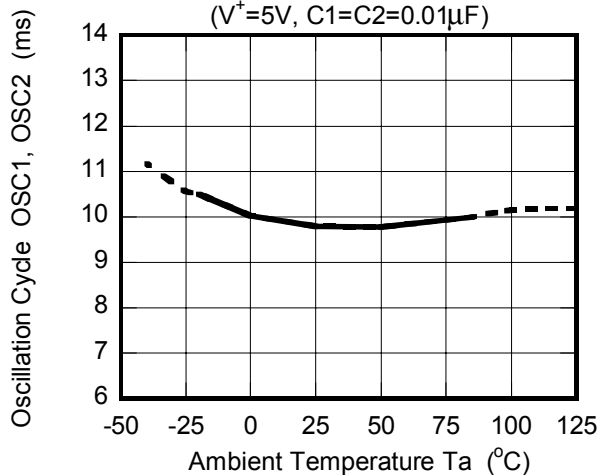

FEATURE DESCRIPTION

1. Voltage Detection Block (VS pin)

The VS pin determines charge voltage, low voltage, over voltage, and re-charge voltage. Battery voltage conditions are constantly monitored. (Figure 1)

1-1. Charge Voltage (VS pin)

Charge voltage V_{BAT} is set using the VS pin external resistors R_{B1} and R_{B2} and the following equation:

$$V_{BAT} = \frac{R_{B1} + R_{B2}}{R_{B2}} \times V_{REF-CV(4.2V)}$$

Using the following settings makes it easy to support applications for one or two cells: for one cell, R_{B1} = short, and R_{B2} = open;

for two cells, $R_{B1}=R_{B2}$. If you use a high resistance, the VS pin's bias current will cause incorrect values. Use as low a resistance as possible.

1-2. Overcharge Detection Block (VS pin)

The overcharge detection block stops charging when a high voltage is detected at the VS pin.

The overcharge detection voltage is obtained with the following equation:

$$V_{OV} = V_{BAT} \times 1.025 \text{ (typ.)}$$

When overcharge is detected, charging is prohibited and LED-R blinks. After that, charge will continue to be prohibited, even after battery voltage drops to a normal value. Turning the power off to release UVLO, battery connection detection, or CHG-SW switching will enable the charge sequence to restart.

1-3. Low Voltage Detection (2mA charge) Block (VS pin, CS1 pin)

The low voltage detection block detects an over-discharged battery, or an open battery caused by the battery protection circuit or the like. This will determine a 2mA charge prior to pre-charging.

The low voltage detection voltage is obtained with the following equation:

$$V_{LV} = V_{BAT} \times 0.475 \text{ (typ.)}$$

During a 2mA charge, the block monitors battery voltage recovery while a steady 2mA current is output from the CS1 pin. (Figure 2)

If voltage does not recover within a prescribed time, the timer will prohibit 2mA charging. Turning the power off to release UVLO, battery connection detection, or CHG-SW switching will enable the charge sequence to restart.

1-4. Re-Charge Detection (VS pin)

When a fully charged battery is left for a long period of time, voltage will drop due to self-discharge. The re-charge detection block detects a drop in voltage and re-charges the battery.

The re-charge detection voltage is obtained with the following equation.

$$V_{R-CHG} = V_{BAT} \times 0.95 \text{ (typ.)}$$

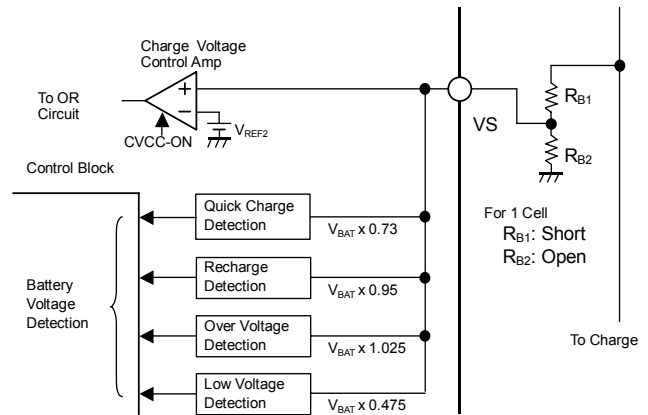

Figure 1. Voltage Detection Block Configuration

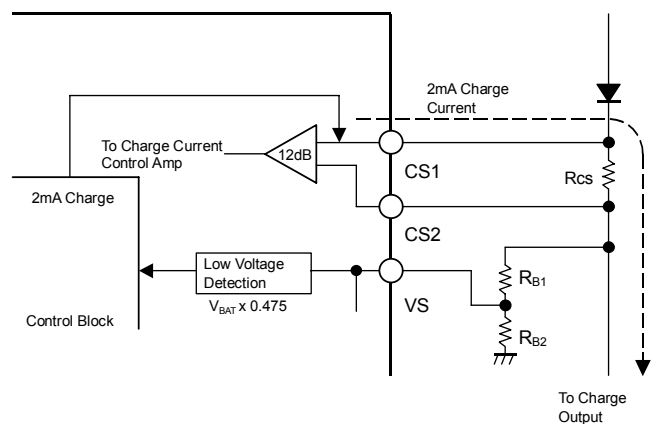

Figure 2. 2mA Charging Block

FEATURE DESCRIPTION (CONTINUED)

2. Current Detection Block (CS1 pin, CS2 pin)

A current detection resistor R_{CS} is inserted between pin CS1 and pin CS2 to monitor battery charge current.

The input voltage between pin CS1 and pin CS2 is amplified by the 12dB current detection amp and fed back to the charge current control amp. (Figure 3)

2-1. Pre-Charge Current, Quick Charge Current (P-CHG pin, Q-CHG pin)

This will switch between charging with pre-charge current or quick charge current according to the level of the battery voltage V_{BAT} that is input from the VS pin.

$V_{BAT} \times 0.475$ to $V_{BAT} \times 0.73$	Pre-charge control
$V_{BAT} \times 0.73$ to V_{BAT}	Quick charge control

Pre-charge and quick charge current values are determined by the P-CHG pin and the Q-CHG pin voltage settings. Settings are made according to the following formulae.

Pre-Charge Current Value

$$I_{P-CHG} = \left(\frac{R_{P2}}{R_{P1} + R_{P2}} \times V_{REF(1.24V)} / 4 \right) / R_{CS}$$

Quick Charge Current Value

$$I_{Q-CHG} = \left(\frac{R_{Q2}}{R_{Q1} + R_{Q2}} \times V_{REF(1.24V)} / 4 \right) / R_{CS}$$

2-2. Full Charge Detection (F-CHG pin)

Charge termination is determined by a set full charge current I_{F-CHG} , which is determined by a voltage setting on the F-CHG pin.

$$I_{F-CHG} = \left(\frac{R_{F2}}{R_{F1} + R_{F2}} \times V_{REF(1.24V)} / 8 \right) / R_{CS}$$

When charging is terminated, LED-G turns on, and the sequence moves to the re-charge detection operation.

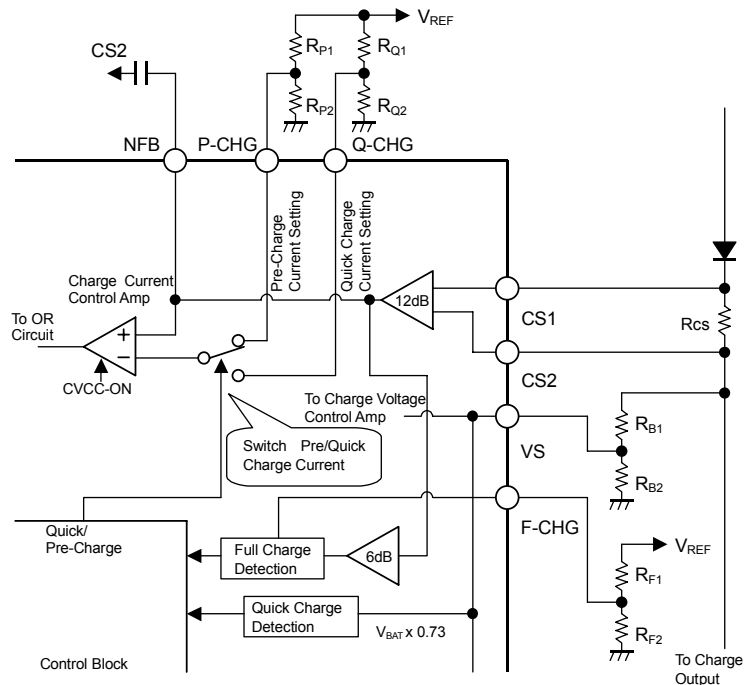

Figure 3. Block for Controlling Pre-Charge, Quick Charge, and Block for Detecting Full Charge.

■FEATURE DESCRIPTION (CONTINUED)

3. Charge Control Output Block (CNT pin)

A PNP transistor connected to the CNT pin controls the voltage and current required to charge the battery. When the CHG-SW pin and battery-connected detection are both ON the system moves to charge control mode. If battery voltage and temperature conditions are appropriate, charging will begin. During 2mA charging the PNP transistor will go to OFF status.

4. Temperature Detection Block, Battery Connected Detection Block (TDET pin, TH pin, TL pin)

The charge temperature range is set with the TL pin (high temperature) and the TH pin (low temperature). The threshold voltage for the temperature detection comparator is set with the external resistors R_{THL} , R_{TH} , R_{TL} . Therefore, you can select any type of thermistor (NTC) and any charge temperature range (Figure 4).

The TL pin and the TH pin are set to go to the potential states shown below for fluctuations in TDET voltage.
 V_{TL} (high temperature) < V_{TDET} (charge Temperature) < V_{TH} (low temperature)

Pin voltages are obtained from the following formulae.

TDET pin (thermistor setting)

$$V_{TDET} = \frac{R_T}{R_{TDET} + R_T} \times V_{REF(1.24V)}$$

TH pin (low temperature setting)

$$V_{TH} = \frac{R_{TH} + R_{TL}}{R_{THL} + R_{TH} + R_{TL}} \times V_{REF(1.24V)}$$

TL pin (high temperature setting)

$$V_{TL} = \frac{R_{TL}}{R_{THL} + R_{TH} + R_{TL}} \times V_{REF(1.24V)}$$

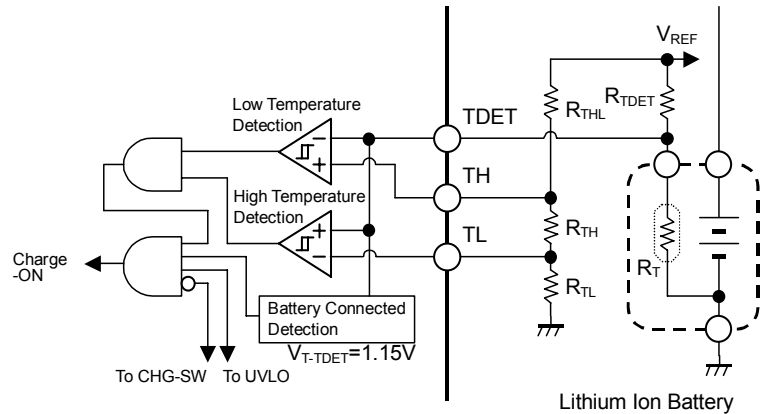

Figure 4 Temperature Detection Block

When the detected temperature goes out of the range of the set values, charging stops, and LED-R and LED-G turn off. After temperature is restored, charging recommences in line with battery voltage status.

The TDET pin is also used for the battery-connected detection feature.

The battery-connected detection feature determines that a battery is connected if TDET pin voltage is no greater than 1.15V(typ.), and commences charging.

■FEATURE DESCRIPTION (CONTINUED)

5. Delay Circuits (each detection block)

Each detection block has a delay circuit and extra features for preventing malfunction due to noise or excess signals.

Table 1 Delay Circuits and Extra Features.

Detection Block	Delay Circuit	Extra Feature
Low Voltage Malfunction Prevention Circuit	Delay I	Hysteresis
CHG-SW		Hysteresis
Battery Connected Detection		Hysteresis
Temperature Detection		Hysteresis
Full Charge Detection		–
Re-Charge Detection		–
Low Voltage Detection		Hysteresis
Over Voltage Detection		Latch
Quick Charge Detection	Delay II	Hysteresis

The delay circuit block receives a signal from the timer circuit to fix a delay time.

For details on the relationship between the delay time and capacitors see “6. Timer Circuit Block”.

6. Timer Circuit Block (C1 pin, C2 pin)

OSC1 is used for the timer that is used for pre-charge, 2mA charge and the like. OSC2 is used for the quick charge timer.

You can change the time of the timers with external capacitors. Tables 2, 3 show the relationship between capacitance and time.

Table 2 C1, C2 Oscillation Cycle t

Capacitance (C1, C2)	Oscillation Cycle (OSC1, OSC2)
4700pF	t = 4.7ms
0.01μF	t = 10ms
0.022μF	t = 22ms
0.047μF	t = 47ms

Table 3 Timer Time

Block Name	Parameter	Calculation Formula	Examples	
Pre-Charge Timer	2mA Charge Timer	$t \times 2^{10}$	10.2s	C1=0.01μF
	Pre-Charge Timer	$t \times 2^{17}$	22min.	
	LED R Blinking Cycle	$t \times 2^7$	1.28s	
	Delay I	$t \times 2^5$	0.32s	
	Delay II	$t \times 2^4$	0.16s	
Quick Charge Timer	Quick Charge Timer	$t \times 2^{20}$	2hours 55 min.	C2=0.01μF

Use capacitors that have good temperature characteristics in the OSC block.

Capacitor deviation will cause timer errors.

■FEATURE DESCRIPTION (CONTINUED)

In each charge mode if time-over occurs charging is prohibited and LED-R blinks. Turning the power off to release UVLO, battery connection detection, or CHG-SW switching will enable the charge sequence to restart.

NJW4100 incorporates a test mode that shortens the timer block function's test time by 1/150,000.

To operate in test mode set the TH pin voltage to a value no greater than that of the TL pin. In test mode, regardless of the external timing capacitors C1, C2, the internal timer clock frequency will operate in a range of approximately 200kHz to 300kHz. The following shows calculation values when the oscillating frequency is 250kHz (4μs cycle).

Table 4. Timer Times in Test Mode.

Block Name	Parameter	Calculation Formula	Example (t = Appx. 4μs)
Pre-Charge Timer	2mA Charge Timer	$t \times 2^{10}$	Appx. 4ms
	Pre-Charge Timer	$t \times 2^{17}$	Appx. 0.5s
	LED R Blinking Cycle	$t \times 2^7$	Appx. 0.5ms
	Delay I	$t \times 2^5$	Appx. 0.13ms
	Delay II	$t \times 2^4$	Appx. 64μs
Quick Charge Timer	Quick Charge Timer	$t \times 2^{20}$	Appx. 4.2s

When the TDET pin voltage is approximately 1.2V or greater, the pre-charge / quick charge timers operate normally.

If you want to further reduce the test time, setting TDET pin voltage makes it possible to run each of the timer counters divided in half. When the TDET pin is approximately 0.3V or less, the first half of the counter is bypassed. When the voltage is approximately greater than 0.4V and less than 1.1V, the second half of the counter is bypassed.

Table 5. Reduced Test Time Mode

Parameter	Calculation Formula	Example (t = Appx. 4μs)
Pre-Charge Timer	$t \times 2^8$, $t \times 2^9$	Appx. 1ms, Appx. 1ms
Quick Charge Timer	$t \times 2^9$, $t \times 2^{10}$	Appx. 2ms, Appx. 4ms

■FEATURE DESCRIPTION (CONTINUED)

7. Reference Voltage Block (VREF pin)

This block generates 1.24V and 4.2V reference voltages. The VREF pin outputs 1.24V. In addition to the IC internal reference voltage, this is also used as a reference voltage for charge current setting and temperature detection setting.

8. Power Block, Under Voltage Lockout Circuit (UVLO) Block (V⁺ pin, GND pin)

An integrated Under Voltage Lockout circuit prevents IC malfunction when power is turned on or off. This circuit incorporates a 200mV hysteresis width to prevent chattering.

As required, insert a bypass capacitor near the IC's V⁺ pin when there is power line noise or when wires are long.

9. LED Block (LED-R pin, LED-G pin)

The 2 LEDs can indicate charge status. (Figure 5)

The LED drive circuit is an open collector output configuration.

Therefore, it is easy to set a constant LED drive current with resistance values.

The expression for setting the current that flows through the LEDs is shown below.

$$I_{LED-G} \doteq (V_{CC} - V_{F-LED} - V_{OL-G}) / R_{LED}$$

or

$$I_{LED-R} \doteq (V_{CC} - V_{F-LED} - V_{OL-R}) / R_{LED}$$

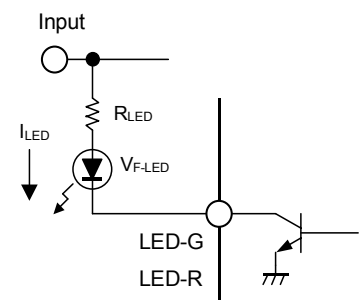
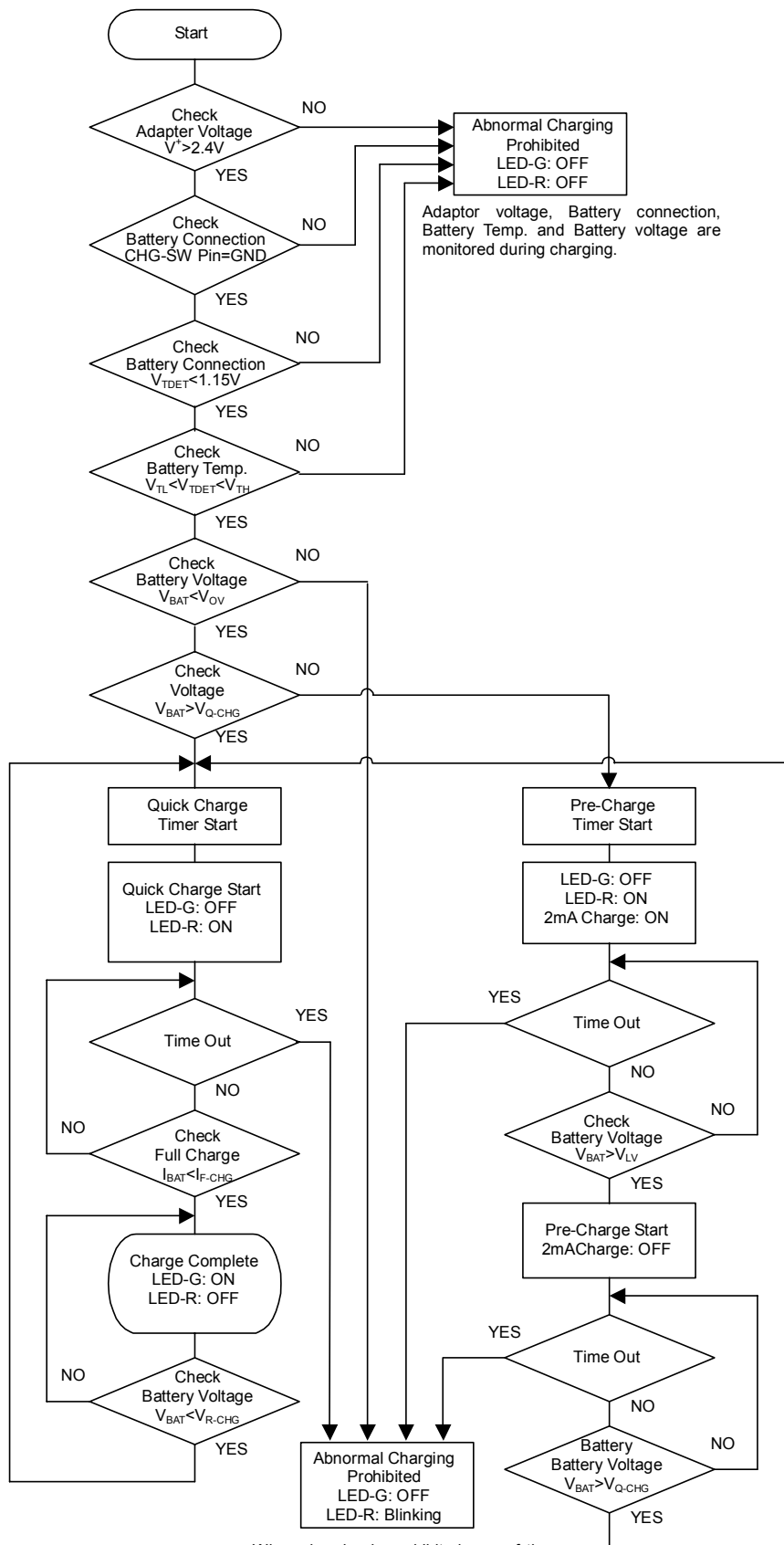

Figure 5. LED Drive Circuit

■FLOW CHART



When charging is prohibited, one of the following action resumes the charging;
 Unplug and plug power supply
 Remove and set batteries
 Charge-SW ON/OFF

■TIMING CHART

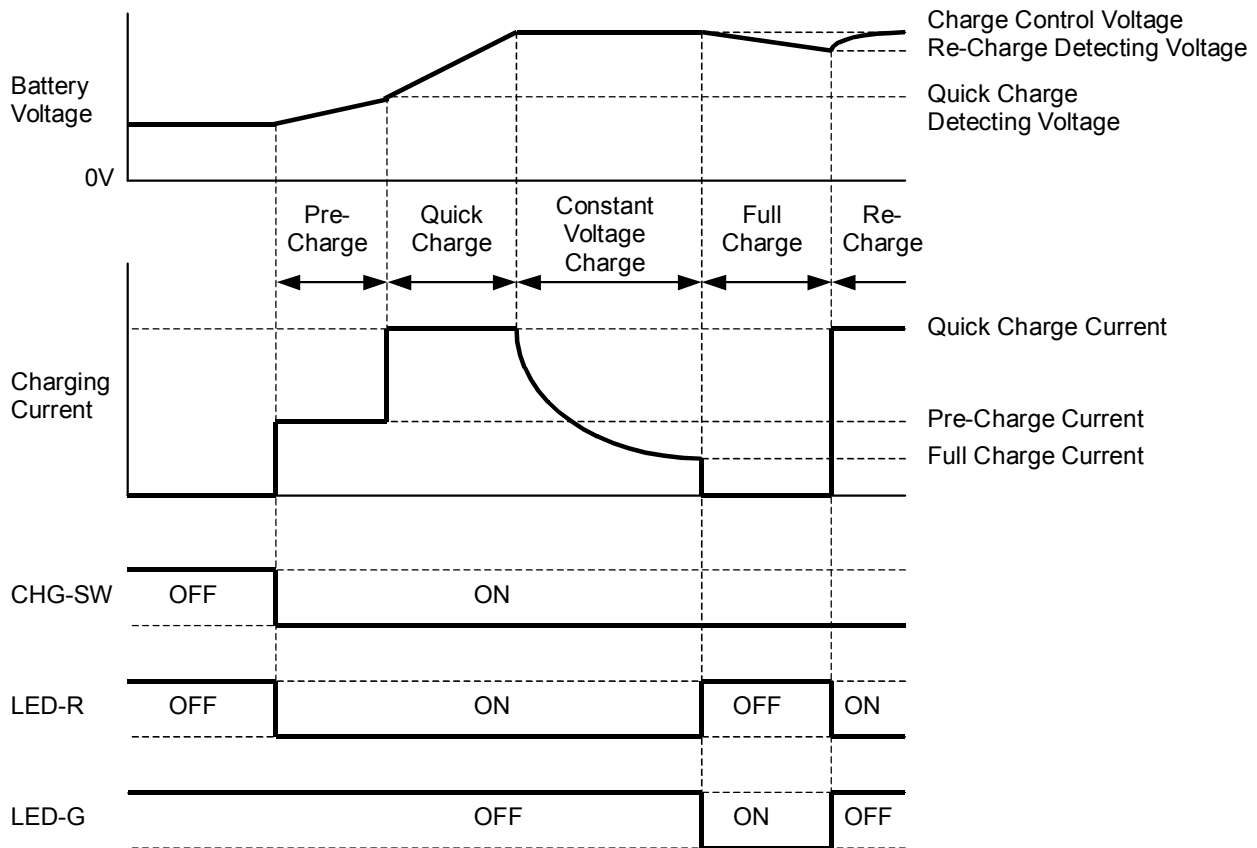

■The timing chart at the time of protection circuit operation

In addition to a charge timing chart, a protection circuit with a built-in IC operates according to the state and circumference environment of a battery.

The timing chart when various protection circuits operate is as follows.

●Pre-charge time out

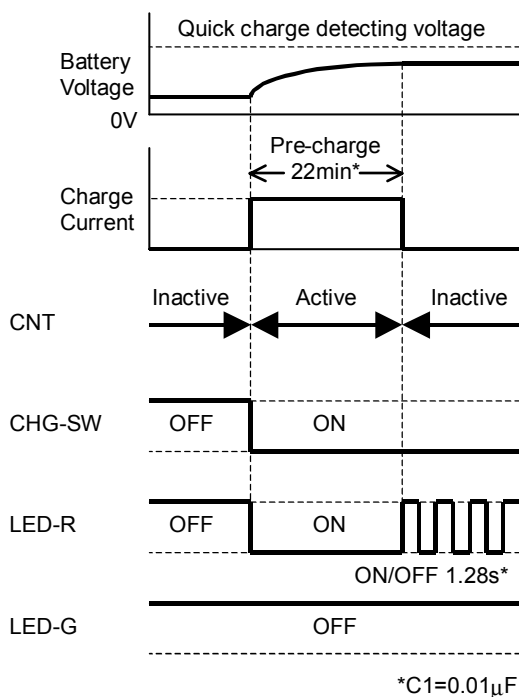

●Quick charge time out

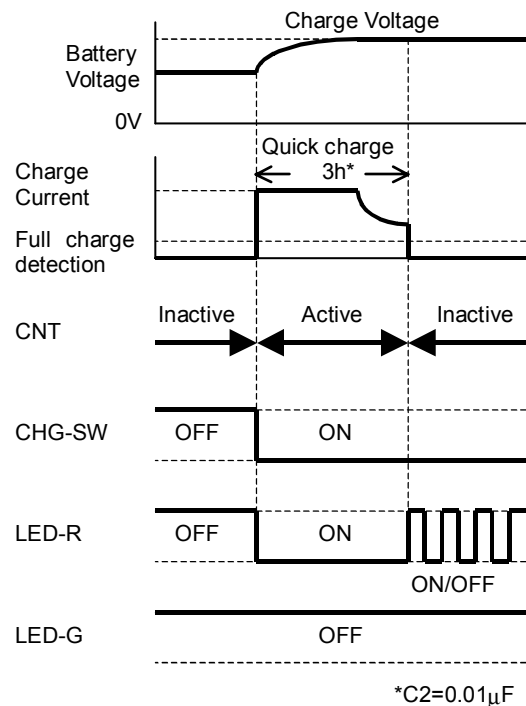

●Low voltage battery (Return)

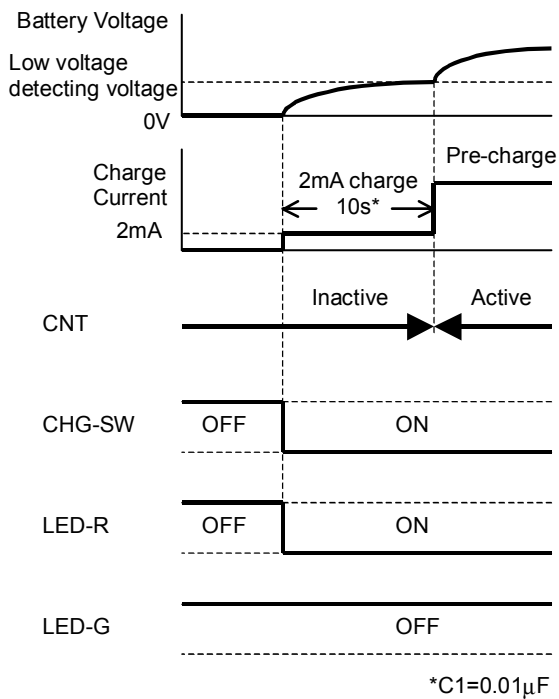

●Low voltage battery (Abnormalities)

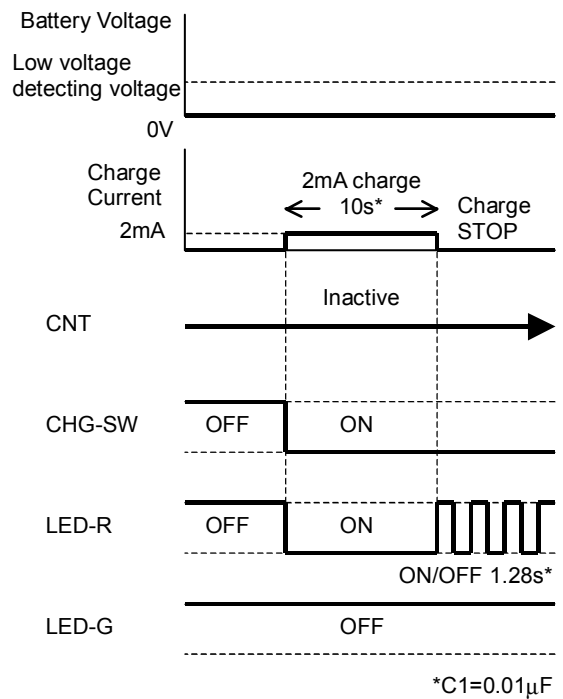

●Over charge battery

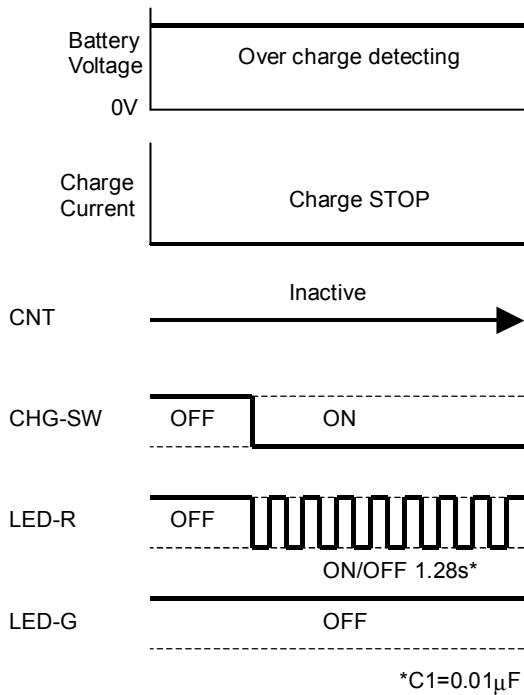

●Abnormalities in temperature

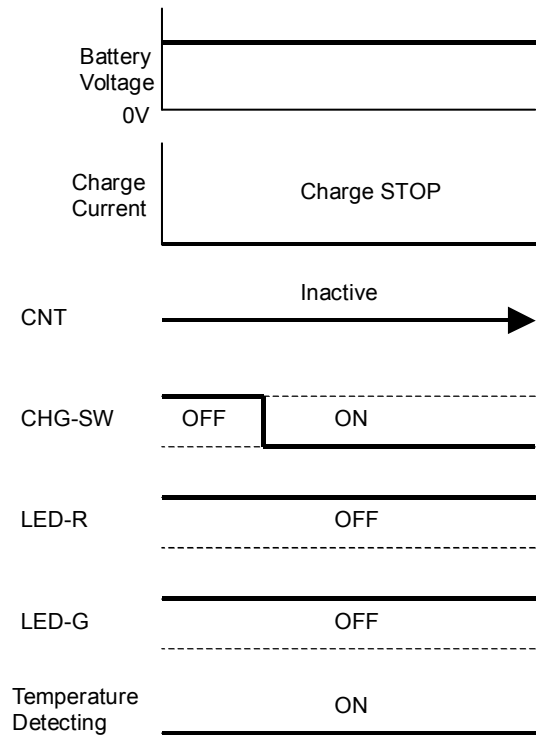

■OPERATION MATRIX

Parameter	Battery Un-connecting	Quick Charge	Pre-Charge	2mA Charge	Full Charge	Abnormal Temperature	Over Voltage Error	Time OUT
LED-G	OFF	OFF	OFF	OFF	ON	OFF	OFF	OFF
LED-R	OFF	ON	ON	ON	OFF	OFF	Blinking	Blinking
Tr.	OFF	ON	ON	OFF	OFF	OFF	OFF	OFF
Charge Current	-	Q-CHG	P-CHG	2mA	-	-	-	-
Return Charge	-	-	-	-	Re-Charge	Auto	Latch	Latch
Timer	Stop	Operate	Operate	Operate	Stop	Stop	Stop	-
Temperature Detecting	Disregard	Operate	Operate	Operate	Operate	-	Operate	Operate
Over Voltage Detecting	Disregard	Operate	Operate	Operate	Operate	Operate	-	Operate
CHG-SW	Stay	Operate	Operate	Operate	Operate	Re-start	Re-start	Re-start
Battery Setting	Stay	Operate	Operate	Operate	Operate	Re-start	Re-start	Re-start
Full Charge Detecting	Disregard	Operate	Stop	Disregard	-	Disregard	Disregard	Disregard

Disregard: Detection function is not reflected in control although it is operating.

■LED ON/OFF PATTERN

Parameter	NJW4100		NJW4101*		NJW4102*		NJW4103*	
	LED-R	LED-G	LED-R	LED-G	LED-R	LED-G	LED-R	LED-G
Adaptor Voltage Detecting	OFF	OFF	OFF	OFF	ON	OFF	ON	OFF
Charging	ON	OFF	ON	OFF	ON	BLINKING	ON	BLINKING
Full Charging	OFF	ON	OFF	ON	ON	ON	ON	ON
Temperature Error	OFF	OFF	BLINKING	OFF	OFF	OFF	BLINKING	OFF
Over Voltage Detecting	BLINKING	OFF	BLINKING	OFF	BLINKING	OFF	BLINKING	OFF
Time Out	BLINKING	OFF	BLINKING	OFF	BLINKING	OFF	BLINKING	OFF

*Available upon request.

NJW4100

■The example of application

●Specification

Input Voltage	:more than 5V	Charge Battery	:Lithium-ion Battery 1cell
Charge Control Voltage	:4.2V	Quick Charge Start Voltage	:3.07V
Pre-Charge Current	:100mA	Re-Charge Detection Voltage	:3.99V
Quick Charge Current	:750mA	Over Voltage Detection Voltage	:4.305V
Full Charge Current	:60mA		

Charge Temperature Range : 0°C~45°C (thermistor :10kΩ, B value 3435)

●The example of application circuit

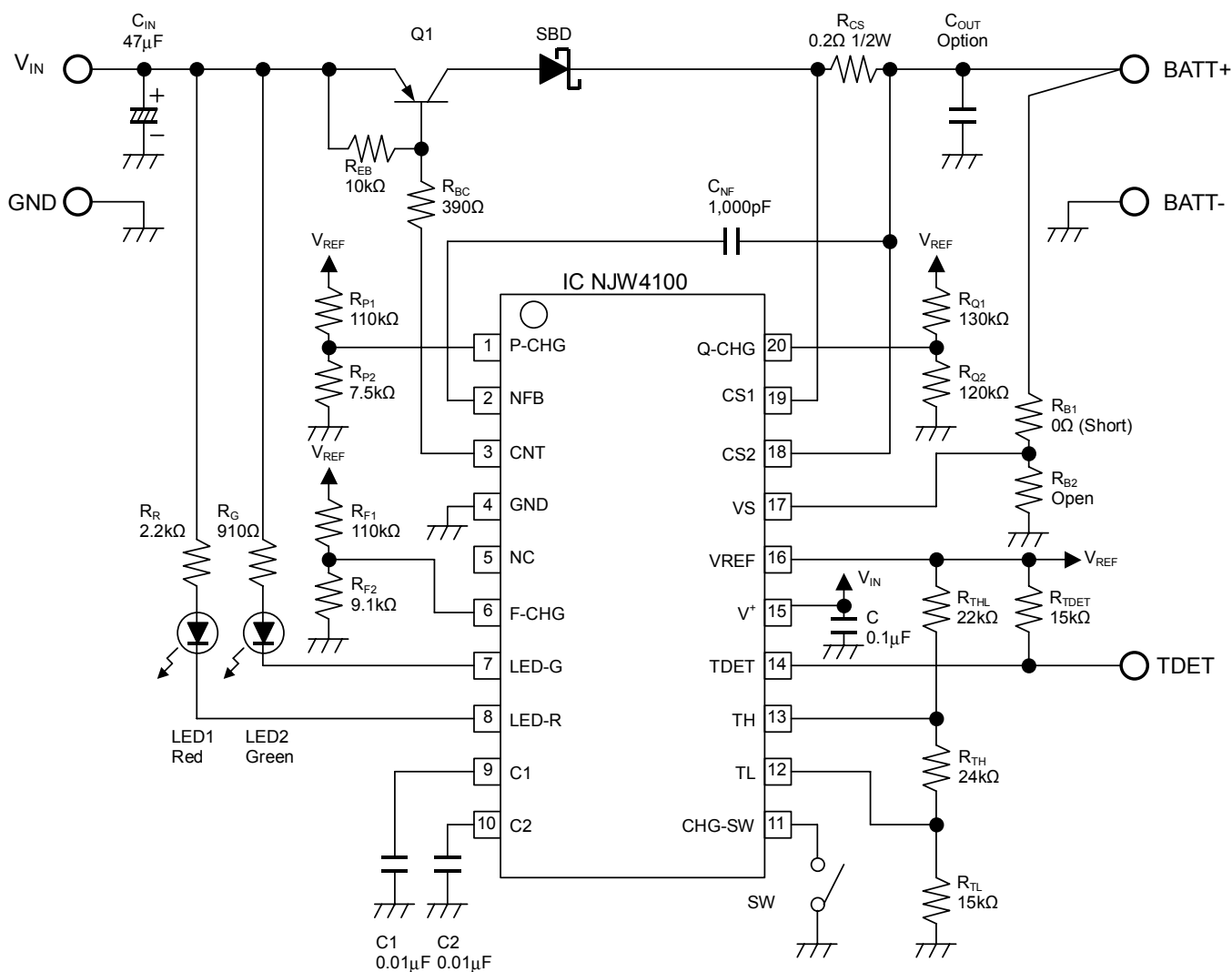

Q1	: 2SA1244	(Toshiba)
SBD	: EC30LA02	(Nihon Inter)
R _{CS}	: RL1632R-R200-F	(Susumu)
C _{IN}	: MVS16VC47MF46	(Nippon chemi-con)

MEMO

[CAUTION]
The specifications on this databook are only given for information, without any guarantee as regards either mistakes or omissions. The application circuits in this databook are described only to show representative usages of the product and not intended for the guarantee or permission of any right including the industrial rights.

Mouser Electronics

Authorized Distributor

Click to View Pricing, Inventory, Delivery & Lifecycle Information:

[NJR:](#)

[NJW4100M](#) [NJW4100M-TE1](#) [NJW4100V-TE1](#)

Компания «Океан Электроники» предлагает заключение долгосрочных отношений при поставках импортных электронных компонентов на взаимовыгодных условиях!

Наши преимущества:

- Поставка оригинальных импортных электронных компонентов напрямую с производств Америки, Европы и Азии, а так же с крупнейших складов мира;
- Широкая линейка поставок активных и пассивных импортных электронных компонентов (более 30 млн. наименований);
- Поставка сложных, дефицитных, либо снятых с производства позиций;
- Оперативные сроки поставки под заказ (от 5 рабочих дней);
- Экспресс доставка в любую точку России;
- Помощь Конструкторского Отдела и консультации квалифицированных инженеров;
- Техническая поддержка проекта, помощь в подборе аналогов, поставка прототипов;
- Поставка электронных компонентов под контролем ВП;
- Система менеджмента качества сертифицирована по Международному стандарту ISO 9001;
- При необходимости вся продукция военного и аэрокосмического назначения проходит испытания и сертификацию в лаборатории (по согласованию с заказчиком);
- Поставка специализированных компонентов военного и аэрокосмического уровня качества (Xilinx, Altera, Analog Devices, Intersil, Interpoint, Microsemi, Actel, Aeroflex, Peregrine, VPT, Syfer, Eurofarad, Texas Instruments, MS Kennedy, Miteq, Cobham, E2V, MA-COM, Hittite, Mini-Circuits, General Dynamics и др.);

Компания «Океан Электроники» является официальным дистрибьютором и эксклюзивным представителем в России одного из крупнейших производителей разъемов военного и аэрокосмического назначения «JONHON», а так же официальным дистрибьютором и эксклюзивным представителем в России производителя высокотехнологичных и надежных решений для передачи СВЧ сигналов «FORSTAR».



JONHON

«JONHON» (основан в 1970 г.)

Разъемы специального, военного и аэрокосмического назначения:

(Применяются в военной, авиационной, аэрокосмической, морской, железнодорожной, горно- и нефтедобывающей отраслях промышленности)

«FORSTAR» (основан в 1998 г.)

ВЧ соединители, коаксиальные кабели, кабельные сборки и микроволновые компоненты:

(Применяются в телекоммуникациях гражданского и специального назначения, в средствах связи, РЛС, а так же военной, авиационной и аэрокосмической отраслях промышленности).



Телефон: 8 (812) 309-75-97 (многоканальный)

Факс: 8 (812) 320-03-32

Электронная почта: ocean@oceanchips.ru

Web: <http://oceanchips.ru/>

Адрес: 198099, г. Санкт-Петербург, ул. Калинина, д. 2, корп. 4, лит. А