

### Revision Control Record

Rev.	Description of Change	ECN No.	Date
<b>D</b>	NOTES & VIEW	03189	5/29/03
<b>E</b>	CAP COLOR TO RED	03257	7/15/03
<b>F</b>	DIMENSIONS & VIEW	03733	12/23/03

(F) 1"-11 1/2 NPSM  
CONDUIT LOCKNUT  
(POINTS TOWARD FLANGE)

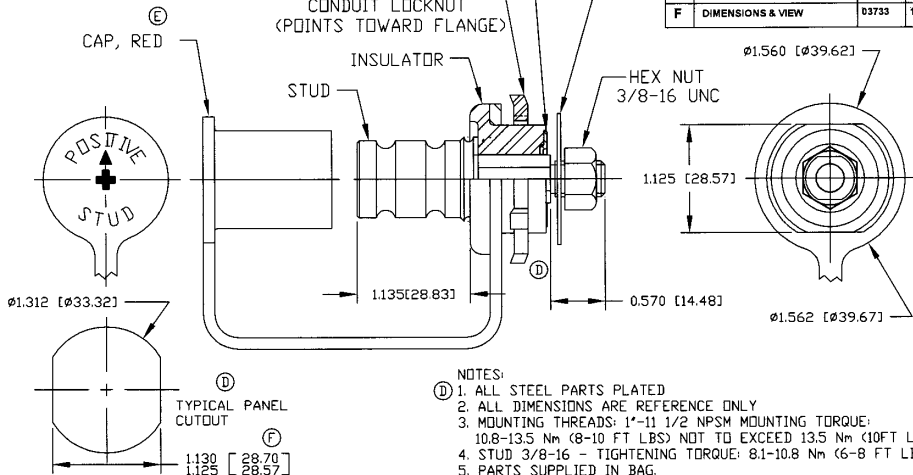

- NOTES:**
- (D) 1. ALL STEEL PARTS PLATED
  2. ALL DIMENSIONS ARE REFERENCE ONLY
  3. MOUNTING THREADS: 1"-11 1/2 NPSM MOUNTING TORQUE: 10.8-13.5 Nm (8-10 FT LBS) NOT TO EXCEED 13.5 Nm (10FT LBS)
  4. STUD 3/8-16 - TIGHTENING TORQUE: 8.1-10.8 Nm (6-8 FT LBS)
  5. PARTS SUPPLIED IN BAG.

**Tolerances.** Unless otherwise specifically noted, the following are default tolerances:

- 2-place Decimal Dimensions  $\pm .02^\circ$
- 3-place Decimal Dimensions  $\pm .005^\circ$
- Angular Dimensions  $\pm 1.0$  Deg.
- Metric: Refer to equivalent English Dimension Tolerance
- >>> NOTE: All tolerances are Non-Cumulative. <<<

**Dimensional Limits.** All dimensions are expressed in inches except those shown in brackets (xxx) are expressed in millimeters

\*RFP - or an As-Built - is Non-Toleranced Reference Dimensions, shown for identification purposes only.

**PROPRIETARY INFORMATION.** This Engineering Drawing, and the information contained herein, is proprietary to Cole Hersee Company and may not be disclosed, re-produced, or in any other way transmitted or communicated to any other party without the express written consent of an authorized representative of Cole Hersee Company.

**DESIGN CONTROL.** It is the responsibility of the individual using/ referring this drawing to assure that the noted design revision level agrees with the revision level of the Controlled Document (Master Drawing). This is a NON-CONTROLLED DOCUMENT unless otherwise specifically noted.

**DO NOT SCALE.** Dimensional variation may occur during printing/ reproduction.

**Special Characteristics...**

- Critical Characteristic, relating to Safety and/or Regulatory Compliance
- Significant Characteristic relating to Process Control (SPC)
- Key Characteristics relating to Form - Fit - Function as defined by Cole Hersee Company and/or the Customer

(Note that the identification of any Characteristics as being "Special" does not alter the requirement that ALL specified dimensions & tolerances must be met.)



**Cole Hersee Co.**

20 Old Colony Ave., South Boston, MA, 02127  
Phn 617-268-2100 Web: www.coleshersee.com

**Description:** **STUD, JUMPER, POS**

**Drawing/ Part No.:** **46210-02**

**Current Rev.:**  
**F**

Used On or Ref: **Scale: 1:1**

Drawn By: **DPS**

Date Drawn: **8/07/80**

Responsible Engineer: **SAM**

**Pg. 1 of 1**

### Revision Control Record

Rev.	Description of Change	ECN No.	Date
C	NOTES & VIEW	03189	5/29/03
D	DIMENSIONS & VIEW	3733	12/23/03

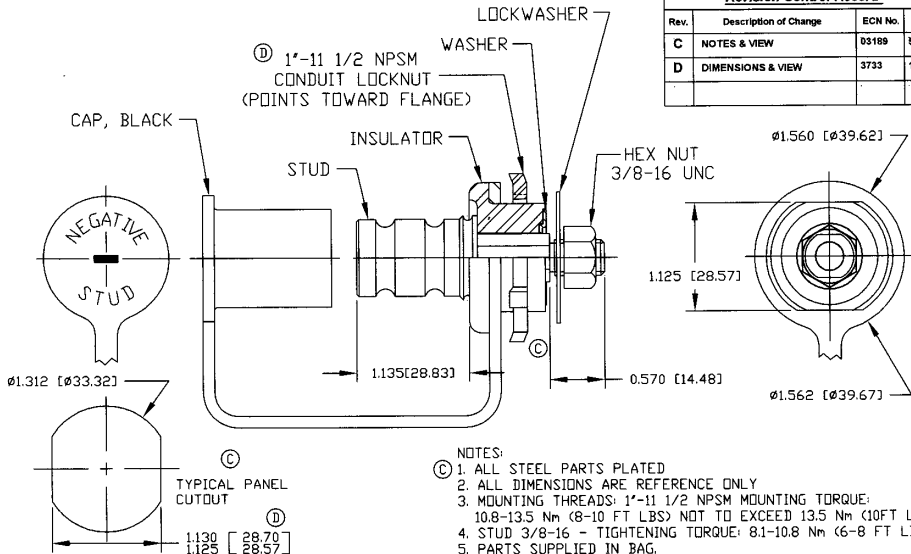

#### NOTES:

- (C) 1. ALL STEEL PARTS PLATED  
 2. ALL DIMENSIONS ARE REFERENCE ONLY  
 3. MOUNTING THREADS: 1"-11 1/2 NPSM MOUNTING TORQUE:  
 10.8-13.5 Nm (8-10 FT LBS) NOT TO EXCEED 13.5 Nm (10FT LBS)  
 4. STUD 3/8-16 - TIGHTENING TORQUE: 8.1-10.8 Nm (6-8 FT LBS)  
 5. PARTS SUPPLIED IN BAG.

**Tolerances.** Unless otherwise specifically noted, the following are default tolerances:

- \* 2-place Decimal Dimensions  $\pm .02$ "
- \* 3-place Decimal Dimensions  $\pm .005$ "
- \* Angular Dimensions  $\pm 1.0$  Deg.
- \* Metric: Refer to equivalent English Dimension Tolerance
- >>> NOTE: All tolerances are Non-Cumulative. <<<

**Dimensional Units.** All dimensions are expressed in inches except those shown in brackets (xxx) are expressed in millimeters

\*RRP\* or an Abbreviated CD = Non-Tolerance Reference Dimension, shown for identification purposes only.

**PROPRIETARY INFORMATION.** This Engineering Drawing, and the information contained herein, is proprietary to Cole Hersee Company and may not be disclosed, re-produced, or in any other way transferred or communicated to any other party without the express written consent of an authorized representative of Cole Hersee Company.

**DESIGN CONTROL.** It is the responsibility of the individual using/ referring this drawing to ensure that the noted design revision level agrees with the revision level of the Controlled Document (Master Drawing). This is a NON-CONTROLLED DOCUMENT unless otherwise specifically noted.

DO NOT SCALE - Dimensional variation may occur during printing/ reproduction.

#### Special Characteristics

- ⊠ Critical Characteristics, relating to Safety and/or Regulatory Compliance
- X Significant Characteristics relating to Process Control (SPC)
- Ⓚ Key Characteristic relating to Form - Fit - Function as defined by Cole Hersee Company and/or the Customer

(Note that the Identification of any Characteristics as being "Special" does not alter the requirement that ALL specified dimensions & tolerances must be met.)

### Cole Hersee Co.



20 Old Colony Ave., South Boston, MA, 02127  
 Phone 617-268-2100 Web: www.colehersee.com

**Description:** JUMPER STUD, NEG.

**Drawing / Part No.:** 46210-03

**Current Rev.**

D

Used On \_\_\_\_\_ Scale: 1:1

Drawn: RG

Date: 8/07/80

Responsible Engineer: SAM

Pg. 1 of 1

Revision Control Record			
Rev.	Description of Change	ECN No.	Date
H	NOTE 5	00685	9/13/00
J	NOTES & VIEW	03189	5/30/03
K	DIMENSIONS & VIEW	12/23/03	12/23/03
L	ADDED BLACK	12085	03/16/12

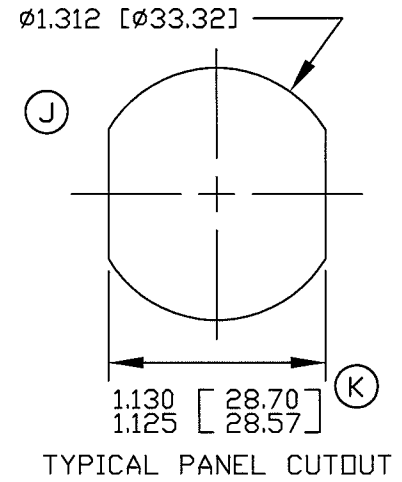
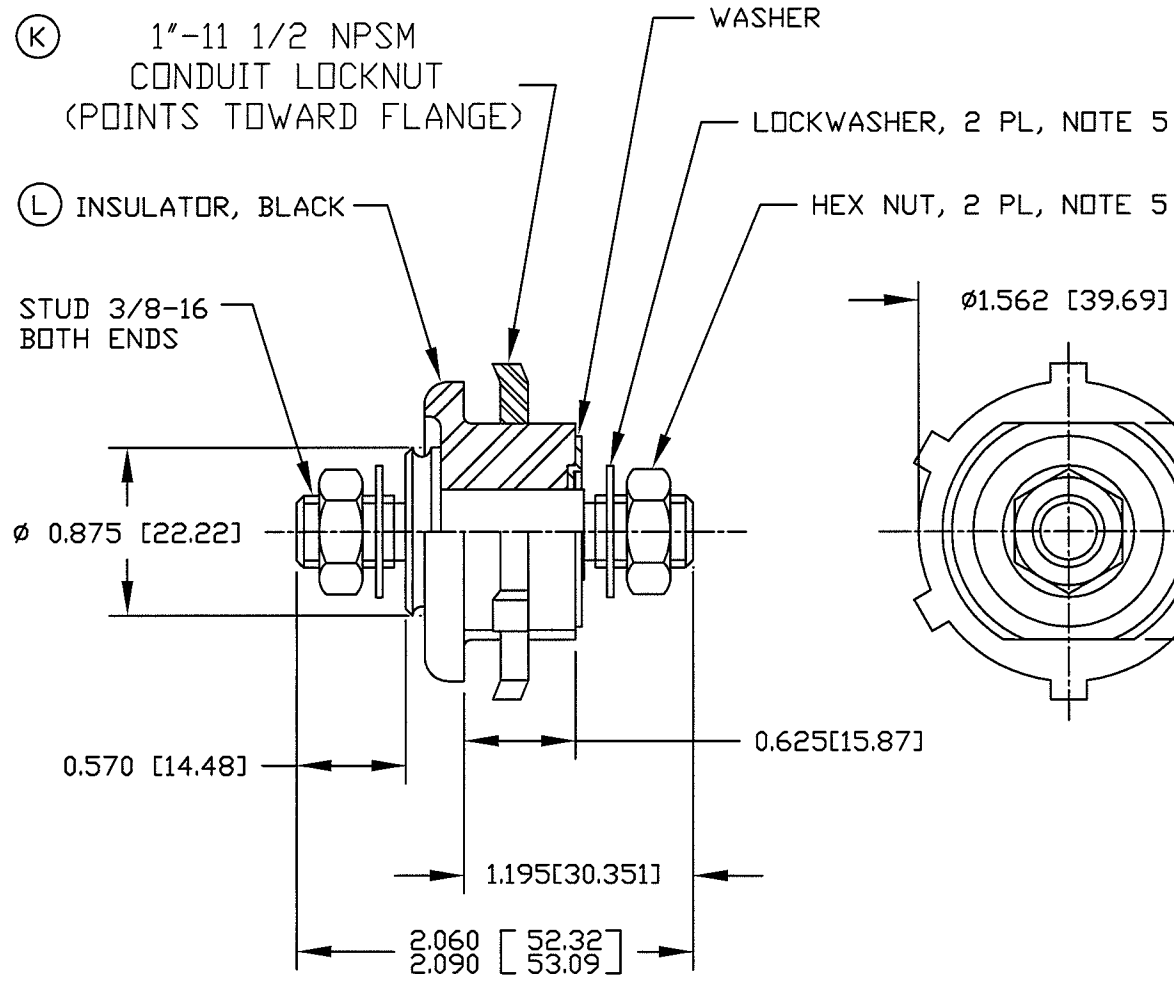

- J** NOTES:
1. ALL STEEL PARTS PLATED
  2. ALL DIMENSIONS ARE REFERENCE ONLY
  3. MOUNTING THREADS 1"-11 1/2 NPSM- MOUNTING TORQUE 10.8-13.5 Nm (8-10 FT LBS) NOT TO EXCEED 13.5 Nm (10 FT LBS)
  4. STUD 3/8-16 TIGHTENING TORQUE 8.1-10.8 Nm (6-8 FT LBS)
  5. PARTS SUPPLIED IN BAG

**Tolerances** Unless otherwise specifically noted, the following are default tolerances:  
 \* 2-place Decimal Dimensions +/- .02"  
 \* 3-place Decimal Dimensions +/- .005"  
 \* Angular Dimensions +/- 1.0 Deg.  
 \* Metric: Refer to equivalent English Dimension Tolerance  
 >>> NOTE: All tolerances are Non-Cumulative. <<<

**Dimensional Units** All dimensions are expressed in inches except those shown in brackets (xxx) are expressed in millimeters

"REF." or an Asterisk (\*) = Non-Toleranced Reference Dimension, shown for clarification purposes only.

**PROPRIETARY INFORMATION** This Engineering Drawing, and the information contained herein, is proprietary to Cole Hersee Company and may not be disclosed, re-produced, or in any other way transferred or communicated to any other party without the express written consent of an authorized representative of Cole Hersee Company.

**DESIGN CONTROL** It is the responsibility of the individual using / referencing this drawing to assure that the noted design revision level agrees with the revision level of the Controlled Document (Master Drawing). This is a NON-CONTROLLED DOCUMENT unless otherwise specifically noted.

DO NOT SCALE - Dimensional variation may occur during printing / reproduction.

**Special Characteristics:**

**CC** Critical Characteristic, relating to Safety and/or Regulatory Compliance

**X** Significant Characteristic relating to Process Control (SPC)

**KC** Key Characteristic relating to Form - Fit - Function as defined by Cole Hersee Company and/or the Customer

(Note that the identification of any Characteristics as being "Special" does not alter the requirement that ALL specified dimensions & tolerances must be met.)

**Cole Hersee Co.**  
 20 Old Colony Ave., South Boston, MA, 02127  
 Phn: 617-268-2100 Web: www.colehersee.com

**Description:** FEED THRU STUD

**Drawing / Part No.:** 46211-01

**Current Rev.:** L

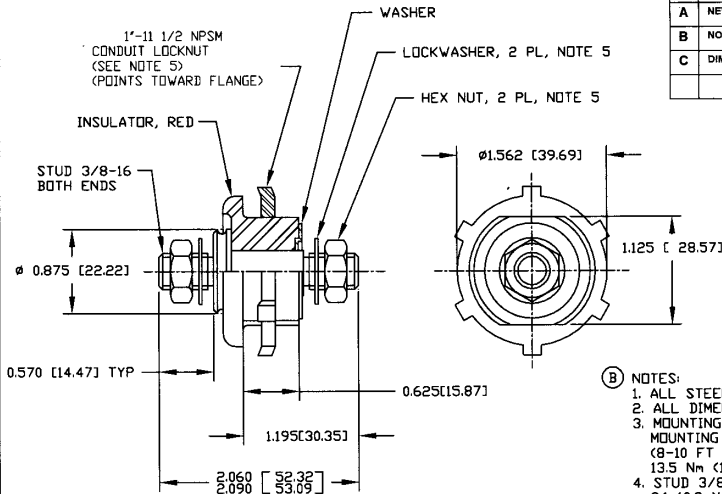

<u>Revision Control Record</u>			
Rev.	Description of Change	ECN No.	Date
A	NEW PART	02609	12/23/02
B	NOTES & VIEW	03189	5/30/03
C	DIMENSIONS & VIEW	03733	12/24/03

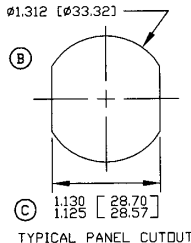

- (B) NOTES:
1. ALL STEEL PARTS PLATED
  2. ALL DIMENSIONS ARE REFERENCE ONLY
  3. MOUNTING THREADS 1'-11 1/2 NPSM-MOUNTING TORQUE 10.8-13.5 Nm (8-10 FT LBS) NOT TO EXCEED 13.5 Nm (10 FT LBS)
  4. STUD 3/8-16 TIGHTENING TORQUE 8.1-10.8 Nm (6-8 FT LBS)
  5. ALL HARDWARE SUPPLIED IN BAG

**TOLERANCES** - Unless otherwise specifically noted, the following are default tolerances:  
 \* 3-place Decimal Dimensions ±.02"  
 \* 3-place Decimal Dimensions ±.005"  
 \* Angular Dimensions ±1.0 Deg.  
 \* Metric: Refer to equivalent English Dimension Tolerance  
 \* >>> NOTE: All tolerances are Non-Cumulative. <<<

**PROPRIETARY INFORMATION** - This Engineering Drawing, and the information contained herein, is proprietary to Cole Hersee Company and may not be disclosed, re-produced, or in any other way transferred or communicated to any other party without the express written consent of an authorized representative of Cole Hersee Company.

**DESIGN CONTROL** - It is the responsibility of the individual using / referring this drawing to ensure that the noted design revision level agrees with the revision level of the Controlled Document (Drawing/Stamping). This is a NON-CONTROLLED DOCUMENT unless otherwise specifically noted.

**DO NOT SCALE** - Dimensional variation may occur during printing / reproduction.

Special Characteristics

- ⊠ Critical Characteristics, relating to Safety and/or Regulatory Compliance
- X Significant Characteristics relating to Process Control (SPC)
- (KC) Key Characteristics relating to Form - FE - Function as defined by Cole Hersee Company and/or the Customer

(Note that the identification of any Characteristics as being "Special" does not alter the requirement that ALL specified dimensions & tolerances must be met.)



**Cole Hersee Co.**

20 Old Colony Ave., South Boston, MA, 02127  
 Phone 617-268-3100 Web: www.colehersee.com

Description:

**FEED THRU STUD**

Drawing / Part No.:

**46211-R**

Current Rev.

**C**

**Revision Control Record**

Rev.	Description of Change	ECN No.	Date
E	AUTOCAD, LOGO	05424	10/26/05
F	NOTE 2 CHANGE	06300	9/07/06
G	ADDED DIM	11233	7/20/11

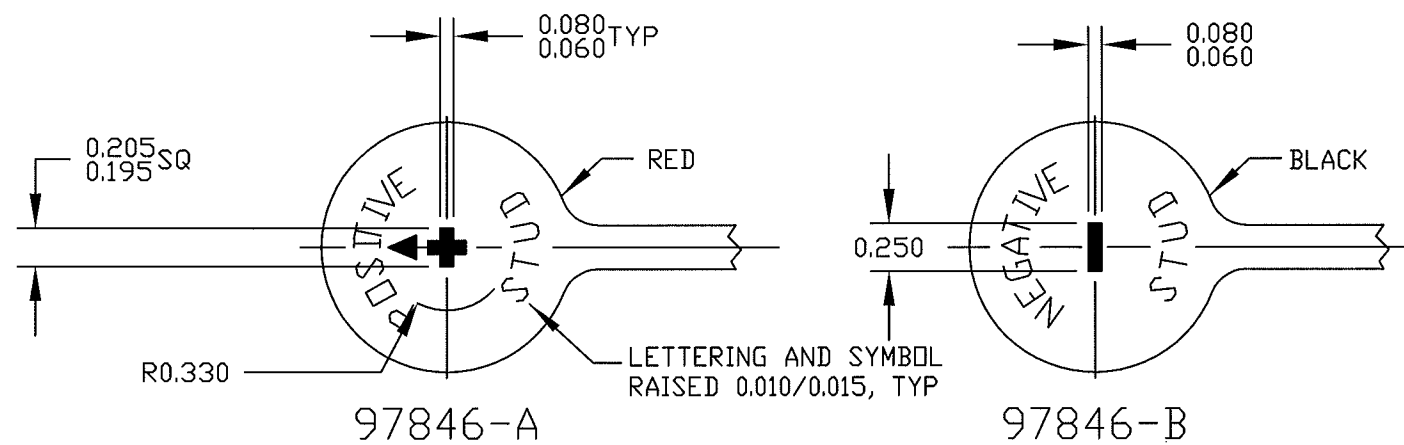
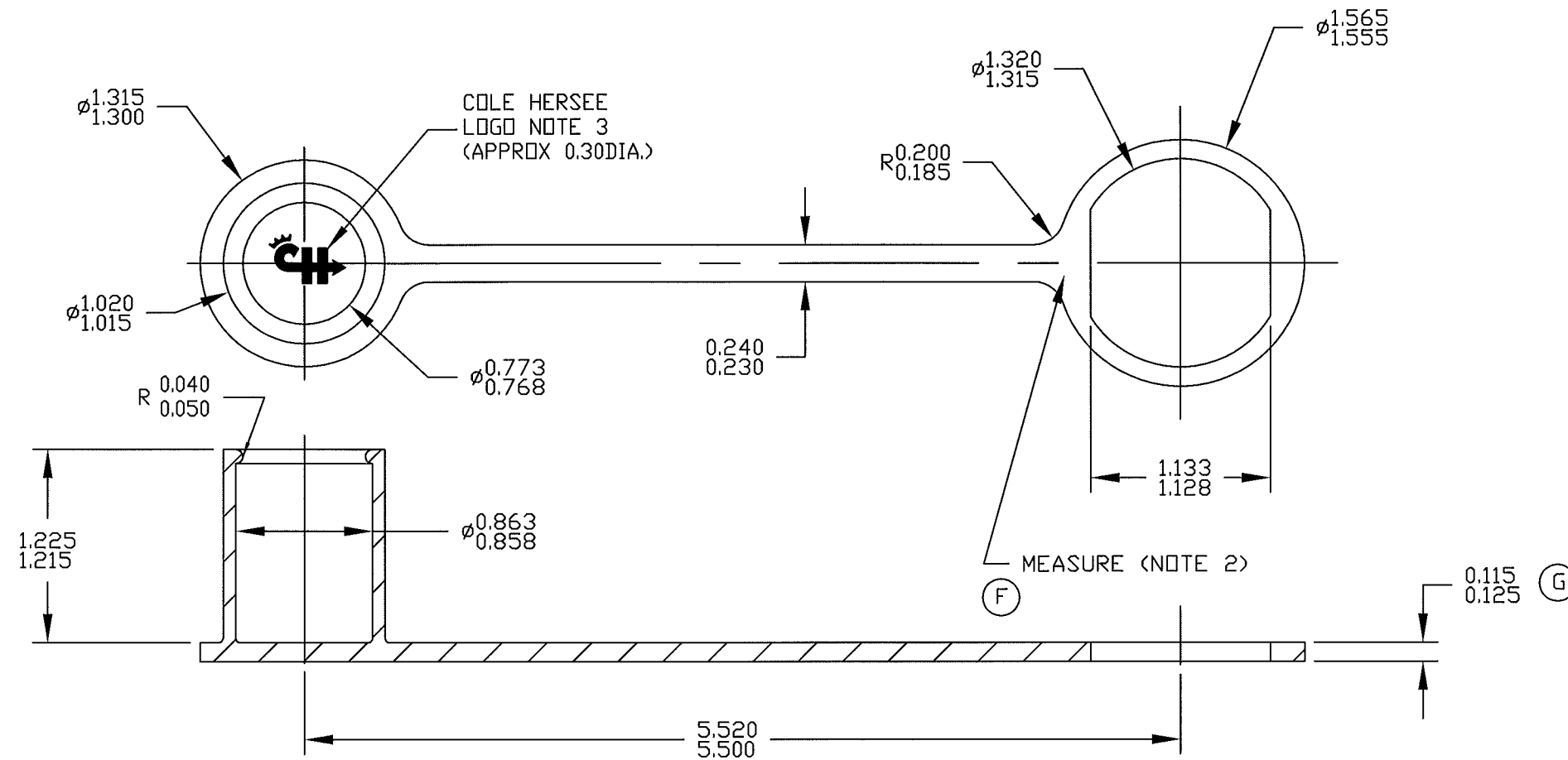

- NOTES:  
 1. MATERIAL: COASTAL DC-834, PVC  
 2. DURAMETER 60-75 SHORE A, PER ASTM SPEC. D-2287  
 3. FOR LOGO PROPORTIONS SEE COLE HERSEE DRAWING TA 139

**Tolerances** Unless otherwise specifically noted, the following are default tolerances:  
 \* 2-place Decimal Dimensions +/- .02"  
 \* 3-place Decimal Dimensions +/- .005"  
 \* Angular Dimensions +/- 1.0 Deg.  
 \* Metric: Refer to equivalent English Dimension Tolerance  
 >>> NOTE: All tolerances are Non-Cumulative. <<<

**Dimensional Units** All dimensions are expressed in inches except those shown in brackets (xxx) are expressed in millimeters

"REF." or an Asterisk (\*) = Non-Toleranced Reference Dimension, shown for clarification purposes only.

**PROPRIETARY INFORMATION** This Engineering Drawing, and the information contained herein, is proprietary to Cole Hersee Company and may not be disclosed, re-produced, or in any other way transferred or communicated to any other party without the express written consent of an authorized representative of Cole Hersee Company.

**DESIGN CONTROL** It is the responsibility of the individual using/ referencing this drawing to assure that the noted design revision level agrees with the revision level of the Controlled Document (Master Drawing). This is a NON-CONTROLLED DOCUMENT unless otherwise specifically noted.

DO NOT SCALE - Dimensional variation may occur during printing/ reproduction.

**Special Characteristics:**

- Critical Characteristic, relating to Safety and/or Regulatory Compliance
- Significant Characteristic relating to Process Control (SPC)
- Control Dimension relating to Form - Fit - Function as defined by Cole Hersee Company and/or the Customer

(Note that the identification of any Characteristics as being "Special" does not alter the requirement that ALL specified dimensions & tolerances must be met.)

**Cole Hersee Co.**  
 20 Old Colony Ave., South Boston, MA, 02127  
 Phn: 617-268-2100 Web: www.colehersee.com

**Description:**  
**CAP**

**Drawing / Part No.:** 97846-A & B

**G**

Used On or Ref.: EX18810A-10 46210-01	Scale: <b>1:1</b>	Drawn By: <b>RMT</b>	Date Drawn: <b>6/19/80</b>	Responsible Engineer: <b>SAM</b>	Pg. 1 of 1
---	-------------------	----------------------	----------------------------	----------------------------------	------------

Компания «Океан Электроники» предлагает заключение долгосрочных отношений при поставках импортных электронных компонентов на взаимовыгодных условиях!

Наши преимущества:

- Поставка оригинальных импортных электронных компонентов напрямую с производств Америки, Европы и Азии, а так же с крупнейших складов мира;
- Широкая линейка поставок активных и пассивных импортных электронных компонентов (более 30 млн. наименований);
- Поставка сложных, дефицитных, либо снятых с производства позиций;
- Оперативные сроки поставки под заказ (от 5 рабочих дней);
- Экспресс доставка в любую точку России;
- Помощь Конструкторского Отдела и консультации квалифицированных инженеров;
- Техническая поддержка проекта, помощь в подборе аналогов, поставка прототипов;
- Поставка электронных компонентов под контролем ВП;
- Система менеджмента качества сертифицирована по Международному стандарту ISO 9001;
- При необходимости вся продукция военного и аэрокосмического назначения проходит испытания и сертификацию в лаборатории (по согласованию с заказчиком);
- Поставка специализированных компонентов военного и аэрокосмического уровня качества (Xilinx, Altera, Analog Devices, Intersil, Interpoint, Microsemi, Actel, Aeroflex, Peregrine, VPT, Syfer, Eurofarad, Texas Instruments, MS Kennedy, Miteq, Cobham, E2V, MA-COM, Hittite, Mini-Circuits, General Dynamics и др.);

Компания «Океан Электроники» является официальным дистрибьютором и эксклюзивным представителем в России одного из крупнейших производителей разъемов военного и аэрокосмического назначения «JONHON», а так же официальным дистрибьютором и эксклюзивным представителем в России производителя высокотехнологичных и надежных решений для передачи СВЧ сигналов «FORSTAR».



## JONHON

«JONHON» (основан в 1970 г.)

Разъемы специального, военного и аэрокосмического назначения:

(Применяются в военной, авиационной, аэрокосмической, морской, железнодорожной, горно- и нефтедобывающей отраслях промышленности)

«FORSTAR» (основан в 1998 г.)

ВЧ соединители, коаксиальные кабели,  
кабельные сборки и микроволновые компоненты:

(Применяются в телекоммуникациях гражданского и специального назначения, в средствах связи, РЛС, а так же военной, авиационной и аэрокосмической отраслях промышленности).



Телефон: 8 (812) 309-75-97 (многоканальный)

Факс: 8 (812) 320-03-32

Электронная почта: [ocean@oceanchips.ru](mailto:ocean@oceanchips.ru)

Web: <http://oceanchips.ru/>

Адрес: 198099, г. Санкт-Петербург, ул. Калинина, д. 2, корп. 4, лит. А