

MICRO SWITCH™ Miniature Safety Switches

924CE Series

004786

Issue 1

Datasheet



DESCRIPTION

Honeywell's 924CE Series of miniature electromechanical safety switches are designed with a rugged metal housing. This Series features positive opening normally closed contacts \rightarrow to EN/IEC 60947-5-1-3 specifications. Due to their small size and positive opening normally closed contact; the 924CE Series provides a safety solution for applications where the size of other products could be prohibitive on the machinery. The 924CE Series offers a variety of configurations which include a wide range of actuators, circuits, and electrical terminations to solve many application issues. These miniature switches are environmentally sealed to IP66 for demanding environments on indoor or outdoor machinery. In addition, the 924CE Series has been evaluated for safety functions up to a safety integrity level (SIL) of SIL3 when evaluated to the requirements of IEC 61508-2:2010.

VALUE TO CUSTOMERS

- Miniature rugged 924CE switches with common 25,4 mm [1.0 in] mounting footprint
- Switches easily gang mounted for multi-pole capability
- Low temperature option of -40 °C [-40 °F]
- Long life of up to 10 million mechanical operations
- Several electrical connection options: pre-cabled with different lengths; ac or dc Micro connectors with 4-pin or 5-pin options

DIFFERENTIATION

- Miniature metal body size of 40 mm L x 16 mm W x 49 mm H requires less space on machinery
- Positive opening normally closed contacts \rightarrow with an optional normally open contact
- Designed and evaluated for safety functions up to a SIL3 level

FEATURES

- Compact metal housing epoxy encapsulated with the common 25,4 mm [1.0 in] center-to-center mounting
- Positive opening operation of normally closed contacts \rightarrow to EN/IEC 60947-5-1-3 specification
- Designed and agency evaluated for safety functions up to a SIL3 level
- Three different slow-action circuit options: 1NC/1NO BBM (break-before-make), 1NC/1NO MBB (make-before-break), and 1NC
- Wide range of actuator heads and levers
- Can be gang mounted for multiple-pole capability
- Certified for global applications; cULus and CE
- Environmentally sealed to IP66
- Standard temperature operating range of 0 °C to 70 °C [32 °F to 158 °F]
- Optional low temperature operating range of -40 °C to 70 °C [-40 °F to 158 °F]

POTENTIAL APPLICATIONS

- Industrial
 - Machine tools (small doors and apertures)
 - Material handling
 - Packaging machinery
 - Trailer/truck restraint systems (dok-loks)
- Transportation
 - Small construction machinery

PORTFOLIO

MICRO SWITCH™ 924CE Series miniature safety switches complement the [24CE Series](#) of miniature safety limit switches. These Series of switches are a small segment of the total family of Honeywell's MICRO SWITCH™ electromechanical safety switches.

MICRO SWITCH™ Miniature Safety Switches, 924CE Series

Table 1. Specifications

Characteristic	Parameter
Description	Miniature safety electromechanical switch
Certifications	CE, cULus, SIRA, IEC/EN60947-5-1
Housing material	Epoxy coated die-cast zinc
Actuators	Pin plunger (924CE1-) Roller plunger parallel (924CE2-) Roller plunger perpendicular (924CE3-) Rotary (924CE16-) Pin plunger with boot seal (924CE18-) Adjustable plunger (924CE19-) Roller plunger parallel, panel mount (924CE28-) Roller plunger perpendicular, panel mount (924CE29-) Roller plunger parallel with boot seal (924CE31-) Roller plunger perpendicular with boot seal (924CE55-)
Termination (electrical connection)	3 core or 5 core SJTO cable, Integral dc Micro connector (4-pin or 5-pin), Integral ac Micro connector (5-pin)
Contact options	1NC/1NO BBM (break-before-make), 1NC/1NO MBB (make-before-break), 1NC (all normally closed contacts are positive opening) →
Contact type	Slow action
Contact material	Silver alloy
Utilization category	AC15, B300; DC13, R300
Rated operational voltage (Ue)	240 V ac or dc
Rated operational current	1.5 A, 0.1 A
Rated thermal current (Ith)	10 A
Rated impulse withstand (Uimp)	2500 V
Maximum fuse rating	10 A
Environmental sealing	IP66
Operating temperature	Standard: 0 °C to 70 °C [32 °F to 158 °F] Optional: -40 °C to 70 °C [-40 °F to 158 °F]
MCTF (Mechanical life)	>1,000,000 cycles
MCTF (Electrical life)	>25,000 cycles
SIL Capability	Up to SIL3 (HFT1), IEC61508-2:2010
Proof test interval	1 year

Table 2. Electrical Ratings EN/IEC 60947-5-1

ac				dc			
B300	AC15	VA Rating		R300	DC13	VA Rating	
UE	IE	Make	Break	UE	IE	Make	Break
(Volts)	(Amps)			(Volts)	(Amps)		
120	3	3600	360	125	0.22	28	28
240	1.5	3600	360	250	0.1	28	28

cULus (E41859), CE

Cable: 10 A, 250 Vac; 1/3 hp, 125/250 Vac

Connector: 4 A, 250 Vac

MICRO SWITCH™ Miniature Safety Switches, 924CE Series

Figure 1. Product Nomenclature

924CE Switch Type	1 Head Type	S Contact Arrangement and Type	3 Cable Length*	1 Options**
924CE Miniature Safety Switch	1 Top pin plunger Ø 10 mm (sst)	S 1NC/1NO SPDT BBM slow action	3 3 feet of cable	A Side exit cable or connector
	2 Top roller plunger parallel, Ø12,7 x 4,7 wide (steel)	T 1NC/1NO SPDT MBB slow action	6 6 feet of cable	L Low temperature design, cable and switch
	3 Top roller plunger perpend., Ø12,7 x 4,7 wide (steel)	Y 1NC SPST slow action	9 9 feet of cable	L1 Low temperature design, switch only, cable not flexing
	16 Front rotary (less lever)		15 15 feet of cable	P Top mounting holes (2) with 8-32 thread
	18 Top pin plunger 10 mm (sst) with boot seal			Q 5-pin dc type single keyway
	19 Top adj. plunger 4 mm hex screw (sst)			Q1 5-pin ac type two keyways
	28 Top roller plunger parallel, Ø12,7 x 4,7 wide (steel), panel mount			YQ 4-pin dc type single keyway for contact option Y
	29 Top roller plunger perpend., Ø12,7 x 4,7 wide (steel), panel mount			
	31 Top roller plunger parallel, Ø12,7 x 4,7 wide (steel), boot seal			
	55 Top roller plunger perpend., Ø12,7 x 4,7 wide (steel), boot seal			

* For other cable lengths available, contact your Honeywell provider.

** More than one option may be permissible.

MICRO SWITCH™ Miniature Safety Switches, 924CE Series

GANG-MOUNT CAPABILITY

The 924CE Series housing has been designed to enable the user to build their own multiple plunger switch by gang mounting several switches. All pin plunger and roller plunger types are suitable for gang mounting. There is a 16 mm distance between the plungers. The Series is very versatile such that even a lever-type version could be added at the end of the row.

BOTTOM-EXIT OR SIDE-EXIT ORIENTATION

The 924CE Series has been designed with a pre-wired cable fitted in the bottom of the switch housing. Other variations are available with a side-exit cable.

CONNECTOR VERSIONS

The 924CE Series is available with a Micro connector in a bottom-exit or side-exit version.

MOUNTING

MICRO SWITCH™ 924CE Series safety switches are mounted by using two M5 or #10 screws. The mounting holes are counter bored to keep the screw heads within the overall switch housing dimensions.

APPLICATION ILLUSTRATION

Two 924CE roller plunger switches to monitor gate position, closed or open.

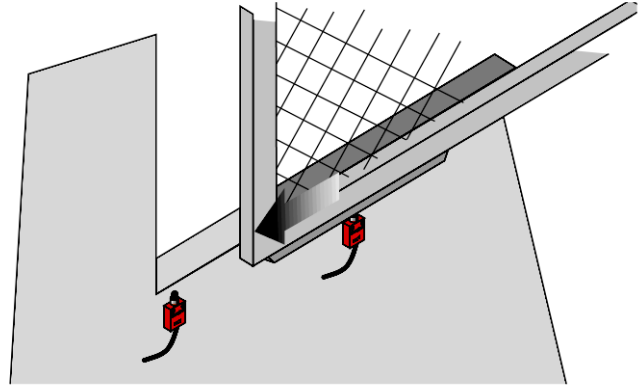





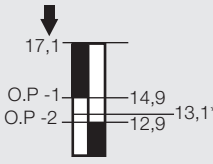

CONTACT ARRANGEMENT AND DESCRIPTION

Circuit Type		Circuit Diagram	Cable/Connector
S	BBM		5 x 18 AWG SJTO (UL approved)
T	MBB		5 x 18 AWG SJTO (UL approved)
Y	SPNC		3 x 18 AWG SJTO (UL/CSA approved)
dc connector, 4-pin, M12 thread (Option -YQ)			
ac connector, 5-pin, 0.5 in x 20 UNF thread (Option -Q1)			
dc connector, 5-pin, M12 thread (Option -Q)			

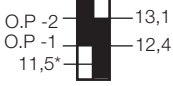
MICRO SWITCH™ Miniature Safety Switches, 924CE Series

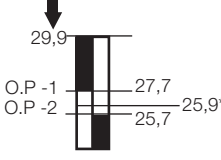
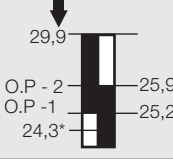
Table 3. 924CE Order Guide

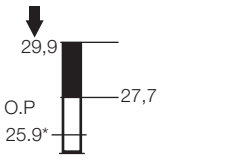



	Head Type	Catalog Listing**	Contact Arrangement [slow action]	Operating Force or Torque (max.)	Bar Chart ■ Contact Closed □ Contact Open mm or °	Options	Termination/Connection
	Top pin plunger, Ø 10 mm [sst]	924CE1-S3	1NC/1NO BBM	22,5 N [5.06 lb]		-	3 ft cable
		924CE1-S6				-	6 ft cable
		924CE1-S9				-	9 ft cable
		924CE1-T3	1NC/1NO MBB	22,5 N [5.06 lb]		-	3 ft cable
		924CE1-T9				-	9 ft cable
		924CE1-T3A	1NC/1NO MBB	22,5 N [5.06 lb]		Side exit cable	3 ft cable
		924CE1-T6A				-	6 ft cable
		924CE1-Y3	1NC	22,5 N [5.06 lb]		-	3 ft cable
924CE1-Y9	-	9 ft cable					
	Top roller plunger, parallel Ø12,7 x 4,7 mm wide [steel]	924CE2-S3	1NC/1NO BBM	22,5 N [5.06 lb]		-	3 ft cable
		924CE2-S6				-	6 ft cable
		924CE2-S9				-	9 ft cable
		924CE2-S9A	1NC/1NO BBM	22,5 N [5.06 lb]		Side exit cable	9 ft cable
		924CE2-T3	1NC/1NO MBB	22,5 N [5.06 lb]		-	3 ft cable
		924CE2-T6				-	6 ft cable
		924CE2-T9	1NC	22,5 N [5.06 lb]		-	9 ft cable
		924CE2-Y3	1NC	22,5 N [5.06 lb]		-	3 ft cable
924CE2-Y9	-	9 ft cable					

* Positive opening to IEC/EN 60947-5-1-3

**Catalog listings are with 3 feet, 6 feet, 9 feet of cable or integral connector. For other cable lengths or connectors contact your Honeywell provider

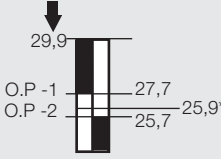
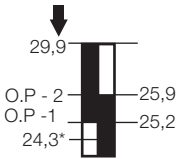
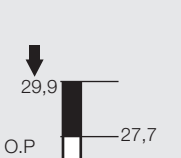
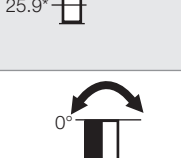
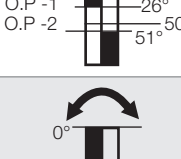
MICRO SWITCH™ Miniature Safety Switches, 924CE Series

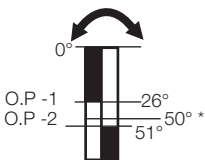
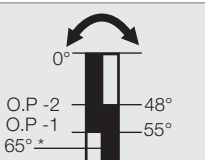
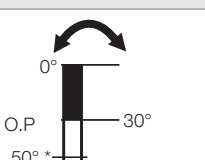
Table 3. 924CE Order Guide, continued

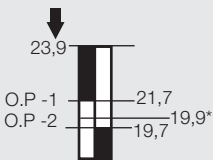
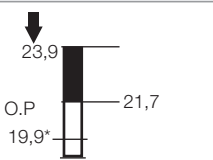



	Head Type	Catalog Listing**	Contact Arrangement [slow action]	Operating Force or Torque (max.)	Bar Chart ■ Contact Closed □ Contact Open mm or °	Options	Termination/ Connection
	Top roller plunger, perpendicular Ø12,7 x 4,7 mm wide [steel]	924CE3-S3	1NC/1NO BBM	22,5 N [5.06 lb]		-	3 ft cable
		924CE3-S6				-	6 ft cable
		924CE3-S9				-	9 ft cable
		924CE3-T9	1NC/1NO MBB	22,5 N [5.06 lb]		-	9 ft cable
		924CE3-Y3	1NC	22,5 N [5.06 lb]		-	3 ft cable
		924CE3-Y6		22,5 N [5.06 lb]		-	6 ft cable
		924CE3-Y9A	1NC	22,5 N [5.06 lb]		-	Side exit cable 9 ft cable
924CE3-Y9P	1NC	22,5 N [5.06 lb]		-	Top mounting holes (2) 8-32 thread 9 ft cable		
	Front rotary [less lever] (see page 10 for lever selection)	924CE16-S3	1NC/1NO BBM	0,30 Nm [2.66 inlb]		-	3 ft cable
		924CE16-S9				-	9 ft cable
		924CE16-T3	1NC/1NO MBB	0,30 Nm [2.66 inlb]		-	3 ft cable
		924CE16-Y3	1NC	0,30 Nm [2.66 inlb]		-	3 ft cable
		924CE16-Y9				-	9 ft cable
	Top pin plunger, Ø 7,1 mm [sst] with boot seal	924CE18-S6	1NC/1NO BBM	22,5 N [5.06 lb]		-	6 ft cable
		924CE18-Y3AL	1NC	22,5 N [5.06 lb]		-	Side exit cable, low temp. switch & cable construction 3 ft cable

* Positive opening to IEC/EN 60947-5-1-3

**Catalog listings are with 3 feet, 6 feet, 9 feet of cable or integral connector. For other cable lengths or connectors contact your Honeywell provider

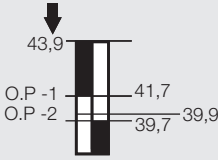
MICRO SWITCH™ Miniature Safety Switches, 924CE Series

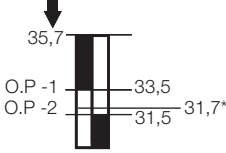
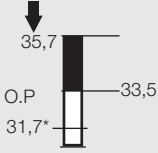
Table 3. 924CE Order Guide, continued

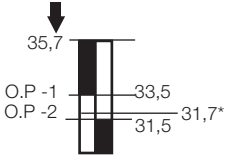
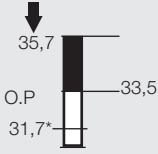
	Head Type	Catalog Listing**	Contact Arrangement [slow action]	Operating Force or Torque (max.)	Bar Chart ■ Contact Closed □ Contact Open mm or °	Options	Termination/ Connection
	Top roller plunger, parallel Ø12,7 x 4,7 mm wide [steel], panel mount	924CE28-S3	1NC/1NO BBM	22,5 N [5.06 lb]		–	3 ft cable
	Top roller plunger, parallel Ø12,7 x 4,7 mm wide [steel], with boot seal	924CE31-S6	1NC/1NO BBM	25,5 N [5.73 lb]		–	6 ft cable
		924CE31-Y3L1	1NC	25,5 N [5.73 lb]		Low temp. switch construction	3 ft cable
	Top roller plunger, perpendicular Ø12,7 x 4,7 mm wide [steel], with boot seal	924CE55-SQ1	1NC/1NO BBM	25,5 N [5.73 lb]		Two keyways [5 pin]	Micro connector, ac type
		924CE55-SAQ1	1NC/1NO BBM	25,5 N [5.73 lb]		Side exit, two keyways [5 pin]	Micro connector, ac type
		924CE55-Y3A	1NC	25,5 N [5.73 lb]		Side exit cable	3 ft cable

* Positive opening to IEC/EN 60947-5-1-3

**Catalog listings are with 3 feet, 6 feet, 9 feet of cable or integral connector.

For other cable lengths or connectors contact your Honeywell provider

MICRO SWITCH™ Miniature Safety Switches, 924CE Series

DIMENSIONAL DRAWINGS

Figure 2. 924CE General Dimensions

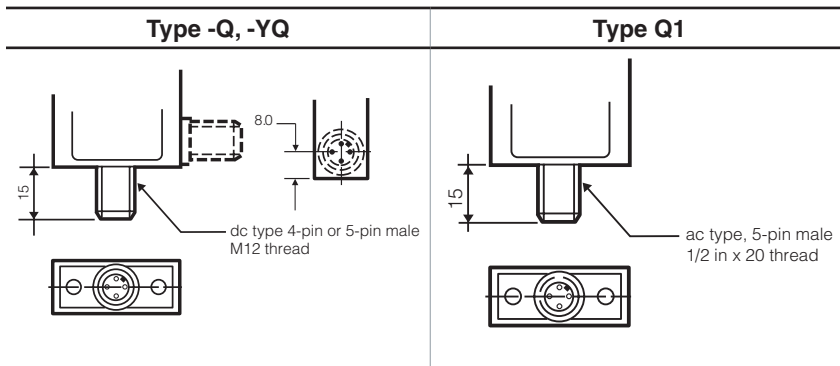
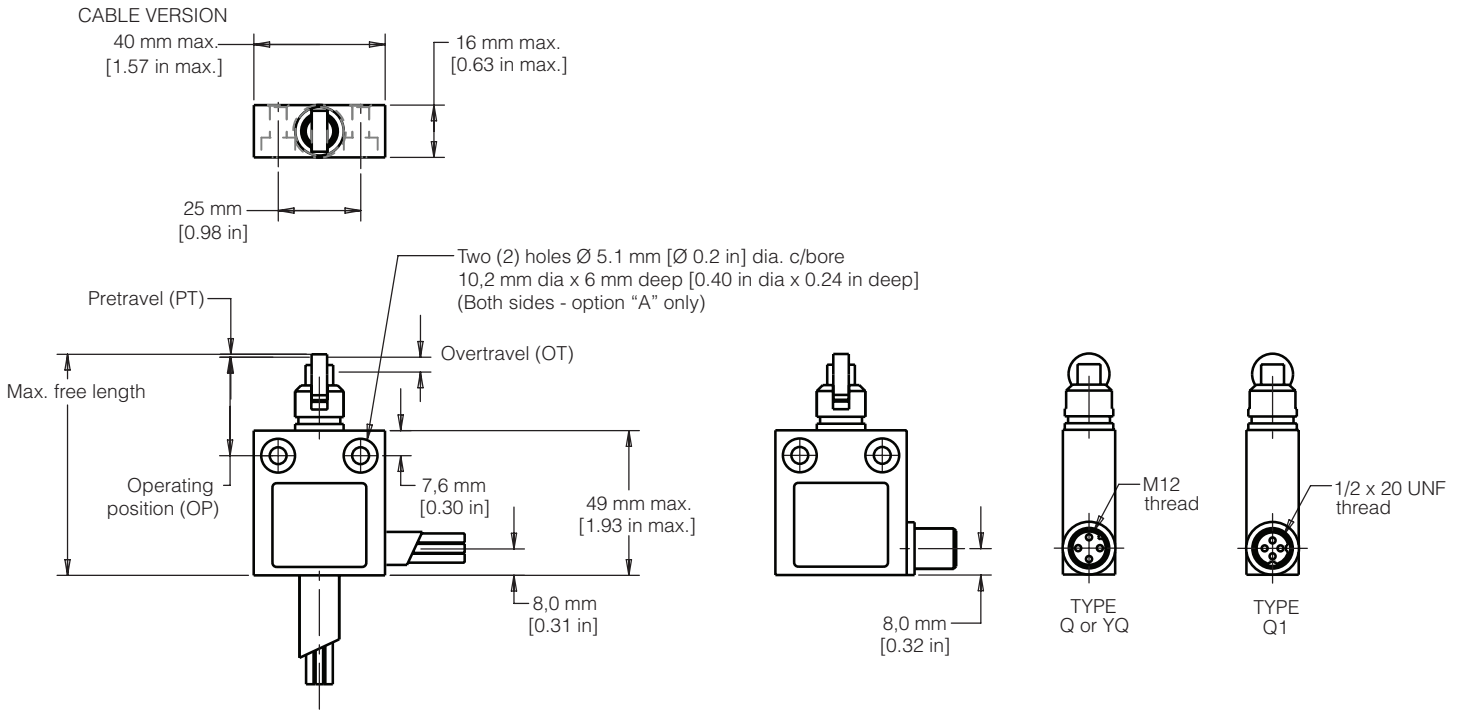

MICRO SWITCH™ Miniature Safety Switches, 924CE Series

mm [in]

Figure 3. 924CE1 Dimensions

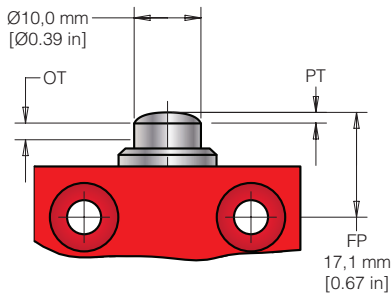

Pin Plunger Operating Characteristics	S 1NC/1NO (BBM)	T 1NC/1NO (MBB)	Y 1NC
Free position (±0,4 [0.02])	17,1 [0.67]	17,1 [0.67]	17,1 [0.67]
Pretravel (max.)	2,2 [0.09]	4,0 [0.16]	2,2 [0.09]
Overtravel (min.)	1,0 [0.04]	0,5 [0.02]	-

Figure 4. 924CE2 Dimensions

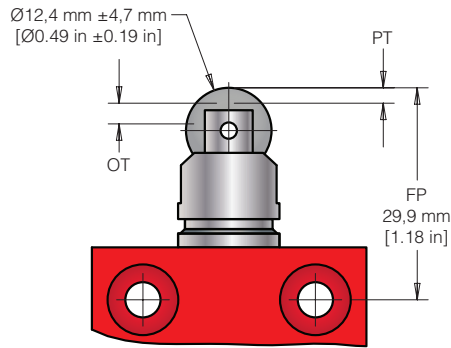

Roller Plunger Operating Characteristics	S 1NC/1NO (BBM)	T 1NC/1NO (MBB)	Y 1NC
Free position (±0,4 [0.02])	29,9 [1.18]	29,9 [1.18]	29,9 [1.18]
Pretravel (max.)	2,2 [0.09]	4,0 [0.16]	2,2 [0.09]
Overtravel (min.)	1,0 [0.04]	0,5 [0.02]	-

Figure 5. 924CE3 Dimensions

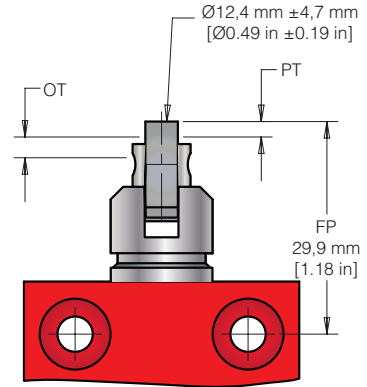

Roller Plunger Operating Characteristics	S 1NC/1NO (BBM)	T 1NC/1NO (MBB)	Y 1NC
Free position (±0,4 [0.02])	29,9 [1.18]	29,9 [1.18]	29,9 [1.18]
Pretravel (max.)	2,2 [0.09]	4,0 [0.16]	2,2 [0.09]
Overtravel (min.)	1,0 [0.04]	0,5 [0.02]	-

Figure 6. 924CE16 Dimensions

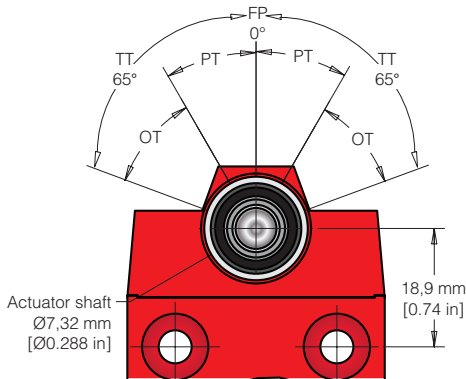

Side Rotary Operating Characteristics	S 1NC/1NO (BBM)	T 1NC/1NO (MBB)	Y 1NC
Free position (degrees)	0	0	0
Pretravel (max. degrees)	26	48	26
Total travel (min. degrees)	65	65	65

Figure 7. 924CE18 Dimensions

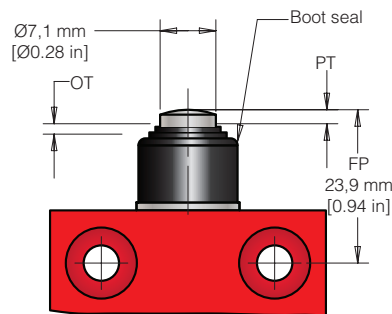

Pin Plunger with Boot Seal Operating Characteristics	S 1NC/1NO (BBM)	T 1NC/1NO (MBB)	Y 1NC
Free position (±0,4 [0.02])	23,9 [0.94]	23,9 [0.94]	23,9 [0.94]
Pretravel (max.)	2,2 [0.09]	4,0 [0.16]	2,2 [0.09]
Overtravel (min.)	1,0 [0.04]	0,5 [0.02]	-

Figure 8. 924CE19 Dimensions

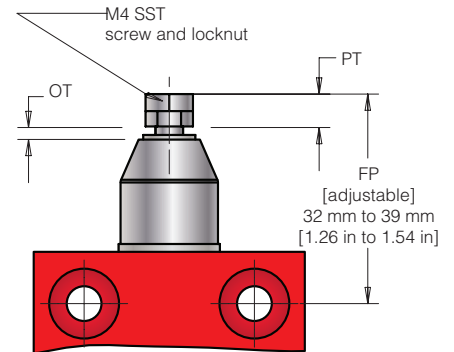

Top Adjustable Plunger Operating Characteristics	S 1NC/1NO (BBM)	T 1NC/1NO (MBB)	Y 1NC
Free position (adjustable)	32 to 39 [1.26 to 1.54]	32 to 39 [1.26 to 1.54]	32 to 39 [1.26 to 1.54]
Pretravel (max.)	2,2 [0.09]	4,0 [0.16]	2,2 [0.09]
Overtravel (min.)	1,0 [0.04]	0,5 [0.02]	-

MICRO SWITCH™ Miniature Safety Switches, 924CE Series

Figure 9. 924CE28 Dimensions

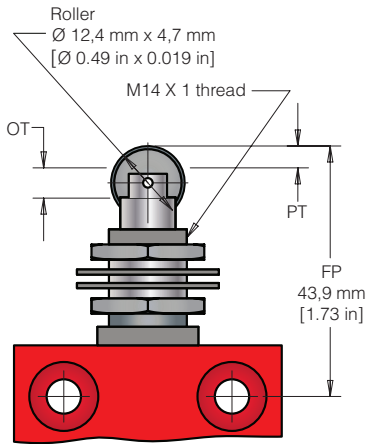

Top Roller Plunger with Panel Mount Operating Characteristics	S 1NC/1NO (BBM)	T 1NC/1NO (MBB)	Y 1NC
Free position (±0,4 [0.02])	43,9 [1.73]	43,9 [1.73]	43,9 [1.73]
Pretravel (max.)	2,2 [0.09]	4,0 [0.16]	2,2 [0.09]
Overtravel (min.)	1,0 [0.04]	0,5 [0.02]	-

Figure 10. 924CE29 Dimensions

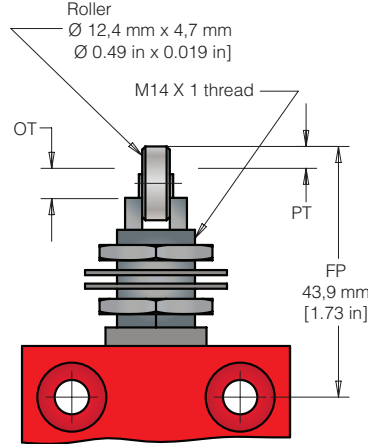

Top Roller Plunger with Panel Mount Operating Characteristics	S 1NC/1NO (BBM)	T 1NC/1NO (MBB)	Y 1NC
Free position (±0,4 [0.02])	43,9 [1.73]	43,9 [1.73]	43,9 [1.73]
Pretravel (max.)	2,2 [0.09]	4,0 [0.16]	2,2 [0.09]
Overtravel (min.)	1,0 [0.04]	0,5 [0.02]	-

Figure 11. 924CE31 Dimensions

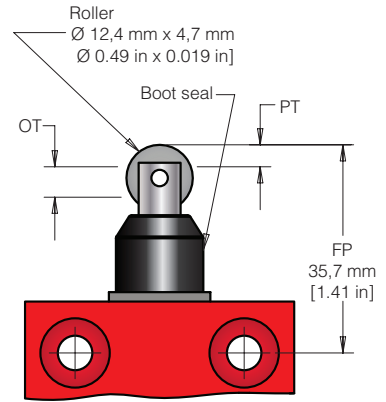

Roller Plunger with Boot Seal Operating Characteristics	S 1NC/1NO (BBM)	T 1NC/1NO (MBB)	Y 1NC
Free position (±0,4 [0.02])	35,7 [1.41]	35,7 [1.41]	35,7 [1.41]
Pretravel (max.)	2,2 [0.09]	4,0 [0.16]	2,2 [0.09]
Overtravel (min.)	1,0 [0.04]	0,5 [0.02]	-

Figure 12. 924CE55 Dimensions

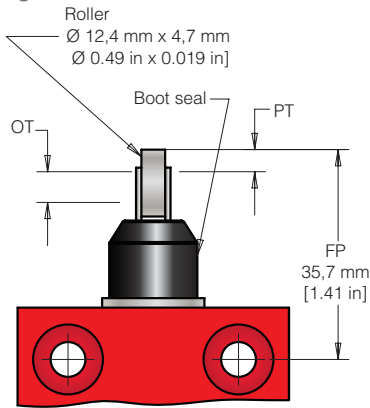

Roller Plunger with Boot Seal Operating Characteristics	S 1NC/1NO (BBM)	T 1NC/1NO (MBB)	Y 1NC
Free position (±0,4 [0.02])	35,7 [1.41]	35,7 [1.41]	35,7 [1.41]
Pretravel (max.)	2,2 [0.09]	4,0 [0.16]	2,2 [0.09]
Overtravel (min.)	1,0 [0.04]	0,5 [0.02]	-

Table 4. Levers for Use With 924CE Front Rotary Switches

	Catalog Listing	Rod/Roller Material	Rod/Roller Dia. mm [in]	Roller Width mm [in]
Fixed length lever; 38,1 mm [1.5 in] radius				
	GLZ51A	Nylon	19,0 [0.75]	6,35 [0.25]
	GLZ51B	Steel	19,0 [0.75]	6,35 [0.25]
	GLZ51C	Nylon	25,4 [1.00]	12,7 [0.50]
	GLZ51E	Bronze	19,0 [0.75]	6,35 [0.25]
	GLZ51T	SST	19,0 [0.75]	9,5 [0.38]
Fixed length offset lever; 38,1 mm [1.5 in] radius				
	GLZ55A	Nylon	19,0 [0.75]	6,35 [0.25]
	GLZ55B	Steel	19,0 [0.75]	6,35 [0.25]
	GLZ55E	Bronze	19,0 [0.75]	6,35 [0.25]

ADDITIONAL MATERIALS

The following associated literature is available on the Honeywell web site at sensing.honeywell.com:

- Product line guide
- Product range guide
- Installation instructions
- Certificates: SIL
- Certificates: Electrical endurance
- Certificates: Mechanical endurance
- Safety switch quick reference guide

Find out more

Honeywell serves its customers through a worldwide network of sales offices, representatives and distributors. For application assistance, current specifications, pricing or name of the nearest Authorized Distributor, contact your local sales office. To learn more about Honeywell's sensing and control products, call **+1-815-235-6847** or **1-800-537-6945**, visit **sensing.honeywell.com**, or e-mail inquiries to **info.sc@honeywell.com**

Sensing and Productivity Solutions
Honeywell
1985 Douglas Drive North
Golden Valley, MN 55422
honeywell.com

WARNING **RISK TO LIFE OR PROPERTY**

Never use this product for an application involving serious risk to life or property without ensuring that the system as a whole has been designed to address the risks, and that this product is properly rated and installed for the intended use within the overall system.

Failure to comply with these instructions could result in death or serious injury.

WARNING **MISUSE OF DOCUMENTATION**

- The information presented in this product sheet is for reference only. Do not use this document as a product installation guide.
- Complete installation, operation, and maintenance information is provided in the instructions supplied with each product.

Failure to comply with these instructions could result in death or serious injury.

Warranty/Remedy

Honeywell warrants goods of its manufacture as being free of defective materials and faulty workmanship. Honeywell's standard product warranty applies unless agreed to otherwise by Honeywell in writing; please refer to your order acknowledgement or consult your local sales office for specific warranty details. If warranted goods are returned to Honeywell during the period of coverage, Honeywell will repair or replace, at its option, without charge those items it finds defective. **The foregoing is buyer's sole remedy and is in lieu of all other warranties, expressed or implied, including those of merchantability and fitness for a particular purpose. In no event shall Honeywell be liable for consequential, special, or indirect damages.**

While we provide application assistance personally, through our literature and the Honeywell web site, it is up to the customer to determine the suitability of the product in the application.

Specifications may change without notice. The information we supply is believed to be accurate and reliable as of this printing. However, we assume no responsibility for its use.

Honeywell

Компания «Океан Электроники» предлагает заключение долгосрочных отношений при поставках импортных электронных компонентов на взаимовыгодных условиях!

Наши преимущества:

- Поставка оригинальных импортных электронных компонентов напрямую с производств Америки, Европы и Азии, а так же с крупнейших складов мира;
- Широкая линейка поставок активных и пассивных импортных электронных компонентов (более 30 млн. наименований);
- Поставка сложных, дефицитных, либо снятых с производства позиций;
- Оперативные сроки поставки под заказ (от 5 рабочих дней);
- Экспресс доставка в любую точку России;
- Помощь Конструкторского Отдела и консультации квалифицированных инженеров;
- Техническая поддержка проекта, помощь в подборе аналогов, поставка прототипов;
- Поставка электронных компонентов под контролем ВП;
- Система менеджмента качества сертифицирована по Международному стандарту ISO 9001;
- При необходимости вся продукция военного и аэрокосмического назначения проходит испытания и сертификацию в лаборатории (по согласованию с заказчиком);
- Поставка специализированных компонентов военного и аэрокосмического уровня качества (Xilinx, Altera, Analog Devices, Intersil, Interpoint, Microsemi, Actel, Aeroflex, Peregrine, VPT, Syfer, Eurofarad, Texas Instruments, MS Kennedy, Miteq, Cobham, E2V, MA-COM, Hittite, Mini-Circuits, General Dynamics и др.);

Компания «Океан Электроники» является официальным дистрибьютором и эксклюзивным представителем в России одного из крупнейших производителей разъемов военного и аэрокосмического назначения «JONHON», а так же официальным дистрибьютором и эксклюзивным представителем в России производителя высокотехнологичных и надежных решений для передачи СВЧ сигналов «FORSTAR».



JONHON

«JONHON» (основан в 1970 г.)

Разъемы специального, военного и аэрокосмического назначения:

(Применяются в военной, авиационной, аэрокосмической, морской, железнодорожной, горно- и нефтедобывающей отраслях промышленности)

«FORSTAR» (основан в 1998 г.)

ВЧ соединители, коаксиальные кабели, кабельные сборки и микроволновые компоненты:

(Применяются в телекоммуникациях гражданского и специального назначения, в средствах связи, РЛС, а так же военной, авиационной и аэрокосмической отраслях промышленности).



Телефон: 8 (812) 309-75-97 (многоканальный)

Факс: 8 (812) 320-03-32

Электронная почта: ocean@oceanchips.ru

Web: <http://oceanchips.ru/>

Адрес: 198099, г. Санкт-Петербург, ул. Калинина, д. 2, корп. 4, лит. А