

**MAXIM**

## 2 or 3-Cell, Step-Up/Down, Two-Way Pager System IC

MAX769

### General Description

The MAX769 is a complete buck/boost power supply and monitoring system for two-way pagers or other low-power digital communications devices. Few external components are required. Included on-chip are:

- An 80mA output, synchronous-rectified, buck/boost DC-DC converter with a digitally controlled +1.8V to +4.9V output. The DC-DC converter is unique, since it provides a regulated output for battery inputs that are both less than and greater than the output voltage, without using transformers.
- Three low-noise linear-regulator outputs
- Three DAC-controlled comparators for software-driven, 3-channel A/D conversion
- SPI™-compatible serial interface
- Reset and low-battery (LBO) warning outputs
- Charger for NiCd/NiMH, lithium battery, or storage capacitor for RF PA power or system backup
- Two 1.8Ω (typical), serial-controlled, open-drain MOSFET switches for beeper or vibrator drive

An evaluation kit for the MAX769 (MAX769EVKIT) is available to aid in design and prototyping.

**Pin Configuration appears at end of data sheet.**

### Features

- ◆ Regulated Step-Up/Step-Down Operation
- ◆ 80mA Output from 3 Cells
- ◆ 85% Efficiency
- ◆ 13μA Idle Mode™ (coast) Current
- ◆ Selectable Low-Noise PWM or Low-Current PFM Operation
- ◆ PWM Operating Frequency Synchronized to Seven Times an External Clock Source
- ◆ Operates at 270kHz with No External Clock
- ◆ Automatic Backup-Battery Switchover

### Ordering Information

PART	TEMP. RANGE	PIN-PACKAGE
MAX769EEI	-40°C to +85°C	28 QSOP

### Applications

Two-Way Pagers  
GPS Receivers  
2 or 3-Cell Powered, Hand-Held Equipment

### Typical Operating Circuit

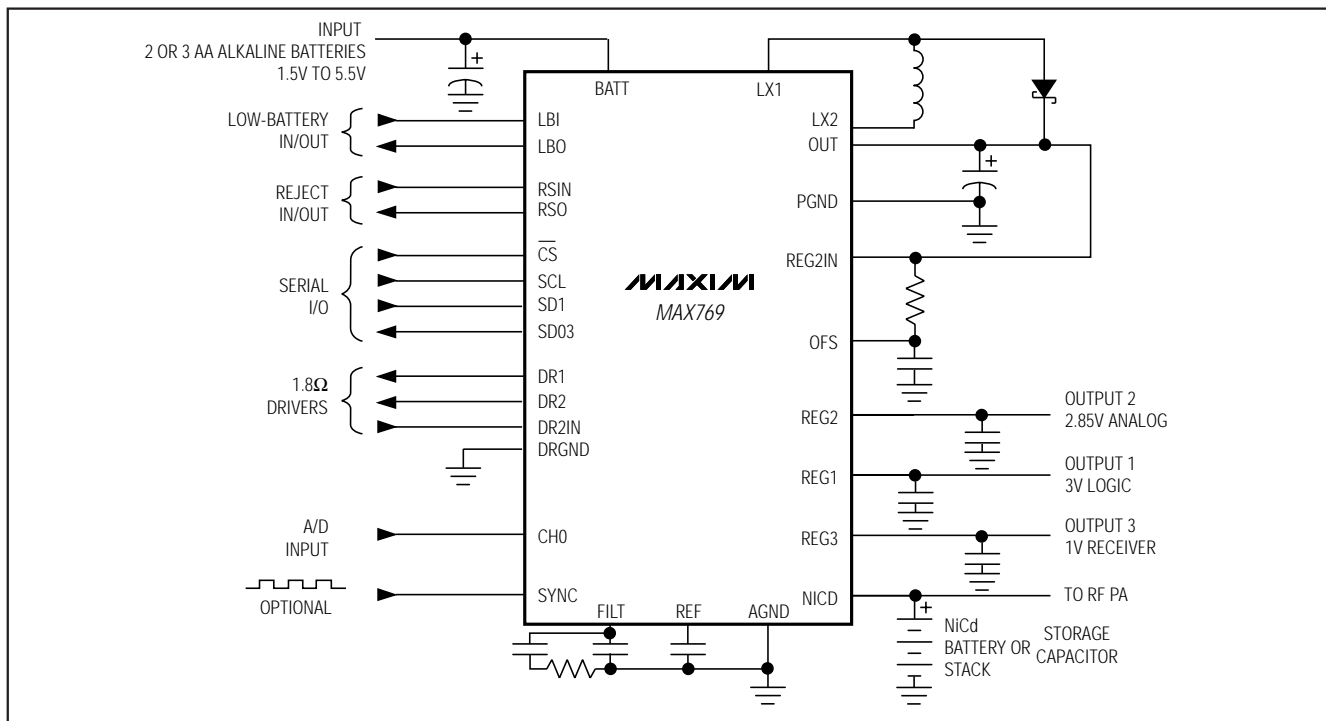

Idle Mode is a trademark of Maxim Integrated Products. SPI is a trademark of Motorola, Inc.

**MAXIM**

Maxim Integrated Products 1

For free samples & the latest literature: <http://www.maxim-ic.com>, or phone 1-800-998-8800.  
For small orders, phone 1-800-835-8769.

# 2 or 3-Cell, Step-Up/Down, Two-Way Pager System IC

## ABSOLUTE MAXIMUM RATINGS

BATT, OUT, NICD, LBO, RSO to AGND.....	-0.3V to +6V	LX2 to PGND.....	-0.3V to (BATT + 0.3V)
REG1, REG2, OFS, REF, R2IN to AGND .....	-0.3V to (OUT + 0.3V)	Continuous Power Dissipation (T <sub>A</sub> = +70°C)	
SCL, SDO, SDI, $\overline{CS}$ , SYNC, FILT, DR2IN, CH0, LBI, RSIN to AGND.....	-0.3V to (REG1 + 0.3V)	QSOP (derate 8mW/°C above +70°C).....	640mW
REG3 .....	-0.3V to (REG2 + 0.3V)	Operating Temperature Range .....	-40°C to +85°C
DR1, DR2 to DRGND .....	-0.3V to (BATT + 0.3V)	Junction Temperature .....	+150°C
PGND, DRGND to AGND .....	-0.3V to +0.3V	Storage Temperature Range .....	-65°C to +165°C
LX1 to PGND .....	-0.3V to (OUT + 0.3V)	Lead Temperature (soldering, 10sec) .....	+300°C

Stresses beyond those listed under "Absolute Maximum Ratings" may cause permanent damage to the device. These are stress ratings only, and functional operation of the device at these or any other conditions beyond those indicated in the operational sections of the specifications is not implied. Exposure to absolute maximum rating conditions for extended periods may affect device reliability.

## ELECTRICAL CHARACTERISTICS

(OUT = 3.0V, BATT = 3.6V, T<sub>A</sub> = -40°C to +85°C, unless otherwise noted. Typical values are at T<sub>A</sub> = +25°C.) (Note 1)

PARAMETER	CONDITIONS		MIN	TYP	MAX	UNITS
<b>GENERAL PERFORMANCE</b>						
BATT Typical Operating Range (Note 2)	Run or Coast Mode		1.5		5.5	V
BATT Minimum Start-Up Voltage (Note 3)	T <sub>A</sub> = +25°C			1.6	2.0	V
Coast Mode Supply Current (Note 4)	REG2, REG3 and CH DAC off, V <sub>OUT</sub> = 2.8V			13	25	μA
Run Mode Supply Current (Note 4)	REG2, REG3 and CH DAC on			875	1350	μA
BATT Supply Current (Note 5)	Coast Mode			4	10	μA
NICD Input Current, Standby (Note 6)	Charger and Backup Modes off, NICD = 3.6V			1.2	3	μA
NICD Input Supply Current, Backup (Note 7)	Backup Mode, NICD = 3.6V, OUT = 3V			20	40	μA
NICD Input Current, Power Fail (Note 8)	Charger and Backup Modes off, BATT = 0V, OUT = 0V			1.2	3	μA
REG2 Supply Current (Note 4)	Incremental supply current when on			50		μA
REG3 Supply Current (Note 4)	Incremental supply current when on			20		μA
CH DAC Supply Current (Note 4)	Incremental supply current when on			30		μA
Reference Voltage	I <sub>REF</sub> = 0 to 20μA, OUT = 1.8V to 4.9V		-1.5%	1.28	1.5%	V
DR1, DR2 On-Resistance	I <sub>DR</sub> = 120mA	T <sub>A</sub> = +25°C		1.8	2.8	Ω
		T <sub>A</sub> = -40°C to +85°C			3.6	
DR1, DR2 Leakage Current	V <sub>DR</sub> = 5V			1	250	nA
SDO Output Low	I <sub>SDO</sub> = 100μA				200	mV
SDO Output High	I <sub>SDO</sub> = -100μA, from REG1		V <sub>REG1</sub> - 0.2			V
Logic Input Level Low	Includes $\overline{CS}$ , SDI, SCL, DR2IN, and SYNC		0.4			V
Logic Input Level High	Includes $\overline{CS}$ , SDI, SCL, DR2IN, and SYNC				V <sub>REG1</sub> - 0.4	V
Logic Input Current	Logic Input = 0 to 3.3V; includes $\overline{CS}$ , SDI, SCL, DR2IN, and SYNC		-1		1	μA

# 2 or 3-Cell, Step-Up/Down, Two-Way Pager System IC

MAX769

## ELECTRICAL CHARACTERISTICS (continued)

(OUT = 3.0V, BATT = 3.6V, T<sub>A</sub> = -40°C to +85°C, unless otherwise noted. Typical values are at T<sub>A</sub> = +25°C.) (Note 1)

PARAMETER	CONDITIONS	MIN	TYP	MAX	UNITS	
<b>SERIAL-INTERFACE TIMING SPECIFICATIONS</b> (Note 9)						
SCL Maximum Clock Rate	50% duty cycle	5			MHz	
SDI Setup Time (t <sub>DS</sub> )		100			ns	
SDI Hold Time (t <sub>DH</sub> )		50			ns	
SCL to SDO Output Valid (t <sub>DO</sub> )				70	ns	
$\overline{\text{CS}}$ to SDO Output Valid (t <sub>DV</sub> )				70	ns	
$\overline{\text{CS}}$ to SDO Disable (t <sub>TR</sub> )				70	ns	
$\overline{\text{CS}}$ to SCL Setup Time (t <sub>CS</sub> )		50			ns	
$\overline{\text{CS}}$ to SCL Hold Time (t <sub>CSH</sub> )		50			ns	
$\overline{\text{CS}}$ Pulse Width High (t <sub>CSW</sub> )		100			ns	
SCL Pulse Width High or Low (t <sub>CH</sub> , t <sub>CL</sub> )		50			ns	
<b>DC-DC CONVERTER</b>						
Output Current, Run Mode (Note 10)	Circuit of Figure 2, OUT = 3.0V, BATT = 3.0V	80	115		mA	
Output Current, Coast Mode (Note 10)	Circuit of Figure 2, OUT = 3.0V, BATT = 3.0V	15	40		mA	
OUT Error, Coast Mode (Note 11)	Coast Mode, OUT = 1.8V to 4.9V	-3.5		3.5	%	
OUT Error, Run Mode (Note 12)	Run Mode, OUT = 1.8V to 4.9V	-3.5		3.5	%	
OUT DAC Step Size (Note 13)	Coast or Run Mode, OUT = 1.8V to 4.9V	30	100	170	mV	
OUT Load Regulation	I <sub>OUT</sub> = 1mA to 80mA, Run Mode		25		mV	
OUT Line Regulation	BATT = 1.6V to 4.5V		25		mV	
Maximum LX Duty Cycle	OUT = 3.0V	76	83		%	
OUT Voltage Ripple	I <sub>OUT</sub> = 80mA, C <sub>OUT</sub> = 47μF with ESR < 0.25Ω		70		mVp-p	
LX Switch Current Limit	During the inductor charge cycle	300	350	400	mA	
LX On-Resistance (Note 14)	LX1, LX2, BATT = 3.0V	NMOS		0.9	1.8	Ω
		PMOS		1.3	2.6	
<b>PHASE-LOCKED LOOP (PLL)</b>						
Frequency, Free-Run	T <sub>A</sub> = +25°C, FILT connected to REF	210	270	325	kHz	
Frequency, Locked	f <sub>SYNC</sub> = 38.4kHz		268.8		kHz	
Jitter (Note 15)	f <sub>SYNC</sub> = 38.4kHz, FILT Network = 1nF    (22nF + 10kΩ)		±15		kHz	
Capture Time (Note 15)	f <sub>SYNC</sub> = 38.4kHz, FILT Network = 1nF    (22nF + 10kΩ)		1	25	ms	
<b>NICD CHARGER</b>						
Current High	0.2V < (OUT - NICD) < 2V, 15mA_CHG = 1	7		25	mA	
Current Low	0.2V < (OUT - NICD) < 2V, 1mA_CHG = 1	0.45		1.5	mA	
OUT Error, Backup Regulator	OUT = 2.8V, I <sub>OUT</sub> = 20mA, NICD = 3.3V	-3.5		3.5	%	
Backup-Regulator On-Resistance (Note 16)	Backup Mode, NICD = 3.3V		5	10	Ω	

## 2 or 3-Cell, Step-Up/Down, Two-Way Pager System IC

### ELECTRICAL CHARACTERISTICS (continued)

(OUT = 3.0V, BATT = 3.6V, T<sub>A</sub> = -40°C to +85°C, unless otherwise noted. Typical values are at T<sub>A</sub> = +25°C.) (Note 1)

PARAMETER	CONDITIONS	MIN	TYP	MAX	UNITS	
<b>LINEAR REGULATORS</b>						
REG1 PMOS On-Resistance	OUT = 3.0V, I <sub>REG1</sub> = 65mA		1.5	3.1	Ω	
REG1 Supply Rejection (Note 16)	f = 268.8kHz, C <sub>REG1</sub> = 10μF ceramic	15	25		dB	
REG1 Clamp Voltage	I <sub>OUT</sub> = 1mA, OUT = 4.9V	T <sub>A</sub> = +25°C	3.2	3.3	3.4	V
		T <sub>A</sub> = -40°C to +85°C	3.15		3.45	
REG2 Voltage Drop	I <sub>REG2</sub> = 0 to 24mA, OUT = 3.0V, R <sub>OFS</sub> = 15kΩ	120	155	190	mV	
REG2 Load Regulation	I <sub>REG2</sub> = 0.1mA to 24mA		9		mV	
REG2 Supply Rejection (Note 16)	f = 268.8kHz, C <sub>REG1</sub> = 10μF, ceramic, R <sub>OFS</sub> = 15kΩ, C <sub>OFS</sub> = 0.1μF, I <sub>REG2</sub> = 15mA	30	40		dB	
REG3 Output Voltage	I <sub>REG3</sub> = 0 to 2mA	0.96	1.0	1.04	V	
REG3 Supply Rejection (Note 16)	f = 268.8kHz, C <sub>REG1</sub> = 1μF ceramic	40	50		dB	
<b>DATA-ACQUISITION AND VOLTAGE MONITORS</b>						
LBI/RSIN Input Threshold	Falling input	0.58	0.60	0.63	V	
LBI/RSIN Input Hysteresis (Note 16)		7.5	16	30	mV	
LBI/RSIN Input Current		-50	-3	50	nA	
LBO/RSO Output Low	I <sub>OUT</sub> = 1mA		30	400	mV	
LBO/RSO Output Leakage	Output = 5.5V		1	250	nA	
LBO/RSO Response Time (Note 16)	10mV overdrive		15	50	μs	
CH0 Threshold Range (Note 16)		0.2		1.27	V	
CH1 Threshold Range (Note 16)	Measures NICD	1.2		5.08	V	
CH2 Threshold Range (Note 16)	Measures BATT	1.2		5.08	V	
CH0 Threshold Resolution (Note 16)			10		mV	
CH1 Threshold Resolution (Note 16)	Measures NICD		40		mV	
CH2 Threshold Resolution (Note 16)	Measures BATT		40		mV	
CH0 Error	At thresholds of 200mV, 800mV, and 1270mV	-2.0 - 15mV		2.0 + 15mV	%	
CH1 Error	At thresholds of 1200mV, 3200mV, and 5080mV	-3.0 - 60mV		3.0 + 60mV	%	
CH2 Error	At thresholds of 1200mV, 3200mV, and 5080mV	-3.0 - 60mV		3.0 + 60mV	%	
CH0 Input Hysteresis (Note 16)		1	2	4	mV	
CH1 Input Hysteresis (Note 16)		4	8	16	mV	

# 2 or 3-Cell, Step-Up/Down, Two-Way Pager System IC

MAX769

## ELECTRICAL CHARACTERISTICS (continued)

(OUT = 3.0V, BATT = 3.6V, T<sub>A</sub> = -40°C to +85°C, unless otherwise noted. Typical values are at T<sub>A</sub> = +25°C.) (Note 1)

PARAMETER	CONDITIONS	MIN	TYP	MAX	UNITS
CH2 Input Hysteresis (Note 16)		4	8	16	mV
CH0 Input Current	CH0 = 0.2V to 1.27V	-100		100	nA
CH Comparator Response Time (Note 16)	10mV overdrive		0.6	1.0	μs

- Note 1:** Specifications to -40°C are guaranteed by design, not production tested.
- Note 2:** This is not a tested parameter, since the IC is powered from OUT, not BATT.
- Note 3:** Minimum start-up voltage is tested by determining when the LX pins can draw at least 15mA for 0.5μs (min) at a 285kHz (min) repetition rate. This guarantees that the IC will deliver at least 200μA at the OUT pin.
- Note 4:** This supply current is drawn from the OUT pin. Current drain from the battery depends on voltages at BATT and OUT and on the DC-to-DC converter's efficiency.
- Note 5:** Current into BATT pin in addition to the supply current at OUT. This current is roughly constant from Coast to Run Mode.
- Note 6:** Current into NICD pin when NICD isn't being charged and isn't regulating OUT.
- Note 7:** Current into NICD pin when NICD is regulating OUT. Doesn't include current drawn from OUT by the rest of the circuit. Measured by setting the OUT regulation point to 2.8V and holding OUT at 3.0V.
- Note 8:** Current into the NICD pin when BATT and OUT are both at 0V. This test guarantees that NICD won't draw significant current when the main battery is removed and backup is not activated.
- Note 9:** Serial-interface timing specifications are not tested and are provided for design guidance only. Serial-interface functionality is tested by clocking data in at 5MHz with a 50% duty-cycle clock and checking for proper operation. With OUT set below 2.5V, the serial-interface clock frequency should be reduced to 1MHz to ensure proper operation.
- Note 10:** This specification is not directly tested but is guaranteed by correlation to LX on-resistance and current-limit tests.
- Note 11:** Measured by using the internal feedback network and Coast-Mode error comparator to regulate OUT. Doesn't include ripple voltage due to inductor currents.
- Note 12:** Measured by using the internal feedback network and Run-Mode error comparator to regulate OUT. Doesn't include ripple voltage due to inductor currents.
- Note 13:** Uses the OUT measurement techniques described for the OUT error, Coast Mode, and OUT error Run Mode specifications.
- Note 14:** The on-resistance is for either LX1 or LX2.
- Note 15:** PLL acquisition characteristics depend on the impedance at the FILT pin. The specification is not tested and is provided for design guidance only.
- Note 16:** The limits in this specification are not guaranteed and are provided for design guidance only.

## Typical Operating Characteristics

(T<sub>A</sub> = +25°C, unless otherwise noted.)

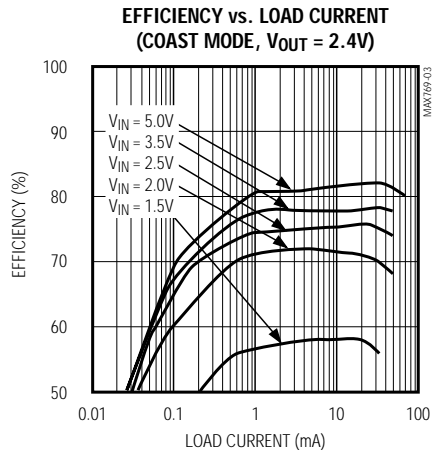
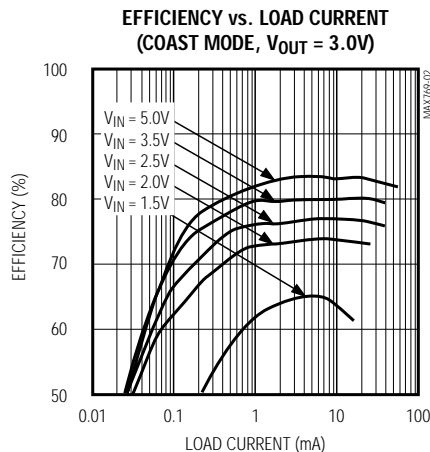
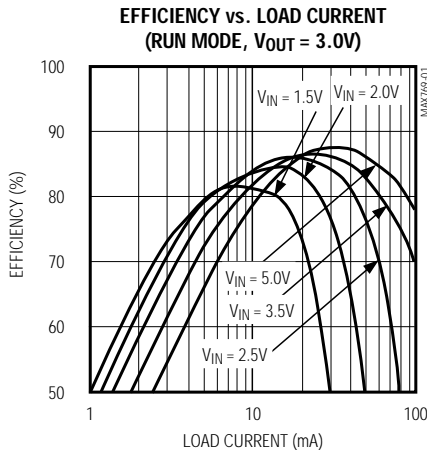

# 2 or 3-Cell, Step-Up/Down, Two-Way Pager System IC

## Typical Operating Characteristics (continued)

(T<sub>A</sub> = +25°C, unless otherwise noted.)

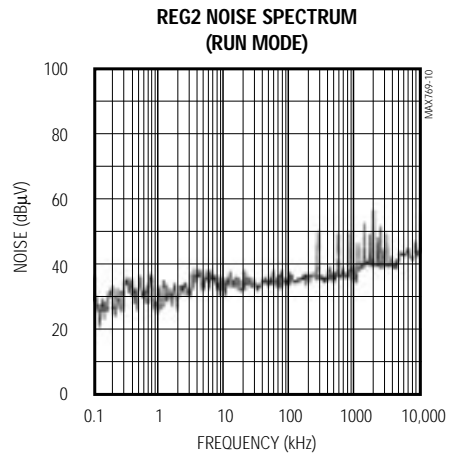
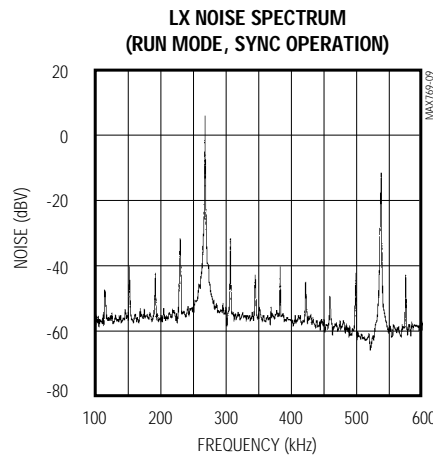
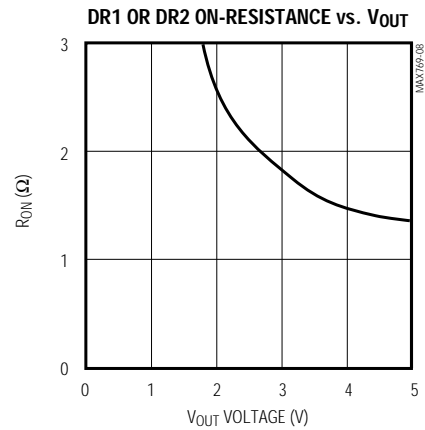
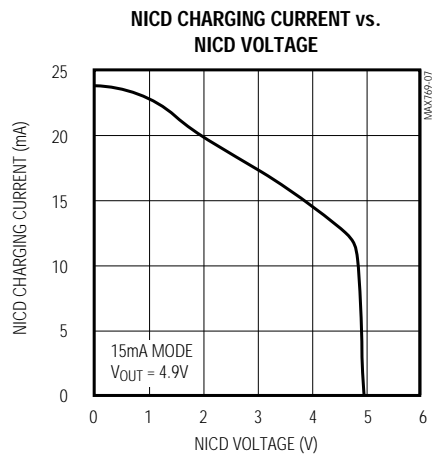
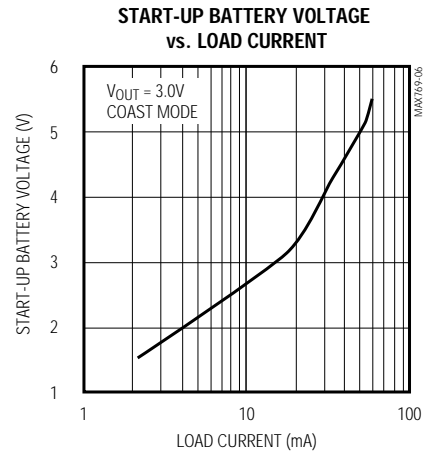
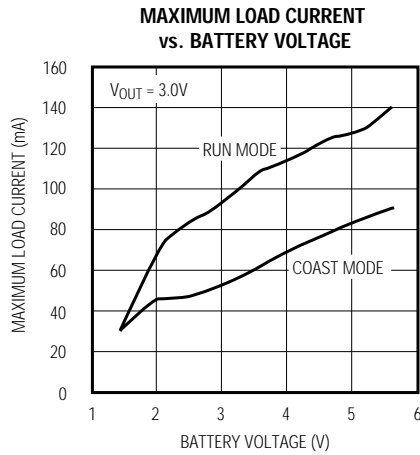
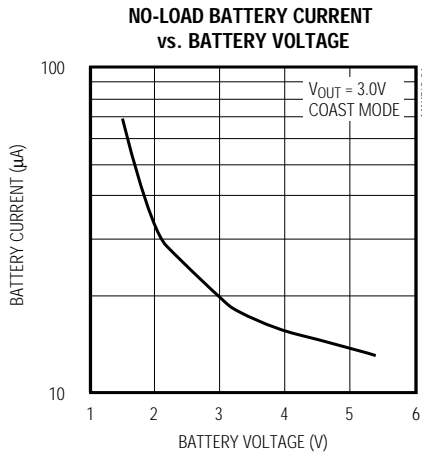

# 2 or 3-Cell, Step-Up/Down, Two-Way Pager System IC

## Pin Description

MAX769

PIN	NAME	FUNCTION
1	LX1	Connect LX1 to the inductor. LX1 is internally connected to an NFET that switches to PGND and a PFET that switches to OUT.
2	SDI	Serial Data Input for SPI Interface
3	SDO	Serial Data Output for SPI Interface
4	PGND	Power Ground. Source of LX1 and LX2 NFETs.
5	SCL	Serial Clock for SPI Interface
6	LBO	Open-Drain Output for LBI Comparator
7	RSO	Reset Output. Open drain goes low when RSIN drops below 0.6V. All serial registers are reset (or set) to POR state as well.
8	REF	1.28V Reference. Bypass with a 1 $\mu$ F capacitor.
9	CH0	CH0 is compared to a 7-bit DAC that adjusts from 0.2V to 1.27V. The comparison result is sent to the CH0 OUT register.
10	RSIN	Reset Input. Triggers RSO and resets IC when input is below 0.6V. Comparator with hysteresis (18mV).
11	LBI	Low-Battery Input. Triggers LBO and internal serial bit.
12	FILT	An external RC network sets the PLL loop response to adjust frequency lock time versus jitter: 1nF    (22nF + 10k $\Omega$ ).
13	SYNC	Sync Input for PWM Switch Rate. A 38.4kHz input results in a 268.8kHz PWM rate (seven times the SYNC frequency).
14	OFS	Resistor sets offset between OUT (or REG1 or any other point) and REG2. R <sub>OFS</sub> = 15k $\Omega$ results in 150mV.
15	AGND	Analog Ground
16	DRGND	Ground for DR1 and DR2 FET Sources
17	DR1	Open-Drain FET Switch. Activated via the serial-interface bit.
18	DR2IN	Logic Input. ANDed with the DR2ON bit to control the DR2 switch.
19	DR2	Open-Drain FET Switch. On via AND of the DR2ON bit and the DR2IN pin.
20	REG3	1V, 2mA Regulator Output. On via the serial interface. Low noise.
21	REG2	24mA REG2 Output. Linearly regulated to the voltage at the OFS pin (voltage difference = 10 $\mu$ A x R <sub>OFS</sub> ). REG2 isolates noise.
22	R2IN	REG2 Input. Connect to OUT, REG1, or another voltage source.
23	NICD	15mA or 1mA Settable Charge Current from OUT to 3-Cell NiCd Stack. When the NICD_REG_ON bit is set (Table 1), NICD becomes an input to the linear regulator at OUT, and the DC-DC converter is off.
24	REG1	PFET Output Connected to OUT. Output is clamped such that it cannot rise above 3.3V, regardless of the voltage set at OUT.
25	OUT	DC-DC Converter Output and Feedback Point. Digitally controlled from 1.8V to 4.9V in 100mV steps (Table 5).
26	BATT	Positive Connection to Battery. The IC is powered from OUT.
27	$\overline{\text{CS}}$	Chip Select for SPI Serial Interface
28	LX2	Connect LX2 to the other inductor terminal. LX2 is internally connected to an NFET that switches to PGND and a PFET that switches to BATT.

# 2 or 3-Cell, Step-Up/Down, Two-Way Pager System IC

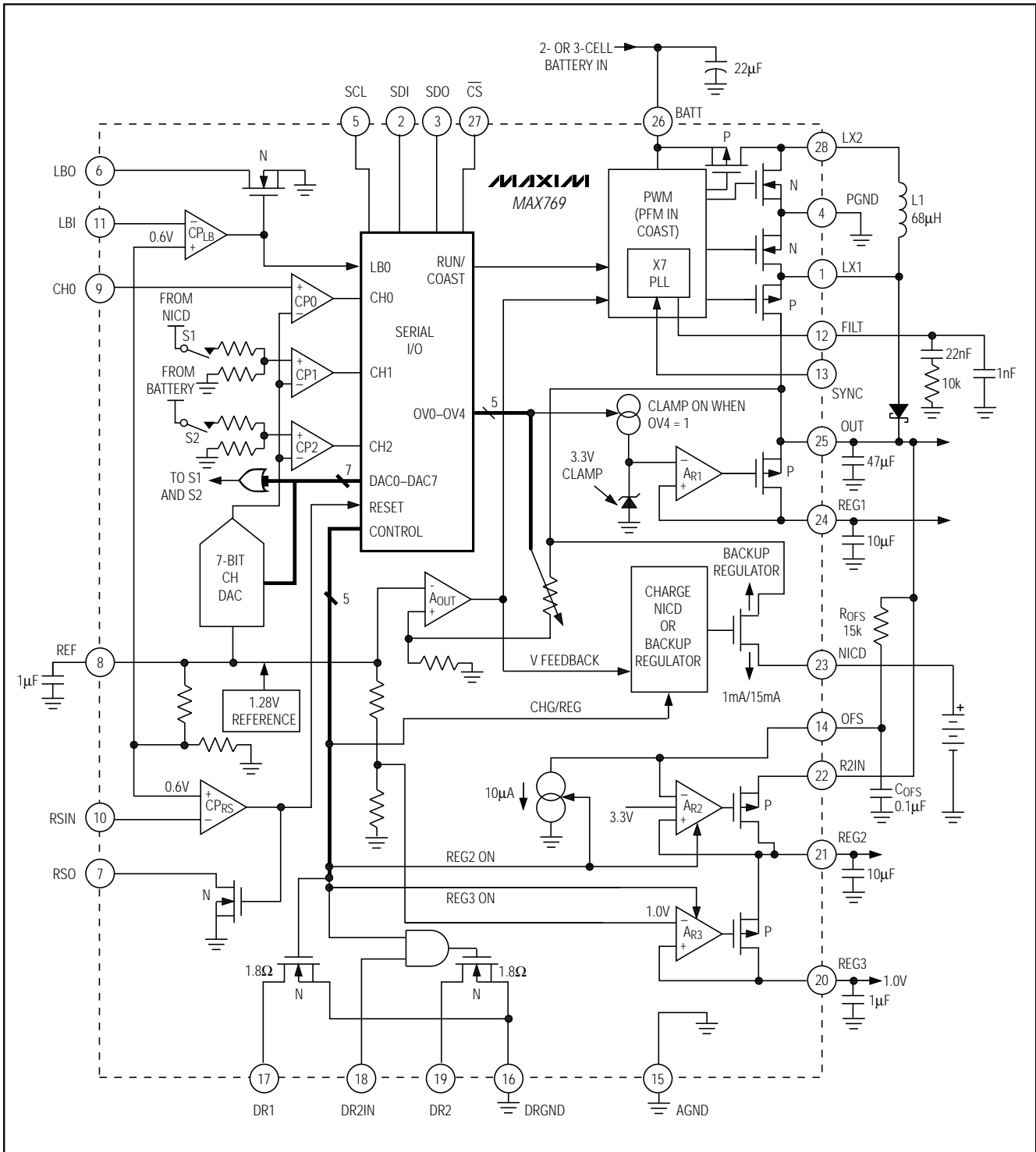

Figure 1. MAX769 Block Diagram



# 2 or 3-Cell, Step-Up/Down, Two-Way Pager System IC

## Detailed Description

The MAX769 contains several functional blocks that simplify the integration of power-supply and monitoring functions within a 2 or 3-cell powered system. They are described in the following subsections.

### Voltage Regulators

Regulator outputs include the following:

- OUT: Main switch-mode buck/boost output
- REG1: 1.5Ω switch and output voltage clamp. Switches REG1 to OUT and clamps REG1 at 3.3V when OUT is set to 3.4V or more.
- REG2: Linear-regulated, 24mA low-noise output that regulates so that  $V_{OUT} - V_{REG2}$  is a set difference voltage ( $10\mu\text{A} \times R_{OFS}$ ). Output peak-to-peak ripple is typically 2mV with a 10μF bypass capacitor at REG2. REG2 clamps the output at 3.3V when OUT is set to 3.4V or more.
- REG3: Low-noise, 1V linear regulator that supplies 2mA.

### Main DC-DC Boost Converter (OUT)

OUT is the main DC-DC converter's output. It supplies current from the internal synchronous-rectified buck/boost regulator and needs no external FETs or voltage-setting resistors. The output voltage ( $V_{OUT}$ ) is adjusted from 1.8V to 4.9V in 100mV steps (Tables 1 and 5) by internal DAC control using a serial-data command. OUT can supply up to 80mA, less the current supplied to the other regulators (REG1, REG2, and REG3).

OUT can also be put into a low-current, pulse-skipping Coast Mode (13μA typical quiescent current) by resetting the RUN/COAST serial input bit. OUT supplies up to 40mA in Coast Mode. Typically, when changing from Run to Coast Mode, a lower OUT voltage is also set (Table 4) to further reduce system operating current. The extent of this reduction depends on the minimum operating voltage of the system components when they are in standby or sleep states.

OUT can be set as low as 1.8V; however, some Run Mode functions are limited when  $V_{OUT}$  is below 2.5V:

- The allowed serial-interface clock rate is reduced.
- Internal LX FET and DR1 and DR2 on-resistance increases.

### Logic Supply (REG1)

REG1 is not a regulator in the conventional sense, but rather a 1.5Ω PFET that acts as either a switch or a voltage clamp, depending on the programmed OUT voltage. When OUT is set to 3.3V or less, REG1 operates as a switch. When OUT is set to 3.4V or more, the

REG1 output clamps at 3.3V. This arrangement limits  $V_{REG1}$  to an acceptable voltage for logic when OUT is programmed to a higher voltage (typically >4V) for charging (see *Charger Circuit* and *Backup Linear Regulator* sections).

### Low-Noise Analog Supply (REG2)

REG2 is a linear, 24mA low-dropout regulating circuit whose input is R2IN. The REG2 output ( $V_{REG2}$ ) is set by  $R_{OFS}$ .  $R_{OFS}$  does not set an absolute voltage, but rather an offset level from R2IN (Figure 2).  $V_{REG2}$  is set by:

$$V_{REG2} = V_{R2IN} - 10\mu\text{A} \times R_{OFS}$$

Typically R2IN and  $R_{OFS}$  are tied to OUT, in which case:

$$V_{OUT} - V_{REG2} = 10\mu\text{A} \times R_{OFS}$$

$R_{OFS}$  adjusts  $V_{REG1} - V_{REG2}$  to allow REG2 noise rejection to be traded for voltage drop and consequent efficiency loss. A 15kΩ (typical)  $R_{OFS}$  value sets a 150mV voltage difference. R2IN is typically supplied from OUT or REG1, but can be connected elsewhere as long as the voltage applied to R2IN does not exceed  $V_{OUT}$ . For lowest output noise on REG2, connect R2IN to REG1.

Note that the REG2 output also clamps at 3.3V when OUT is set to 3.4V or higher.

### Low-Noise, 1V Analog Supply (REG3)

REG3 is a 1V, low-noise linear regulator that supplies up to 2mA. REG3's input is internally connected to REG2.

### PWM Frequency Synchronization

The DC-DC converter switching frequency in pulse-width-modulation (PWM) mode is nominally 270kHz if no synchronization clock is supplied and FILT is tied to REF. If the PLL is used, a filter network is connected to FILT, a clock is applied to SYNC, and the internal oscillator locks to seven times the input clock rate. The MAX769 is designed for a 38.4kHz SYNC input and hence a 268.8kHz operating frequency. PWM switching frequency is unaffected by the serial-data clock rate.

### Voltage Detectors (LBO and Reset)

The MAX769 contains two voltage-detector inputs: LBI and RSIN. The LBI and RSIN comparator outputs are open-drain pins (LBO and RSO) for a real-time hardware output. LBO is also readable via the serial interface. Both LBI and RSIN trigger at a 0.6V input threshold and have about 18mV hysteresis. RSO also triggers the MAX769 internal power-on reset (POR).

## 2 or 3-Cell, Step-Up/Down, Two-Way Pager System IC

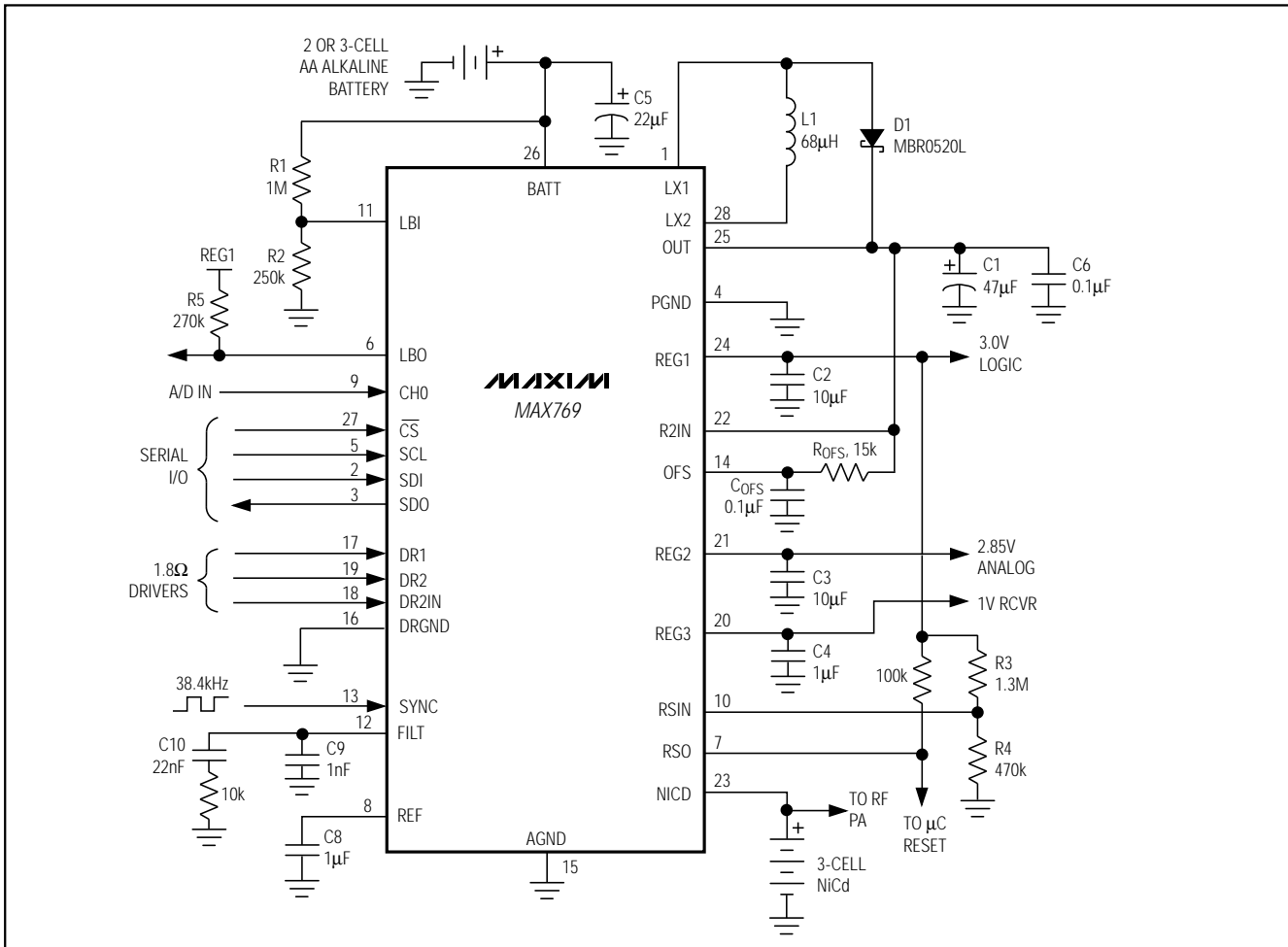

Figure 2. Standard Application Circuit

### 7-Bit ADC (CH0 Input and CH1, CH2)

Three analog channels are compared to a 7-bit, serially programmed digital-to-analog converter (CH DAC). The CH DAC voltage can be varied in 10mV steps from 200mV to  $V_{REF} - 1\text{LSB}$  (or 1.27V) (Table 1). CH0 is an external input, while CH1 and CH2 are signals internally generated from the NICD and BATT pins. NICD and BATT are internally divided by four before being compared to CH DAC. The comparison threshold voltages for each channel are described in the following equations:

$$V_{TH} (\text{CH0: pin 9}) = D \times 10\text{mV}$$

$$V_{TH} (\text{CH1: NICD}) = D \times 40\text{mV}$$

$$V_{TH} (\text{CH2: BATT}) = D \times 40\text{mV}$$

where D is the decimal equivalent of the binary code DAC0–DAC6 (Table 1). DAC0 is the LSB. A DAC code of 1111111 equates to  $D = 127$ . When all zeros are programmed, the CH DAC and CH\_ comparators turn off.

CH0, CH1, and CH2 comparison results reside in the three MSB locations of the output serial data (Table 4). The CH\_ OUT data is delayed by one read cycle. In other words, each CH\_ OUT bit is the result of the comparison made against the CH DAC voltage programmed during the previous serial-write operation.

An analog-to-digital (A/D) conversion can be performed on a channel by using the system software to step through a successive-approximation routine or, if the input is partially known, by setting the CH DAC to a voltage near the estimated point and checking successive CH\_ OUT bits.

# 2 or 3-Cell, Step-Up/Down, Two-Way Pager System IC

A faster A/D shortcut can be used for battery measurements when the goal is a “go, no go” determination. For this type of test, the CH DAC can simply be set to the desired limit, and CH\_ OUT supplies the result on the next serial-write operation. One instance in which this shortcut saves time is during a battery-impedance check. The unloaded battery voltage can first be measured, if time allows, using one of the techniques described in the previous paragraph. Then the magnitude of the loaded voltage drop can be quickly checked with a single comparison to see if it is within the desired limit.

The A/D circuitry can be invoked in both Run and Coast Modes.

### Open-Drain Drivers

Two open-drain drivers (DR1 and DR2) are activated via the serial interface. DR1 and DR2 are grounded 1.8 $\Omega$  (typical) NFETs that can sink up to 120mA. The maximum sink current is limited by on-resistance and package dissipation to about 240mA total sink current for both switches. Note that DR1 and DR2 are designed to sink current only from the main battery (BATT) and cannot be pulled above BATT.

DR2 is controlled by an external input (DR2IN) as well as a serial input bit. DR2IN is ANDed with the DR2ON serial-control bit, allowing DR2 to drive an audio beeper. The audio-frequency clock is applied to DR2IN, and ON/OFF gating is applied to DR2ON. Both DR2IN (pin 18) and DR2ON (serial bit) must be high for DR2 to switch on.

### Coast Mode/Voltage Selection

Reduce the operating current by setting the RUN/COAST bit low via the serial input. This shifts the DC-DC boost converter from low-noise PWM operation (Run Mode) to a very low operating current mode (Coast Mode) in which switching pulses are only provided as needed to satisfy the load. To further reduce operating current in Coast Mode, lower  $V_{OUT}$  using the OV0–OV4 serial bits. The MAX769 starts up in Coast Mode. Select Run Mode with the serial interface after power-up.

Various circuit functions can be disabled as follows:

Functions that *always remain on in Coast Mode* are:

- Serial I/O
- Reference (REF)
- OUT
- REG1
- LBI, RSIN (and LBO, RSO)

Functions that can be *programmed on or off in Coast Mode* are (Table 1):

- DR1 and DR2
- REG2 and REG3
- NICD charger (Note: This may overload OUT if turned on in Coast Mode when other loads are present)
- Backup regulator
- CH0, CH1, CH2, and CH DAC

Functions that *always turn off in Coast Mode* are:

- SYNC and PLL circuits
- DC-DC PWM control circuits

### Power-On Reset

The MAX769 has an internal POR circuit ( $V_{OUT} < 1.6V$ ) to ensure an orderly power-up when a battery is first applied. This feature is separate from the RSO comparator; however, if RSO goes low during operation, all serial registers are set to the same predetermined states as on power-up. The POR states for each register are listed in Table 2.

Note that the MAX769 always comes out of reset in Coast Mode; consequently, it cannot supply full power until Run Mode is selected by serial command. System software cannot exercise full load current until Run Mode is enabled.

### Charger Circuit

A charger current source from OUT to NICD is activated via a serial bit (Table 1). The current source can charge a small 3-cell NiCd or NiMH battery (typically a coin cell) or a 1-cell lithium battery. The charge current can be set to either 15mA or 1mA. OUT sets the maximum charge (or float) voltage. When charging is implemented,  $V_{OUT}$  must also be set high enough to allow sufficient headroom for the charger current source. The  $V_{OUT} - V_{NICD}$  difference should normally be between 0.2V and 0.5V. Charger current vs. NICD voltage is graphed in the *Typical Operating Characteristics*. Note also that charging current reduces the OUT current available for other loads.

### Backup Linear Regulator

The BACKUP serial input bit turns on the backup regulator, which sources current from NICD to OUT. This regulator backs up OUT by using the rechargeable battery (at NICD) when the main battery (at BATT) is depleted or removed. The backup regulator pass device's resistance is typically 5 $\Omega$ , so it can typically supply 20mA with only 100mV of dropout.

## 2 or 3-Cell, Step-Up/Down, Two-Way Pager System IC

**Table 1. Serial-Bit Assignments**

R2 (MSB)	R1	R0	D4	D3	D2	D1	D0
0	0	0	DR2_ON	DR1_ON	REG3_ON	REG2_ON	RUN/ COAST
0	0	1	X	LBO_Sets_ BACKUP	BACKUP	15mA_CHG	1mA_CHG
0	1	0	OV4	OV3	OV2	OV1	OV0
0	1	1	X	X	X	X	X
1	DAC6	DAC5	DAC4	DAC3	DAC2	DAC1	DAC0

**Table 2. Serial-Bit Power-On Reset (POR) States**

R2	R1	R0	D4	D3	D2	D1	D0
0	0	0	POR = 0	POR = 0	POR = 0	POR = 0	POR = 0
0	0	1	X	POR = 0	POR = 0	POR = 0	POR = 0
0	1	0	POR = 0	<b>POR = 1</b>	<b>POR = 1</b>	POR = 0	POR = 0
0	1	1	X	X	X	X	X
1	POR = 0	POR = 0	POR = 0	POR = 0	POR = 0	POR = 0	POR = 0

**Table 3. Input-Bit Function Description**

INPUT BIT	FUNCTION
RUN/COAST	1 = Run Mode, 0 = Coast Mode (POR state is Coast Mode).
REG2_ON, REG3_ON	1 = Turns on the selected regulator (POR state is off).
DR1, DR2	1 = Turns on the selected switch (POR state is off).
1mA_CHG, 15mA_CHG	1 = Turns on the selected charge current to NICD. If both are set, the charge current is 15mA (POR state is off).
BACKUP	1 = Turns on the backup linear regulator from NICD to OUT and disables the DC-DC converter (POR state is BACKUP off). Setting this bit overrides 1mA_CHG, 15mA_CHG, and LBO_Sets_BACKUP (Figure 1).
LBO_Sets_BACKUP	1 = Allows LBO to turn on the backup regulator and disable the DC-DC converter (POR state is no connection between LBO and BACKUP).
OV0–OV4	Sets OUT Output Voltage (POR state is $V_{OUT} = 3.0V$ ).
DAC0–DAC6	Sets 7-bit CH DAC voltage for A/D conversion (POR state is all zeros with DAC and comparators off).

**Table 4. Serial Output Data**

D7 (MSB)	D6	D5	D4	D3–D0	FUNCTION
CH2_OUT	CH1_OUT	CH0_OUT	LBO	X	CH_OUT and LBO output bits. A 1 indicates that the selected channel (CH_) voltage is greater than the CH DAC voltage or that LBI is less than 0.6V.

# 2 or 3-Cell, Step-Up/Down, Two-Way Pager System IC

MAX769

**Table 5. V<sub>OUT</sub> Output Voltage**

SERIAL-DATA BIT					V <sub>OUT</sub> (V)
OV4	OV3	OV2	OV1	OV0	
0	0	0	0	0	1.8
0	0	0	0	1	1.9
0	0	0	1	0	2.0
0	0	0	1	1	2.1
0	0	1	0	0	2.2
0	0	1	0	1	2.3
0	0	1	1	0	2.4
0	0	1	1	1	2.5
0	1	0	0	0	2.6
0	1	0	0	1	2.7
0	1	0	1	0	2.8
0	1	0	1	1	2.9
0	1	1	0	0	3.0
0	1	1	0	1	3.1
0	1	1	1	0	3.2
0	1	1	1	1	3.3
1	0	0	0	0	3.4
1	0	0	0	1	3.5
1	0	0	1	0	3.6
1	0	0	1	1	3.7
1	0	1	0	0	3.8
1	0	1	0	1	3.9
1	0	1	1	0	4.0
1	0	1	1	1	4.1
1	1	0	0	0	4.2
1	1	0	0	1	4.3
1	1	0	1	0	4.4
1	1	0	1	1	4.5
1	1	1	0	0	4.6
1	1	1	0	1	4.7
1	1	1	1	0	4.8
1	1	1	1	1	4.9

All DC-DC converter and charging circuitry is disabled when the backup regulator is turned on, but all other functions remain active. Activate BACKUP manually or by serial command, or set it to trigger automatically via LBO.

### Automatic Backup

Setting the LBO\_Sets\_BACKUP serial bit (Table 1) programs the IC so that when LBO goes low, the backup regulator automatically turns on without instructions from the microprocessor (μP). When the LBO\_Sets\_BACKUP bit is 0, the backup regulator is turned on only by setting the BACKUP bit. The BACKUP bit also overrides the LBO\_Sets\_BACKUP bit. Figure 3 shows the logic for this function.

If the main battery is depleted and the NiCd battery is drained during backup, RSO goes low while the backup regulator is supplying OUT (if RSI is used to monitor OUT or REG1). When RSO falls, the serial registers reset to their POR states (with the DC-DC converter on in Coast Mode and the backup regulator off, see Tables 1, 2, and 3). This prevents the IC from getting hung up with the DC-DC converter off when a new main battery is inserted. This sequence is required because if the MAX769 did not default to “DC-DC converter on” when coming out of reset, the μP (still reset by RSO) would not be able to provide the device with serial instructions to turn on.

### Serial Interface

The MAX769 has an SPI-compatible serial interface. The serial-interface lines are Chip Select (CS), Serial Clock (SCL), Serial Data In (SDI), and Serial Data Out (SDO). Serial input data is arranged in 8-bit bytes. Most bytes contain a 3-bit address pointer (R2, R1, R0) along with 5 bits of input data (D4–D0). For common operations such as selecting Run or Coast Mode, activating REG2 or REG3, or turning on DR1 or DR2, only the 000 (R2, R1, R0) address register needs to be written. The serial input data format for all MAX769 operations is outlined in Tables 1, 2, and 3.

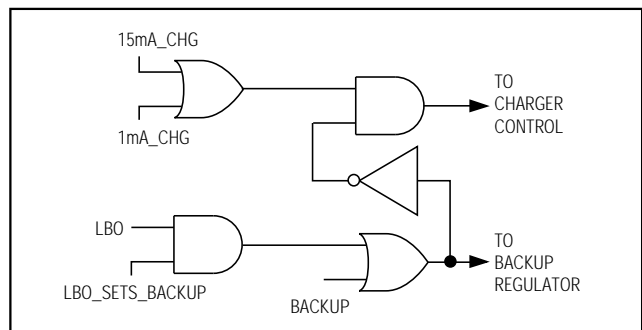

Figure 3. Logic for Charger Control and BACKUP and for LBO\_Sets\_BACKUP Serial Input Bits

# 2 or 3-Cell, Step-Up/Down, Two-Way Pager System IC

Serial data is clocked in and out MSB first. Input data is latched on the CLK rising edge, and output data is shifted out on the CLK falling edge. When  $\overline{CS}$  goes low, DO immediately contains the MSB output bit (D7). D6 is not clocked out until the falling clock edge that follows the first rising clock edge after a Chip Select. See the timing diagrams in Figures 4 and 5.

SPI writes and reads concurrently, so it may be necessary to perform dummy writes in order to read output data. Four output data bits (D7–D4, Table 4) are sent from SDO each time a serial operation occurs.

When  $R2 = 0$ ,  $R0$  and  $R1$  are address pointers. However, when  $R2 = 1$ , the 7 remaining bits ( $R1$ ,  $R0$  and  $D4$ – $D0$ ) become DAC programming bits. This violation of programming etiquette ( $R1$  and  $R0$  are sometimes address bits and other times data bits) allows the CH DAC to be loaded with only one write operation.

Writing all zeros to the CH DAC turns it, the CH0, CH1, and CH2 comparators, and the NICD and BATT voltage-sensing resistors off to minimize current consumption. This reduces current drain from OUT by about 30 $\mu$ A.

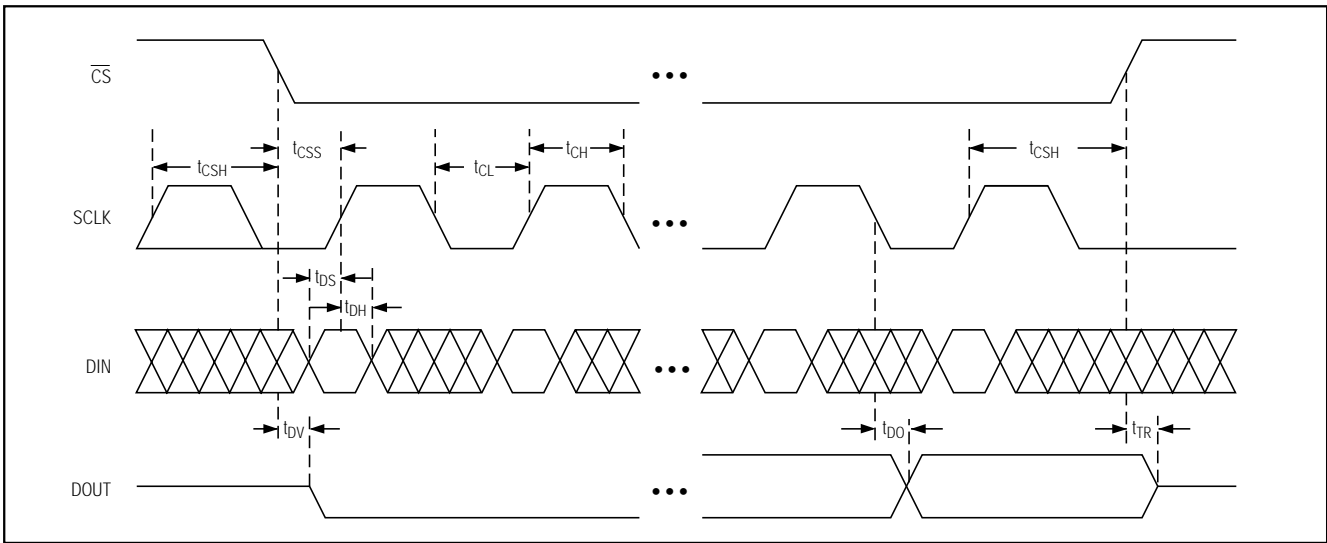

Figure 4. Detailed Serial-Interface Timing

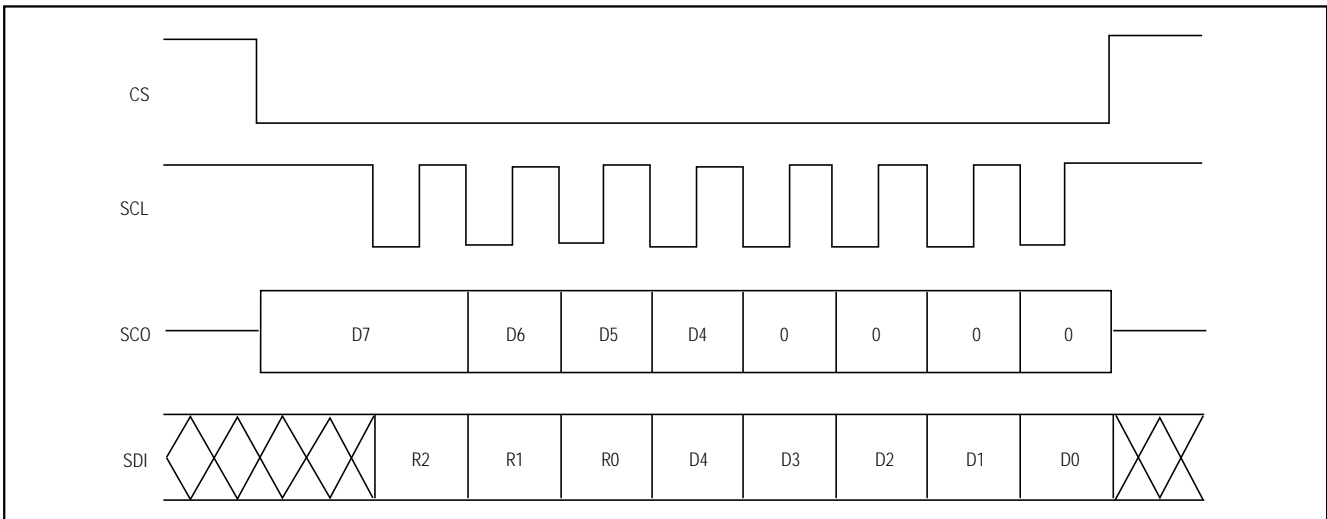

Figure 5.  $\overline{CS}$ , SCL, SDO, and SDI Serial Timing

# 2 or 3-Cell, Step-Up/Down, Two-Way Pager System IC

## Applications Information

### Component Selection

The MAX769 requires minimal design calculation and is optimized for the component values shown in Figure 2. However, some flexibility in component selection is still allowed, as described in the following text. A list of suitable components is provided in Table 6.

Inductor L1 is nominally 68μH, but values from 47μH to 100μH should be satisfactory. The inductor current rating should be 300mA or more if full output current (80mA) is needed. If less output current is required, the inductor current rating can be reduced proportionally but should never be less than 150mA.

Inductor resistance should be minimized for best efficiency, but since the MAX769 N-channel switch resistance is typically 0.9Ω, efficiency does not improve significantly for coil resistances below 0.4Ω.

Filter capacitors C1–C4 should be low-ESR types (tantalum or ceramic) for lowest ripple and best noise rejection. The values shown in Figure 2 are optimized for each output's rated current. Lower required output current allows smaller capacitance values.

Resistors at the LBI and RSIN inputs set the voltage at which the LBO and RSO outputs trigger. The voltage threshold for both LBI and RSI is 0.6V. The resistors required to set a desired trip voltage, (Figure 2) VTRIP, are calculated by:

$$R1 = R2[(V_{TRIP(LBO)} / 0.6) - 1]$$

$$R3 = R4[(V_{TRIP(LBO)} / 0.6) - 1]$$

To minimize battery drain, use large values for R2 and R4 (>100kΩ) in the above equations; 470kΩ is a good starting value.

See the *Low-Noise Analog Supply (REG2)* section for information on selecting ROFS.

Since LBO and RSO are open-drain outputs, pull-up resistors are usually required. Normally these will be pulled up to REG1. 100kΩ is recommended as a compromise between response time and current drain, although other values can be used. Since LBI and RSO are high (open circuit) during normal operation, current normally does not flow in the pull-up resistors until a low-battery or reset event occurs.

### Logic Levels

Note that since the MAX769's internal logic is powered from REG1, the input logic levels at the digital inputs (DR2IN, RUN, SYNC, CS, and SDI) as well as the logic output level of SDO are governed by the voltage at REG1. Logic-high inputs at these pins should not exceed VREG1. Digital inputs should either be driven

from external logic (or a μP) powered from REG1, or by open-drain logic devices that are pulled up to REG1.

### Board Layout and Noise Reduction

The MAX769 makes every effort in its internal design to minimize noise and EMI. Nevertheless, prudent layout practices are still suggested for best performance. Recommendations are as follows:

- 1) Keep trace lengths at L1, LX1, and LX2, as well as at PGND, as short and wide as possible. Since LX1 and LX2 toggle between VBATT and VOUT at a fast rate, minimizing the trace length serves to reduce excess PC board area that might act as an antenna.
- 2) Place the filter capacitors at OUT, REG1, REG2, and REG3 as close to their respective pins as possible (no more than 0.5mm away).
- 3) Consider using an inductor at L1. A shielded inductor at L1 will minimize radiated noise, but may not be essential. Toroids will also exhibit EMI performance similar to that of shielded coils.
- 4) Keep the power components at the uppermost part of the IC to minimize coupling to other parts of the circuit. The LX1, LX2, OUT, and PGND pins are located at the uppermost part of the IC to facilitate PC board layout. Other pins in this area are digital and are not affected by close proximity to switching nodes.
- 5) Use a separate short, wide ground trace for PGND and the ground side of the BATT and OUT filter capacitors. Tie this trace to the ground plane.

**Table 6. External Components**

SUPPLIER	PART NO.	COMMENTS
<b>INDUCTORS (68μH)</b>		
Coilcraft	DT1608C-223, DT1608C-683	0.58Ω, 3.18mm high, shielded
Murata	LQH4N680K	1.9Ω, 2.6mm high, low current, low cost
Sumida	CD54-680	0.46Ω, 4.5mm high
	CDR74B-680	0.33Ω, 4.5mm high, shielded
	CD73-680	0.33Ω, 3.5mm high
<b>CAPACITORS</b>		
AVX	TPS series	Tantalum
Marcon	THCR series	Ceramic
Sprague	595D series	Tantalum
TDK	C3216 series	Ceramic
<b>STORAGE CAPACITOR (optional at NICD pin)</b>		
Polystor	A-10300	1.5 Farads

# 2 or 3-Cell, Step-Up/Down, Two-Way Pager System IC

## Pin Configuration

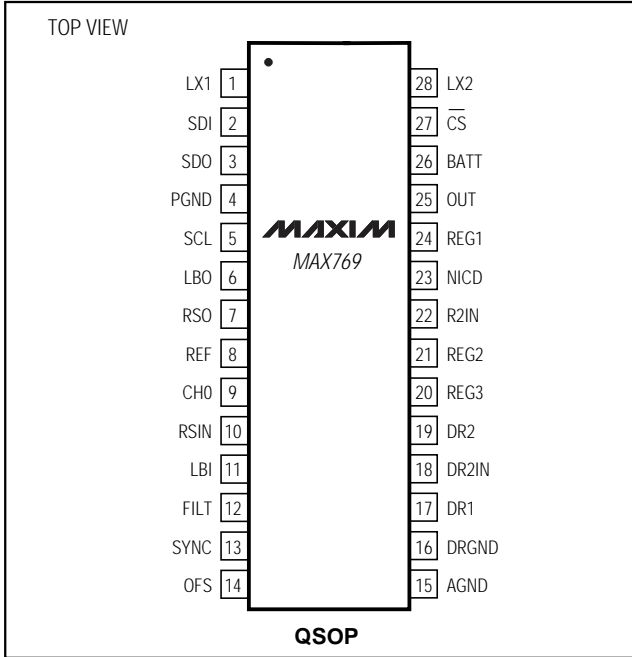

## Package Information

DIM	INCHES		MILLIMETERS		N
	MIN	MAX	MIN	MAX	
A	.061	.068	1.55	1.73	
A1	.004	.0098	0.102	0.249	
A2	.035	.061	1.40	1.55	
B	.008	.012	0.20	0.31	
C	.0075	.0098	0.191	0.249	
D	SEE VARIATIONS				
E	.150	.157	3.81	3.99	
e	.025	BSC	0.635	BSC	
H	.230	.244	5.84	6.20	
h	.010	.016	0.25	0.41	
L	.016	.035	0.41	0.89	
N	SEE VARIATIONS				
X	SEE VARIATIONS				
Y	.071	.087	1.803	2.209	
alpha	0°	8°	0°	8°	

VARIATIONS:

DIM	INCHES		MILLIMETERS		N
	MIN	MAX	MIN	MAX	
D	.189	.196	4.80	4.98	16AA
S	.0020	.0070	0.05	0.18	
X	.107	.123	2.72	3.12	
D	.337	.344	8.56	8.74	20AB
S	.0500	.0550	1.270	1.397	
D	.337	.344	8.56	8.74	24AC
S	.0250	.0300	0.635	0.762	
D	.386	.393	9.80	9.98	28AD
S	.0250	.0300	0.635	0.762	
X	.271	.287	6.88	7.29	

NOTES:

- D & E DO NOT INCLUDE MOLD FLASH OR PROTRUSIONS
- MOLD FLASH OR PROTRUSIONS NOT TO EXCEED .006" PER SIDE.
- HEAT SLUG DIMENSIONS X AND Y APPLY ONLY TO 16 AND 28 LEAD POWER-QSOB PACKAGES.
- CONTROLLING DIMENSIONS: INCHES.

MAXIM  
 PROPRIETARY INFORMATION  
 TITLE: PACKAGE OUTLINE, QSOB, .150", .025" LEAD PITCH  
 APPROVAL: \_\_\_\_\_ DOCUMENT CONTROL NO: 21-0055 REV: B 1/1



Компания «Океан Электроники» предлагает заключение долгосрочных отношений при поставках импортных электронных компонентов на взаимовыгодных условиях!

Наши преимущества:

- Поставка оригинальных импортных электронных компонентов напрямую с производств Америки, Европы и Азии, а так же с крупнейших складов мира;
- Широкая линейка поставок активных и пассивных импортных электронных компонентов (более 30 млн. наименований);
- Поставка сложных, дефицитных, либо снятых с производства позиций;
- Оперативные сроки поставки под заказ (от 5 рабочих дней);
- Экспресс доставка в любую точку России;
- Помощь Конструкторского Отдела и консультации квалифицированных инженеров;
- Техническая поддержка проекта, помощь в подборе аналогов, поставка прототипов;
- Поставка электронных компонентов под контролем ВП;
- Система менеджмента качества сертифицирована по Международному стандарту ISO 9001;
- При необходимости вся продукция военного и аэрокосмического назначения проходит испытания и сертификацию в лаборатории (по согласованию с заказчиком);
- Поставка специализированных компонентов военного и аэрокосмического уровня качества (Xilinx, Altera, Analog Devices, Intersil, Interpoint, Microsemi, Actel, Aeroflex, Peregrine, VPT, Syfer, Eurofarad, Texas Instruments, MS Kennedy, Miteq, Cobham, E2V, MA-COM, Hittite, Mini-Circuits, General Dynamics и др.);

Компания «Океан Электроники» является официальным дистрибьютором и эксклюзивным представителем в России одного из крупнейших производителей разъемов военного и аэрокосмического назначения «JONHON», а так же официальным дистрибьютором и эксклюзивным представителем в России производителя высокотехнологичных и надежных решений для передачи СВЧ сигналов «FORSTAR».



## JONHON

«JONHON» (основан в 1970 г.)

Разъемы специального, военного и аэрокосмического назначения:

(Применяются в военной, авиационной, аэрокосмической, морской, железнодорожной, горно- и нефтедобывающей отраслях промышленности)

«FORSTAR» (основан в 1998 г.)

ВЧ соединители, коаксиальные кабели, кабельные сборки и микроволновые компоненты:

(Применяются в телекоммуникациях гражданского и специального назначения, в средствах связи, РЛС, а так же военной, авиационной и аэрокосмической отраслях промышленности).



Телефон: 8 (812) 309-75-97 (многоканальный)

Факс: 8 (812) 320-03-32

Электронная почта: [ocean@oceanchips.ru](mailto:ocean@oceanchips.ru)

Web: <http://oceanchips.ru/>

Адрес: 198099, г. Санкт-Петербург, ул. Калинина, д. 2, корп. 4, лит. А