

## 50mA VOLTAGE REGULATOR (Wide Input Voltage Range)

NO.EA-153-111026

### OUTLINE

The R1515x series are CMOS-based positive voltage regulator (VR) ICs featuring 50mA output current. The R1515xxxxB has features of high input voltage and ultra-low supply current. A peak current limit circuit, a short current limit circuit, and a thermal shutdown circuit are built in the R1515x series.

The operating temperature is  $-40^{\circ}\text{C}$  to  $105^{\circ}\text{C}$  and the maximum input voltage is 36V, the R1515x series are very suitable for power source of car accessories.

The regulator output voltage is fixed in the R1515xxxxB and can be selected with a step of 0.1V in the range of 2.0V to 12.0V. Output voltage accuracy is  $\pm 2\%$ .

The packages for these ICs are the SOT-89-5 for space saving and the HSOP-6J for higher power applications.

### FEATURES

- Input Voltage ..... Max. 36V
- Supply Current ..... Typ.  $9\mu\text{A}$
- Standby Current ..... Typ.  $0.1\mu\text{A}$
- Temperature-Drift Coefficient of Output Voltage ... Typ.  $\pm 100\text{ppm}/^{\circ}\text{C}$
- Output Current ..... Min. 50mA ( $V_{\text{IN}}=V_{\text{OUT}}+3.0\text{V}$ ; R1515x050B)
- Line Regulation ..... Typ. 0.05%/V
- Output Voltage Accuracy.....  $\pm 2\%$
- Output Voltage Range..... 2.0V to 12.0V (0.1V steps)  
(For other voltages, please refer to MARK INFORMATION.)
- Packages ..... SOT-89-5, HSOP-6J
- Built-in Peak Current Limit Circuit
- Built-in Short Current Limit Circuit
- Built-in Thermal Shutdown Circuit
- Operating Temperature .....  $-40^{\circ}\text{C}$  to  $105^{\circ}\text{C}$

### APPLICATIONS

- Power source for home appliances such as refrigerators, rice cookers, electric water warmers, etc.
- Power source for car audio equipment, car navigation system, ETC system, etc.
- Power source for notebook PCs, digital TVs, cordless phones, and private LAN system, etc.
- Power source for office equipment machines such as copiers, printers, facsimiles, scanners, projectors, etc.
- Power source for the backup circuit for keyless entry system, etc.

## BLOCK DIAGRAMS

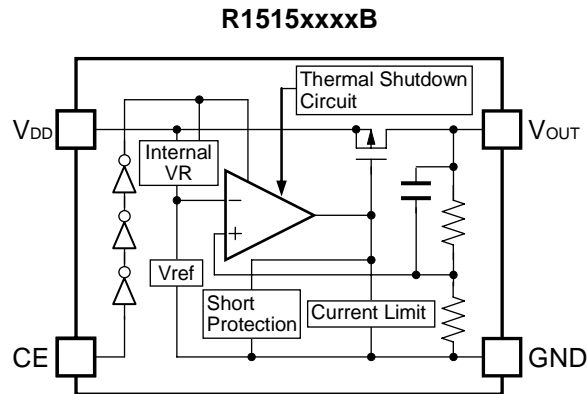

## SELECTION GUIDE

The output voltage, package for the ICs can be selected at the user's request.

Product Name	Package	Quantity per Reel	Pb Free	Halogen Free
R1515HxxxB-T1-FE	SOT-89-5	1,000 pcs	Yes	Yes
R1515SxxxB-E2-FE	HSOP-6J	1,000 pcs	Yes	Yes

xxx : The output voltage can be designated in the range of 2.0V(020) to 12.0V(120) in 0.1V steps.  
(For other voltages, please refer to MARK INFORMATION.)

## PIN CONFIGURATIONS



## PIN DESCRIPTIONS

### • SOT-89-5

Pin No.	Symbol	Description
1	$V_{OUT}$	Output Pin
2	GND*	Ground Pin
3	CE	Chip Enable Pin ("H" Active)
4	GND*	Ground Pin
5	$V_{DD}$	Input Pin

\*) The GND pin must be wired together when it is mounted on board.

### • HSOP-6J

Pin No.	Symbol	Description
1	$V_{OUT}$	Output Pin
2	GND*	Ground Pin
3	CE	Chip Enable Pin ("H" Active)
4	GND*	Ground Pin
5	GND*	Ground Pin
6	$V_{DD}$	Input Pin

\*) The GND pin must be wired together when it is mounted on board.

## ABSOLUTE MAXIMUM RATINGS

Symbol	Item	Rating	Unit
$V_{IN}$	Input Voltage	-0.3 to 50	V
$V_{IN}$	Peak Input Voltage *1	60	V
$V_{CE}$	Input Voltage (CE Pin)	-0.3 to $V_{IN}+0.3 \leq 50$	V
$V_{OUT}$	Output Voltage	-0.3 to $V_{IN}+0.3 \leq 50$	V
$I_{OUT}$	Output Current	150	mA
$P_D$	Power Dissipation (SOT-89-5) *2	900	mW
	Power Dissipation (HSOP-6J) *2	1700	
$T_{opt}$	Operating Temperature Range	-40 to 105	°C
$T_{stg}$	Storage Temperature Range	-55 to 125	°C

\*1) Duration time=200ms

\*2) For Power Dissipation, please refer to PACKAGE INFORMATION.

### ABSOLUTE MAXIMUM RATINGS

Electronic and mechanical stress momentarily exceeded absolute maximum ratings may cause the permanent damages and may degrade the life time and safety for both device and system using the device in the field.

The functional operation at or over these absolute maximum ratings is not assured.

### RECOMMENDED OPERATING CONDITIONS (ELECTRICAL CHARACTERISTICS)

All of electronic equipment should be designed that the mounted semiconductor devices operate within the recommended operating conditions. The semiconductor devices cannot operate normally over the recommended operating conditions, even if when they are used over such conditions by momentary electronic noise or surge. And the semiconductor devices may receive serious damage when they continue to operate over the recommended operating conditions.

## ELECTRICAL CHARACTERISTICS

### • R1515xxxxB

T<sub>opt</sub>=25°C

Symbol	Item	Conditions	Min.	Typ.	Max.	Unit
V <sub>IN</sub>	Input Voltage		4		36	V
I <sub>SS</sub>	Supply Current	V <sub>IN</sub> =V <sub>OUT</sub> +3.0V, I <sub>OUT</sub> =0mA		9	20	μA
I <sub>standby</sub>	Standby Current	V <sub>IN</sub> =36V, V <sub>CE</sub> =0V		0.1	1.0	μA
V <sub>OUT</sub>	Output Voltage	V <sub>IN</sub> =V <sub>OUT</sub> +3.0V, I <sub>OUT</sub> =1mA	×0.98		×1.02	V
I <sub>OUT</sub>	Output Current	V <sub>IN</sub> =V <sub>OUT</sub> +3.0V	50			mA
ΔV <sub>OUT</sub> /ΔI <sub>OUT</sub>	Load Regulation	V <sub>IN</sub> =V <sub>OUT</sub> +3.0V, 1mA ≤ I <sub>OUT</sub> ≤ 40mA	Refer to the following table			
ΔV <sub>OUT</sub> /ΔV <sub>IN</sub>	Line Regulation	V <sub>OUT</sub> +1.5V ≤ V <sub>IN</sub> ≤ 36V, I <sub>OUT</sub> =1mA		0.05	0.20	%/V
V <sub>DIF</sub>	Dropout Voltage	I <sub>OUT</sub> =20mA	Refer to the following table			
ΔV <sub>OUT</sub> /ΔT <sub>opt</sub>	Output Voltage Temperature Coefficient	V <sub>IN</sub> =V <sub>OUT</sub> +3.0V, I <sub>OUT</sub> =1mA −40°C ≤ T <sub>opt</sub> ≤ 105°C		±100		ppm /°C
I <sub>SC</sub>	Short Current Limit	V <sub>OUT</sub> =0V		50		mA
V <sub>CEH</sub>	CE Input Voltage "H"		1.5		V <sub>IN</sub>	V
V <sub>CEL</sub>	CE Input Voltage "L"		0		0.3	V
T <sub>TSD</sub>	Thermal Shutdown Temperature	Junction Temperature		150		°C
T <sub>TSR</sub>	Thermal Shutdown Released Temperature	Junction Temperature		125		°C

### • Load Regulation by Output Voltage

T<sub>opt</sub>=25°C

Output Voltage V <sub>OUT</sub> (V)	Load Regulation ΔV <sub>OUT</sub> /ΔI <sub>OUT</sub> (mV)		
	Conditions	Typ.	Max.
2.0 ≤ V <sub>OUT</sub> < 5.0	V <sub>IN</sub> =V <sub>OUT</sub> +3.0V	10	25
5.0 ≤ V <sub>OUT</sub> ≤ 12.0	1mA ≤ I <sub>OUT</sub> ≤ 40mA	20	35

### • Dropout Voltage by Output Voltage

T<sub>opt</sub>=25°C

Output Voltage V <sub>OUT</sub> (V)	Dropout Voltage V <sub>DIF</sub> (V)			
	Conditions	Typ.	Max.	
V <sub>OUT</sub> =2.0	I <sub>OUT</sub> =20mA		2.0	
V <sub>OUT</sub> =2.1			1.9	
V <sub>OUT</sub> =2.2			1.8	
V <sub>OUT</sub> =2.3			1.7	
V <sub>OUT</sub> =2.4			1.6	
V <sub>OUT</sub> =2.5			1.5	
V <sub>OUT</sub> =2.6			1.4	
V <sub>OUT</sub> =2.7			1.3	
V <sub>OUT</sub> =2.8			1.2	
V <sub>OUT</sub> =2.9			1.1	
V <sub>OUT</sub> =3.0			1.0	
V <sub>OUT</sub> =3.1			0.9	
V <sub>OUT</sub> =3.2			0.8	
V <sub>OUT</sub> =3.3			0.7	
V <sub>OUT</sub> =3.4			0.6	
V <sub>OUT</sub> =3.5			0.5	
V <sub>OUT</sub> =3.6			0.4	
3.7 ≤ V <sub>OUT</sub> < 4.0			0.35	0.60
4.0 ≤ V <sub>OUT</sub> < 5.0			0.25	0.40
5.0 ≤ V <sub>OUT</sub> ≤ 12.0			0.20	0.35

## TYPICAL APPLICATION

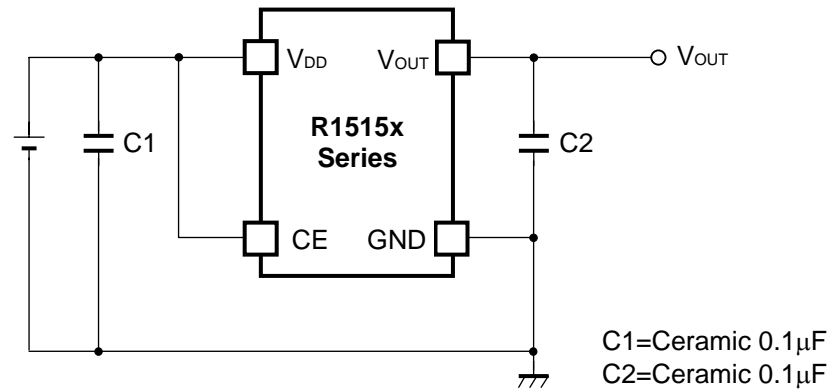

## TECHNICAL NOTES

When using these ICs, consider the following points:

### Phase Compensation

Phase Compensation of the R1515x Series has been made internally for stable operation even though the load current would vary. Therefore, without the capacitors, C1 and C2, the output voltage is regulated, however, for more stable operation, use capacitors as C1 and C2. Especially, if the input line is long and impedance is high, C1 is necessary. Moreover, if you use rather large C2, transient response will be improved. Recommended value is in the range from 0.1µF to 10µF. Wiring should be made as short as possible.

Connect the capacitor, C1 between V<sub>DD</sub> pin and GND pin and C2 between V<sub>OUT</sub> and GND as close as possible.

### GND wiring of mounting on board

No.2 pin and No.4 pin of SOT-89-5 package must be wired to the GND plane. No.2 pin, No.4 pin and No.5 pin of HSOP-6J package must be wired to the GND plane when it is mounted on board.

### Thermal Shutdown

Thermal shutdown function is included in the R1515x Series, if the junction temperature is equal or more than +150°C (Typ.), the operation of regulator would stop. After that, when the junction temperature is equal or less than +125°C (Typ.), the operation of regulator would restart. Unless the cause of rising temperature would remove, the regulator repeats on and off, and output waveform would be like consecutive pulses.

### Chip Enable Circuit

Do not make voltage level of chip enable pin keep floating level, or in between V<sub>CEH</sub> and V<sub>CEL</sub>. Otherwise, the output voltage would be unstable or indefinite, or unexpected current would flow internally.

## TEST CIRCUITS

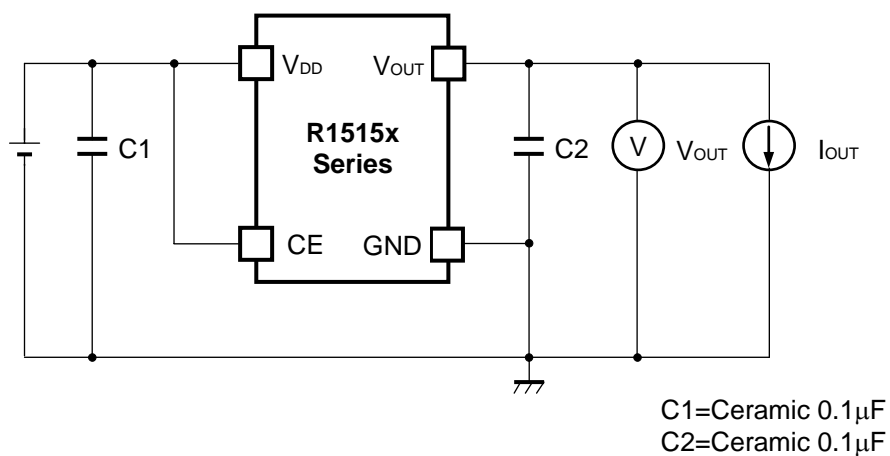

Basic Test Circuit

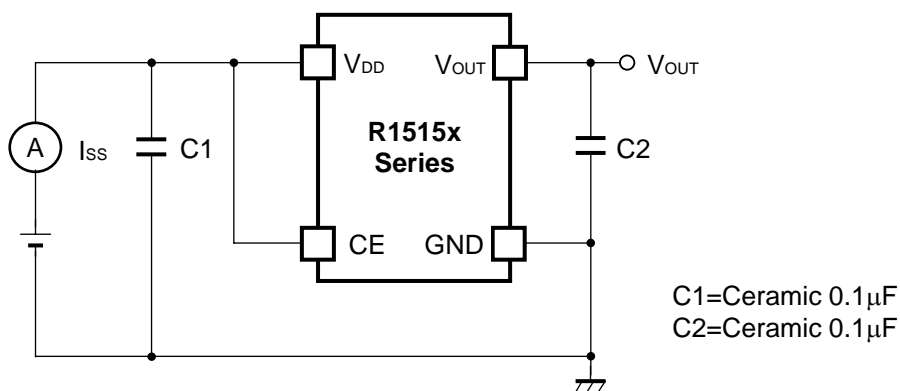

Test Circuit for Supply Current

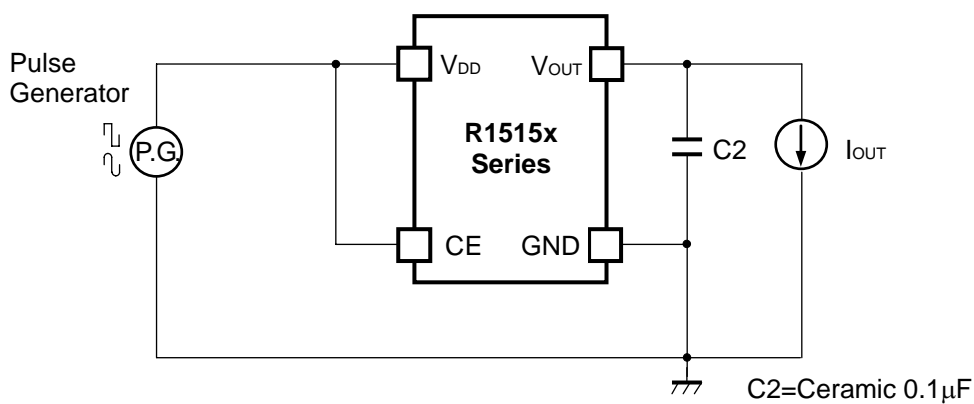

Test Circuit for Line Transient Response

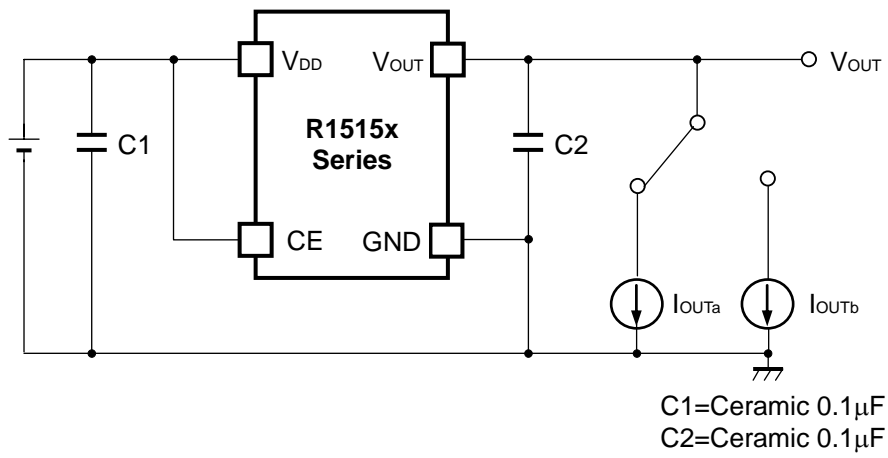

**Test Circuit for Load Transient Response**



## TYPICAL CHARACTERISTICS

### 1) Output Voltage vs. Output Current ( $T_{opt}=25^{\circ}C$ )

R1515x020B

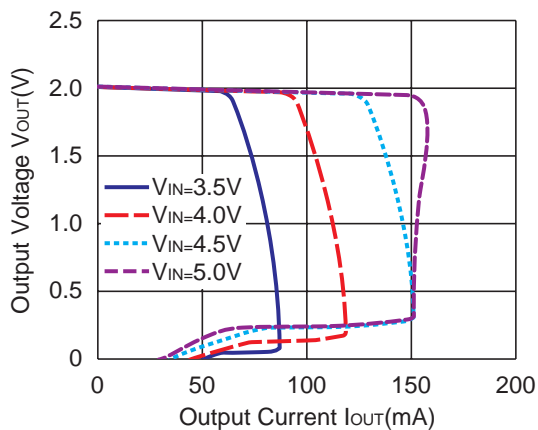

R1515x030B

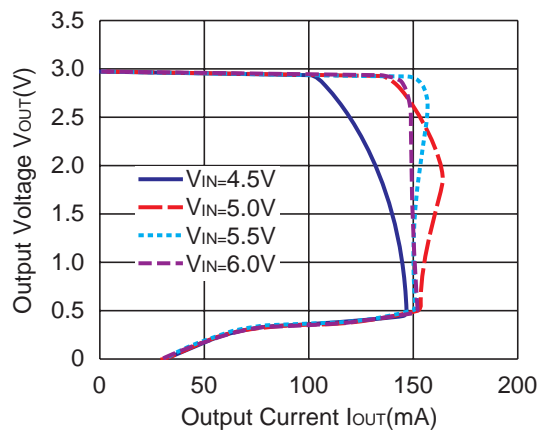

R1515x050B

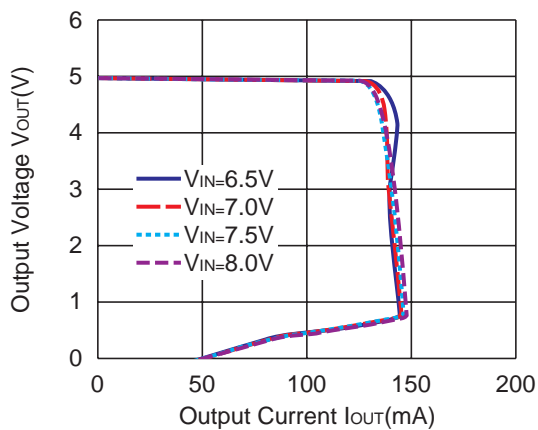

R1515x090B

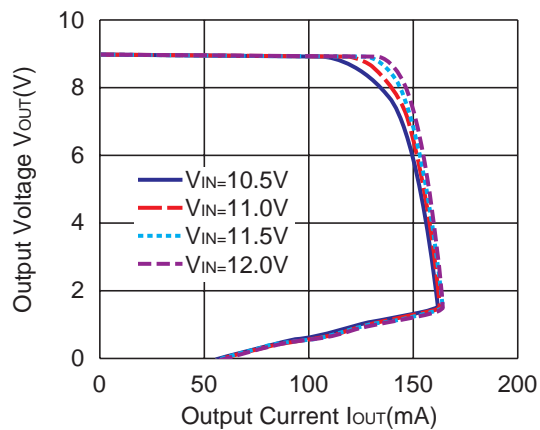

### 2) Output Voltage vs. Input Voltage ( $T_{opt}=25^{\circ}C$ )

R1515x020B

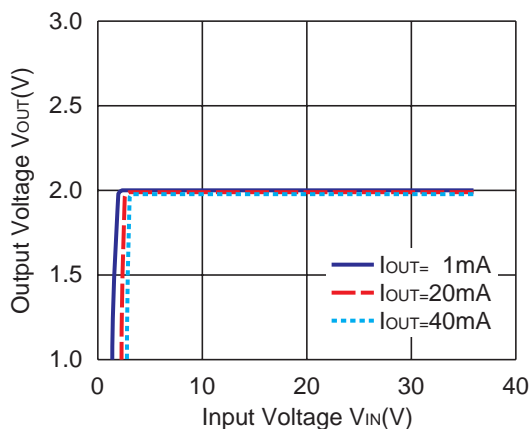

R1515x030B

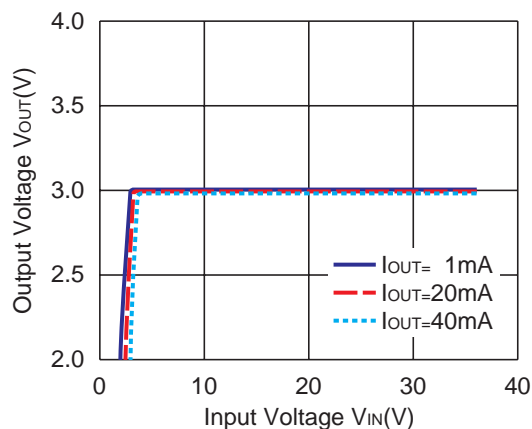

R1515x050B

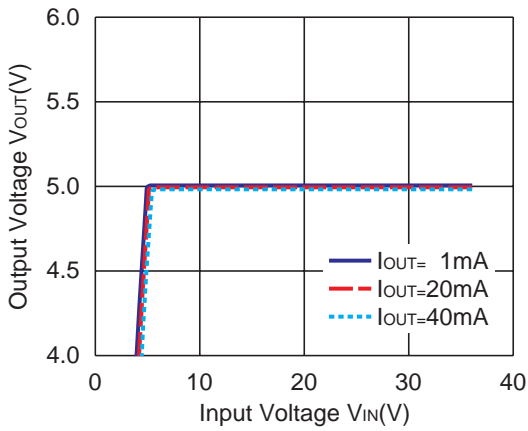

R1515x090B

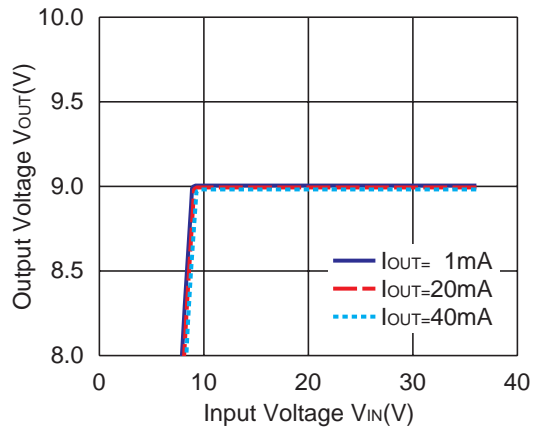

3) Dropout Voltage vs. Output Current

R1515x050B

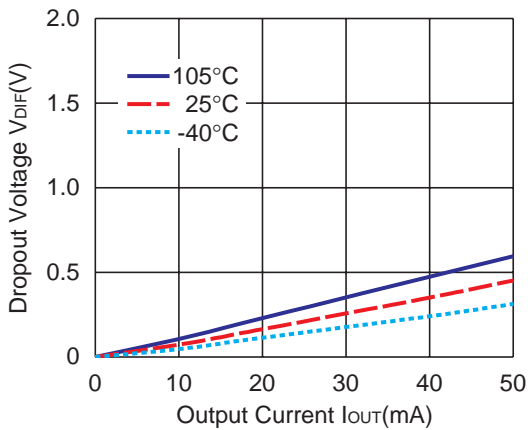

R1515x090B

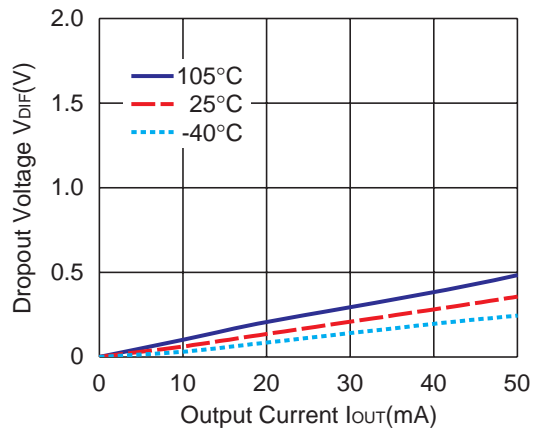

4) Output Voltage vs. Temperature

R1515x020B

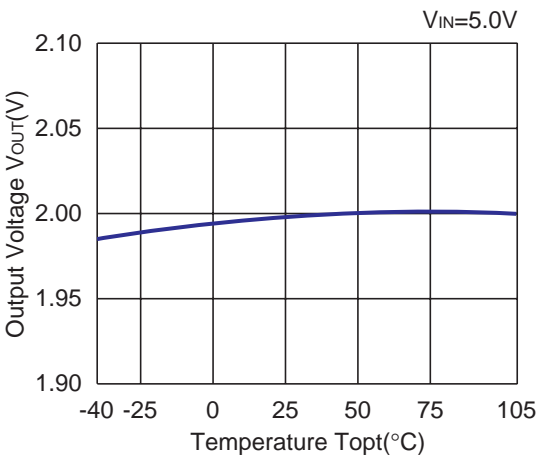

R1515x030B

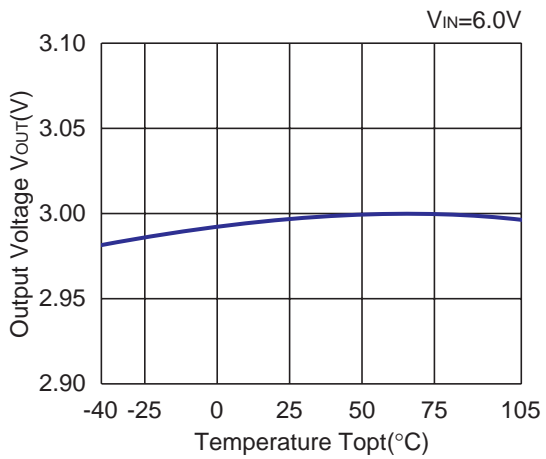

**R1515x050B**

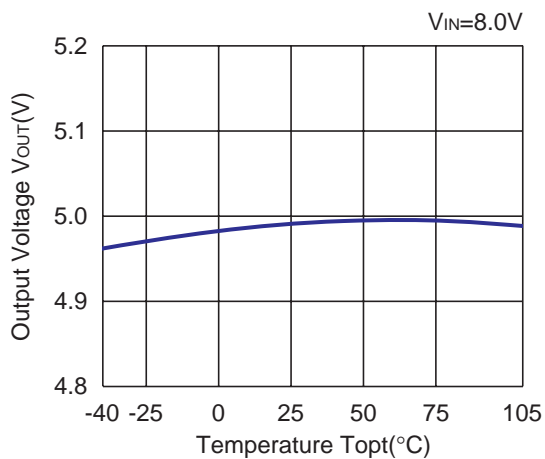

**R1515x090B**

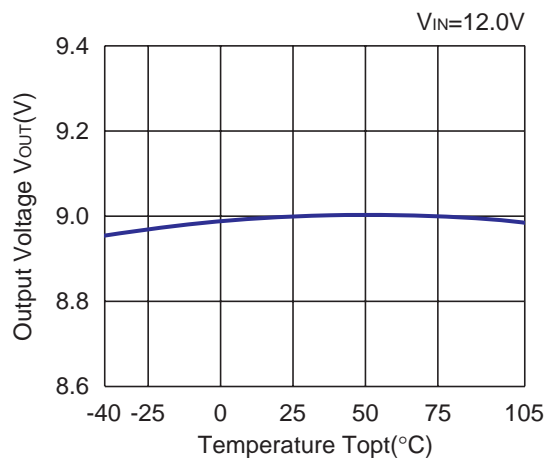

**5) Supply Current vs. Input Voltage ( $T_{opt}=25^{\circ}C$ )**

**R1515x020B**

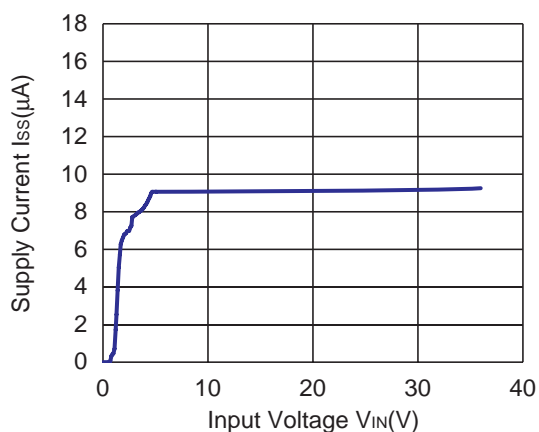

**R1515x030B**

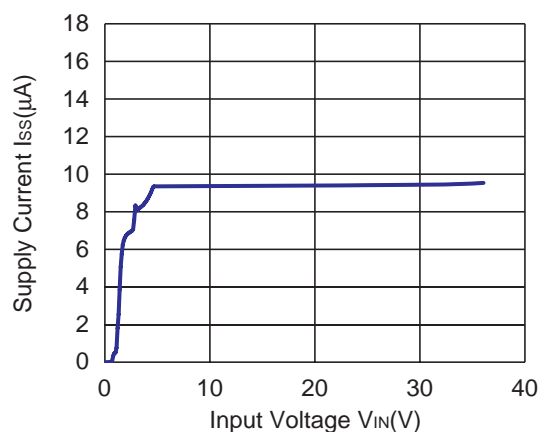

**R1515x050B**

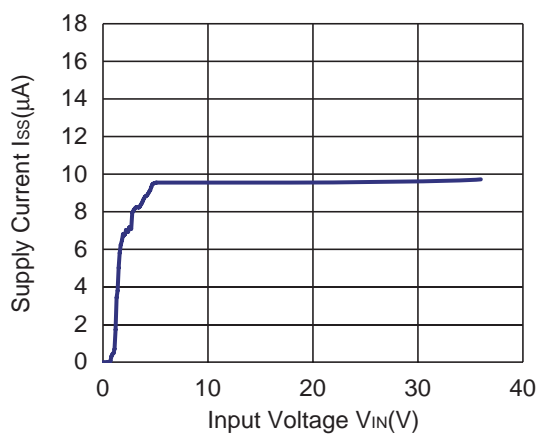

**R1515x090B**

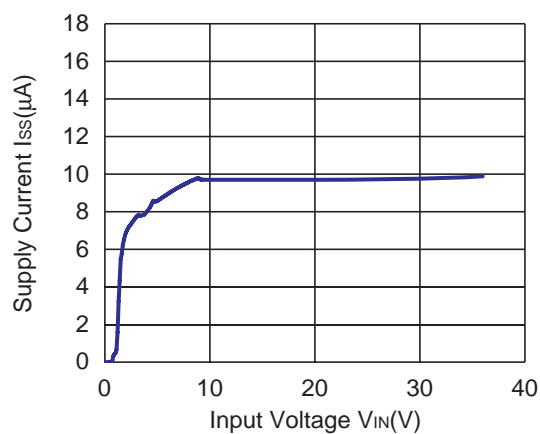

6) Supply Current vs. Temperature

R1515x020B

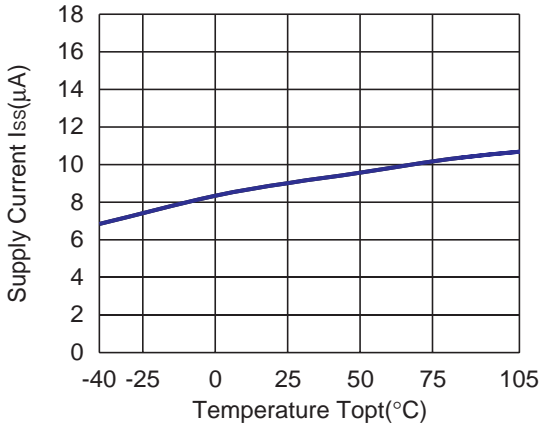

R1515x030B

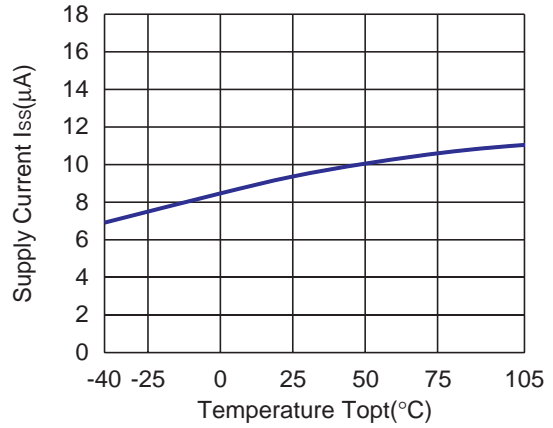

R1515x050B

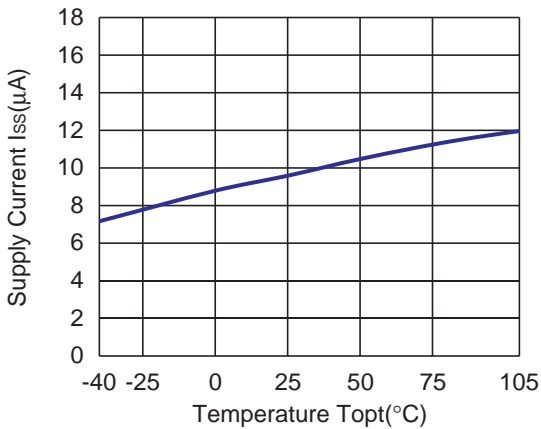

R1515x090B

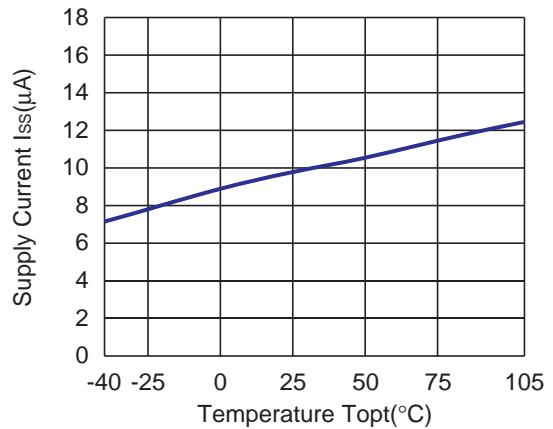

7) Input Transient Response (I<sub>OUT</sub>=1mA, t<sub>r</sub>=t<sub>f</sub>=50μs, C<sub>2</sub>=Ceramic 0.1μF, T<sub>opt</sub>=25°C)

R1515x020B

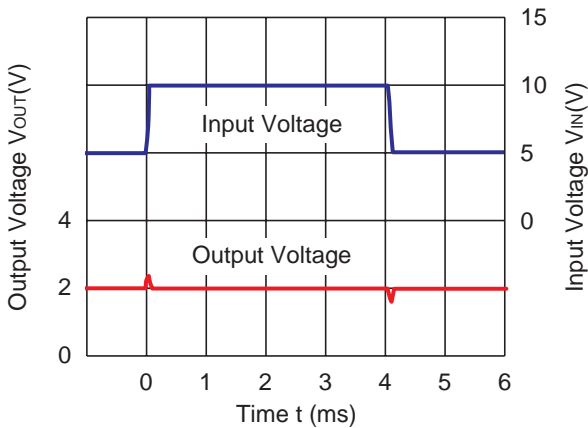

R1515x030B

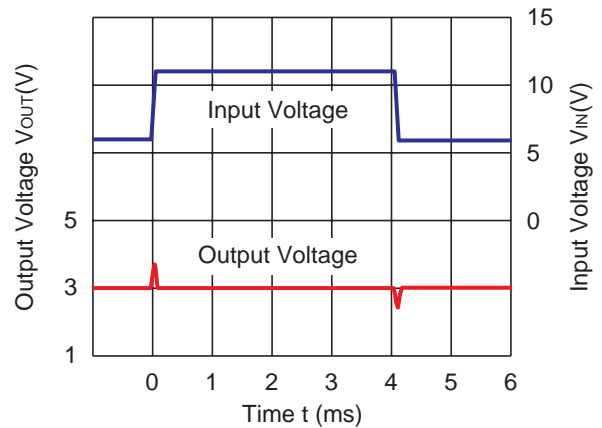

R1515x050B

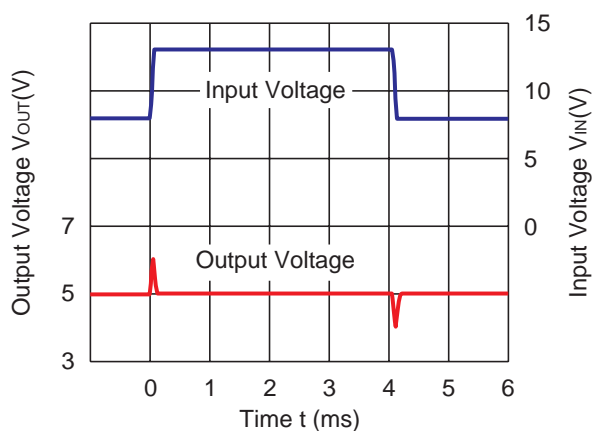

R1515x090B

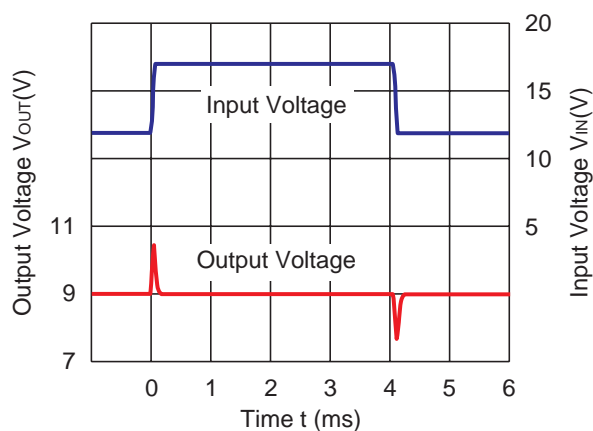

8) Load Transient Response (C2=Ceramic 0.1μF, T<sub>opt</sub>=25°C)

R1515x020B

V<sub>IN</sub>=5.0V  
tr=tf=50μs

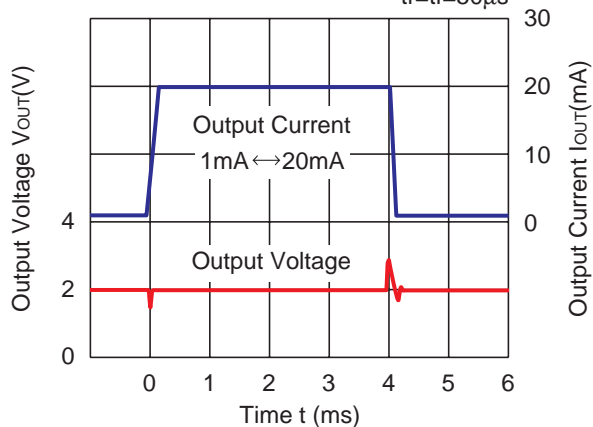

R1515x030B

V<sub>IN</sub>=6.0V  
tr=tf=50μs

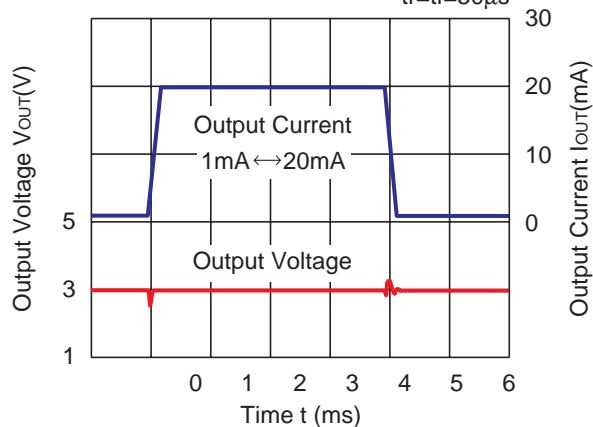

R1515x050B

V<sub>IN</sub>=8.0V  
tr=tf=50μs

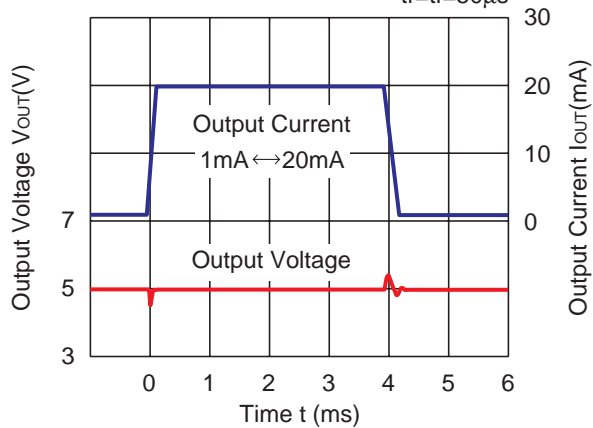

R1515x090B

V<sub>IN</sub>=12.0V  
tr=tf=50μs

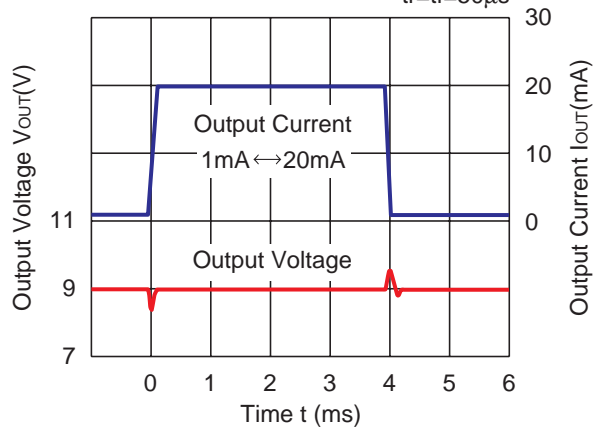



1. The products and the product specifications described in this document are subject to change or discontinuation of production without notice for reasons such as improvement. Therefore, before deciding to use the products, please refer to Ricoh sales representatives for the latest information thereon.
2. The materials in this document may not be copied or otherwise reproduced in whole or in part without prior written consent of Ricoh.
3. Please be sure to take any necessary formalities under relevant laws or regulations before exporting or otherwise taking out of your country the products or the technical information described herein.
4. The technical information described in this document shows typical characteristics of and example application circuits for the products. The release of such information is not to be construed as a warranty of or a grant of license under Ricoh's or any third party's intellectual property rights or any other rights.
5. The products listed in this document are intended and designed for use as general electronic components in standard applications (office equipment, telecommunication equipment, measuring instruments, consumer electronic products, amusement equipment etc.). Those customers intending to use a product in an application requiring extreme quality and reliability, for example, in a highly specific application where the failure or misoperation of the product could result in human injury or death (aircraft, spacevehicle, nuclear reactor control system, traffic control system, automotive and transportation equipment, combustion equipment, safety devices, life support system etc.) should first contact us.
6. We are making our continuous effort to improve the quality and reliability of our products, but semiconductor products are likely to fail with certain probability. In order to prevent any injury to persons or damages to property resulting from such failure, customers should be careful enough to incorporate safety measures in their design, such as redundancy feature, fire containment feature and fail-safe feature. We do not assume any liability or responsibility for any loss or damage arising from misuse or inappropriate use of the products.
7. Anti-radiation design is not implemented in the products described in this document.
8. Please contact Ricoh sales representatives should you have any questions or comments concerning the products or the technical information.



**Ricoh is committed to reducing the environmental loading materials in electrical devices with a view to contributing to the protection of human health and the environment.**

Ricoh has been providing RoHS compliant products since April 1, 2006 and Halogen-free products since April 1, 2012.

**RICOH** RICOH ELECTRONIC DEVICES CO., LTD.

<http://www.e-devices.ricoh.co.jp/en/>

#### Sales & Support Offices

##### **RICOH ELECTRONIC DEVICES CO., LTD.**

**Higashi-Shinagawa Office (International Sales)**  
3-32-3, Higashi-Shinagawa, Shinagawa-ku, Tokyo 140-8655, Japan  
Phone: +81-3-5479-2857 Fax: +81-3-5479-0502

##### **RICOH EUROPE (NETHERLANDS) B.V.**

**Semiconductor Support Centre**  
Prof. W.H. Keesomlaan 1, 1183 DJ Amstelveen, The Netherlands  
Phone: +31-20-5474-309

##### **RICOH ELECTRONIC DEVICES KOREA CO., LTD.**

3F, Haesung Bldg. 504, Teheran-ro, Gangnam-gu, Seoul, 135-725, Korea  
Phone: +82-2-2135-5700 Fax: +82-2-2051-5713

##### **RICOH ELECTRONIC DEVICES SHANGHAI CO., LTD.**

Room 403, No.2 Building, No.690 Bilbo Road, Pu Dong New District, Shanghai 201203, People's Republic of China  
Phone: +86-21-5027-3200 Fax: +86-21-5027-3299

##### **RICOH ELECTRONIC DEVICES CO., LTD.**

**Taipei office**  
Room 109, 10F-1, No.51, Hengyang Rd., Taipei City, Taiwan (R.O.C.)  
Phone: +886-2-2313-1621/1622 Fax: +886-2-2313-1623

# Mouser Electronics

Authorized Distributor

Click to View Pricing, Inventory, Delivery & Lifecycle Information:

[Ricoh Electronics:](#)

[R1515S030B-E2-FE](#)

Компания «Океан Электроники» предлагает заключение долгосрочных отношений при поставках импортных электронных компонентов на взаимовыгодных условиях!

Наши преимущества:

- Поставка оригинальных импортных электронных компонентов напрямую с производств Америки, Европы и Азии, а так же с крупнейших складов мира;
- Широкая линейка поставок активных и пассивных импортных электронных компонентов (более 30 млн. наименований);
- Поставка сложных, дефицитных, либо снятых с производства позиций;
- Оперативные сроки поставки под заказ (от 5 рабочих дней);
- Экспресс доставка в любую точку России;
- Помощь Конструкторского Отдела и консультации квалифицированных инженеров;
- Техническая поддержка проекта, помощь в подборе аналогов, поставка прототипов;
- Поставка электронных компонентов под контролем ВП;
- Система менеджмента качества сертифицирована по Международному стандарту ISO 9001;
- При необходимости вся продукция военного и аэрокосмического назначения проходит испытания и сертификацию в лаборатории (по согласованию с заказчиком);
- Поставка специализированных компонентов военного и аэрокосмического уровня качества (Xilinx, Altera, Analog Devices, Intersil, Interpoint, Microsemi, Actel, Aeroflex, Peregrine, VPT, Syfer, Eurofarad, Texas Instruments, MS Kennedy, Miteq, Cobham, E2V, MA-COM, Hittite, Mini-Circuits, General Dynamics и др.);

Компания «Океан Электроники» является официальным дистрибьютором и эксклюзивным представителем в России одного из крупнейших производителей разъемов военного и аэрокосмического назначения «JONHON», а так же официальным дистрибьютором и эксклюзивным представителем в России производителя высокотехнологичных и надежных решений для передачи СВЧ сигналов «FORSTAR».



## JONHON

«JONHON» (основан в 1970 г.)

Разъемы специального, военного и аэрокосмического назначения:

(Применяются в военной, авиационной, аэрокосмической, морской, железнодорожной, горно- и нефтедобывающей отраслях промышленности)

«FORSTAR» (основан в 1998 г.)

ВЧ соединители, коаксиальные кабели, кабельные сборки и микроволновые компоненты:

(Применяются в телекоммуникациях гражданского и специального назначения, в средствах связи, РЛС, а так же военной, авиационной и аэрокосмической отраслях промышленности).



Телефон: 8 (812) 309-75-97 (многоканальный)

Факс: 8 (812) 320-03-32

Электронная почта: [ocean@oceanchips.ru](mailto:ocean@oceanchips.ru)

Web: <http://oceanchips.ru/>

Адрес: 198099, г. Санкт-Петербург, ул. Калинина, д. 2, корп. 4, лит. А