



USB Host Charger Identification Analog Switches

General Description

The SLG55596 is a USB device that combines high speed USB switches with a USB host charger (dedicated charger) identification circuit. The device supports both the latest USB Battery Charging Specification Revision 1.2 including data contact detection and a set resistor bias for Apple* compliant devices as well as legacy USB D+/D- short detection using data line pull-up.

The SLG55596 can also support CDP mode (FAST charging and data communication available mode if smartphone can support CDP mode).

The SLG55596 can also support low speed / full speed mouse/keyboard wake-up from S3 mode.

Features

- High Speed USB Switching
- Low 4.0pF (typ) On Capacitance
- Low 4.0Ω (typ) On Resistance
- Low 0.5Ω (typ) On Resistance Flatness
- 4.5V to 5.5V Supply Range
- Low Supply Current
- Automatic Current-Limit Switch Control
- Automatic USB Charger Identification Circuit
- CDP Support (active USB 2.0 data communication with 1.5A charging)
- Apple iPad* @ 2.4A charging current support
- Automatic CDP/SDP mode support with SMART-CDP=1 for "Always Data Communication"
- Chinese Telecom Standard YD/T 1591-2009 specification support
- Samsung Galaxy Tab** charge scheme support
- Pb-Free / RoHS Compliant / Halogen-Free
- TDFN-8 Package

Pin Configuration - SLG55596

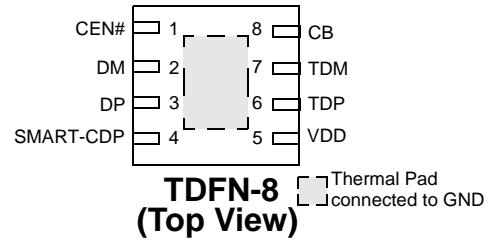

* Apple iPhone, iPad and iPod are trademarks of Apple Inc., registered in the U.S. and other countries.

** Samsung Galaxy Tab are trademarks of Samsung Electronics, registered in Korea and other countries.

Block Diagram

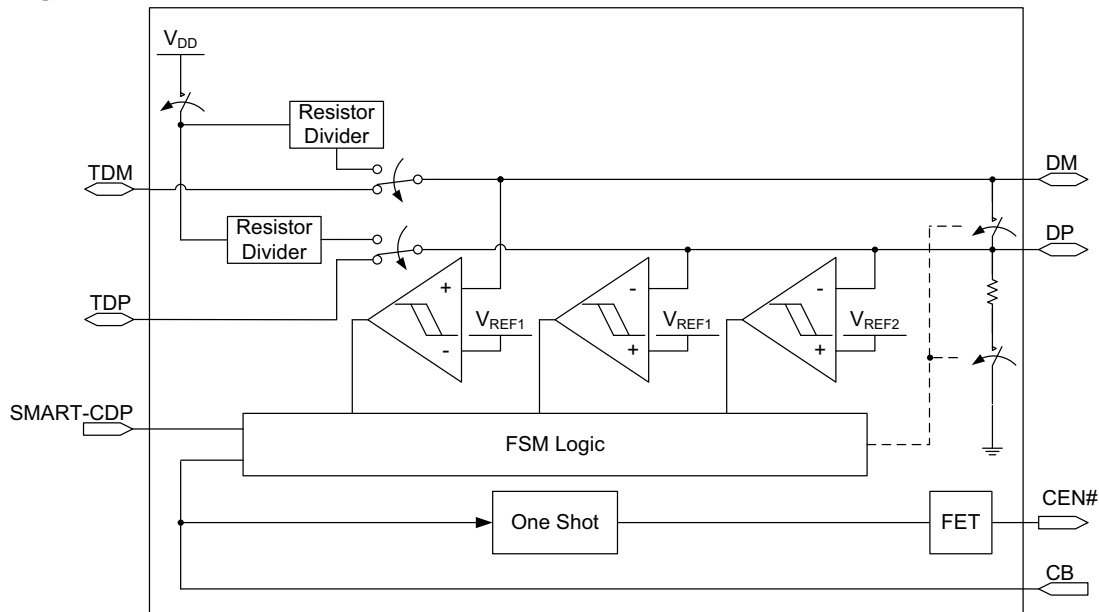



Pin Description - SLG55596

Pin #	Pin Name	Type	Pin Description
1	CEN#	Output	P-FET Open Drain Output. Current Limit Switch (CLS) Control Output. CB changes from 0 to 1 or 1 to 0. CEN# will be high for 2 seconds (typ)
2	DM	Input/Output	USB Connector D-
3	DP	Input/Output	USB Connector D+
4	SMART-CDP	Input	Input Control logic (see truth table)
5	VDD	PWR	Power Supply. Connect a 0.1 μ F capacitor between VDD and GND as close as possible to the device.
6	TDP	Input/Output	Host USB Transceiver D+ Connection
7	TDM	Input/Output	Host USB Transceiver D- Connection
8	CB	Input	Switch Control Bit 0 = autodetection charger identification active 1 = charging downstream port with active USB2.0 data communication mode with 1.5A support
9	Thermal Pad	GND	Ground

Truth Table

CB	SMART-CDP	Function
0	0 or 1	DCP autodetect with mouse/keyboard wakeup (Pin 4 = 0 or 1)
1	0	S0 charging with SDP only
1	1	S0 charging with CDP or SDP only (depending on external device) And, when Non-CDP phone is plugged in, the CDP mode will be changed automatically to SDP mode during handshaking protocol for supporting data communication.

Ordering Information

Part Number	Type
SLG55596V	TDFN-8
SLG55596VTR	TDFN-8 - Tape and Reel



Absolute Maximum Ratings

Parameter	Min.	Max.	Unit
Supply Voltage	-0.3	6.0	V
Continuous Current into any terminal	-30	+30	mA
Continuous Power Dissipation	--	954	mW
Operating Temperature Range	-40	85	°C
Junction Temperature		150	°C
Storage Temperature Range	-65	150	°C
Lead Temperature (Soldering, 10s)		260	°C

Note: Stresses greater than those listed under "Absolute Maximum Ratings" may cause permanent damage to the device. This is a stress rating only and functional operation of the device at these or any other conditions above those indicated in the operational sections of this specification is not implied. Exposure to absolute maximum rating conditions for extended periods may affect reliability.

Electrical Characteristics - Power Supply

V_{DD} = 4.5V to 5.5V, T_A = 25°C (unless specified otherwise)

Parameter	Description	Condition/Note	Min.	Typ.	Max.	Unit
V _{DD}	Power Supply Range	V _{CB} > V _{IH}	4.5	5.0	5.5	V
		V _{CB} = 0V	4.75	--	5.25	V
I _{DD}	Supply Current V _{DD} = 5V	CB = LOW, SMART-CDP = X (autodetect with wakeup)	--	140	160	μA
		CB = HIGH, SMART-CDP = LOW (SDP)	--	20	30	μA
		CB = HIGH, SMART-CDP = HIGH (CDP)	--	30	50	μA

Electrical Characteristics - Analog Switch

V_{DD} = 4.5V to 5.5V, T_A = 25°C (unless specified otherwise)

Parameter	Description	Condition/Note	Min.	Typ.	Max.	Unit
V _{DP} , V _{DM}	Analog signal Range		0	--	V _{DD}	V
R _{ON}	On Resistance TDP/TDM Switch	V _{DD} = -0.4V to 0.4V, I = 10mA	--	3.5	--	Ω
		V _{DP} = V _{DM} = 0V to 3.3V V _{DD} = 5V	--	4.0	7	Ω
ΔR _{ON}	On Resistance Match between channels TDP/TDM Switch	V _{DD} = 5.0V V _{DP} = V _{DM} = 400mV I _{DP} = I _{DM} = 10mA	--	0.1	--	Ω
R _{FLAT}	On Resistance flatness TDP/TDM Switch	V _{DD} = 5.0V V _{DP} = V _{DM} = 0V to V _{DD} I _{DP} = I _{DM} = 10mA	--	0.5	--	Ω
R _{SHORT}	On Resistance of TDP/TDM Short	V _{CB} = 0V V _{DP} = 1V I _{DP} = I _{DM} = 10mA	--	50	70	Ω
I _{TDPOFF} , I _{TDMOFF}	Off-Leakage Current	V _{DD} = 3.6V V _{DP} = V _{DM} = 0.3V to 3.3V V _{TDP} = V _{TDM} = 3.3V to 0.3V V _{CB} = 0V	-250	--	250	nA
I _{DPON} , I _{DMON}	Off-Leakage Current	V _{DD} = 3.6V V _{DP} = V _{DM} = 3.3V to 0.3V V _{CB} = V _{DD}	-250	--	250	nA



Electrical Characteristics - Dynamic Performance

$V_{DD} = 4.5V$ to $5.5V$, $T_A = 25^\circ C$ (unless specified otherwise)

Parameter	Description	Condition/Note	Min.	Typ.	Max.	Unit
T_{ON}	Turn On Time	V_{TDP} or $V_{TDM} = 1.5V$ $R_L = 300\Omega$ $C_L = 35pF$	--'	20	100	μs
T_{OFF}	Turn Off Time	V_{TDP} or $V_{TDM} = 1.5V$ $R_L = 300\Omega$ $C_L = 35pF$	--'	1	5	μs
T_{PLH}, T_{PHL}	TDP/TDM Switch Propagation Delay	$R_L = R_S = 50\Omega$	--	60	--	ps
T_{SKEW}	Output Skew	Skew between DP and DM when connected to TDP and TDM $R_L = R_S = 50\Omega$	--	40	--	ps
C_{OFF}	TDP/TDM Off-Capacitance	$f = 1MHz$	--'	2.0	--	pF
C_{ON}	DP/DM On-Capacitance	$f = 240MHz$	--'	4.0	5.5	pF
BW	-3dB Bandwidth	$R_L = R_S = 50\Omega$	--	1000	--	MHz
V_{ISO}	Off-Isolation	$V_{TDP}, V_{DP} = 0dBm$ $R_L = R_S = 50\Omega$ $f = 250MHz$	--	-20	--	dB
V_{CT}	Crosstalk	$V_{TDP}, V_{DP} = 0dBm$ $R_L = R_S = 50\Omega$ $f = 250MHz$	--	-25	--	dB

Electrical Characteristics - Internal Resistors

$V_{DD} = 4.5V$ to $5.5V$, $T_A = 25^\circ C$ (unless specified otherwise)

Parameter	Description	Condition/Note	Min.	Typ.	Max.	Unit
R_{PD}	DP/DM Short Pull-down		350	500	700	$k\Omega$
RT_{RP}	RP1/RP2 Ratio		0.8544	0.863	0.872	Ratio
R_{RP}	RP1 + RP2 Resistance		69.75	93.0	115.18	$k\Omega$
RT_{RM}	RM1/RM2 Ratio		0.8544	0.863	0.872	Ratio
R_{RM}	RM1 + RM2 Resistance		69.75	93.0	115.18	$k\Omega$

Electrical Characteristics - Logic Input CB

$V_{DD} = 4.5V$ to $5.5V$, $T_A = 25^\circ C$ (unless specified otherwise)

Parameter	Description	Condition/Note	Min.	Typ.	Max.	Unit
V_{IH}	CB Input Logic High		1.4	--	--	V
V_{IL}	CB Input Logic Low		--	--	0.4	V
I_{IN}	CB Input Leakage Current	$V_{DD} = 5.5V$ $0 \leq V_{CB} \leq V_{IL}$ or $V_{IH} \leq V_{CB} \leq V_{DD}$	-1	--	1	μA



Electrical Characteristics - Logic Input SMART-CDP

$V_{DD} = 4.5V$ to $5.5V$, $T_A = 25^\circ C$ (unless specified otherwise)

Parameter	Description	Condition/Note	Min.	Typ.	Max.	Unit
V_{IH}	SMART-CDP input Logic High		3.0	--	--	V
V_{IL}	SMART-CDP input Logic Low		--	--	0.8	V
I_{IN}	SMART-CDP Input Leakage Current	$V_{DD} = 5.5V$ $0V < V_{SMART-CDP} < V_{IL}$ or $V_{IH} < V_{SMART-CDP} < V_{DD}$	-1	--	1	μA

Electrical Characteristics - CEN# Outputs

$V_{DD} = 4.5V$ to $5.5V$, $T_A = 25^\circ C$ (unless specified otherwise)

Parameter	Description	Condition/Note	Min.	Typ.	Max.	Unit
T_{VBT}	V_{BUS} Toggle Time	CB = Logic 0 to Logic 1 or Logic 1 to Logic 0	1.5	2.0	2.5	s
$V_{OH_CEN\#}$	CEN# Output Logic High Voltage	CB = Logic 0 to Logic 1 $I_{SOURCE} = 2mA$	$V_{DD}-0.4V$	--	--	V
$I_{OUT_CEN\#}$	CEN# Output Leakage Current	$V_{DD} = 5.5V$ $V_{CEN\#} = 0V$ or CEN# deasserted	--	--	1	μA

Electrical Characteristics - ESD Protection

$V_{DD} = 4.5V$ to $5.5V$, $T_A = 25^\circ C$ (unless specified otherwise)

Parameter	Description	Condition/Note	Min.	Typ.	Max.	Unit
V_{ESD}	ESD Protection Level (DP and DM Only)	Human Body Model	--	± 8	--	kV
V_{ESD}	ESD Protection Level (All other pins)	Human Body Model	--	± 2	--	kV



CEN# Function Waveform

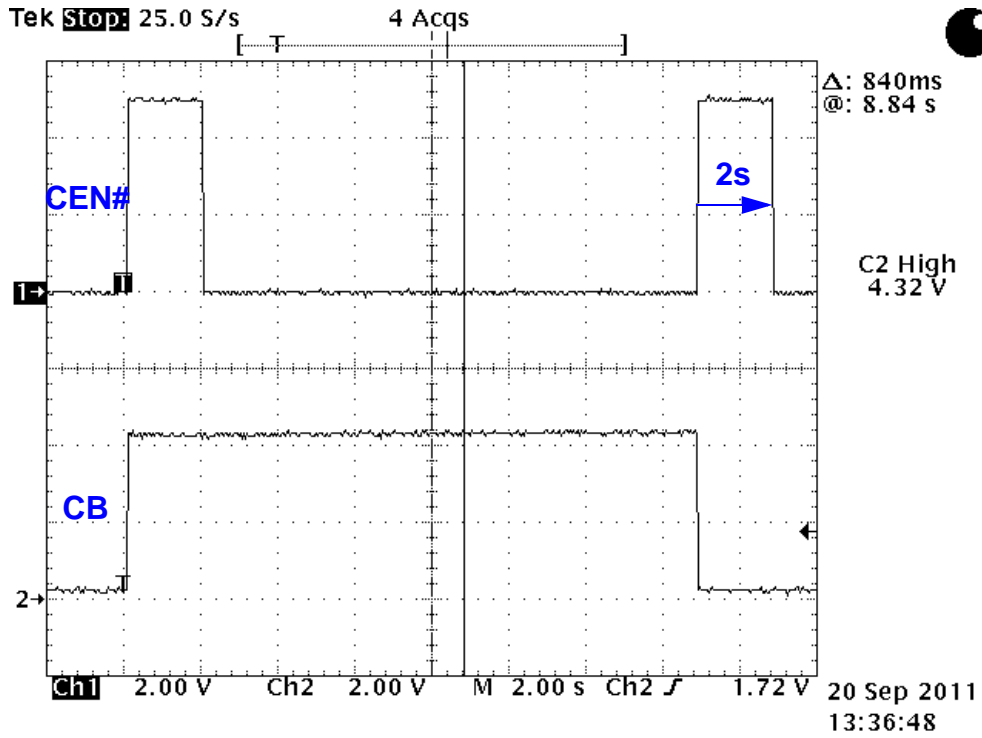



Package Top Marking System Definition



- XX – Part ID Field: identifies the specific device configuration
- A – Assembly Code Field: Assembly Location of the device.
- DD – Date Code Field: Coded date of manufacture
- L – Lot Code: Designates Lot #
- R – Revision Code: Device Revision



Package Drawing and Dimensions

8 Lead TDFN Package
JEDEC MO-229, Variation WCCD IC Net Weight: 0.0095

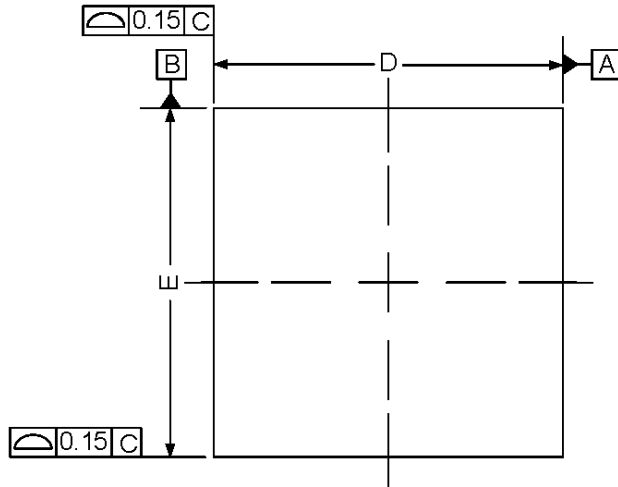

Symbol	Min (mm)	NOM (mm)	Max (mm)
A	0.70	0.75	0.80
A1	0.00	--	0.05
A2	--	0.55	--
A3	--	0.20	--
b	0.20	0.25	0.30
D	1.90	2.00	2.10
D2	1.50	1.60	1.70
E	1.90	2.00	2.10
E2	0.80	0.90	1.00
e	0.50 BSC		
L	0.20	0.30	0.40

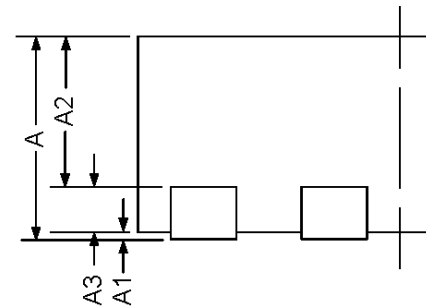
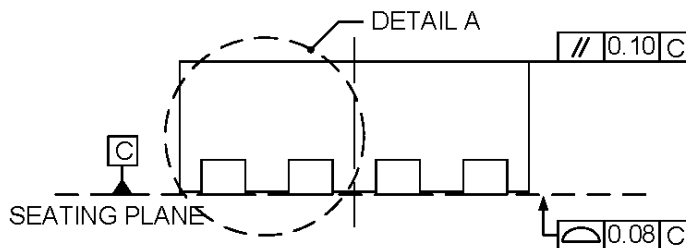

DETAIL A

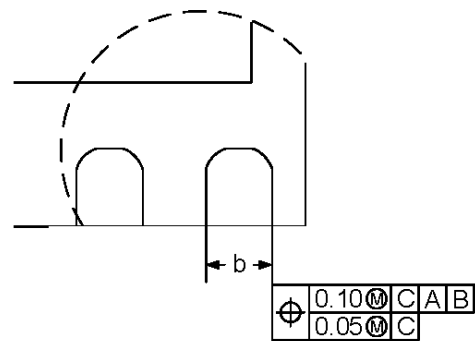
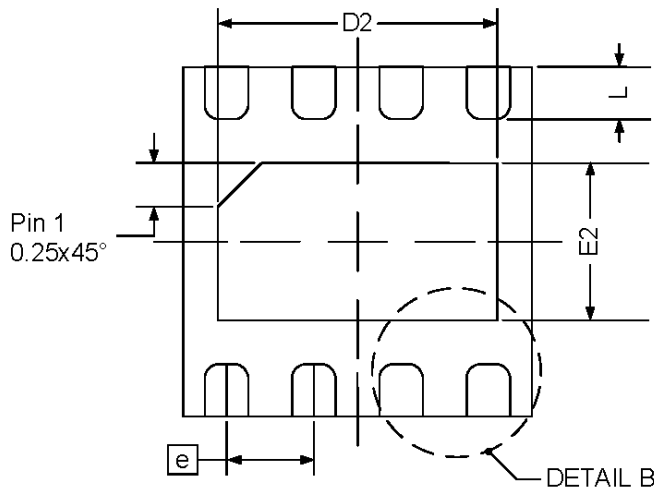

DETAIL B



Tape and Reel Specifications

Package Type	# of Pins	Nominal Package Size [mm]	Max Units		Reel & Hub Size [mm]	Leader (min)		Trailer (min)		Tape Width [mm]	Part Pitch [mm]
			per Reel	per Box		Pockets	Length [mm]	Pockets	Length [mm]		
TDFN 8L Green	8	2 x 2 x 0.75	3,000	3,000	178 / 60	100	400	100	400	8	4

Carrier Tape Drawing and Dimensions

Package Type	Pocket BTM Length	Pocket BTM Width	Pocket Depth	Index Hole Pitch	Pocket Pitch	Index Hole Diameter	Index Hole to Tape Edge	Index Hole to Pocket Center	Tape Width
	A0	B0	K0	P0	P1	D0	E	F	W
TDFN 8L Green	2.3	2.3	1.05	4	4	1.55	1.75	3.5	8



Refer to EIA-481 specification

Recommended Reflow Soldering Profile

Please see IPC/JEDEC J-STD-020: latest revision for reflow profile based on package volume of 3.00 mm³ (nominal). More information can be found at www.jedec.org.



Silego Website & Support

Silego Technology Website

Silego Technology provides online support via our website at <http://www.silego.com/>. This website is used as a means to make files and information easily available to customers.

For more information regarding Silego Green products, please visit:

<http://greenpak.silego.com/>
<http://greenfet.silego.com/>
<http://greenpak2.silego.com/>
<http://greenfet2.silego.com/>
<http://greenclk.silego.com/>

Products are also available for purchase directly from Silego at the Silego Online Store at <http://store.silego.com/>.

Silego Technical Support

Datasheets and errata, application notes and example designs, user guides, and hardware support documents and the latest software releases are available at the Silego website or can be requested directly at info@silego.com.

For specific GreenPAK design or applications questions and support please send e-mail requests to GreenPAK@silego.com

Users of Silego products can receive assistance through several channels:

Online Live Support

Silego Technology has live video technical assistance and sales support available at <http://www.silego.com/>. Please ask our live web receptionist to schedule a 1 on 1 training session with one of our application engineers.

Contact Your Local Sales Representative

Customers can contact their local sales representative or field application engineer (FAE) for support. Local sales offices are also available to help customers. More information regarding your local representative is available at the Silego website or send a request to info@silego.com

Contact Silego Directly

Silego can be contacted directly via e-mail at info@silego.com or user submission form, located at the following URL:

<http://support.silego.com/>

Other Information

The latest Silego Technology press releases, listing of seminars and events, listings of world wide Silego Technology offices and representatives are all available at <http://www.silego.com/>

THIS PRODUCT HAS BEEN DESIGNED AND QUALIFIED FOR THE CONSUMER MARKET. APPLICATIONS OR USES AS CRITICAL COMPONENTS IN LIFE SUPPORT DEVICES OR SYSTEMS ARE NOT AUTHORIZED. SILEGO TECHNOLOGY DOES NOT ASSUME ANY LIABILITY ARISING OUT OF SUCH APPLICATIONS OR USES OF ITS PRODUCTS. SILEGO TECHNOLOGY RESERVES THE RIGHT TO IMPROVE PRODUCT DESIGN, FUNCTIONS AND RELIABILITY WITHOUT NOTICE.

Компания «Океан Электроники» предлагает заключение долгосрочных отношений при поставках импортных электронных компонентов на взаимовыгодных условиях!

Наши преимущества:

- Поставка оригинальных импортных электронных компонентов напрямую с производств Америки, Европы и Азии, а так же с крупнейших складов мира;
- Широкая линейка поставок активных и пассивных импортных электронных компонентов (более 30 млн. наименований);
- Поставка сложных, дефицитных, либо снятых с производства позиций;
- Оперативные сроки поставки под заказ (от 5 рабочих дней);
- Экспресс доставка в любую точку России;
- Помощь Конструкторского Отдела и консультации квалифицированных инженеров;
- Техническая поддержка проекта, помощь в подборе аналогов, поставка прототипов;
- Поставка электронных компонентов под контролем ВП;
- Система менеджмента качества сертифицирована по Международному стандарту ISO 9001;
- При необходимости вся продукция военного и аэрокосмического назначения проходит испытания и сертификацию в лаборатории (по согласованию с заказчиком);
- Поставка специализированных компонентов военного и аэрокосмического уровня качества (Xilinx, Altera, Analog Devices, Intersil, Interpoint, Microsemi, Actel, Aeroflex, Peregrine, VPT, Syfer, Eurofarad, Texas Instruments, MS Kennedy, Miteq, Cobham, E2V, MA-COM, Hittite, Mini-Circuits, General Dynamics и др.);

Компания «Океан Электроники» является официальным дистрибьютором и эксклюзивным представителем в России одного из крупнейших производителей разъемов военного и аэрокосмического назначения «JONHON», а так же официальным дистрибьютором и эксклюзивным представителем в России производителя высокотехнологичных и надежных решений для передачи СВЧ сигналов «FORSTAR».



JONHON

«JONHON» (основан в 1970 г.)

Разъемы специального, военного и аэрокосмического назначения:

(Применяются в военной, авиационной, аэрокосмической, морской, железнодорожной, горно- и нефтедобывающей отраслях промышленности)

«FORSTAR» (основан в 1998 г.)

ВЧ соединители, коаксиальные кабели, кабельные сборки и микроволновые компоненты:

(Применяются в телекоммуникациях гражданского и специального назначения, в средствах связи, РЛС, а так же военной, авиационной и аэрокосмической отраслях промышленности).



Телефон: 8 (812) 309-75-97 (многоканальный)

Факс: 8 (812) 320-03-32

Электронная почта: ocean@oceanchips.ru

Web: <http://oceanchips.ru/>

Адрес: 198099, г. Санкт-Петербург, ул. Калинина, д. 2, корп. 4, лит. А