

IS31FL3726

16-BIT COLOR LED DRIVER WITH PWM CONTROL

June 2013

GENERAL DESCRIPTION

The IS31FL3726 is comprised of constant-current drivers designed for color LEDs. The output current value can be set using an external resistor. The output current value can be adjusted from 5mA to 60mA through the external resistor.

As a result, all outputs will have virtually the same current levels.

This driver incorporates 16-bit constant t-current outputs, a 16-bit shift register, a 16-bit latch and a 16-bit AND-gate circuit.

These drivers have been designed using the CMOS process.

FEATURES

- Output current capability and number of outputs: 60mA × 16 outputs
- Constant current range: 5mA to 60mA
- Application output voltage: ≥0.4V
- For anode-common LEDs
- Power supply voltage range, $V_{DD} = 3.3V$ to 5.5V
- Serial and parallel data transfer rate: 20MHz (Max. cascade connection)
- Operating temperature range, $T_A = -40^{\circ}C \sim +85^{\circ}C$
- Package: QFN-24 and TSSOP-24
- Current accuracy (All output on)

APPLICATIONS

- Cellular phones
- MP3/MP4/CD/minidiskplayers
- Toys

Output voltage	Current Accuracy		Output Current
	Between Bits	Between ICs	
≥0.4V	±4%	±20%	5mA ~ 60mA

BLOCK DIAGRAM

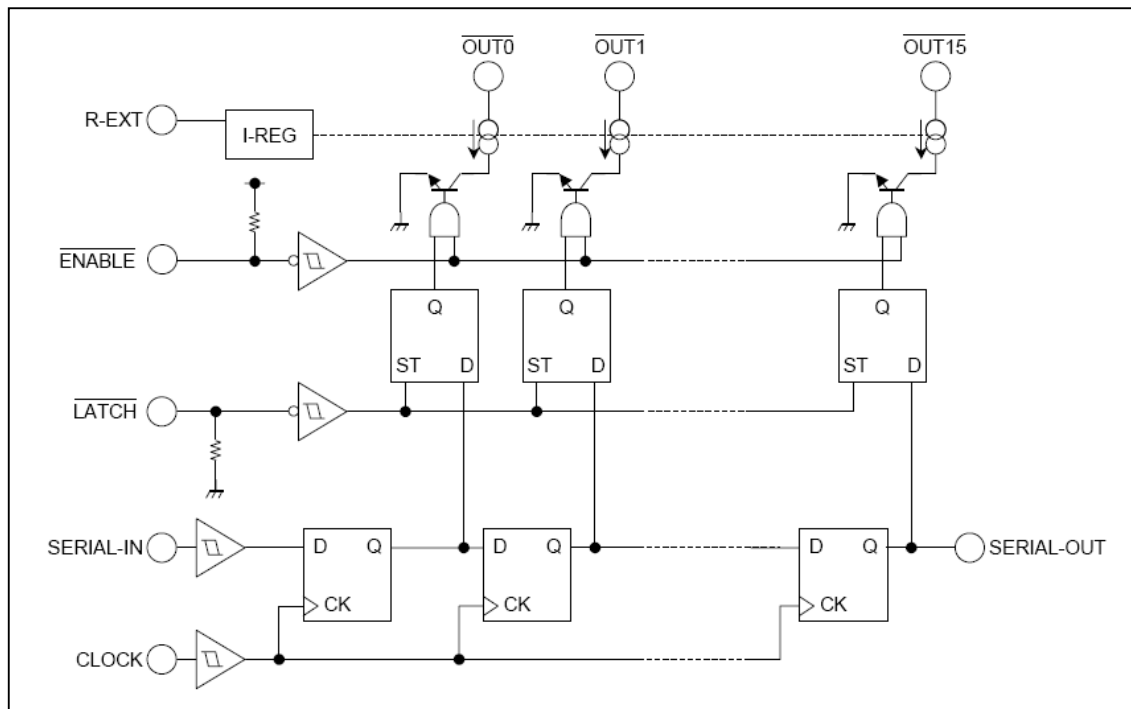

Figure 1 Block Diagram

IS31FL3726

TYPICAL APPLICATION CIRCUIT

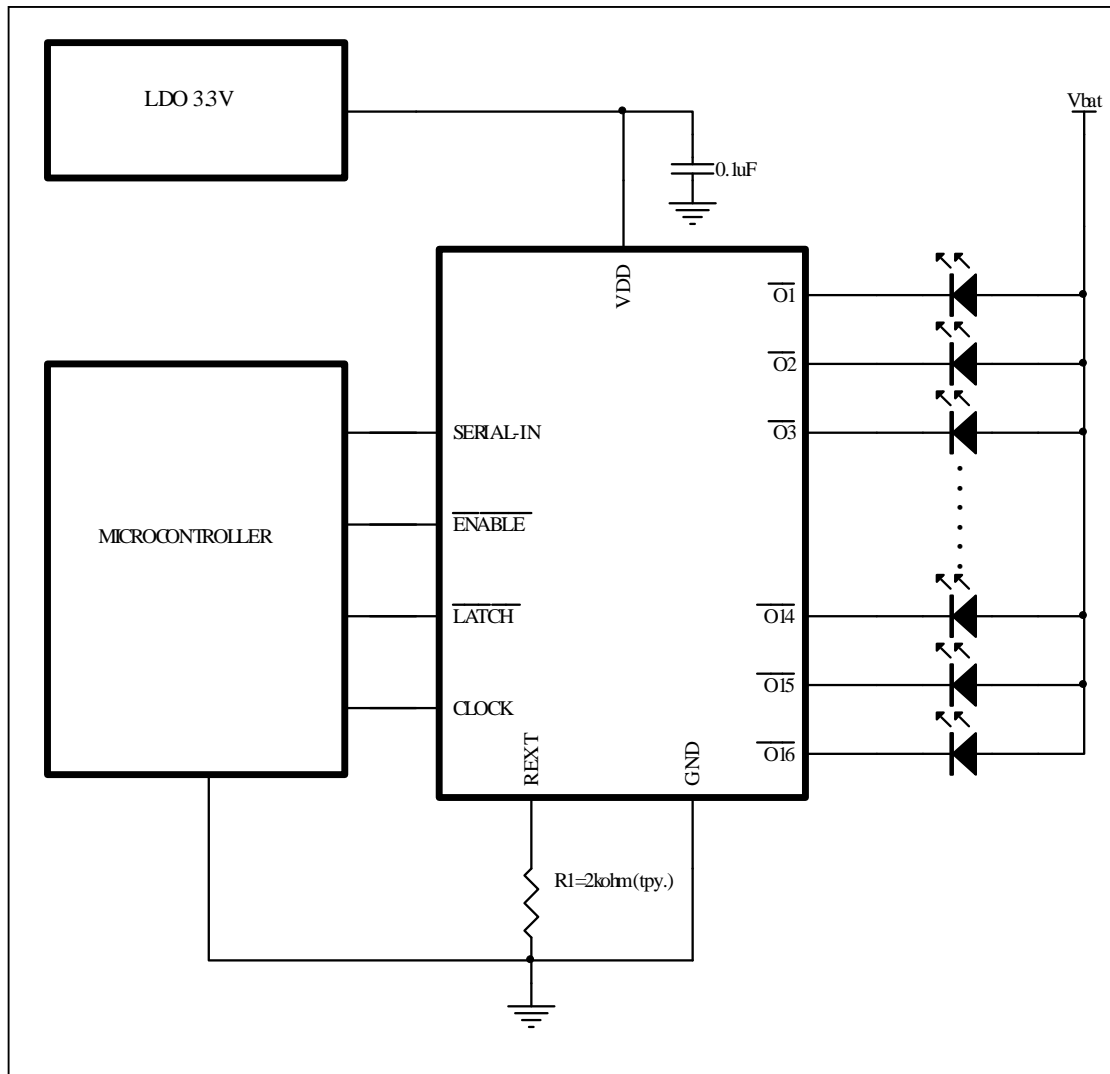
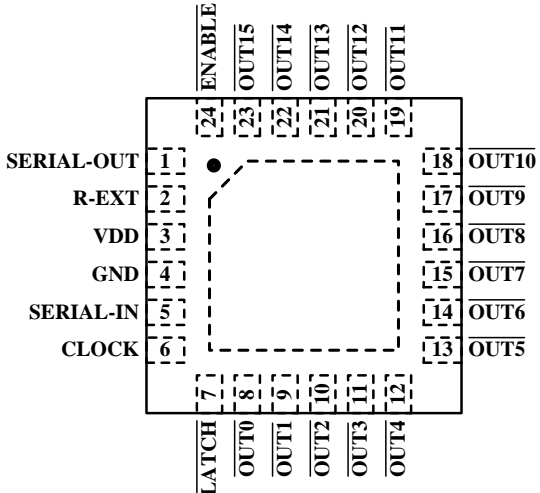
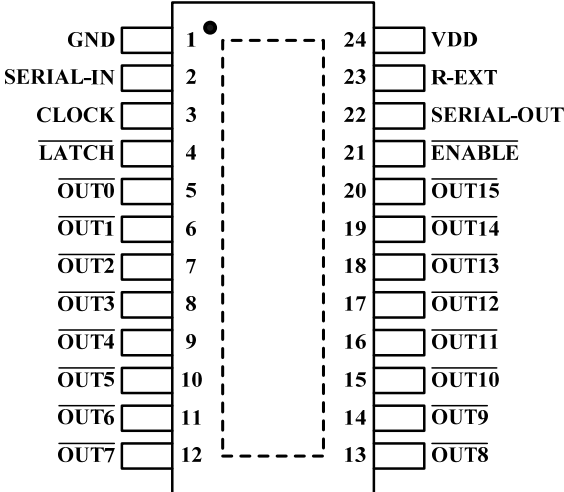

Figure 2 Typical Application Figure

IS31FL3726

PIN CONFIGURATION

Package	Pin Configuration (Top View)
QFN-24	
TSSOP-24	

IS31FL3726

PIN DESCRIPTION

No.		Pin	Description
QFN	TSSOP		
1	22	SERIAL-OUT	Output terminal for serial data input on SERIAL-IN terminal.
2	23	R-EXT	Input terminal used to connect an external resistor. This regulated the output current.
3	24	VDD	Supply voltage terminal.
4	1	GND	GND terminal for control logic.
5	2	SERIAL-IN	Input terminal for serial data for data shift register.
6	3	CLOCK	Input terminal for clock for data shift on rising edge.
7	4	$\overline{\text{LATCH}}$	Input terminal for data strobe. When the $\overline{\text{LATCH}}$ input is driven High, data is not latched. When it is pulled Low, data is latched.
8 ~ 23	5~20	$\overline{\text{OUT0}}\sim\overline{\text{OUT15}}$	Constant-current output terminals.
24	21	$\overline{\text{ENABLE}}$	Input terminal for output enable. All outputs ($\overline{\text{OUT0}}$ to $\overline{\text{OUT15}}$) are turned off, when the $\overline{\text{ENABLE}}$ terminal is driven High. And are turned on, when the terminal is driven Low.
		Thermal Pad	Connect to GND.



IS31FL3726

ORDERING INFORMATION

Industrial Range: -40°C to +85°C

Order Part No.	Package	QTY/Reel
IS31FL3726-QFLS2-TR	QFN-24, Lead-free	2500/Reel
IS31FL3726-ZLS2-TR	TSSOP-24, Lead-free	2500/Reel
IS31FL3726-ZLS2		62/Tube

Copyright © 2013 Integrated Silicon Solution, Inc. All rights reserved. ISSI reserves the right to make changes to this specification and its products at any time without notice. ISSI assumes no liability arising out of the application or use of any information, products or services described herein. Customers are advised to obtain the latest version of this device specification before relying on any published information and before placing orders for products. Integrated Silicon Solution, Inc. does not recommend the use of any of its products in life support applications where the failure or malfunction of the product can reasonably be expected to cause failure of the life support system or to significantly affect its safety or effectiveness. Products are not authorized for use in such applications unless Integrated Silicon Solution, Inc. receives written assurance to its satisfaction, that:

- a.) the risk of injury or damage has been minimized;
- b.) the user assume all such risks; and
- c.) potential liability of Integrated Silicon Solution, Inc is adequately protected under the circumstances

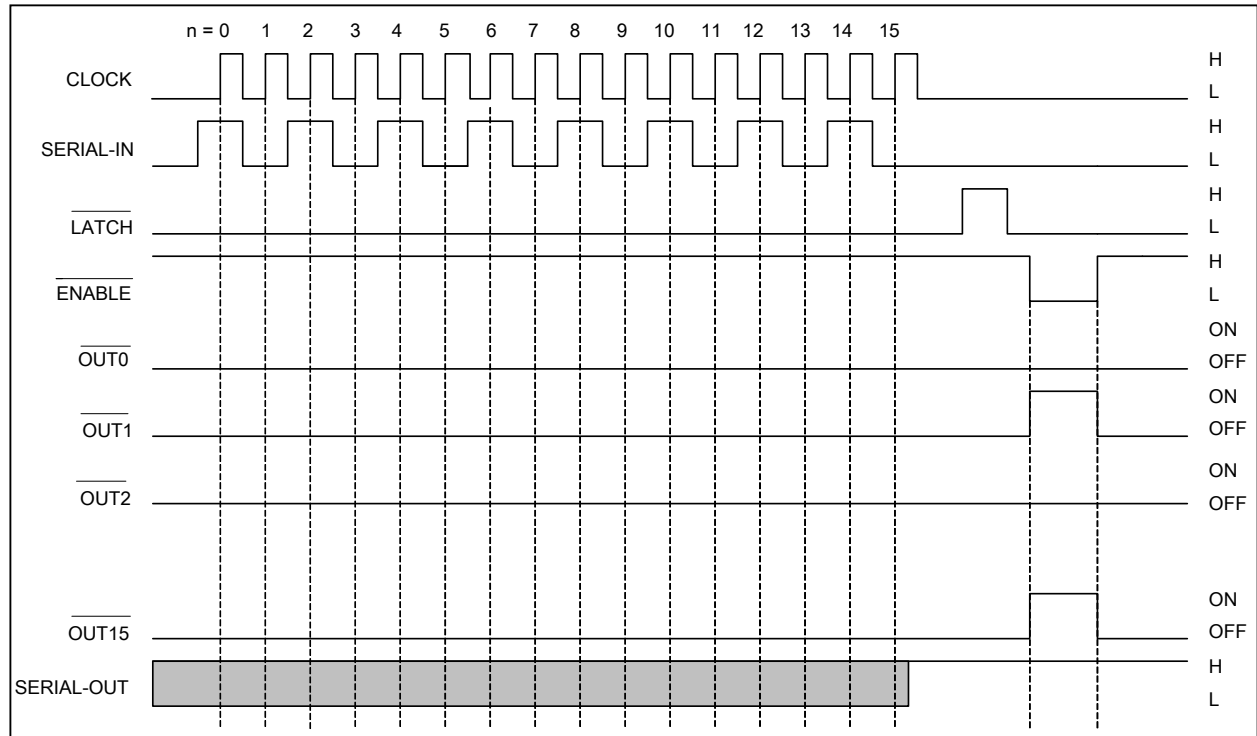

Figure 3 Timing Diagram

Warning: Latch circuit is leveled-latch circuit. Be careful because it is not triggered-latch circuit.

Note : The latches circuit holds data by pulling the `LATCH` terminal Low. And, when `LATCH` terminal is a High level, latch circuit doesn't hold data, and it passes from the input to the output. When `ENABLE` terminal is a Low level, output terminal `OUT0` to `OUT15` respond to the data, and on and off does. And, when `ENABLE` terminal is a High level, it offs with the output terminal regardless of the data.

Truth Table

CLOCK	LATCH	ENABLE	SERIAL-IN	OUT0 ...OUT7 ... OUT15	SERIAL-OUT
\uparrow	H	L	Dn	Dn ...Dn-7 ...Dn-15	Dn-15
\uparrow	L	L	Dn+1	No change	Dn-14
\uparrow	H	L	Dn+2	Dn+2 ...Dn-5 ...Dn-13	Dn-13
\downarrow	X	L	Dn+3	Dn+2 ...Dn-5 ...Dn-13	Dn-13
\downarrow	X	H	Dn+3	OFF	Dn-13

Note : `OUT0` to `OUT15` =On when Dn = H; `OUT0` to `OUT15` =Off when Dn = L. In order to ensure that the level of the power supply voltage is correct, an external resistor must be connected between R-EXT and GND.

Warning: The following conditions, `ENABLE=0`, `LATCH=1`, `SERIAL-IN=1`, cannot be configured at the same time when power on, or IS31FL3726 will be abnormal.



IS31FL3726

ABSOLUTE MAXIMUM RATINGS

Supply voltage, V_{DD}	-0.3V ~ +6.0V
Voltage at any input pin	-0.3V ~ $V_{DD}+0.2V$
Maximum junction temperature, T_{JMAX}	150°C
Storage temperature range, T_{STG}	-65°C ~ +150°C
Operating temperature range, T_A	-40°C ~ +85°C

Note:

Stresses beyond those listed under “Absolute Maximum Ratings” may cause permanent damage to the device. These are stress ratings only and functional operation of the device at these or any other condition beyond those indicated in the operational sections of the specifications is not implied. Exposure to absolute maximum rating conditions for extended periods may affect device reliability.

RECOMMENDED OPERATING CONDITION

$T_A = 25^\circ\text{C}$, unless otherwise specified.

Symbol	Characteristic	Condition	Min.	Typ.	Max.	Unit
V_{OUT}	Output voltage			0.7	4	V
f_{CLK}	Clock frequency (Note 1)	Cascade connected			20	MHz
t_{WLAT}	$\overline{\text{LATCH}}$ pulse width		50			ns
t_{WCLK}	CLOCK pulse width		25			ns
t_{WENA}	$\overline{\text{ENABLE}}$ pulse width (Note 1,2)	Upper $I_{OUT} = 20\text{mA}$	20			μs
		Lower $I_{OUT} = 20\text{mA}$	20			
t_{SETUP1}	Set-up time for CLOCK terminal		10			ns
t_{HOLD}	Hold time for CLOCK terminal		10			ns
t_{SETUP2}	Set-up time for $\overline{\text{LATCH}}$ terminal		50			ns

Note 1: Guaranteed by design.

Note 2: When the pulse of the Low level is input to the $\overline{\text{ENABLE}}$ terminal held in the High level.

IS31FL3726

ELECTRICAL CHARACTERISTICS

$T_A = 25^\circ\text{C}$, $V_{DD} = 3.3\text{V} \sim 5.5\text{V}$, unless otherwise specified.

Symbol	Characteristic	Condition		Min.	Typ.	Max.	Unit
V_{DD}	Supply voltage	Normal operation		3.3		5.5	V
I_{OUT1}	Output current	$V_{OUT} = 0.4\text{V}$ $V_{DD} = 3.3\text{V}$	$R_{EXT} = 1\text{k}\Omega$	15	18.7	22	mA
I_{OUT2}		$V_{OUT} = 0.4\text{V}$ $V_{DD} = 5.5\text{V}$		15	18.9	22	
ΔI_{OUT1}	Output current error between bits	$V_{OUT} \geq 0.4\text{V}$, All outputs on	$R_{EXT} = 1\text{k}\Omega$		± 3	± 4	%
I_{OZ}	Output leakage current input voltage	$V_{OUT} = 5.0\text{V}$				1	μA
V_{IH}	Input voltage			1.4			V
V_{IL}						0.4	
V_{OL}	SOUT terminal voltage	$I_{OL} = 1.0\text{mA}$, $V_{DD} = 3.3\text{V}$				0.3	V
		$I_{OL} = 1.0\text{mA}$, $V_{DD} = 5\text{V}$				0.3	
V_{OH}		$I_{OH} = -1.0\text{mA}$, $V_{DD} = 3.3\text{V}$		3			
		$I_{OH} = -1.0\text{mA}$, $V_{DD} = 5\text{V}$		4.7			
$\%/V_{DD}$	Output current supply voltage regulation	When V_{DD} is changed 3.3V to 5.5V			-1		%
$R_{(Up)}$	Pull-up resistor	ENABLE terminal		250	500	750	$\text{k}\Omega$
$R_{(Down)}$	Pull-down resistor	LATCH terminal					
$I_{DD(OFF)1}$	Supply current	$V_{OUT} = 5\text{V}$	$R_{EXT} = \text{OPEN}$		1		mA
$I_{DD(OFF)2}$		$V_{OUT} = 5\text{V}$ All outputs off	$R_{EXT} = 1\text{k}\Omega$		4.5		
$I_{DD(ON)1}$		$V_{OUT} = 0.7\text{V}$ All outputs on	$R_{EXT} = 1\text{k}\Omega$		5		

IS31FL3726

SWITCHING CHARACTERISTICS

T_A = 25°C, unless otherwise specified.

Symbol	Characteristic	Condition	Min.	Typ.	Max.	Unit
t _{pLH1}	Propagation delay	CLK-OUT _n , LATCH = "H" ENABLE = "L"		80	200	ns
t _{pLH2}		LATCH-OUT _n , ENABLE = "L"		80	200	
t _{pLH3}		ENABLE-OUT _n , LATCH = "H"		2000		
t _{pLH}		CLK-SERIAL OUT	3	5		
t _{pHL1}		CLK-OUT _n , LATCH = "H" ENABLE = "L"		160	250	
t _{pHL2}		LATCH-OUT _n , ENABLE = "L"		160	250	
t _{pHL3}		ENABLE-OUT _n , LATCH = "H"		200	350	
t _{pLH}		CLK-SERIAL OUT	4	6		
t _{or}	Output rise time	10%~90% of voltage waveform	30	150	200	ns
t _{of}	Output fall time	90%~10% of voltage waveform	150	200	250	ns
t _r	Maximum CLOCK rise time	When not on PCB (Note)			5	us
t _f	Maximum CLOCK fall time				5	us

Conditions: (Refer to test circuit.)

T_{opr} = 25°C, V_{DD}=V_{IH} = 3.3V and 5V, V_{OUT} = 0.7V, V_{IL} = 0V, R_{EXT} = 1000Ω, V_L = 3.0V, R_L = 60Ω, C_L = 10.5pF

Note:

1. If the device is connected in a cascade and tr/tf for the waveform is large, it may not be possible to achieve the timing required for data transfer. Please consider the timings carefully.
2. Delay between outputs. The IS31FL3726 has graduated delay circuits between outputs. The fixed delay time is 5ns (typical), OUT1 has 5ns delay, OUT2 has 10 ns delay, etc. This delay prevents large inrush currents, which reduce power supply bypass capacitor requirements when the outputs turn on. The delay works during switch on and switch off of each output channel. LEDs that have not turned on before ENABLE is low will still turn on and off at the determined delayed time regardless of the state of ENABLE. Therefore, every LED will be illuminated for the amount of time ENABLE is pulled high.

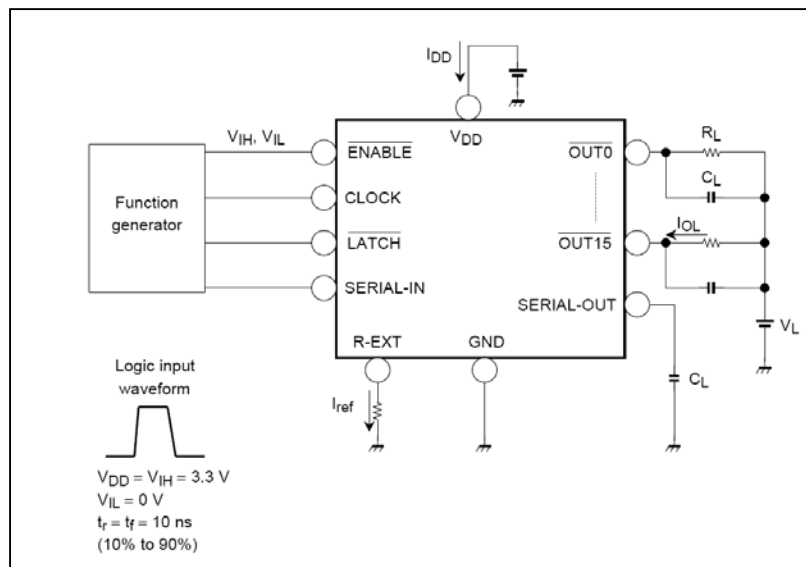
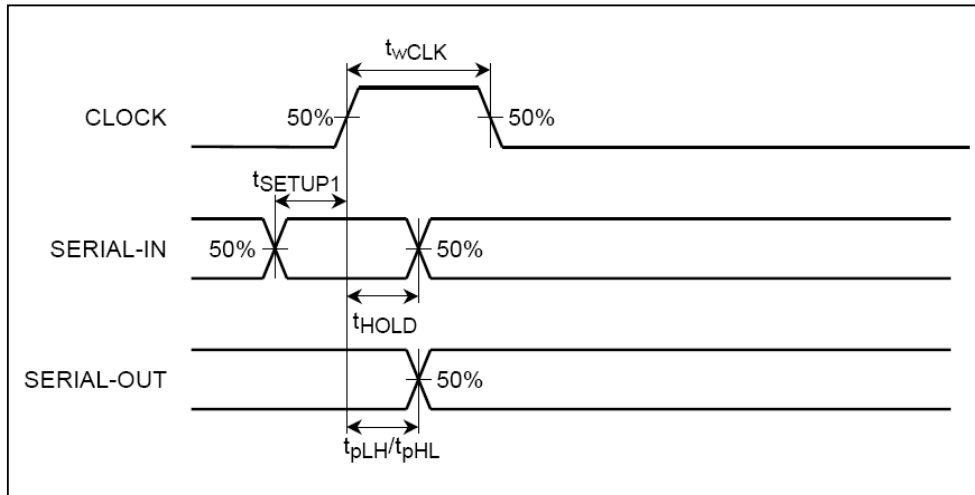

Figure 4 Test Diagram

IS31FL3726

TIMING WAVEFORM

1. CLOCK, SERIAL-IN, SERIAL-OUT



2. CLOCK, SERIAL-IN, LATCH, ENABLE, OUTn

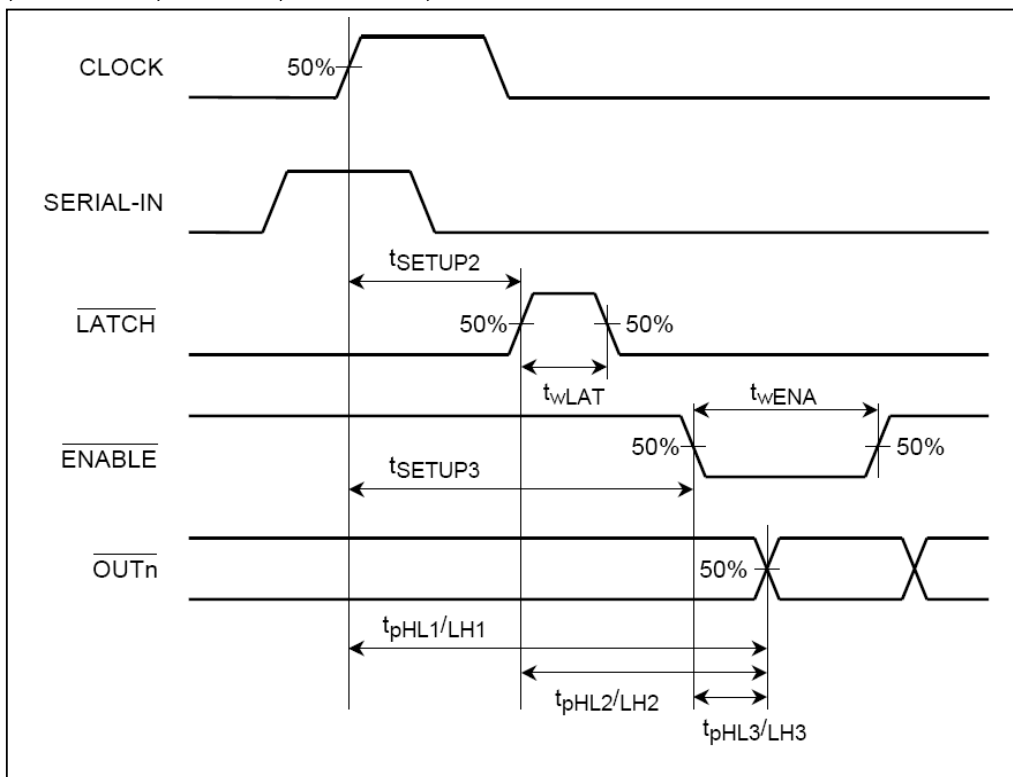

3. OUTn

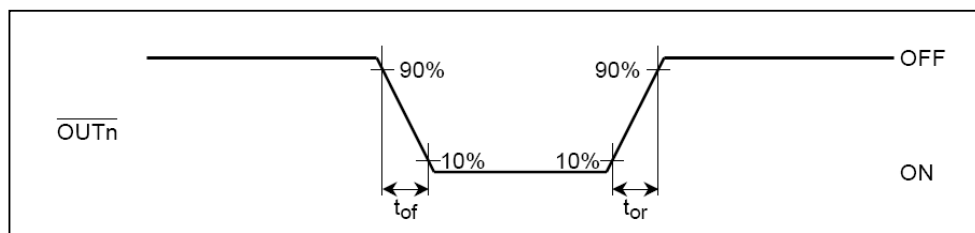

IS31FL3726

TYPICAL OPERATING CHARACTERISTICS

ADJUSTING OUTPUT CURRENT

The output current of each channel is set by an external resistor R_{ext} , the relationship between I_{out} and R_{ext} is:

$$I_{out} = (V_{R-ext}/R_{ext}) \times 52$$

the V_{R-ext} is 0.36V in the IS31FL3726,so we can count the I_{out} as :

$$I_{out} = 0.36 \times 52 / R_{ext}$$

As show in the figure below:

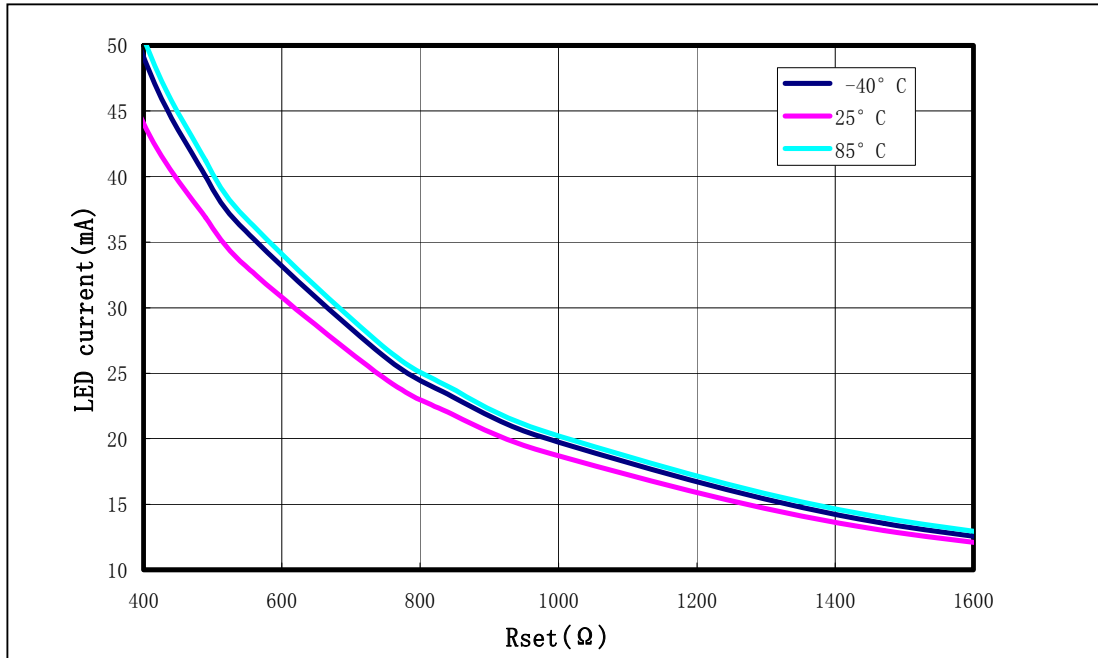

IS31FL3726

CLASSIFICATION REFLOW PROFILES

Profile Feature	Pb-Free Assembly
Preheat & Soak Temperature min (T _{smin}) Temperature max (T _{smax}) Time (T _{smin} to T _{smax}) (t _s)	150°C 200°C 60-120 seconds
Average ramp-up rate (T _{smax} to T _p)	3°C/second max.
Liquidous temperature (T _L) Time at liquidous (t _L)	217°C 60-150 seconds
Peak package body temperature (T _p)*	Max 260°C
Time (t _p)** within 5°C of the specified classification temperature (T _c)	Max 30 seconds
Average ramp-down rate (T _p to T _{smax})	6°C/second max.
Time 25°C to peak	8 minutes max.

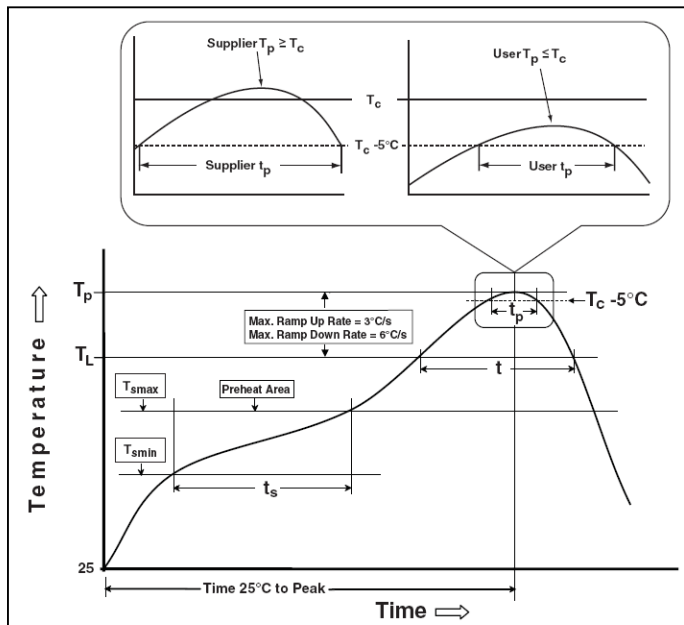
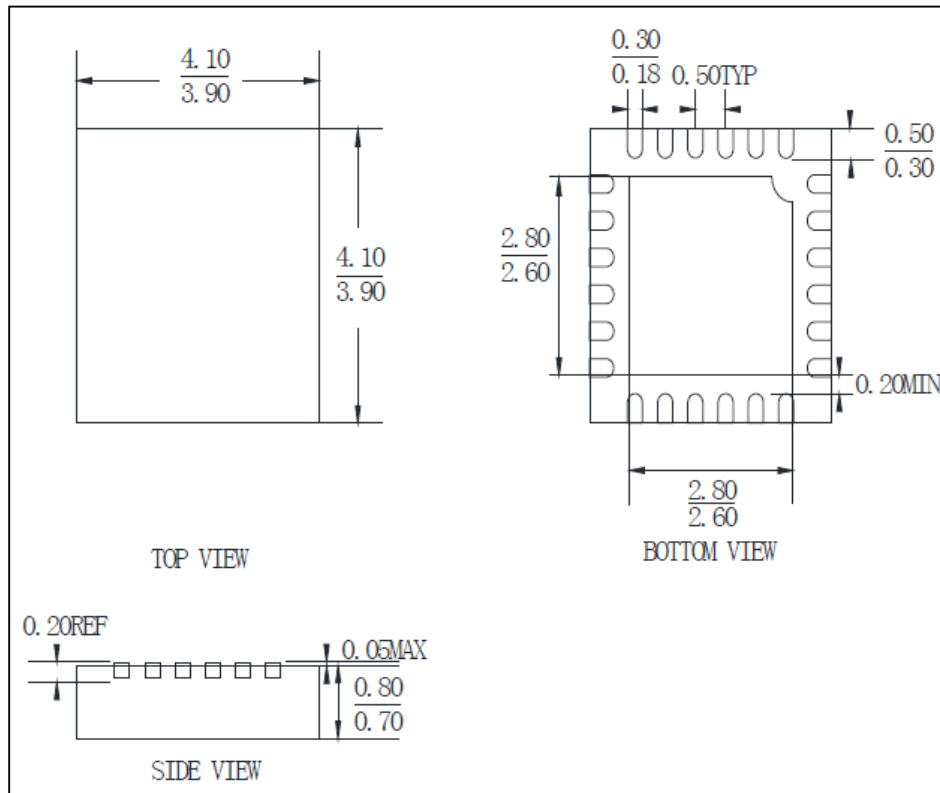

Figure 5 Classification Profile

IS31FL3726

PACKAGE INFORMATION

QFN-24



Note: All dimensions in millimeters unless otherwise stated.

IS31FL3726

TSSOP-24

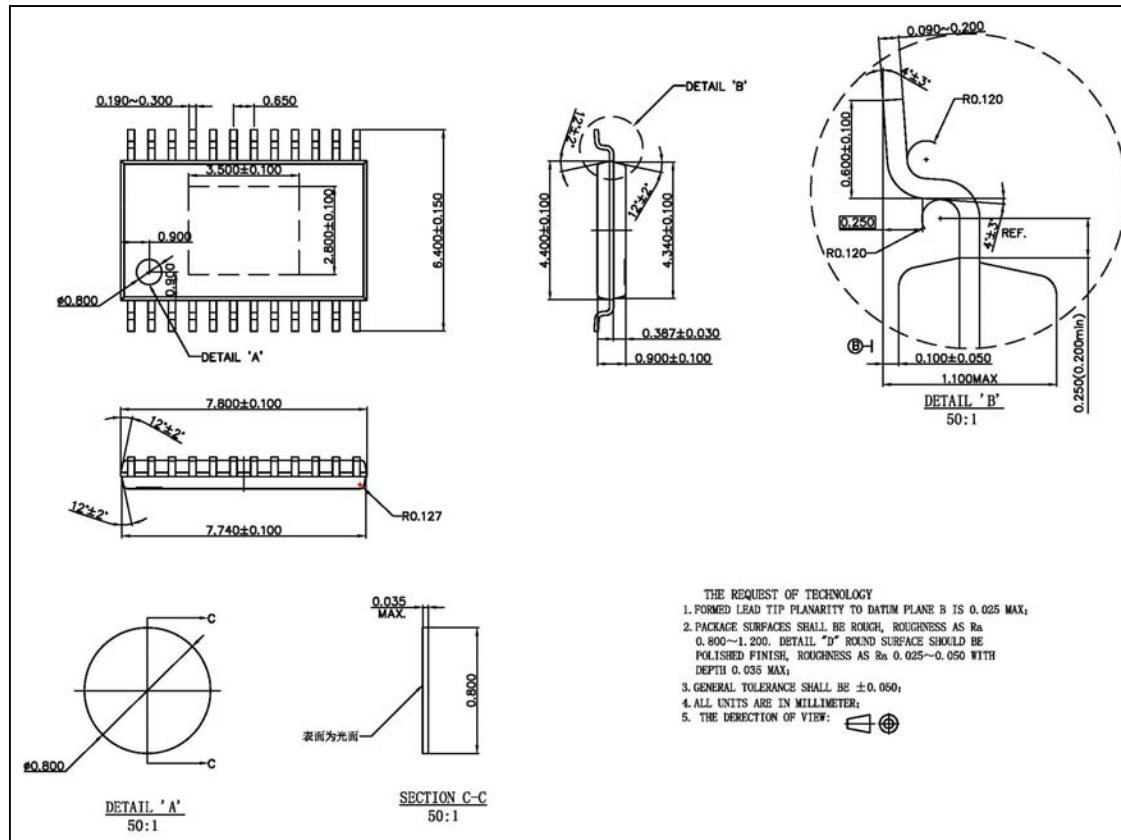

Note: All dimensions in millimeters unless otherwise stated.

Компания «Океан Электроники» предлагает заключение долгосрочных отношений при поставках импортных электронных компонентов на взаимовыгодных условиях!

Наши преимущества:

- Поставка оригинальных импортных электронных компонентов напрямую с производств Америки, Европы и Азии, а так же с крупнейших складов мира;
- Широкая линейка поставок активных и пассивных импортных электронных компонентов (более 30 млн. наименований);
- Поставка сложных, дефицитных, либо снятых с производства позиций;
- Оперативные сроки поставки под заказ (от 5 рабочих дней);
- Экспресс доставка в любую точку России;
- Помощь Конструкторского Отдела и консультации квалифицированных инженеров;
- Техническая поддержка проекта, помощь в подборе аналогов, поставка прототипов;
- Поставка электронных компонентов под контролем ВП;
- Система менеджмента качества сертифицирована по Международному стандарту ISO 9001;
- При необходимости вся продукция военного и аэрокосмического назначения проходит испытания и сертификацию в лаборатории (по согласованию с заказчиком);
- Поставка специализированных компонентов военного и аэрокосмического уровня качества (Xilinx, Altera, Analog Devices, Intersil, Interpoint, Microsemi, Actel, Aeroflex, Peregrine, VPT, Syfer, Eurofarad, Texas Instruments, MS Kennedy, Miteq, Cobham, E2V, MA-COM, Hittite, Mini-Circuits, General Dynamics и др.);

Компания «Океан Электроники» является официальным дистрибьютором и эксклюзивным представителем в России одного из крупнейших производителей разъемов военного и аэрокосмического назначения «JONHON», а так же официальным дистрибьютором и эксклюзивным представителем в России производителя высокотехнологичных и надежных решений для передачи СВЧ сигналов «FORSTAR».



JONHON

«JONHON» (основан в 1970 г.)

Разъемы специального, военного и аэрокосмического назначения:

(Применяются в военной, авиационной, аэрокосмической, морской, железнодорожной, горно- и нефтедобывающей отраслях промышленности)

«FORSTAR» (основан в 1998 г.)

ВЧ соединители, коаксиальные кабели, кабельные сборки и микроволновые компоненты:

(Применяются в телекоммуникациях гражданского и специального назначения, в средствах связи, РЛС, а так же военной, авиационной и аэрокосмической отраслях промышленности).



Телефон: 8 (812) 309-75-97 (многоканальный)

Факс: 8 (812) 320-03-32

Электронная почта: ocean@oceanchips.ru

Web: <http://oceanchips.ru/>

Адрес: 198099, г. Санкт-Петербург, ул. Калинина, д. 2, корп. 4, лит. А