

Specification

Patent Pending

- Part No. : **Accura UWC.40**
- Description : 3~5GHz Ultra-Wide Band (UWB)
SMD Chip Antenna
- Features : SMD Chip UWB Antenna
For European and USA UWB Applications
In Channels 1-4
- Uses
- Automotive sensors
 - Smart airbags
 - Precision surveying
 - Smart home and entertainment systems
 - Centimeter Level Positioning

Frequency: 3.1-4.75GHz

Dimensions: 6*7*3mm

RoHS Compliant

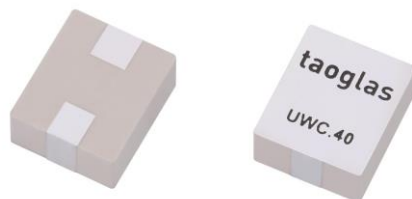

1. Introduction

The UWC.40 chip antenna, at 6*7*3 mm, is a small form factor Ultra-Wideband (UWB) antenna with high efficiencies across the pulsed UWB communications operational bands. It enables designers to use just one antenna to simultaneously cover all common UWB commercial bands, namely bands 1-4. UWC.40 provides a peak gain of 4 dBi and efficiencies of more than 80% across most of the UWB bandwidth.

The UWC.40 antenna is a durable ceramic antenna designed to be mounted directly to a PCB via standard SMT reflow process. It is an ideal choice for any device maker that needs to keep manufacturing costs down over the lifetime of a product. Care should be taken to mount the antenna at least 1mm from metal components or surfaces, and ideally 5mm for best Radiation efficiency. Nearby metal components should be as small as possible. The antenna will not work within fully enclosed metal enclosures. Minimum recommended ground plane size is 26 mm x 20 mm, and antenna to ground clearance is fixed to 2.5 mm and should not be changed. (Please see section 7. Application Note)

Ultra-Wideband (also known as UWB) is a low power digital wireless technology for transmitting large amounts of digital data over a wide spectrum of frequency bands typically spanning more than 500MHz with very low power for short distances.

The low power requirements of UWB mean increased battery life of sensors and tags leading to reduction in overall operational costs. Taoglas has developed various innovative and new-to-market flexible embedded UWB antennas designed for seamless integration on plastics and using highly flexible micro-coaxial cable mounting while achieving high performance where space is limited. Taoglas UWB series antennas have been designed for use with the recently launched Decawave ScenSor DW1000 module and are also compatible with any other UWB sensor modules on the market.



Note that any embedded antenna is subject to detuning and radiation efficiency decreases in any device environment. Taoglas has a range of services that can characterize the antenna performance in your device and also select and optimize the right antenna for your application. Subject to a minimum order quantity, a fully custom antenna can also be designed and supplied. Check our UWB services pages on our website or contact your regional Taoglas office for more information.

1.1. Applications of Pulsed UWB antenna Technology

Radar - These short-pulsed antennas provide very fine range resolution and precision distance and positioning measurement capabilities. UWB signals enable inexpensive high definition radar antennas which find use in automotive sensors, smart airbags, and precision surveying applications amongst many others.

Home Network Connectivity - Smart home and entertainment systems can take advantage of high data rates for streaming high quality audio and video contents in real time for consumer electronics and computing within a home environment.

Position location & Tracking - UWB antennas also find use in Position Location and Tracking applications such as locating patients in case of critical condition, hikers injured in remote areas, tracking cars, and managing a variety of goods in a big shopping mall. UWB offers better noise immunity and better accuracy to within a few cm compared to current localization technologies such as Assisted GPS for Indoors, Wi-Fi and cellular which are at best able to offer meter level precision. Tethered Indoor positioning UWB systems that measure the angles of arrival of ultra-wideband (UWB) radio signals perform triangulation by using multiple sensors to communicate with a tag device.

2. Specification

Electrical				
STANDARD	USA UWB Channel 1	USA UWB Channel 2	USA UWB Channel 3	USA UWB Channel 4
Operation Frequency (GHz)	3.24-3.74	3.74-4.24	4.24-4.74	3.32-4.65
Return Loss (dB)	<-7.5	<-6.5	<-5	<-5
Efficiency (%)	>82%	>80%	>55%	>65%
Peak Gain (dBi)	3.5	4.5	4	4
Max VSWR	2.5:1	2.8:1	3.8:1	2.8:1
Radiation Properties	Omnidirectional			
Polarization	Linear			
Impedance	50 Ω			
Max Input Power	10 W			
Mechanical				
Dimension	6 x 7 x 3 mm			
Material	Ceramic			
Weight				
Environmental				
Operation Temperature	-40°C to 85°C			
Storage Temperature	-40°C to 85°C			
Humidity	40% to 90%			

* Results obtained for antenna on Standard Evaluation Board size 37*20mm, with 26*20mm ground plane.

See Section 4 for Standard Evaluation Board details.

3. Antenna Characteristics

3.1. Return Loss

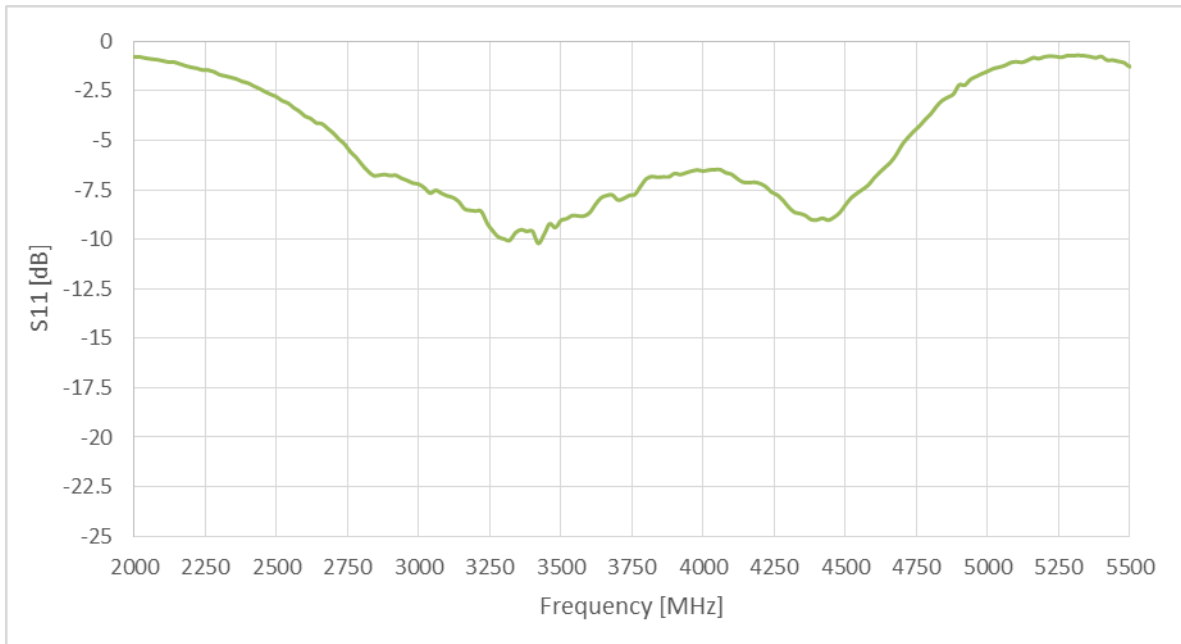

3.2. VSWR

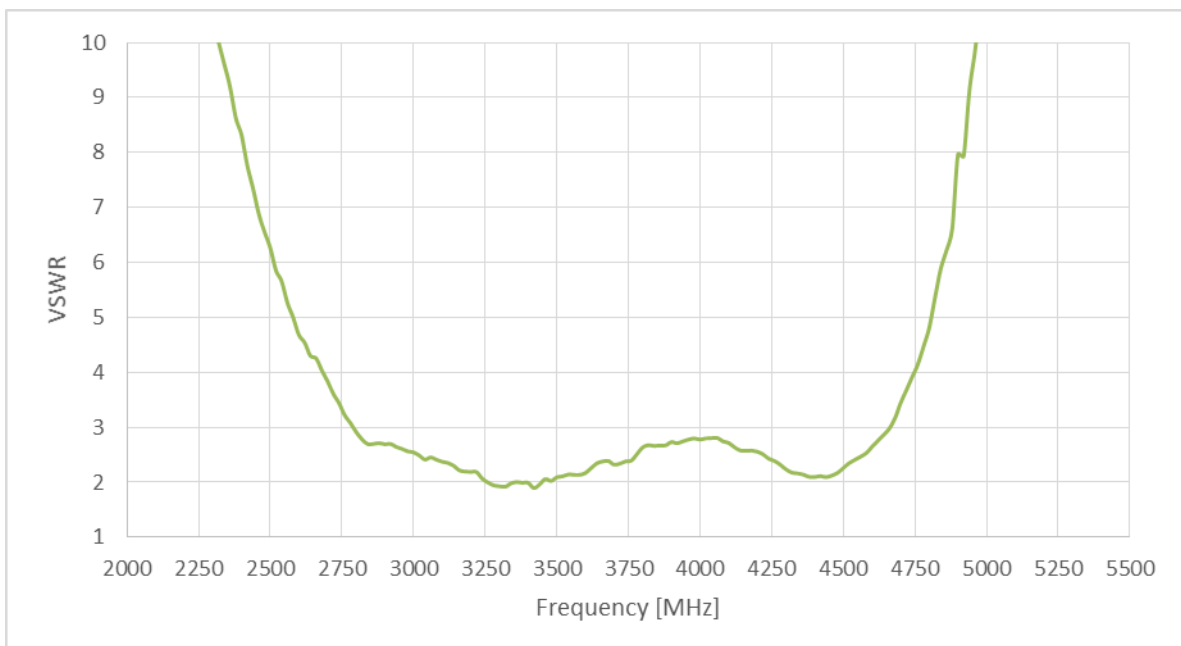



3.3. Efficiency

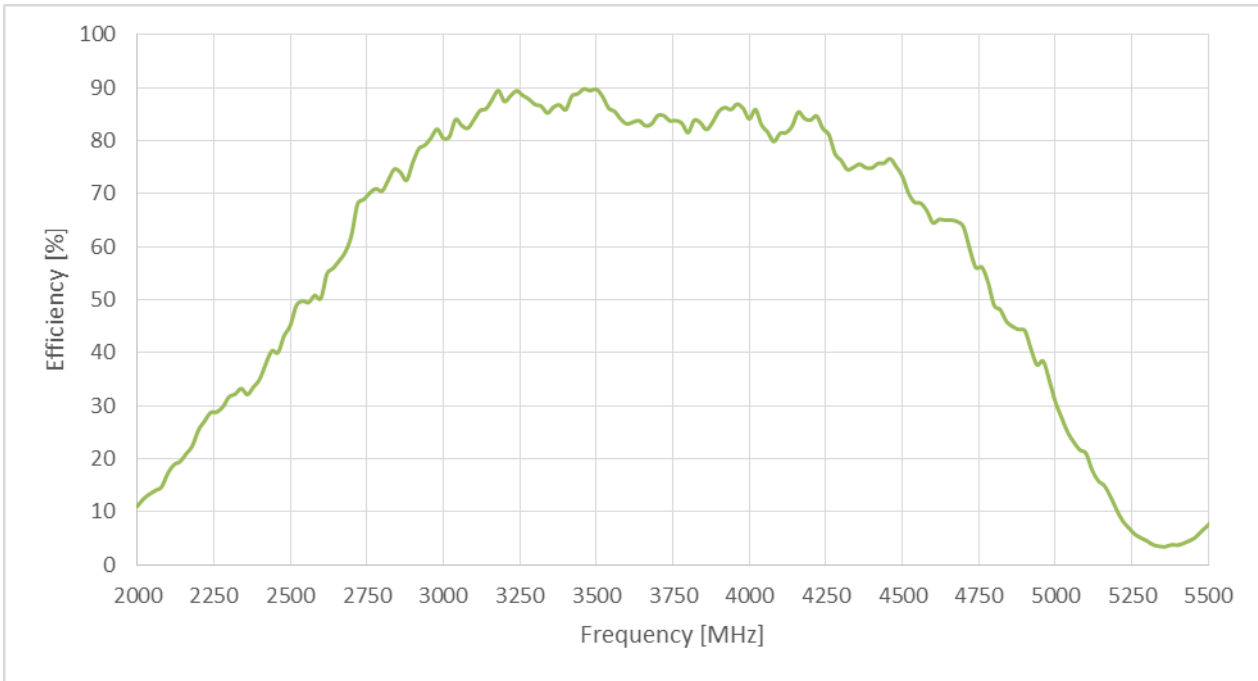

3.4. Peak Gain

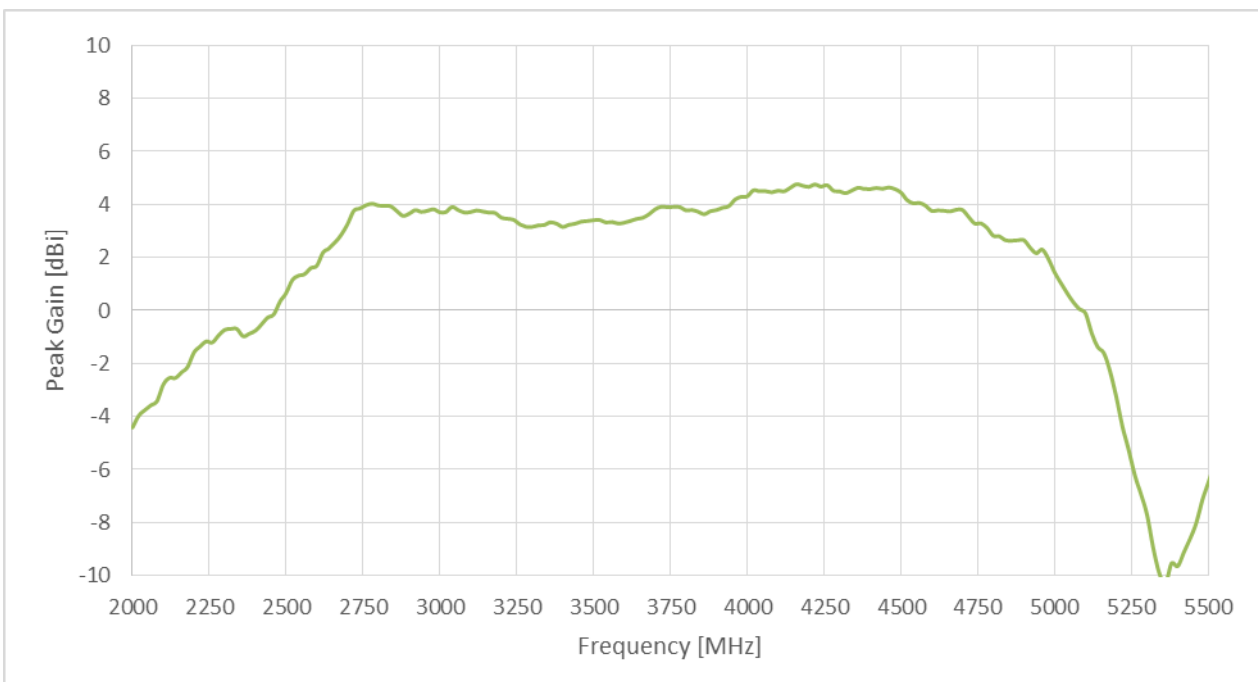

3.5. Average Gain

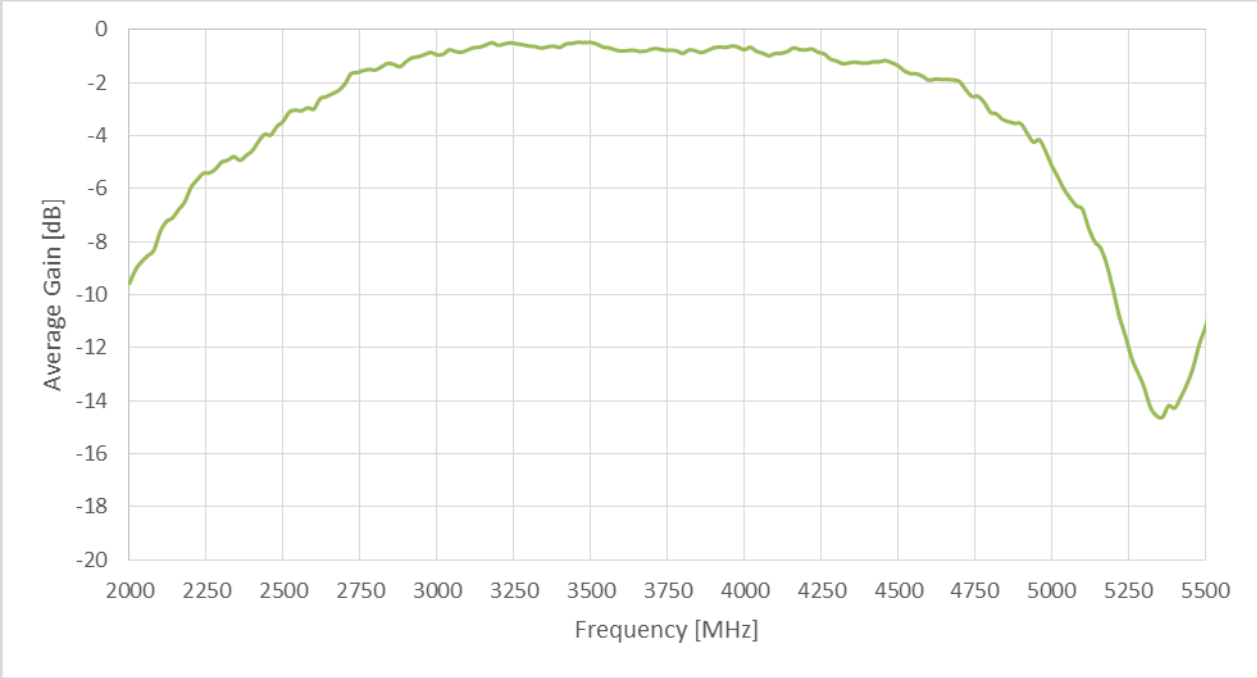

3.6. Antenna Radiation Pattern

3.6.1. Measurement Setup

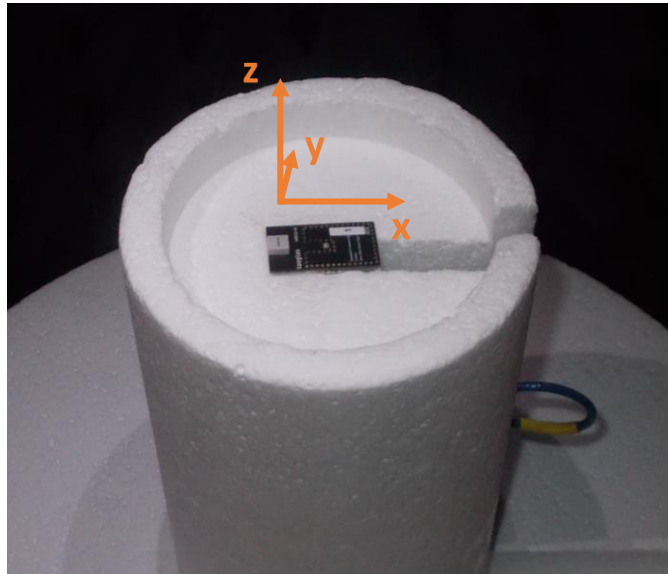

3.6.2. 2D Radiation Pattern (dBi)

XY Plane

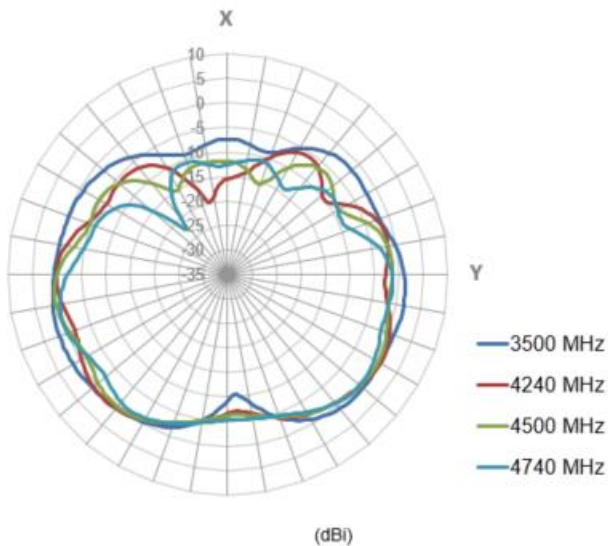

YZ Plane

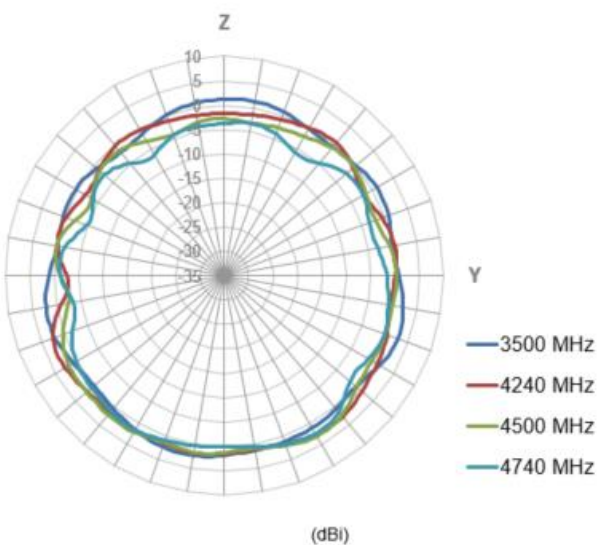

XZ Plane

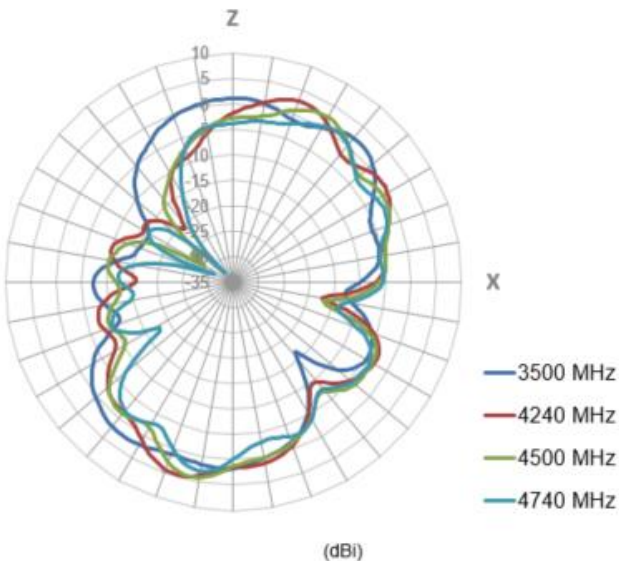

3.6.3. 3D Radiation Pattern (dBi)

3.5 GHz

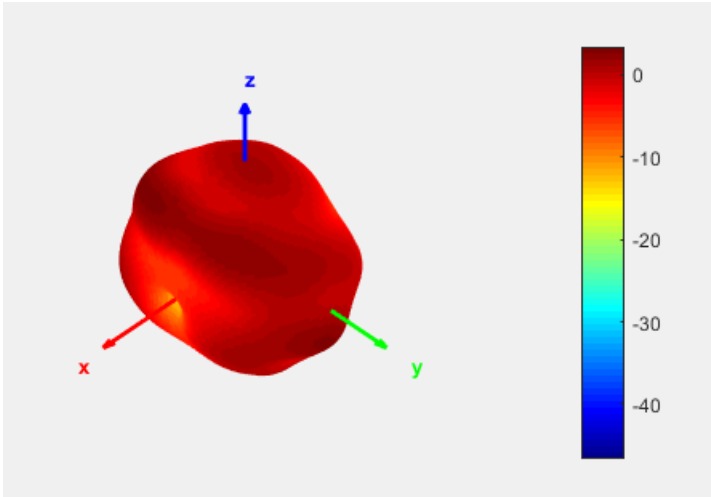

4 GHz

4.74 GHz

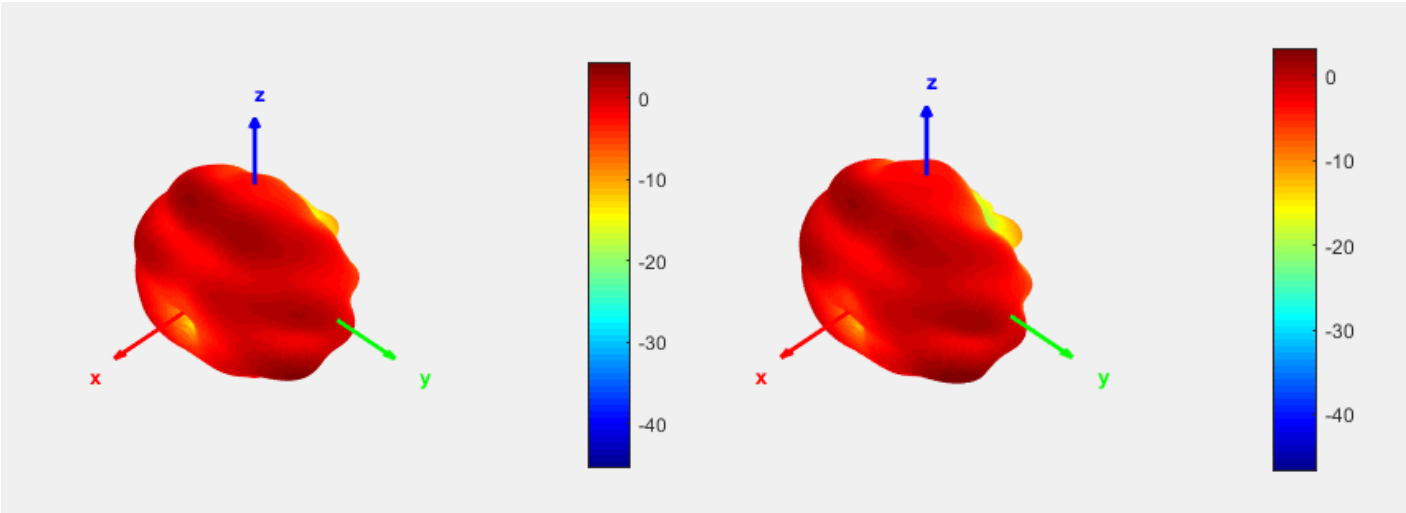

3.7. Group Delay vs. Angle (YZ Plane) in UWB channel 2 (4 GHz)

Total system group delay includes the propagation delay in the transmitting antenna (Tx), propagation channel (Ch), and receiving antenna (Rx). Group delay can vary across directions of propagation (theta or phi angles). This group delay variation over theta or phi represents output signal distortions and should be known and minimized if possible.

The measured and normalized group delay value for UWC.40 is presented below for 4 principal angles in the YZ plane, measured at 4 GHz (UWB channel 2). A group delay variation of 100-150 ps is considered excellent for UWB system implementation. The observed group delay variation of 182 ps for UWC.40 will provide very good performance.

The measurements were performed using the EVK1000 Decawave kit with the UWC.40 antenna as both the receiver and AUT device.

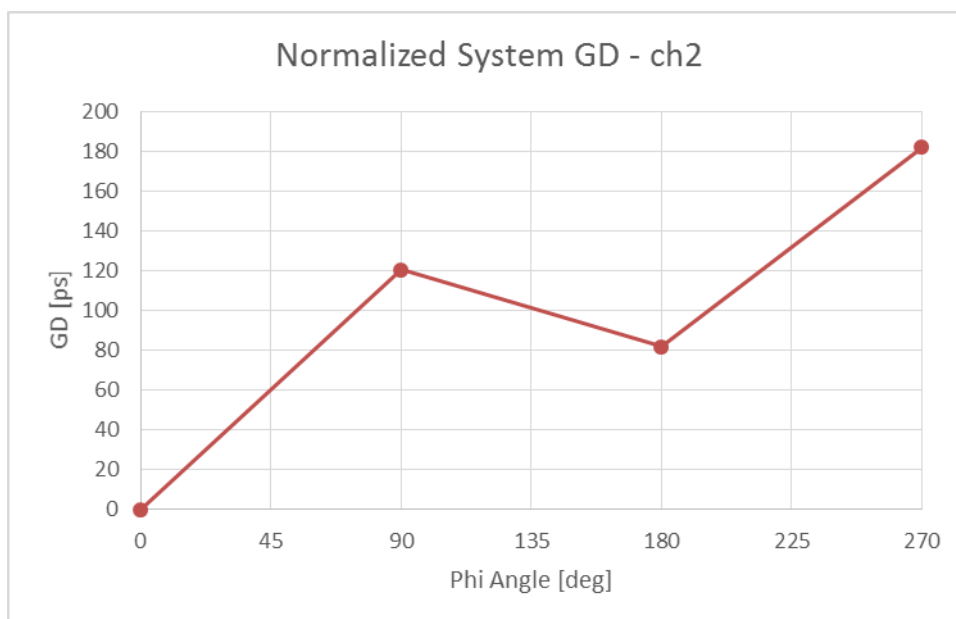

3.8. Fidelity Factor vs. Angle (YZ Plane) in UWB channel 2 (4 GHz)

The fidelity is above 0.9 (benchmark value) for all angles, therefore UWC.40 shows excellent performance.



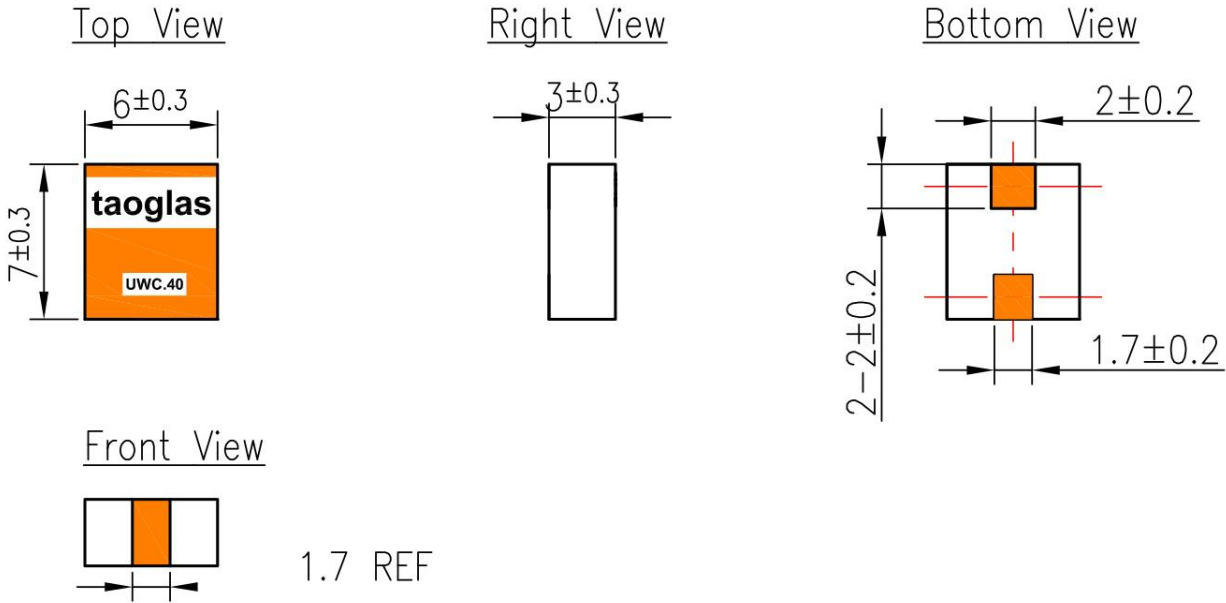

UWC.40 Fidelity Factor	
Angle	Fidelity Factor
0°	0.99
45°	0.99
90°	0.99
135°	0.99
180°	0.99

4. Mechanical Drawing

4.1. Antenna Drawing (Unit: mm)



NOTE:

- 1. Ag Plated area 
- 2. Solder Mask area 
- 3. Copper area 
- 4. Paste area 
- 5. Copper Keepout Area 

- 6. Ground keepout should extend from top layer through all inner PCB layers to minimize coupling from RF feed to ground.
- 7. Any vias in pads should be either filled or tented to prevent solder from wicking away from the pad during reflow.
- 8. The dimension tolerances should follow standard PCB manufacturing guidelines

4.2. Recommended PCB Layout

4.2.1. Top Copper

Pad 2 should be connected to a 50 ohm transmission line

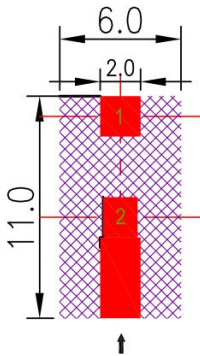

→ :Connected to 50 ohm transmission line.

4.2.2. Top Solder Paste

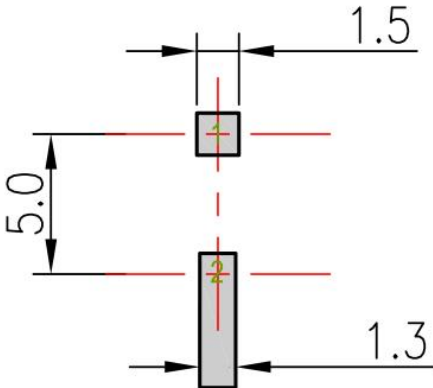

NOTE:

- 1. Ag Plated area
- 2. Solder Mask area
- 3. Copper area
- 4. Paste area
- 5. Copper Keepout Area



- 6. Ground keepout should extend from top layer through all inner PCB layers to minimize coupling from RF feed to ground.
- 7. Any vias in pads should be either filled or tented to prevent solder from wicking away from the pad during reflow.
- 8. The dimension tolerances should follow standard PCB manufacturing guidelines

4.2.3. Top Solder Mask

This drawing is a negative of solder mask. Black regions are anti-mask.

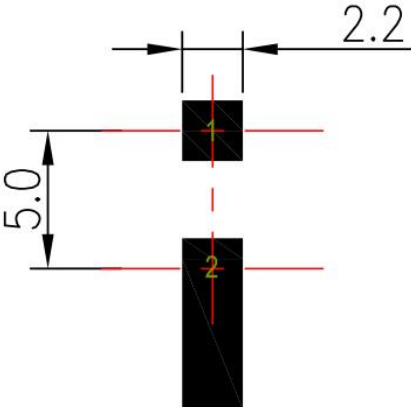

4.2.4. Composite Diagram

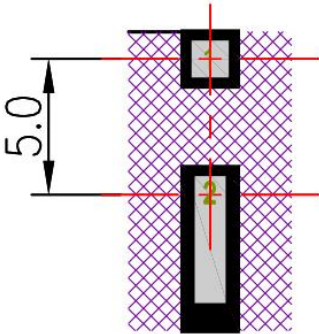

NOTE:

- 1. Ag Plated area
- 2. Solder Mask area
- 3. Copper area
- 4. Paste area
- 5. Copper Keepout Area



- 6. Ground keepout should extend from top layer through all inner PCB layers to minimize coupling from RF feed to ground.
- 7. Any vias in pads should be either filled or tented to prevent solder from wicking away from the pad during reflow.
- 8. The dimension tolerances should follow standard PCB manufacturing guidelines



4.3. Evaluation Board

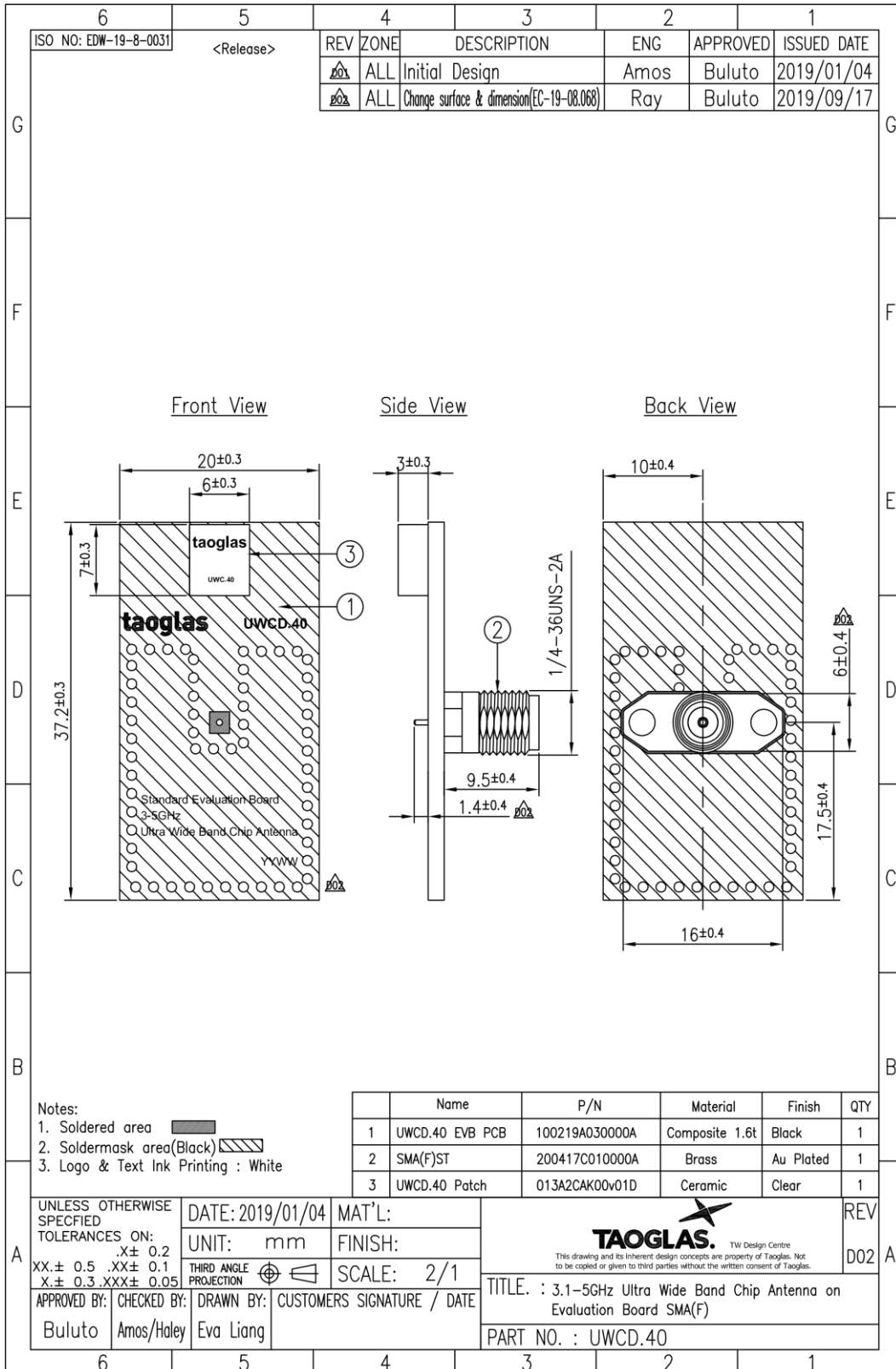



5. Packaging

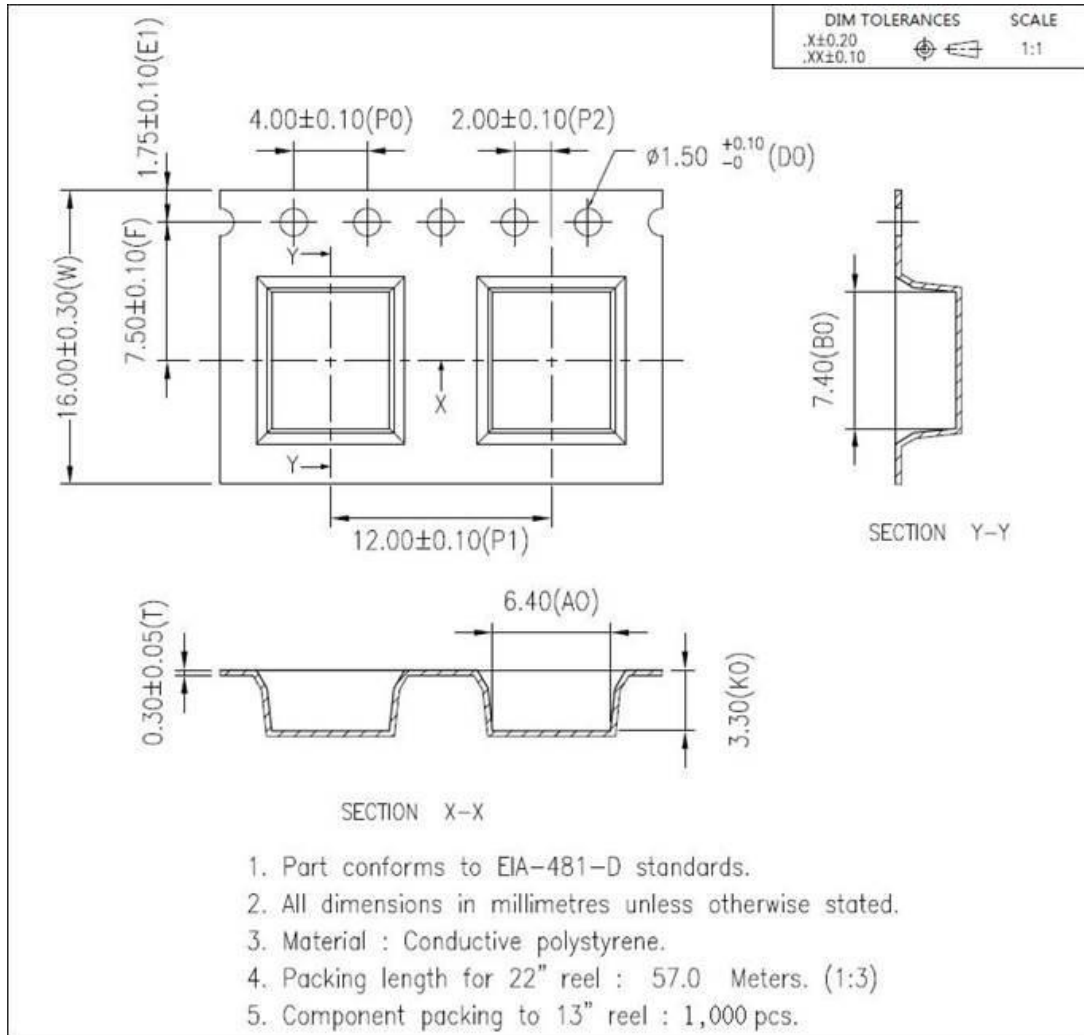



TAOGLAS®

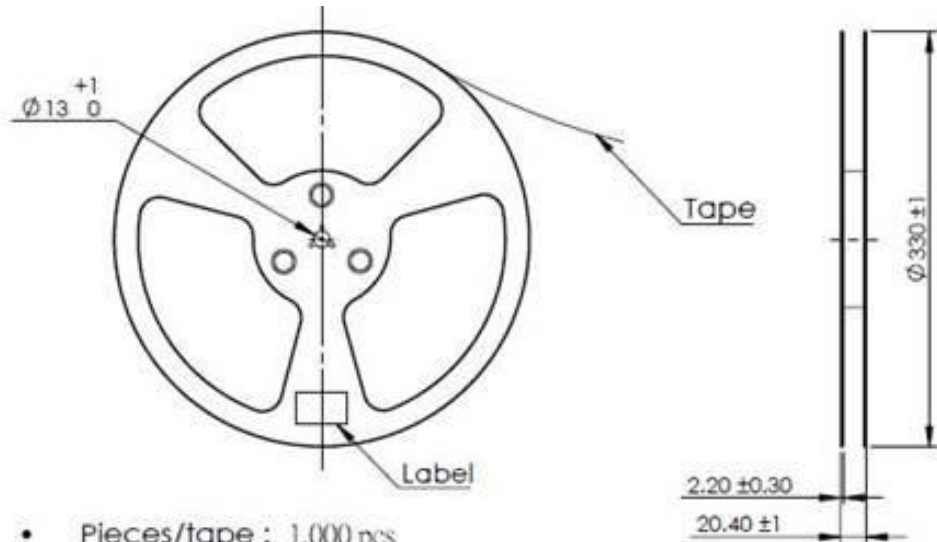

- Pieces/tape : 1,000 pcs
- Tape drawing please access the second page to review

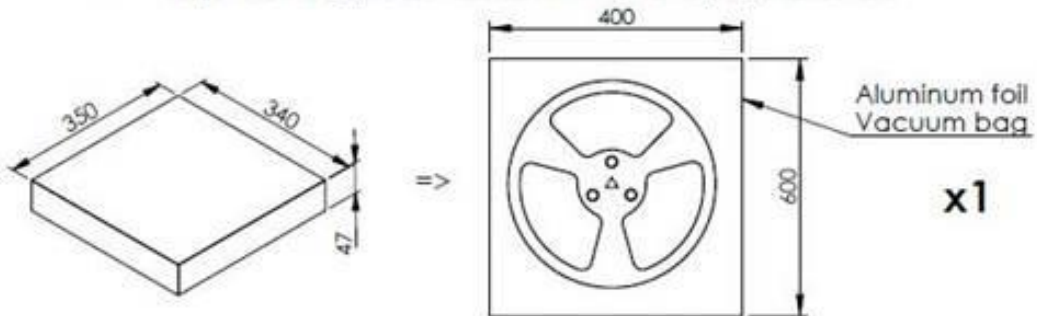

- Carton inside(350 x 340 x 47) contained **1 reel** (1,000 pcs)

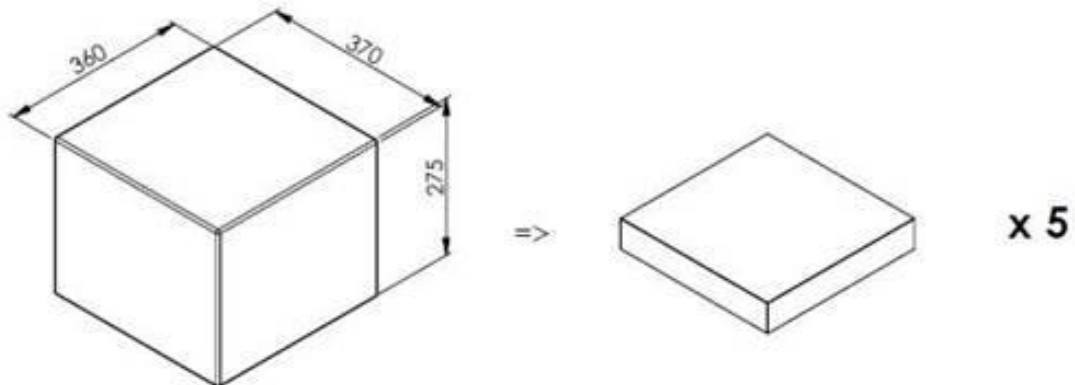

One carton box contained 5 box =>
5000 Units/Carton-Outside - Dimension 370x360x275

6. Application Notes

6.1. Ground Plane Size

The influence of ground plane length and width on UWC.40 performance is presented below. Increasing the ground plane length does not have a significant impact on efficiency but does affect return loss (S11). Ground plane lengths of less than 26mm are not recommended.

Increasing the ground plane width affects both S11 and efficiency in the high frequency region. Ground plane width greater than 40 mm is not recommended if channel 2 will be used.

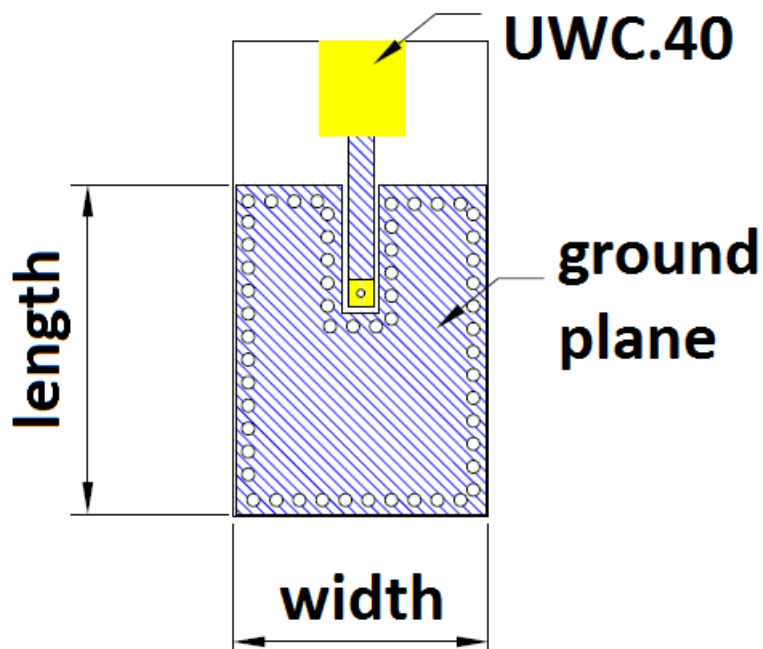

Figure 1 - Evaluation Board Layout

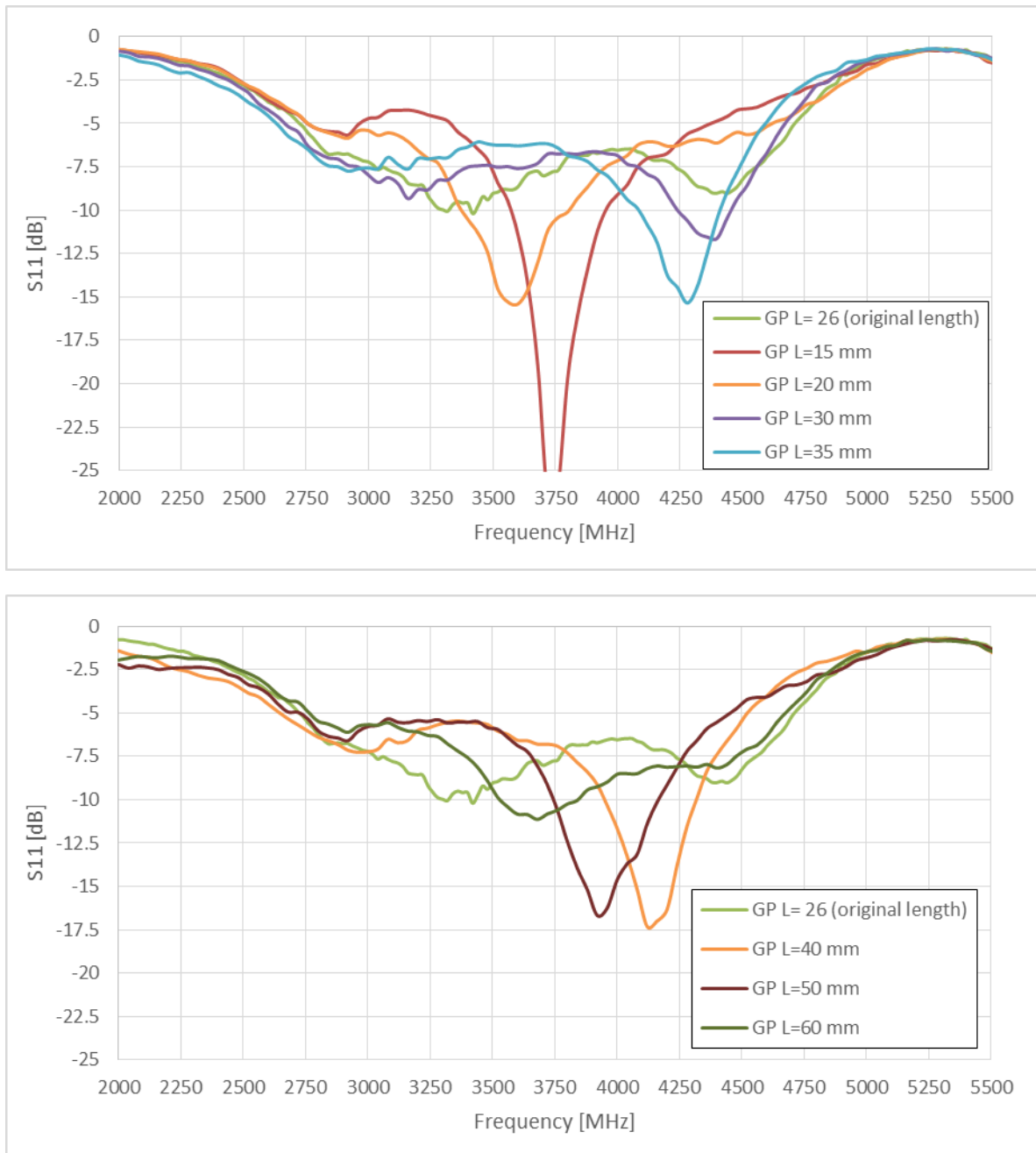

Figure 2 - Return Loss for ground plane length variation

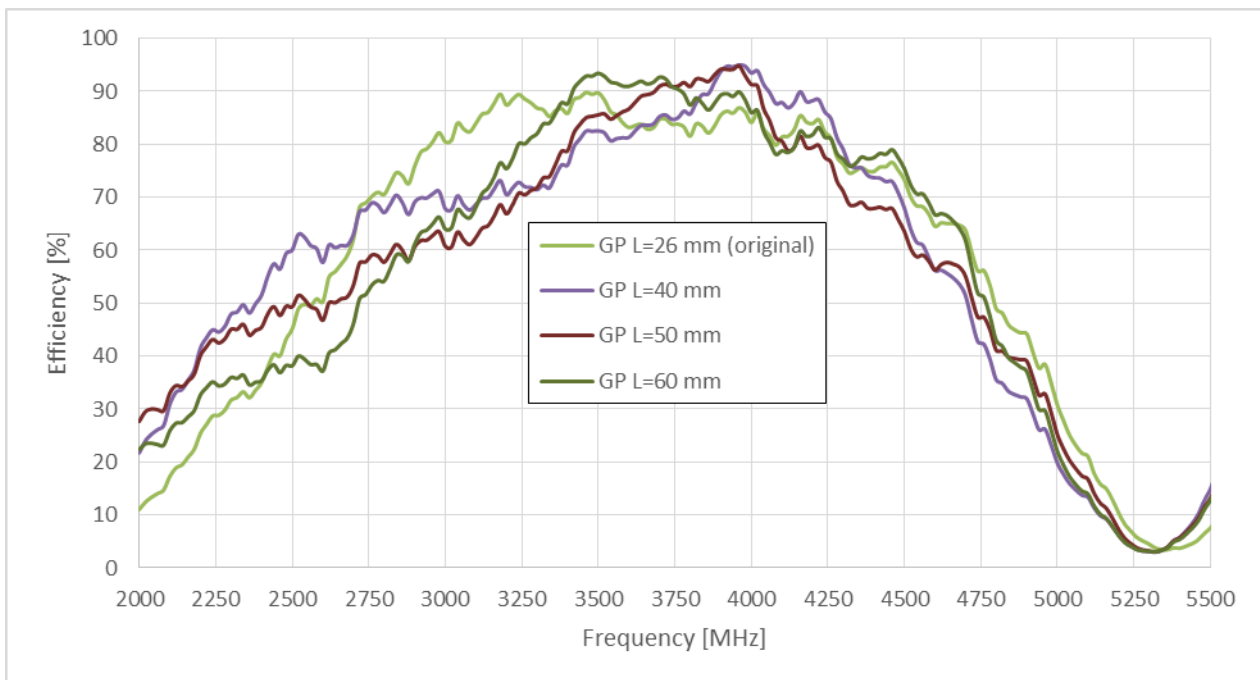
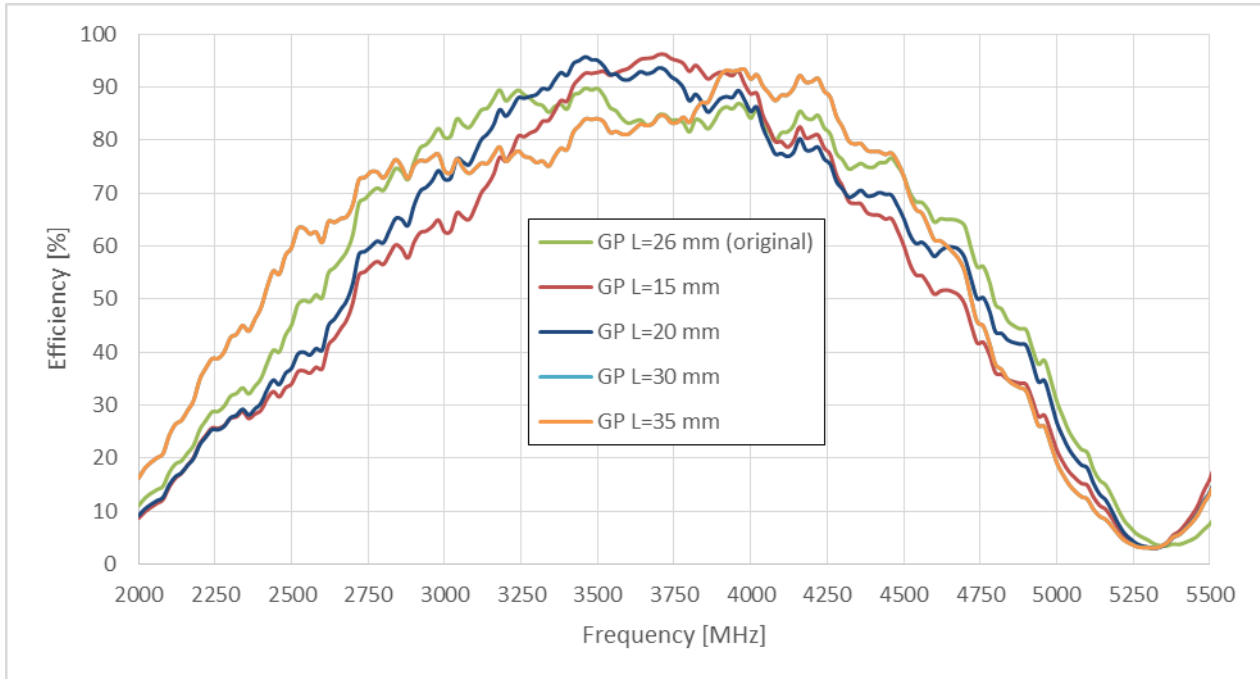

Figure 3 - Efficiency for ground plane length variation

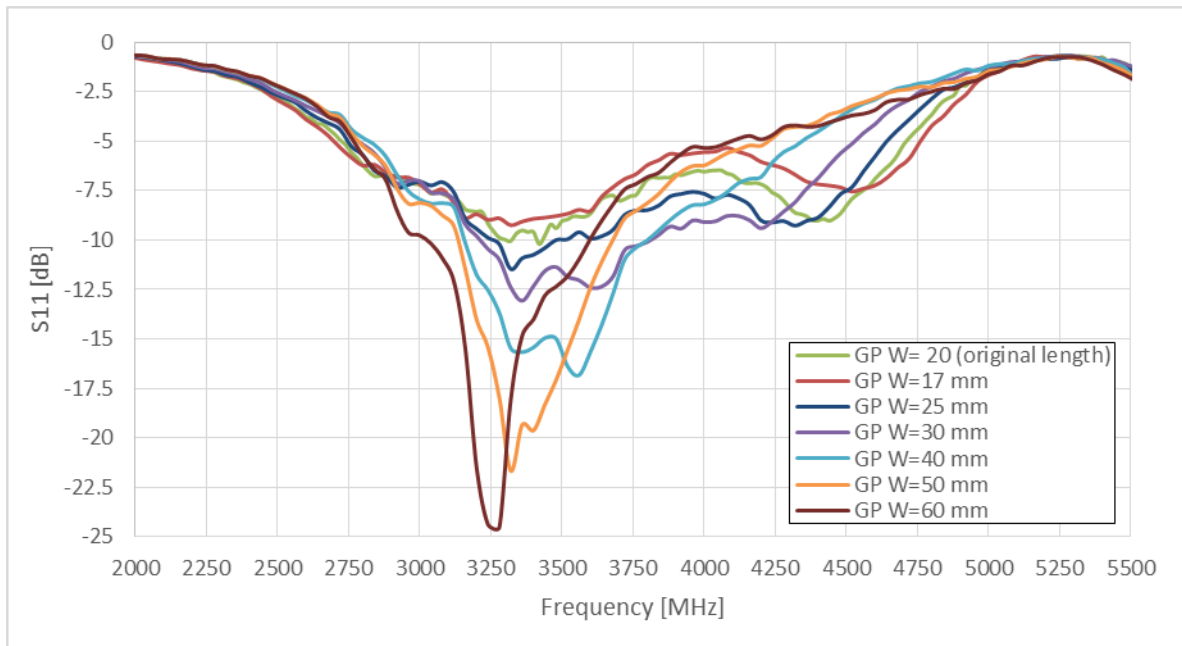

Figure 4 - Return Loss for ground plane width variation

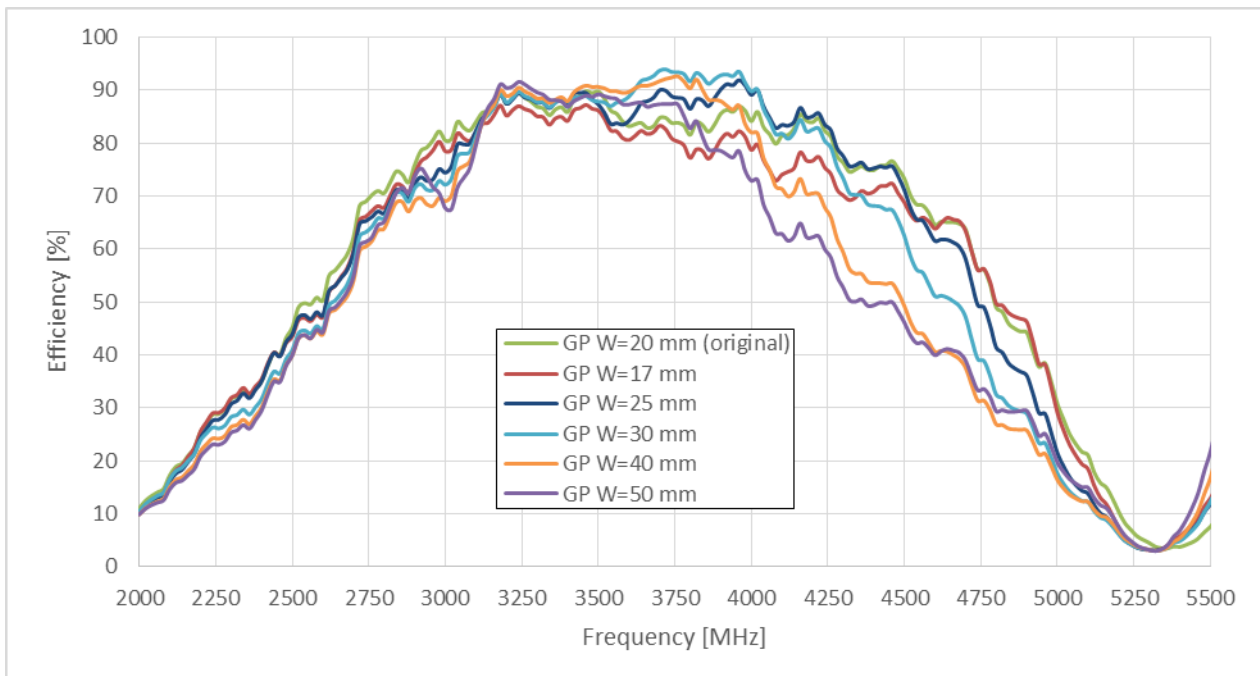

Figure 5 - Efficiency for ground plane width variation

6.2. Clearance Study

A metal clearance study is also performed. A 5*5*2mm metal component is placed on different locations around the UWC.40 antenna. Figure 13 shows the right-side positions. Equivalent left-side positions were also tested. The smallest distance was 1 mm between the antenna and the metal component.

The results show that close proximity of components on the left and right will slightly influence antenna impedance matching.

Note that the tests here specifically measure the effects of metal components unconnected to ground on the performance of UWC.40. This is not equivalent to a metal ground plane extension on the antenna sides, which should not be done.

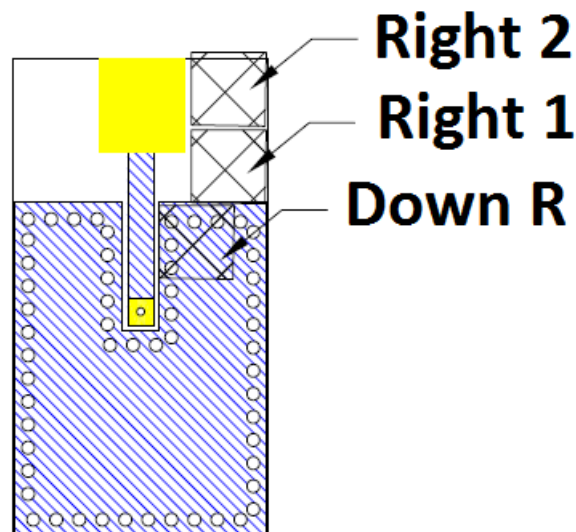

Figure 6 - Clearance study – metal component locations

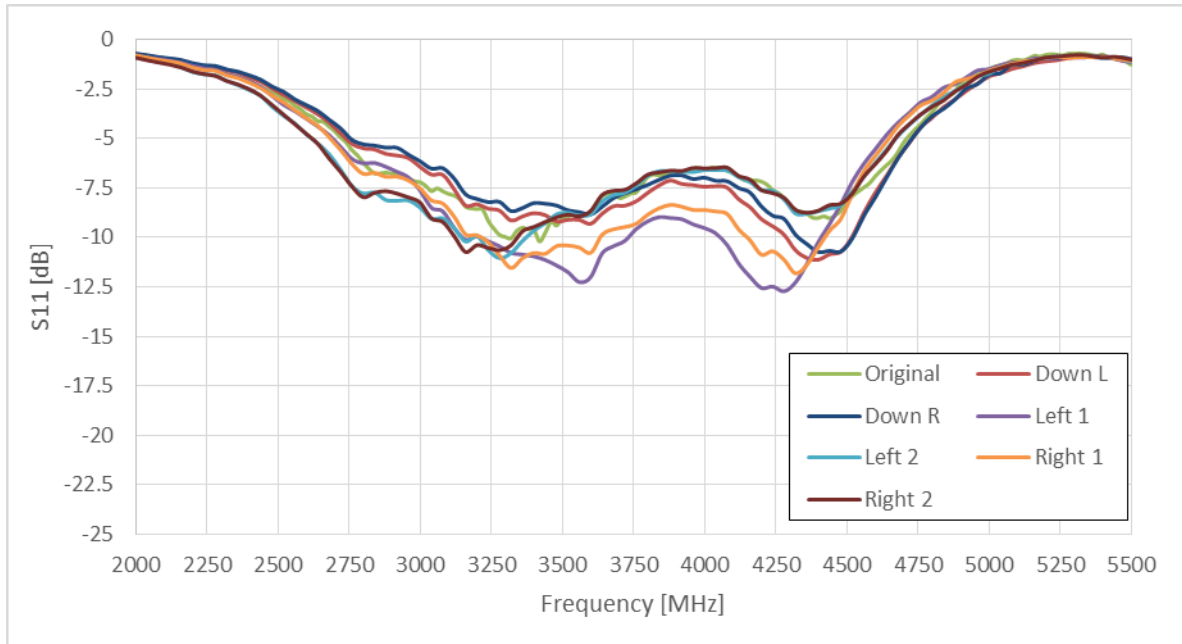

Figure 7 - Return loss for clearance study

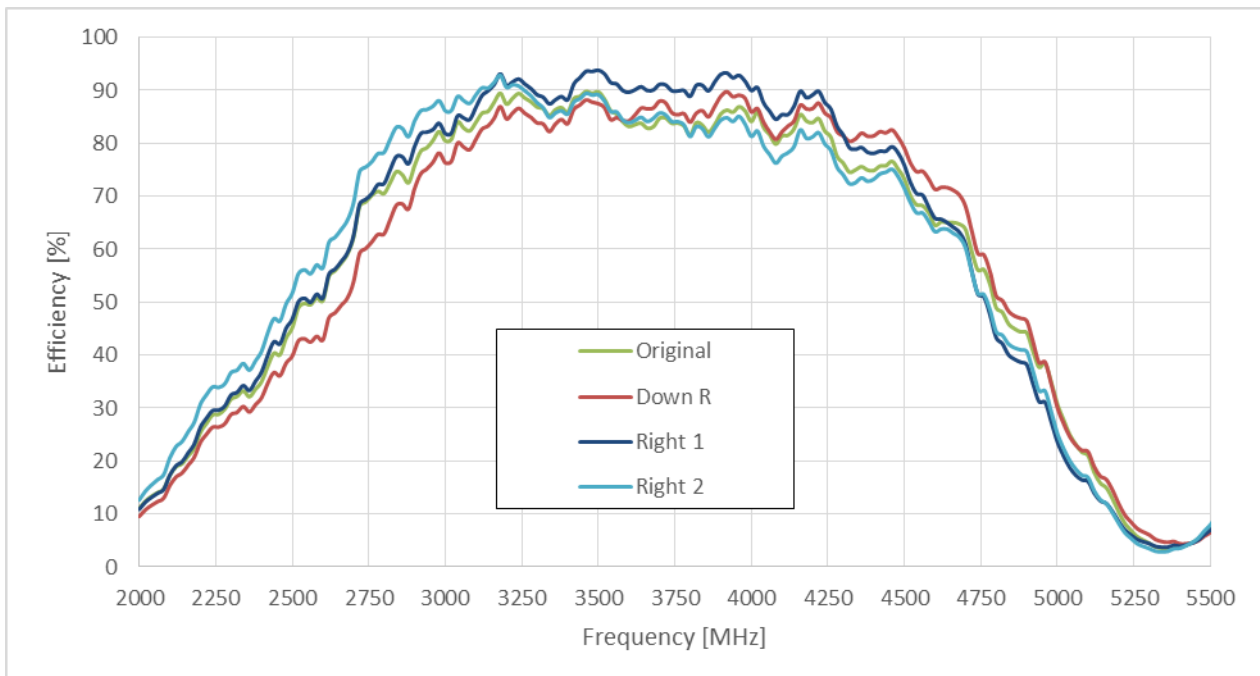

Figure 8 - Efficiency for clearance study



Taoglas makes no warranties based on the accuracy or completeness of the contents of this document and reserves the right to make changes to specifications and product descriptions at any time without notice. Taoglas reserves all rights to this document and the information contained herein.

Reproduction, use or disclosure to third parties without express permission is strictly prohibited.

© Taoglas

Компания «Океан Электроники» предлагает заключение долгосрочных отношений при поставках импортных электронных компонентов на взаимовыгодных условиях!

Наши преимущества:

- Поставка оригинальных импортных электронных компонентов напрямую с производств Америки, Европы и Азии, а так же с крупнейших складов мира;
- Широкая линейка поставок активных и пассивных импортных электронных компонентов (более 30 млн. наименований);
- Поставка сложных, дефицитных, либо снятых с производства позиций;
- Оперативные сроки поставки под заказ (от 5 рабочих дней);
- Экспресс доставка в любую точку России;
- Помощь Конструкторского Отдела и консультации квалифицированных инженеров;
- Техническая поддержка проекта, помощь в подборе аналогов, поставка прототипов;
- Поставка электронных компонентов под контролем ВП;
- Система менеджмента качества сертифицирована по Международному стандарту ISO 9001;
- При необходимости вся продукция военного и аэрокосмического назначения проходит испытания и сертификацию в лаборатории (по согласованию с заказчиком);
- Поставка специализированных компонентов военного и аэрокосмического уровня качества (Xilinx, Altera, Analog Devices, Intersil, Interpoint, Microsemi, Actel, Aeroflex, Peregrine, VPT, Syfer, Eurofarad, Texas Instruments, MS Kennedy, Miteq, Cobham, E2V, MA-COM, Hittite, Mini-Circuits, General Dynamics и др.);

Компания «Океан Электроники» является официальным дистрибьютором и эксклюзивным представителем в России одного из крупнейших производителей разъемов военного и аэрокосмического назначения «JONHON», а так же официальным дистрибьютором и эксклюзивным представителем в России производителя высокотехнологичных и надежных решений для передачи СВЧ сигналов «FORSTAR».



JONHON

«JONHON» (основан в 1970 г.)

Разъемы специального, военного и аэрокосмического назначения:

(Применяются в военной, авиационной, аэрокосмической, морской, железнодорожной, горно- и нефтедобывающей отраслях промышленности)

«FORSTAR» (основан в 1998 г.)

ВЧ соединители, коаксиальные кабели, кабельные сборки и микроволновые компоненты:

(Применяются в телекоммуникациях гражданского и специального назначения, в средствах связи, РЛС, а так же военной, авиационной и аэрокосмической отраслях промышленности).



Телефон: 8 (812) 309-75-97 (многоканальный)

Факс: 8 (812) 320-03-32

Электронная почта: ocean@oceanchips.ru

Web: <http://oceanchips.ru/>

Адрес: 198099, г. Санкт-Петербург, ул. Калинина, д. 2, корп. 4, лит. А