

LTC3615  
DUAL 4 MHz, 3A SYNCHRONOUS  
STEP-DOWN DC/DC CONVERTER

## DESCRIPTION

Demonstration circuit 1572 is a dual output regulator consisting of two constant-frequency step-down converters, based on the LTC3615 dual channel monolithic synchronous buck regulator. The DC1572 has an input voltage range of 2.25V to 5.5V, with each regulator capable of delivering up to 3A of output current. The DC1572 can operate in Burst Mode™, pulse-skip or forced continuous mode. In shutdown, the DC1572 requires less than 100  $\mu$ A total. The DC1572 is very efficient: over 90% for ei-

ther circuit. The LTC3615 comes in a 24 Pin QFN or leaded package, which each having an exposed pad on the bottom-side of the IC for better thermal performance. These features, plus a programmable operating frequency range from 400 kHz to 4 MHz (2.25 MHz switching frequency with the RT pin connected to  $SV_{IN}$ ), make the DC1572 demo board an ideal circuit for use industrial or distributed power applications. **Gerber files for this circuit are available. Call the LTC Factory.**

## QUICK START PROCEDURE

The DC1572 is easy to set up to evaluate the performance of the LTC3615. For a proper measurement equipment configuration, set up the circuit according to the diagram in Fig. 1.

**NOTE:** When measuring the input or output voltage ripple, care must be taken to avoid a long ground lead on the oscilloscope probe. Measure the input or output voltage ripple by touching the probe tip directly across the  $V_{in}$  or  $V_{out}$  and GND terminals. See the proper scope probe technique in figure 2.

Please follow the procedure outlined below for proper operation.

1. Connect the input power supply to the  $V_{in}$  and GND terminals. Connect the loads between the  $V_{out}$  and GND terminals. Refer to figure 1 for the proper measurement equipment setup.

Before proceeding to operation, insert jumper shunts XJ1 and XJ2 into the OFF positions of headers J1 and J2, shunt XJ5 into the 180° out-of-phase position of PHASE header J5, shunts XJ3 and XJ4 into the soft-start (EXT SS) positions of headers J3

and J4, shunt XJ7 into the forced continuous mode (FCM) position of MODE header JP7, shunt XJ6 into the 2.25 MHz (RT) position of the frequency (RT/SYNC) header JP6, shunts XJCOMP1 and XJCOMP2 into the external compensation (ECMP) positions of headers JITH1 and JITH2, and shunt XJP1 into the  $V_{out1}$  voltage option of choice of header JP1-4: 1.8V, 2.5V, 3.3V, or user select, and shunt XJP5 into the  $V_{out2}$  voltage option of choice of header JP5-8: 1.2V, 1.5V, 1.8V, or user select.

2. Apply 5.5V at  $V_{in}$ . Measure both  $V_{outs}$ ; they should read 0V. If desired, one can measure the shutdown supply current at this point. The supply current will be less than 100  $\mu$ A in shutdown.

3. Turn on  $V_{out1}$  and  $V_{out2}$  by shifting shunts XJ1 and XJ2 from the OFF positions to the ON positions. Both output voltages should be within a tolerance of +/- 2%.

4. Vary the input voltage from the min.  $V_{in}$  (which is dependent on  $V_{out}$ ) to 5.5V, and the load currents from 0 to 3A. Both output voltages should be within +/- 4% tolerance.

5. Set the load current of both outputs to 3A and the input voltage to 5.5V, and then measure each output ripple voltage (refer to figure 2 for proper measurement technique); they should each measure less than 30 mVAC. Also, observe the voltage waveform at either switch node of each regulator. The switching frequencies should be between 1.85 MHz and 2.65 MHz ( $T = 540$  ns and 374 ns). In all cases, both switch node waveforms should be rectangular in shape, and 180° out-of-phase with each other. Change the shunt position on header J5 to set the switch waveforms in phase with respect to each other. To operate the ckt.s in Burst Mode™ or pulse-skip mode, change the shunt in header J7. When finished, insert shunts XJ1 and XJ2 to the OFF position(s) and disconnect the power.

**Warning - If the power for the demo board is carried in long leads, the input voltage at the part could “ring”, which could affect the operation of the circuit or even exceed the maximum voltage rating of the IC. To eliminate the ringing, a small tantalum capacitor (for instance, AVX part # TPSY226M035R0200) is inserted on the pads between the input power and return terminals on the bottom of the demo board. The (greater) ESR of the tantalum will dampen the (possible) ringing voltage due to the use of long input leads. On a normal, typical PCB, with short traces, this capacitor is not needed.**

Table 1. Performance Summary ( $T_A = 25^\circ\text{C}$ )

PARAMETER	CONDITIONS	VALUE
Minimum Input Voltage		2.25V
Maximum Input Voltage		5.5V
Run	RUN Pin = GND	Shutdown
	RUN Pin = $V_{IN}$	Operating
Output Voltage $V_{OUT1}$	$V_{IN} = 2.5\text{V to } 5.5\text{V}, I_{OUT1} = 0\text{A to } 3\text{A}$	$1.8\text{V} \pm 4\%$ (1.728V – 1.872V)
	$V_{IN} = 3.3\text{V to } 5.5\text{V}, I_{OUT1} = 0\text{A to } 3\text{A}$	$2.5\text{V} \pm 4\%$ (2.4V – 2.6V)
	$V_{IN} = 3.9\text{V to } 5.5\text{V}, I_{OUT1} = 0\text{A to } 3\text{A}$	$3.3\text{V} \pm 4\%$ (3.168V – 3.432V)
Typical Output Ripple $V_{OUT1}$	$V_{IN} = 5\text{V}, I_{OUT1} = 3\text{A}$ (20 MHz BW)	< 30mV <sub>p-p</sub>
Output Regulation $V_{OUT1}$	Line	$\pm 1\%$
	Load	$\pm 1\%$
Output Voltage $V_{OUT2}$	$V_{IN} = 2.25\text{V to } 5.5\text{V}, I_{OUT2} = 0\text{A to } 3\text{A}$	$1.2\text{V} \pm 4\%$ (1.152V – 1.248V)
	$V_{IN} = 2.5\text{V to } 5.5\text{V}, I_{OUT2} = 0\text{A to } 3\text{A}$	$1.5\text{V} \pm 4\%$ (1.44V - 1.56V)
	$V_{IN} = 2.5\text{V to } 5.5\text{V}, I_{OUT2} = 0\text{A to } 3\text{A}$	$1.8\text{V} \pm 4\%$ (1.728V – 1.872V)
Typical Output Ripple $V_{OUT2}$	$V_{IN} = 5\text{V}, I_{OUT2} = 3\text{A}$ (20 MHz BW)	< 30mV <sub>p-p</sub>
Output Regulation $V_{OUT2}$	Line	$\pm 1\%$
	Load	$\pm 1\%$
Nominal Switching Frequencies	RT Pin connected to 178k	2.25 MHz
	RT Pin = $SV_{IN}$	2.25 MHz
Burst Mode™ Operation	Channel 1: $V_{IN} = 5\text{V}, V_{out1} = 3.3\text{V}$	$I_{out1} = 600$ mA
	Channel 2: $V_{IN} = 5\text{V}, V_{out2} = 1.8\text{V}$	$I_{out2} = 700$ mA
Pulse-Skip Operation	Channel 1: $V_{IN} = 5\text{V}, V_{out1} = 3.3\text{V}$	$I_{out1} = 600$ mA
	Channel 2: $V_{IN} = 5\text{V}, V_{out2} = 1.8\text{V}$	$I_{out2} = 700$ mA
Phase	Phase Pin = $SV_{IN}$	180° Out-of-Phase
	Phase Pin OPEN	90° Out-of-Phase
	Phase Pin = GND	In Phase

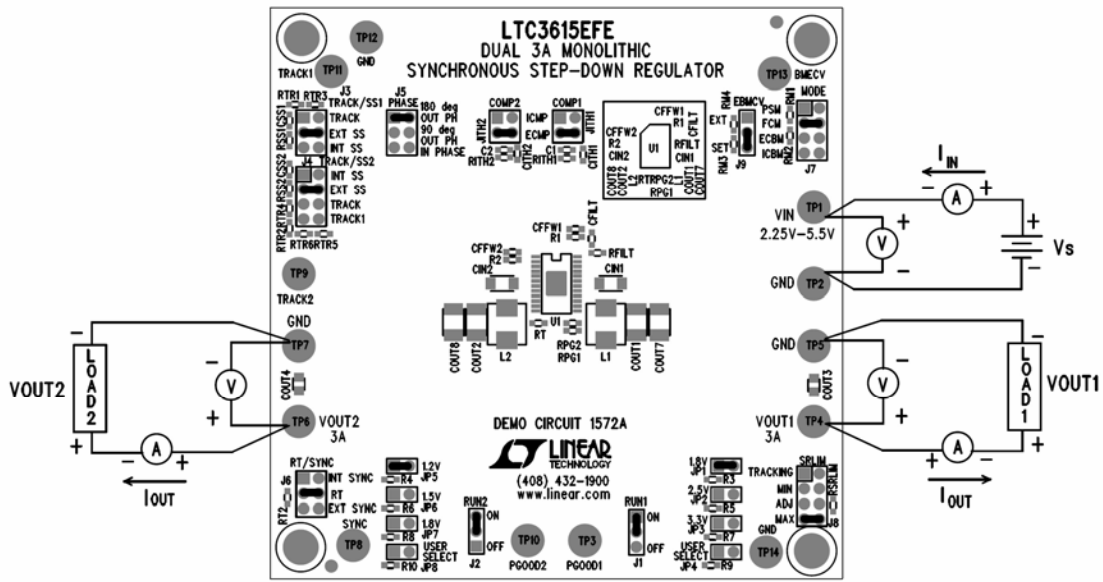

Figure 1. Proper Measurement Equipment Setup

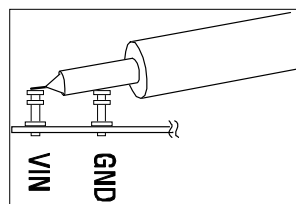

Figure 2. Measuring Input or Output Ripple

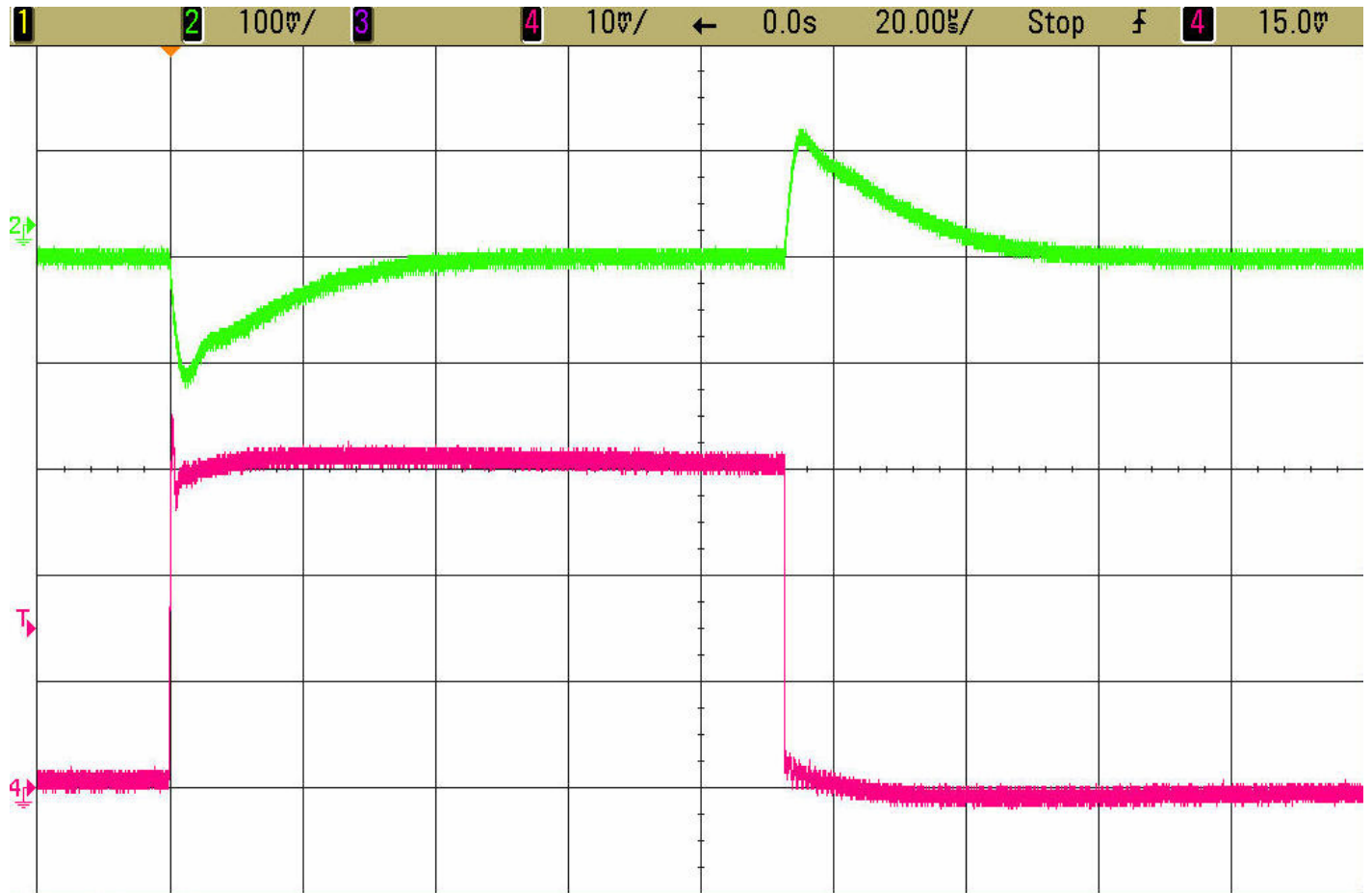

Figure 3.  $V_{OUT1}$  Load Step Response

$V_{IN} = 5V$ ,  $V_{OUT1} = 3.3V$ , 3A Load Step

Forced Continuous Mode  $F_{sw} = 2.25$  MHz  
External Compensation:  $R_{ith} = 43k$ ,  $C_{ith} = 220$  pF  
Trace 3: Output Voltage (100mV/div AC)  
Trace 4: Output Current (1A/div)

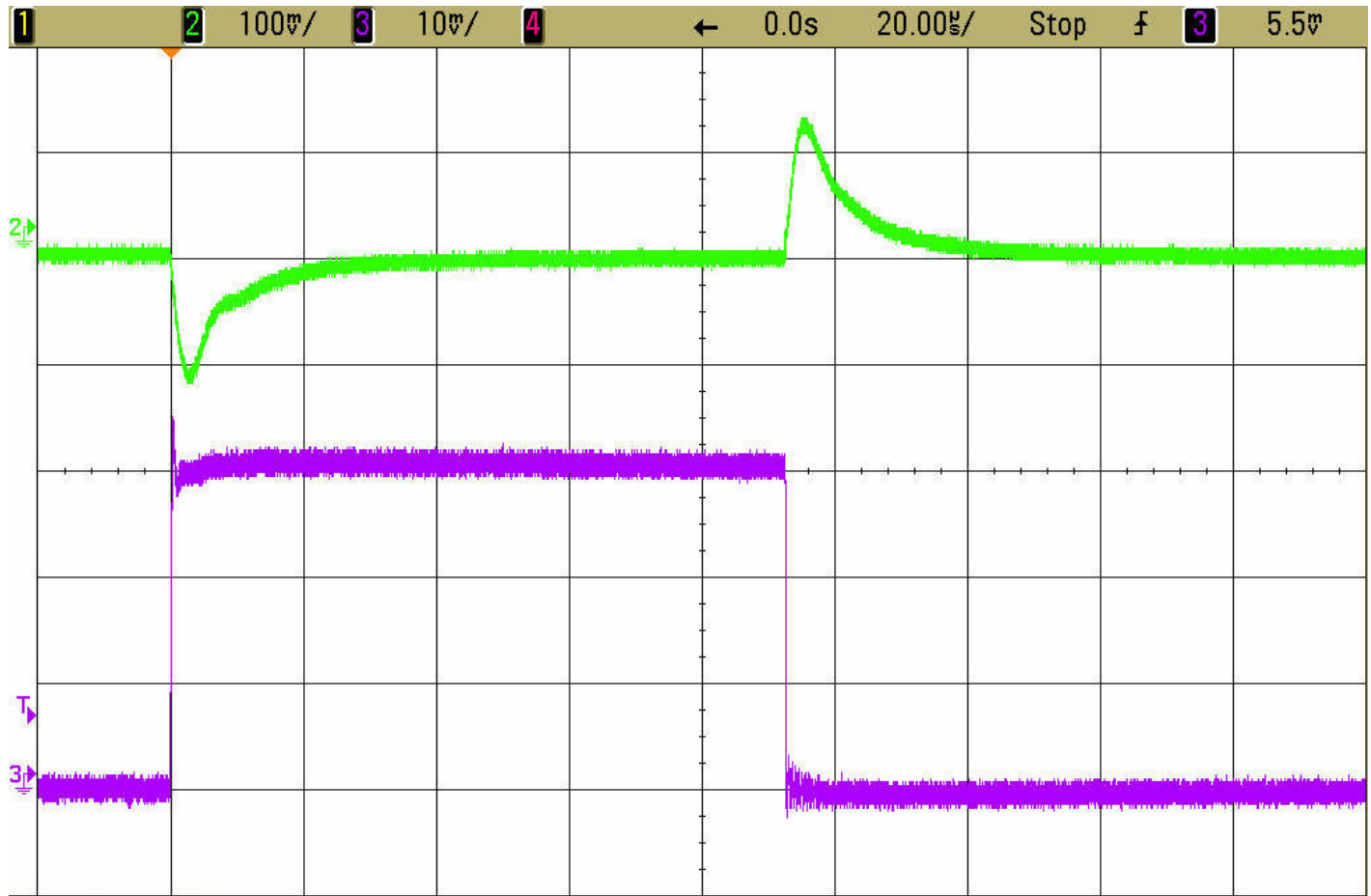

Figure 4.  $V_{OUT2}$  Load Step Response

$V_{IN} = 3.3V$ ,  $V_{OUT2} = 1.8V$ , 3A Load Step

Forced Continuous Mode  $F_{sw} = 2.25$  MHz  
External Compensation:  $R_{ith} = 43k$ ,  $C_{ith} = 220$  pF  
Trace 3: Output Voltage (100mV/div AC)  
Trace 4: Output Current (1A/div)

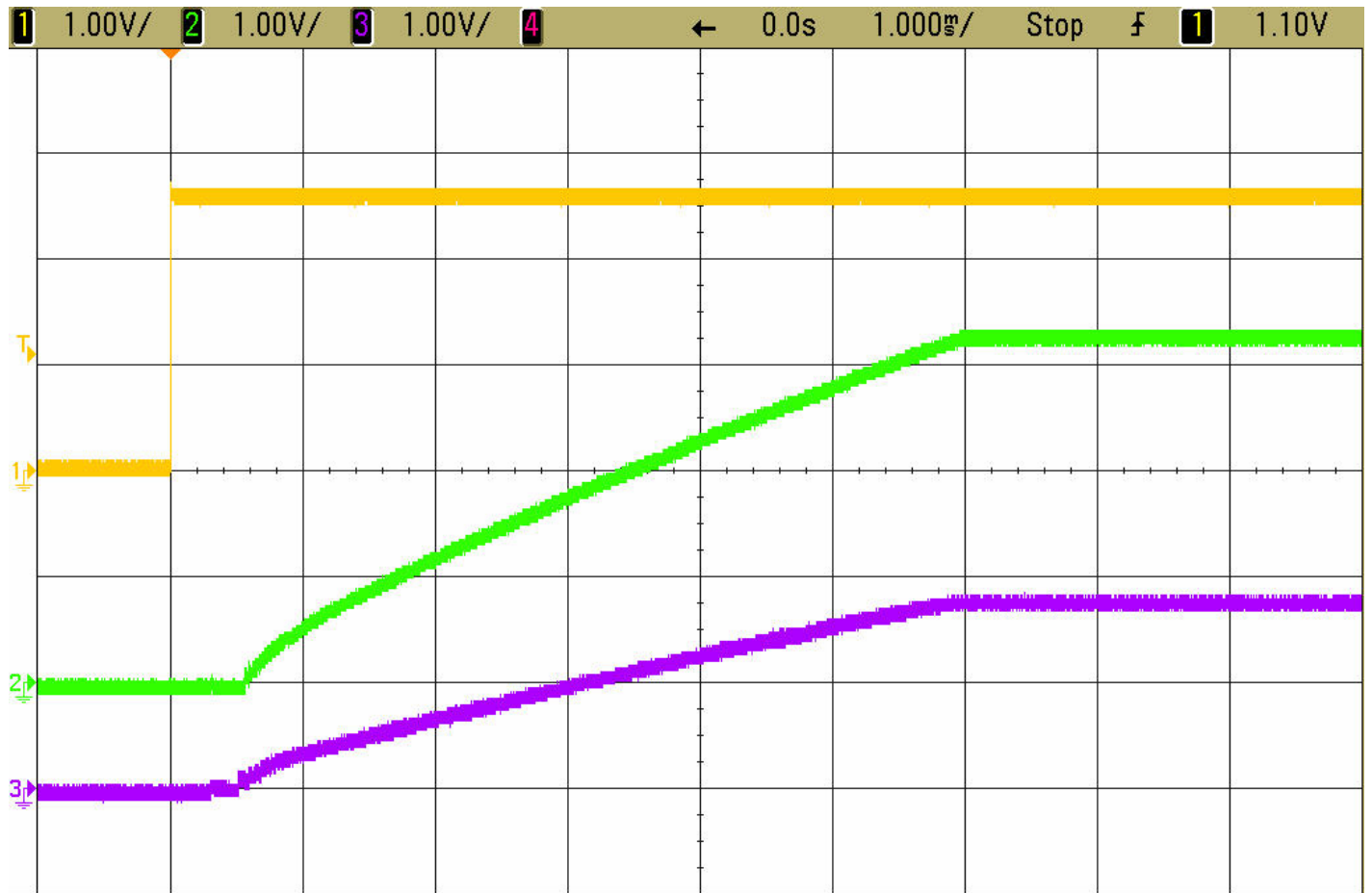

Figure 5. Start-Up Operation

$V_{IN} = 5V$ ,  $V_{OUT1} = 3.3V$ ,  $V_{OUT2} = 1.8V$ , 3A Loads

$V_{RUN} = 2.5V$

Forced Continuous Mode  $F_{SW} = 2.25$  MHz  
 External Compensation:  $R_{ith} = 43k$ ,  $C_{ith} = 220$  pF  
 Trace 3: Output Voltage (100mV/div AC)  
 Trace 4: Output Current (1A/div)

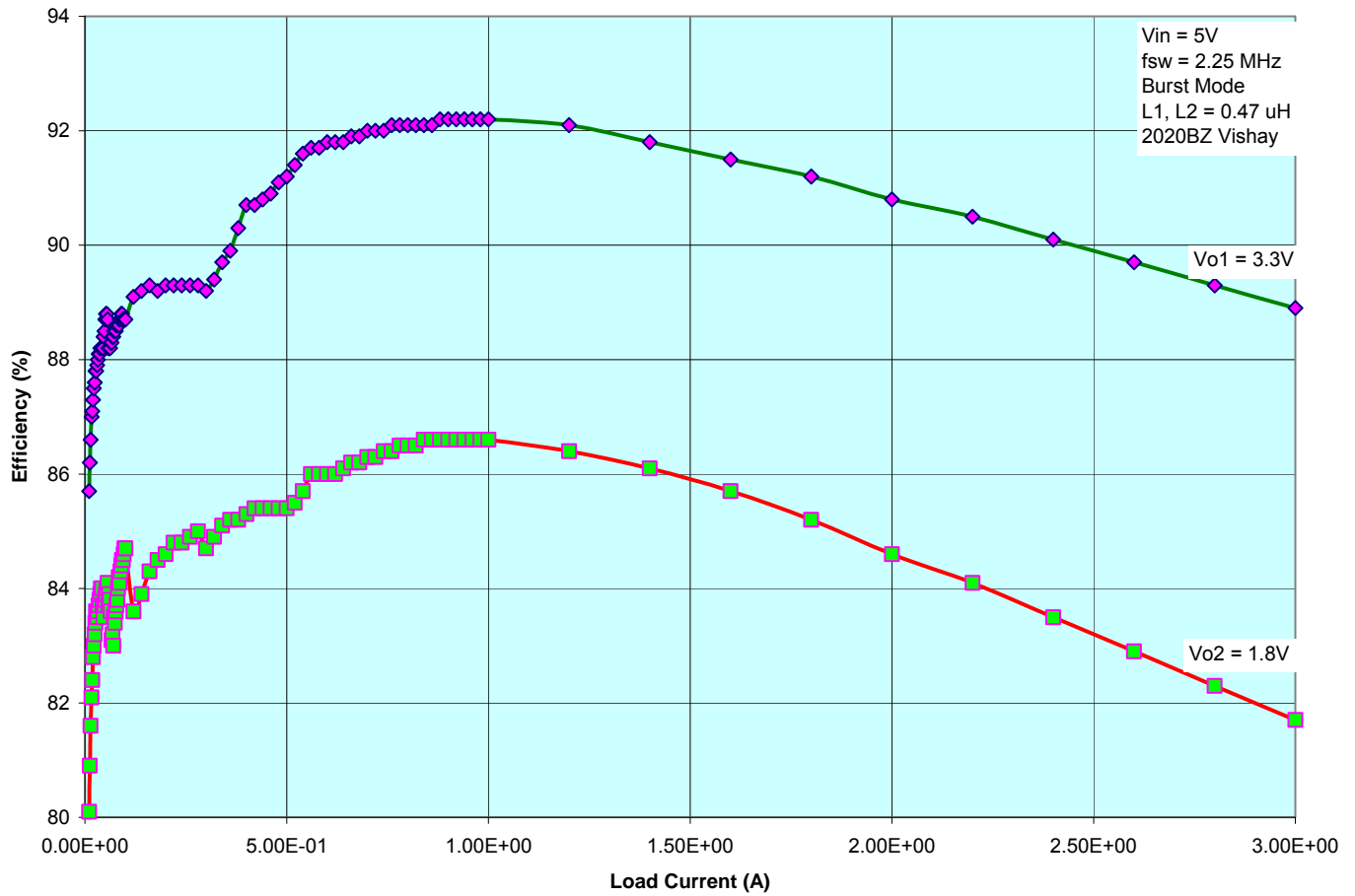
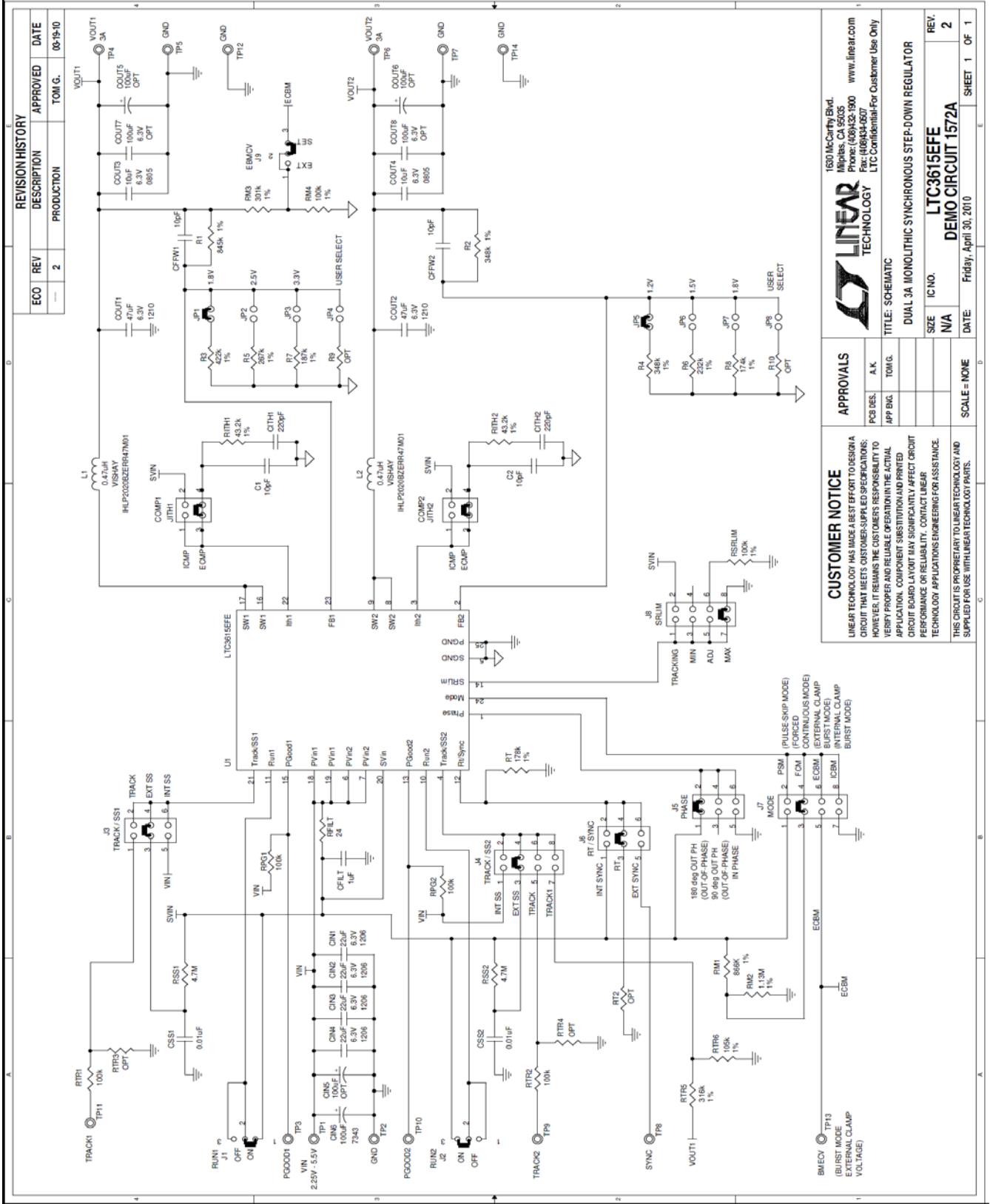

Figure 6. LTC3615 DC1572 Efficiency



ECO	REV	DESCRIPTION	APPROVED	DATE
	2	PRODUCTION	TOM G.	06-18-10

ECO	REV	DESCRIPTION	APPROVED	DATE
	2	PRODUCTION	TOM G.	06-18-10

ECO	REV	DESCRIPTION	APPROVED	DATE
	2	PRODUCTION	TOM G.	06-18-10

ECO	REV	DESCRIPTION	APPROVED	DATE
	2	PRODUCTION	TOM G.	06-18-10

**LTC3615EFE**  
**DEMO CIRCUIT 1572A**  
 DATE: Friday, April 30, 2010  
 SHEET 1 OF 1

**LINEAR TECHNOLOGY**  
 1630 McCarthy Blvd.  
 Milpitas, CA 95035  
 Phone: (408)435-1900  
 Fax: (408)435-0507  
 LTC Confidential-For Customer Use Only

**CUSTOMER NOTICE**  
 LINEAR TECHNOLOGY HAS MADE A BEST EFFORT TO DESIGN A CIRCUIT THAT MEETS CUSTOMER-SUPPLIED SPECIFICATIONS; HOWEVER, IT REMAINS THE CUSTOMER'S RESPONSIBILITY TO VERIFY PROPER AND RELIABLE OPERATION IN THE ACTUAL APPLICATION. COMPONENT SUBSTITUTION AND PRINTED CIRCUIT BOARD LAYOUT MAY SIGNIFICANTLY AFFECT CIRCUIT PERFORMANCE OR RELIABILITY. CONTACT LINEAR TECHNOLOGY APPLICATIONS ENGINEERING FOR ASSISTANCE.  
 THIS CIRCUIT IS PROPRIETARY TO LINEAR TECHNOLOGY AND SUPPLIED FOR USE WITH LINEAR TECHNOLOGY PARTS.

**APPROVALS**  
 PCB DES. A.K.  
 APP ENG. TOM.G.  
 TITLE: SCHEMATIC  
 DUAL 3A MONOLITHIC SYNCHRONOUS STEP-DOWN REGULATOR  
 SIZE IC NO. N/A  
 SCALE = NONE  
 DATE: Friday, April 30, 2010



Компания «Океан Электроники» предлагает заключение долгосрочных отношений при поставках импортных электронных компонентов на взаимовыгодных условиях!

Наши преимущества:

- Поставка оригинальных импортных электронных компонентов напрямую с производств Америки, Европы и Азии, а так же с крупнейших складов мира;
- Широкая линейка поставок активных и пассивных импортных электронных компонентов (более 30 млн. наименований);
- Поставка сложных, дефицитных, либо снятых с производства позиций;
- Оперативные сроки поставки под заказ (от 5 рабочих дней);
- Экспресс доставка в любую точку России;
- Помощь Конструкторского Отдела и консультации квалифицированных инженеров;
- Техническая поддержка проекта, помощь в подборе аналогов, поставка прототипов;
- Поставка электронных компонентов под контролем ВП;
- Система менеджмента качества сертифицирована по Международному стандарту ISO 9001;
- При необходимости вся продукция военного и аэрокосмического назначения проходит испытания и сертификацию в лаборатории (по согласованию с заказчиком);
- Поставка специализированных компонентов военного и аэрокосмического уровня качества (Xilinx, Altera, Analog Devices, Intersil, Interpoint, Microsemi, Actel, Aeroflex, Peregrine, VPT, Syfer, Eurofarad, Texas Instruments, MS Kennedy, Miteq, Cobham, E2V, MA-COM, Hittite, Mini-Circuits, General Dynamics и др.);

Компания «Океан Электроники» является официальным дистрибьютором и эксклюзивным представителем в России одного из крупнейших производителей разъемов военного и аэрокосмического назначения «JONHON», а так же официальным дистрибьютором и эксклюзивным представителем в России производителя высокотехнологичных и надежных решений для передачи СВЧ сигналов «FORSTAR».



## JONHON

«JONHON» (основан в 1970 г.)

Разъемы специального, военного и аэрокосмического назначения:

(Применяются в военной, авиационной, аэрокосмической, морской, железнодорожной, горно- и нефтедобывающей отраслях промышленности)

«FORSTAR» (основан в 1998 г.)

ВЧ соединители, коаксиальные кабели, кабельные сборки и микроволновые компоненты:

(Применяются в телекоммуникациях гражданского и специального назначения, в средствах связи, РЛС, а так же военной, авиационной и аэрокосмической отраслях промышленности).



Телефон: 8 (812) 309-75-97 (многоканальный)

Факс: 8 (812) 320-03-32

Электронная почта: [ocean@oceanchips.ru](mailto:ocean@oceanchips.ru)

Web: <http://oceanchips.ru/>

Адрес: 198099, г. Санкт-Петербург, ул. Калинина, д. 2, корп. 4, лит. А