

# Heater Element Burnout Detector K2CU

## Accurate Detection of Heater Element Burnout Regardless of Heater Capacities

- Accurately detects a burned heater element or elements incorporated by a molding machine or packing machine and outputs an alarm signal.
- Precisely singles out the burned element even if one heater element among several heater elements has been burned out.
- Applicable to small- to large-capacity heater elements.
- All K2CU-F large-capacity, built-in current transformer models work with both single-phase and three-phase heaters.
- Voltage fluctuation compensation function eliminates false alarms due to variations in the supply voltage.



## Model Number Structure

### Model Number Legend

**K2CU-□□□-□□**  
 1 2 3 4 5 6

#### 1. Heater Element Burnout Detector

#### 2. Operation

- F: Large-capacity, built-in Current Transformer model
- P: Small-capacity plug-in model

#### 3. Operating Current Range

- 0.5: 0.25 to 0.5 A
- 1: 0.5 to 1 A
- 2: 1 to 2 A
- 4: 2 to 4 A
- 10: 4 to 10 A
- 20: 8 to 20 A
- 40: 16 to 40 A
- 80: 32 to 80 A

#### 4. Voltage Compensation

- None: Not provided
- A: Provided

#### 5. Control Power Supply Voltage

- A: 100/200 VAC
- B: 110/220 VAC
- C: 100 VAC
- D: 110 VAC
- E: 200 VAC
- F: 220 VAC

#### 6. Gate Input

- None: Not provided
- GS: Provided

## Ordering Information

### K2CU-F□□A-□GS Model with Gate Input Terminals

Control supply voltage		Operating current			
		4 to 10 A	8 to 20 A	16 to 40 A	32 to 80 A
100 VAC	With voltage fluctuation compensation	K2CU-F10A-CGS	K2CU-F20A-CGS	K2CU-F40A-CGS	K2CU-F80A-CGS
110 VAC		K2CU-F10A-DGS	K2CU-F20A-DGS	K2CU-F40A-DGS	K2CU-F80A-DGS
200 VAC		K2CU-F10A-EGS	K2CU-F20A-EGS	K2CU-F40A-EGS	K2CU-F80A-EGS
220 VAC		K2CU-F10A-FGS	K2CU-F20A-FGS	K2CU-F40A-FGS	K2CU-F80A-FGS

**Note:** A model with a gate input terminal is required to combine the K2CU with a temperature controller that uses PID control for temperature control of a heater. To do so, use a temperature controller with a voltage output.

## K2CU-F Large-capacity, Built-in Current Transformer Models

Control supply voltage		Operating current			
		4 to 10 A	8 to 20 A	16 to 40 A	32 to 80 A
100 VAC	With voltage fluctuation compensation	K2CU-F10A-C	K2CU-F20A-C	K2CU-F40A-C	K2CU-F80A-C
110 VAC		K2CU-F10A-D	K2CU-F20A-D	K2CU-F40A-D	K2CU-F80A-D
200 VAC		K2CU-F10A-E	K2CU-F20A-E	K2CU-F40A-E	K2CU-F80A-E
220 VAC		K2CU-F10A-F	K2CU-F20A-F	K2CU-F40A-F	K2CU-F80A-F

## K2CU-P Small-capacity, Plug-in Models

Control supply voltage		Operating current			
		0.25 to 0.5 A	0.5 to 1 A	1 to 2 A	2 to 4 A
100/ 200 VAC	With voltage fluctuation compensation	K2CU-P0.5A-A	K2CU-P1A-A	K2CU-P2A-A	K2CU-P4A-A
	Without voltage fluctuation compensation	---	K2CU-P1-A	K2CU-P2-A	K2CU-P4-A
110/ 220 VAC	With voltage fluctuation compensation	K2CU-P0.5A-B	K2CU-P1A-B	K2CU-P2A-B	K2CU-P4A-B
	Without voltage fluctuation compensation	---	K2CU-P1-B	K2CU-P2-B	K2CU-P4-B

## Specifications

### ■ Ratings

Item	K2CU-F	K2CU-P
Control supply voltage	100, 110, 200, 220 VAC	100/200, 110/220 VAC
Rated frequency	50/60 Hz	
Carry current	1.25 times as large as each model's maximum operating current	2.5 A for K2CU-P0.5A-A/-B; 5 A
Operating voltage range	85% to 110% of control supply voltage	
Voltage fluctuation compensation range	85% to 110% of control supply voltage	85% to 110% of control supply voltage (applicable only on models with voltage fluctuation compensation)
Operating current	4 to 10 A, 8 to 20 A, 16 to 40 A, 32 to 80 A (continuously variable)	0.25 to 0.5 A, 0.5 to 1 A, 1 to 2 A, 2 to 4 A (continuously variable)
Releasing current	105% max. of operating current	110% max. of operating current
Operate time	0.5 s max. (when current changes from 150% to 0%)	
Gate input voltage range (for models with gate input terminals)	5 to 30 VDC	---
Control output	2 A at 220 VAC, SPDT ( $\cos\phi = 0.4$ )	
Power consumption	Input: 0.5 VA max. Power supply: 5 VA max.	Input: 1 VA max. Power supply: 4 VA max.

### ■ Characteristics

Setting accuracy	$\pm 7\%$ max.
Repeat accuracy	$\pm 3\%$ max.
Influence of temperature	$\pm 10\%$ max. (at $20^\circ\text{C} \pm 30^\circ\text{C}$ )
Influence of voltage	Models without voltage fluctuation compensation: $\pm 3\%$ max. of the value measured at the control supply voltage, on condition that the voltage fluctuation is 85% to 110% of the control supply voltage Models with voltage fluctuation compensation: $\pm 5\%$ max. of the logical value, on condition that the voltage fluctuation is 85% to 110% of the control supply voltage. (see note)
Influence of frequency	$\pm 3\%$ max. (at $\pm 5\%$ of rated frequency)
Insulation resistance	10 M $\Omega$ min. (at 500 VDC) between electric circuits and mounting panel
Dielectric strength	2,000 VAC, 50/60 Hz for 1 min between electric circuits and mounting panel
Overcurrent	20 times of max. set value of operating current for 2 s
Vibration resistance	Destruction: 16.7 Hz, 1-mm double amplitude for 10 min each in X, Y, and Z directions
Shock resistance	Destruction: 98 m/s <sup>2</sup> (approx. 10G)
Ambient temperature	Operating: $-10^\circ\text{C}$ to $55^\circ\text{C}$ (with no icing)
Ambient humidity	Operating: 45% to 85%
Weight	K2CU-F: approx. 390 g; K2CU-P: approx. 300 g

Note: The logical value is an operating value within a range of 0.85 to 1.1 with a voltage fluctuation of 85% to 110%, based on the value at the control supply voltage measured as 1.

# Operation

## K2CU-F□□A-□GS Series

When power is supplied to the heater (when the SSR is ON), a current flows through the wires to the heater elements. At the same time, a voltage is imposed on the gate circuit and the K2CU-F□□A-□GS begins monitoring the current flowing through the heater wires.

The current flowing to the heater wires is detected by the detector sections through each Current Transformer (CT) incorporated by the K2CU-F□□A-□GS.

The current signals transmitted by the two CTs are sent to the current-voltage converters, smoothing circuits, and comparators as shown in the diagram.

The signal generated by the reference voltage generator is sent to the setting circuit to provide a reference value. The reference value is sent to the comparators. Each comparator compares its heater element current input and the reference value. If the input is lower than the reference value, a signal is sent to the output circuit.

There are two detector sections operating independently. If either of the input signals from the CTs is lower than the reference value, the output relay and alarm indicator will be activated.

The K2CU-F□□A-□GS incorporates a voltage fluctuation compensation function which automatically corrects the reference value if the supply voltage fluctuates.

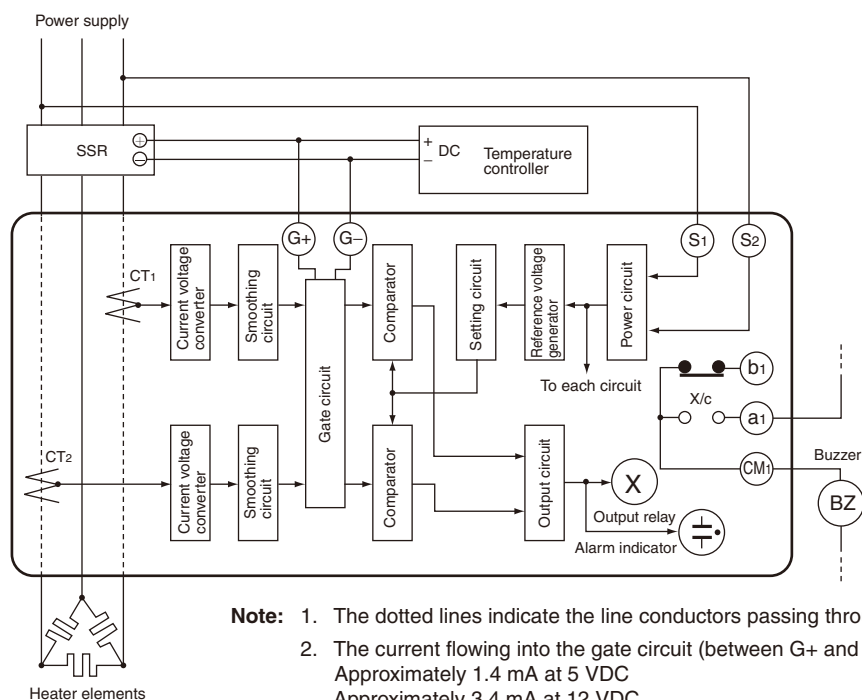

- Note:**
1. The dotted lines indicate the line conductors passing through the windows of the current transformers.
  2. The current flowing into the gate circuit (between G+ and G-) is as follows:  
 Approximately 1.4 mA at 5 VDC  
 Approximately 3.4 mA at 12 VDC  
 Approximately 6.7 mA at 24 VDC
  3. When using a K2CU which has the model number suffix "GS" (a model that incorporates gate input terminals), the control output of the temperature controller must be a voltage output type.

## K2CU-F Series

When power is supplied to the heater (when the contactor is ON), a current flows through the wires to the heater elements. At the same time, a voltage is imposed on the power circuit of the K2CU-F.

The current flowing to the heater wires is detected by the detector sections through each Current Transformer (CT) incorporated by the K2CU-F.

The current signals transmitted by the two CTs are sent to the current-voltage converters, smoothing circuits, and comparators as shown in the diagram.

The signal generated by the reference voltage generator is sent to the setting circuit to provide a reference value. The reference value is sent to the comparators. Each comparator compares its heater element current input and the reference value. If the input is lower than the reference value, a signal is sent to the output circuit.

There are two detector sections operating independently. If either of the input signals from the CTs is lower than the reference value, the output relay and alarm indicator will be activated.

The K2CU-F incorporates a voltage fluctuation compensation function which automatically corrects the reference value if the supply voltage fluctuates.



**Note:** The dotted lines indicate the line conductors passing through the windows of the current transformers.

## K2CU-P Series

The K2CU-P operates basically in the same way as the K2CU-F.

The comparator compares external current signals and the reference value and outputs the result of the comparison to the output circuit.

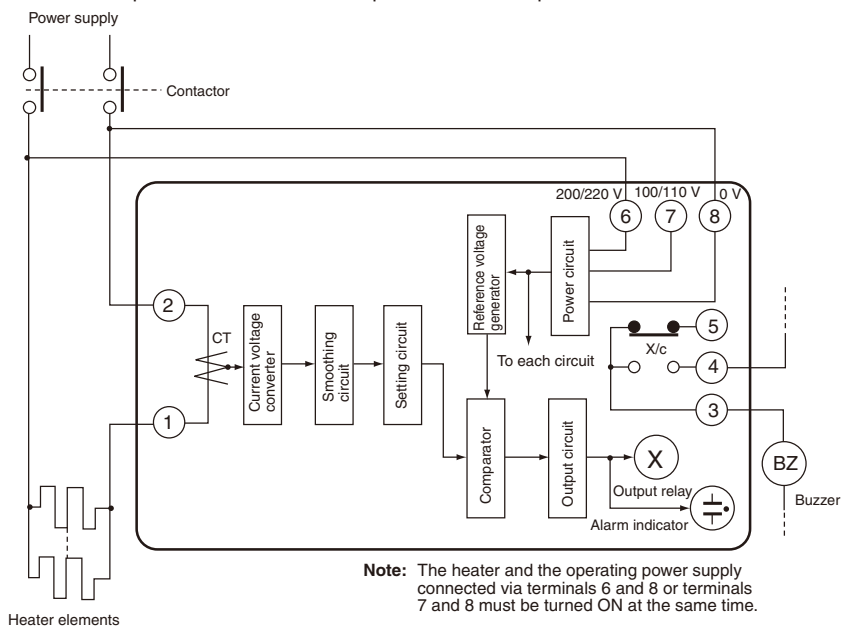

**Note:** The heater and the operating power supply connected via terminals 6 and 8 or terminals 7 and 8 must be turned ON at the same time.

## Setting of Operating Current

Use the potentiometer on the front panel to set the operating current.

Rotate the knob to set the desired current value at which the Heater Burnout Detector should operate. Do not exceed the maximum and minimum positions.

The K2CU-F's scale is divided into 12 graduations including sub-graduations and the K2CU-P's scale is divided into 5 graduations.

The knobs of the K2CU-F and K2CU-P as shown in the illustrations are set to 32 A and 0.7 A respectively.

The set operating current is defined as the mean value of the heater current under normal operating conditions and the heater current under a burnout or abnormal condition.

$$\text{Set value} = \frac{\text{Normal current} + \text{abnormal current}}{2}$$



Knob



Red point (indicates the set value)

## Heater Connection and Current

The following table shows the different connections possible. The formula under each illustration indicates the electrical current value of the heater elements under normal and abnormal conditions.

Phase		Normal condition	Abnormal condition	
Single phase				
Three phase	Delta network			
	Star network			
	V network			

**Note:** Values in this table are correct when a 200 VAC, 1 kW heater is used on a single-phase or three-phase current.

## ■ Operation Check

### K2CU-F□□A-□GS

The operation of the heater burnout detector can be easily checked as follows:

#### In a Single-phase Circuit

Set the operating current to be 0.6 to 0.55 times the heater current.

Close the SW<sub>2</sub> with switch SW<sub>1</sub> turned on. Confirm that the alarm indicator remains off.

Turn off SW<sub>1</sub> and confirm that the alarm indicator comes on, and that the output relay operates.

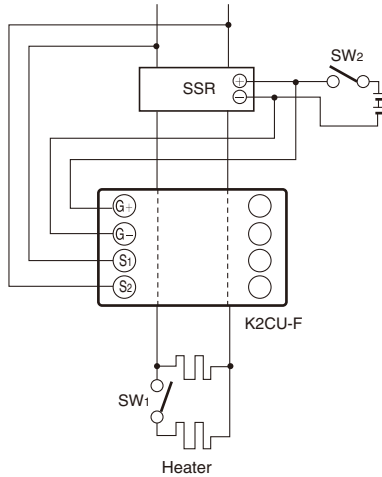

#### In a Three-phase, Delta Network

Set the operating current to be 0.6 times the heater current.

Close the SW<sub>3</sub> with switches SW<sub>1</sub> and SW<sub>2</sub> turned on. Confirm that the alarm indicator remains off.

Turn off SW<sub>2</sub> and confirm that the alarm indicator comes on, and that the output relay operates.

Turn on SW<sub>1</sub> set the operating current to be 0.9 times the heater current, and confirm that the alarm indicator goes off and the output relay releases.

Turn off SW<sub>1</sub> and confirm that the alarm indicator comes on, and that the output relay operates.

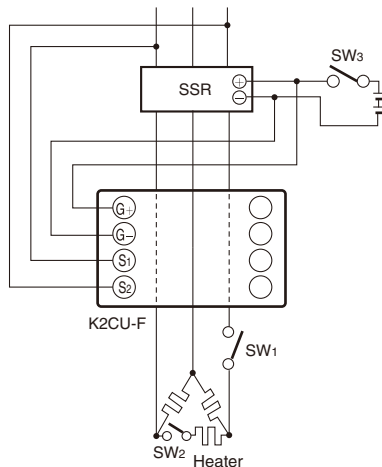

#### In a Three-phase, Star Network

Set the operating current to be 0.9 times the heater current.

Close the SW<sub>2</sub> with switch SW<sub>1</sub> turned on. Confirm that the alarm indicator remains off.

Turn off SW<sub>1</sub> and confirm that the alarm indicator comes on, and that the output relay operates.

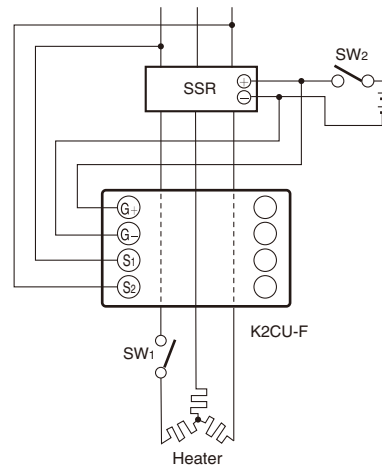

## In a Three-phase, V Network 1

Set the operating current to be 0.3 to 0.35 times the heater current.  
 Close the SW<sub>2</sub> with switch SW<sub>1</sub> turned on. Confirm that the alarm indicator remains off.  
 Turn off SW<sub>1</sub> and confirm that the alarm indicator comes on, and that the output relay operates.



## In a Three-phase, V Network 2

Set the operating current to be 0.6 times the heater current (of the phase connected between terminals 1 and 2, or the one passed through the window of the window-type Current Transformer of the heater burnout detector).  
 Close the SW<sub>2</sub> with switch SW<sub>1</sub> turned on. Confirm that the alarm indicator remains off.  
 Turn off SW<sub>1</sub> and confirm that the alarm indicator comes on, and that the output relay operates.



## K2CU-F, K2CU-P

The operation of the heater burnout detector can be easily checked as follows:

### In a Single-phase Circuit

Set the operating current to be 0.55 to 0.6 times the heater current.  
 Close the contactor with switch SW<sub>1</sub> turned on. Confirm that the alarm indicator remains off.  
 Turn off SW<sub>1</sub> and confirm that the alarm indicator comes on, and that the output relay operates.



## In a Three-phase, Delta Network

Set the operating current to be 0.6 times the heater current.

Close the contactor with switches SW<sub>1</sub> and SW<sub>2</sub> turned on. Confirm that the alarm indicator remains off.

Turn off SW<sub>2</sub> and confirm that the alarm indicator comes on, and that the output relay operates.

Turn on SW<sub>1</sub> set the operating current to be 0.9 times the heater current, and confirm that the alarm indicator goes off and the output relay releases.

Turn off SW<sub>1</sub> and confirm that the alarm indicator comes on, and that the output relay operates.

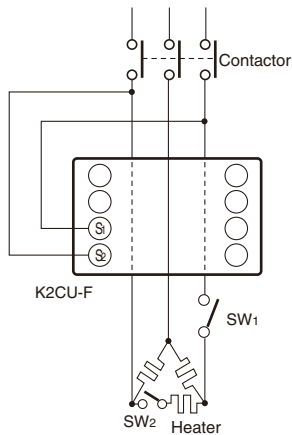

## In a Three-phase, Star Network

Set the operating current to be 0.9 times the heater current.

Close the contactor with switch SW<sub>1</sub> turned on. Confirm that the alarm indicator remains off.

Turn off SW<sub>1</sub> and confirm that the alarm indicator comes on, and that the output relay operates.

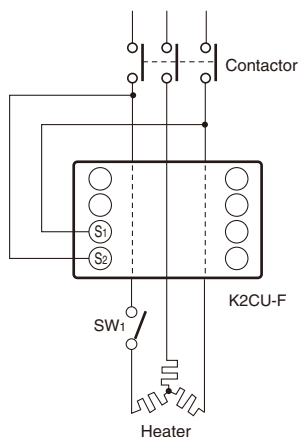

## In a Three-phase, V Network 1

Set the operating current to be 0.3 to 0.35 times the heater current.

Close the contactor with switch SW<sub>1</sub> turned on. Confirm that the alarm indicator remains off.

Turn off SW<sub>1</sub> and confirm that the alarm indicator comes on, and that the output relay operates.

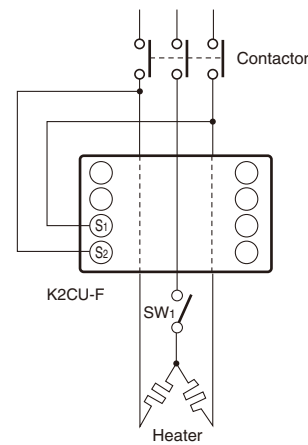

## In a Three-phase, V Network 2

Set the operating current to be 0.6 times the heater current (of the phase connected between terminals 1 and 2, or the one passed through the window of the window-type Current Transformer of the heater burnout detector).

Close the contactor with switch SW<sub>1</sub> turned on. Confirm that the alarm indicator remains off.

Turn off SW<sub>1</sub> and confirm that the alarm indicator comes on, and that the output relay operates.

K2CU-P

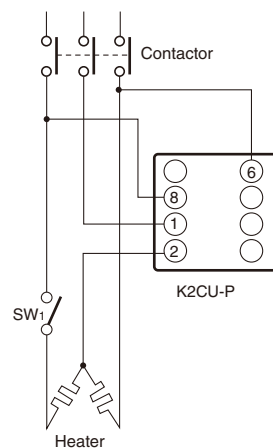

K2CU-F

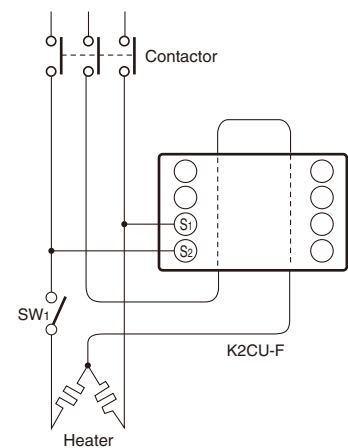



## Test Circuit

To check the operation in detail, use the following circuit.

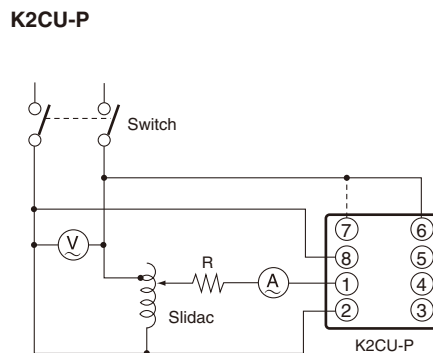

**Note:** Determine the value of R according to the specifications of the K2CU to be used. The dotted line indicates the connection at a supply voltage of 100 or 110 VAC.

## Dimensions

**Note:** All units are in millimeters unless otherwise indicated.

### K2CU-F

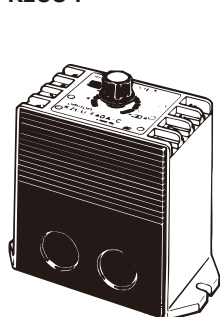

### Mounting Holes



- Note:**
1. Install the K2CU-F on a flat surface.
  2. When solderless terminal lugs are desired, use ones having an outer diameter of 6.5 mm maximum.

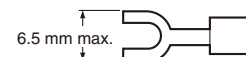

### K2CU-P

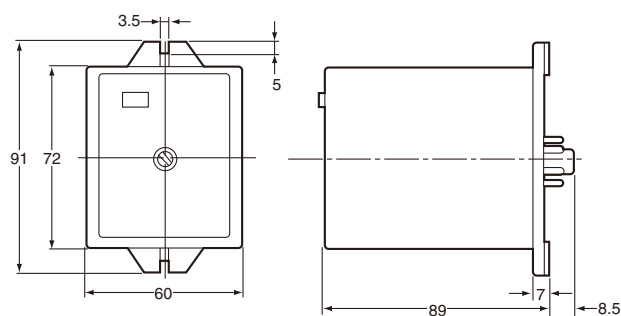
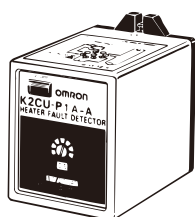

### Connecting Socket

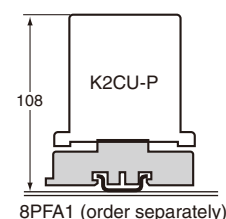

# Installation

## External Connections

### K2CU-F□□A-□GS

#### Single-phase Heater



#### Three-phase Heater

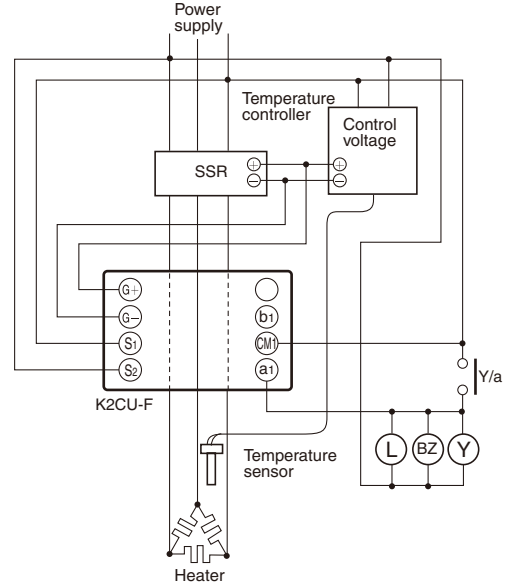

### K2CU-F

#### Single-phase Heater



#### Three-phase Heater

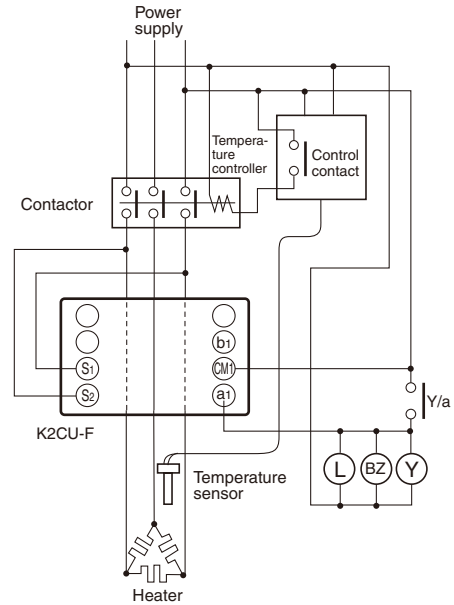

- Note:**
1. The dotted lines which pass through the heater burnout detector indicate the line conductor passing through the round "window" of the window-type Current Transformer.
  2. Y: External relay for self-holding circuit  
BZ: Alarm buzzer  
L: Alarm indicator
  3. To use a 100 (110) VAC control power supply with K2CU-P, connect it to terminal 7 instead of 6.

## Three-phase, V-connected Heater



**Note:** The dotted lines which pass through the heater burnout detector indicate the line conductor passing through the round “window” of the window-type Current Transformer.

## With External Current Transformer



**Note:** Pass two out of the three line conductors through the current transformers of the heater burnout detector twice as shown.

## K2CU-P Small-capacity, Plug-in Models

### Small-capacity Heater

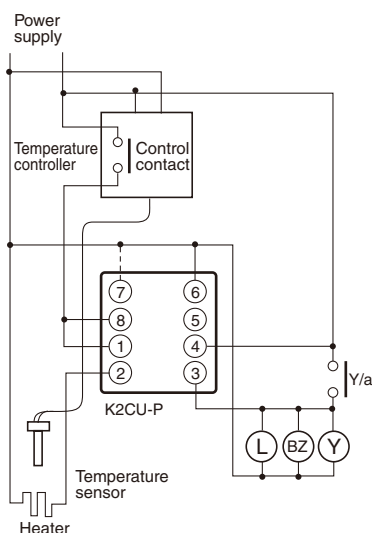

### With External Current Transformer

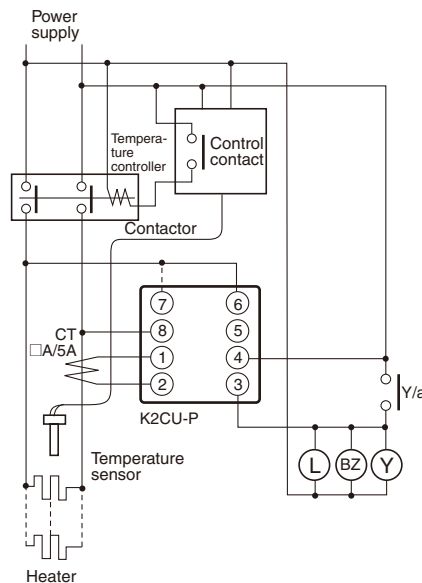

**Note:** 1. The dotted lines which pass through the heater burnout detector indicate the line conductor passing through the round “window” of the window-type Current Transformer.

2. Y: External relay for self-holding circuit  
BZ: Alarm buzzer  
L: Alarm indicator

3. To use a 100 (110) VAC control power supply with K2CU-P, connect it to terminal 7 instead of 6.

# Safety Precautions

## K2CU-F□□A-□GS

Use the K2CU-F□□A-□GS (with gate input terminals) in combination with a temperature controller that has PID with feed-forward circuitry to control the heater temperature, in which case, the heater element(s) must be turned ON or OFF for 0.1 s or longer.

## K2CU-F

When a single-phase heater is used, pass the two lines through the openings of the heater burnout detector. When a three-phase heater is used, pass two (phases) of the three lines through the openings. In either case, if only one line passes through, an alarm signal will always be produced.



Pass the lines through the openings only once. If they are passed more than once, the actual operating current will be less than the set current. The lines can be passed in either direction.

To use the heater burnout detector at a current less than the current range that can be set, the lines must be passed more than once. Determine the number of times the lines should be passed by the following equation:

$$(\text{Operating current}) \times n = \text{Current setting range}$$

where,

n: number of times the lines loop through the window

All K2CU-F models incorporate a voltage fluctuation compensation function.

## K2CU-P

The K2CU-P can be used only in single-phase circuits.

Do not pull out the K2CU-P from the socket when the K2CU-P is energized. Especially when using it in combination with a Current Transformer commercially available, this practice causes the secondary circuit of the transformer to open, which is very dangerous.

## General

Refer to *External Connections* before using the K2CU with external CTs.

When a temperature controller is used in combination with the K2CU (except for the K2CU-F□□A-□GS), the heater element(s) must be turned ON or OFF for 1 s or longer (although the heater element(s) can be turned ON for 0.5 s according to the specifications).

The K2CU cannot be used with a phase-control circuit, inverter circuit, frequency-count circuit, cycle-control unit, or a motor load.

## Mounting

Securely mount the K2CU as horizontally as possible although there is no particular limitation of mounting directions.

## Connection

Solderless-type terminal must be connected to the terminals securely.

Wire the terminals correctly by referring to the external connections. The terminals have no polarity. Be sure to connect 100 (or 110) V to the 100-V (or 110-V) terminals and 200 (or 220) V to the 200-V (or 220-V) terminals of the K2CU-P or the K2CU-P may malfunction.

The control power source for the K2CU (except for the K2CU-F□□A-□GS) must be supplied from the load side via a contactor.

Be sure to impose a voltage between the 0-V terminal and 100-V (or 110-V) terminal or the 0-V terminal and 200-V (or 220-V) terminal of the K2CU-P, otherwise the K2CU-P will not operate.

## Q &amp; A

**Q** What settings are required to connect more than one heater in parallel?

**A** The following table shows relative changes in the current when any one of several elements connected in parallel has burned out. Use this table as a guideline in determining the current setting. The degree of change in the current when an element burns out may be too small to detect if more than five elements are connected in parallel. As a rule, do not connect more than 5 elements in parallel.

Connection		n = 1	n = 2	n = 3	n = 4	n = 5
Single-phase 	No. of heater = n	I is 0 when one element burns out	0.5	0.67	0.75	0.8
Star 	Current in burned-out phase	I is 0 when one element burns out	0.6	0.75	0.82	0.86
	Current in other phases	0.87	0.92	0.95	0.96	0.97
Delta 	Current in burned-out phase	0.58	0.77	0.84	0.88	0.91
	Current in other phases	1	1	1	1	1

- Note:**
1. This table shows the respective change rates in current when any one of several elements connected in parallel has burned out.
  2. The values in the table are current ratios after one element burns out in comparison to a normal current of "1" (i.e., the current before the element burns out).
  3. The values in this table are logical values. These values may vary slightly because of influence of unbalanced loads (heaters). It is therefore recommended to test the actual current values and the load condition before determining the operating current, especially when the current under the normal condition and that under an abnormal condition do not significantly differ.

**Q** Can the K2CU be used for heaters with a voltage of 400/440?

**A** Yes. It can be used if a power transformer is used to drop the voltage applied to the control power supply voltage terminals of the K2CU to 100 to 220 V.

**Q** Can the control power supply for the K2CU be connected from a separate circuit from the one used for the heater circuit?

**A** With a model with a large-capacity, built-in current transformer, changes in the control power supply voltage are used in compensating the reference value for the internal setting circuit. A large error may occur in the operating value if power is supplied from a separate circuit.

**Q** Can the K2CU be used for three-phase circuits with unbalanced currents?

**A** Unbalanced currents can exist because of different heater capacities or because different numbers of elements are connected to each phase, causing the current for each phase to be different even during normal operation.

There is only one setting provided for the two holes on the K2CU, so the setting must be made below the current value for the phase with the lowest current. This could prevent the current from dropping below the set value depending on the element that burns out. It is thus not possible to detect heater burnouts for all elements connected with unbalanced currents. Either balanced circuits must be used, or a separate K2CU must be installed for each phase.

ALL DIMENSIONS SHOWN ARE IN MILLIMETERS.

To convert millimeters into inches, multiply by 0.03937. To convert grams into ounces, multiply by 0.03527.

In the interest of product improvement, specifications are subject to change without notice.

## Read and Understand This Catalog

Please read and understand this catalog before purchasing the products. Please consult your OMRON representative if you have any questions or comments.

## Warranty and Limitations of Liability

### WARRANTY

OMRON's exclusive warranty is that the products are free from defects in materials and workmanship for a period of one year (or other period if specified) from date of sale by OMRON.

OMRON MAKES NO WARRANTY OR REPRESENTATION, EXPRESS OR IMPLIED, REGARDING NON-INFRINGEMENT, MERCHANTABILITY, OR FITNESS FOR PARTICULAR PURPOSE OF THE PRODUCTS. ANY BUYER OR USER ACKNOWLEDGES THAT THE BUYER OR USER ALONE HAS DETERMINED THAT THE PRODUCTS WILL SUITABLY MEET THE REQUIREMENTS OF THEIR INTENDED USE. OMRON DISCLAIMS ALL OTHER WARRANTIES, EXPRESS OR IMPLIED.

### LIMITATIONS OF LIABILITY

OMRON SHALL NOT BE RESPONSIBLE FOR SPECIAL, INDIRECT, OR CONSEQUENTIAL DAMAGES, LOSS OF PROFITS, OR COMMERCIAL LOSS IN ANY WAY CONNECTED WITH THE PRODUCTS, WHETHER SUCH CLAIM IS BASED ON CONTRACT, WARRANTY, NEGLIGENCE, OR STRICT LIABILITY.

In no event shall responsibility of OMRON for any act exceed the individual price of the product on which liability is asserted.

IN NO EVENT SHALL OMRON BE RESPONSIBLE FOR WARRANTY, REPAIR, OR OTHER CLAIMS REGARDING THE PRODUCTS UNLESS OMRON'S ANALYSIS CONFIRMS THAT THE PRODUCTS WERE PROPERLY HANDLED, STORED, INSTALLED, AND MAINTAINED AND NOT SUBJECT TO CONTAMINATION, ABUSE, MISUSE, OR INAPPROPRIATE MODIFICATION OR REPAIR.

## Application Considerations

### SUITABILITY FOR USE

OMRON shall not be responsible for conformity with any standards, codes, or regulations that apply to the combination of products in the customer's application or use of the product.

At the customer's request, OMRON will provide applicable third party certification documents identifying ratings and limitations of use that apply to the products. This information by itself is not sufficient for a complete determination of the suitability of the products in combination with the end product, machine, system, or other application or use.

The following are some examples of applications for which particular attention must be given. This is not intended to be an exhaustive list of all possible uses of the products, nor is it intended to imply that the uses listed may be suitable for the products:

- Outdoor use, uses involving potential chemical contamination or electrical interference, or conditions or uses not described in this catalog.
- Nuclear energy control systems, combustion systems, railroad systems, aviation systems, medical equipment, amusement machines, vehicles, safety equipment, and installations subject to separate industry or government regulations.
- Systems, machines, and equipment that could present a risk to life or property.

Please know and observe all prohibitions of use applicable to the products.

NEVER USE THE PRODUCTS FOR AN APPLICATION INVOLVING SERIOUS RISK TO LIFE OR PROPERTY WITHOUT ENSURING THAT THE SYSTEM AS A WHOLE HAS BEEN DESIGNED TO ADDRESS THE RISKS, AND THAT THE OMRON PRODUCT IS PROPERLY RATED AND INSTALLED FOR THE INTENDED USE WITHIN THE OVERALL EQUIPMENT OR SYSTEM.

## Disclaimers

### CHANGE IN SPECIFICATIONS

Product specifications and accessories may be changed at any time based on improvements and other reasons.

It is our practice to change model numbers when published ratings or features are changed, or when significant construction changes are made. However, some specifications of the product may be changed without any notice. When in doubt, special model numbers may be assigned to fix or establish key specifications for your application on your request. Please consult with your OMRON representative at any time to confirm actual specifications of purchased product.

### DIMENSIONS AND WEIGHTS

Dimensions and weights are nominal and are not to be used for manufacturing purposes, even when tolerances are shown.

### ERRORS AND OMISSIONS

The information in this catalog has been carefully checked and is believed to be accurate; however, no responsibility is assumed for clerical, typographical, or proofreading errors, or omissions.

### PERFORMANCE DATA

Performance data given in this catalog is provided as a guide for the user in determining suitability and does not constitute a warranty. It may represent the result of OMRON's test conditions, and the users must correlate it to actual application requirements. Actual performance is subject to the OMRON Warranty and Limitations of Liability.

### PROGRAMMABLE PRODUCTS

OMRON shall not be responsible for the user's programming of a programmable product, or any consequence thereof.

### COPYRIGHT AND COPY PERMISSION

This catalog shall not be copied for sales or promotions without permission.

This catalog is protected by copyright and is intended solely for use in conjunction with the product. Please notify us before copying or reproducing this catalog in any manner, for any other purpose. If copying or transmitting this catalog to another, please copy or transmit it in its entirety.

Компания «Океан Электроники» предлагает заключение долгосрочных отношений при поставках импортных электронных компонентов на взаимовыгодных условиях!

Наши преимущества:

- Поставка оригинальных импортных электронных компонентов напрямую с производств Америки, Европы и Азии, а так же с крупнейших складов мира;
- Широкая линейка поставок активных и пассивных импортных электронных компонентов (более 30 млн. наименований);
- Поставка сложных, дефицитных, либо снятых с производства позиций;
- Оперативные сроки поставки под заказ (от 5 рабочих дней);
- Экспресс доставка в любую точку России;
- Помощь Конструкторского Отдела и консультации квалифицированных инженеров;
- Техническая поддержка проекта, помощь в подборе аналогов, поставка прототипов;
- Поставка электронных компонентов под контролем ВП;
- Система менеджмента качества сертифицирована по Международному стандарту ISO 9001;
- При необходимости вся продукция военного и аэрокосмического назначения проходит испытания и сертификацию в лаборатории (по согласованию с заказчиком);
- Поставка специализированных компонентов военного и аэрокосмического уровня качества (Xilinx, Altera, Analog Devices, Intersil, Interpoint, Microsemi, Actel, Aeroflex, Peregrine, VPT, Syfer, Eurofarad, Texas Instruments, MS Kennedy, Miteq, Cobham, E2V, MA-COM, Hittite, Mini-Circuits, General Dynamics и др.);

Компания «Океан Электроники» является официальным дистрибьютором и эксклюзивным представителем в России одного из крупнейших производителей разъемов военного и аэрокосмического назначения «**JONHON**», а так же официальным дистрибьютором и эксклюзивным представителем в России производителя высокотехнологичных и надежных решений для передачи СВЧ сигналов «**FORSTAR**».



## JONHON

«**JONHON**» (основан в 1970 г.)

Разъемы специального, военного и аэрокосмического назначения:

(Применяются в военной, авиационной, аэрокосмической, морской, железнодорожной, горно- и нефтедобывающей отраслях промышленности)

«**FORSTAR**» (основан в 1998 г.)

ВЧ соединители, коаксиальные кабели,  
кабельные сборки и микроволновые компоненты:

(Применяются в телекоммуникациях гражданского и специального назначения, в средствах связи, РЛС, а так же военной, авиационной и аэрокосмической отраслях промышленности).



Телефон: 8 (812) 309-75-97 (многоканальный)

Факс: 8 (812) 320-03-32

Электронная почта: [ocean@oceanchips.ru](mailto:ocean@oceanchips.ru)

Web: <http://oceanchips.ru/>

Адрес: 198099, г. Санкт-Петербург, ул. Калинина, д. 2, корп. 4, лит. А