

SST11CP16 is a versatile power amplifier based on the highly-reliable InGaP/GaAs HBT technology. It is easily configured for high-linearity, high-efficiency applications, with superb power-added efficiency, while operating over the 5.1-5.9 GHz frequency band. SST11CP16 has the excellent linearity required by the 802.11a/n/ac applications. SST11CP16 provides 19 dBm with less than 1.8% EVM using 802.11ac modulation, with 80 MHz bandwidths and 351 Mbps data rate. It meets 802.11a spectrum mask requirements at 25 dBm and 802.11n HT20 spectrum mask at 24.5 dBm. This power amplifier also features easy, board-level usage along with high-speed power-up/-down control through a single reference voltage pin. SST11CP16 is offered in a 16-contact XQFN package with 0.5mm maximum thickness.

Features

- **Small package size**
 - 16-contact XQFN (3mm x 3mm x 0.5mm max thickness)
- **Operating voltage**
 - $V_{CC} = 5.0V$
- **High linear output power across 5.1-5.9 GHz @ 5V:**
 - 802.11a OFDM Spectrum mask compliant up to 25 dBm typically
 - 802.11n HT20 OFDM Spectrum mask compliant up to 24.5 dBm typically
 - 3% EVM up to 21.5 dBm, typically for 802.11a, 54 Mbps signal
 - 2.5% EVM up to 20 dBm, typically for 802.11n, MCS7, 40 MHz BW signal
 - 1.8% EVM up to 19 dBm, typically for 802.11ac, MCS9, 80 MHz BW signal
- **High power-added efficiency/low operating current for 54 Mbps 802.11a applications**
 - ~11% @ $P_{OUT} = 23$ dBm for 802.11a OFDM, 5V V_{CC}
- **Gain:**
 - Typically 30 dB gain across band 5.1-5.9 GHz
- **Idle current**
 - ~250 mA I_{CQ}
- **High speed power-up/-down**
 - Turn on/off time (10%~90%) <100 ns
- **Low shut-down current (~1 μA)**
- **On-chip power detection**
 - 20 dB linear dynamic range
- **50 Ω on-chip input match and simple output match**
- **All lead-free devices are RoHS compliant**

Applications

- **WLAN (IEEE 802.11a/n/ac)**
- **HyperLAN2**
- **Multimedia**

Product Description

SST11CP16 is a high-linearity power amplifier with low power consumption and is based on the highly-reliable InGaP/GaAs HBT technology. It can be easily configured for high-linearity, high-efficiency applications, with superb power-added efficiency, while operating over the 802.11a frequency band for U.S. and European markets (5.1-5.9 GHz).

SST11CP16 has excellent linearity, typically ~3% added EVM at 21.5 dBm output power for 54 Mbps 802.11a operation, at 5.0V, while meeting 802.11a spectrum mask at 25 dBm. SST11CP16 provides 19 dBm with less than 1.8% EVM, using 802.11ac modulation with 80 MHz bandwidth and 351 Mbps data rate. This power amplifier also provides a wide dynamic-range, linear power detector that is temperature and VSWR insensitive. This integrated power detector can lower the cost of power control.

The power amplifier IC also features easy board-level operation along with high-speed power-up/down control. Low reference current (total $I_{REF} < 8$ mA) makes the SST11CP16 controllable by an on/off switching signal directly from the baseband chip. These features coupled with low operating current make the SST11CP16 ideal for the final stage power amplification in 802.11a/n/ac WLAN transmitter applications.

The SST11CP16 is offered in 16-contact XQFN package with 0.5 mm maximum thickness. See Figure 2 for pin assignments and Table 1 for pin descriptions.

Functional Blocks

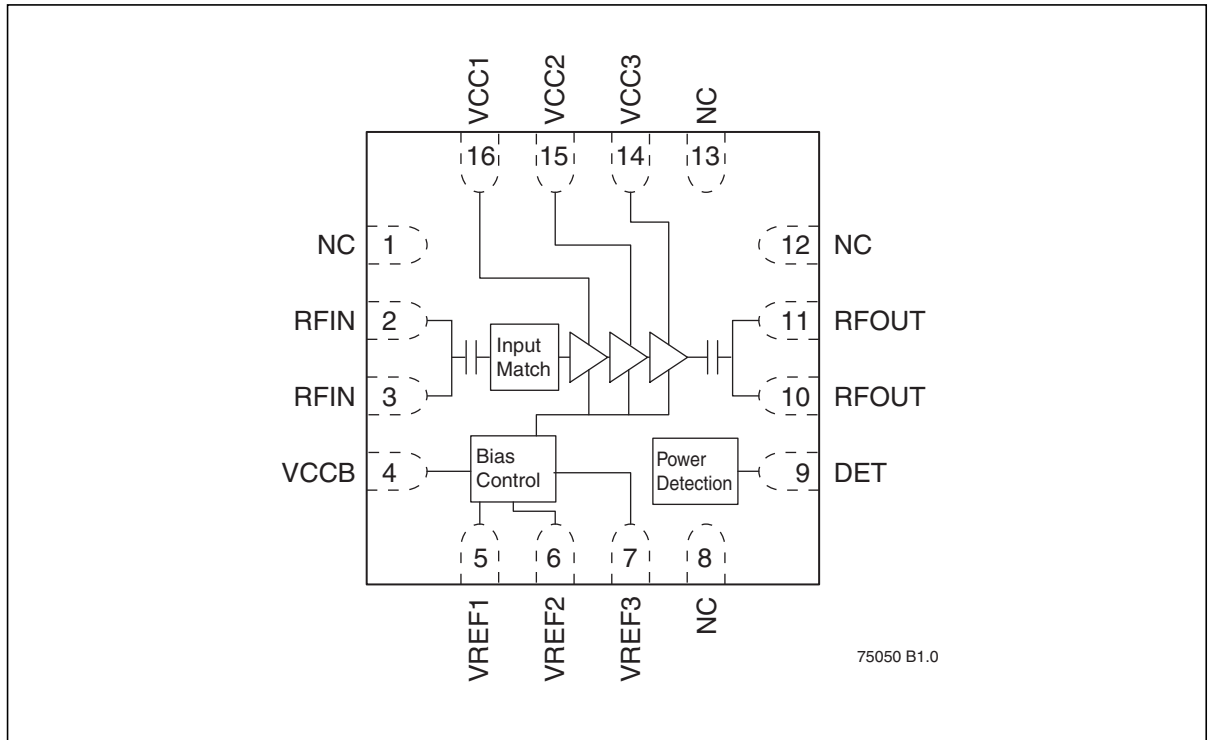

Figure 1: Functional Block Diagram

Pin Assignments

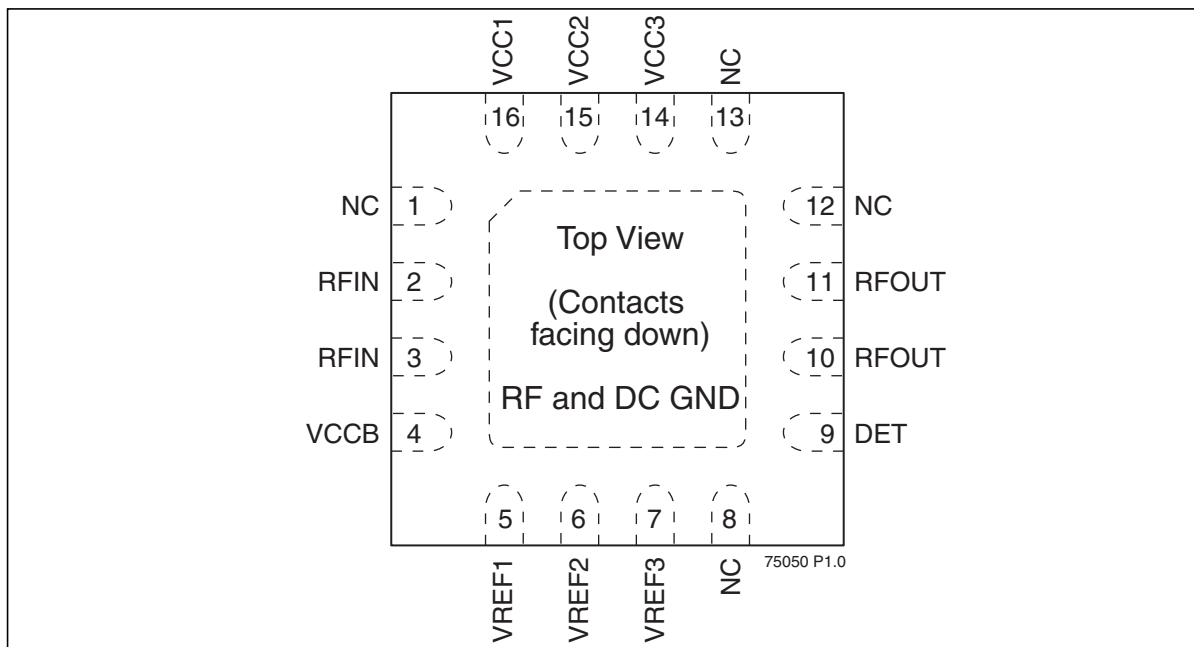

Figure 2: Pin Assignments for 16-contact XQFN

Pin Descriptions

Table 1: Pin Description

Symbol	Pin No.	Pin Name	Type ¹	Function
GND	0	Ground		The center pad should be connected to RF ground with several low inductance, low resistance vias.
NC	1	No Connection		Unconnected pin
RFIN	2		I	RF input, DC decoupled
RFIN	3		I	RF input, DC decoupled
VCCb	4	Power Supply	PWR	Supply voltage for bias circuit
VREF1	5		PWR	Current Control
VREF2	6		PWR	Current Control
VREF3	7		PWR	Current Control
NC	8	No Connection		Unconnected pin
DET	9		O	On-chip power detector
RFOUT	10		O	RF Output, DC decoupled
RFOUT	11		O	RF Output, DC decoupled
NC	12	No Connection		Unconnected pin
NC	13	No Connection		Unconnected pin
VCC3	14	Power Supply	PWR	Power supply, 3 rd stage
VCC2	15	Power Supply	PWR	Power supply, 2 nd stage
VCC1	16	Power Supply	PWR	Power supply, 1 st stage

1. I=Input, O=Output

Electrical Specifications

The AC and DC specifications for the power amplifier interface signals. Refer to Table 3 for the DC voltage and current specifications. Refer to Figures 4 through 8 for RF performance.

Absolute Maximum Stress Ratings (Applied conditions greater than those listed under “Absolute Maximum Stress Ratings” may cause permanent damage to the device. This is a stress rating only and functional operation of the device at these conditions or conditions greater than those defined in the operational sections of this data sheet is not implied. Exposure to absolute maximum stress rating conditions may affect device reliability.)

Supply Voltage at pins 4, 14, 15, and 16 (V_{CC})	-0.3V to +5.9V
Supply Voltage at pins 5,6, and 7 (V_{REF})	-0.3V to +3.6V
DC supply current (I_{CC})	600 mA
Operating Temperature (T_A)	-20°C to +85°C
Storage Temperature (T_{STG})	-40°C to +120°C
Maximum Junction Temperature (T_J)	+150°C
Maximum Output Power	27 dBm
Surface Mount Solder Reflow Temperature	260°C for 10 seconds

Table 2: Operating Range

Range	Ambient Temp	V _{CC}
Industrial	-10°C to +85°C	5.0V-5.5V

T2.1 75050

Table 3: DC Electrical Characteristics

Symbol	Parameter	Min.	Typ	Max.	Unit
V_{CC}	Supply Voltage		5.0		V
I_{CC}	Supply Current @ $P_{OUT} = 22$ dBm $V_{CC} = 5.0V$		340		mA
I_{CQ}	V_{CC} Quiescent Current $V_{CC} = 5.0V$		250		mA
I_{OFF}	Shut down current		1.0	10	μA
V_{REG}	Recommended Reference Voltage		2.85		V
I_{REG}	Total Reference Current		8		mA
V_{DET}	RF Power Detector Voltage Output level	0.4		1.1	V

T3.0 75050

Table 4: AC Electrical Characteristics for Configuration, $V_{CC} = 5.0V^1$, $V_{REG} = 2.85V$

Symbol	Parameter	Min	Typ	Max	Unit
F _{L-U}	Frequency range	5.1		5.9	GHz
Linear Power	Output power at 3% EVM at 54 Mbps OFDM signal, 802.11a		21.5		dBm
	Output power at 2.5% EVM at 54 Mbps OFDM signal, 802.11a		20		dBm
	Output power at 1.8% EVM at 802.11ac, MCS9 80 MHz		19		dBm
ACPR _a	Output power level with 802.11a mask compliance		25.5		dBm
ACPR _{n20}	Output power level with 802.11n HT20 mask compliance		24.5		dBm
Gain	Power gain from 5.18–5.9 GHz		30		dB
Input Return Loss	RF Input Return Loss		10		dB
2F _O	Second Harmonic Power Level		-26		dBm/MHz
3F _O	Third Harmonic Power Level		-35		dBm/MHz

T4.1 75050

1. EVM is measured with equalizer channel estimation set to "Sequence Only"

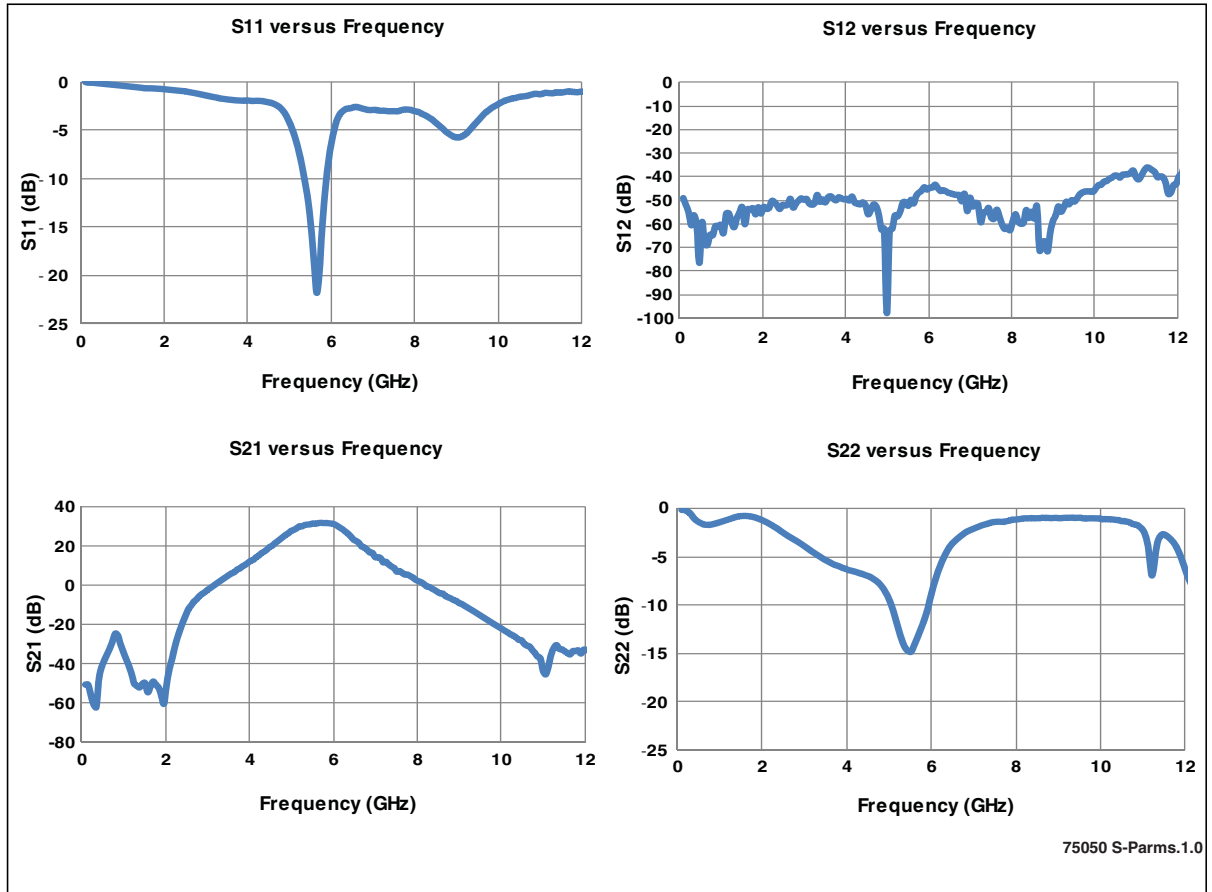

Figure 3: S-Parameters

Typical Performance characteristics

Test Conditions: $V_{CC} = 5.0V$, $T_A = 25^\circ C$, $V_{REG} = 2.85V$, 802.11a 54 Mbps OFDM Modulation unless otherwise noted

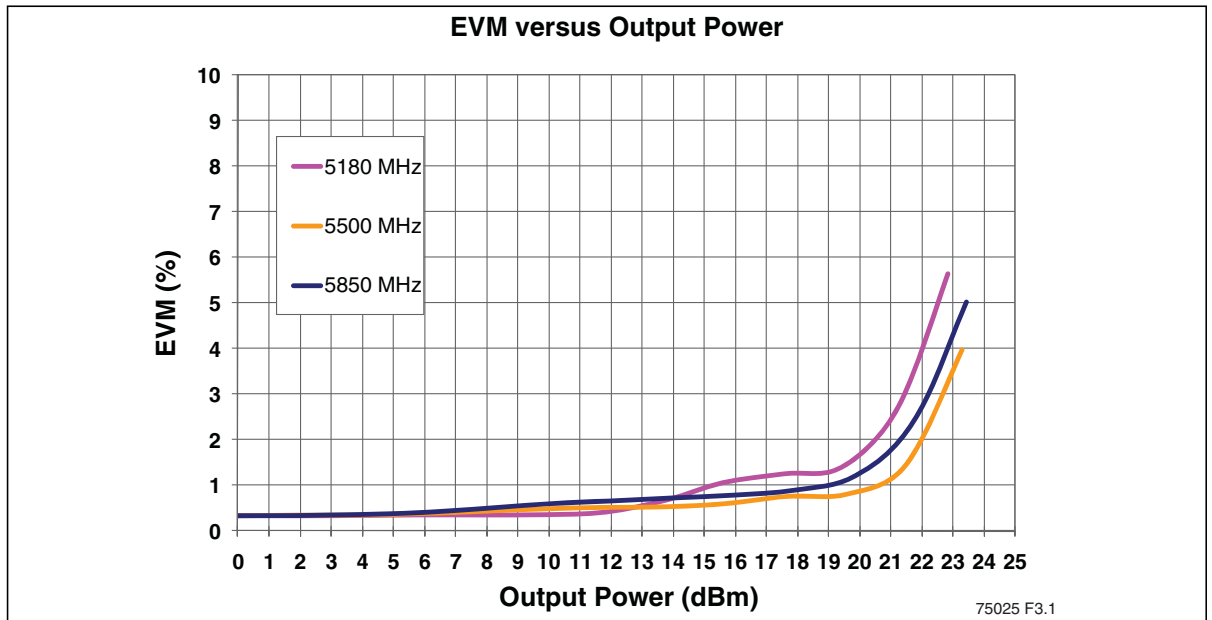

Figure 4: 802.11a 64QAM, 54 Mbps EVM versus Output Power, measured with equalizer channel estimation set to “Sequence Only”

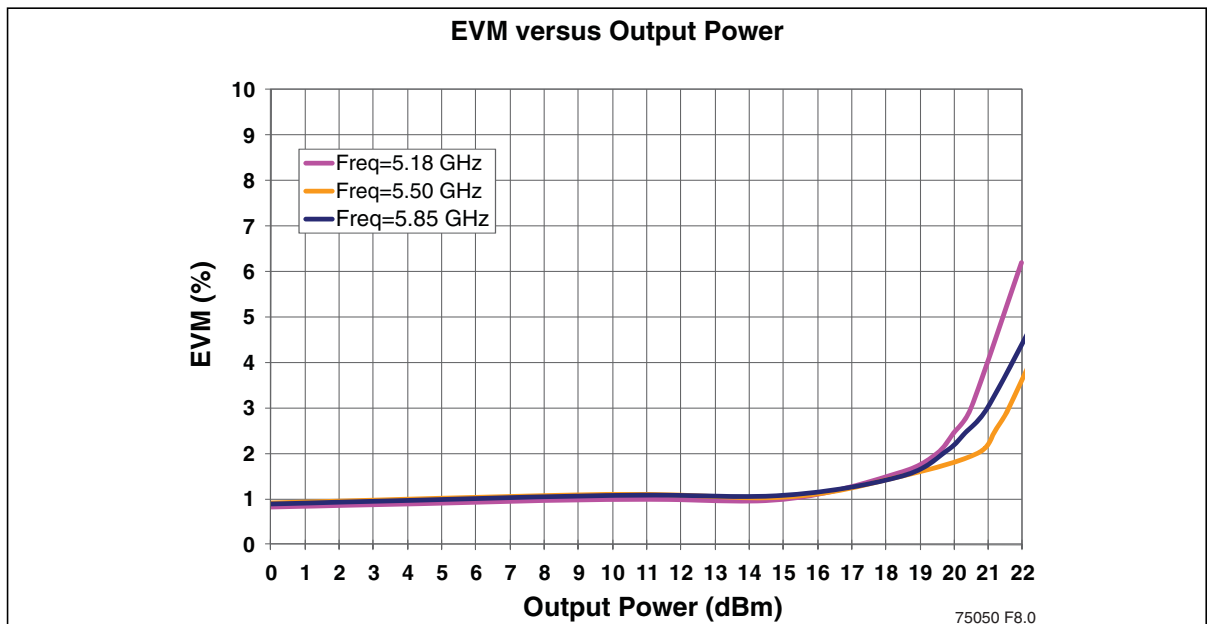

Figure 5: 802.11ac 256QAM, MCS9-80 MHz EVM versus Output Power, measured with equalizer channel estimation set to “Sequence Only”

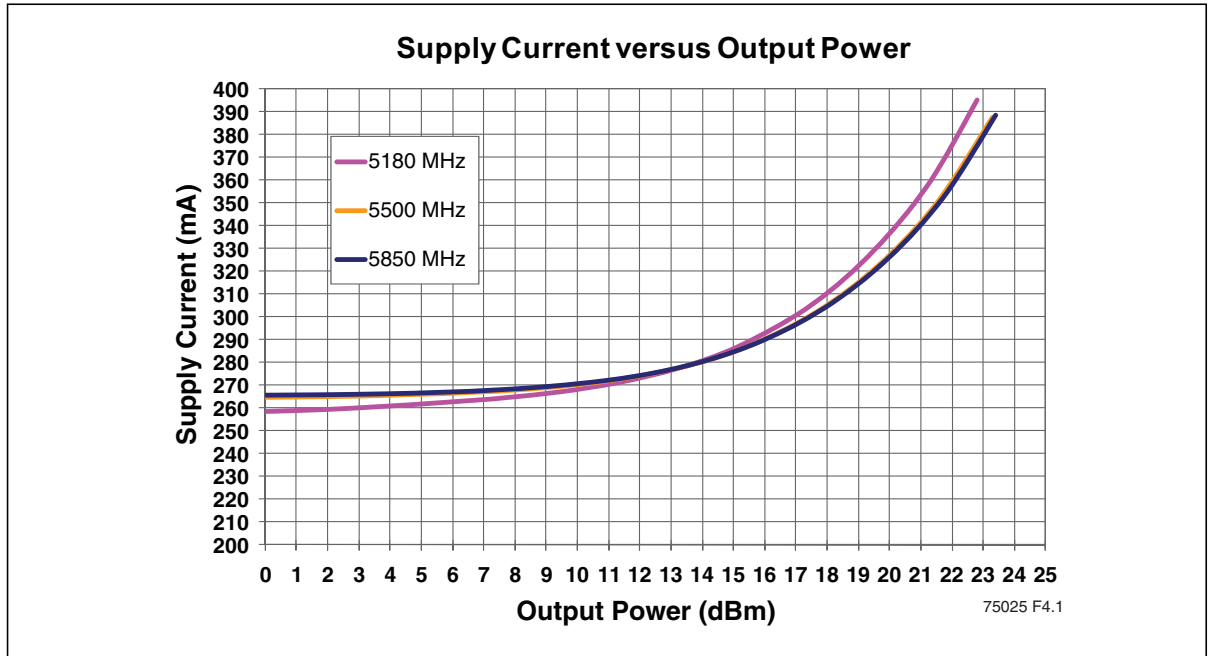

Figure 6: Power Supply Current versus Output Power, $V_{CC} = 5.0V$, $V_{REG} = 2.85$

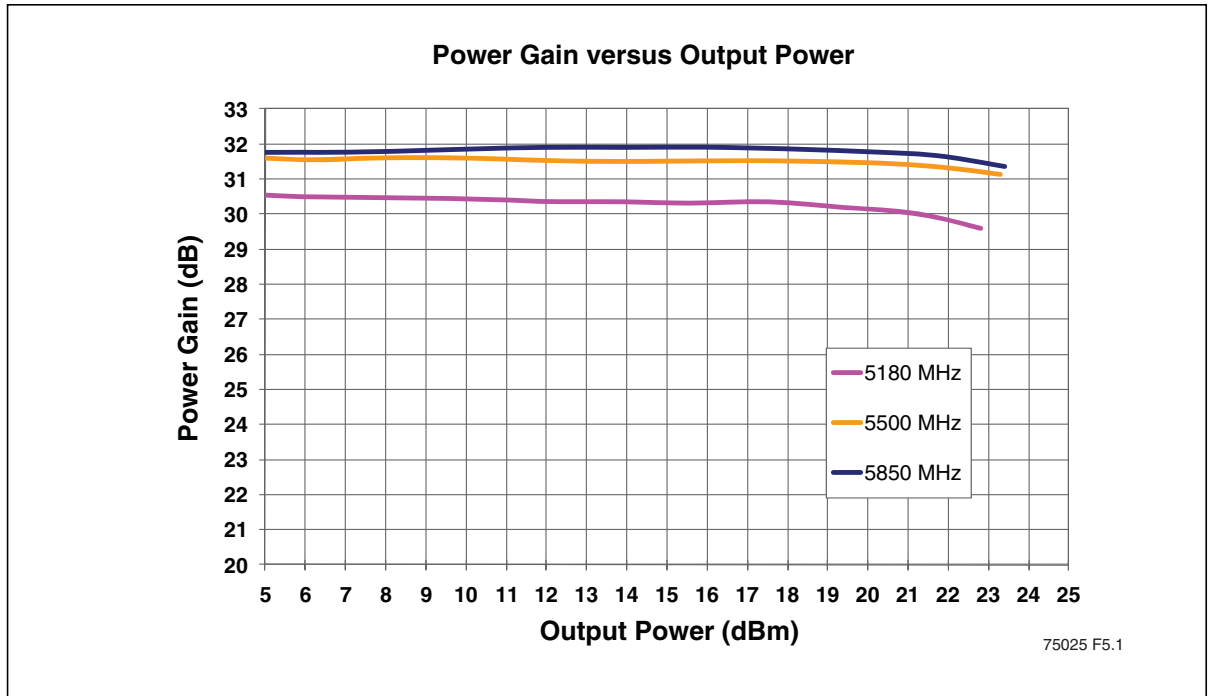

Figure 7: Power Gain versus Output Power, $V_{CC} = 5.0V$, $V_{REG} = 2.85$

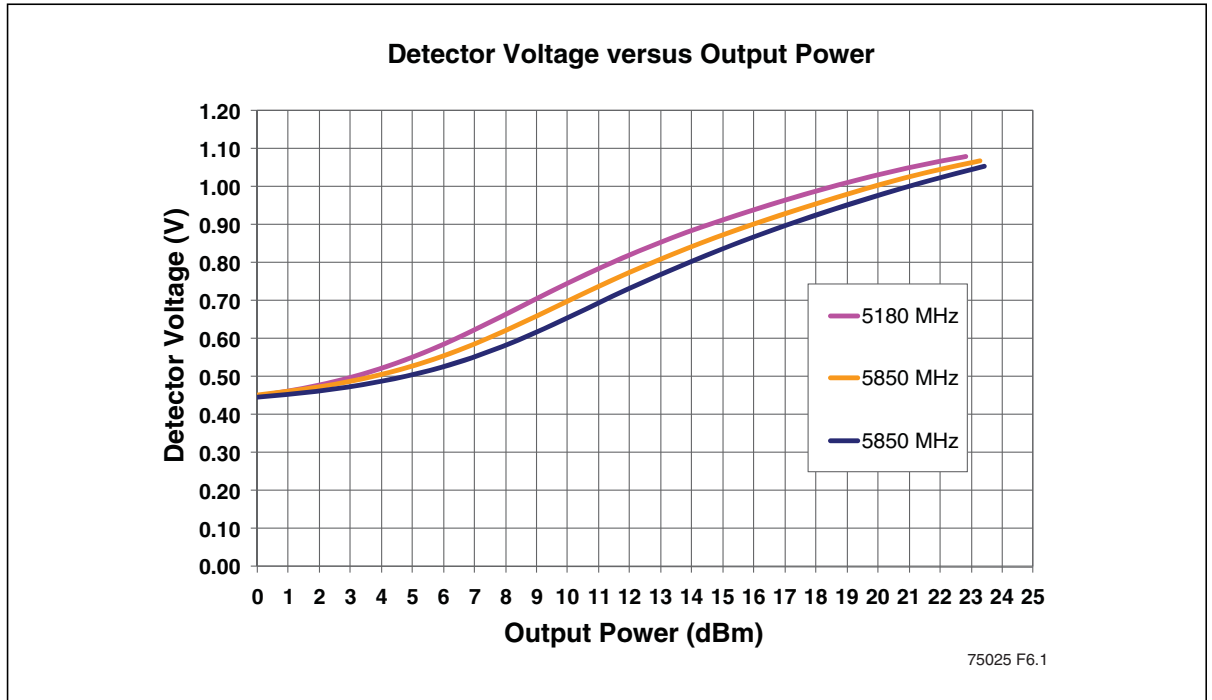

Figure 8: Detector Voltage vs Output Power, $V_{CC} = 5.0V$, $V_{REG} = 2.85$

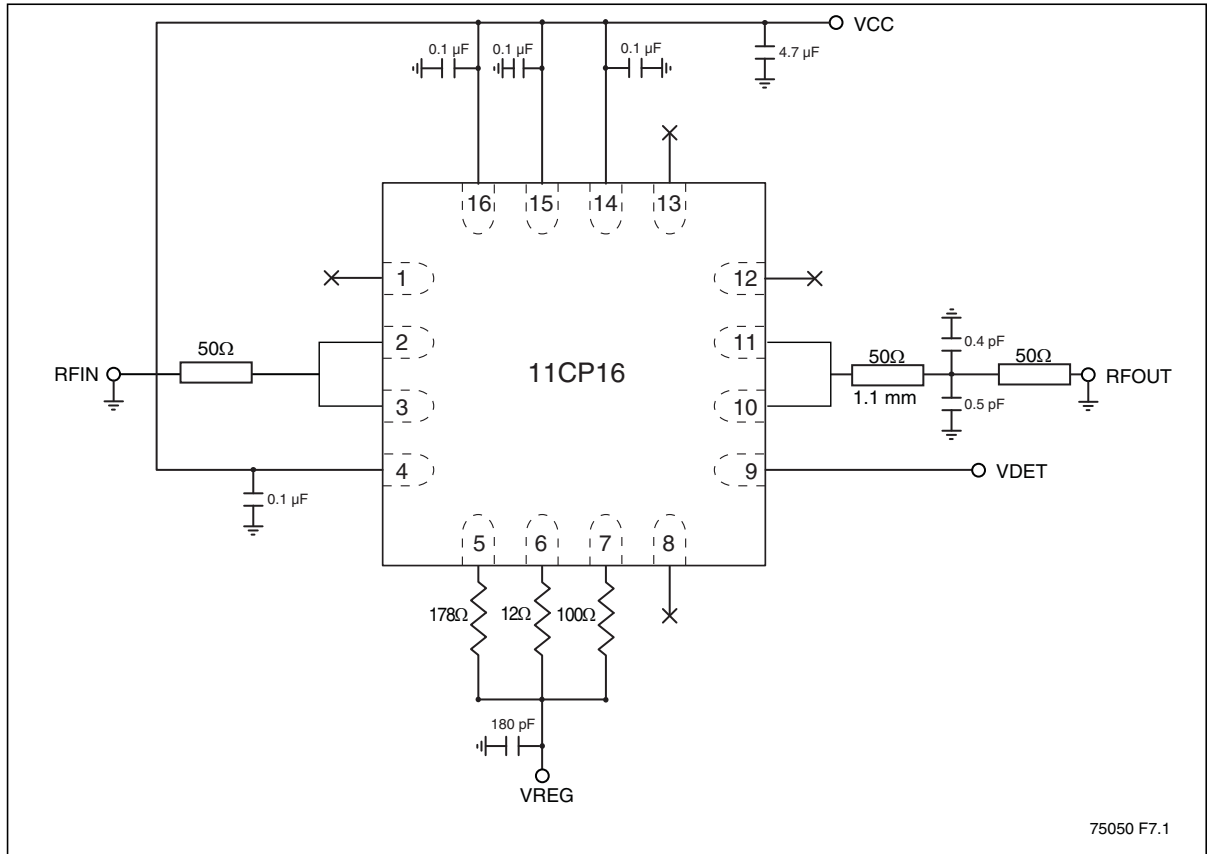
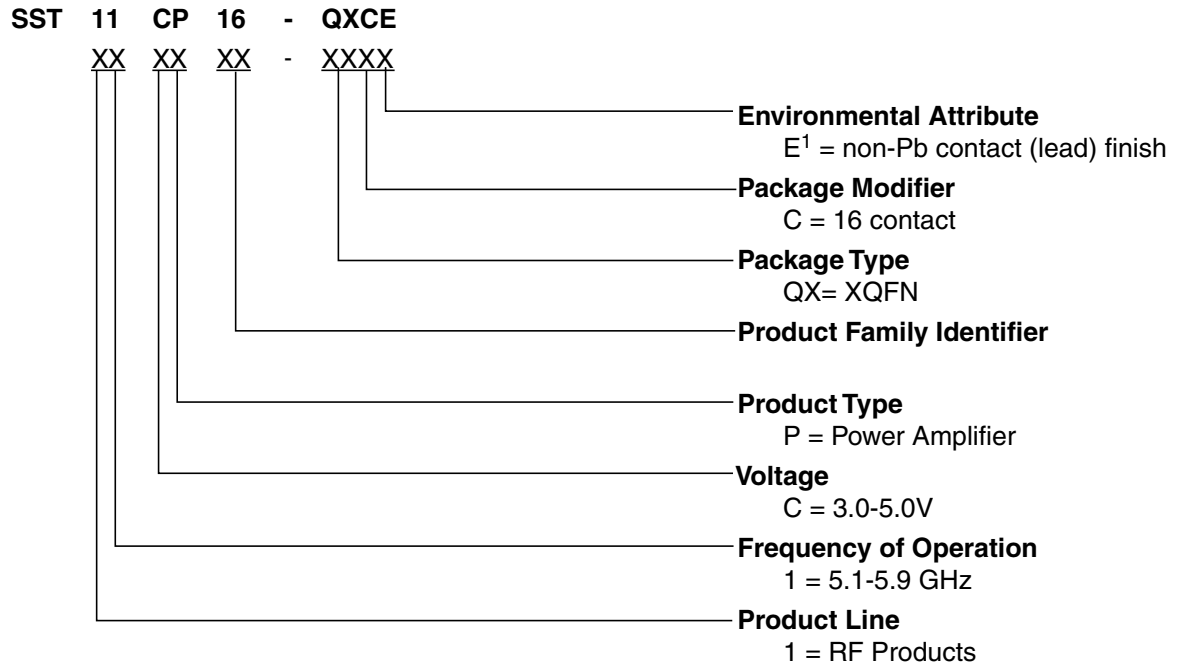

Figure 9: Typical Application for High-Linearity 802.11a/n/ac Application, $V_{CC} = 5.0V$, $V_{REG} = 2.85$

Product Ordering Information



1. Environmental suffix "E" denotes non-Pb solder. SST non-Pb solder devices are "RoHS Compliant".

Valid combinations for SST11CP16

SST11CP16-QXCE

SST11CP16 Evaluation Kits

SST11CP16-QXCE-K

Note: Valid combinations are those products in mass production or will be in mass production. Consult your SST sales representative to confirm availability of valid combinations and to determine availability of new combinations.

Packaging Diagrams

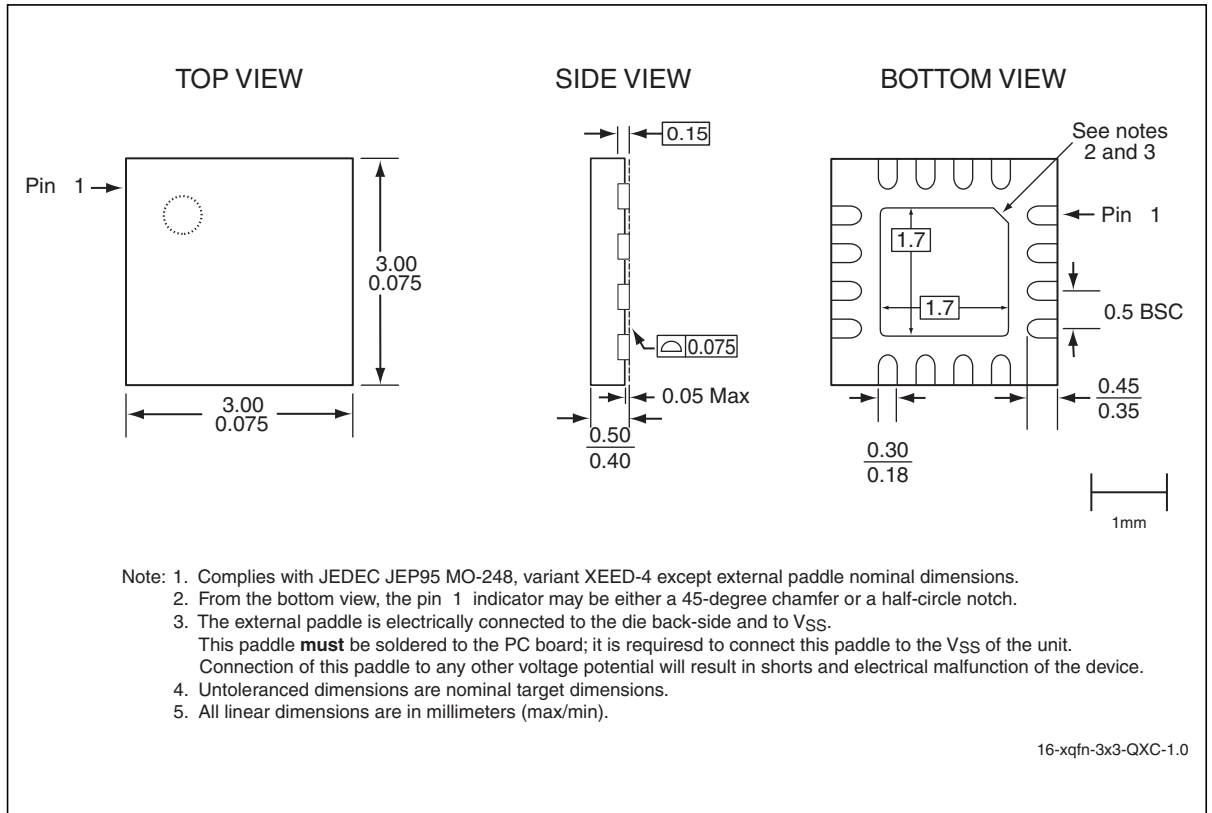

Figure 10: 16-contact Extremely-thin Quad Flat No-lead (XQFN)
SST Package Code: QXC

Table 5: Revision History

Revision	Description	Date
A	<ul style="list-style-type: none">Initial Release of Data Sheet	Aug 2012
B	<ul style="list-style-type: none">Updated Reference current values in Table 3 on page 5Revised FeaturesUpdated Table 4 on page 6	Sep 2014

ISBN:978-1-63276-606-9

© 2014 Microchip Technology Inc.

SST, Silicon Storage Technology, the SST logo, SuperFlash, and MTP are registered trademarks of Microchip Technology, Inc. MPF, SQI, Serial Quad I/O, and Z-Scale are trademarks of Microchip Technology, Inc. All other trademarks and registered trademarks mentioned herein are the property of their respective owners.

Specifications are subject to change without notice. Refer to www.microchip.com for the most recent documentation. For the most current package drawings, please see the Packaging Specification located at <http://www.microchip.com/packaging>.

Memory sizes denote raw storage capacity; actual usable capacity may be less.

Microchip makes no warranty for the use of its products other than those expressly contained in the Standard Terms and Conditions of Sale.

For sales office locations and information, please see www.microchip.com.

www.microchip.com

Компания «Океан Электроники» предлагает заключение долгосрочных отношений при поставках импортных электронных компонентов на взаимовыгодных условиях!

Наши преимущества:

- Поставка оригинальных импортных электронных компонентов напрямую с производств Америки, Европы и Азии, а так же с крупнейших складов мира;
- Широкая линейка поставок активных и пассивных импортных электронных компонентов (более 30 млн. наименований);
- Поставка сложных, дефицитных, либо снятых с производства позиций;
- Оперативные сроки поставки под заказ (от 5 рабочих дней);
- Экспресс доставка в любую точку России;
- Помощь Конструкторского Отдела и консультации квалифицированных инженеров;
- Техническая поддержка проекта, помощь в подборе аналогов, поставка прототипов;
- Поставка электронных компонентов под контролем ВП;
- Система менеджмента качества сертифицирована по Международному стандарту ISO 9001;
- При необходимости вся продукция военного и аэрокосмического назначения проходит испытания и сертификацию в лаборатории (по согласованию с заказчиком);
- Поставка специализированных компонентов военного и аэрокосмического уровня качества (Xilinx, Altera, Analog Devices, Intersil, Interpoint, Microsemi, Actel, Aeroflex, Peregrine, VPT, Syfer, Eurofarad, Texas Instruments, MS Kennedy, Miteq, Cobham, E2V, MA-COM, Hittite, Mini-Circuits, General Dynamics и др.);

Компания «Океан Электроники» является официальным дистрибьютором и эксклюзивным представителем в России одного из крупнейших производителей разъемов военного и аэрокосмического назначения «JONHON», а так же официальным дистрибьютором и эксклюзивным представителем в России производителя высокотехнологичных и надежных решений для передачи СВЧ сигналов «FORSTAR».



JONHON

«JONHON» (основан в 1970 г.)

Разъемы специального, военного и аэрокосмического назначения:

(Применяются в военной, авиационной, аэрокосмической, морской, железнодорожной, горно- и нефтедобывающей отраслях промышленности)

«FORSTAR» (основан в 1998 г.)

ВЧ соединители, коаксиальные кабели, кабельные сборки и микроволновые компоненты:

(Применяются в телекоммуникациях гражданского и специального назначения, в средствах связи, РЛС, а так же военной, авиационной и аэрокосмической отраслях промышленности).



Телефон: 8 (812) 309-75-97 (многоканальный)

Факс: 8 (812) 320-03-32

Электронная почта: ocean@oceanchips.ru

Web: <http://oceanchips.ru/>

Адрес: 198099, г. Санкт-Петербург, ул. Калинина, д. 2, корп. 4, лит. А