



LatticeECP3 Family Data Sheet

Preliminary DS1021 Version 01.6, March 2010

Features

■ Higher Logic Density for Increased System Integration

- 17K to 149K LUTs
- 133 to 586 I/Os

■ Embedded SERDES

- 150 Mbps to 3.2 Gbps for Generic 8b10b, 10-bit SERDES, and 8-bit SERDES modes
- Data Rates 230 Mbps to 3.2 Gbps per channel for all other protocols
- Up to 16 channels per device: PCI Express, SONET/SDH, Ethernet (1GbE, SGMII, XAU1), CPRI, SMPTE 3G and Serial RapidIO

■ sysDSP™

- Fully cascadable slice architecture
- 12 to 160 slices for high performance multiply and accumulate
- Powerful 54-bit ALU operations
- Time Division Multiplexing MAC Sharing
- Rounding and truncation
- Each slice supports
 - Half 36x36, two 18x18 or four 9x9 multipliers
 - Advanced 18x36 MAC and 18x18 Multiply-Multiply-Accumulate (MMAC) operations

■ Flexible Memory Resources

- Up to 6.85Mbits sysMEM™ Embedded Block RAM (EBR)
- 36K to 303K bits distributed RAM

■ sysCLOCK Analog PLLs and DLLs

- Two DLLs and up to ten PLLs per device

■ Pre-Engineered Source Synchronous I/O

- DDR registers in I/O cells

- Dedicated read/write levelling functionality
- Dedicated gearing logic
- Source synchronous standards support
 - ADC/DAC, 7:1 LVDS, XGMII
 - High Speed ADC/DAC devices
- Dedicated DDR/DDR2/DDR3 memory with DQS support
- Optional Inter-Symbol Interference (ISI) correction on outputs

■ Programmable sysI/O™ Buffer Supports Wide Range of Interfaces

- On-chip termination
- Optional equalization filter on inputs
- LVTTTL and LVCMOS 33/25/18/15/12
- SSTL 33/25/18/15 I, II
- HSTL15 I and HSTL18 I, II
- PCI and Differential HSTL, SSTL
- LVDS, Bus-LVDS, LVPECL, RSQS, MLVDS

■ Flexible Device Configuration

- Dedicated bank for configuration I/Os
- SPI boot flash interface
- Dual-boot images supported
- Slave SPI
- TransFR™ I/O for simple field updates
- Soft Error Detect embedded macro

■ System Level Support

- IEEE 1149.1 and IEEE 1532 compliant
- Reveal Logic Analyzer
- ORCAstra FPGA configuration utility
- On-chip oscillator for initialization & general use
- 1.2V core power supply

Table 1-1. LatticeECP3™ Family Selection Guide

Device	ECP3-17	ECP3-35	ECP3-70	ECP3-95	ECP3-150
LUTs (K)	17	33	67	92	149
sysMEM Blocks (18Kbits)	38	72	240	240	372
Embedded Memory (Kbits)	700	1327	4420	4420	6850
Distributed RAM Bits (Kbits)	36	68	145	188	303
18X18 Multipliers	24	64	128	128	320
SERDES (Quad)	1	1	3	3	4
PLLs/DLLs	2 / 2	4 / 2	10 / 2	10 / 2	10 / 2
Packages and SERDES Channels/ I/O Combinations					
256 ftBGA (17x17 mm)	4 / 133	4 / 133			
484 fpBGA (23x23 mm)	4 / 222	4 / 295	4 / 295	4 / 295	
672 fpBGA (27x27 mm)		4 / 310	8 / 380	8 / 380	8 / 380
1156 fpBGA (35x35 mm)			12 / 490	12 / 490	16 / 586

© 2009 Lattice Semiconductor Corp. All Lattice trademarks, registered trademarks, patents, and disclaimers are as listed at www.latticesemi.com/legal. All other brand or product names are trademarks or registered trademarks of their respective holders. The specifications and information herein are subject to change without notice.

Introduction

The LatticeECP3™ (Economy Plus Third generation) family of FPGA devices is optimized to deliver high performance features such as an enhanced DSP architecture, high speed SERDES and high speed source synchronous interfaces in an economical FPGA fabric. This combination is achieved through advances in device architecture and the use of 65nm technology making the devices suitable for high-volume, high-speed, low-cost applications.

The LatticeECP3 device family expands look-up-table (LUT) capacity to 149K logic elements and supports up to 486 user I/Os. The LatticeECP3 device family also offers up to 320 18x18 multipliers and a wide range of parallel I/O standards.

The LatticeECP3 FPGA fabric is optimized with high performance and low cost in mind. The LatticeECP3 devices utilize reconfigurable SRAM logic technology and provide popular building blocks such as LUT-based logic, distributed and embedded memory, Phase Locked Loops (PLLs), Delay Locked Loops (DLLs), pre-engineered source synchronous I/O support, enhanced sysDSP slices and advanced configuration support, including encryption and dual-boot capabilities.

The pre-engineered source synchronous logic implemented in the LatticeECP3 device family supports a broad range of interface standards, including DDR3, XGMII and 7:1 LVDS.

The LatticeECP3 device family also features high speed SERDES with dedicated PCS functions. High jitter tolerance and low transmit jitter allow the SERDES plus PCS blocks to be configured to support an array of popular data protocols including PCI Express, SMPTE, Ethernet (XAUI, GbE, and SGMII) and CPRI. Transmit Pre-emphasis and Receive Equalization settings make the SERDES suitable for transmission and reception over various forms of media.

The LatticeECP3 devices also provide flexible, reliable and secure configuration options, such as dual-boot capability, bit-stream encryption, and TransFR field upgrade features.

The ispLEVER® design tool suite from Lattice allows large complex designs to be efficiently implemented using the LatticeECP3 FPGA family. Synthesis library support for LatticeECP3 is available for popular logic synthesis tools. The ispLEVER tool uses the synthesis tool output along with the constraints from its floor planning tools to place and route the design in the LatticeECP3 device. The ispLEVER tool extracts the timing from the routing and back-annotates it into the design for timing verification.

Lattice provides many pre-engineered IP (Intellectual Property) ispLeverCORE™ modules for the LatticeECP3 family. By using these configurable soft core IPs as standardized blocks, designers are free to concentrate on the unique aspects of their design, increasing their productivity.

Architecture Overview

Each LatticeECP3 device contains an array of logic blocks surrounded by Programmable I/O Cells (PIC). Interspersed between the rows of logic blocks are rows of sysMEM™ Embedded Block RAM (EBR) and rows of sys-DSP™ Digital Signal Processing slices, as shown in Figure 2-1. In addition, the LatticeECP3 family contains SERDES Quads on the bottom of the device.

There are two kinds of logic blocks, the Programmable Functional Unit (PFU) and Programmable Functional Unit without RAM (PFF). The PFU contains the building blocks for logic, arithmetic, RAM and ROM functions. The PFF block contains building blocks for logic, arithmetic and ROM functions. Both PFU and PFF blocks are optimized for flexibility, allowing complex designs to be implemented quickly and efficiently. Logic Blocks are arranged in a two-dimensional array. Only one type of block is used per row.

The LatticeECP3 devices contain one or more rows of sysMEM EBR blocks. sysMEM EBRs are large, dedicated 18Kbit fast memory blocks. Each sysMEM block can be configured in a variety of depths and widths as RAM or ROM. In addition, LatticeECP3 devices contain up to two rows of DSP slices. Each DSP slice has multipliers and adder/accumulators, which are the building blocks for complex signal processing capabilities.

The LatticeECP3 devices feature up to 16 embedded 3.2Gbps SERDES (Serializer / Deserializer) channels. Each SERDES channel contains independent 8b/10b encoding / decoding, polarity adjust and elastic buffer logic. Each group of four SERDES channels, along with its Physical Coding Sub-layer (PCS) block, creates a quad. The functionality of the SERDES/PCS quads can be controlled by memory cells set during device configuration or by registers that are addressable during device operation. The registers in every quad can be programmed via the SERDES Client Interface (SCI). These quads (up to four) are located at the bottom of the devices.

Each PIC block encompasses two PIOs (PIO pairs) with their respective sysI/O buffers. The sysI/O buffers of the LatticeECP3 devices are arranged in seven banks, allowing the implementation of a wide variety of I/O standards. In addition, a separate I/O bank is provided for the programming interfaces. 50% of the PIO pairs on the left and right edges of the device can be configured as LVDS transmit/receive pairs. The PIC logic also includes pre-engineered support to aid in the implementation of high speed source synchronous standards such as XGMII, 7:1 LVDS, along with memory interfaces including DDR3.

Other blocks provided include PLLs, DLLs and configuration functions. The LatticeECP3 architecture provides two Delay Locked Loops (DLLs) and up to ten Phase Locked Loops (PLLs). In addition, each LatticeECP3 family member provides two DLLs per device. The PLL and DLL blocks are located at the end of the EBR/DSP rows.

The configuration block that supports features such as configuration bit-stream decryption, transparent updates and dual-boot support is located toward the center of this EBR row. Every device in the LatticeECP3 family supports a sysCONFIG™ port located in the corner between banks one and two, which allows for serial or parallel device configuration.

In addition, every device in the family has a JTAG port. This family also provides an on-chip oscillator and soft error detect capability. The LatticeECP3 devices use 1.2V as their core voltage.

Figure 2-1. Simplified Block Diagram, LatticeECP3-35 Device (Top Level)



Note: There is no Bank 4 or Bank 5 in LatticeECP3 devices.

PFU Blocks

The core of the LatticeECP3 device consists of PFU blocks, which are provided in two forms, the PFU and PFF. The PFUs can be programmed to perform Logic, Arithmetic, Distributed RAM and Distributed ROM functions. PFF blocks can be programmed to perform Logic, Arithmetic and ROM functions. Except where necessary, the remainder of this data sheet will use the term PFU to refer to both PFU and PFF blocks.

Each PFU block consists of four interconnected slices numbered 0-3 as shown in Figure 2-2. Each slice contains two LUTs. All the interconnections to and from PFU blocks are from routing. There are 50 inputs and 23 outputs associated with each PFU block.

Figure 2-2. PFU Diagram

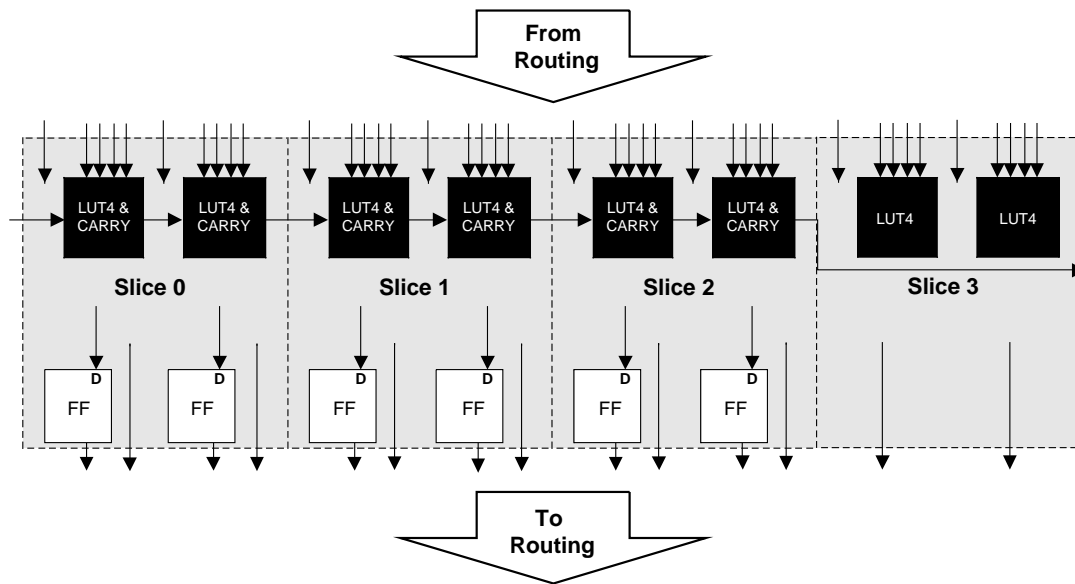

Slice

Slice 0 through Slice 2 contain two LUT4s feeding two registers, whereas Slice 3 contains two LUT4s only. For PFUs, Slice 0 through Slice 2 can be configured as distributed memory, a capability not available in the PFF. Table 2-1 shows the capability of the slices in both PFF and PFU blocks along with the operation modes they enable. In addition, each PFU contains logic that allows the LUTs to be combined to perform functions such as LUT5, LUT6, LUT7 and LUT8. There is control logic to perform set/reset functions (programmable as synchronous/asynchronous), clock select, chip-select and wider RAM/ROM functions.

Table 2-1. Resources and Modes Available per Slice

Slice	PFU BLock		PFF Block	
	Resources	Modes	Resources	Modes
Slice 0	2 LUT4s and 2 Registers	Logic, Ripple, RAM, ROM	2 LUT4s and 2 Registers	Logic, Ripple, ROM
Slice 1	2 LUT4s and 2 Registers	Logic, Ripple, RAM, ROM	2 LUT4s and 2 Registers	Logic, Ripple, ROM
Slice 2	2 LUT4s and 2 Registers	Logic, Ripple, RAM, ROM	2 LUT4s and 2 Registers	Logic, Ripple, ROM
Slice 3	2 LUT4s	Logic, ROM	2 LUT4s	Logic, ROM

Figure 2-3 shows an overview of the internal logic of the slice. The registers in the slice can be configured for positive/negative and edge triggered or level sensitive clocks.

Slices 0, 1 and 2 have 14 input signals: 13 signals from routing and one from the carry-chain (from the adjacent slice or PFU). There are seven outputs: six to routing and one to carry-chain (to the adjacent PFU). Slice 3 has 10 input signals from routing and four signals to routing. Table 2-2 lists the signals associated with Slice 0 to Slice 2.

Figure 2-3. Slice Diagram



* Not in Slice 3

For Slices 0 and 1, memory control signals are generated from Slice 2 as follows:
 WCK is CLK
 WRE is from LSR
 DI[3:2] for Slice 1 and DI[1:0] for Slice 0 data from Slice 2
 WAD [A:D] is a 4-bit address from slice 2 LUT input

Table 2-2. Slice Signal Descriptions

Function	Type	Signal Names	Description
Input	Data signal	A0, B0, C0, D0	Inputs to LUT4
Input	Data signal	A1, B1, C1, D1	Inputs to LUT4
Input	Multi-purpose	M0	Multipurpose Input
Input	Multi-purpose	M1	Multipurpose Input
Input	Control signal	CE	Clock Enable
Input	Control signal	LSR	Local Set/Reset
Input	Control signal	CLK	System Clock
Input	Inter-PFU signal	FC	Fast Carry-in ¹
Input	Inter-slice signal	FXA	Intermediate signal to generate LUT6 and LUT7
Input	Inter-slice signal	FXB	Intermediate signal to generate LUT6 and LUT7
Output	Data signals	F0, F1	LUT4 output register bypass signals
Output	Data signals	Q0, Q1	Register outputs
Output	Data signals	OFX0	Output of a LUT5 MUX
Output	Data signals	OFX1	Output of a LUT6, LUT7, LUT8 ² MUX depending on the slice
Output	Inter-PFU signal	FCO	Slice 2 of each PFU is the fast carry chain output ¹

1. See Figure 2-3 for connection details.

2. Requires two PFUs.

Modes of Operation

Each slice has up to four potential modes of operation: Logic, Ripple, RAM and ROM.

Logic Mode

In this mode, the LUTs in each slice are configured as 4-input combinatorial lookup tables. A LUT4 can have 16 possible input combinations. Any four input logic functions can be generated by programming this lookup table. Since there are two LUT4s per slice, a LUT5 can be constructed within one slice. Larger look-up tables such as LUT6, LUT7 and LUT8 can be constructed by concatenating other slices. Note LUT8 requires more than four slices.

Ripple Mode

Ripple mode supports the efficient implementation of small arithmetic functions. In ripple mode, the following functions can be implemented by each slice:

- Addition 2-bit
- Subtraction 2-bit
- Add/Subtract 2-bit using dynamic control
- Up counter 2-bit
- Down counter 2-bit
- Up/Down counter with asynchronous clear
- Up/Down counter with preload (sync)
- Ripple mode multiplier building block
- Multiplier support
- Comparator functions of A and B inputs
 - A greater-than-or-equal-to B
 - A not-equal-to B
 - A less-than-or-equal-to B

Ripple Mode includes an optional configuration that performs arithmetic using fast carry chain methods. In this configuration (also referred to as CCU2 mode) two additional signals, Carry Generate and Carry Propagate, are generated on a per slice basis to allow fast arithmetic functions to be constructed by concatenating Slices.

RAM Mode

In this mode, a 16x4-bit distributed single port RAM (SPR) can be constructed using each LUT block in Slice 0 and Slice 1 as a 16x1-bit memory. Slice 2 is used to provide memory address and control signals. A 16x2-bit pseudo dual port RAM (PDPR) memory is created by using one Slice as the read-write port and the other companion slice as the read-only port.

LatticeECP3 devices support distributed memory initialization.

The Lattice design tools support the creation of a variety of different size memories. Where appropriate, the software will construct these using distributed memory primitives that represent the capabilities of the PFU. Table 2-3 shows the number of slices required to implement different distributed RAM primitives. For more information about using RAM in LatticeECP3 devices, please see TN1179, [LatticeECP3 Memory Usage Guide](#).

Table 2-3. Number of Slices Required to Implement Distributed RAM

	SPR 16X4	PDPR 16X4
Number of slices	3	3

Note: SPR = Single Port RAM, PDPR = Pseudo Dual Port RAM

ROM Mode

ROM mode uses the LUT logic; hence, Slices 0 through 3 can be used in ROM mode. Preloading is accomplished through the programming interface during PFU configuration.

For more information, please refer to TN1179, [LatticeECP3 Memory Usage Guide](#).

Routing

There are many resources provided in the LatticeECP3 devices to route signals individually or as busses with related control signals. The routing resources consist of switching circuitry, buffers and metal interconnect (routing) segments.

The LatticeECP3 family has an enhanced routing architecture that produces a compact design. The ispLEVER design tool suite takes the output of the synthesis tool and places and routes the design.

sysCLOCK PLLs and DLLs

The sysCLOCK PLLs provide the ability to synthesize clock frequencies. All the devices in the LatticeECP3 family support four to ten full-featured General Purpose PLLs.

General Purpose PLL

The architecture of the PLL is shown in Figure 2-4. A description of the PLL functionality follows.

CLKI is the reference frequency (generated either from the pin or from routing) for the PLL. CLKI feeds into the Input Clock Divider block. The CLKFB is the feedback signal (generated from CLKOP, CLKOS or from a user clock pin/logic). This signal feeds into the Feedback Divider. The Feedback Divider is used to multiply the reference frequency.

Both the input path and feedback signals enter the Voltage Controlled Oscillator (VCO) block. In this block the difference between the input path and feedback signals is used to control the frequency and phase of the oscillator. A LOCK signal is generated by the VCO to indicate that the VCO has locked onto the input clock signal. In dynamic mode, the PLL may lose lock after a dynamic delay adjustment and not relock until the t_{LOCK} parameter has been satisfied.

The output of the VCO then enters the CLKOP divider. The CLKOP divider allows the VCO to operate at higher frequencies than the clock output (CLKOP), thereby increasing the frequency range. The Phase/Duty Select block adjusts the phase and duty cycle of the CLKOS signal. The phase/duty cycle setting can be pre-programmed or dynamically adjusted. A secondary divider takes the CLKOP or CLKOS signal and uses it to derive lower frequency outputs (CLKOK).

The primary output from the CLKOP divider (CLKOP) along with the outputs from the secondary dividers (CLKOK and CLKOK2) and Phase/Duty select (CLKOS) are fed to the clock distribution network.

The PLL allows two methods for adjusting the phase of signal. The first is referred to as Fine Delay Adjustment. This inserts up to 16 nominal 125ps delays to be applied to the secondary PLL output. The number of steps may be set statically or from the FPGA logic. The second method is referred to as Coarse Phase Adjustment. This allows the phase of the rising and falling edge of the secondary PLL output to be adjusted in 22.5 degree steps. The number of steps may be set statically or from the FPGA logic.

Figure 2-4. General Purpose PLL Diagram



Table 2-4 provides a description of the signals in the PLL blocks.

Table 2-4. PLL Blocks Signal Descriptions

Signal	I/O	Description
CLKI	I	Clock input from external pin or routing
CLKFB	I	PLL feedback input from CLKOP, CLKOS, or from a user clock (pin or logic)
RST	I	"1" to reset PLL counters, VCO, charge pumps and M-dividers
RSTK	I	"1" to reset K-divider
WRDEL	I	DPA Fine Delay Adjust input
CLKOS	O	PLL output to clock tree (phase shifted/duty cycle changed)
CLKOP	O	PLL output to clock tree (no phase shift)
CLKKOK	O	PLL output to clock tree through secondary clock divider
CLKKOK2	O	PLL output to clock tree (CLKOP divided by 3)
LOCK	O	"1" indicates PLL LOCK to CLKI
FDA [3:0]	I	Dynamic fine delay adjustment on CLKOS output
DRPAI[3:0]	I	Dynamic coarse phase shift, rising edge setting
DFPAI[3:0]	I	Dynamic coarse phase shift, falling edge setting

Delay Locked Loops (DLL)

In addition to PLLs, the LatticeECP3 family of devices has two DLLs per device.

CLKI is the input frequency (generated either from the pin or routing) for the DLL. CLKI feeds into the output muxes block to bypass the DLL, directly to the DELAY CHAIN block and (directly or through divider circuit) to the reference input of the Phase Detector (PD) input mux. The reference signal for the PD can also be generated from the Delay Chain signals. The feedback input to the PD is generated from the CLKFB pin or from a tapped signal from the Delay chain.

The PD produces a binary number proportional to the phase and frequency difference between the reference and feedback signals. Based on these inputs, the ALU determines the correct digital control codes to send to the delay

chain in order to better match the reference and feedback signals. This digital code from the ALU is also transmitted via the Digital Control bus (DCNTL) bus to its associated Slave Delay lines (two per DLL). The ALUHOLD input allows the user to suspend the ALU output at its current value. The UDDCNTL signal allows the user to latch the current value on the DCNTL bus.

The DLL has two clock outputs, CLKOP and CLKOS. These outputs can individually select one of the outputs from the tapped delay line. The CLKOS has optional fine delay shift and divider blocks to allow this output to be further modified, if required. The fine delay shift block allows the CLKOS output to phase shifted a further 45, 22.5 or 11.25 degrees relative to its normal position. Both the CLKOS and CLKOP outputs are available with optional duty cycle correction. Divide by two and divide by four frequencies are available at CLKOS. The LOCK output signal is asserted when the DLL is locked. Figure 2-5 shows the DLL block diagram and Table 2-5 provides a description of the DLL inputs and outputs.

The user can configure the DLL for many common functions such as time reference delay mode and clock injection removal mode. Lattice provides primitives in its design tools for these functions.

Figure 2-5. Delay Locked Loop Diagram (DLL)



* This signal is not user accessible. This can only be used to feed the slave delay line.

Table 2-5. DLL Signals

Signal	I/O	Description
CLKI	I	Clock input from external pin or routing
CLKFB	I	DLL feed input from DLL output, clock net, routing or external pin
RSTN	I	Active low synchronous reset
ALUHOLD	I	Active high freezes the ALU
UDDCNTL	I	Synchronous enable signal (hold high for two cycles) from routing
CLKOP	O	The primary clock output
CLKOS	O	The secondary clock output with one delay shift and/or division by 2 or by 4
LOCK	O	Active high phase lock indicator
INCI	I	Incremental indicator from another DLL via CIB.
GRAYI[5:0]	I	Gray-coded digital control bus from another DLL in time reference mode.
DIFF	O	Difference indicator when DCNTL is difference than the internal setting and update is needed.
INCO	O	Incremental indicator to other DLLs via CIB.
GRAYO[5:0]	O	Gray-coded digital control bus to other DLLs via CIB

LatticeECP3 devices have two general DLLs and four Slave Delay lines, two per DLL. The DLLs are in the lowest EBR row and located adjacent to the EBR. Each DLL replaces one EBR block. One Slave Delay line is placed adjacent to the DLL and the duplicate Slave Delay line (in Figure 2-6) for the DLL is placed in the I/O ring between Banks 6 and 7 and Banks 2 and 3.

The outputs from the DLL and Slave Delay lines are fed to the clock distribution network.

For more information, please see TN1178, [LatticeECP3 sysCLOCK PLL/DLL Design and Usage Guide](#).

Figure 2-6. Top-Level Block Diagram, High-Speed DLL and Slave Delay Line

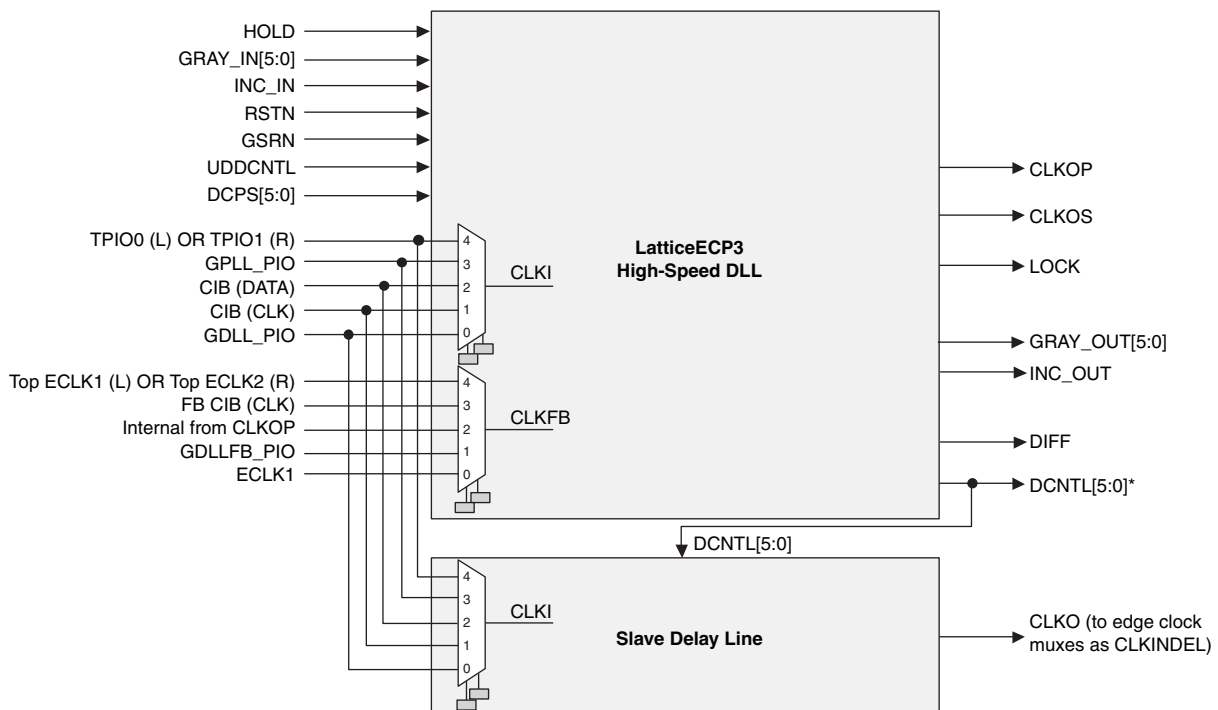

* This signal is not user accessible. It can only be used to feed the slave delay line.

PLL/DLL Cascading

LatticeECP3 devices have been designed to allow certain combinations of PLL and DLL cascading. The allowable combinations are:

- PLL to PLL supported
- PLL to DLL supported

The DLLs in the LatticeECP3 are used to shift the clock in relation to the data for source synchronous inputs. PLLs are used for frequency synthesis and clock generation for source synchronous interfaces. Cascading PLL and DLL blocks allows applications to utilize the unique benefits of both DLLs and PLLs.

For further information about the DLL, please see the list of technical documentation at the end of this data sheet.

PLL/DLL PIO Input Pin Connections

All LatticeECP3 devices contains two DLLs and up to ten PLLs, arranged in quadrants. If a PLL and a DLL are next to each other, they share input pins as shown in the Figure 2-7.

Figure 2-7. Sharing of PIO Pins by PLLs and DLLs in LatticeECP3 Devices



Note: Not every PLL has an associated DLL.

Clock Dividers

LatticeECP3 devices have two clock dividers, one on the left side and one on the right side of the device. These are intended to generate a slower-speed system clock from a high-speed edge clock. The block operates in a $\div 2$, $\div 4$ or $\div 8$ mode and maintains a known phase relationship between the divided down clock and the high-speed clock based on the release of its reset signal. The clock dividers can be fed from selected PLL/DLL outputs, the Slave Delay lines, routing or from an external clock input. The clock divider outputs serve as primary clock sources and feed into the clock distribution network. The Reset (RST) control signal resets input and asynchronously forces all outputs to low. The RELEASE signal releases outputs synchronously to the input clock. For further information on clock dividers, please see TN1178, [LatticeECP3 sysCLOCK PLL/DLL Design and Usage Guide](#). Figure 2-8 shows the clock divider connections.

Figure 2-8. Clock Divider Connections



Clock Distribution Network

LatticeECP3 devices have eight quadrant-based primary clocks and eight secondary clock/control sources. Two high performance edge clocks are available on the top, left, and right edges of the device to support high speed interfaces. These clock sources are selected from external I/Os, the sysCLOCK PLLs, DLLs or routing. These clock sources are fed throughout the chip via a clock distribution system.

Primary Clock Sources

LatticeECP3 devices derive clocks from six primary source types: PLL outputs, DLL outputs, CLKDIV outputs, dedicated clock inputs, routing and SERDES Quads. LatticeECP3 devices have two to ten sysCLOCK PLLs and two DLLs, located on the left and right sides of the device. There are six dedicated clock inputs: two on the top side, two on the left side and two on the right side of the device. Figures 2-9, 2-10 and 2-11 show the primary clock sources for LatticeECP3 devices.

Figure 2-9. Primary Clock Sources for LatticeECP3-17



Note: Clock inputs can be configured in differential or single-ended mode.

Figure 2-10. Primary Clock Sources for LatticeECP3-35



Figure 2-11. Primary Clock Sources for LatticeECP3-70, -95, -150



Primary Clock Routing

The purpose of the primary clock routing is to distribute primary clock sources to the destination quadrants of the device. A global primary clock is a primary clock that is distributed to all quadrants. The clock routing structure in LatticeECP3 devices consists of a network of eight primary clock lines (CLK0 through CLK7) per quadrant. The primary clocks of each quadrant are generated from muxes located in the center of the device. All the clock sources are connected to these muxes. Figure 2-12 shows the clock routing for one quadrant. Each quadrant mux is identical. If desired, any clock can be routed globally.

Figure 2-12. Per Quadrant Primary Clock Selection



Dynamic Clock Control (DCC)

The DCC (Quadrant Clock Enable/Disable) feature allows internal logic control of the quadrant primary clock network. When a clock network is disabled, all the logic fed by that clock does not toggle, reducing the overall power consumption of the device.

Dynamic Clock Select (DCS)

The DCS is a smart multiplexer function available in the primary clock routing. It switches between two independent input clock sources without any glitches or runt pulses. This is achieved regardless of when the select signal is toggled. There are two DCS blocks per quadrant; in total, there are eight DCS blocks per device. The inputs to the DCS block come from the center muxes. The output of the DCS is connected to primary clocks CLK6 and CLK7 (see Figure 2-12).

Figure 2-13 shows the timing waveforms of the default DCS operating mode. The DCS block can be programmed to other modes. For more information about the DCS, please see the list of technical documentation at the end of this data sheet.

Figure 2-13. DCS Waveforms



Secondary Clock/Control Sources

LatticeECP3 devices derive eight secondary clock sources (SC0 through SC7) from six dedicated clock input pads and the rest from routing. Figure 2-14 shows the secondary clock sources. All eight secondary clock sources are defined as inputs to a per-region mux SC0-SC7. SC0-SC3 are primary for control signals (CE and/or LSR), and SC4-SC7 are for clock and high fanout data.

In an actual implementation, there is some overlap to maximize routability. In addition to SC0-SC3, SC7 is also an input to the control signals (LSR or CE). SC0-SC2 are also inputs to clocks along with SC4-SC7. High fanout logic signals (LUT inputs) will utilize the X2 and X0 switches where SC0-SC7 are inputs to X2 switches, and SC4-SC7 are inputs to X0 switches. Note that through X0 switches, SC4-SC7 can also access control signals CE/LSR.

Figure 2-14. Secondary Clock Sources



Note: Clock inputs can be configured in differential or single-ended mode.

Secondary Clock/Control Routing

Global secondary clock is a secondary clock that is distributed to all regions. The purpose of the secondary clock routing is to distribute the secondary clock sources to the secondary clock regions. Secondary clocks in the LatticeECP3 devices are region-based resources. Certain EBR rows and special vertical routing channels bind the secondary clock regions. This special vertical routing channel aligns with either the left edge of the center DSP slice in the DSP row or the center of the DSP row. Figure 2-15 shows this special vertical routing channel and the 20 secondary clock regions for the LatticeECP3 family of devices. All devices in the LatticeECP3 family have eight

secondary clock resources per region (SC0 to SC7). The same secondary clock routing can be used for control signals.

Table 2-6. Secondary Clock Regions

Device	Number of Secondary Clock Regions
ECP3-17	16
ECP3-35	16
ECP3-70	20
ECP3-95	20
ECP3-150	36

Figure 2-15. LatticeECP3-70 and LatticeECP3-95 Secondary Clock Regions



Figure 2-16. Per Region Secondary Clock Selection



Slice Clock Selection

Figure 2-17 shows the clock selections and Figure 2-18 shows the control selections for Slice0 through Slice2. All the primary clocks and seven secondary clocks are routed to this clock selection mux. Other signals can be used as a clock input to the slices via routing. Slice controls are generated from the secondary clocks/controls or other signals connected via routing.

If none of the signals are selected for both clock and control then the default value of the mux output is 1. Slice 3 does not have any registers; therefore it does not have the clock or control muxes.

Figure 2-17. Slice0 through Slice2 Clock Selection



Figure 2-18. Slice0 through Slice2 Control Selection



Edge Clock Sources

Edge clock resources can be driven from a variety of sources at the same edge. Edge clock resources can be driven from adjacent edge clock PIOs, primary clock PIOs, PLLs, DLLs, Slave Delay and clock dividers as shown in Figure 2-19.

Figure 2-19. Edge Clock Sources

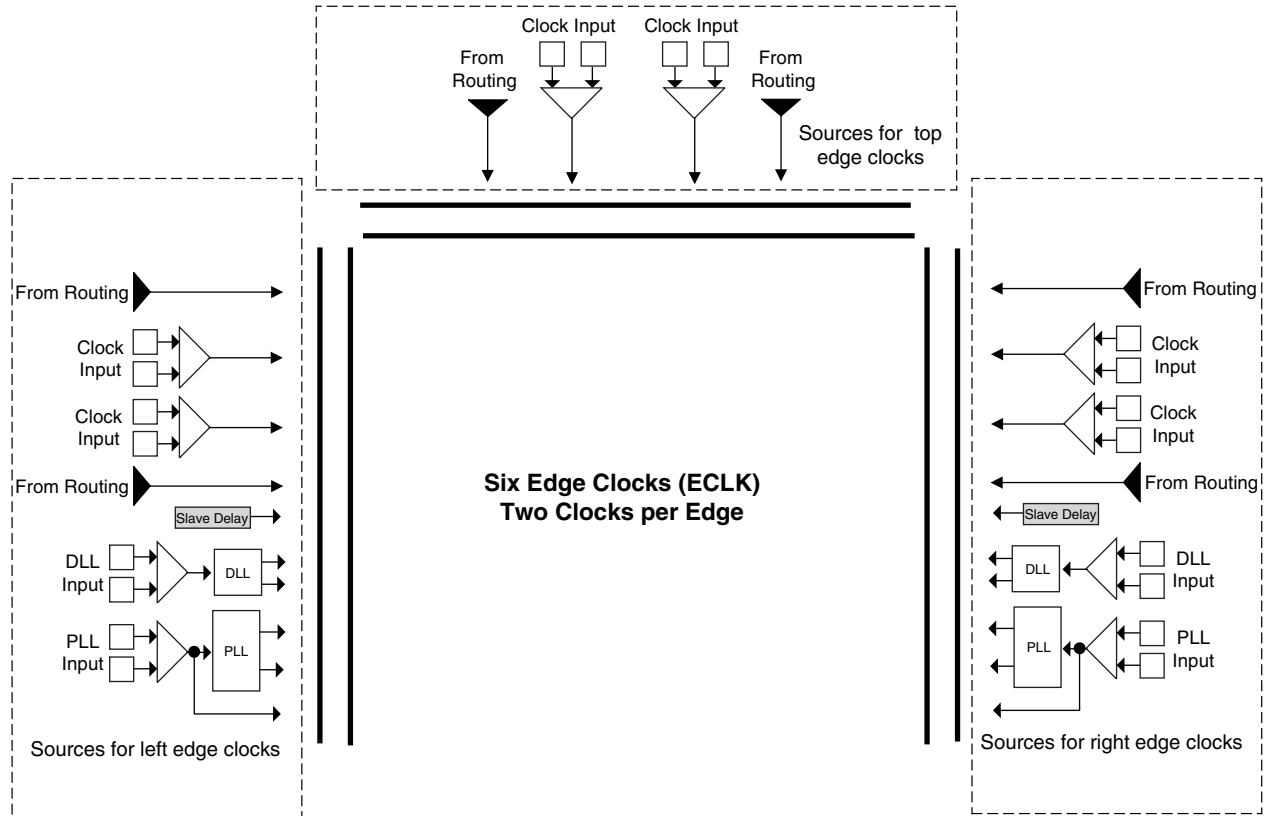

- Notes:
1. Clock inputs can be configured in differential or single ended mode.
 2. The two DLLs can also drive the two top edge clocks.
 3. The top left and top right PLL can also drive the two top edge clocks.

Edge Clock Routing

LatticeECP3 devices have a number of high-speed edge clocks that are intended for use with the PIOs in the implementation of high-speed interfaces. There are six edge clocks per device: two edge clocks on each of the top, left, and right edges. Different PLL and DLL outputs are routed to the two muxes on the left and right sides of the device. In addition, the CLKINDEL signal (generated from the DLL Slave Delay Line block) is routed to all the edge clock muxes on the left and right sides of the device. Figure 2-20 shows the selection muxes for these clocks.

Figure 2-20. Sources of Edge Clock (Left and Right Edges)



Figure 2-21. Sources of Edge Clock (Top Edge)



The edge clocks have low injection delay and low skew. They are used to clock the I/O registers and thus are ideal for creating I/O interfaces with a single clock signal and a wide data bus. They are also used for DDR Memory or Generic DDR interfaces.

The edge clocks on the top, left, and right sides of the device can drive the secondary clocks or general routing resources of the device. The left and right side edge clocks also can drive the primary clock network through the clock dividers (CLKDIV).

sysMEM Memory

LatticeECP3 devices contain a number of sysMEM Embedded Block RAM (EBR). The EBR consists of an 18-Kbit RAM with memory core, dedicated input registers and output registers with separate clock and clock enable. Each EBR includes functionality to support true dual-port, pseudo dual-port, single-port RAM, ROM and FIFO buffers (via external PFUs).

sysMEM Memory Block

The sysMEM block can implement single port, dual port or pseudo dual port memories. Each block can be used in a variety of depths and widths as shown in Table 2-7. FIFOs can be implemented in sysMEM EBR blocks by implementing support logic with PFUs. The EBR block facilitates parity checking by supporting an optional parity bit for each data byte. EBR blocks provide byte-enable support for configurations with 18-bit and 36-bit data widths. For more information, please see TN1179, [LatticeECP3 Memory Usage Guide](#).

Table 2-7. sysMEM Block Configurations

Memory Mode	Configurations
Single Port	16,384 x 1 8,192 x 2 4,096 x 4 2,048 x 9 1,024 x 18 512 x 36
True Dual Port	16,384 x 1 8,192 x 2 4,096 x 4 2,048 x 9 1,024 x 18
Pseudo Dual Port	16,384 x 1 8,192 x 2 4,096 x 4 2,048 x 9 1,024 x 18 512 x 36

Bus Size Matching

All of the multi-port memory modes support different widths on each of the ports. The RAM bits are mapped LSB word 0 to MSB word 0, LSB word 1 to MSB word 1, and so on. Although the word size and number of words for each port varies, this mapping scheme applies to each port.

RAM Initialization and ROM Operation

If desired, the contents of the RAM can be pre-loaded during device configuration. By preloading the RAM block during the chip configuration cycle and disabling the write controls, the sysMEM block can also be utilized as a ROM.

Memory Cascading

Larger and deeper blocks of RAM can be created using EBR sysMEM Blocks. Typically, the Lattice design tools cascade memory transparently, based on specific design inputs.

Single, Dual and Pseudo-Dual Port Modes

In all the sysMEM RAM modes the input data and address for the ports are registered at the input of the memory array. The output data of the memory is optionally registered at the output.

EBR memory supports the following forms of write behavior for single port or dual port operation:

1. **Normal** – Data on the output appears only during a read cycle. During a write cycle, the data (at the current address) does not appear on the output. This mode is supported for all data widths.
2. **Write Through** – A copy of the input data appears at the output of the same port during a write cycle. This mode is supported for all data widths.
3. **Read-Before-Write (EA devices only)** – When new data is written, the old content of the address appears at the output. This mode is supported for x9, x18, and x36 data widths.

Memory Core Reset

The memory array in the EBR utilizes latches at the A and B output ports. These latches can be reset asynchronously or synchronously. RSTA and RSTB are local signals, which reset the output latches associated with Port A and Port B, respectively. The Global Reset (GSRN) signal can reset both ports. The output data latches and associated resets for both ports are as shown in Figure 2-22.

Figure 2-22. Memory Core Reset



For further information on the sysMEM EBR block, please see the list of technical documentation at the end of this data sheet.

sysDSP™ Slice

The LatticeECP3 family provides an enhanced sysDSP architecture, making it ideally suited for low-cost, high-performance Digital Signal Processing (DSP) applications. Typical functions used in these applications are Finite Impulse Response (FIR) filters, Fast Fourier Transforms (FFT) functions, Correlators, Reed-Solomon/Turbo/Convolution encoders and decoders. These complex signal processing functions use similar building blocks such as multiply-adders and multiply-accumulators.

sysDSP Slice Approach Compared to General DSP

Conventional general-purpose DSP chips typically contain one to four (Multiply and Accumulate) MAC units with fixed data-width multipliers; this leads to limited parallelism and limited throughput. Their throughput is increased by higher clock speeds. The LatticeECP3, on the other hand, has many DSP slices that support different data widths.

This allows designers to use highly parallel implementations of DSP functions. Designers can optimize DSP performance vs. area by choosing appropriate levels of parallelism. Figure 2-23 compares the fully serial implementation to the mixed parallel and serial implementation.

Figure 2-23. Comparison of General DSP and LatticeECP3 Approaches



LatticeECP3 sysDSP Slice Architecture Features

The LatticeECP3 sysDSP Slice has been significantly enhanced to provide functions needed for advanced processing applications. These enhancements provide improved flexibility and resource utilization.

The LatticeECP3 sysDSP Slice supports many functions that include the following:

- Multiply (one 18x36, two 18x18 or four 9x9 Multiplies per Slice)
- Multiply (36x36 by cascading across two sysDSP slices)
- Multiply Accumulate (up to 18x36 Multipliers feeding an Accumulator that can have up to 54-bit resolution)
- Two Multiplies feeding one Accumulate per cycle for increased processing with lower latency (two 18x18 Multiplies feed into an accumulator that can accumulate up to 52 bits)
- Flexible saturation and rounding options to satisfy a diverse set of applications situations
- Flexible cascading across DSP slices
 - Minimizes fabric use for common DSP and ALU functions
 - Enables implementation of FIR Filter or similar structures using dedicated sysDSP slice resources only
 - Provides matching pipeline registers
 - Can be configured to continue cascading from one row of sysDSP slices to another for longer cascade chains
- Flexible and Powerful Arithmetic Logic Unit (ALU) Supports:
 - Dynamically selectable ALU OPCODE
 - Ternary arithmetic (addition/subtraction of three inputs)
 - Bit-wise two-input logic operations (AND, OR, NAND, NOR, XOR and XNOR)
 - Eight flexible and programmable ALU flags that can be used for multiple pattern detection scenarios, such

- as, overflow, underflow and convergent rounding, etc.
- Flexible cascading across slices to get larger functions
- RTL Synthesis friendly synchronous reset on all registers, while still supporting asynchronous reset for legacy users
- Dynamic MUX selection to allow Time Division Multiplexing (TDM) of resources for applications that require processor-like flexibility that enables different functions for each clock cycle

For most cases, as shown in Figure 2-24, the LatticeECP3 DSP slice is backwards-compatible with the LatticeECP2™ sysDSP block, such that, legacy applications can be targeted to the LatticeECP3 sysDSP slice. The functionality of one LatticeECP2 sysDSP Block can be mapped into two adjacent LatticeECP3 sysDSP slices, as shown in Figure 2-25.

Figure 2-24. Simplified sysDSP Slice Block Diagram



Figure 2-25. Detailed sysDSP Slice Diagram



Note: A_ALU, B_ALU and C_ALU are internal signals generated by combining bits from AA, AB, BA BB and C inputs. See TN1182, LatticeECP3 sysDSP Usage Guide, for further information.

The LatticeECP2 sysDSP block supports the following basic elements.

- MULT (Multiply)
- MAC (Multiply, Accumulate)
- MULTADDSUB (Multiply, Addition/Subtraction)
- MULTADDSUBSUM (Multiply, Addition/Subtraction, Summation)

Table 2-8 shows the capabilities of each of the LatticeECP3 slices versus the above functions.

Table 2-8. Maximum Number of Elements in a Slice

Width of Multiply	x9	x18	x36
MULT	4	2	1/2
MAC	1	1	—
MULTADDSUB	2	1	—
MULTADDSUBSUM	1 ¹	1/2	—

1. One slice can implement 1/2 9x9 m9x9addsubsum and two m9x9addsubsum with two slices.

Some options are available in the four elements. The input register in all the elements can be directly loaded or can be loaded as a shift register from previous operand registers. By selecting “dynamic operation” the following operations are possible:

- In the Add/Sub option the Accumulator can be switched between addition and subtraction on every cycle.
- The loading of operands can switch between parallel and serial operations.

For further information, please refer to TN1182, [LatticeECP3 sysDSP Usage Guide](#).

MULT DSP Element

This multiplier element implements a multiply with no addition or accumulator nodes. The two operands, AA and AB, are multiplied and the result is available at the output. The user can enable the input/output and pipeline registers. Figure 2-26 shows the MULT sysDSP element.

Figure 2-26. MULT sysDSP Element



MAC DSP Element

In this case, the two operands, AA and AB, are multiplied and the result is added with the previous accumulated value. This accumulated value is available at the output. The user can enable the input and pipeline registers, but the output register is always enabled. The output register is used to store the accumulated value. The ALU is configured as the accumulator in the sysDSP slice in the LatticeECP3 family can be initialized dynamically. A registered overflow signal is also available. The overflow conditions are provided later in this document. Figure 2-27 shows the MAC sysDSP element.

Figure 2-27. MAC DSP Element



MMAC DSP Element

The LatticeECP3 supports a MAC with two multipliers. This is called Multiply Multiply Accumulate or MMAC. In this case, the two operands, AA and AB, are multiplied and the result is added with the previous accumulated value and with the result of the multiplier operation of operands BA and BB. This accumulated value is available at the output. The user can enable the input and pipeline registers, but the output register is always enabled. The output register is used to store the accumulated value. The ALU is configured as the accumulator in the sysDSP slice. A registered overflow signal is also available. The overflow conditions are provided later in this document. Figure 2-28 shows the MMAC sysDSP element.

Figure 2-28. MMAC sysDSP Element

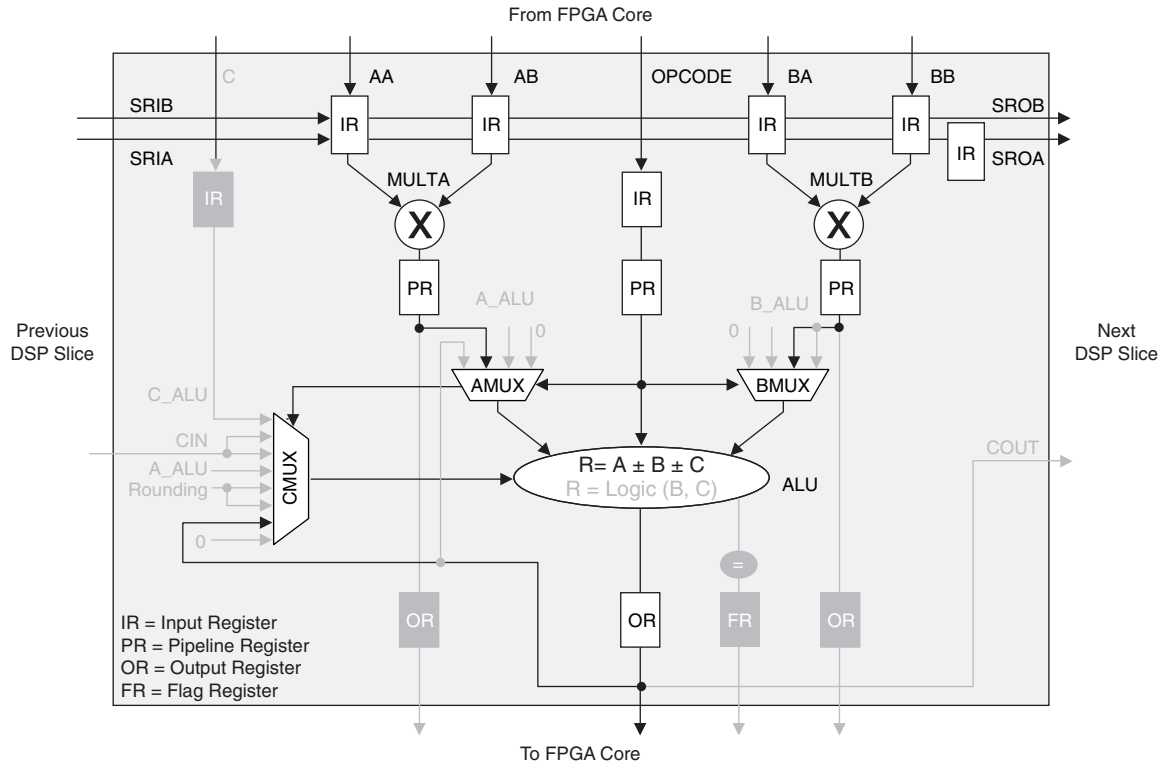

MULTADDSUB DSP Element

In this case, the operands AA and AB are multiplied and the result is added/subtracted with the result of the multiplier operation of operands BA and BB. The user can enable the input, output and pipeline registers. Figure 2-29 shows the MULTADDSUB sysDSP element.

Figure 2-29. MULTADDSUB



MULTADDSUBSUM DSP Element

In this case, the operands AA and AB are multiplied and the result is added/subtracted with the result of the multiplier operation of operands BA and BB of Slice 0. Additionally, the operands AA and AB are multiplied and the result is added/subtracted with the result of the multiplier operation of operands BA and BB of Slice 1. The results of both addition/subtractions are added by the second ALU following the slice cascade path. The user can enable the input, output and pipeline registers. Figure 2-30 and Figure 2-31 show the MULTADDSUBSUM sysDSP element.

Figure 2-30. MULTADDSUBSUM Slice 0



Figure 2-31. MULTADDSUBSUM Slice 1



Advanced sysDSP Slice Features

Cascading

The LatticeECP3 sysDSP slice has been enhanced to allow cascading. Adder trees are implemented fully in sysDSP slices, improving the performance. Cascading of slices uses the signals CIN, COUT and C Mux of the slice.

Addition

The LatticeECP3 sysDSP slice allows for the bypassing of multipliers and cascading of adder logic. High performance adder functions are implemented without the use of LUTs. The maximum width adders that can be implemented are 54-bit.

Rounding

The rounding operation is implemented in the ALU and is done by adding a constant followed by a truncation operation. The rounding methods supported are:

- Rounding to zero (RTZ)
- Rounding to infinity (RTI)
- Dynamic rounding
- Random rounding
- Convergent rounding

ALU Flags

The sysDSP slice provides a number of flags from the ALU including:

- Equal to zero (EQZ)
- Equal to zero with mask (EQZM)
- Equal to one with mask (EQOM)
- Equal to pattern with mask (EQPAT)
- Equal to bit inverted pattern with mask (EQPATB)
- Accumulator Overflow (OVER)
- Accumulator Underflow (UNDER)
- Either over or under flow supporting LatticeECP2 legacy designs (OVERUNDER)

Clock, Clock Enable and Reset Resources

Global Clock, Clock Enable and Reset signals from routing are available to every sysDSP slice. From four clock sources (CLK0, CLK1, CLK2, and CLK3) one clock is selected for each input register, pipeline register and output register. Similarly Clock Enable (CE) and Reset (RST) are selected at each input register, pipeline register and output register.

Resources Available in the LatticeECP3 Family

Table 2-9 shows the maximum number of multipliers for each member of the LatticeECP3 family. Table 2-10 shows the maximum available EBR RAM Blocks in each LatticeECP3 device. EBR blocks, together with Distributed RAM can be used to store variables locally for fast DSP operations.

Table 2-9. Maximum Number of DSP Slices in the LatticeECP3 Family

Device	DSP Slices	9x9 Multiplier	18x18 Multiplier	36x36 Multiplier
ECP3-17	12	48	24	6
ECP3-35	32	128	64	16
ECP3-70	64	256	128	32
ECP3-95	64	256	128	32
ECP3-150	160	640	320	80

Table 2-10. Embedded SRAM in the LatticeECP3 Family

Device	EBR SRAM Block	Total EBR SRAM (Kbits)
ECP3-17	38	700
ECP3-35	72	1327
ECP3-70	240	4420
ECP3-95	240	4420
ECP3-150	372	6850

Programmable I/O Cells (PIC)

Each PIC contains two PIOs connected to their respective sysI/O buffers as shown in Figure 2-32. The PIO Block supplies the output data (DO) and the tri-state control signal (TO) to the sysI/O buffer and receives input from the buffer. Table 2-11 provides the PIO signal list.

Figure 2-32. PIC Diagram



* Signals are available on left/right/top edges only.
 ** Signals are available on the left and right sides only
 *** Selected PIO.

Two adjacent PIOs can be joined to provide a differential I/O pair (labeled as “T” and “C”) as shown in Figure 2-32. The PAD Labels “T” and “C” distinguish the two PIOs. Approximately 50% of the PIO pairs on the left and right edges of the device can be configured as true LVDS outputs. All I/O pairs can operate as LVDS inputs.

Table 2-11. PIO Signal List

Name	Type	Description
INDD	Input Data	Register bypassed input. This is not the same port as INCK.
IPA, INA, IPB, INB	Input Data	Ports to core for input data
OPOSA, ONEGA ¹ , OPOSB, ONEGB ¹	Output Data	Output signals from core. An exception is the ONEGB port, used for tristate logic at the DQS pad.
CE	PIO Control	Clock enables for input and output block flip-flops.
SCLK	PIO Control	System Clock (PCLK) for input and output/TS blocks. Connected from clock ISB.
LSR	PIO Control	Local Set/Reset
ECLK1, ECLK2	PIO Control	Edge clock sources. Entire PIO selects one of two sources using mux.
ECLKDQSR ¹	Read Control	From DQS_STROBE, shifted strobe for memory interfaces only.
DDRCLKPOL ¹	Read Control	Ensures transfer from DQS domain to SCLK domain.
DDRLAT ¹	Read Control	Used to guarantee INDDR2 gearing by selectively enabling a D-Flip-Flop in datapath.
DEL[3:0]	Read Control	Dynamic input delay control bits.
INCK	To Clock Distribution and PLL	PIO treated as clock PIO, path to distribute to primary clocks and PLL.
TS	Tristate Data	Tristate signal from core (SDR)
DQCLK0 ¹ , DQCLK1 ¹	Write Control	Two clocks edges, 90 degrees out of phase, used in output gearing.
DQSW ²	Write Control	Used for output and tristate logic at DQS only.
DYNDEL[7:0]	Write Control	Shifting of write clocks for specific DQS group, using 6:0 each step is approximately 25ps, 128 steps. Bit 7 is an invert (timing depends on input frequency). There is also a static control for this 8-bit setting, enabled with a memory cell.
DCNTL[6:0]	PIO Control	Original delay code from DDR DLL
DATAVALID ¹	Output Data	Status flag from DATAVALID logic, used to indicate when input data is captured in IOLOGIC and valid to core.
READ	For DQS_Strobe	Read signal for DDR memory interface
DQSI	For DQS_Strobe	Unshifted DQS strobe from input pad
PRMBDET	For DQS_Strobe	DQSI biased to go high when DQSI is tristate, goes to input logic block as well as core logic.
GSRN	Control from routing	Global Set/Reset

1. Signals available on left/right/top edges only.

2. Selected PIO.

PIO

The PIO contains four blocks: an input register block, output register block, tristate register block and a control logic block. These blocks contain registers for operating in a variety of modes along with the necessary clock and selection logic.

Input Register Block

The input register blocks for the PIOs, in the left, right and top edges, contain delay elements and registers that can be used to condition high-speed interface signals, such as DDR memory interfaces and source synchronous interfaces, before they are passed to the device core. Figure 2-33 shows the input register block for the left, right and top edges. The input register block for the bottom edge contains one element to register the input signal and no DDR registers. The following description applies to the input register block for PIOs in the left, right and top edges only.

Input signals are fed from the sysI/O buffer to the input register block (as signal DI). If desired, the input signal can bypass the register and delay elements and be used directly as a combinatorial signal (INDD), a clock (INCK) and, in selected blocks, the input to the DQS delay block. If an input delay is desired, designers can select either a fixed delay or a dynamic delay DEL[3:0]. The delay, if selected, reduces input register hold time requirements when using a global clock.

The input block allows three modes of operation. In single data rate (SDR) the data is registered with the system clock by one of the registers in the single data rate sync register block.

In DDR mode, two registers are used to sample the data on the positive and negative edges of the modified DQS (ECLKDQSR) in the DDR Memory mode or ECLK signal when using DDR Generic mode, creating two data streams. Before entering the core, these two data streams are synchronized to the system clock to generate two data streams.

A gearbox function can be implemented in each of the input registers on the left and right sides. The gearbox function takes a double data rate signal applied to PIOA and converts it as four data streams, INA, IPA, INB and IPB. The two data streams from the first set of DDR registers are synchronized to the edge clock and then to the system clock before entering the core. Figure 2-30 provides further information on the use of the gearbox function.

The signal DDRCLKPOL controls the polarity of the clock used in the synchronization registers. It ensures adequate timing when data is transferred to the system clock domain from the ECLKDQSR (DDR Memory Interface mode) or ECLK (DDR Generic mode). The DDRLAT signal is used to ensure the data transfer from the synchronization registers to the clock transfer and gearbox registers.

The ECLKDQSR, DDRCLKPOL and DDRLAT signals are generated in the DQS Read Control Logic Block. See Figure 2-37 for an overview of the DQS read control logic.

Further discussion about using the DQS strobe in this module is discussed in the DDR Memory section of this data sheet.

Please see TN1180, [LatticeECP3 High-Speed I/O Interface](#) for more information on this topic.

Figure 2-33. ECP3-70/95 (E or EA) Input Register Block for Left, Right and Top Edges



* Only on the left and right sides.
 ** Selected PIO.
 Note: Simplified diagram does not show CE/SET/REST details.

Output Register Block

The output register block registers signals from the core of the device before they are passed to the sysIO buffers. The blocks on the left and right PIOs contain registers for SDR and full DDR operation. The topside PIO block is the same as the left and right sides except it does not support ODDR2 gearing of output logic. ODDR2 gearing is used in DDR3 memory interfaces. The PIO blocks on the bottom contain the SDR registers and generic DDR interface without gearing.

Figure 2-34 shows the Output Register Block for PIOs on the left and right edges.

In SDR mode, OPOSA feeds one of the flip-flops that then feeds the output. The flip-flop can be configured as a Dtype or latch. In DDR mode, two of the inputs are fed into registers on the positive edge of the clock. At the next clock cycle, one of the registered outputs is also latched.

A multiplexer running off the same clock is used to switch the mux between the 11 and 01 inputs that will then feed the output.

A gearbox function can be implemented in the output register block that takes four data streams: OPOSA, ONEGA, OPOSB and ONEGB. All four data inputs are registered on the positive edge of the system clock and two of them are also latched. The data is then output at a high rate using a multiplexer that runs off the DQCLK0 and DQCLK1 clocks. DQCLK0 and DQCLK1 are used in this case to transfer data from the system clock to the edge clock domain. These signals are generated in the DQS Write Control Logic block. See Figure 2-37 for an overview of the DQS write control logic.

Please see TN1180, [LatticeECP3 High-Speed I/O Interface](#) for more information on this topic.

Further discussion on using the DQS strobe in this module is discussed in the DDR Memory section of this data sheet.

Figure 2-34. ECP3-70/95 (E or EA) Output and Tristate Block for Left and Right Edges

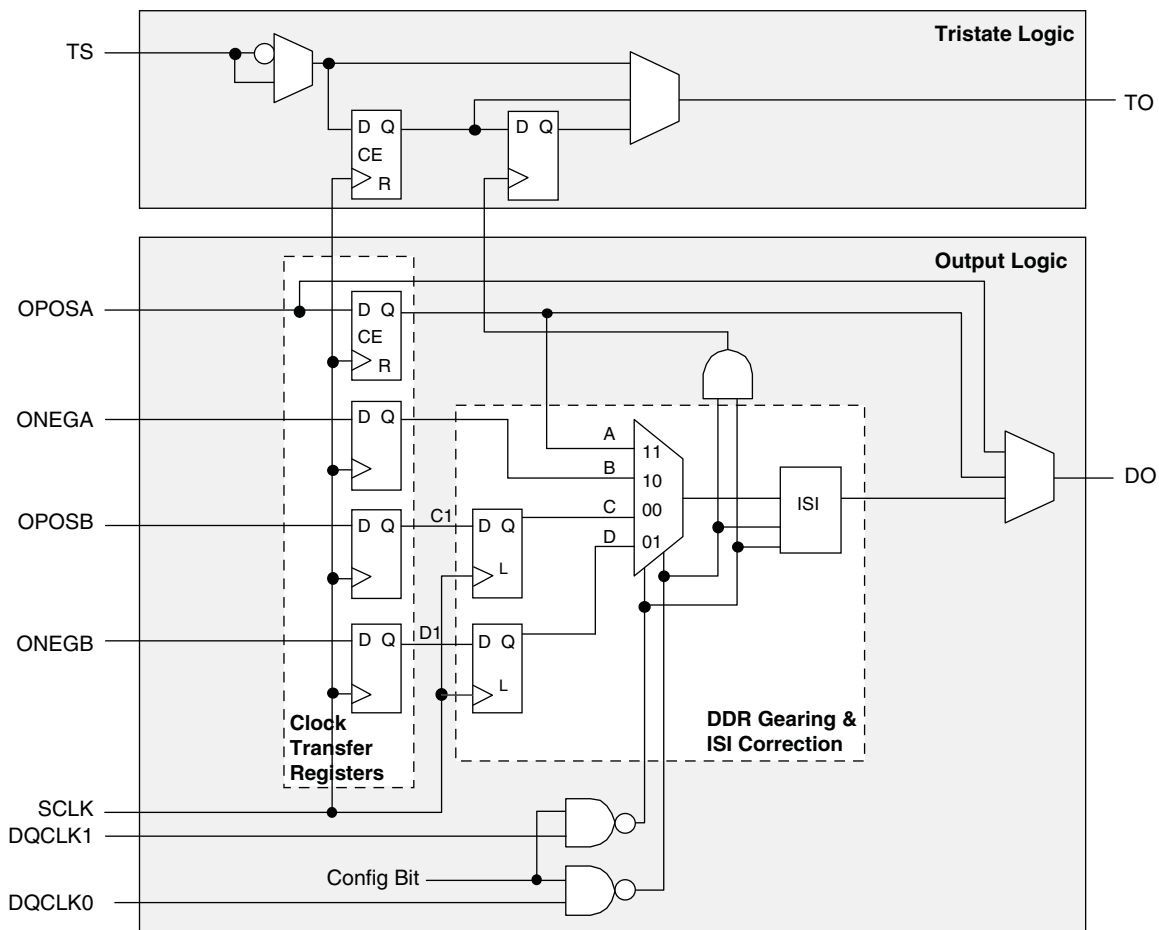

Tristate Register Block

The tristate register block registers tri-state control signals from the core of the device before they are passed to the sysI/O buffers. The block contains a register for SDR operation and an additional register for DDR operation.

In SDR and non-gearing DDR modes, TS input feeds one of the flip-flops that then feeds the output. In DDRX2 mode, the register TS input is fed into another register that is clocked using the DQCLK0 and DQCLK1 signals. The output of this register is used as a tristate control.

ISI Calibration

The setting for Inter-Symbol Interference (ISI) cancellation occurs in the output register block. ISI correction is only available in the DDRX2 modes. ISI calibration settings exist once per output register block, so each I/O in a DQS-12 group may have a different ISI calibration setting.

The ISI block extends output signals at certain times, as a function of recent signal history. So, if the output pattern consists of a long strings of 0's to long strings of 1's, there are no delays on output signals. However, if there are quick, successive transitions from 010, the block will stretch out the binary 1. This is because the long trail of 0's will cause these symbols to interfere with the logic 1. Likewise, if there are quick, successive transitions from 101, the block will stretch out the binary 0. This block is controlled by a 3-bit delay control that can be set in the DQS control logic block.

For more information about this topic, please see the list of technical documentation at the end of this data sheet.

Control Logic Block

The control logic block allows the selection and modification of control signals for use in the PIO block.

DDR Memory Support

Certain PICs have additional circuitry to allow the implementation of high-speed source synchronous and DDR1, DDR2 and DDR3 memory interfaces. The support varies by the edge of the device as detailed below.

Left and Right Edges

The left and right sides of the PIC have fully functional elements supporting DDR1, DDR2, and DDR3 memory interfaces. One of every 12 PIOs supports the dedicated DQS pins with the DQS control logic block. Figure 2-35 shows the DQS bus spanning 11 I/O pins. Two of every 12 PIOs support the dedicated DQS and DQS# pins with the DQS control logic block.

Bottom Edge

PICs on the bottom edge of the device do not support DDR memory and Generic DDR interfaces.

Top Edge

PICs on the top side are similar to the PIO elements on the left and right sides but do not support gearing on the output registers. Hence, the modes to support output/tristate DDR3 memory are removed on the top side.

The exact DQS pins are shown in a dual function in the Logic Signal Connections table in this data sheet. Additional detail is provided in the Signal Descriptions table. The DQS signal from the bus is used to strobe the DDR data from the memory into input register blocks. Interfaces on the left, right and top edges are designed for DDR memories that support 10 bits of data.

Figure 2-35. DQS Grouping on the Left, Right and Top Edges



DLL Calibrated DQS Delay Block

Source synchronous interfaces generally require the input clock to be adjusted in order to correctly capture data at the input register. For most interfaces, a PLL is used for this adjustment. However, in DDR memories the clock

(referred to as DQS) is not free-running so this approach cannot be used. The DQS Delay block provides the required clock alignment for DDR memory interfaces.

The delay required for the DQS signal is generated by two dedicated DLLs (DDR DLL) on opposite side of the device. Each DLL creates DQS delays in its half of the device as shown in Figure 2-36. The DDR DLL on the left side will generate delays for all the DQS Strobe pins on Banks 0, 7 and 6 and DDR DLL on the right will generate delays for all the DQS pins on Banks 1, 2 and 3. The DDR DLL loop compensates for temperature, voltage and process variations by using the system clock and DLL feedback loop. DDR DLL communicates the required delay to the DQS delay block using a 7-bit calibration bus (DCNTL[6:0])

The DQS signal (selected PIOs only, as shown in Figure 2-35) feeds from the PAD through a DQS control logic block to a dedicated DQS routing resource. The DQS control logic block consists of DQS Read Control logic block that generates control signals for the read side and DQS Write Control logic that generates the control signals required for the write side. A more detailed DQS control diagram is shown in Figure 2-37, which shows how the DQS control blocks interact with the data paths.

The DQS Read control logic receives the delay generated by the DDR DLL on its side and delays the incoming DQS signal by 90 degrees. This delayed ECLKDQSR is routed to 10 or 11 DQ pads covered by that DQS signal. This block also contains a polarity control logic that generates a DDRCLKPOL signal, which controls the polarity of the clock to the sync registers in the input register blocks. The DQS Read control logic also generates a DDRLAT signal that is in the input register block to transfer data from the first set of DDR register to the second set of DDR registers when using the DDRX2 gearbox mode for DDR3 memory interface.

The DQS Write control logic block generates the DQCLK0 and DQCLK1 clocks used to control the output gearing in the Output register block which generates the DDR data output and the DQS output. They are also used to control the generation of the DQS output through the DQS output register block. In addition to the DCNTL [6:0] input from the DDR DLL, the DQS Write control block also uses a Dynamic Delay DYN DEL [7:0] attribute which is used to further delay the DQS to accomplish the write leveling found in DDR3 memory. Write leveling is controlled by the DDR memory controller implementation. The DYN DELAY can set 128 possible delay step settings. In addition, the most significant bit will invert the clock for a 180-degree shift of the incoming clock. This will generate the DQSW signal used to generate the DQS output in the DQS output register block.

Figure 2-36 and Figure 2-37 show how the DQS transition signals that are routed to the PIOs.

Please see TN1180, [LatticeECP3 High-Speed I/O Interface](#) for more information on this topic.

Figure 2-36. Edge Clock, DLL Calibration and DQS Local Bus Distribution



*Includes shared configuration I/Os and dedicated configuration I/Os.

Figure 2-37. DQS Local Bus

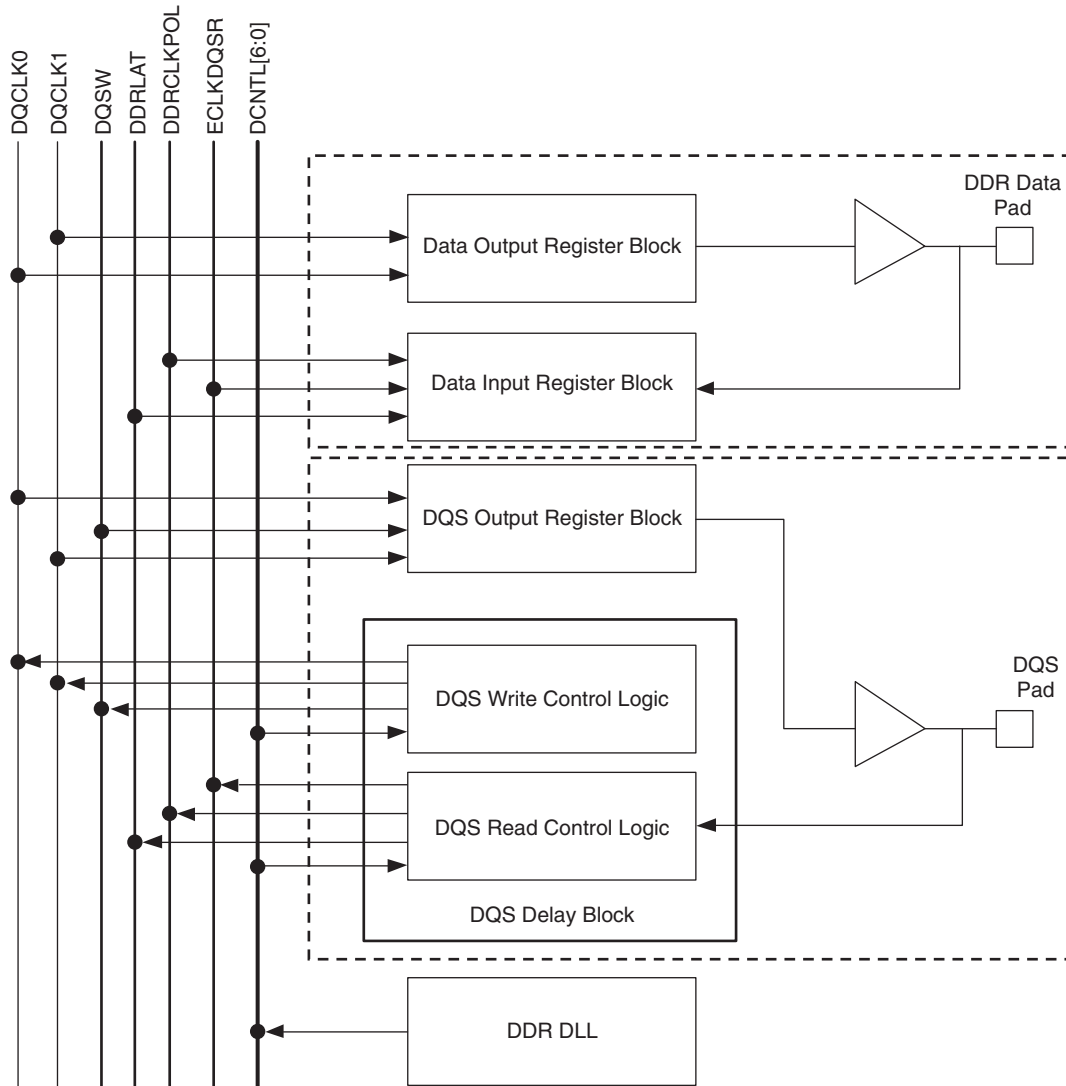

Polarity Control Logic

In a typical DDR Memory interface design, the phase relationship between the incoming delayed DQS strobe and the internal system clock (during the READ cycle) is unknown. The LatticeECP3 family contains dedicated circuits to transfer data between these domains. A clock polarity selector is used to prevent set-up and hold violations at the domain transfer between DQS (delayed) and the system clock. This changes the edge on which the data is registered in the synchronizing registers in the input register block. This requires evaluation at the start of each READ cycle for the correct clock polarity.

Prior to the READ operation in DDR memories, DQS is in tristate (pulled by termination). The DDR memory device drives DQS low at the start of the preamble state. A dedicated circuit detects the first DQS rising edge after the preamble state. This signal is used to control the polarity of the clock to the synchronizing registers.

DDR3 Memory Support

LatticeECP3 supports the read and write leveling required for DDR3 memory interfaces.

Read leveling is supported by the use of the DDRCLKPOL and the DDRLAT signals generated in the DQS Read Control logic block. These signals dynamically control the capture of the data with respect to the DQS at the input register block.

To accomplish write leveling in DDR3, each DQS group has a slightly different delay that is set by DYN DELAY[7:0] in the DQS Write Control logic block. The DYN DELAY can set 128 possible delay step settings. In addition, the most significant bit will invert the clock for a 180-degree shift of the incoming clock.

LatticeECP3 input and output registers can also support DDR gearing that is used to receive and transmit the high speed DDR data from and to the DDR3 Memory.

LatticeECP3 supports the 1.5V SSTL I/O standard required for the DDR3 memory interface. In addition, it supports on-chip termination to VTT on the DDR3 memory input pins. For more information, refer to the sysIO section of this data sheet.

Please see TN1180, [LatticeECP3 High-Speed I/O Interface](#) for more information on DDR Memory interface implementation in LatticeECP3.

sysI/O Buffer

Each I/O is associated with a flexible buffer referred to as a sysI/O buffer. These buffers are arranged around the periphery of the device in groups referred to as banks. The sysI/O buffers allow users to implement the wide variety of standards that are found in today's systems including LVDS, BLVDS, HSTL, SSTL Class I & II, LVCMOS, LVTTL, LVPECL, PCI.

sysI/O Buffer Banks

LatticeECP3 devices have six sysI/O buffer banks: six banks for user I/Os arranged two per side. The banks on the bottom side are wraparounds of the banks on the lower right and left sides. The seventh sysI/O buffer bank (Configuration Bank) is located adjacent to Bank 2 and has dedicated/shared I/Os for configuration. When a shared pin is not used for configuration it is available as a user I/O. Each bank is capable of supporting multiple I/O standards. Each sysI/O bank has its own I/O supply voltage (V_{CCIO}). In addition, each bank, except the Configuration Bank, has voltage references, V_{REF1} and V_{REF2} , which allow it to be completely independent from the others. The Configuration Bank top side shares V_{REF1} and V_{REF2} from sysI/O bank 1 and right side shares V_{REF1} and V_{REF2} from sysI/O bank 2. Figure 2-38 shows the seven banks and their associated supplies.

In LatticeECP3 devices, single-ended output buffers and ratioed input buffers (LVTTL, LVCMOS and PCI) are powered using V_{CCIO} . LVTTL, LVCMOS33, LVCMOS25 and LVCMOS12 can also be set as fixed threshold inputs independent of V_{CCIO} .

Each bank can support up to two separate V_{REF} voltages, V_{REF1} and V_{REF2} , that set the threshold for the referenced input buffers. Some dedicated I/O pins in a bank can be configured to be a reference voltage supply pin. Each I/O is individually configurable based on the bank's supply and reference voltages.

Figure 2-38. LatticeECP3 Banks



LatticeECP3 devices contain two types of sysI/O buffer pairs.

1. **Top (Bank 0 and Bank 1) and Bottom sysI/O Buffer Pairs (Single-Ended Outputs Only)**

The sysI/O buffer pairs in the top banks of the device consist of two single-ended output drivers and two sets of single-ended input buffers (both ratioed and referenced). One of the referenced input buffers can also be configured as a differential input. Only the top edge buffers have a programmable PCI clamp.

The two pads in the pair are described as “true” and “comp”, where the true pad is associated with the positive side of the differential input buffer and the comp (complementary) pad is associated with the negative side of the differential input buffer.

On the top and bottom sides, there is no support for programmable on-chip input termination, which is required for DQ and DQS pins for DDR3 interface. This side is ideal for ADDR/CMD signals of DDR3, general purpose I/O, PCI, TR-LVDS (transition reduced LVDS) or LVDS inputs. Only the top I/O banks support hot socketing with I_{DK} specified under the Hot Socketing Specifications. The configuration bank is not hot-socketable.

2. Left and Right (Banks 2, 3, 6 and 7) sysI/O Buffer Pairs (50% Differential and 100% Single-Ended Outputs)

The sysI/O buffer pairs in the left and right banks of the device consist of two single-ended output drivers, two sets of single-ended input buffers (both ratioed and referenced) and one differential output driver. One of the referenced input buffers can also be configured as a differential input. In these banks the two pads in the pair are described as “true” and “comp”, where the true pad is associated with the positive side of the differential I/O, and the comp (complementary) pad is associated with the negative side of the differential I/O.

In addition, programmable on-chip input termination (parallel or differential, static or dynamic) is supported on these sides, which is required for DDR3 interface. However, there is no support for hot-socketing on these sides as the clamp is always present.

LVDS, RSDS, PPLVDS and Mini-LVDS differential output drivers are available on 50% of the buffer pairs on the left and right banks.

3. Configuration Bank sysI/O Buffer Pairs (Single-Ended Outputs, Only on Shared Pins When Not Used by Configuration)

The sysI/O buffers in the Configuration Bank consist of single-ended output drivers and single-ended input buffers (both ratioed and referenced). The referenced input buffer can also be configured as a differential input.

The two pads in the pair are described as “true” and “comp”, where the true pad is associated with the positive side of the differential input buffer and the comp (complementary) pad is associated with the negative side of the differential input buffer.

Programmable PCI clamps are only available on top banks (PCI clamps are used primarily on inputs and bidirectional pads to reduce ringing on the receiving end) can also be used on inputs.

Typical sysI/O I/O Behavior During Power-up

The internal power-on-reset (POR) signal is deactivated when V_{CC} , V_{CCIO8} and V_{CCAUX} have reached satisfactory levels. After the POR signal is deactivated, the FPGA core logic becomes active. It is the user's responsibility to ensure that all other V_{CCIO} banks are active with valid input logic levels to properly control the output logic states of all the I/O banks that are critical to the application. For more information about controlling the output logic state with valid input logic levels during power-up in LatticeECP3 devices, see the list of technical documentation at the end of this data sheet.

The V_{CC} and V_{CCAUX} supply the power to the FPGA core fabric, whereas the V_{CCIO} supplies power to the I/O buffers. In order to simplify system design while providing consistent and predictable I/O behavior, it is recommended that the I/O buffers be powered-up prior to the FPGA core fabric. V_{CCIO} supplies should be powered-up before or together with the V_{CC} and V_{CCAUX} supplies.

Supported sysI/O Standards

The LatticeECP3 sysI/O buffer supports both single-ended and differential standards. Single-ended standards can be further subdivided into LVCMOS, LVTTTL and other standards. The buffers support the LVTTTL, LVCMOS 1.2V, 1.5V, 1.8V, 2.5V and 3.3V standards. In the LVCMOS and LVTTTL modes, the buffer has individual configuration options for drive strength, slew rates, bus maintenance (weak pull-up, weak pull-down, or a bus-keeper latch) and open drain. Other single-ended standards supported include SSTL and HSTL. Differential standards supported include LVDS, BLVDS, LVPECL, MLVDS, RSDS, Mini-LVDS, PPLVDS (point-to-point LVDS), TRLVDS (Transition Reduced LVDS), differential SSTL and differential HSTL. Tables 2-13 and 2-14 show the I/O standards (together with their supply and reference voltages) supported by LatticeECP3 devices. For further information on utilizing the sysI/O buffer to support a variety of standards please see TN1177, [LatticeECP3 sysI/O Usage Guide](#).

On-Chip Programmable Termination

The LatticeECP3 supports a variety of programmable on-chip terminations options, including:

- Dynamically switchable Single Ended Termination for SSTL15 inputs with programmable resistor values of 40, 50, or 60 ohms. This is particularly useful for low power JEDEC compliant DDR3 memory controller implementations. External termination to Vtt should be used for DDR2 memory controller implementation.
- Common mode termination of 80, 100, 120 ohms for differential inputs

Figure 2-39. On-Chip Termination



See Table 2-12 for termination options for input modes.

Table 2-12. On-Chip Termination Options for Input Modes

IO_TYPE	TERMINATE to VTT ^{1,2}	DIFFERENTIAL TERMINATION RESISTOR ¹
LVDS25	␣	80, 100, 120
BLVDS25	␣	80, 100, 120
MLVDS	␣	80, 100, 120
HSTL18_I	40, 50, 60	␣
HSTL18_II	40, 50, 60	␣
HSTL18D_I	40, 50, 60	␣
HSTL18D_II	40, 50, 60	␣
HSTL15_I	40, 50, 60	␣
HSTL15D_I	40, 50, 60	␣
SSTL25_I	40, 50, 60	␣
SSTL25_II	40, 50, 60	␣
SSTL25D_I	40, 50, 60	␣
SSTL25D_II	40, 50, 60	␣
SSTL18_I	40, 50, 60	␣
SSTL18_II	40, 50, 60	␣
SSTL18D_I	40, 50, 60	␣
SSTL18D_II	40, 50, 60	␣
SSTL15	40, 50, 60	␣
SSTL15D	40, 50, 60	␣

1. TERMINATE to VTT and DIFFERENTIAL TERMINATION RESISTOR when turn on can only have one setting per bank. Only left and right banks have this feature.
Use of TERMINATE to VTT and DIFFERENTIAL TERMINATION RESISTOR are mutually exclusive in an I/O bank.
On-chip termination tolerance +/- 20%

2. External termination to VTT should be used when implementing DDR2 memory controller.

Please see TN1177, [LatticeECP3 sysIO Usage Guide](#) for on-chip termination usage and value ranges.

Equalization Filter

Equalization filtering is available for single-ended inputs on both true and complementary I/Os, and for differential inputs on the true I/Os on the left, right, and top sides. Equalization is required to compensate for the difficulty of sampling alternating logic transitions with a relatively slow slew rate. It is considered the most useful for the Input DDRX2 modes, used in DDR3 memory, LVDS, or TRLVDS signaling. Equalization filter acts as a tunable filter with settings to determine the level of correction. In the LatticeECP3 devices, there are four settings available: 0 (none), 1, 2 and 3. The default setting is 0. The equalization logic resides in the sysIO buffers, the two bits of setting is set uniquely in each input IOLOGIC block. Therefore, each sysIO can have a unique equalization setting within a DQS-12 group.

Hot Socketing

LatticeECP3 devices have been carefully designed to ensure predictable behavior during power-up and power-down. During power-up and power-down sequences, the I/Os remain in tri-state until the power supply voltage is high enough to ensure reliable operation. In addition, leakage into I/O pins is controlled within specified limits. Please refer to the Hot Socketing Specifications in the DC and Switching Characteristics in this data sheet.

SERDES and PCS (Physical Coding Sublayer)

LatticeECP3 devices feature up to 16 channels of embedded SERDES/PCS arranged in quads at the bottom of the devices supporting up to 3.2Gbps data rate. Figure 2-40 shows the position of the quad blocks for the LatticeECP3-150 devices. Table 2-14 shows the location of available SERDES Quads for all devices.

The LatticeECP3 SERDES/PCS supports a range of popular serial protocols, including:

- PCI Express 1.1
- Ethernet (XAUI, GbE - 1000 Base CS/SX/LX and SGMII)
- Serial RapidIO
- SMPTE SDI (3G, HD, SD)
- CPRI
- SONET/SDH (STS-3, STS-12, STS-48)

Each quad contains four dedicated SERDES for high speed, full duplex serial data transfer. Each quad also has a PCS block that interfaces to the SERDES channels and contains protocol specific digital logic to support the standards listed above. The PCS block also contains interface logic to the FPGA fabric. All PCS logic for dedicated protocol support can also be bypassed to allow raw 8-bit or 10-bit interfaces to the FPGA fabric.

Even though the SERDES/PCS blocks are arranged in quads, multiple baud rates can be supported within a quad with the use of dedicated, per channel $\div 1$, $\div 2$ and $\div 11$ rate dividers. Additionally, multiple quads can be arranged together to form larger data pipes.

For information on how to use the SERDES/PCS blocks to support specific protocols, as well on how to combine multiple protocols and baud rates within a device, please refer to TN1176, [LatticeECP3 SERDES/PCS Usage Guide](#).

Figure 2-40. SERDES/PCS Quads (LatticeECP3-150)



Table 2-13. LatticeECP3 SERDES Standard Support

Standard	Data Rate (Mbps)	Number of General/Link Width	Encoding Style
PCI Express 1.1	2500	x1, x2, x4	8b10b
Gigabit Ethernet	1250, 2500	x1	8b10b
SGMII	1250	x1	8b10b
XAUI	3125	x4	8b10b
Serial RapidIO Type I, Serial RapidIO Type II, Serial RapidIO Type III	1250, 2500, 3125	x1, x4	8b10b
CPRI-1, CPRI-2, CPRI-3, CPRI-4	614.4, 1228.8, 2457.6, 3072.0	x1	8b10b
SD-SDI (259M, 344M)	143 ¹ , 177 ¹ , 270, 360, 540	x1	NRZI/Scrambled
HD-SDI (292M)	1483.5, 1485	x1	NRZI/Scrambled
3G-SDI (424M)	2967, 2970	x1	NRZI/Scrambled
SONET-STS-3 ²	155.52	x1	N/A
SONET-STS-12 ²	622.08	x1	N/A
SONET-STS-48 ²	2488	x1	N/A

1. For slower rates, the SERDES are bypassed and CML signals are directly connected to the FPGA routing.

2. The SONET protocol is supported in 8-bit SERDES mode. See TN1176 [Lattice ECP3 SERDES/PCS Usage Guide](#) for more information.

Table 2-14. Available SERDES Quads per LatticeECP3 Devices

Package	ECP3-17	ECP3-35	ECP3-70	ECP3-95	ECP3-150
256 ftBGA	1	1	—	—	—
484 ftBGA	1	1	1	1	—
672 ftBGA	—	1	2	2	2
1156 ftBGA	—	—	3	3	4

SERDES Block

A SERDES receiver channel may receive the serial differential data stream, equalize the signal, perform Clock and Data Recovery (CDR) and de-serialize the data stream before passing the 8- or 10-bit data to the PCS logic. The SERDES transmitter channel may receive the parallel 8- or 10-bit data, serialize the data and transmit the serial bit stream through the differential drivers. Figure 2-41 shows a single-channel SERDES/PCS block. Each SERDES channel provides a recovered clock and a SERDES transmit clock to the PCS block and to the FPGA core logic.

Each transmit channel, receiver channel, and SERDES PLL shares the same power supply (VCCA). The output and input buffers of each channel have their own independent power supplies (VCCOB and VCCIB).

Figure 2-41. Simplified Channel Block Diagram for SERDES/PCS Block

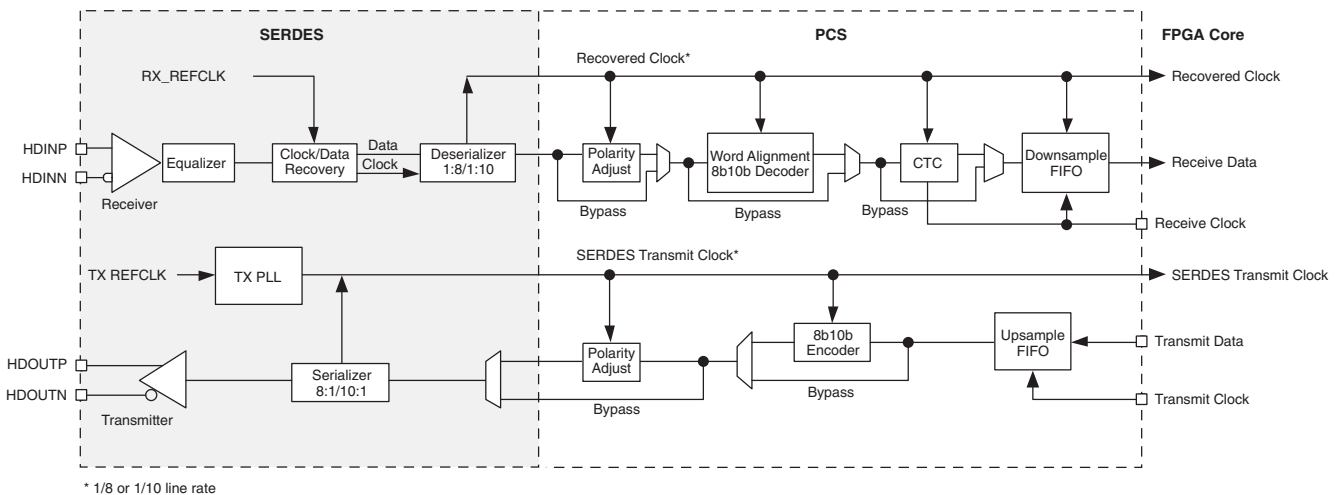

PCS

As shown in Figure 2-41, the PCS receives the parallel digital data from the deserializer and selects the polarity, performs word alignment, decodes (8b/10b), provides Clock Tolerance Compensation and transfers the clock domain from the recovered clock to the FPGA clock via the Down Sample FIFO.

For the transmit channel, the PCS block receives the parallel data from the FPGA core, encodes it with 8b/10b, selects the polarity and passes the 8/10 bit data to the transmit SERDES channel.

The PCS also provides bypass modes that allow a direct 8-bit or 10-bit interface from the SERDES to the FPGA logic. The PCS interface to the FPGA can also be programmed to run at 1/2 speed for a 16-bit or 20-bit interface to the FPGA logic.

SCI (SERDES Client Interface) Bus

The SERDES Client Interface (SCI) is an IP interface that allows the SERDES/PCS Quad block to be controlled by registers rather than the configuration memory cells. It is a simple register configuration interface that allows SERDES/PCS configuration without power cycling the device.

The ispLEVER design tools from Lattice support all modes of the PCS. Most modes are dedicated to applications associated with a specific industry standard data protocol. Other more general purpose modes allow users to define their own operation. With ispLEVER, the user can define the mode for each quad in a design.

Popular standards such as 10Gb Ethernet, x4 PCI Express and 4x Serial RapidIO can be implemented using IP (available through Lattice), a single quad (Four SERDES channels and PCS) and some additional logic from the core.

The LatticeECP3 family also supports a wide range of primary and secondary protocols. Within the same quad, the LatticeECP3 family can support mixed protocols with semi-independent clocking as long as the required clock frequencies are integer x1, x2, or x11 multiples of each other. Table 2-15 lists the allowable combination of primary and secondary protocol combinations.

Flexible Quad SERDES Architecture

The LatticeECP3 family SERDES architecture is a quad-based architecture. For most SERDES settings and standards, the whole quad (consisting of four SERDES) is treated as a unit. This helps in silicon area savings, better utilization and overall lower cost.

However, for some specific standards, the LatticeECP3 quad architecture provides flexibility; more than one standard can be supported within the same quad.

Table 2-15 shows the standards can be mixed and matched within the same quad. In general, the SERDES standards whose nominal data rates are either the same or a defined subset of each other, can be supported within the same quad. In Table 2-15, the Primary Protocol column refers to the standard that determines the reference clock and PLL settings. The Secondary Protocol column shows the other standard that can be supported within the same quad.

Furthermore, Table 2-15 also implies that more than two standards in the same quad can be supported, as long as they conform to the data rate and reference clock requirements. For example, a quad may contain PCI Express 1.1, SGMII, Serial RapidIO Type I and Serial RapidIO Type II, all in the same quad.

Table 2-15. LatticeECP3 Primary and Secondary Protocol Support

Primary Protocol	Secondary Protocol
PCI Express 1.1	SGMII
PCI Express 1.1	Gigabit Ethernet
PCI Express 1.1	Serial RapidIO Type I
PCI Express 1.1	Serial RapidIO Type II
Serial RapidIO Type I	SGMII
Serial RapidIO Type I	Gigabit Ethernet
Serial RapidIO Type II	SGMII
Serial RapidIO Type II	Gigabit Ethernet
Serial RapidIO Type II	Serial RapidIO Type I
CPRI-3	CPRI-2 and CPRI-1
3G-SDI	HD-SDI and SD-SDI

For further information on SERDES, please see TN1176, [LatticeECP3 SERDES/PCS Usage Guide](#).

IEEE 1149.1-Compliant Boundary Scan Testability

All LatticeECP3 devices have boundary scan cells that are accessed through an IEEE 1149.1 compliant Test Access Port (TAP). This allows functional testing of the circuit board on which the device is mounted through a serial scan path that can access all critical logic nodes. Internal registers are linked internally, allowing test data to be shifted in and loaded directly onto test nodes, or test data to be captured and shifted out for verification. The test

access port consists of dedicated I/Os: TDI, TDO, TCK and TMS. The test access port has its own supply voltage V_{CCJ} and can operate with LVCMOS3.3, 2.5, 1.8, 1.5 and 1.2 standards.

For more information, please see TN1169, [LatticeECP3 sysCONFIG Usage Guide](#).

Device Configuration

All LatticeECP3 devices contain two ports that can be used for device configuration. The Test Access Port (TAP), which supports bit-wide configuration, and the sysCONFIG port, support dual-byte, byte and serial configuration. The TAP supports both the IEEE Standard 1149.1 Boundary Scan specification and the IEEE Standard 1532 In-System Configuration specification. The sysCONFIG port includes seven I/Os used as dedicated pins with the remaining pins used as dual-use pins. See TN1169, [LatticeECP3 sysCONFIG Usage Guide](#) for more information about using the dual-use pins as general purpose I/Os.

There are various ways to configure a LatticeECP3 device:

1. JTAG
2. Standard Serial Peripheral Interface (SPI and SPIm modes) - interface to boot PROM memory
3. System microprocessor to drive a x8 CPU port (PCM mode)
4. System microprocessor to drive a serial slave SPI port (SSPI mode)
5. Generic byte wide flash with a MachXO™ device, providing control and addressing

On power-up, the FPGA SRAM is ready to be configured using the selected sysCONFIG port. Once a configuration port is selected, it will remain active throughout that configuration cycle. The IEEE 1149.1 port can be activated any time after power-up by sending the appropriate command through the TAP port.

LatticeECP3 devices also support the Slave SPI Interface. In this mode, the FPGA behaves like a SPI Flash device (slave mode) with the SPI port of the FPGA to perform read-write operations.

Enhanced Configuration Options

LatticeECP3 devices have enhanced configuration features such as: decryption support, TransFR™ I/O and dual-boot image support.

1. TransFR (Transparent Field Reconfiguration)

TransFR I/O (TFR) is a unique Lattice technology that allows users to update their logic in the field without interrupting system operation using a single ispVM command. TransFR I/O allows I/O states to be frozen during device configuration. This allows the device to be field updated with a minimum of system disruption and downtime. See TN1087, [Minimizing System Interruption During Configuration Using TransFR Technology](#) for details.

2. Dual-Boot Image Support

Dual-boot images are supported for applications requiring reliable remote updates of configuration data for the system FPGA. After the system is running with a basic configuration, a new boot image can be downloaded remotely and stored in a separate location in the configuration storage device. Any time after the update the LatticeECP3 can be re-booted from this new configuration file. If there is a problem, such as corrupt data during download or incorrect version number with this new boot image, the LatticeECP3 device can revert back to the original backup golden configuration and try again. This all can be done without power cycling the system. For more information, please see TN1169, [LatticeECP3 sysCONFIG Usage Guide](#).

Soft Error Detect (SED) Support

LatticeECP3 devices have dedicated logic to perform Cycle Redundancy Code (CRC) checks. During configuration, the configuration data bitstream can be checked with the CRC logic block. In addition, the LatticeECP3 device

can also be programmed to utilize a Soft Error Detect (SED) mode that checks for soft errors in configuration SRAM. The SED operation can be run in the background during user mode. If a soft error occurs, during user mode (normal operation) the device can be programmed to generate an error signal.

For further information on SED support, please see TN1184, [LatticeECP3 Soft Error Detection \(SED\) Usage Guide](#).

External Resistor

LatticeECP3 devices require a single external, 10K ohm $\pm 1\%$ value between the XRES pin and ground. Device configuration will not be completed if this resistor is missing. There is no boundary scan register on the external resistor pad.

On-Chip Oscillator

Every LatticeECP3 device has an internal CMOS oscillator which is used to derive a Master Clock (MCLK) for configuration. The oscillator and the MCLK run continuously and are available to user logic after configuration is completed. The software default value of the MCLK is nominally 2.5MHz. Table 2-16 lists all the available MCLK frequencies. When a different Master Clock is selected during the design process, the following sequence takes place:

1. Device powers up with a nominal Master Clock frequency of 3.1MHz.
2. During configuration, users select a different master clock frequency.
3. The Master Clock frequency changes to the selected frequency once the clock configuration bits are received.
4. If the user does not select a master clock frequency, then the configuration bitstream defaults to the MCLK frequency of 2.5MHz.

This internal CMOS oscillator is available to the user by routing it as an input clock to the clock tree. For further information on the use of this oscillator for configuration or user mode, please see TN1169, [LatticeECP3 sysCONFIG Usage Guide](#).

Table 2-16. Selectable Master Clock (MCLK) Frequencies During Configuration (Nominal)

MCLK (MHz)	MCLK (MHz)	MCLK (MHz)
2.5 ¹	10	41
3.1	13	45
4.3	15	51
5.4	20	55
6.9	26	60
8.1	30	130
9.2	34	—

1. Software default MCLK frequency. Hardware default is 3.1MHz.

Density Shifting

The LatticeECP3 family is designed to ensure that different density devices in the same family and in the same package have the same pinout. Furthermore, the architecture ensures a high success rate when performing design migration from lower density devices to higher density devices. In many cases, it is also possible to shift a lower utilization design targeted for a high-density device to a lower density device. However, the exact details of the final resource utilization will impact the likelihood of success in each case. An example is that some user I/Os may become No Connects in smaller devices in the same package.

Absolute Maximum Ratings^{1, 2, 3}

Supply Voltage V_{CC}	-0.5 to 1.32V
Supply Voltage V_{CCAUX}	-0.5 to 3.75V
Supply Voltage V_{CCJ}	-0.5 to 3.75V
Output Supply Voltage V_{CCIO}	-0.5 to 3.75V
Input or I/O Tristate Voltage Applied ⁴	-0.5 to 3.75V
Storage Temperature (Ambient)	-65 to 150°C
Junction Temperature (T_j)	+125°C

1. Stress above those listed under the "Absolute Maximum Ratings" may cause permanent damage to the device. Functional operation of the device at these or any other conditions above those indicated in the operational sections of this specification is not implied.
2. Compliance with the Lattice [Thermal Management](#) document is required.
3. All voltages referenced to GND.
4. Overshoot and undershoot of -2V to ($V_{IHMAX} + 2$) volts is permitted for a duration of <20ns.

Recommended Operating Conditions¹

Symbol	Parameter	Min.	Max.	Units
V_{CC}^2	Core Supply Voltage	1.14	1.26	V
$V_{CCAUX}^{2,4}$	Auxiliary Supply Voltage, Terminating Resistor Switching Power Supply (SERDES)	3.135	3.465	V
V_{CCPLL}	PLL Supply Voltage	3.135	3.465	V
$V_{CCIO}^{2,3}$	I/O Driver Supply Voltage	1.14	3.465	V
V_{CCJ}^2	Supply Voltage for IEEE 1149.1 Test Access Port	1.14	3.465	V
V_{REF1} and V_{REF2}	Input Reference Voltage	0.5	1.7	V
V_{TT}^5	Termination Voltage	0.5	1.3125	V
t_{JCOM}	Junction Temperature, Commercial Operation	0	85	°C
t_{JIND}	Junction Temperature, Industrial Operation	-40	100	°C
SERDES External Power Supply⁶				
V_{CCIB}	Input Buffer Power Supply (1.2V)	1.14	1.26	V
	Input Buffer Power Supply (1.5V)	1.425	1.575	V
V_{CCOB}	Output Buffer Power Supply (1.2V)	1.14	1.26	V
	Output Buffer Power Supply (1.5V)	1.425	1.575	V
V_{CCA}	Transmit, Receive, PLL and Reference Clock Buffer Power Supply	1.14	1.26	V

1. For correct operation, all supplies except V_{REF} and V_{TT} must be held in their valid operation range. This is true independent of feature usage.
2. If V_{CCIO} or V_{CCJ} is set to 1.2V, they must be connected to the same power supply as V_{CC} . If V_{CCIO} or V_{CCJ} is set to 3.3V, they must be connected to the same power supply as V_{CCAUX} .
3. See recommended voltages by I/O standard in subsequent table.
4. V_{CCAUX} ramp rate must not exceed 30mV/ μ s during power-up when transitioning between 0V and 3.3V.
5. If not used, V_{TT} should be left floating.
6. See TN1176, [LatticeECP3 SERDES/PCS Usage Guide](#) for information on board considerations for SERDES power supplies.

Hot Socketing Specifications^{1, 3, 4}

Symbol	Parameter	Condition	Min.	Typ.	Max.	Units
IDK_HS ²	Input or I/O Leakage Current	$0 \leq V_{IN} \leq V_{IH}$ (Max.)	—	—	+/-1	mA
IDK ⁵	Input or I/O Leakage Current	$0 \leq V_{IN} < V_{CCIO}$	—	—	+/-1	mA
		$V_{CCIO} \leq V_{IN} \leq V_{CCIO} + 0.5V$	—	18	—	mA

1. V_{CC} , V_{CCAUX} and V_{CCIO} should rise/fall monotonically.
2. Applicable to general purpose I/O pins in top I/O banks only.
3. I_{DK} is additive to I_{PU} , I_{PW} or I_{BH} .
4. LVCMOS and LVTTTL only.
5. Applicable to general purpose I/O pins in left and right I/O banks only.

Hot Socketing Requirements^{1, 2}

Description	Min.	Typ.	Max.	Units
Input current per SERDES I/O pin when device is powered down and inputs driven.	—	—	8	mA

1. Assumes the device is powered down, all supplies grounded, both P and N inputs driven by CML driver with maximum allowed V_{CCOB} (1.575V), 8b10b data, internal AC coupling.
2. Each P and N input must have less than the specified maximum input current. For a 16-channel device, the total input current would be $8mA * 16 \text{ channels} * 2 \text{ input pins per channel} = 256mA$

ESD Performance

Pin Group	ESD Stress	Min.	Units
All pins	HBM	1000	V
All pins except high-speed serial and XRES ¹	CDM	500	V
High-speed serial inputs	CDM	400	V

1. The XRES pin on the TW device passes CDM testing at 250V.

DC Electrical Characteristics

Over Recommended Operating Conditions

Symbol	Parameter	Condition	Min.	Typ.	Max.	Units
$I_{IL}, I_{IH}^{1,4}$	Input or I/O Low Leakage	$0 \leq V_{IN} \leq (V_{CCIO} - 0.2V)$	—	—	10	μA
$I_{IH}^{1,3}$	Input or I/O High Leakage	$(V_{CCIO} - 0.2V) < V_{IN} \leq 3.6V$	—	—	150	μA
I_{PU}	I/O Active Pull-up Current	$0 \leq V_{IN} \leq 0.7 V_{CCIO}$	-30	—	-210	μA
I_{PD}	I/O Active Pull-down Current	$V_{IL} (MAX) \leq V_{IN} \leq V_{CCIO}$	30	—	210	μA
I_{BHLS}	Bus Hold Low Sustaining Current	$V_{IN} = V_{IL} (MAX)$	30	—	—	μA
I_{BHHS}	Bus Hold High Sustaining Current	$V_{IN} = 0.7 V_{CCIO}$	-30	—	—	μA
I_{BHLO}	Bus Hold Low Overdrive Current	$0 \leq V_{IN} \leq V_{CCIO}$	—	—	210	μA
I_{BHHO}	Bus Hold High Overdrive Current	$0 \leq V_{IN} \leq V_{CCIO}$	—	—	-210	μA
V_{BHT}	Bus Hold Trip Points	$0 \leq V_{IN} \leq V_{IH} (MAX)$	$V_{IL} (MAX)$	—	$V_{IH} (MIN)$	V
C1	I/O Capacitance ²	$V_{CCIO} = 3.3V, 2.5V, 1.8V, 1.5V, 1.2V,$ $V_{CC} = 1.2V, V_{IO} = 0 \text{ to } V_{IH} (MAX)$	—	8	—	pf
C2	Dedicated Input Capacitance ²	$V_{CCIO} = 3.3V, 2.5V, 1.8V, 1.5V, 1.2V,$ $V_{CC} = 1.2V, V_{IO} = 0 \text{ to } V_{IH} (MAX)$	—	6	—	pf

1. Input or I/O leakage current is measured with the pin configured as an input or as an I/O with the output driver tri-stated. It is not measured with the output driver active. Bus maintenance circuits are disabled.

2. T_A 25°C, $f = 1.0MHz$.

3. Applicable to general purpose I/Os in top and bottom banks.

4. When used as V_{REF} maximum leakage = 25 μA .

LatticeECP3 Supply Current (Standby)^{1, 2, 3, 4, 5, 6}

Over Recommended Operating Conditions

Symbol	Parameter	Device	Typical	Units
I _{CC}	Core Power Supply Current	ECP-17EA	89.30	mA
		ECP3-35EA	89.30	mA
		ECP3-70E	226.30	mA
		ECP3-70EA	230.60	mA
		ECP3-95E	226.30	mA
		ECP3-95EA	230.60	mA
		ECP3-150EA	370.80	mA
I _{CCAUX}	Auxiliary Power Supply Current	ECP-17EA	28.20	mA
		ECP3-35EA	28.20	mA
		ECP3-70E	30.60	mA
		ECP3-70EA	30.60	mA
		ECP3-95E	30.60	mA
		ECP3-95EA	30.60	mA
		ECP3-150EA	45.70	mA
I _{CCPLL}	PLL Power Supply Current (Per PLL)	ECP-17EA	0.05	mA
		ECP3-35EA	0.03	mA
		ECP3-70E	0.02	mA
		ECP3-70EA	0.02	mA
		ECP3-95E	0.02	mA
		ECP3-95EA	0.02	mA
		ECP3-150EA	0.02	mA
I _{CCIO}	Bank Power Supply Current (Per Bank)	ECP-17EA	1.38	mA
		ECP3-35EA	1.38	mA
		ECP3-70E	1.43	mA
		ECP3-70EA	1.43	mA
		ECP3-95E	1.43	mA
		ECP3-95EA	1.43	mA
		ECP3-150EA	1.46	mA
I _{CCJ}	JTAG Power Supply Current	All Devices	2.50	mA
I _{CCA}	Transmit, Receive, PLL and Reference Clock Buffer Power Supply	ECP-17EA	5.90	mA
		ECP3-35EA	5.90	mA
		ECP3-70E	17.80	mA
		ECP3-70EA	17.80	mA
		ECP3-95E	17.80	mA
		ECP3-95EA	17.80	mA
		ECP3-150EA	23.80	mA

1. For further information on supply current, please see the list of technical documentation at the end of this data sheet.
2. Assumes all outputs are tristated, all inputs are configured as LVCMOS and held at the V_{CCIO} or GND.
3. Frequency 0 MHz.
4. Pattern represents a “blank” configuration data file.
5. T_J = 85°C, power supplies at nominal voltage.
6. To determine the LatticeECP3 peak start-up current data, use the Power Calculator tool in ispLEVER.

SERDES Power Supply Requirements^{1, 2, 3}**Over Recommended Operating Conditions**

Symbol	Description	Typ.	Max.	Units
Standby (Power Down)				
I_{CCA-SB}	V_{CCA} current (per channel)	3	5	mA
$I_{CCIB-SB}$	Input buffer current (per channel)	—	—	mA
$I_{CCOB-SB}$	Output buffer current (per channel)	—	—	mA
Operating (Data Rate = 3.2 Gbps)				
I_{CCA-OP}	V_{CCA} current (per channel)	68	77	mA
$I_{CCIB-OP}$	Input buffer current (per channel)	5	7	mA
$I_{CCOB-OP}$	Output buffer current (per channel)	19	25	mA
Operating (Data Rate = 2.5 Gbps)				
I_{CCA-OP}	V_{CCA} current (per channel)	66	76	mA
$I_{CCIB-OP}$	Input buffer current (per channel)	4	5	mA
$I_{CCOB-OP}$	Output buffer current (per channel)	15	18	mA
Operating (Data Rate = 1.25 Gbps)				
I_{CCA-OP}	V_{CCA} current (per channel)	62	72	mA
$I_{CCIB-OP}$	Input buffer current (per channel)	4	5	mA
$I_{CCOB-OP}$	Output buffer current (per channel)	15	18	mA
Operating (Data Rate = 250 Mbps)				
I_{CCA-OP}	V_{CCA} current (per channel)	55	65	mA
$I_{CCIB-OP}$	Input buffer current (per channel)	4	5	mA
$I_{CCOB-OP}$	Output buffer current (per channel)	14	17	mA

1. Equalization enabled, pre-emphasis disabled.

2. One quarter of the total quad power (includes contribution from common circuits, all channels in the quad operating, pre-emphasis disabled, equalization enabled).

3. Pre-emphasis adds 20mA to I_{CCA-OP} data.

sysI/O Recommended Operating Conditions

Standard	V _{CCIO}			V _{REF} (V)		
	Min.	Typ.	Max.	Min.	Typ.	Max.
LVC MOS33 ²	3.135	3.3	3.465	—	—	—
LVC MOS25 ²	2.375	2.5	2.625	—	—	—
LVC MOS18	1.71	1.8	1.89	—	—	—
LVC MOS15	1.425	1.5	1.575	—	—	—
LVC MOS12 ²	1.14	1.2	1.26	—	—	—
LV TTL33 ²	3.135	3.3	3.465	—	—	—
PCI33	3.135	3.3	3.465	—	—	—
SSTL15 ³	1.43	1.5	1.57	0.68	0.75	0.9
SSTL18_I, II ²	1.71	1.8	1.89	0.833	0.9	0.969
SSTL25_I, II ²	2.375	2.5	2.625	1.15	1.25	1.35
SSTL33_I, II ²	3.135	3.3	3.465	1.3	1.5	1.7
HSTL15_I ²	1.425	1.5	1.575	0.68	0.75	0.9
HSTL18_I, II ²	1.71	1.8	1.89	0.816	0.9	1.08
LVDS25 ²	2.375	2.5	2.625	—	—	—
MLVDS25 ¹	2.375	2.5	2.625	—	—	—
LVPECL33 ^{1,2}	3.135	3.3	3.465	—	—	—
Mini LVDS	—	—	—	—	—	—
BLVDS25 ^{1,2}	2.375	2.5	2.625	—	—	—
RSDS25 ^{1,2}	2.375	2.5	2.625	—	—	—
RSDS25E ^{1,2}	2.375	2.5	2.625	—	—	—
TRLVDS	3.14	3.3	3.47	—	—	—
PPLVDS	3.14/2.25	3.3/2.5	3.47/2.75	—	—	—
SSTL15D	1.43	1.5	1.57	—	—	—
SSTL18D_I ² , II ²	1.71	1.8	1.89	—	—	—
SSTL25D_I ² , II ²	2.375	2.5	2.625	—	—	—
SSTL33D_I ² , II ²	3.135	3.3	3.465	—	—	—
HSTL15D_I ²	1.425	1.5	1.575	—	—	—
HSTL18D_I ² , II ²	1.71	1.8	1.89	—	—	—

1. Inputs on chip. Outputs are implemented with the addition of external resistors.

2. For input voltage compatibility, refer to the "Mixed Voltage Support" section of TN1177, [LatticeECP3 sysI/O Usage Guide](#).

sysI/O Single-Ended DC Electrical Characteristics

Input/Output Standard	V_{IL}		V_{IH}		V_{OL} Max. (V)	V_{OH} Min. (V)	I_{OL}^1 (mA)	I_{OH}^1 (mA)
	Min. (V)	Max. (V)	Min. (V)	Max. (V)				
LVCMOS33	-0.3	0.8	2.0	3.6	0.4	$V_{CCIO} - 0.4$	20, 16, 12, 8, 4	-20, -16, -12, -8, -4
					0.2	$V_{CCIO} - 0.2$	0.1	-0.1
LVCMOS25	-0.3	0.7	1.7	3.6	0.4	$V_{CCIO} - 0.4$	20, 16, 12, 8, 4	-20, -16, -12, -8, -4
					0.2	$V_{CCIO} - 0.2$	0.1	-0.1
LVCMOS18	-0.3	$0.35 V_{CCIO}$	$0.65 V_{CCIO}$	3.6	0.4	$V_{CCIO} - 0.4$	16, 12, 8, 4	-16, -12, -8, -4
					0.2	$V_{CCIO} - 0.2$	0.1	-0.1
LVCMOS15	-0.3	$0.35 V_{CCIO}$	$0.65 V_{CCIO}$	3.6	0.4	$V_{CCIO} - 0.4$	8, 4	-8, -4
					0.2	$V_{CCIO} - 0.2$	0.1	-0.1
LVCMOS12	-0.3	$0.35 V_{CC}$	$0.65 V_{CC}$	3.6	0.4	$V_{CCIO} - 0.4$	6, 2	-6, -2
					0.2	$V_{CCIO} - 0.2$	0.1	-0.1
LVTTTL33	-0.3	0.8	2.0	3.6	0.4	$V_{CCIO} - 0.4$	20, 16, 12, 8, 4	-20, -16, -12, -8, -4
					0.2	$V_{CCIO} - 0.2$	0.1	-0.1
PCI33	-0.3	$0.3 V_{CCIO}$	$0.5 V_{CCIO}$	3.6	$0.1 V_{CCIO}$	$0.9 V_{CCIO}$	1.5	-0.5
SSTL18_I	-0.3	$V_{REF} - 0.125$	$V_{REF} + 0.125$	3.6	0.4	$V_{CCIO} - 0.4$	6.7	-6.7
SSTL18_II (DDR2 Memory)	-0.3	$V_{REF} - 0.125$	$V_{REF} + 0.125$	3.6	0.28	$V_{CCIO} - 0.28$	8	-8
							11	-11
SSTL2_I	-0.3	$V_{REF} - 0.18$	$V_{REF} + 0.18$	3.6	0.54	$V_{CCIO} - 0.62$	7.6	-7.6
							12	-12
SSTL2_II (DDR2 Memory)	-0.3	$V_{REF} - 0.18$	$V_{REF} + 0.18$	3.6	0.35	$V_{CCIO} - 0.43$	15.2	-15.2
							20	-20
SSTL3_I	-0.3	$V_{REF} - 0.2$	$V_{REF} + 0.2$	3.6	0.7	$V_{CCIO} - 1.1$	8	-8
SSTL3_II	-0.3	$V_{REF} - 0.2$	$V_{REF} + 0.2$	3.6	0.5	$V_{CCIO} - 0.9$	16	-16
SSTL15 (DDR3 Memory)	-0.3	$V_{REF} - 0.1$	$V_{REF} + 0.1$	3.6	0.3	$V_{CCIO} - 0.3$	7.5	-7.5
						$V_{CCIO} * 0.8$	9	-9
HSTL15_I	-0.3	$V_{REF} - 0.1$	$V_{REF} + 0.1$	3.6	0.4	$V_{CCIO} - 0.4$	4	-4
							8	-8
HSTL18_I	-0.3	$V_{REF} - 0.1$	$V_{REF} + 0.1$	3.6	0.4	$V_{CCIO} - 0.4$	8	-8
							12	-12
HSTL18_II	-0.3	$V_{REF} - 0.1$	$V_{REF} + 0.1$	3.6	0.4	$V_{CCIO} - 0.4$	16	-16

1. The average DC current drawn by I/Os between GND connections, or between the last GND in an I/O bank and the end of an I/O bank, as shown in the logic signal connections table shall not exceed $n * 8\text{mA}$, where n is the number of I/Os between bank GND connections or between the last GND in a bank and the end of a bank.

sysI/O Differential Electrical Characteristics**LVDS25****Over Recommended Operating Conditions**

Parameter	Description	Test Conditions	Min.	Typ.	Max.	Units
V_{INP} V_{INM}	Input Voltage		0	—	2.4	V
V_{CM}	Input Common Mode Voltage	Half the Sum of the Two Inputs	0.05	—	2.35	V
V_{THD}	Differential Input Threshold	Difference Between the Two Inputs	+/-100	—	—	mV
I_{IN}	Input Current	Power On or Power Off	—	—	+/-10	μ A
V_{OH}	Output High Voltage for V_{OP} or V_{OM}	$R_T = 100$ Ohm	—	1.38	1.60	V
V_{OL}	Output Low Voltage for V_{OP} or V_{OM}	$R_T = 100$ Ohm	0.9V	1.03	—	V
V_{OD}	Output Voltage Differential	$(V_{OP} - V_{OM})$, $R_T = 100$ Ohm	250	350	450	mV
ΔV_{OD}	Change in V_{OD} Between High and Low		—	—	50	mV
V_{OS}	Output Voltage Offset	$(V_{OP} + V_{OM})/2$, $R_T = 100$ Ohm	1.125	1.20	1.375	V
ΔV_{OS}	Change in V_{OS} Between H and L		—	—	50	mV
I_{SAB}	Output Short Circuit Current	$V_{OD} = 0V$ Driver Outputs Shorted to Each Other	—	—	12	mA

Differential HSTL and SSTL

Differential HSTL and SSTL outputs are implemented as a pair of complementary single-ended outputs. All allowable single-ended output classes (class I and class II) are supported in this mode.

LVDS25E

The top and bottom sides of LatticeECP3 devices support LVDS outputs via emulated complementary LVCMOS outputs in conjunction with a parallel resistor across the driver outputs. The scheme shown in Figure 3-1 is one possible solution for point-to-point signals.

Figure 3-1. LVDS25E Output Termination Example

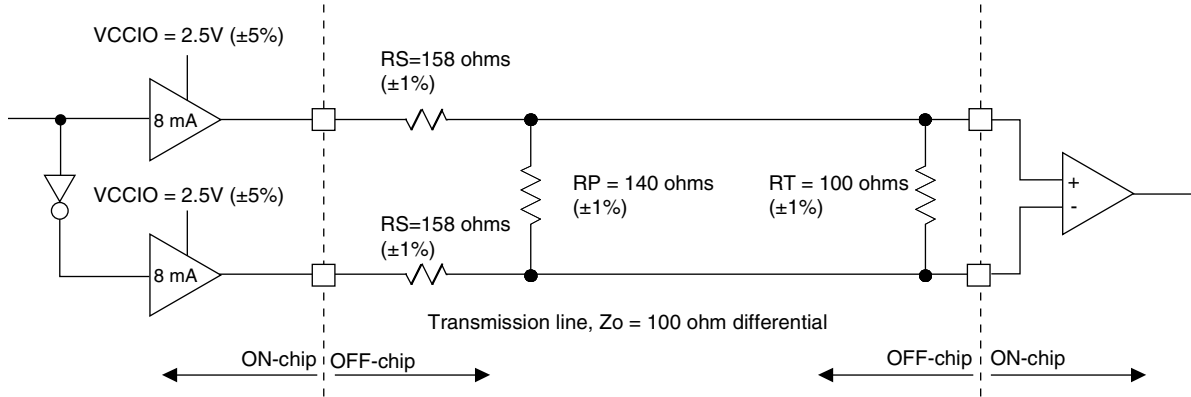

Table 3-1. LVDS25E DC Conditions

Parameter	Description	Typical	Units
V _{CCIO}	Output Driver Supply (+/-5%)	2.50	V
Z _{OUT}	Driver Impedance	20	Ω
R _S	Driver Series Resistor (+/-1%)	158	Ω
R _P	Driver Parallel Resistor (+/-1%)	140	Ω
R _T	Receiver Termination (+/-1%)	100	Ω
V _{OH}	Output High Voltage	1.43	V
V _{OL}	Output Low Voltage	1.07	V
V _{OD}	Output Differential Voltage	0.35	V
V _{CM}	Output Common Mode Voltage	1.25	V
Z _{BACK}	Back Impedance	100.5	Ω
I _{DC}	DC Output Current	6.03	mA

LVCMOS33D

All I/O banks support emulated differential I/O using the LVCMOS33D I/O type. This option, along with the external resistor network, provides the system designer the flexibility to place differential outputs on an I/O bank with 3.3V V_{CCIO}. The default drive current for LVCMOS33D output is 12mA with the option to change the device strength to 4mA, 8mA, 16mA or 20mA. Follow the LVCMOS33 specifications for the DC characteristics of the LVCMOS33D.

BLVDS25

The LatticeECP3 devices support the BLVDS standard. This standard is emulated using complementary LVCMOS outputs in conjunction with a parallel external resistor across the driver outputs. BLVDS is intended for use when multi-drop and bi-directional multi-point differential signaling is required. The scheme shown in Figure 3-2 is one possible solution for bi-directional multi-point differential signals.

Figure 3-2. BLVDS25 Multi-point Output Example



Table 3-2. BLVDS25 DC Conditions¹

Over Recommended Operating Conditions

Parameter	Description	Typical		Units
		Zo = 45Ω	Zo = 90Ω	
V _{CCIO}	Output Driver Supply (+/- 5%)	2.50	2.50	V
Z _{OUT}	Driver Impedance	10.00	10.00	Ω
R _S	Driver Series Resistor (+/- 1%)	90.00	90.00	Ω
R _{TL}	Driver Parallel Resistor (+/- 1%)	45.00	90.00	Ω
R _{TR}	Receiver Termination (+/- 1%)	45.00	90.00	Ω
V _{OH}	Output High Voltage	1.38	1.48	V
V _{OL}	Output Low Voltage	1.12	1.02	V
V _{OD}	Output Differential Voltage	0.25	0.46	V
V _{CM}	Output Common Mode Voltage	1.25	1.25	V
I _{DC}	DC Output Current	11.24	10.20	mA

1. For input buffer, see LVDS table.

LVPECL33

The LatticeECP3 devices support the differential LVPECL standard. This standard is emulated using complementary LVCMOS outputs in conjunction with a parallel resistor across the driver outputs. The LVPECL input standard is supported by the LVDS differential input buffer. The scheme shown in Figure 3-3 is one possible solution for point-to-point signals.

Figure 3-3. Differential LVPECL33



Table 3-3. LVPECL33 DC Conditions¹

Over Recommended Operating Conditions

Parameter	Description	Typical	Units
V_{CCIO}	Output Driver Supply ($\pm 5\%$)	3.30	V
Z_{OUT}	Driver Impedance	10	Ω
R_S	Driver Series Resistor ($\pm 1\%$)	93	Ω
R_P	Driver Parallel Resistor ($\pm 1\%$)	196	Ω
R_T	Receiver Termination ($\pm 1\%$)	100	Ω
V_{OH}	Output High Voltage	2.05	V
V_{OL}	Output Low Voltage	1.25	V
V_{OD}	Output Differential Voltage	0.80	V
V_{CM}	Output Common Mode Voltage	1.65	V
Z_{BACK}	Back Impedance	100.5	Ω
I_{DC}	DC Output Current	12.11	mA

1. For input buffer, see LVDS table.

RSDS25E

The LatticeECP3 devices support differential RSDS and RSDSE standards. This standard is emulated using complementary LVCMOS outputs in conjunction with a parallel resistor across the driver outputs. The RSDS input standard is supported by the LVDS differential input buffer. The scheme shown in Figure 3-4 is one possible solution for RSDS standard implementation. Resistor values in Figure 3-4 are industry standard values for 1% resistors.

Figure 3-4. RSDS25E (Reduced Swing Differential Signaling)

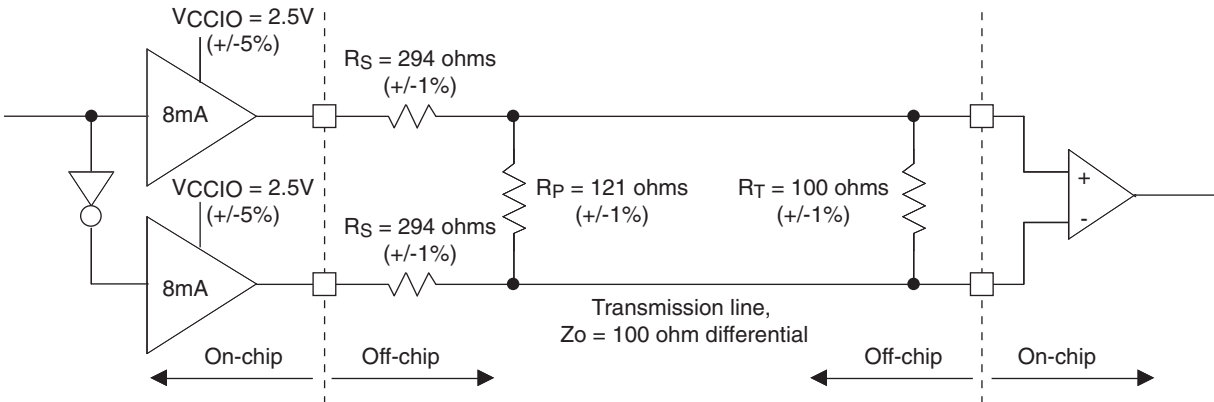

Table 3-4. RSDS25E DC Conditions¹

Over Recommended Operating Conditions

Parameter	Description	Typical	Units
V _{CCIO}	Output Driver Supply (+/-5%)	2.50	V
Z _{OUT}	Driver Impedance	20	Ω
R _S	Driver Series Resistor (+/-1%)	294	Ω
R _P	Driver Parallel Resistor (+/-1%)	121	Ω
R _T	Receiver Termination (+/-1%)	100	Ω
V _{OH}	Output High Voltage	1.35	V
V _{OL}	Output Low Voltage	1.15	V
V _{OD}	Output Differential Voltage	0.20	V
V _{CM}	Output Common Mode Voltage	1.25	V
Z _{BACK}	Back Impedance	101.5	Ω
I _{DC}	DC Output Current	3.66	mA

1. For input buffer, see LVDS table.

MLVDS25

The LatticeECP3 devices support the differential MLVDS standard. This standard is emulated using complementary LVCMOS outputs in conjunction with a parallel resistor across the driver outputs. The MLVDS input standard is supported by the LVDS differential input buffer. The scheme shown in Figure 3-5 is one possible solution for MLVDS standard implementation. Resistor values in Figure 3-5 are industry standard values for 1% resistors.

Figure 3-5. MLVDS25 (Multipoint Low Voltage Differential Signaling)

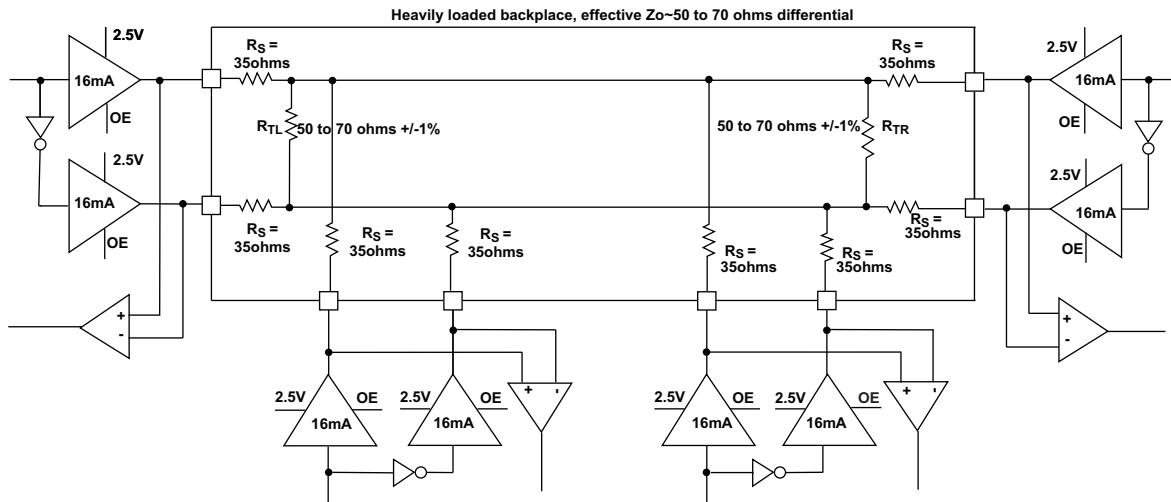

Table 3-5. MLVDS25 DC Conditions¹

Parameter	Description	Typical		Units
		Zo=50Ω	Zo=70Ω	
V _{CCIO}	Output Driver Supply (+/-5%)	2.50	2.50	V
Z _{OUT}	Driver Impedance	10.00	10.00	Ω
R _S	Driver Series Resistor (+/-1%)	35.00	35.00	Ω
R _{TL}	Driver Parallel Resistor (+/-1%)	50.00	70.00	Ω
R _{TR}	Receiver Termination (+/-1%)	50.00	70.00	Ω
V _{OH}	Output High Voltage	1.52	1.60	V
V _{OL}	Output Low Voltage	0.98	0.90	V
V _{OD}	Output Differential Voltage	0.54	0.70	V
V _{CM}	Output Common Mode Voltage	1.25	1.25	V
I _{DC}	DC Output Current	21.74	20.00	mA

1. For input buffer, see LVDS table.

Typical Building Block Function Performance**Pin-to-Pin Performance (LVCMOS25 12mA Drive)^{1,2}**

Function	-8 Timing	Units
Basic Functions		
16-bit Decoder	4.7	ns
32-bit Decoder	4.7	ns
64-bit Decoder	5.7	ns
4:1 MUX	4.1	ns
8:1 MUX	4.3	ns
16:1 MUX	4.7	ns
32:1 MUX	4.8	ns

1. These functions were generated using the ispLEVER design tool. Exact performance may vary with device and tool version. The tool uses internal parameters that have been characterized but are not tested on every device.
2. Commercial timing numbers are shown. Industrial numbers are typically slower and can be extracted from the ispLEVER software.

Register-to-Register Performance^{1,2}

Function	-8 Timing	Units
Basic Functions		
16-bit Decoder	500	MHz
32-bit Decoder	500	MHz
64-bit Decoder	475	MHz
4:1 MUX	500	MHz
8:1 MUX	500	MHz
16:1 MUX	500	MHz
32:1 MUX	445	MHz
8-bit adder	500	MHz
16-bit adder	500	MHz
64-bit adder	305	MHz
16-bit counter	500	MHz
32-bit counter	460	MHz
64-bit counter	320	MHz
64-bit accumulator	315	MHz
Embedded Memory Functions		
512x36 Single Port RAM, EBR Output Registers	340	MHz
1024x18 True-Dual Port RAM (Write Through or Normal, EBR Output Registers)	340	MHz
1024x18 True-Dual Port RAM (Read-Before-Write, EBR Output Registers; EA devices only)	130	MHz
1024x18 True-Dual Port RAM (Write Through or Normal, PLC Output Registers)	245	MHz
Distributed Memory Functions		
16x4 Pseudo-Dual Port RAM (One PFU)	500	MHz
32x4 Pseudo-Dual Port RAM	500	MHz
64x8 Pseudo-Dual Port RAM	380	MHz
DSP Function		
18x18 Multiplier (All Registers)	400	MHz
9x9 Multiplier (All Registers)	400	MHz
36x36 Multiply (All Registers)	245	MHz

Register-to-Register Performance^{1, 2}

Function	-8 Timing	Units
18x18 Multiply/Accumulate (Input & Output Registers)	200	MHz
18x18 Multiply-Add/Sub (All Registers)	400	MHz
DSP IP Functions		
16-Tap Fully-Parallel FIR Filter		MHz
1024-pt, Radix 4, Decimation in Frequency FFT		MHz
8X8 Matrix Multiplication		MHz

1. These timing numbers were generated using ispLEVER tool. Exact performance may vary with device and tool version. The tool uses internal parameters that have been characterized but are not tested on every device.
2. Commercial timing numbers are shown. Industrial numbers are typically slower and can be extracted from the ispLEVER software.

Derating Timing Tables

Logic timing provided in the following sections of this data sheet and the ispLEVER design tools are worst case numbers in the operating range. Actual delays at nominal temperature and voltage for best case process, can be much better than the values given in the tables. The ispLEVER design tool can provide logic timing numbers at a particular temperature and voltage.

LatticeECP3 External Switching Characteristics ^{1,2}

Over Recommended Commercial Operating Conditions

Parameter	Description	Device	-8		-7		-6		Units
			Min.	Max.	Min.	Max.	Min.	Max.	
Clocks									
Primary Clock⁶									
f _{MAX_PRI}	Frequency for Primary Clock Tree	ECP3-150EA	—	500	—	420	—	375	MHz
t _{W_PRI}	Clock Pulse Width for Primary Clock	ECP3-150EA	0.8	—	0.9	—	1.0	—	ns
t _{SKEW_PRI}	Primary Clock Skew Within a Device	ECP3-150EA	—	300	—	330	—	360	ps
t _{SKEW_PRI}	Primary Clock Skew Within a Bank	ECP3-150EA	—	250	—	280	—	300	ps
f _{MAX_PRI}	Frequency for Primary Clock Tree	ECP3-70E/95E	—	500	—	420	—	375	MHz
f _{MAX_PRI}	Frequency for Primary Clock Tree	ECP3-70E/95E	0.8	—	0.9	—	1.0	—	ns
t _{SKEW_PRI}	Primary Clock Skew Within a Device	ECP3-70E/95E	—	300	—	330	—	360	ps
t _{SKEW_PRI}	Primary Clock Skew Within a Bank	ECP3-70E/95E	—	250	—	280	—	300	ps
Edge Clock⁶									
f _{MAX_EDGE}	Frequency for Edge Clock	ECP3-150EA	—	500	—	420	—	375	MHz
t _{W_EDGE}	Clock Pulse Width for Edge Clock	ECP3-150EA	0.9	—	1.0	—	1.2	—	ns
t _{SKEW_EDGE_DQS}	Edge Clock Skew Within an Edge of the Device	ECP3-150EA	—	200	—	210	—	220	ps
f _{MAX_EDGE}	Frequency for Edge Clock	ECP3-70E/95E	—	500	—	420	—	375	MHz
t _{W_EDGE}	Clock Pulse Width for Edge Clock	ECP3-70E/95E	0.9	—	1.0	—	1.2	—	ns
t _{SKEW_EDGE_DQS}	Edge Clock Skew Within an Edge of the Device	ECP3-70E/95E	—	200	—	225	—	250	ps

Parameter	Description	Device	-8		-7		-6		Units
			Min.	Max.	Min.	Max.	Min.	Max.	
Generic SDR									
General I/O Pin Parameters Using Dedicated Clock Input Primary Clock Without PLL²									
t _{CO}	Clock to Output - PIO Output Register	ECP3-150EA	—	4.0	—	4.4	—	4.8	ns
t _{SU}	Clock to Data Setup - PIO Input Register	ECP3-150EA	0.0	—	0.0	—	0.0	—	ns
t _H	Clock to Data Hold - PIO Input Register	ECP3-150EA	1.6	—	1.8	—	2.1	—	ns
t _{SU_DEL}	Clock to Data Setup - PIO Input Register with Data Input Delay	ECP3-150EA	1.2	—	1.3	—	1.5	—	ns
t _{H_DEL}	Clock to Data Hold - PIO Input Register with Input Data Delay	ECP3-150EA	0.1	—	0.1	—	0.1	—	ns
f _{MAX_IO}	Clock Frequency of I/O and PFU Register	ECP3-150EA	—	500	—	420	—	375	MHz
t _{CO}	Clock to Output - PIO Output Register	ECP3-70E/95E	—	3.9	—	4.3	—	4.7	ns
t _{SU}	Clock to Data Setup - PIO Input Register	ECP3-70E/95E	0.0	—	0.0	—	0.0	—	ns
t _H	Clock to Data Hold - PIO Input Register	ECP3-70E/95E	1.5	—	1.8	—	2.0	—	ns
t _{SU_DEL}	Clock to Data Setup - PIO Input Register with Data Input Delay	ECP3-70E/95E	1.3	—	1.5	—	1.8	—	ns
t _{H_DEL}	Clock to Data Hold - PIO Input Register with Input Data Delay	ECP3-70E/95E	0.0	—	0.0	—	0.0	—	ns

LatticeECP3 External Switching Characteristics (Continued)^{1, 2}

Over Recommended Commercial Operating Conditions

Parameter	Description	Device	-8		-7		-6		Units
			Min.	Max.	Min.	Max.	Min.	Max.	
f _{MAX_IO}	Clock Frequency of I/O and PFU Register	ECP3-70E/95E	—	500	—	420	—	375	Mhz
General I/O Pin Parameters Using Dedicated Clock Input Primary Clock with PLL with Clock Injection Removal Setting²									
t _{COPLL}	Clock to Output - PIO Output Register	ECP3-150EA	—	2.5	—	2.7	—	3.1	ns
t _{SUPLL}	Clock to Data Setup - PIO Input Register	ECP3-150EA	0.6	—	0.6	—	0.7	—	ns
t _{HPLL}	Clock to Data Hold - PIO Input Register	ECP3-150EA	0.9	—	1.0	—	1.1	—	ns
t _{SU_DELPLL}	Clock to Data Setup - PIO Input Register with Data Input Delay	ECP3-150EA	1.5	—	1.6	—	1.8	—	ns
t _{H_DELPLL}	Clock to Data Hold - PIO Input Register with Input Data Delay	ECP3-150EA	—	0.1	—	0.1	—	0.1	ns
t _{COPLL}	Clock to Output - PIO Output Register	ECP3-70E/95E	—	2.2	—	2.3	—	2.5	ns
t _{SUPLL}	Clock to Data Setup - PIO Input Register	ECP3-70E/95E	0.6	—	0.7	—	0.8	—	ns
t _{HPLL}	Clock to Data Hold - PIO Input Register	ECP3-70E/95E	0.9	—	1.1	—	1.3	—	ns
t _{SU_DELPLL}	Clock to Data Setup - PIO Input Register with Data Input Delay	ECP3-70E/95E	1.6	—	1.9	—	2.1	—	ns
t _{H_DELPLL}	Clock to Data Hold - PIO Input Register with Input Data Delay	ECP3-70E/95E	0.0	—	0.0	—	0.0	—	ns

Parameter	Description	Device	-8		-7		-6		Units
			Min.	Max.	Min.	Max.	Min.	Max.	
Generic DDR									
Generic DDRX1 Inputs with Clock and Data (>10 Bits Wide) Centered at Pin (GDDRX1_RX.SCLK.Centered) Using PCLK Pin for Clock Input									
Data Left, Right and Top Sides & Clock Left, Right and Top Sides									
t _{SUGDDR}	Data Setup Before CLK	ECP3-150EA	—	—	—	—	—	—	ps
t _{HGDDR}	Data Hold After CLK	ECP3-150EA	—	—	—	—	—	—	ps
f _{MAX_GDDR}	DDRX1 Clock Frequency	ECP3-150EA	—	—	—	—	—	—	MHz
Generic DDRX1 Inputs with Clock in the Center of Data Window, without DLL (GDDRX1_RX.ECLK.Centered)									
t _{SUGDDR}	Data Setup Before CLK	ECP3-70E/95E	515	—	515	—	515	—	ps
t _{HOGDDR}	Data Hold After CLK	ECP3-70E/95E	515	—	515	—	515	—	ps
f _{MAX_GDDR}	DDRX1 Clock Frequency	ECP3-70E/95E	—	250	—	250	—	250	MHz
Generic DDRX1 Inputs with Clock and Data (> 10 Bits Wide) Aligned at Pin (GDDRX1_RX.SCLK.Aligned) using DLL-CLKIN Pin for Clock Input									
Data Left, Right and Top Sides & Clock Left and Right Sides									
t _{DVACLKGGDDR}	Data Setup Before CLK	ECP3-150EA	—	—	—	—	—	—	UI
t _{DVECLKGGDDR}	Data Hold After CLK	ECP3-150EA	—	—	—	—	—	—	UI
f _{MAX_GDDR}	DDRX1 Clock Frequency	ECP3-150EA	—	—	—	—	—	—	MHz
Generic DDRX1 Inputs with Clock and Data Aligned, with DLL (GDDRX1_RX.ECLK.Aligned)									
t _{DVACLKGGDDR}	Data Setup Before CLK	ECP3-70E/95E	—	0.235	—	0.235	—	0.235	UI
t _{DVECLKGGDDR}	Data Hold After CLK	ECP3-70E/95E	0.765	—	0.765	—	0.765	—	UI

LatticeECP3 External Switching Characteristics (Continued)^{1, 2}

Over Recommended Commercial Operating Conditions

Parameter	Description	Device	-8		-7		-6		Units
			Min.	Max.	Min.	Max.	Min.	Max.	
f _{MAX_GDDR}	DDR1 Clock Frequency	ECP3-70E/95E	—	250	—	250	—	250	MHz
Generic DDR1 Inputs with Clock and Data (<10 Bits Wide) Centered at Pin (GDDR1_RX.DQS.Centered) Using DQS Pin for Clock Input									
Left, Right and Top for Data and Clock									
t _{SUGDDR}	Data Valid After CLK	ECP3-150EA	—	—	—	—	—	—	ns
t _{HGDDR}	Data Hold After CLK	ECP3-150EA	—	—	—	—	—	—	ns
f _{MAX_GDDR}	DDR1 Clock Frequency	ECP3-150EA	—	—	—	—	—	—	ns
Generic DDR1 Inputs with Clock and Data (<10 Bits Wide) Aligned at Pin (GDDR1_RX.DQS.Aligned) Using DQS Pin for Clock Input									
Left and Right Sides									
t _{DVACLKDDR}	Data Setup Before CLK (Left and Right Sides)	ECP3-150EA	—	—	—	—	—	—	UI
t _{DVECLKDDR}	Data Hold After CLK (Left and Right Sides)	ECP3-150EA	—	—	—	—	—	—	UI
f _{MAX_GDDR}	DDR1 Clock Frequency (Left and Right Sides)	ECP3-150EA	—	—	—	—	—	—	UI
Top Side									
t _{DVACLKDDR}	Data Setup Before CLK (Top Side)	ECP3-150EA	—	—	—	—	—	—	UI
t _{DVECLKDDR}	Data Hold After CLK (Top Side)	ECP3-150EA	—	—	—	—	—	—	UI
f _{MAX_GDDR}	DDR1 Clock Frequency (Top Side)	ECP3-150EA	—	—	—	—	—	—	UI
Generic DDR2 Inputs with Clock and Data (>10 Bits Wide) Centered at Pin (GDDR2_RX.ECLK.Centered) Using PCLK Pin for Clock Input									
Left and Right Sides									
t _{SUGDDR}	Data Setup Before CLK	ECP3-150EA	—	—	—	—	—	—	ns
t _{HGDDR}	Data Hold After CLK	ECP3-150EA	—	—	—	—	—	—	ns
f _{MAX_GDDR}	DDR2 Clock Frequency	ECP3-150EA	—	—	—	—	—	—	MHz
Generic DDR2 Inputs with Clock in the Center of Data Window, Without DLL³ (GDDR2_RX.ECLK.Centered)									
t _{SUGDDR}	Data Setup Before CLK	ECP3-70E/95E	260	—	312	—	352	—	ps
t _{HOGDDR}	Data Hold After CLK	ECP3-70E/95E	260	—	312	—	352	—	ps
f _{MAX_GDDR}	DDR/DDR2 Clock Frequency ⁸	ECP3-70E/95E	—	500	—	420	—	375	MHz
Generic DDR2 Inputs with Clock and Data (>10 Bits Wide) Aligned at Pin (GDDR2_RX.ECLK.Aligned)									
Left and Right Side Using DLLCLKIN Pin for Clock Input									
t _{DVACLKDDR}	Data Setup Before CLK (Left and Right Side)	ECP3-150EA	—	—	—	—	—	—	UI
t _{DVECLKDDR}	Data Hold After CLK (Left and Right Side)	ECP3-150EA	—	—	—	—	—	—	UI
f _{MAX_GDDR}	DDR1 Clock Frequency (Left and Right Side)	ECP3-150EA	—	—	—	—	—	—	MHz
Top Side Using PCLK Pin for Clock Input									
t _{DVACLKDDR}	Data Setup Before CLK (Top Side)	ECP3-150EA	—	—	—	—	—	—	UI
t _{DVECLKDDR}	Data Hold After CLK (Top Side)	ECP3-150EA	—	—	—	—	—	—	UI
f _{MAX_GDDR}	DDR1 Clock Frequency (Top Side)	ECP3-150EA	—	—	—	—	—	—	MHz
Generic DDR2 Inputs with Clock and Data Edges Aligned, with DLLDEL³ (GDDR2_RX.ECLK.Aligned)									
t _{DVACLKDDR}	Data Valid After CLK	ECP3-70E/95E	—	0.235	—	0.235	—	0.235	UI

LatticeECP3 External Switching Characteristics (Continued)^{1, 2}

Over Recommended Commercial Operating Conditions

Parameter	Description	Device	-8		-7		-6		Units
			Min.	Max.	Min.	Max.	Min.	Max.	
t _{DVECLKGDDR}	Data Hold After CLK	ECP3-70E/95E	0.765	—	0.765	—	0.765	—	UI
f _{MAX_GDDR}	DDR/DDR2 Clock Frequency ⁸	ECP3-70E/95E	—	500	—	420	—	375	MHz
Generic DDRX2 Inputs with Clock and Data (<10 Bits Wide) Centered at Pin (GDDR2_RX.DQS.Centered) using DQS Pin for Clock Input									
Left and Right Sides									
t _{SUGDDR}	Data Setup Before CLK	ECP3-150EA		—		—		—	ns
t _{HGDDR}	Data Hold After CLK	ECP3-150EA		—		—		—	ns
f _{MAX_GDDR}	DDR2 Clock Frequency	ECP3-150EA	—		—		—		ns
Generic DDRX2 Inputs with Clock and Data (<10 Bits Side) Aligned at Pin (GDDR2_RX.DQS.Aligned) Using DQS Pin for Clock Input									
Left and Right Sides									
t _{DVACLKGDDR}	Data Setup Before CLK (Left and Right Side)	ECP3-150EA	—		—		—		
t _{DVECLKGDDR}	Data Hold After CLK (Left and Right Side)	ECP3-150EA		—		—		—	
f _{MAX_GDDR}	DDR2 Clock Frequency (Left and Right Side)	ECP3-150EA	—		—		—		
Generic DDRX1 Output with Clock and Data (>10 Bits Wide) Centered at Pin (GDDR1_TX.SCLK.Centered)									
Left, Right and Top Sides									
t _{DVBGDDR}	Data Valid Before CLK	ECP3-150EA		—		—		—	
t _{DVAGDDR}	Data Valid After CLK	ECP3-150EA		—		—		—	
f _{MAX_GDDR}	DDR1 Clock Frequency	ECP3-150EA	—		—		—		
Generic DDRX1 Outputs with clock in the center of data window, with PLL 90-degree shifted clock output (GDDR1_TX.ECLK.Centered)									
t _{DIBGDDR}	Data Invalid Before CLK	ECP3-70E/95E	670	—	670	—	670	—	ps
t _{DIAGDDR}	Data Invalid After CLK	ECP3-70E/95E	670	—	670	—	670	—	ps
f _{MAX_GDDR}	DDR1 Clock Frequency	ECP3-70E/95E	—	250	—	250	—	250	MHz
Generic DDRX1 Output with Clock and Data (> 10 Bits Wide) Aligned at Pin (GDDR1_TX.SCLK.Aligned)									
Left, Right and Top Sides									
t _{DIBGDDR}	Data Hold After CLK	ECP3-150EA	—		—		—		
t _{DIAGDDR}	Data Setup Before CLK	ECP3-150EA	—		—		—		
f _{MAX_GDDR}	DDR1 Clock Frequency	ECP3-150EA	—		—		—		
Generic DDRX1 Outputs with clock and data edge aligned, without PLL									
t _{DIBGDDR}	Data Invalid Before CLK	ECP3-70E/95E	—	330	—	330	—	330	ps
t _{DIAGDDR}	Data Invalid After CLK	ECP3-70E/95E	—	330	—	330	—	330	ps
f _{MAX_GDDR}	DDR1 Clock Frequency	ECP3-70E/95E	—	250	—	250	—	250	MHz
Generic DDRX1 Output with Clock and Data (<10 Bits Wide) Centered at Pin (GDDR1_TX.DQS.Centered)									
Left, Right and Top Sides									
t _{DVBGDDR}	Data Valid Before CLK	ECP3-150EA	—		—		—		
t _{DVAGDDR}	Data Valid After CLK	ECP3-150EA	—		—		—		
f _{MAX_GDDR}	DDR1 Clock Frequency	ECP3-150EA	—		—		—		

LatticeECP3 External Switching Characteristics (Continued)^{1, 2}

Over Recommended Commercial Operating Conditions

Parameter	Description	Device	-8		-7		-6		Units
			Min.	Max.	Min.	Max.	Min.	Max.	
Generic DDRX2 Output with Clock and Data (> 10 Bits Wide) Aligned at Pin (GDDR2_TX.ECLK.Aligned)									
Left and Right Sides									
t _{DIBGDDR}	Data Setup Before CLK	ECP3-150EA	—		—		—		ps
t _{DIAGDDR}	Data Hold After CLK	ECP3-150EA	—		—		—		ps
f _{MAX_GDDR}	DDR/DDR2 Clock Frequency	ECP3-150EA	—		—		—		MHz
Generic DDRX2 Outputs with Clock and Data Edges Aligned, Without PLL 90-degree shifted clock output⁵ (GDDR2_TX.Aligned)									
t _{DIBGDDR}	Data Invalid Before Clock	ECP3-70E/95E	—	200	—	225	—	250	ps
t _{DIAGDDR}	Data Invalid After Clock	ECP3-70E/95E	—	200	—	225	—	250	ps
f _{MAX_GDDR}	DDR/DDR2 Clock Frequency ⁸	ECP3-70E/95E	—	500	—	420	—	375	MHz
Generic DDRX2 Output with Clock and Data (> 10 Bits Wide) Centered at Pin Using DQSDLL (GDDR2_TX.DQS-DLL.Centered)									
Left and Right Sides									
t _{DVBGDDR}	Data Valid Before CLK	ECP3-150EA		—		—		—	ns
t _{DVAGDDR}	Data Valid After CLK	ECP3-150EA		—		—		—	ns
f _{MAX_GDDR}	DDR/DDR2 Clock Frequency	ECP3-150EA	—		—		—		ns
Generic DDRX2 Output with Clock and Data (> 10 Bits Wide) Centered at Pin Using PLL (GDDR2_TX.PLL.Centered)									
Left and Right Sides									
t _{DVBGDDR}	Data Valid Before CLK	ECP3-150EA		—		—		—	ns
t _{DVAGDDR}	Data Valid After CLK	ECP3-150EA		—		—		—	ns
f _{MAX_GDDR}	DDR/DDR2 Clock Frequency	ECP3-150EA	—		—		—		ns
Generic DDRX2 Outputs with Clock Edge in the Center of Data Window, with PLL 90-degree Shifted Clock Output⁶ (GDDR2_TX.PLL.Centered)									
t _{DVBGDDR}	Data Valid Before CLK	ECP3-70E/95E	300	—	370	—	417	—	ps
t _{DVAGDDR}	Data Valid After CLK	ECP3-70E/95E	300	—	370	—	417	—	ps
f _{MAX_GDDR}	DDR/DDR2 Clock Frequency ⁸	ECP3-70E/95E	—	500	—	420	—	375	MHz

Parameter	Description	Device	-8		-7		-6		Units
			Min.	Max.	Min.	Max.	Min.	Max.	
Memory Interface									
DDR/DDR2 SDRAM I/O Pin Parameters (Input Data are Strobe Edge Aligned, Output Strobe Edge is Data Centered)⁴									
t _{DVADQ}	Data Valid After DQS (DDR Read)	ECP3-150EA	—	0.225	—	0.225	—	0.225	UI
t _{DVEDQ}	Data Hold After DQS (DDR Read)	ECP3-150EA	0.64	—	0.64	—	0.64	—	UI
t _{DQVBS}	Data Valid Before DQS	ECP3-150EA	0.25	—	0.25	—	0.25	—	UI
t _{DQVAS}	Data Valid After DQS	ECP3-150EA	0.25	—	0.25	—	0.25	—	UI
f _{MAX_DDR}	DDR Clock Frequency	ECP3-150EA	95	200	95	200	95	166	MHz
f _{MAX_DDR2}	DDR2 clock frequency	ECP3-150EA	133	266	133	200	133	166	MHz
t _{DVADQ}	Data Valid After DQS (DDR Read)	ECP3-70E/95E	—	0.225	—	0.225	—	0.225	UI
t _{DVEDQ}	Data Hold After DQS (DDR Read)	ECP3-70E/95E	0.64	—	0.64	—	0.64	—	UI
t _{DQVBS}	Data Valid Before DQS	ECP3-70E/95E	0.25	—	0.25	—	0.25	—	UI
t _{DQVAS}	Data Valid After DQS	ECP3-70E/95E	0.25	—	0.25	—	0.25	—	UI
f _{MAX_DDR}	DDR Clock Frequency	ECP3-70E/95E	95	200	95	200	95	133	MHz

LatticeECP3 External Switching Characteristics (Continued)^{1, 2}**Over Recommended Commercial Operating Conditions**

Parameter	Description	Device	-8		-7		-6		Units
			Min.	Max.	Min.	Max.	Min.	Max.	
f _{MAX_DDR2}	DDR2 Clock Frequency	ECP3-70E/95E	133	266	133	200	133	166	MHz
DDR3 (Using PLL for SCLK) I/O Pin Parameters									
t _{DVADQ}	Data Valid After DQS (DDR Read)	ECP3-150EA	—	0.225	—	0.225	—	0.225	UI
t _{DVEDQ}	Data Hold After DQS (DDR Read)	ECP3-150EA	0.64	—	0.64	—	0.64	—	UI
t _{DQVBS}	Data Valid Before DQS	ECP3-150EA	0.25	—	0.25	—	0.25	—	UI
t _{DQVAS}	Data Valid After DQS	ECP3-150EA	0.25	—	0.25	—	0.25	—	UI
f _{MAX_DDR3}	DDR3 clock frequency	ECP3-150EA	266	400	266	333	266	300	MHz

- Commercial timing numbers are shown. Industrial numbers are typically slower and can be extracted from the ispLEVER software.
- General I/O timing numbers based on LVCMOS 2.5, 12mA, 0pf load.
- Generic DDR timing numbers based on LVDS I/O.
- DDR timing numbers based on SSTL25. DDR2 timing numbers based on SSTL18.
- DDR3 timing numbers based on SSTL15.
- Uses LVDS I/O standard.
- The current version of software does not support per bank skew numbers; this will be supported in a future release.
- Maximum clock frequencies are tested under best case conditions. System performance may vary upon the user environment.

Figure 3-6. Generic DDR/DDR2 (With Clock and Data Edges Aligned)



Figure 3-7. DDR/DDR2/DDR3 SDRAM



Figure 3-8. Generic DDR/DDR2 Parameters (With Clock Center on Data Window)



LatticeECP3 Internal Switching Characteristics^{1,2}

Over Recommended Commercial Operating Conditions

Parameter	Description	-8		-7		-6		Units.
		Min.	Max.	Min.	Max.	Min.	Max.	
PFU/PFF Logic Mode Timing								
t _{LUT4_PFU}	LUT4 delay (A to D inputs to F output)	—	0.147	—	0.163	—	0.179	ns
t _{LUT6_PFU}	LUT6 delay (A to D inputs to OFX output)	—	0.273	—	0.307	—	0.342	ns
t _{LSR_PFU}	Set/Reset to output of PFU (Asynchronous)	—	0.593	—	0.674	—	0.756	ns
t _{LSRREC_PFU}	Asynchronous Set/Reset recovery time for PFU Logic	—	0.298	—	0.345	—	0.391	ns
t _{SUM_PFU}	Clock to Mux (M0,M1) Input Setup Time	0.134	—	0.144	—	0.153	—	ns
t _{HM_PFU}	Clock to Mux (M0,M1) Input Hold Time	-0.097	—	-0.103	—	-0.109	—	ns
t _{SUD_PFU}	Clock to D input setup time	0.061	—	0.068	—	0.075	—	ns
t _{HD_PFU}	Clock to D input hold time	0.019	—	0.013	—	0.015	—	ns
t _{CK2Q_PFU}	Clock to Q delay, (D-type Register Configuration)	—	0.243	—	0.273	—	0.303	ns
PFU Dual Port Memory Mode Timing								
t _{CORAM_PFU}	Clock to Output (F Port)	—	0.710	—	0.803	—	0.897	ns
t _{SUDATA_PFU}	Data Setup Time	-0.137	—	-0.155	—	-0.174	—	ns
t _{HDATA_PFU}	Data Hold Time	0.188	—	0.217	—	0.246	—	ns
t _{SUADDR_PFU}	Address Setup Time	-0.227	—	-0.257	—	-0.286	—	ns
t _{HADDR_PFU}	Address Hold Time	0.240	—	0.275	—	0.310	—	ns
t _{SUWREN_PFU}	Write/Read Enable Setup Time	-0.055	—	-0.055	—	-0.063	—	ns
t _{HWREN_PFU}	Write/Read Enable Hold Time	0.059	—	0.059	—	0.071	—	ns
PIC Timing								
PIO Input/Output Buffer Timing								
t _{IN_PIO}	Input Buffer Delay (LVCMOS25)	—	0.423	—	0.466	—	0.508	ns
t _{OUT_PIO}	Output Buffer Delay (LVCMOS25)	—	1.115	—	1.155	—	1.196	ns
IOLOGIC Input/Output Timing								
t _{SUI_PIO}	Input Register Setup Time (Data Before Clock)	0.956	—	1.124	—	1.293	—	ns
t _{HI_PIO}	Input Register Hold Time (Data after Clock)	0.313	—	0.395	—	0.378	—	ns
t _{COO_PIO}	Output Register Clock to Output Delay ⁴	—	1.455	—	1.564	—	1.674	ns
t _{SUCE_PIO}	Input Register Clock Enable Setup Time	0.220	—	0.185	—	0.150	—	ns
t _{HCE_PIO}	Input Register Clock Enable Hold Time	-0.085	—	-0.072	—	-0.058	—	ns
t _{SULSR_PIO}	Set/Reset Setup Time	0.117	—	0.103	—	0.088	—	ns
t _{HLSR_PIO}	Set/Reset Hold Time	-0.107	—	-0.094	—	-0.081	—	ns
EBR Timing								
t _{CO_EBR}	Clock (Read) to output from Address or Data	—	2.78	—	2.89	—	2.99	ns
t _{COO_EBR}	Clock (Write) to output from EBR output Register	—	0.31	—	0.32	—	0.33	ns
t _{SUDATA_EBR}	Setup Data to EBR Memory	-0.218	—	-0.227	—	-0.237	—	ns
t _{HDATA_EBR}	Hold Data to EBR Memory	0.249	—	0.257	—	0.265	—	ns
t _{SUADDR_EBR}	Setup Address to EBR Memroy	-0.071	—	-0.070	—	-0.068	—	ns
t _{HADDR_EBR}	Hold Address to EBR Memory	0.118	—	0.098	—	0.077	—	ns
t _{SUWREN_EBR}	Setup Write/Read Enable to PFU Memory	-0.107	—	-0.106	—	-0.106	—	ns

LatticeECP3 Internal Switching Characteristics^{1,2} (Continued)

Over Recommended Commercial Operating Conditions

Parameter	Description	-8		-7		-6		Units.
		Min.	Max.	Min.	Max.	Min.	Max.	
t _{HWREN_EBR}	Hold Write/Read Enable to PFU Memory	0.141	—	0.145	—	0.149	—	ns
t _{SUCE_EBR}	Clock Enable Setup Time to EBR Output Register	0.087		0.096		0.104		ns
t _{HCE_EBR}	Clock Enable Hold Time to EBR Output Register	-0.066		-0.080		-0.094		ns
t _{SUBE_EBR}	Byte Enable Set-Up Time to EBR Output Register	-0.071		-0.070		-0.068		ns
t _{HBE_EBR}	Byte Enable Hold Time to EBR Output Register	0.118		0.098		0.077		ns
DSP Block Timing³								
t _{SUI_DSP}	Input Register Setup Time	0.32	—	0.36	—	0.39	—	ns
t _{HI_DSP}	Input Register Hold Time	-0.17	—	-0.19	—	-0.21	—	ns
t _{SUP_DSP}	Pipeline Register Setup Time	2.23	—	2.30	—	2.37	—	ns
t _{HP_DSP}	Pipeline Register Hold Time	-1.02	—	-1.09	—	-1.15	—	ns
t _{SUO_DSP}	Output Register Setup Time	3.09	—	3.22	—	3.34	—	ns
t _{HO_DSP}	Output Register Hold Time	-1.67	—	-1.76	—	-1.84	—	ns
t _{COI_DSP}	Input Register Clock to Output Time	—	3.68	—	4.03	—	4.38	ns
t _{COP_DSP}	Pipeline Register Clock to Output Time	—	1.30	—	1.47	—	1.64	ns
t _{COO_DSP}	Output Register Clock to Output Time	—	0.58	—	0.60	—	0.62	ns
t _{SUOPT_DSP}	Opcod Register Setup Time	0.31	—	0.35	—	0.39	—	ns
t _{HOPT_DSP}	Opcod Register Hold Time	-0.20	—	-0.24	—	-0.27	—	ns
t _{SUDATA_DSP}	Cascade_data through ALU to Output Register Setup Time	1.55	—	1.67	—	1.78	—	ns
t _{HPDATA_DSP}	Cascade_data through ALU to Output Register Hold Time	-0.44	—	-0.53	—	-0.61	—	ns

1. Internal parameters are characterized but not tested on every device.

2. Commercial timing numbers are shown. Industrial timing numbers are typically slower and can be extracted from the ispLEVER software.

3. DSP slice is configured in Multiply Add/Sub 18x18 mode.

4. The output register is in Flip-flop mode.

Timing Diagrams

Figure 3-9. Read/Write Mode (Normal)



Note: Input data and address are registered at the positive edge of the clock and output data appears after the positive edge of the clock.

Figure 3-10. Read/Write Mode with Input and Output Registers



Figure 3-11. Write Through (SP Read/Write on Port A, Input Registers Only)



Note: Input data and address are registered at the positive edge of the clock and output data appears after the positive edge of the clock.

LatticeECP3 Family Timing Adders^{1, 2, 3, 4, 5}

Over Recommended Commercial Operating Conditions

Buffer Type	Description	-8	-7	-6	Units
Input Adjusters					
LVDS25E	LVDS, Emulated, VCCIO = 2.5V	0.03	-0.01	-0.03	ns
LVDS25	LVDS, VCCIO = 2.5V	0.03	0.00	-0.04	ns
BLVDS25	BLVDS, Emulated, VCCIO = 2.5V	0.03	0.00	-0.04	ns
MLVDS25	MLVDS, Emulated, VCCIO = 2.5V	0.03	0.00	-0.04	ns
RS25	RS25, VCCIO = 2.5V	0.03	0.00	-0.03	ns
PPLVDS	Point-to-Point LVDS	0.03	-0.01	-0.03	ns
TRLVDS	Transition-Reduced LVDS	0.03	0.00	-0.04	ns
Mini MLVDS	Mini LVDS	0.03	-0.01	-0.03	ns
LVPECL33	LVPECL, Emulated, VCCIO = 3.0V	0.17	0.07	-0.04	ns
HSTL18_I	HSTL_18 class I, VCCIO = 1.8V	0.20	0.17	0.13	ns
HSTL18_II	HSTL_18 class II, VCCIO = 1.8V	0.20	0.17	0.13	ns
HSTL18D_I	Differential HSTL 18 class I	0.20	0.17	0.13	ns
HSTL18D_II	Differential HSTL 18 class II	0.20	0.17	0.13	ns
HSTL15_I	HSTL_15 class I, VCCIO = 1.5V	0.10	0.12	0.13	ns
HSTL15D_I	Differential HSTL 15 class I	0.10	0.12	0.13	ns
SSTL33_I	SSTL_3 class I, VCCIO = 3.0V	0.17	0.23	0.28	ns
SSTL33_II	SSTL_3 class II, VCCIO = 3.0V	0.17	0.23	0.28	ns
SSTL33D_I	Differential SSTL_3 class I	0.17	0.23	0.28	ns
SSTL33D_II	Differential SSTL_3 class II	0.17	0.23	0.28	ns
SSTL25_I	SSTL_2 class I, VCCIO = 2.5V	0.12	0.14	0.16	ns
SSTL25_II	SSTL_2 class II, VCCIO = 2.5V	0.12	0.14	0.16	ns
SSTL25D_I	Differential SSTL_2 class I	0.12	0.14	0.16	ns
SSTL25D_II	Differential SSTL_2 class II	0.12	0.14	0.16	ns
SSTL18_I	SSTL_18 class I, VCCIO = 1.8V	0.08	0.06	0.04	ns
SSTL18_II	SSTL_18 class II, VCCIO = 1.8V	0.08	0.06	0.04	ns
SSTL18D_I	Differential SSTL_18 class I	0.08	0.06	0.04	ns
SSTL18D_II	Differential SSTL_18 class II	0.08	0.06	0.04	ns
SSTL15	SSTL_15, VCCIO = 1.5V	0.087	0.059	0.032	ns
SSTL15D	Differential SSTL_15	0.087	0.025	-0.036	ns
LVTTTL33	LVTTTL, VCCIO = 3.0V	0.05	0.05	0.05	ns
LVC33	LVC33, VCCIO = 3.0V	0.05	0.05	0.05	ns
LVC25	LVC25, VCCIO = 2.5V	0.00	0.00	0.00	ns
LVC18	LVC18, VCCIO = 1.8V	0.06	0.08	0.11	ns
LVC15	LVC15, VCCIO = 1.5V	0.17	0.21	0.25	ns
LVC12	LVC12, VCCIO = 1.2V	0.01	0.05	0.08	ns
PCI33	PCI, VCCIO = 3.0V	0.05	0.05	0.05	ns
Output Adjusters					
LVDS25E	LVDS, Emulated, VCCIO = 2.5V	0.15	0.15	0.16	ns
LVDS25	LVDS, VCCIO = 2.5V	0.02	0.08	0.13	ns
BLVDS25	BLVDS, Emulated, VCCIO = 2.5V	0.00	-0.02	-0.04	ns
MLVDS25	MLVDS, Emulated, VCCIO = 2.5V	0.00	-0.01	-0.03	ns

LatticeECP3 Family Timing Adders^{1, 2, 3, 4, 5} (Continued)

Over Recommended Commercial Operating Conditions

Buffer Type	Description	-8	-7	-6	Units
RS2S25	RS2S, VCCIO = 2.5V	0.05	0.10	0.16	ns
PPLVDS	Point-to-Point LVDS, Emulated, VCCIO = 2.5V	-0.10	-0.05	0.01	ns
LVPECL33	LVPECL, Emulated, VCCIO = 3.0V	-0.02	-0.04	-0.06	ns
HSTL18_I	HSTL_18 class I 8mA drive, VCCIO = 1.8V	-0.19	-0.16	-0.12	ns
HSTL18_II	HSTL_18 class II, VCCIO = 1.8V	-0.30	-0.28	-0.25	ns
HSTL18D_I	Differential HSTL 18 class I 8mA drive	-0.19	-0.16	-0.12	ns
HSTL18D_II	Differential HSTL 18 class II	-0.30	-0.28	-0.25	ns
HSTL15_I	HSTL_15 class I 4mA drive, VCCIO = 1.5V	-0.22	-0.19	-0.16	ns
HSTL15D_I	Differential HSTL 15 class I 4mA drive	-0.22	-0.19	-0.16	ns
SSTL33_I	SSTL_3 class I, VCCIO = 3.0V	0.08	0.13	0.19	ns
SSTL33_II	SSTL_3 class II, VCCIO = 3.0V	-0.20	-0.17	-0.14	ns
SSTL33D_I	Differential SSTL_3 class I	0.08	0.13	0.18	ns
SSTL33D_II	Differential SSTL_3 class II	-0.20	-0.17	-0.14	ns
SSTL25_I	SSTL_2 class I 8mA drive, VCCIO = 2.5V	-0.06	-0.02	0.02	ns
SSTL25_II	SSTL_2 class II 16mA drive, VCCIO = 2.5V	-0.19	-0.15	-0.12	ns
SSTL25D_I	Differential SSTL_2 class I 8mA drive	-0.06	-0.02	0.02	ns
SSTL25D_II	Differential SSTL_2 class II 16mA drive	-0.19	-0.15	-0.12	ns
SSTL18_I	SSTL_1.8 class I, VCCIO = 1.8V	-0.14	-0.10	-0.07	ns
SSTL18_II	SSTL_1.8 class II 8mA drive, VCCIO = 1.8V	-0.20	-0.17	-0.14	ns
SSTL18D_I	Differential SSTL_1.8 class I	-0.14	-0.10	-0.07	ns
SSTL18D_II	Differential SSTL_1.8 class II 8mA drive	-0.20	-0.17	-0.14	ns
SSTL15	SSTL_1.5, VCCIO = 1.5V	0.07	0.08	0.08	ns
SSTL15D	Differential SSTL_15	0.07	0.08	0.08	ns
LVTTTL33_4mA	LVTTTL 4mA drive, VCCIO = 3.0V	0.21	0.23	0.25	ns
LVTTTL33_8mA	LVTTTL 8mA drive, VCCIO = 3.0V	0.09	0.09	0.10	ns
LVTTTL33_12mA	LVTTTL 12mA drive, VCCIO = 3.0V	0.02	0.03	0.03	ns
LVTTTL33_16mA	LVTTTL 16mA drive, VCCIO = 3.0V	0.12	0.13	0.13	ns
LVTTTL33_20mA	LVTTTL 20mA drive, VCCIO = 3.0V	0.08	0.08	0.09	ns
LVC33_4mA	LVC33 3.3 4mA drive, fast slew rate	0.21	0.23	0.25	ns
LVC33_8mA	LVC33 3.3 8mA drive, fast slew rate	0.09	0.09	0.10	ns
LVC33_12mA	LVC33 3.3 12mA drive, fast slew rate	0.02	0.03	0.03	ns
LVC33_16mA	LVC33 3.3 16mA drive, fast slew rate	0.12	0.13	0.13	ns
LVC33_20mA	LVC33 3.3 20mA drive, fast slew rate	0.08	0.08	0.09	ns
LVC25_4mA	LVC25 2.5 4mA drive, fast slew rate	0.12	0.12	0.12	ns
LVC25_8mA	LVC25 2.5 8mA drive, fast slew rate	0.05	0.05	0.05	ns
LVC25_12mA	LVC25 2.5 12mA drive, fast slew rate	0.00	0.00	0.00	ns
LVC25_16mA	LVC25 2.5 16mA drive, fast slew rate	0.08	0.08	0.08	ns
LVC25_20mA	LVC25 2.5 20mA drive, fast slew rate	0.04	0.04	0.04	ns
LVC18_4mA	LVC18 1.8 4mA drive, fast slew rate	0.08	0.09	0.09	ns
LVC18_8mA	LVC18 1.8 8mA drive, fast slew rate	0.02	0.01	0.01	ns
LVC18_12mA	LVC18 1.8 12mA drive, fast slew rate	-0.03	-0.03	-0.03	ns
LVC18_16mA	LVC18 1.8 16mA drive, fast slew rate	0.03	0.03	0.03	ns

LatticeECP3 Family Timing Adders^{1, 2, 3, 4, 5} (Continued)

Over Recommended Commercial Operating Conditions

Buffer Type	Description	-8	-7	-6	Units
LVC MOS15_4mA	LVC MOS 1.5 4mA drive, fast slew rate	0.09	0.10	0.10	ns
LVC MOS15_8mA	LVC MOS 1.5 8mA drive, fast slew rate	0.01	0.01	0.00	ns
LVC MOS12_2mA	LVC MOS 1.2 2mA drive, fast slew rate	0.08	0.08	0.08	ns
LVC MOS12_6mA	LVC MOS 1.2 6mA drive, fast slew rate	-0.02	-0.02	-0.02	ns
LVC MOS33_4mA	LVC MOS 3.3 4mA drive, slow slew rate	1.64	1.71	1.77	ns
LVC MOS33_8mA	LVC MOS 3.3 8mA drive, slow slew rate	1.39	1.45	1.51	ns
LVC MOS33_12mA	LVC MOS 3.3 12mA drive, slow slew rate	1.21	1.27	1.33	ns
LVC MOS33_16mA	LVC MOS 3.3 16mA drive, slow slew rate	1.43	1.49	1.55	ns
LVC MOS33_20mA	LVC MOS 3.3 20mA drive, slow slew rate	1.23	1.28	1.34	ns
LVC MOS25_4mA	LVC MOS 2.5 4mA drive, slow slew rate	1.66	1.70	1.74	ns
LVC MOS25_8mA	LVC MOS 2.5 8mA drive, slow slew rate	1.39	1.43	1.46	ns
LVC MOS25_12mA	LVC MOS 2.5 12mA drive, slow slew rate	1.20	1.24	1.28	ns
LVC MOS25_16mA	LVC MOS 2.5 16mA drive, slow slew rate	1.42	1.45	1.49	ns
LVC MOS25_20mA	LVC MOS 2.5 20mA drive, slow slew rate	1.22	1.26	1.29	ns
LVC MOS18_4mA	LVC MOS 1.8 4mA drive, slow slew rate	1.61	1.65	1.68	ns
LVC MOS18_8mA	LVC MOS 1.8 8mA drive, slow slew rate	1.32	1.36	1.39	ns
LVC MOS18_12mA	LVC MOS 1.8 12mA drive, slow slew rate	1.14	1.17	1.21	ns
LVC MOS18_16mA	LVC MOS 1.8 16mA drive, slow slew rate	1.35	1.38	1.42	ns
LVC MOS15_4mA	LVC MOS 1.5 4mA drive, slow slew rate	1.57	1.60	1.64	ns
LVC MOS15_8mA	LVC MOS 1.5 8mA drive, slow slew rate	0.01	0.01	0.00	ns
LVC MOS12_2mA	LVC MOS 1.2 2mA drive, slow slew rate	1.51	1.54	1.58	ns
LVC MOS12_6mA	LVC MOS 1.2 6mA drive, slow slew rate	-0.02	-0.02	-0.02	ns
PCI33	PCI, VCCIO = 3.0V	0.19	0.21	0.24	ns

1. Timing adders are characterized but not tested on every device.
2. LVC MOS timing measured with the load specified in Switching Test Condition table.
3. All other standards tested according to the appropriate specifications.
4. Not all I/O standards and drive strengths are supported for all banks. See the Architecture section of this data sheet for details.
5. Commercial timing numbers are shown. Industrial numbers are typically slower and can be extracted from the ispLEVER software.

LatticeECP3 Maximum I/O Buffer Speed ^{1, 2, 3, 4, 5, 6}

Over Recommended Operating Conditions

Buffer	Description	Max.	Units
Maximum Input Frequency			
LVDS25	LVDS, $V_{CCIO} = 2.5V$	400	MHz
MLVDS25	MLVDS, Emulated, $V_{CCIO} = 2.5V$	400	MHz
BLVDS25	BLVDS, Emulated, $V_{CCIO} = 2.5V$	400	MHz
PPLVDS	Point-to-Point LVDS	400	MHz
TRLVDS	Transition-Reduced LVDS	612	MHz
Mini LVDS	Mini LVDS	400	MHz
LVPECL33	LVPECL, Emulated, $V_{CCIO} = 3.0V$	400	MHz
HSTL18 (all supported classed)	HSTL_18 class I, II, $V_{CCIO} = 1.8V$	400	MHz
HSTL15	HSTL_15 class I, $V_{CCIO} = 1.5V$	400	MHz
SSTL33 (all supported classed)	SSTL_3 class I, II, $V_{CCIO} = 3.0V$	400	MHz
SSTL25 (all supported classed)	SSTL_2 class I, II, $V_{CCIO} = 2.5V$	400	MHz
SSTL18 (all supported classed)	SSTL_18 class I, II, $V_{CCIO} = 1.8V$	400	MHz
LVTTTL33	LVTTTL, $V_{CCIO} = 3.0V$	166	MHz
LVC MOS33	LVC MOS, $V_{CCIO} = 3.0V$	166	MHz
LVC MOS25	LVC MOS, $V_{CCIO} = 2.5V$	166	MHz
LVC MOS18	LVC MOS, $V_{CCIO} = 1.8V$	166	MHz
LVC MOS15	LVC MOS 1.5, $V_{CCIO} = 1.5V$	166	MHz
LVC MOS12	LVC MOS 1.2, $V_{CCIO} = 1.2V$	166	MHz
PCI33	PCI, $V_{CCIO} = 3.3V$	66	MHz
Maximum Output Frequency			
LVDS25E	LVDS, Emulated, $V_{CCIO} = 2.5V$	300	MHz
LVDS25	LVDS, $V_{CCIO} = 2.5V$	612	MHz
MLVDS25	MLVDS, Emulated, $V_{CCIO} = 2.5V$	300	MHz
RS DS25	RS DS, Emulated, $V_{CCIO} = 2.5V$	612	MHz
BLVDS25	BLVDS, Emulated, $V_{CCIO} = 2.5V$	300	MHz
PPLVDS	Point-to-point LVDS	612	MHz
LVPECL33	LVPECL, Emulated, $V_{CCIO} = 3.0V$	612	MHz
Mini-LVDS	Mini LVDS	612	MHz
HSTL18 (all supported classed)	HSTL_18 class I, II, $V_{CCIO} = 1.8V$	200	MHz
HSTL15 (all supported classed)	HSTL_15 class I, $V_{CCIO} = 1.5V$	200	MHz
SSTL33 (all supported classed)	SSTL_3 class I, II, $V_{CCIO} = 3.0V$	233	MHz
SSTL25 (all supported classed)	SSTL_2 class I, II, $V_{CCIO} = 2.5V$	233	MHz
SSTL18 (all supported classed)	SSTL_18 class I, II, $V_{CCIO} = 1.8V$	266	MHz
LVTTTL33	LVTTTL, $V_{CCIO} = 3.0V$	166	MHz
LVC MOS33 (For all drives)	LVC MOS, 3.3V	166	MHz
LVC MOS25 (For all drives)	LVC MOS, 2.5V	166	MHz
LVC MOS18 (For all drives)	LVC MOS, 1.8V	166	MHz
LVC MOS15 (For all drives)	LVC MOS, 1.5V	166	MHz
LVC MOS12 (For all drives except 2mA)	LVC MOS, $V_{CCIO} = 1.2V$	166	MHz
LVC MOS12 (2mA drive)	LVC MOS, $V_{CCIO} = 1.2V$	100	MHz

LatticeECP3 Maximum I/O Buffer Speed (Continued)^{1, 2, 3, 4, 5, 6}

Over Recommended Operating Conditions

Buffer	Description	Max.	Units
PCI33	PCI, $V_{CCIO} = 3.3V$	66	MHz

1. These maximum speeds are characterized but not tested on every device.
2. Maximum I/O speed for differential output standards emulated with resistors depends on the layout.
3. LVCMOS timing is measured with the load specified in the Switching Test Conditions table of this document.
4. All speeds are measured at fast slew.
5. Actual system operation may vary depending on user logic implementation.
6. Maximum data rate equals 2 times the clock rate when utilizing DDR.

sysCLOCK PLL Timing**Over Recommended Operating Conditions**

Parameter	Descriptions	Conditions	Clock	Min.	Typ.	Max.	Units	
f _{IN}	Input clock frequency (CLKI, CLKFB)		Edge clock	2	—	500	MHz	
			Primary clock	2	—	420	MHz	
f _{OUT}	Output clock frequency (CLKOP, CLKOS)		Edge clock	4	—	500	MHz	
			Primary clock	4	—	420	MHz	
f _{OUT1}	K-Divider output frequency	CLKOK		0.03125	—	250	MHz	
f _{OUT2}	K2-Divider output frequency	CLKOK2		0.667	—	166	MHz	
f _{VCO}	PLL VCO frequency			500	—	1000	MHz	
f _{PDF} ³	Phase detector input frequency		Edge clock	2	—	500	MHz	
			Primary clock	2	—	420	MHz	
AC Characteristics								
t _{PA}	Programmable delay unit			65	130	260	ps	
t _{DT}	Output clock duty cycle (CLKOS, at 50% setting)		Edge clock	45	50	55	%	
			f _{OUT} ≤ 250 MHz	Primary clock	45	50	55	%
			f _{OUT} > 250MHz	Primary clock	30	50	70	%
t _{CFA}	Coarse phase shift error (CLKOS, at all settings)			-5	0	+5	% of period	
t _{OPW}	Output clock pulse width high or low (CLKOS)			1.8	—	—	ns	
t _{OPJIT} ¹	Output clock period jitter	f _{OUT} ≥ 420MHz		—	—	200	p-p	
		420MHz > f _{OUT} ≥ 100MHz		—	—	250	p-p	
		f _{OUT} < 100MHz		—	—	0.025	UIPP	
t _{SK}	Input clock to output clock skew when N/M = integer			—	—	500	p-p	
t _{LOCK} ²	Lock time	2 to 25 MHz		—	—	200	us	
		25 to 500 MHz		—	—	50	us	
t _{UNLOCK}	Reset to PLL unlock time to ensure fast reset			—	—	50	ns	
t _{HI}	Input clock high time	90% to 90%		0.5	—	—	ns	
t _{LO}	Input clock low time	10% to 10%		0.5	—	—	ns	
t _{IPJIT}	Input clock period jitter			—	—	400	p-p	
t _{RST}	Reset signal pulse width high, RESETM, RESETK			10	—	—	ns	
	Reset signal pulse width high, CNTRST			500	—	—	ns	

1. Jitter sample is taken over 10,000 samples of the primary PLL output with clean reference clock with no additional I/O toggling.

2. Output clock is valid after t_{LOCK} for PLL reset and dynamic delay adjustment.

3. Period jitter and cycle-to-cycle jitter numbers are guaranteed for f_{PDF} > 4MHz. For f_{PDF} < 4MHz, the jitter numbers may not be met in certain conditions. Please contact the factory for f_{PDF} < 4MHz.

DLL Timing

Over Recommended Operating Conditions

Parameter	Description	Condition	Min.	Typ.	Max.	Units
f_{REF}	Input reference clock frequency (on-chip or off-chip)		133	—	500	MHz
f_{FB}	Feedback clock frequency (on-chip or off-chip)		133	—	500	MHz
f_{CLKOP}^1	Output clock frequency, CLKOP		133	—	500	MHz
f_{CLKOS}^2	Output clock frequency, CLKOS		33.3	—	500	MHz
t_{PJIT}	Output clock period jitter (clean input)			—	200	ps p-p
t_{DUTY}	Output clock duty cycle (at 50% levels, 50% duty cycle input clock, 50% duty cycle circuit turned off, time reference delay mode)	Edge Clock	40		60	%
		Primary Clock	30		70	%
$t_{DUTYTRD}$	Output clock duty cycle (at 50% levels, arbitrary duty cycle input clock, 50% duty cycle circuit enabled, time reference delay mode)	Primary Clock < 250MHz	45		55	%
		Primary Clock \geq 250MHz	30		70	%
		Edge Clock	45		55	%
$t_{DUTYCIR}$	Output clock duty cycle (at 50% levels, arbitrary duty cycle input clock, 50% duty cycle circuit enabled, clock injection removal mode) with DLL cascading	Primary Clock < 250MHz	40		60	%
		Primary Clock \geq 250MHz	30		70	%
		Edge Clock	45		55	%
t_{SKEW}^3	Output clock to clock skew between two outputs with the same phase setting		—	—	100	ps
t_{PHASE}	Phase error measured at device pads between off-chip reference clock and feedback clocks		—	—	+/-400	ps
t_{PWH}	Input clock minimum pulse width high (at 80% level)		550	—	—	ps
t_{PWL}	Input clock minimum pulse width low (at 20% level)		550	—	—	ps
t_{INSTB}	Input clock period jitter		—	—	500	p-p
t_{LOCK}	DLL lock time		8	—	8200	cycles
t_{RSWD}	Digital reset minimum pulse width (at 80% level)		3	—	—	ns
t_{DEL}	Delay step size		27	45	70	ps
t_{RANGE1}	Max. delay setting for single delay block (64 taps)		1.9	3.1	4.4	ns
t_{RANGE4}	Max. delay setting for four chained delay blocks		7.6	12.4	17.6	ns

1. CLKOP runs at the same frequency as the input clock.

2. CLKOS minimum frequency is obtained with divide by 4.

3. This is intended to be a “path-matching” design guideline and is not a measurable specification.

SERDES High-Speed Data Transmitter¹

Table 3-6. Serial Output Timing and Levels

Symbol	Description	Frequency	Min.	Typ.	Max.	Units
V _{TX-DIFF-P-P-1.44}	Differential swing (1.44V setting) ^{1, 2}	0.25 to 3.125 Gbps	1150	1440	1730	mV, p-p
V _{TX-DIFF-P-P-1.35}	Differential swing (1.35V setting) ^{1, 2}	0.25 to 3.125 Gbps	1080	1350	1620	mV, p-p
V _{TX-DIFF-P-P-1.26}	Differential swing (1.26V setting) ^{1, 2}	0.25 to 3.125 Gbps	1000	1260	1510	mV, p-p
V _{TX-DIFF-P-P-1.13}	Differential swing (1.13V setting) ^{1, 2}	0.25 to 3.125 Gbps	840	1130	1420	mV, p-p
V _{TX-DIFF-P-P-1.04}	Differential swing (1.04V setting) ^{1, 2}	0.25 to 3.125 Gbps	780	1040	1300	mV, p-p
V _{TX-DIFF-P-P-0.92}	Differential swing (0.92V setting) ^{1, 2}	0.25 to 3.125 Gbps	690	920	1150	mV, p-p
V _{TX-DIFF-P-P-0.87}	Differential swing (0.87V setting) ^{1, 2}	0.25 to 3.125 Gbps	650	870	1090	mV, p-p
V _{TX-DIFF-P-P-0.78}	Differential swing (0.78V setting) ^{1, 2}	0.25 to 3.125 Gbps	585	780	975	mV, p-p
V _{TX-DIFF-P-P-0.64}	Differential swing (0.64V setting) ^{1, 2}	0.25 to 3.125 Gbps	480	640	800	mV, p-p
V _{OCM}	Output common mode voltage	—	V _{CCOB} -0.75	V _{CCOB} -0.60	V _{CCOB} -0.45	V
T _{TX-R}	Rise time (20% to 80%)	—	145	185	265	ps
T _{TX-F}	Fall time (80% to 20%)	—	145	185	265	ps
Z _{TX-OI-SE}	Output Impedance 50/75/HiZ Ohms (single ended)	—	-20%	50/75/ Hi Z	+20%	Ohms
R _{LTX-RL}	Return loss (with package)	—	10			dB
T _{TX-INTRASKEW}	Lane-to-lane TX skew within a SERDES quad block (intra-quad)	—	—	—	200	ps
T _{TX-INTERSKEW} ³	Lane-to-lane skew between SERDES quad blocks (inter-quad)	—	—	—	1UI +200	ps

1. All measurements are with 50 ohm impedance.

2. See TN1176, [LatticeECP3 SERDES/PCS Usage Guide](#) for actual binary settings and the min-max range.

3. Inter-quad skew is between all SERDES channels on the device and requires the use of a low skew internal reference clock.

Table 3-7. Channel Output Jitter

Description	Frequency	Min.	Typ.	Max.	Units
Deterministic	3.125 Gbps	—	—	0.17	UI, p-p
Random	3.125 Gbps	—	—	0.25	UI, p-p
Total	3.125 Gbps	—	—	0.35	UI, p-p
Deterministic	2.5Gbps	—	—	0.17	UI, p-p
Random	2.5Gbps	—	—	0.20	UI, p-p
Total	2.5Gbps	—	—	0.35	UI, p-p
Deterministic	1.25 Gbps	—	—	0.10	UI, p-p
Random	1.25 Gbps	—	—	0.22	UI, p-p
Total	1.25 Gbps	—	—	0.24	UI, p-p
Deterministic	622 Mbps	—	—	0.10	UI, p-p
Random	622 Mbps	—	—	0.20	UI, p-p
Total	622 Mbps	—	—	0.24	UI, p-p
Deterministic	250 Mbps	—	—	0.10	UI, p-p
Random	250 Mbps	—	—	0.18	UI, p-p
Total	250 Mbps	—	—	0.24	UI, p-p

Note: Values are measured with PRBS 2⁷-1, all channels operating, FPGA logic active, I/Os around SERDES pins quiet, reference clock @ 10X mode.

SERDES/PCS Block Latency

Table 3-8 describes the latency of each functional block in the transmitter and receiver. Latency is given in parallel clock cycles. Figure 3-12 shows the location of each block.

Table 3-8. SERDES/PCS Latency Breakdown

Item	Description	Min.	Avg.	Max.	Fixed	Bypass	Units
Transmit Data Latency¹							
T1	FPGA Bridge - Gearing disabled with different clocks	1	3	5	—	1	word clk
	FPGA Bridge - Gearing disabled with same clocks	—	—	—	3	1	word clk
	FPGA Bridge - Gearing enabled	1	3	5	—	—	word clk
T2	8b10b Encoder	—	—	—	2	1	word clk
T3	SERDES Bridge transmit	—	—	—	2	1	word clk
T4	Serializer: 8-bit mode	—	—	—	15 + Δ1	—	UI + ps
	Serializer: 10-bit mode	—	—	—	18 + Δ1	—	UI + ps
T5	Pre-emphasis ON	—	—	—	1 + Δ2	—	UI + ps
	Pre-emphasis OFF	—	—	—	0 + Δ3	—	UI + ps
Receive Data Latency²							
R1	Equalization ON	—	—	—	Δ1	—	UI + ps
	Equalization OFF	—	—	—	Δ2	—	UI + ps
R2	Deserializer: 8-bit mode	—	—	—	10 + Δ3	—	UI + ps
	Deserializer: 10-bit mode	—	—	—	12 + Δ3	—	UI + ps
R3	SERDES Bridge receive	—	—	—	2	—	word clk
R4	Word alignment	3.1	—	4	—	—	word clk
R5	8b10b decoder	—	—	—	1	—	word clk
R6	Clock Tolerance Compensation	7	15	23	1	1	word clk
R7	FPGA Bridge - Gearing disabled with different clocks	1	3	5	—	1	word clk
	FPGA Bridge - Gearing disabled with same clocks	—	—	—	3	1	word clk
	FPGA Bridge - Gearing enabled	1	3	5	—	—	word clk

1. Δ1 = -245ps, Δ2 = +88ps, Δ3 = +112ps.
2. Δ1 = +118ps, Δ2 = +132ps, Δ3 = +700ps.

Figure 3-12. Transmitter and Receiver Latency Block Diagram



SERDES High Speed Data Receiver

Table 3-9. Serial Input Data Specifications

Symbol	Description	Min.	Typ.	Max.	Units	
RX-CID _S	Stream of nontransitions ¹ (CID = Consecutive Identical Digits) @ 10 ⁻¹² BER	3.125G	—	—	136	Bits
		2.5G	—	—	144	
		1.485G	—	—	160	
		622M	—	—	204	
		270M	—	—	228	
		155M	—	—	296	
V _{RX-DIFF-S}	Differential input sensitivity	150	—	1760	mV, p-p	
V _{RX-IN}	Input levels	0	—	V _{CCA} +0.5 ⁴	V	
V _{RX-CM-DC}	Input common mode range (DC coupled)	0.6	—	V _{CCA}	V	
V _{RX-CM-AC}	Input common mode range (AC coupled) ³	0.1	—	V _{CCA} +0.2	V	
T _{RX-RELOCK}	SCDR re-lock time ²	—	1000	—	Bits	
Z _{RX-TERM}	Input termination 50/75 Ohm/High Z	-20%	50/75/HiZ	+20%	Ohms	
RL _{RX-RL}	Return loss (without package)	10	—	—	dB	

1. This is the number of bits allowed without a transition on the incoming data stream when using DC coupling.
2. This is the typical number of bit times to re-lock to a new phase or frequency within +/- 300 ppm, assuming 8b10b encoded data.
3. AC coupling is used to interface to LVPECL and LVDS. LVDS interfaces are found in laser drivers and Fibre Channel equipment. LVDS interfaces are generally found in 622 Mbps SERDES devices.
4. Up to 1.76V.

Input Data Jitter Tolerance

A receiver's ability to tolerate incoming signal jitter is very dependent on jitter type. High speed serial interface standards have recognized the dependency on jitter type and have specifications to indicate tolerance levels for different jitter types as they relate to specific protocols. Sinusoidal jitter is considered to be a worst case jitter type.

Table 3-10. Receiver Total Jitter Tolerance Specification

Description	Frequency	Condition	Min.	Typ.	Max.	Units
Deterministic	3.125 Gbps	600 mV differential eye	—	—	0.47	UI, p-p
Random		600 mV differential eye	—	—	0.18	UI, p-p
Total		600 mV differential eye	—	—	0.65	UI, p-p
Deterministic	2.5 Gbps	600 mV differential eye	—	—	0.47	UI, p-p
Random		600 mV differential eye	—	—	0.18	UI, p-p
Total		600 mV differential eye	—	—	0.65	UI, p-p
Deterministic	1.25 Gbps	600 mV differential eye	—	—	0.47	UI, p-p
Random		600 mV differential eye	—	—	0.18	UI, p-p
Total		600 mV differential eye	—	—	0.65	UI, p-p
Deterministic	622 Mbps	600 mV differential eye	—	—	0.47	UI, p-p
Random		600 mV differential eye	—	—	0.18	UI, p-p
Total		600 mV differential eye	—	—	0.65	UI, p-p

Note: Values are measured with CJPAT, all channels operating, FPGA Logic active, I/Os around SERDES pins quiet, voltages are nominal, room temperature.

Table 3-11. Periodic Receiver Jitter Tolerance Specification

Description	Frequency	Condition	Min.	Typ.	Max.	Units
Periodic	2.97 Gbps	600 mV differential eye	—	—	0.24	UI, p-p
Periodic	2.5 Gbps	600 mV differential eye	—	—	0.22	UI, p-p
Periodic	1.485 Gbps	600 mV differential eye	—	—	0.24	UI, p-p
Periodic	622 Mbps	600 mV differential eye	—	—	0.15	UI, p-p
Periodic	155 Mbps	600 mV differential eye	—	—	0.5	UI, p-p

Note: Values are measured with PRBS 2⁷-1, all channels operating, FPGA Logic active, I/Os around SERDES pins quiet, voltages are nominal, room temperature.

SERDES External Reference Clock

The external reference clock selection and its interface are a critical part of system applications for this product. Table 3-12 specifies reference clock requirements, over the full range of operating conditions.

Table 3-12. External Reference Clock Specification (refclkp/refclkn)

Symbol	Description	Min.	Typ.	Max.	Units
F _{REF}	Frequency range	15	—	320	MHz
F _{REF-PPM}	Frequency tolerance ⁴	-1000	—	1000	ppm
V _{REF-IN-SE}	Input swing, single-ended clock ¹	200	—	V _{CCA}	mV, p-p
V _{REF-IN-DIFF}	Input swing, differential clock	200	—	2*V _{CCA}	mV, p-p differential
V _{REF-IN}	Input levels	0	—	V _{CCA} + 0.3	V
V _{REF-CM-AC}	Input common mode range (AC coupled) ²	0.125	—	V _{CCA}	V
D _{REF}	Duty cycle ³	40	—	60	%
T _{REF-R}	Rise time (20% to 80%)	200	500	1000	ps
T _{REF-F}	Fall time (80% to 20%)	200	500	1000	ps
Z _{REF-IN-TERM-DIFF}	Differential input termination	-20%	100/2K	+20%	Ohms
C _{REF-IN-CAP}	Input capacitance	—	—	7	pF

1. The signal swing for a single-ended input clock must be as large as the p-p differential swing of a differential input clock to get the same gain at the input receiver. Lower swings for the clock may be possible, but will tend to increase jitter.
2. When AC coupled, the input common mode range is determined by:
(Min input level) + (Peak-to-peak input swing)/2 ≤ (Input common mode voltage) ≤ (Max input level) - (Peak-to-peak input swing)/2
3. Measured at 50% amplitude.
4. Depending on the application, the PLL_LOL_SET and CDR_LOL_SET control registers may be adjusted for other tolerance values as described in TN1176, [LatticeECP3 SERDES/PCS Usage Guide](#).

Figure 3-13. SERDES External Reference Clock Waveforms



PCI Express Electrical and Timing Characteristics

AC and DC Characteristics

Over Recommended Operating Conditions

Symbol	Description	Test Conditions	Min	Typ	Max	Units
Transmit¹						
UI	Unit interval		399.88	400	400.12	ps
$V_{TX-DIFF_P-P}$	Differential peak-to-peak output voltage		0.8	1.0	1.2	V
$V_{TX-DE-RATIO}$	De-emphasis differential output voltage ratio		-3	-3.5	-4	dB
$V_{TX-CM-AC_P}$	RMS AC peak common-mode output voltage		—	—	20	mV
$V_{TX-RCV-DETECT}$	Amount of voltage change allowed during receiver detection		—	—	600	mV
$V_{TX-DC-CM}$	Tx DC common mode voltage		0	—	$V_{CCOB} + 5\%$	V
$I_{TX-SHORT}$	Output short circuit current	$V_{TX-D+}=0.0V$ $V_{TX-D-}=0.0V$	—	—	90	mA
$Z_{TX-DIFF-DC}$	Differential output impedance		80	100	120	Ohms
$RL_{TX-DIFF}$	Differential return loss		10	—	—	dB
RL_{TX-CM}	Common mode return loss		6.0	—	—	dB
$T_{TX-RISE}$	Tx output rise time	20 to 80%	0.125	—	—	UI
$T_{TX-FALL}$	Tx output fall time	20 to 80%	0.125	—	—	UI
$L_{TX-SKEW}$	Lane-to-lane static output skew for all lanes in port/link		—	—	1.3	ns
T_{TX-EYE}	Transmitter eye width		0.75	—	—	UI
$T_{TX-EYE-MEDIAN-TO-MAX-JITTER}$	Maximum time between jitter median and maximum deviation from median		—	—	0.125	UI
Receive^{1,2}						
UI	Unit Interval		399.88	400	400.12	ps
$V_{RX-DIFF_P-P}$	Differential peak-to-peak input voltage		0.34 ³	—	1.2	V
$V_{RX-IDLE-DET-DIFF_P-P}$	Idle detect threshold voltage		65	—	340 ³	mV
$V_{RX-CM-AC_P}$	Receiver common mode voltage for AC coupling		—	—	150	mV
$Z_{RX-DIFF-DC}$	DC differential input impedance		80	100	120	Ohms
Z_{RX-DC}	DC input impedance		40	50	60	Ohms
$Z_{RX-HIGH-IMP-DC}$	Power-down DC input impedance		200K	—	—	Ohms
$RL_{RX-DIFF}$	Differential return loss		10	—	—	dB
RL_{RX-CM}	Common mode return loss		6.0	—	—	dB
$T_{RX-IDLE-DET-DIFF-ENTERTIME}$	Maximum time required for receiver to recognize and signal an unexpected idle on link		—	—	—	ms

1. Values are measured at 2.5 Gbps.

2. Measured with external AC-coupling on the receiver.

3. Not in compliance with PCI Express 1.1 standard.

XAUI/Serial Rapid I/O Type 3 Electrical and Timing Characteristics**AC and DC Characteristics****Table 3-13. Transmit****Over Recommended Operating Conditions**

Symbol	Description	Test Conditions	Min.	Typ.	Max.	Units
T_{RF}	Differential rise/fall time	20%-80%	—	80	—	ps
$Z_{TX_DIFF_DC}$	Differential impedance		80	100	120	Ohms
$J_{TX_DDJ}^{2,3,4}$	Output data deterministic jitter		—	—	0.17	UI
$J_{TX_TJ}^{1,2,3,4}$	Total output data jitter		—	—	0.35	UI

1. Total jitter includes both deterministic jitter and random jitter.
2. Jitter values are measured with each CML output AC coupled into a 50-ohm impedance (100-ohm differential impedance).
3. Jitter and skew are specified between differential crossings of the 50% threshold of the reference signal.
4. Values are measured at 2.5 Gbps.

Table 3-14. Receive and Jitter Tolerance**Over Recommended Operating Conditions**

Symbol	Description	Test Conditions	Min.	Typ.	Max.	Units
RL_{RX_DIFF}	Differential return loss	From 100 MHz to 3.125 GHz	10	—	—	dB
RL_{RX_CM}	Common mode return loss	From 100 MHz to 3.125 GHz	6	—	—	dB
Z_{RX_DIFF}	Differential termination resistance		80	100	120	Ohms
$J_{RX_DJ}^{1,2,3}$	Deterministic jitter tolerance (peak-to-peak)		—	—	0.37	UI
$J_{RX_RJ}^{1,2,3}$	Random jitter tolerance (peak-to-peak)		—	—	0.18	UI
$J_{RX_SJ}^{1,2,3}$	Sinusoidal jitter tolerance (peak-to-peak)		—	—	0.10	UI
$J_{RX_TJ}^{1,2,3}$	Total jitter tolerance (peak-to-peak)		—	—	0.65	UI
T_{RX_EYE}	Receiver eye opening		0.35	—	—	UI

1. Total jitter includes deterministic jitter, random jitter and sinusoidal jitter. The sinusoidal jitter tolerance mask is shown in Figure 3-14.
2. Jitter values are measured with each high-speed input AC coupled into a 50-ohm impedance.
3. Jitter and skew are specified between differential crossings of the 50% threshold of the reference signal.
4. Jitter tolerance parameters are characterized when Full Rx Equalization is enabled.
5. Values are measured at 2.5 Gbps.

Figure 3-14. XAUI Sinusoidal Jitter Tolerance Mask



Note: The sinusoidal jitter tolerance is measured with at least 0.37UIpp of Deterministic jitter (Dj) and the sum of Dj and Rj (random jitter) is at least 0.55UIpp. Therefore, the sum of Dj, Rj and Sj (sinusoidal jitter) is at least 0.65UIpp (Dj = 0.37, Rj = 0.18, Sj = 0.1).

Serial Rapid I/O Type 2 Electrical and Timing Characteristics

AC and DC Characteristics

Table 3-15. Transmit

Symbol	Description	Test Conditions	Min.	Typ.	Max.	Units
T_{RF}^1	Differential rise/fall time	20%-80%	—	80	—	ps
$Z_{TX_DIFF_DC}$	Differential impedance		80	100	120	Ohms
$J_{TX_DDJ}^{3,4,5}$	Output data deterministic jitter		—	—	0.17	UI
$J_{TX_TJ}^{2,3,4,5}$	Total output data jitter		—	—	0.35	UI

1. Rise and Fall times measured with board trace, connector and approximately 2.5pf load.
2. Total jitter includes both deterministic jitter and random jitter. The random jitter is the total jitter minus the actual deterministic jitter.
3. Jitter values are measured with each CML output AC coupled into a 50-ohm impedance (100-ohm differential impedance).
4. Jitter and skew are specified between differential crossings of the 50% threshold of the reference signal.
5. Values are measured at 2.5 Gbps.

Table 3-16. Receive and Jitter Tolerance

Symbol	Description	Test Conditions	Min.	Typ.	Max.	Units
RL_{RX_DIFF}	Differential return loss	From 100 MHz to 2.5 GHz	10	—	—	dB
RL_{RX_CM}	Common mode return loss	From 100 MHz to 2.5 GHz	6	—	—	dB
Z_{RX_DIFF}	Differential termination resistance		80	100	120	Ohms
$J_{RX_DJ}^{2,3,4,5}$	Deterministic jitter tolerance (peak-to-peak)		—	—	0.37	UI
$J_{RX_RJ}^{2,3,4,5}$	Random jitter tolerance (peak-to-peak)		—	—	0.18	UI
$J_{RX_SJ}^{2,3,4,5}$	Sinusoidal jitter tolerance (peak-to-peak)		—	—	0.10	UI
$J_{RX_TJ}^{1,2,3,4,5}$	Total jitter tolerance (peak-to-peak)		—	—	0.65	UI
T_{RX_EYE}	Receiver eye opening		0.35	—	—	UI

1. Total jitter includes deterministic jitter, random jitter and sinusoidal jitter. The sinusoidal jitter tolerance mask is shown in Figure 3-14.
2. Jitter values are measured with each high-speed input AC coupled into a 50-ohm impedance.
3. Jitter and skew are specified between differential crossings of the 50% threshold of the reference signal.
4. Jitter tolerance, Differential Input Sensitivity and Receiver Eye Opening parameters are characterized when Full Rx Equalization is enabled.
5. Values are measured at 2.5 Gbps.

Gigabit Ethernet/Serial Rapid I/O Type 1/SGMII Electrical and Timing Characteristics

AC and DC Characteristics

Table 3-17. Transmit

Symbol	Description	Test Conditions	Min.	Typ.	Max.	Units
T_{RF}	Differential rise/fall time	20%-80%	—	80	—	ps
$Z_{TX_DIFF_DC}$	Differential impedance		80	100	120	Ohms
$J_{TX_DDJ}^{3,4,5}$	Output data deterministic jitter		—	—	0.10	UI
$J_{TX_TJ}^{2,3,4,5}$	Total output data jitter		—	—	0.24	UI

1. Rise and fall times measured with board trace, connector and approximately 2.5pf load.
2. Total jitter includes both deterministic jitter and random jitter. The random jitter is the total jitter minus the actual deterministic jitter.
3. Jitter values are measured with each CML output AC coupled into a 50-ohm impedance (100-ohm differential impedance).
4. Jitter and skew are specified between differential crossings of the 50% threshold of the reference signal.
5. Values are measured at 1.25 Gbps.

Table 3-18. Receive and Jitter Tolerance

Symbol	Description	Test Conditions	Min.	Typ.	Max.	Units
RL_{RX_DIFF}	Differential return loss	From 100 MHz to 1.25 GHz	10	—	—	dB
RL_{RX_CM}	Common mode return loss	From 100 MHz to 1.25 GHz	6	—	—	dB
Z_{RX_DIFF}	Differential termination resistance		80	100	120	Ohms
$J_{RX_DJ}^{1,2,3,4,5}$	Deterministic jitter tolerance (peak-to-peak)		—	—	0.34	UI
$J_{RX_RJ}^{1,2,3,4,5}$	Random jitter tolerance (peak-to-peak)		—	—	0.26	UI
$J_{RX_SJ}^{1,2,3,4,5}$	Sinusoidal jitter tolerance (peak-to-peak)		—	—	0.11	UI
$J_{RX_TJ}^{1,2,3,4,5}$	Total jitter tolerance (peak-to-peak)		—	—	0.71	UI
T_{RX_EYE}	Receiver eye opening		0.29	—	—	UI

1. Total jitter includes deterministic jitter, random jitter and sinusoidal jitter. The sinusoidal jitter tolerance mask is shown in Figure 3-14.
2. Jitter values are measured with each high-speed input AC coupled into a 50-ohm impedance.
3. Jitter and skew are specified between differential crossings of the 50% threshold of the reference signal.
4. Jitter tolerance, Differential Input Sensitivity and Receiver Eye Opening parameters are characterized when Full Rx Equalization is enabled.
5. Values are measured at 1.25 Gbps.

SMPTE SD/HD-SDI/3G-SDI (Serial Digital Interface) Electrical and Timing Characteristics

AC and DC Characteristics

Table 3-19. Transmit

Symbol	Description	Test Conditions	Min.	Typ.	Max.	Units
BR _{SDO}	Serial data rate		270	—	2975	Mbps
T _{JALIGNMENT} ²	Serial output jitter, alignment	270 Mbps	—	—	0.20	UI
T _{JALIGNMENT} ²	Serial output jitter, alignment	1485 Mbps	—	—	0.20	UI
T _{JALIGNMENT} ^{1,2}	Serial output jitter, alignment	2970Mbps	—	—	0.30	UI
T _{JTIMING}	Serial output jitter, timing	270 Mbps	—	—	0.20	UI
T _{JTIMING}	Serial output jitter, timing	1485 Mbps	—	—	1.0	UI
T _{JTIMING}	Serial output jitter, timing	2970 Mbps	—	—	2.0	UI

Notes:

- Timing jitter is measured in accordance with SMPTE RP 184-1996, SMPTE RP 192-1996 and the applicable serial data transmission standard, SMPTE 259M-1997 or SMPTE 292M (proposed). A color bar test pattern is used. The value of f_{SCLK} is 270 MHz or 360 MHz for SMPTE 259M, 540 MHz for SMPTE 344M or 1485 MHz for SMPTE 292M serial data rates. See the Timing Jitter Bandpass section.
- Jitter is defined in accordance with SMPTE RP1 184-1996 as: jitter at an equipment output in the absence of input jitter.
- All Tx jitter is measured at the output of an industry standard cable driver; connection to the cable driver is via a 50 ohm impedance differential signal from the Lattice SERDES device.
- The cable driver drives: RL=75 ohm, AC-coupled at 270, 1485, or 2970 Mbps, RREFVLV=RREFPRE=4.75kohm 1%.

Table 3-20. Receive

Symbol	Description	Test Conditions	Min.	Typ.	Max.	Units
BR _{SDI}	Serial input data rate		270	—	2970	Mbps
CID	Stream of non-transitions (=Consecutive Identical Digits)		7(3G)/26(SMPTE Triple rates) @ 10-12 BER	—	—	Bits

Table 3-21. Reference Clock

Symbol	Description	Test Conditions	Min.	Typ.	Max.	Units
F _{VCLK}	Video output clock frequency		27	—	74.25	MHz
DC _V	Duty cycle, video clock		45	50	55	%

HDMI (High-Definition Multimedia Interface) Electrical and Timing Characteristics

AC and DC Characteristics

Table 3-22. Transmit and Receive^{1,2}

Symbol	Description	Spec. Compliance		Units
		Min. Spec.	Max. Spec.	
Transmit				
Intra-pair Skew		—	75	ps
Inter-pair Skew		—	800	ps
TMDS Differential Clock Jitter		—	0.25	UI
Receive				
R_T	Termination Resistance	40	60	Ohms
V_{ICM}	Input AC Common Mode Voltage (50-ohm Setting)	—	50	mV
TMDS Clock Jitter	Clock Jitter Tolerance	—	0.25	UI

1. Output buffers must drive a translation device. Max. speed is 2Gbps. If translation device does not modify rise/fall time, the maximum speed is 1.5Gbps.
2. Input buffers must be AC coupled in order to support the 3.3V common mode. Generally, HDMI inputs are terminated by an external cable equalizer before data/clock is forwarded to the LatticeECP3 device.

Figure 3-15. Test Loads

Test Loads



C_L including probe and jig capacitance, 3pF max.
 S_1 - open, S_2 - closed for V_{OH} measurement.
 S_1 - closed, S_2 - open for V_{OL} measurement.



*Risetime compensation.

Timing Jitter Bandpass



LatticeECP3 sysCONFIG Port Timing Specifications

Over Recommended Operating Conditions

Parameter	Description	Min.	Max.	Units	
POR, Configuration Initialization, and Wakeup					
t_{ICFG}	Time from the Application of V_{CC} , V_{CCAUX} or V_{CCIO8}^* (Whichever is the Last to Cross the POR Trip Point) to the Rising Edge of INITN	Master mode	—	23	ms
		Slave mode	—	6	ms
t_{VMC}	Time from t_{ICFG} to the Valid Master MCLK	—	5	μ s	
t_{PRGM}	PROGRAMN Low Time to Start Configuration	25	—	ns	
t_{PRGMRJ}	PROGRAMN Pin Pulse Rejection	—	10	ns	
$t_{DPPINIT}$	Delay Time from PROGRAMN Low to INITN Low	—	37	ns	
$t_{DPPDONE}$	Delay Time from PROGRAMN Low to DONE Low	—	37	ns	
t_{DINIT}	PROGRAMN High to INITN High Delay	—	1	ms	
t_{MWC}	Additional Wake Master Clock Signals After DONE Pin is High	100	500	cycles	
t_{CZ}	MCLK From Active To Low To High-Z	—	300	ns	
All Configuration Modes					
t_{SUCDI}	Data Setup Time to CCLK/MCLK	5	—	ns	
t_{HCDI}	Data Hold Time to CCLK/MCLK	1	—	ns	
t_{CODO}	CCLK/MCLK to DOUT in Flowthrough Mode	—	12	ns	
Slave Serial					
t_{SSCH}	CCLK Minimum High Pulse	5	—	ns	
t_{SSCL}	CCLK Minimum Low Pulse	5	—	ns	
f_{CCLK}	CCLK Frequency	Without encryption	—	33	MHz
		With encryption	—	20	MHz
Master and Slave Parallel					
t_{SUCS}	CSN[1:0] Setup Time to CCLK/MCLK	7	—	ns	
t_{HCS}	CSN[1:0] Hold Time to CCLK/MCLK	1	—	ns	
t_{SUWD}	WRITEN Setup Time to CCLK/MCLK	7	—	ns	
t_{HWD}	WRITEN Hold Time to CCLK/MCLK	1	—	ns	
t_{DCB}	CCLK/MCLK to BUSY Delay Time	—	12	ns	
t_{CORD}	CCLK to Out for Read Data	—	12	ns	
t_{BSCH}	CCLK Minimum High Pulse	6	—	ns	
t_{BSCL}	CCLK Minimum Low Pulse	6	—	ns	
t_{BSCYC}	Byte Slave Cycle Time	30	—	ns	
f_{CCLK}	CCLK/MCLK Frequency	Without encryption	—	33	MHz
		With encryption	—	20	MHz
Master and Slave SPI					
t_{CFGX}	INITN High to MCLK Low	—	80	ns	
t_{CSSPI}	INITN High to CSSPIN Low	0.2	2	μ s	
t_{SOCDO}	MCLK Low to Output Valid	—	15	ns	
t_{CSPID}	CSSPIN[0:1] Low to First MCLK Edge Setup Time	0.3		μ s	
f_{CCLK}	CCLK Frequency	Without encryption	—	33	MHz
		With encryption	—	20	MHz
t_{SSCH}	CCLK Minimum High Pulse	5	—	ns	
t_{SSCL}	CCLK Minimum Low Pulse	5	—	ns	
t_{HLCH}	HOLDN Low Setup Time (Relative to CCLK)	5	—	ns	

LatticeECP3 sysCONFIG Port Timing Specifications (Continued)

Over Recommended Operating Conditions

Parameter	Description	Min.	Max.	Units
t_{CHHH}	HOLDN Low Hold Time (Relative to CCLK)	5	—	ns
Master and Slave SPI (Continued)				
t_{CHHL}	HOLDN High Hold Time (Relative to CCLK)	5	—	ns
t_{HHCH}	HOLDN High Setup Time (Relative to CCLK)	5	—	ns
t_{HLQZ}	HOLDN to Output High-Z	—	9	ns
t_{HHQX}	HOLDN to Output Low-Z	—	9	ns

Parameter	Min.	Max.	Units
Master Clock Frequency	Selected value - 15%	Selected value + 15%	MHz
Duty Cycle	40	60	%

Figure 3-16. sysCONFIG Parallel Port Read Cycle



Figure 3-17. sysCONFIG Parallel Port Write Cycle



1. In Master Parallel Mode the FPGA provides CCLK (MCLK). In Slave Parallel Mode the external device provides CCLK.

Figure 3-18. sysCONFIG Master Serial Port Timing

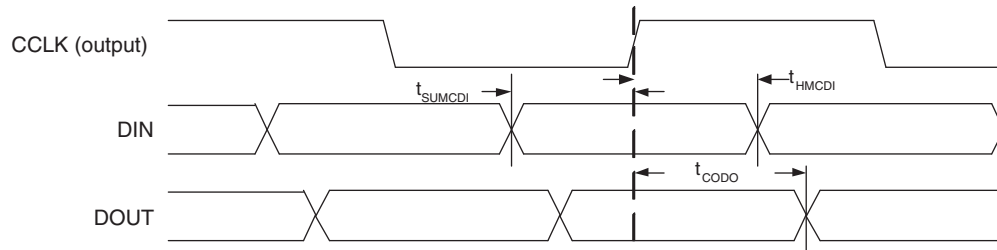

Figure 3-19. sysCONFIG Slave Serial Port Timing

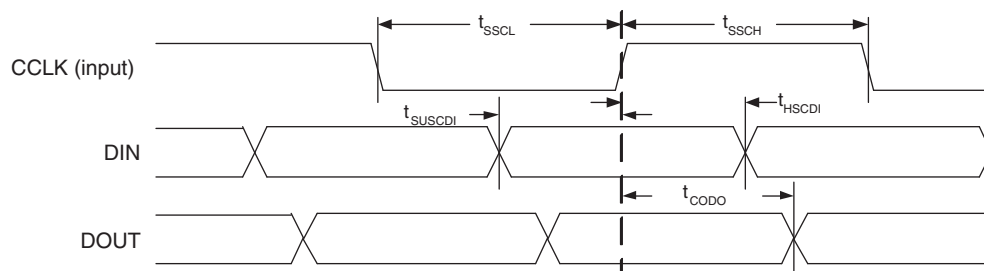

Figure 3-22. Configuration from PROGRAMN Timing



1. The CFG pins are normally static (hard wired)

Figure 3-23. Wake-Up Timing



Figure 3-24. Master SPI Configuration Waveforms



JTAG Port Timing Specifications

Over Recommended Operating Conditions

Symbol	Parameter	Min	Max	Units
f_{MAX}	TCK clock frequency	—	25	MHz
t_{BTCP}	TCK [BSCAN] clock pulse width	40	—	ns
t_{BTCPH}	TCK [BSCAN] clock pulse width high	20	—	ns
t_{BTCPL}	TCK [BSCAN] clock pulse width low	20	—	ns
t_{BTS}	TCK [BSCAN] setup time	10	—	ns
t_{BTH}	TCK [BSCAN] hold time	8	—	ns
t_{BTRF}	TCK [BSCAN] rise/fall time	50	—	mV/ns
t_{BTCO}	TAP controller falling edge of clock to valid output	—	10	ns
$t_{BTCODIS}$	TAP controller falling edge of clock to valid disable	—	10	ns
t_{BTCOEN}	TAP controller falling edge of clock to valid enable	—	10	ns
t_{BTCRS}	BSCAN test capture register setup time	8	—	ns
t_{BTCRH}	BSCAN test capture register hold time	25	—	ns
t_{BUTCO}	BSCAN test update register, falling edge of clock to valid output	—	25	ns
$t_{BTUODIS}$	BSCAN test update register, falling edge of clock to valid disable	—	25	ns
$t_{BTUPOEN}$	BSCAN test update register, falling edge of clock to valid enable	—	25	ns

Figure 3-25. JTAG Port Timing Waveforms



Switching Test Conditions

Figure 3-26 shows the output test load that is used for AC testing. The specific values for resistance, capacitance, voltage, and other test conditions are shown in Table 3-23.

Figure 3-26. Output Test Load, LVTTTL and LVCMOS Standards



*CL Includes Test Fixture and Probe Capacitance

Table 3-23. Test Fixture Required Components, Non-Terminated Interfaces

Test Condition	R ₁	R ₂	C _L	Timing Ref.	V _T
LVTTTL and other LVCMOS settings (L -> H, H -> L)	∞	∞	0pF	LVCMOS 3.3 = 1.5V	—
				LVCMOS 2.5 = V _{CCIO} /2	—
				LVCMOS 1.8 = V _{CCIO} /2	—
				LVCMOS 1.5 = V _{CCIO} /2	—
				LVCMOS 1.2 = V _{CCIO} /2	—
LVCMOS 2.5 I/O (Z -> H)	∞	1MΩ	0pF	V _{CCIO} /2	—
LVCMOS 2.5 I/O (Z -> L)	1MΩ	∞	0pF	V _{CCIO} /2	V _{CCIO}
LVCMOS 2.5 I/O (H -> Z)	∞	100	0pF	V _{OH} - 0.10	—
LVCMOS 2.5 I/O (L -> Z)	100	∞	0pF	V _{OL} + 0.10	V _{CCIO}

Note: Output test conditions for all other interfaces are determined by the respective standards.

sysI/O Differential Electrical Characteristics

Transition Reduced LVDS (TRLVDS DC Specification)

Over Recommended Operating Conditions

Symbol	Description	Min.	Nom.	Max.	Units
V_{CCO}	Driver supply voltage (+/- 5%)	3.14	3.3	3.47	V
V_{ID}	Input differential voltage	150		1200	mV
V_{ICM}	Input common mode voltage	3		3.265	V
V_{CCO}	Termination supply voltage	3.14	3.3	3.47	V
R_T	Termination resistance (off-chip)	45	50	55	Ohms

Note: LatticeECP3 only supports the TRLVDS receiver.



Mini LVDS

Over Recommended Operating Conditions

Parameter Symbol	Description	Min.	Typ.	Max.	Units
Z_0	Single-ended PCB trace impedance	30	50	75	ohms
R_T	Differential termination resistance	50	100	150	ohms
V_{OD}	Output voltage, differential, $ V_{OP} - V_{OM} $	300	—	600	mV
V_{OS}	Output voltage, common mode, $ V_{OP} + V_{OM} /2$	1	1.2	1.4	V
ΔV_{OD}	Change in V_{OD} , between H and L	—	—	50	mV
ΔV_{ID}	Change in V_{OS} , between H and L	—	—	50	mV
V_{THD}	Input voltage, differential, $ V_{INP} - V_{INM} $	200	—	600	mV
V_{CM}	Input voltage, common mode, $ V_{INP} + V_{INM} /2$	$0.3+(V_{THD}/2)$	—	$2.1-(V_{THD}/2)$	
T_R, T_F	Output rise and fall times, 20% to 80%	—	—	550	ps
T_{ODUTY}	Output clock duty cycle	40	—	60	%

Note: Data is for 6mA differential current drive. Other differential driver current options are available.

Point-to-Point LVDS (PPLVDS)**Over Recommended Operating Conditions**

Description	Min.	Typ.	Max.	Units
Output driver supply (+/- 5%)	3.14	3.3	3.47	V
	2.25	2.5	2.75	V
Input differential voltage	100		400	mV
Input common mode voltage	0.2		2.3	V
Output differential voltage	130		400	mV
Output common mode voltage	0.5	0.8	1.4	V

RSDS**Over Recommended Operating Conditions**

Parameter Symbol	Description	Min.	Typ.	Max.	Units
V_{OD}	Output voltage, differential, $R_T = 100$ ohms	100	200	600	mV
V_{OS}	Output voltage, common mode	0.5	1.2	1.5	V
I_{RSDS}	Differential driver output current	1	2	6	mA
V_{THD}	Input voltage differential	100	—	—	mV
V_{CM}	Input common mode voltage	0.3	—	1.5	V
T_R, T_F	Output rise and fall times, 20% to 80%	—	500	—	ps
T_{ODUTY}	Output clock duty cycle	35	50	65	%

Note: Data is for 2mA drive. Other differential driver current options are available.

Signal Descriptions

Signal Name	I/O	Description
General Purpose		
P[Edge] [Row/Column Number]_[A/B]	I/O	<p>[Edge] indicates the edge of the device on which the pad is located. Valid edge designations are L (Left), B (Bottom), R (Right), T (Top).</p> <p>[Row/Column Number] indicates the PFU row or the column of the device on which the PIC exists. When Edge is T (Top) or B (Bottom), only need to specify Column Number. When Edge is L (Left) or R (Right), only need to specify Row Number.</p> <p>[A/B] indicates the PIO within the PIC to which the pad is connected. Some of these user-programmable pins are shared with special function pins. These pins, when not used as special purpose pins, can be programmed as I/Os for user logic. During configuration the user-programmable I/Os are tri-stated with an internal pull-up resistor enabled. If any pin is not used (or not bonded to a package pin), it is also tri-stated with an internal pull-up resistor enabled after configuration.</p>
P[Edge][Row Number]E_[A/B/C/D]	I	These general purpose signals are input-only pins and are located near the PLLs.
GSRN	I	Global RESET signal (active low). Any I/O pin can be GSRN.
NC	—	No connect.
RESERVED	—	This pin is reserved and should not be connected to anything on the board.
GND	—	Ground. Dedicated pins.
V _{CC}	—	Power supply pins for core logic. Dedicated pins.
V _{CCAUX}	—	Auxiliary power supply pin. This dedicated pin powers all the differential and referenced input buffers.
V _{CCIOx}	—	Dedicated power supply pins for I/O bank x.
V _{CCA}	—	SERDES, transmit, receive, PLL and reference clock buffer power supply.
V _{CCPLL} _[LOC]	—	General purpose PLL supply pins where LOC=L (left) or R (right).
V _{REF1_x} , V _{REF2_x}	—	Reference supply pins for I/O bank x. Pre-determined pins in each bank are assigned as V _{REF} inputs. When not used, they may be used as I/O pins.
VTTx	—	Power supply for on-chip termination of I/Os (Required for DDR3 and LVDS at 1.25Gbps).
XRES ¹	—	10K ohm +/-1% resistor must be connected between this pad and ground.
PLL, DLL and Clock Functions		
[LOC][num]_GPLL[T, C]_IN_[index]	I	General Purpose PLL (GPLL) input pads: LUM, LLM, RUM, RLM, num = row from center, T = true and C = complement, index A,B,C...at each side.
[LOC][num]_GPLL[T, C]_FB_[index]	I	Optional feedback GPLL input pads: LUM, LLM, RUM, RLM, num = row from center, T = true and C = complement, index A,B,C...at each side.
[LOC]0_GDLLT_IN_[index]	I/O	General Purpose DLL (GDLL) input pads where LOC=RUM or LUM, T is True Complement, index is A or B.
[LOC]0_GDLLT_FB_[index]	I/O	Optional feedback GDLL input pads where LOC=RUM or LUM, T is True Complement, index is A or B.
PCLK[T, C][n:0]_[3:0]	I	Primary Clock pads, T = true and C = complement, n per side, indexed by bank and 0, 1, 2, 3 within bank.

© 2010 Lattice Semiconductor Corp. All Lattice trademarks, registered trademarks, patents, and disclaimers are as listed at www.latticesemi.com/legal. All other brand or product names are trademarks or registered trademarks of their respective holders. The specifications and information herein are subject to change without notice.

Signal Descriptions (Cont.)

Signal Name	I/O	Description
[LOC]DQS[num]	I/O	DQ input/output pads: T (top), R (right), B (bottom), L (left), DQS, num = ball function number.
[LOC]DQ[num]	I/O	DQ input/output pads: T (top), R (right), B (bottom), L (left), DQ, associated DQS number.
Test and Programming (Dedicated Pins)		
TMS	I	Test Mode Select input, used to control the 1149.1 state machine. Pull-up is enabled during configuration.
TCK	I	Test Clock input pin, used to clock the 1149.1 state machine. No pull-up enabled.
TDI	I	Test Data in pin. Used to load data into device using 1149.1 state machine. After power-up, this TAP port can be activated for configuration by sending appropriate command. (Note: once a configuration port is selected it is locked. Another configuration port cannot be selected until the power-up sequence). Pull-up is enabled during configuration.
TDO	O	Output pin. Test Data Out pin used to shift data out of a device using 1149.1.
VCCJ	—	Power supply pin for JTAG Test Access Port.
Configuration Pads (Used During sysCONFIG)		
CFG[2:0]	I	Mode pins used to specify configuration mode values latched on rising edge of INITN. During configuration, a pull-up is enabled. These are dedicated pins.
INITN	I/O	Open Drain pin. Indicates the FPGA is ready to be configured. During configuration, a pull-up is enabled. It is a dedicated pin.
PROGRAMN	I	Initiates configuration sequence when asserted low. This pin always has an active pull-up. It is a dedicated pin.
DONE	I/O	Open Drain pin. Indicates that the configuration sequence is complete, and the startup sequence is in progress. It is a dedicated pin.
CCLK	I	Input Configuration Clock for configuring an FPGA in Slave SPI, Serial, and CPU modes. It is a dedicated pin.
MCLK	I/O	Output Configuration Clock for configuring an FPGA in SPI, SPIm, and Master configuration modes.
BUSY/SISPI	O	Parallel configuration mode busy indicator. SPI/SPIm mode data output.
CSN/SN/OEN	I/O	Parallel configuration mode active-low chip select. Slave SPI chip select. Parallel burst Flash output enable.
CS1N/HOLDN/RDY	I	Parallel configuration mode active-low chip select. Slave SPI hold input.
WRITEN	I	Write enable for parallel configuration modes.
DOUT/CSN/CSSPI1N	O	Serial data output. Chip select output. SPI/SPIm mode chip select.
D[0]/SPIFASTN	I/O	sysCONFIG Port Data I/O for Parallel mode. Open drain during configuration. sysCONFIG Port Data I/O for SPI or SPIm. When using the SPI or SPIm mode, this pin should either be tied high or low, must not be left floating. Open drain during configuration.
D1	I/O	Parallel configuration I/O. Open drain during configuration.
D2	I/O	Parallel configuration I/O. Open drain during configuration.
D3/SI	I/O	Parallel configuration I/O. Slave SPI data input. Open drain during configuration.
D4/SO	I/O	Parallel configuration I/O. Slave SPI data output. Open drain during configuration.
D5	I/O	Parallel configuration I/O. Open drain during configuration.
D6/SPID1	I/O	Parallel configuration I/O. SPI/SPIm data input. Open drain during configuration.

Signal Descriptions (Cont.)

Signal Name	I/O	Description
D7/SPID0	I/O	Parallel configuration I/O. SPI/SPI _m data input. Open drain during configuration.
DI/CSSPI0N/CEN	I/O	Serial data input for slave serial mode. SPI/SPI _m mode chip select.
Dedicated SERDES Signals²		
PCS[Index]_HDINN _m	I	High-speed input, negative channel m
PCS[Index]_HDOUTN _m	O	High-speed output, negative channel m
PCS[Index]_REFCLKN	I	Negative Reference Clock Input
PCS[Index]_HDINP _m	I	High-speed input, positive channel m
PCS[Index]_HDOUTP _m	O	High-speed output, positive channel m
PCS[Index]_REFCLKP	I	Positive Reference Clock Input
PCS[Index]_VCCOB _m	—	Output buffer power supply, channel m (1.2V/1.5)
PCS[Index]_VCCIB _m	—	Input buffer power supply, channel m (1.2V/1.5V)

1. When placing switching I/Os around these critical pins that are designed to supply the device with the proper reference or supply voltage, care must be given.
2. m defines the associated channel in the quad.

PICs and DDR Data (DQ) Pins Associated with the DDR Strobe (DQS) Pin

PICs Associated with DQS Strobe	PIO Within PIC	DDR Strobe (DQS) and Data (DQ) Pins
For Left and Right Edges of the Device		
P[Edge] [n-3]	A	DQ
	B	DQ
P[Edge] [n-2]	A	DQ
	B	DQ
P[Edge] [n-1]	A	DQ
	B	DQ
P[Edge] [n]	A	[Edge]DQSn
	B	DQ
P[Edge] [n+1]	A	DQ
	B	DQ
P[Edge] [n+2]	A	DQ
	B	DQ
For Top Edge of the Device		
P[Edge] [n-3]	A	DQ
	B	DQ
P[Edge] [n-2]	A	DQ
	B	DQ
P[Edge] [n-1]	A	DQ
	B	DQ
P[Edge] [n]	A	[Edge]DQSn
	B	DQ
P[Edge] [n+1]	A	DQ
	B	DQ
P[Edge] [n+2]	A	DQ
	B	DQ

Note: "n" is a row PIC number.

Pin Information Summary

Pin Information Summary		ECP3-17EA		ECP3-35EA			ECP3-70E/EA		
Pin Type		256 ftBGA	484 fpBGA	256 ftBGA	484 fpBGA	672 fpBGA	484 fpBGA	672 fpBGA	1156 fpBGA
General Purpose Inputs/Outputs per Bank	Bank 0	26	36	26	42	48	42	60	86
	Bank 1	14	24	14	36	36	36	48	78
	Bank 2	6	12	6	24	24	24	34	36
	Bank 3	18	44	16	54	59	54	59	86
	Bank 6	20	44	18	63	61	63	67	86
	Bank 7	19	32	19	36	42	36	48	54
	Bank 8	24	24	24	24	24	24	24	24
General Purpose Inputs per Bank	Bank 0	0	0	0	0	0	0	0	0
	Bank 1	0	0	0	0	0	0	0	0
	Bank 2	2	2	2	4	4	4	8	8
	Bank 3	0	0	2	4	4	4	12	12
	Bank 6	0	0	2	4	4	4	12	12
	Bank 7	4	4	4	4	4	4	8	8
	Bank 8	0	0	0	0	0	0	0	0
General Purpose Outputs per Bank	Bank 0	0	0	0	0	0	0	0	0
	Bank 1	0	0	0	0	0	0	0	0
	Bank 2	0	0	0	0	0	0	0	0
	Bank 3	0	0	0	0	0	0	0	0
	Bank 6	0	0	0	0	0	0	0	0
	Bank 7	0	0	0	0	0	0	0	0
	Bank 8	0	0	0	0	0	0	0	0
Total Single-Ended User I/O		133	222	133	295	310	295	380	490
VCC		6	16	6	16	32	16	32	32
VCCAUX		4	8	4	8	12	8	12	16
VTT		4	4	4	4	4	4	4	8
VCCA		4	4	4	4	8	4	8	16
VCCPLL		2	4	2	4	4	4	4	4
VCCIO	Bank 0	2	2	2	2	4	2	4	4
	Bank 1	2	2	2	2	4	2	4	4
	Bank 2	2	2	2	2	4	2	4	4
	Bank 3	2	2	2	2	4	2	4	4
	Bank 6	2	2	2	2	4	2	4	4
	Bank 7	2	2	2	2	4	2	4	4
	Bank 8	2	2	2	2	2	2	2	2
VCCJ		1	1	1	1	1	1	1	1
TAP		4	4	4	4	4	4	4	4
GND, GNDIO		50	98	50	98	139	98	139	233
NC		0	73	0	0	96	0	0	238
Reserved ¹		0	2	0	2	2	2	2	2
SERDES		26	26	26	26	26	26	52	78
Miscellaneous Pins		8	8	8	8	8	8	8	8
Total Bonded Pins		256	484	256	484	672	484	672	1156

Pin Information Summary (Cont.)

Pin Information Summary		ECP3-17EA		ECP3-35EA		
Pin Type		256 ftBGA	484 fpBGA	256 ftBGA	484 fpBGA	672 fpBGA
Emulated Differential I/O per Bank	Bank 0	13	18	13	21	24
	Bank 1	7	12	7	18	18
	Bank 2	2	4	1	8	8
	Bank 3	4	13	5	20	19
	Bank 6	5	13	6	22	20
	Bank 7	6	10	6	11	13
	Bank 8	12	12	12	12	12
Highspeed Differential I/O per Bank	Bank 0	0	0	0	0	0
	Bank 1	0	0	0	0	0
	Bank 2	2	3	3	6	6
	Bank 3	5	9	4	9	12
	Bank 6	5	9	4	11	12
	Bank 7	5	8	5	9	10
	Bank 8	0	0	0	0	0
Total Single Ended/ Total Differential I/O per Bank	Bank 0	26/13	36/18	26/13	42/21	48/24
	Bank 1	14/7	24/12	14/7	36/18	36/18
	Bank 2	8/4	14/7	8/4	28/14	28/14
	Bank 3	18/9	44/22	18/9	58/29	63/31
	Bank 6	20/10	44/22	20/10	67/33	65/32
	Bank 7	23/11	36/18	23/11	40/20	46/23
	Bank 8	24/12	24/12	24/12	24/12	24/12
DDR Groups Bonded per Bank	Bank 0	2	3	2	3	4
	Bank 1	1	2	1	3	3
	Bank 2	0	1	0	2	2
	Bank 3	1	3	1	3	4
	Bank 6	1	3	1	4	4
	Bank 7	1	2	1	3	3
	Configuration Bank 8	0	0	0	0	0
SERDES Quads		1	1	1	1	1

1. These pins must remain floating on the board.

Pin Information Summary (Cont.)

Pin Information Summary		ECP3-70E			ECP3-70EA		
Pin Type		484 fpBGA	672 fpBGA	1156 fpBGA	484 fpBGA	672 fpBGA	1156 fpBGA
Emulated Differential I/O per Bank	Bank 0	21	30	43	21	30	43
	Bank 1	18	24	39	18	24	39
	Bank 2	10	15	16	8	12	13
	Bank 3	23	27	39	20	23	33
	Bank 6	26	30	39	22	25	33
	Bank 7	14	20	22	11	16	18
	Bank 8	12	12	12	12	12	12
High-Speed Differential I/O per Bank	Bank 0	0	0	0	0	0	0
	Bank 1	0	0	0	0	0	0
	Bank 2	4	6	6	6	9	9
	Bank 3	6	8	10	9	12	16
	Bank 6	7	9	10	11	14	16
	Bank 7	6	8	9	9	12	13
	Bank 8	0	0	0	0	0	0
Total Single-Ended/ Total Differential I/O per Bank	Bank 0	42/21	60/30	86/43	42/21	60/30	86/43
	Bank 1	36/18	48/24	78/39	36/18	48/24	78/39
	Bank 2	28/14	42/21	44/22	28/14	42/21	44/22
	Bank 3	58/29	71/35	98/49	58/29	71/35	98/49
	Bank 6	67/33	79/38	98/49	67/33	78/39	98/49
	Bank 7	40/20	56/28	62/31	40/20	56/28	62/31
	Bank 8	24/12	24/12	24/12	24/12	24/12	24/12
DDR Groups Bonded per Bank	Bank 0	3	5	7	3	5	7
	Bank 1	3	4	7	3	4	7
	Bank 2	2	3	3	2	3	3
	Bank 3	3	4	5	3	4	5
	Bank 6	4	4	5	4	4	5
	Bank 7	3	4	4	3	4	4
	Configuration Bank 8	0	0	0	0	0	0
SERDES Quads	1	2	3	1	2	3	

Pin Information Summary (Cont.)

Pin Information Summary		ECP3-95E/EA			ECP3-150EA	
Pin Type		484 fpBGA	672 fpBGA	1156 fpBGA	672 fpBGA	1156 fpBGA
General Purpose Inputs/Outputs per bank	Bank 0	42	60	86	60	94
	Bank 1	36	48	78	48	86
	Bank 2	24	34	36	34	58
	Bank 3	54	59	86	59	104
	Bank 6	63	67	86	67	104
	Bank 7	36	48	54	48	76
	Bank 8	24	24	24	24	24
General Purpose Inputs per Bank	Bank 0	0	0	0	0	0
	Bank 1	0	0	0	0	0
	Bank 2	4	8	8	8	8
	Bank 3	4	12	12	12	12
	Bank 6	4	12	12	12	12
	Bank 7	4	8	8	8	8
	Bank 8	0	0	0	0	0
General Purpose Outputs per Bank	Bank 0	0	0	0	0	0
	Bank 1	0	0	0	0	0
	Bank 2	0	0	0	0	0
	Bank 3	0	0	0	0	0
	Bank 6	0	0	0	0	0
	Bank 7	0	0	0	0	0
	Bank 8	0	0	0	0	0
Total Single-Ended User I/O		295	380	490	380	586
VCC		16	32	32	32	32
VCCAUX		8	12	16	12	16
VTT		4	4	8	4	8
VCCA		4	8	16	8	16
VCCPLL		4	4	4	4	4
VCCIO	Bank 0	2	4	4	4	4
	Bank 1	2	4	4	4	4
	Bank 2	2	4	4	4	4
	Bank 3	2	4	4	4	4
	Bank 6	2	4	4	4	4
	Bank 7	2	4	4	4	4
	Bank 8	2	2	2	2	2
VCCJ		1	1	1	1	1
TAP		4	4	4	4	4
GND, GNDIO		98	139	233	139	233
NC		0	0	238	0	116
Reserved ¹		2	2	2	2	2
SERDES		26	52	78	52	104
Miscellaneous Pins		8	8	8	8	8
Total Bonded Pins		484	672	1156	672	1156

Pin Information Summary (Cont.)

Pin Information Summary		ECP3-95E			ECP3-95EA			ECP3-150EA	
Pin Type		484 fpBGA	672 fpBGA	1156 fpBGA	484 fpBGA	672 fpBGA	1156 fpBGA	672 fpBGA	1156 fpBGA
Emulated Differential I/O per Bank	Bank 0	21	30	43	21	30	43	30	47
	Bank 1	18	24	39	18	24	39	24	43
	Bank 2	10	15	16	8	12	13	12	18
	Bank 3	23	27	39	20	23	33	23	37
	Bank 6	26	30	39	22	25	33	25	37
	Bank 7	14	20	22	11	16	18	16	24
	Bank 8	12	12	12	12	12	12	12	12
Highspeed Differential I/O per Bank	Bank 0	0	0	0	0	0	0	0	0
	Bank 1	0	0	0	0	0	0	0	0
	Bank 2	4	6	6	6	9	9	9	15
	Bank 3	6	8	10	9	12	16	12	21
	Bank 6	7	9	10	11	14	16	14	21
	Bank 7	6	8	9	9	12	13	12	18
	Bank 8	0	0	0	0	0	0	0	0
Total Single Ended/ Total Differential I/O per Bank	Bank 0	42/21	60/30	86/43	42/21	60/30	86/43	60/30	94/47
	Bank 1	36/18	48/24	78/39	36/18	48/24	78/39	48/24	86/43
	Bank 2	28/14	42/21	44/22	28/14	42/21	44/22	42/21	66/33
	Bank 3	58/29	71/35	98/49	58/29	71/35	98/49	71/35	116/58
	Bank 6	67/33	78/39	98/49	67/33	78/39	98/49	78/39	116/58
	Bank 7	40/20	56/28	62/31	40/20	56/28	62/31	56/28	84/42
	Bank 8	24/12	24/12	24/12	24/12	24/12	24/12	24/12	24/12
DDR Groups Bonded per Bank	Bank 0	3	5	7	3	5	7	5	7
	Bank 1	3	4	7	3	4	7	4	7
	Bank 2	2	3	3	2	3	3	3	4
	Bank 3	3	4	5	3	4	5	4	7
	Bank 6	4	4	5	4	4	5	4	7
	Bank 7	3	4	4	3	4	4	4	6
	Configuration Bank8	0	0	0	0	0	0	0	0
SERDES Quads	1	2	3	1	2	3	2	4	

1. These pins must remain floating on the board.

Logic Signal Connections

Package pinout information can be found under “Data Sheets” on the LatticeECP3 product pages on the Lattice website at www.latticesemi.com/products/fpga/ecp3 and in the Lattice ispLEVER Design Planner software. To create pinout information from within Design Planner, select **View -> Package View**. Then select **Select File -> Export** and choose a type of output file. See Design Planner help for more information.

Thermal Management

Thermal management is recommended as part of any sound FPGA design methodology. To assess the thermal characteristics of a system, Lattice specifies a maximum allowable junction temperature in all device data sheets. Designers must complete a thermal analysis of their specific design to ensure that the device and package do not exceed the junction temperature limits. Refer to the Thermal Management document to find the device/package specific thermal values.

For Further Information

For further information regarding Thermal Management, refer to the following:

- [Thermal Management](#) document
- TN1181, [Power Consumption and Management for LatticeECP3 Devices](#)
- Power Calculator tool included with the Lattice ispLEVER design tool, or as a standalone download from www.latticesemi.com/software

LatticeECP3 Part Number Description



Ordering Information

LatticeECP3 devices have top-side markings, for commercial and industrial grades, as shown below:



LatticeECP3 Devices, Lead-Free Packaging

The following devices may have associated errata. Specific devices with associated errata will be notated with a footnote.

Commercial

Part Number	Voltage	Grade	Package	Pins	Temp.	LUTs (K)
LFE3-17EA-6FTN256C	1.2V	-6	Lead-Free ftBGA	256	COM	17
LFE3-17EA-7FTN256C	1.2V	-7	Lead-Free ftBGA	256	COM	17
LFE3-17EA-8FTN256C	1.2V	-8	Lead-Free ftBGA	256	COM	17
LFE3-17EA-6FN484C	1.2V	-6	Lead-Free fpBGA	484	COM	17
LFE3-17EA-7FN484C	1.2V	-7	Lead-Free fpBGA	484	COM	17
LFE3-17EA-8FN484C	1.2V	-8	Lead-Free fpBGA	484	COM	17

Part Number	Voltage	Grade	Package	Pins	Temp.	LUTs (K)
LFE3-35EA-6FTN256C	1.2V	-6	Lead-Free ftBGA	256	COM	33
LFE3-35EA-7FTN256C	1.2V	-7	Lead-Free ftBGA	256	COM	33
LFE3-35EA-8FTN256C	1.2V	-8	Lead-Free ftBGA	256	COM	33
LFE3-35EA-6FN484C	1.2V	-6	Lead-Free fpBGA	484	COM	33
LFE3-35EA-7FN484C	1.2V	-7	Lead-Free fpBGA	484	COM	33
LFE3-35EA-8FN484C	1.2V	-8	Lead-Free fpBGA	484	COM	33
LFE3-35EA-6FN672C	1.2V	-6	Lead-Free fpBGA	672	COM	33
LFE3-35EA-7FN672C	1.2V	-7	Lead-Free fpBGA	672	COM	33
LFE3-35EA-8FN672C	1.2V	-8	Lead-Free fpBGA	672	COM	33

Part Number	Voltage	Grade	Package	Pins	Temp.	LUTs (K)
LFE3-70EA-6FN484C	1.2V	-6	Lead-Free fpBGA	484	COM	67
LFE3-70EA-7FN484C	1.2V	-7	Lead-Free fpBGA	484	COM	67
LFE3-70EA-8FN484C	1.2V	-8	Lead-Free fpBGA	484	COM	67
LFE3-70EA-6FN672C	1.2V	-6	Lead-Free fpBGA	672	COM	67
LFE3-70EA-7FN672C	1.2V	-7	Lead-Free fpBGA	672	COM	67
LFE3-70EA-8FN672C	1.2V	-8	Lead-Free fpBGA	672	COM	67
LFE3-70EA-6FN1156C	1.2V	-6	Lead-Free fpBGA	1156	COM	67
LFE3-70EA-7FN1156C	1.2V	-7	Lead-Free fpBGA	1156	COM	67
LFE3-70EA-8FN1156C	1.2V	-8	Lead-Free fpBGA	1156	COM	67

Part Number	Voltage	Grade	Package	Pins	Temp.	LUTs (K)
LFE3-70E-6FN484C ¹	1.2V	-6	Lead-Free fpBGA	484	COM	67
LFE3-70E-7FN484C ¹	1.2V	-7	Lead-Free fpBGA	484	COM	67
LFE3-70E-8FN484C ¹	1.2V	-8	Lead-Free fpBGA	484	COM	67
LFE3-70E-6FN672C ¹	1.2V	-6	Lead-Free fpBGA	672	COM	67
LFE3-70E-7FN672C ¹	1.2V	-7	Lead-Free fpBGA	672	COM	67
LFE3-70E-8FN672C ¹	1.2V	-8	Lead-Free fpBGA	672	COM	67
LFE3-70E-6FN1156C ¹	1.2V	-6	Lead-Free fpBGA	1156	COM	67
LFE3-70E-7FN1156C ¹	1.2V	-7	Lead-Free fpBGA	1156	COM	67
LFE3-70E-8FN1156C ¹	1.2V	-8	Lead-Free fpBGA	1156	COM	67

1. This device has associated errata. View www.latticesemi.com/documents/ds1021.zip for a description of the errata.

Part Number	Voltage	Grade	Package	Pins	Temp.	LUTs (K)
LFE3-95EA-6FN484C	1.2V	-6	Lead-Free fpBGA	484	COM	92
LFE3-95EA-7FN484C	1.2V	-7	Lead-Free fpBGA	484	COM	92
LFE3-95EA-8FN484C	1.2V	-8	Lead-Free fpBGA	484	COM	92
LFE3-95EA-6FN672C	1.2V	-6	Lead-Free fpBGA	672	COM	92
LFE3-95EA-7FN672C	1.2V	-7	Lead-Free fpBGA	672	COM	92
LFE3-95EA-8FN672C	1.2V	-8	Lead-Free fpBGA	672	COM	92
LFE3-95EA-6FN1156C	1.2V	-6	Lead-Free fpBGA	1156	COM	92
LFE3-95EA-7FN1156C	1.2V	-7	Lead-Free fpBGA	1156	COM	92
LFE3-95EA-8FN1156C	1.2V	-8	Lead-Free fpBGA	1156	COM	92

Part Number	Voltage	Grade	Package	Pins	Temp.	LUTs (K)
LFE3-95E-6FN484C ¹	1.2V	-6	Lead-Free fpBGA	484	COM	92
LFE3-95E-7FN484C ¹	1.2V	-7	Lead-Free fpBGA	484	COM	92
LFE3-95E-8FN484C ¹	1.2V	-8	Lead-Free fpBGA	484	COM	92
LFE3-95E-6FN672C ¹	1.2V	-6	Lead-Free fpBGA	672	COM	92
LFE3-95E-7FN672C ¹	1.2V	-7	Lead-Free fpBGA	672	COM	92
LFE3-95E-8FN672C ¹	1.2V	-8	Lead-Free fpBGA	672	COM	92
LFE3-95E-6FN1156C ¹	1.2V	-6	Lead-Free fpBGA	1156	COM	92
LFE3-95E-7FN1156C ¹	1.2V	-7	Lead-Free fpBGA	1156	COM	92
LFE3-95E-8FN1156C ¹	1.2V	-8	Lead-Free fpBGA	1156	COM	92

1. This device has associated errata. View www.latticesemi.com/documents/ds1021.zip for a description of the errata.

Part Number	Voltage	Grade	Package	Pins	Temp.	LUTs (K)
LFE3-150EA-6FN672C	1.2V	-6	Lead-Free fpBGA	672	COM	149
LFE3-150EA-7FN672C	1.2V	-7	Lead-Free fpBGA	672	COM	149
LFE3-150EA-8FN672C	1.2V	-8	Lead-Free fpBGA	672	COM	149
LFE3-150EA-6FN1156C	1.2V	-6	Lead-Free fpBGA	1156	COM	149
LFE3-150EA-7FN1156C	1.2V	-7	Lead-Free fpBGA	1156	COM	149
LFE3-150EA-8FN1156C	1.2V	-8	Lead-Free fpBGA	1156	COM	149

Part Number	Voltage	Grade	Package	Pins	Temp.	LUTs (K)
LFE3-150EA-6FN672CTW*	1.2V	-6	Lead-Free fpBGA	672	COM	149
LFE3-150EA-7FN672CTW*	1.2V	-7	Lead-Free fpBGA	672	COM	149
LFE3-150EA-8FN672CTW*	1.2V	-8	Lead-Free fpBGA	672	COM	149
LFE3-150EA-6FN1156CTW*	1.2V	-6	Lead-Free fpBGA	1156	COM	149
LFE3-150EA-7FN1156CTW*	1.2V	-7	Lead-Free fpBGA	1156	COM	149
LFE3-150EA-8FN1156CTW*	1.2V	-8	Lead-Free fpBGA	1156	COM	149

*Note: Specifications for the LFE3-150EA-*spFNpkg*CTW and LFE3-150EA-*spFNpkg*ITW devices, (where *sp* is the speed and *pkg* is the package), are the same as the LFE3-150EA-*spFNpkg*C and LFE3-150EA-*spFNpkg*I devices respectively, except as specified below.

- The CTC (Clock Tolerance Circuit) inside the SERDES hard PCS in the TW device is not functional but it can be bypassed and implemented in soft IP.
- The SERDES XRES pin on the TW device passes CDM testing at 250V.

Industrial

The following devices may have associated errata. Specific devices with associated errata will be notated with a footnote.

Part Number	Voltage	Grade	Package	Pins	Temp.	LUTs (K)
LFE3-17EA-6FTN256I	1.2V	-6	Lead-Free ftBGA	256	IND	17
LFE3-17EA-7FTN256I	1.2V	-7	Lead-Free ftBGA	256	IND	17
LFE3-17EA-8FTN256I	1.2V	-8	Lead-Free ftBGA	256	IND	17
LFE3-17EA-6FN484I	1.2V	-6	Lead-Free fpBGA	484	IND	17
LFE3-17EA-7FN484I	1.2V	-7	Lead-Free fpBGA	484	IND	17
LFE3-17EA-8FN484I	1.2V	-8	Lead-Free fpBGA	484	IND	17

Part Number	Voltage	Grade	Package	Pins	Temp.	LUTs (K)
LFE3-35EA-6FTN256I	1.2V	-6	Lead-Free ftBGA	256	IND	33
LFE3-35EA-7FTN256I	1.2V	-7	Lead-Free ftBGA	256	IND	33
LFE3-35EA-8FTN256I	1.2V	-8	Lead-Free ftBGA	256	IND	33
LFE3-35EA-6FN484I	1.2V	-6	Lead-Free fpBGA	484	IND	33
LFE3-35EA-7FN484I	1.2V	-7	Lead-Free fpBGA	484	IND	33
LFE3-35EA-8FN484I	1.2V	-8	Lead-Free fpBGA	484	IND	33
LFE3-35EA-6FN672I	1.2V	-6	Lead-Free fpBGA	672	IND	33
LFE3-35EA-7FN672I	1.2V	-7	Lead-Free fpBGA	672	IND	33
LFE3-35EA-8FN672I	1.2V	-7	Lead-Free fpBGA	672	IND	33

Part Number	Voltage	Grade	Package	Pins	Temp.	LUTs (K)
LFE3-70EA-6FN484I	1.2V	-6	Lead-Free fpBGA	484	IND	67
LFE3-70EA-7FN484I	1.2V	-7	Lead-Free fpBGA	484	IND	67
LFE3-70EA-8FN484I	1.2V	-8	Lead-Free fpBGA	484	IND	67
LFE3-70EA-6FN672I	1.2V	-6	Lead-Free fpBGA	672	IND	67
LFE3-70EA-7FN672I	1.2V	-7	Lead-Free fpBGA	672	IND	67
LFE3-70EA-8FN672I	1.2V	-8	Lead-Free fpBGA	672	IND	67
LFE3-70EA-6FN1156I	1.2V	-6	Lead-Free fpBGA	1156	IND	67
LFE3-70EA-7FN1156I	1.2V	-7	Lead-Free fpBGA	1156	IND	67
LFE3-70EA-8FN1156I	1.2V	-8	Lead-Free fpBGA	1156	IND	67

Part Number	Voltage	Grade	Package	Pins	Temp.	LUTs (K)
LFE3-70E-6FN484I ¹	1.2V	-6	Lead-Free fpBGA	484	IND	67
LFE3-70E-7FN484I ¹	1.2V	-7	Lead-Free fpBGA	484	IND	67
LFE3-70E-8FN484I ¹	1.2V	-8	Lead-Free fpBGA	484	IND	67
LFE3-70E-6FN672I ¹	1.2V	-6	Lead-Free fpBGA	672	IND	67
LFE3-70E-7FN672I ¹	1.2V	-7	Lead-Free fpBGA	672	IND	67
LFE3-70E-8FN672I ¹	1.2V	-8	Lead-Free fpBGA	672	IND	67
LFE3-70E-6FN1156I ¹	1.2V	-6	Lead-Free fpBGA	1156	IND	67
LFE3-70E-7FN1156I ¹	1.2V	-7	Lead-Free fpBGA	1156	IND	67
LFE3-70E-8FN1156I ¹	1.2V	-8	Lead-Free fpBGA	1156	IND	67

1. This device has associated errata. View www.latticesemi.com/documents/ds1021.zip for a description of the errata.

Part Number	Voltage	Grade	Package	Pins	Temp.	LUTs (K)
LFE3-95EA-6FN484I	1.2V	-6	Lead-Free fpBGA	484	IND	92
LFE3-95EA-7FN484I	1.2V	-7	Lead-Free fpBGA	484	IND	92
LFE3-95EA-8FN484I	1.2V	-8	Lead-Free fpBGA	484	IND	92
LFE3-95EA-6FN672I	1.2V	-6	Lead-Free fpBGA	672	IND	92
LFE3-95EA-7FN672I	1.2V	-7	Lead-Free fpBGA	672	IND	92
LFE3-95EA-8FN672I	1.2V	-8	Lead-Free fpBGA	672	IND	92
LFE3-95EA-6FN1156I	1.2V	-6	Lead-Free fpBGA	1156	IND	92
LFE3-95EA-7FN1156I	1.2V	-7	Lead-Free fpBGA	1156	IND	92
LFE3-95EA-8FN1156I	1.2V	-8	Lead-Free fpBGA	1156	IND	92

Part Number	Voltage	Grade	Package	Pins	Temp.	LUTs (K)
LFE3-95E-6FN484I ¹	1.2V	-6	Lead-Free fpBGA	484	IND	92
LFE3-95E-7FN484I ¹	1.2V	-7	Lead-Free fpBGA	484	IND	92
LFE3-95E-8FN484I ¹	1.2V	-8	Lead-Free fpBGA	484	IND	92
LFE3-95E-6FN672I ¹	1.2V	-6	Lead-Free fpBGA	672	IND	92
LFE3-95E-7FN672I ¹	1.2V	-7	Lead-Free fpBGA	672	IND	92
LFE3-95E-8FN672I ¹	1.2V	-8	Lead-Free fpBGA	672	IND	92
LFE3-95E-6FN1156I ¹	1.2V	-6	Lead-Free fpBGA	1156	IND	92
LFE3-95E-7FN1156I ¹	1.2V	-7	Lead-Free fpBGA	1156	IND	92
LFE3-95E-8FN1156I ¹	1.2V	-8	Lead-Free fpBGA	1156	IND	92

1. This device has associated errata. View www.latticesemi.com/documents/ds1021.zip for a description of the errata.

Part Number	Voltage	Grade	Package	Pins	Temp.	LUTs (K)
LFE3-150EA-6FN672I	1.2V	-6	Lead-Free fpBGA	672	IND	149
LFE3-150EA-7FN672I	1.2V	-7	Lead-Free fpBGA	672	IND	149
LFE3-150EA-8FN672I	1.2V	-8	Lead-Free fpBGA	672	IND	149
LFE3-150EA-6FN1156I	1.2V	-6	Lead-Free fpBGA	1156	IND	149
LFE3-150EA-7FN1156I	1.2V	-7	Lead-Free fpBGA	1156	IND	149
LFE3-150EA-8FN1156I	1.2V	-8	Lead-Free fpBGA	1156	IND	149

Part Number	Voltage	Grade	Package	Pins	Temp.	LUTs (K)
LFE3-150EA-6FN672ITW*	1.2V	-6	Lead-Free fpBGA	672	IND	149
LFE3-150EA-7FN672ITW*	1.2V	-7	Lead-Free fpBGA	672	IND	149
LFE3-150EA-8FN672ITW*	1.2V	-8	Lead-Free fpBGA	672	IND	149
LFE3-150EA-6FN1156ITW*	1.2V	-6	Lead-Free fpBGA	1156	IND	149
LFE3-150EA-7FN1156ITW*	1.2V	-7	Lead-Free fpBGA	1156	IND	149
LFE3-150EA-8FN1156ITW*	1.2V	-8	Lead-Free fpBGA	1156	IND	149

*Note: Specifications for the LFE3-150EA-*spFNpkg*CTW and LFE3-150EA-*spFNpkg*ITW devices, (where *sp* is the speed and *pkg* is the package), are the same as the LFE3-150EA-*spFNpkg*C and LFE3-150EA-*spFNpkg*I devices respectively, except as specified below.

- The CTC (Clock Tolerance Circuit) inside the SERDES hard PCS in the TW device is not functional but it can be bypassed and implemented in soft IP.
- The SERDES XRES pin on the TW device passes CDM testing at 250V.

For Further Information

A variety of technical notes for the LatticeECP3 family are available on the Lattice website at www.latticesemi.com.

- TN1169, [LatticeECP3 sysCONFIG Usage Guide](#)
- TN1176, [LatticeECP3 SERDES/PCS Usage Guide](#)
- TN1177, [LatticeECP3 sysIO Usage Guide](#)
- TN1178, [LatticeECP3 sysCLOCK PLL/DLL Design and Usage Guide](#)
- TN1179, [LatticeECP3 Memory Usage Guide](#)
- TN1180, [LatticeECP3 High-Speed I/O Interface](#)
- TN1181, [Power Consumption and Management for LatticeECP3 Devices](#)
- TN1182, [LatticeECP3 sysDSP Usage Guide](#)
- TN1184, [LatticeECP3 Soft Error Detection \(SED\) Usage Guide](#)
- TN1189, [LatticeECP3 Hardware Checklist](#)

For further information on interface standards refer to the following websites:

- JEDEC Standards (LVTTTL, LVCMOS, SSTL, HSTL): www.jedec.org
- PCI: www.pcisig.com

Date	Version	Section	Change Summary	
February 2009	01.0	—	Initial release.	
May 2009	01.1	All	Removed references to Parallel burst mode Flash.	
		Introduction	Features - Changed 250 Mbps to 230 Mbps in Embedded SERDES bulleted section and added a footnote to indicate 230 Mbps applies to 8b10b and 10b12b applications.	
			Updated data for ECP3-17 in LatticeECP3 Family Selection Guide table.	
			Changed embedded memory from 552 to 700 Kbits in LatticeECP3 Family Selection Guide table.	
		Architecture	Updated description for CLKFB in General Purpose PLL Diagram.	
			Corrected Primary Clock Sources text section.	
			Corrected Secondary Clock/Control Sources text section.	
			Corrected Secondary Clock Regions table.	
			Corrected note below Detailed sysDSP Slice Diagram.	
			Corrected Clock, Clock Enable, and Reset Resources text section.	
			Corrected ECP3-17 EBR number in Embedded SRAM in the LatticeECP3 Family table.	
			Added On-Chip Termination Options for Input Modes table.	
			Updated Available SERDES Quads per LatticeECP3 Devices table.	
			Updated Simplified Channel Block Diagram for SERDES/PCS Block diagram.	
			Updated Device Configuration text section.	
			Corrected software default value of MCLK to be 2.5 MHz.	
			DC and Switching Characteristics	Updated VCCOB Min/Max data in Recommended Operating Conditions table.
				Corrected footnote 2 in sysIO Recommended Operating Conditions table.
		Added added footnote 7 for t_{SKEW_PRIB} to External Switching Characteristics table.		
		Added 2-to-1 Gearing text section and table.		
		Updated External Reference Clock Specification (refclkp/refclkn) table.		
		LatticeECP3 sysCONFIG Port Timing Specifications - updated t_{DINIT} information.		
		Added sysCONFIG Port Timing waveform.		
		Serial Input Data Specifications table, delete Typ data for $V_{RX-DIFF-S}$.		
		Added footnote 4 to sysCLOCK PLL Timing table for t_{PFD} .		
		Added SERDES/PCS Block Latency Breakdown table.		
		External Reference Clock Specifications table, added footnote 4, add symbol name vREF-IN-DIFF.		
Added SERDES External Reference Clock Waveforms.				
Updated Serial Output Timing and Levels table.				
Pin-to-pin performance table, changed "typically 3% slower" to "typically slower".				

Date	Version	Section	Change Summary	
May 2009 (cont.)	01.1 (cont.)	DC and Switching Characteristics (cont.)	Updated timing information	
			Updated SERDES minimum frequency.	
			Added data to the following tables: External Switching Characteristics, Internal Switching Characteristics, Family Timing Adders, Maximum I/O Buffer Speed, DLL Timing, High Speed Data Transmitter, Channel Output Jitter, Typical Building Block Function Performance, Register-to-Register Performance, and Power Supply Requirements.	
			Updated Serial Input Data Specifications table.	
		Pinout Information	Updated Transmit table, Serial Rapid I/O Type 2 Electrical and Timing Characteristics section.	
			Updated Signal Description tables. Updated Pin Information Summary tables and added footnote 1.	
July 2009	01.2	Multiple	Changed references of “multi-boot” to “dual-boot” throughout the data sheet.	
			Architecture	Updated On-Chip Programmable Termination bullets.
				Updated On-Chip Termination Options for Input Modes table. Updated On-Chip Termination figure.
		DC and Switching Characteristics	Changed min/max data for FREF_PPM and added footnote 4 in SERDES External Reference Clock Specification table.	
			Updated SERDES minimum frequency.	
		Pinout Information	Corrected MCLK to be I/O and CCLK to be I in Signal Descriptions table	
		August 2009	01.3	DC and Switching Characteristics
September 2009	01.4	Architecture	Corrected link in sysMEM Memory Block section.	
			Updated information for On-Chip Programmable Termination and modified corresponding figure.	
			Added footnote 2 to On-Chip Programmable Termination Options for Input Modes table.	
			Corrected Per Quadrant Primary Clock Selection figure.	
		DC and Switching Characteristics	Modified -8 Timing data for 1024x18 True-Dual Port RAM (Read-Before-Write, EBR Output Registers)	
			Added ESD Performance table.	
			LatticeECP3 External Switching Characteristics table - updated data for $t_{DIBGDDR}$, t_{W_PRI} , t_{W_EDGE} and $t_{SKEW_EDGE_DQS}$.	
			LatticeECP3 Internal Switching Characteristics table - updated data for t_{COO_PIO} and added footnote #4.	
			sysCLOCK PLL Timing table - updated data for f_{OUT} .	
			External Reference Clock Specification (refclkp/refclkn) table - updated data for $V_{REF-IN-SE}$ and $V_{REF-IN-DIFF}$.	
			LatticeECP3 sysCONFIG Port Timing Specifications table - updated data for t_{MWC} .	
			Added TRLVDS DC Specification table and diagram.	
			Updated Mini LVDS table.	
			November 2009	01.5
Added SONET/SDH to Embedded SERDES protocols.				
Architecture	Updated Figure 2-4, General Purpose PLL Diagram.			
	Updated SONET/SDH to SERDES and PCS protocols.			

Date	Version	Section	Change Summary
November 2009 (cont.)	01.5 (cont.)	Architecture (cont.)	Updated Table 2-13, SERDES Standard Support to include SONET/SDH and updated footnote 2.
		DC and Switching Characteristics	Added footnote to ESD Performance table.
		Updated SERDES Power Supply Requirements table and footnotes.	
		Updated Maximum I/O Buffer Speed table.	
		Updated Pin-to-Pin Performance table.	
		Updated sysCLOCK PLL Timing table.	
		Updated DLL timing table.	
		Updated High-Speed Data Transmitter tables.	
		Updated High-Speed Data Receiver table.	
		Updated footnote for Receiver Total Jitter Tolerance Specification table.	
		Updated Periodic Receiver Jitter Tolerance Specification table.	
		Updated SERDES External Reference Clock Specification table.	
		Updated PCI Express Electrical and Timing AC and DC Characteristics.	
		Deleted Reference Clock table for PCI Express Electrical and Timing AC and DC Characteristics.	
		Updated SMPTE AC/DC Characteristics Transmit table.	
		Updated Mini LVDS table.	
		Updated RSDS table.	
		Added Supply Current (Standby) table for EA devices.	
		Updated Internal Switching Characteristics table.	
		Updated Register-to-Register Performance table.	
		Added HDMI Electrical and Timing Characteristics data.	
		Updated Family Timing Adders table.	
		Updated sysCONFIG Port Timing Specifications table.	
		Updated Recommended Operating Conditions table.	
		Updated Hot Socket Specifications table.	
		Updated Single-Ended DC table.	
		Updated TRLVDS table and figure.	
Updated Serial Data Input Specifications table.			
Updated HDMI Transmit and Receive table.			
Ordering Information	Added LFE3-150EA "TW" devices and footnotes to the Commercial and Industrial tables.		
March 2010	01.6	Architecture	Added Read-Before-Write information.
		DC and Switching Characteristics	Added footnote #6 to Maximum I/O Buffer Speed table.
		Corrected minimum operating conditions for input and output differential voltages in the Point-to-Point LVDS table.	
		Pinout Information	Added pin information for the LatticeECP3-70EA and LatticeECP3-95EA devices.
		Ordering Information	Added ordering part numbers for the LatticeECP3-70EA and LatticeECP3-95EA devices.
Removed dual mark information.			

Компания «Океан Электроники» предлагает заключение долгосрочных отношений при поставках импортных электронных компонентов на взаимовыгодных условиях!

Наши преимущества:

- Поставка оригинальных импортных электронных компонентов напрямую с производств Америки, Европы и Азии, а так же с крупнейших складов мира;
- Широкая линейка поставок активных и пассивных импортных электронных компонентов (более 30 млн. наименований);
- Поставка сложных, дефицитных, либо снятых с производства позиций;
- Оперативные сроки поставки под заказ (от 5 рабочих дней);
- Экспресс доставка в любую точку России;
- Помощь Конструкторского Отдела и консультации квалифицированных инженеров;
- Техническая поддержка проекта, помощь в подборе аналогов, поставка прототипов;
- Поставка электронных компонентов под контролем ВП;
- Система менеджмента качества сертифицирована по Международному стандарту ISO 9001;
- При необходимости вся продукция военного и аэрокосмического назначения проходит испытания и сертификацию в лаборатории (по согласованию с заказчиком);
- Поставка специализированных компонентов военного и аэрокосмического уровня качества (Xilinx, Altera, Analog Devices, Intersil, Interpoint, Microsemi, Actel, Aeroflex, Peregrine, VPT, Syfer, Eurofarad, Texas Instruments, MS Kennedy, Miteq, Cobham, E2V, MA-COM, Hittite, Mini-Circuits, General Dynamics и др.);

Компания «Океан Электроники» является официальным дистрибьютором и эксклюзивным представителем в России одного из крупнейших производителей разъемов военного и аэрокосмического назначения «JONHON», а так же официальным дистрибьютором и эксклюзивным представителем в России производителя высокотехнологичных и надежных решений для передачи СВЧ сигналов «FORSTAR».



JONHON

«JONHON» (основан в 1970 г.)

Разъемы специального, военного и аэрокосмического назначения:

(Применяются в военной, авиационной, аэрокосмической, морской, железнодорожной, горно- и нефтедобывающей отраслях промышленности)

«FORSTAR» (основан в 1998 г.)

ВЧ соединители, коаксиальные кабели, кабельные сборки и микроволновые компоненты:

(Применяются в телекоммуникациях гражданского и специального назначения, в средствах связи, РЛС, а так же военной, авиационной и аэрокосмической отраслях промышленности).



Телефон: 8 (812) 309-75-97 (многоканальный)

Факс: 8 (812) 320-03-32

Электронная почта: ocean@oceanchips.ru

Web: <http://oceanchips.ru/>

Адрес: 198099, г. Санкт-Петербург, ул. Калинина, д. 2, корп. 4, лит. А