



MIC5800/5801

4/8-Bit Parallel-Input Latched Drivers

Final Information

General Description

The MIC5800/5801 latched drivers are high-voltage, high-current integrated circuits comprised of four or eight CMOS data latches, a bipolar Darlington transistor driver for each latch, and CMOS control circuitry for the common CLEAR, STROBE, and OUTPUT ENABLE functions.

The bipolar/MOS combination provides an extremely low-power latch with maximum interface flexibility. MIC5800 contains four latched drivers; MIC5801 contains eight latched drivers.

Data input rates are greatly improved in these devices. With a 5V supply, they will typically operate at better than 5MHz. With a 12V supply, significantly higher speeds are obtained. The CMOS inputs are compatible with standard CMOS, PMOS, and NMOS circuits. TTL or DTL circuits may require the use of appropriate pull-up resistors. The bipolar

outputs are suitable for use with relays, solenoids, stepping motors, LED or incandescent displays, and other high-power loads. Both units have open-collector outputs and integral diodes for inductive load transient suppression. The output transistors are capable of sinking 500mA and will sustain at least 50V in the OFF state. Because of limitations on package power dissipation, the simultaneous operation of all drivers at maximum rated current can only be accomplished by a reduction in duty cycle. Outputs may be paralleled for higher load current capability.

Features

- 4.4MHz Minimum Data Input Rate
- High-Voltage, Current Sink Outputs
- Output Transient Protection
- CMOS, PMOS, NMOS, and TTL Compatible Inputs
- Internal Pull-Down Resistors
- Low-Power CMOS Latches

Ordering Information

Part Number		Temperature Range	Package
Standard	Pb-Free		
MIC5800BN	MIC5800YN	- 40°C to + 85°C	14-Pin Plastic DIP
MIC5800BM	MIC5800YM	- 40°C to + 85°C	14-Pin SOIC
MIC5801BN	MIC5801YN	- 40°C to +85°C	22-Pin Plastic DIP
5962-8764001WA ¹		- 55°C to +125°C	22-Pin Cerdip
MIC5801BV	MIC5801YV	- 40°C to + 85°C	28-Pin PLCC
MIC5801BWM	MIC5801YWM	- 40°C to +85°C	24-Pin SOIC

¹Standard Military Drawing number for MIC5801AJBQ

Functional Diagram



Typical Input

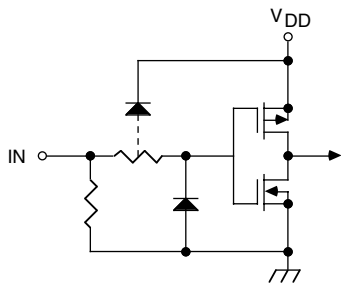

Absolute Maximum Ratings: (Notes 1–6)

at +25°C Free-Air Temperature

Output Voltage, V_{CE}	50V
Supply Voltage, V_{DD}	15V
Input Voltage Range, V_{IN}	-0.3V to $V_{DD} + 0.3V$
Continuous Collector Current, I_C	500mA
Package Power Dissipation:	
MIC5800 Plastic DIP (Note 1)	2.1W
MIC5801 Plastic DIP (Note 2)	2.5W
MIC5800 SOIC (Note 3)	1.0W
MIC5801 PLCC (Note 4)	2.25W
MIC5801 CERDIP (Note 5)	3.1W
MIC5801 Wide SOIC (Note 6)	1.4 Watt
Operating Temperature Range, T_A	-40°C to +85°C
Storage Temperature Range, T_S	-65°C to +125°C

- Note 1: Derate at 16.7 mW/°C above $T_A = +25^\circ\text{C}$
- Note 2: Derate at 20 mW/°C above $T_A = +25^\circ\text{C}$
- Note 3: Derate at 8.5 mW/°C above $T_A = +25^\circ\text{C}$
- Note 4: Derate at 18.2 mW/°C above $T_A = +25^\circ\text{C}$
- Note 5: Derate at 25 mW/°C above $T_A = +25^\circ\text{C}$
- Note 6: Derate at 11 mW/°C above $T_A = +25^\circ\text{C}$
- Note 7: Micrel CMOS devices have input-static protection but are susceptible to damage when exposed to extremely high static electrical charges.

Pin Configuration

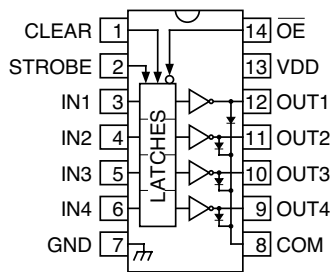

MIC5800BN, BM

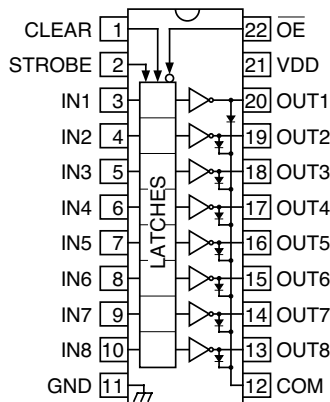

MIC5801BN, AJBQ

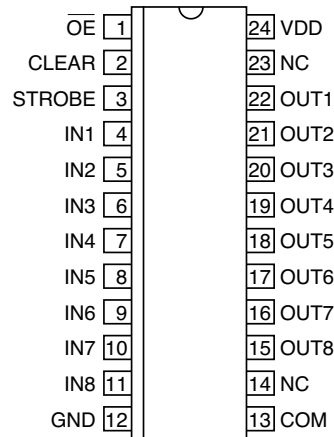

MIC5801BWM

Pin Configurations (continued)



MIC5801BV

Allowable Output Current As A Function of Duty Cycle

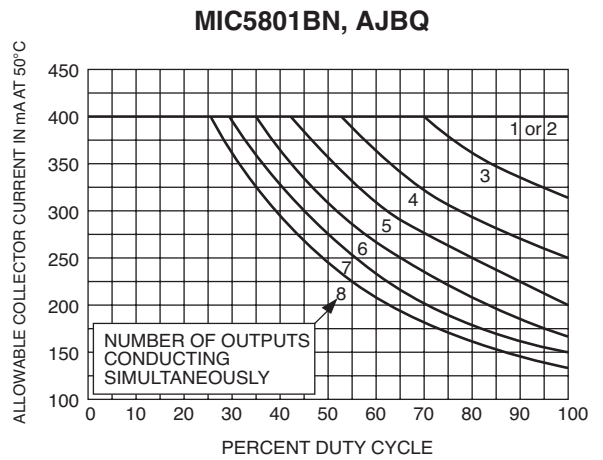
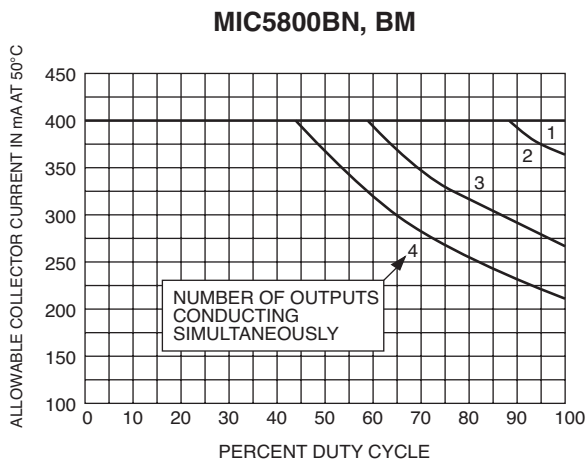

Electrical Characteristics (Note 1): at $T_A = +25^\circ\text{C}$, $V_{DD} = 5\text{V}$ (unless otherwise noted)

Characteristic	Symbol	Test Conditions	Limits			Units
			Min.	Typ.	Max.	
Output Leakage Current	I_{CEX}	$V_{CE} = 50\text{ V}, T_A = +25^\circ\text{C}$			50	μA
		$V_{CE} = 50\text{ V}, T_A = +70^\circ\text{C}$			100	
Collector-Emitter Saturation Voltage	$V_{CE(SAT)}$	$I_C = 100\text{ mA}$		0.9	1.1	V
		$I_C = 200\text{ mA}$		1.1	1.3	
		$I_C = 350\text{ mA}, V_{DD} = 7.0\text{ V}$		1.3	1.6	
Input Voltage	$V_{IN(0)}$				1.0	V
	$V_{IN(1)}$	$V_{DD} = 12\text{ V}$	10.5			
		$V_{DD} = 10\text{ V}$	8.5			
		$V_{DD} = 5.0\text{ V}$ (See Note)	3.5			
Input Resistance	R_{IN}	$V_{DD} = 12\text{ V}$	50	200		$\text{k}\Omega$
		$V_{DD} = 10\text{ V}$	50	300		
		$V_{DD} = 5.0\text{ V}$	50	600		
Supply Current	$I_{DD(ON)}$ (Each Stage)	$V_{DD} = 12\text{ V}, \text{Outputs Open}$		1.0	2.0	mA
		$V_{DD} = 10\text{ V}, \text{Outputs Open}$		0.9	1.7	
		$V_{DD} = 5.0\text{ V}, \text{Outputs Open}$		0.7	1.0	
	$I_{DD(OFF)}$ (Total)	$V_{DD} = 12\text{ V}, \text{Outputs Open}, \text{Inputs} = 0\text{ V}$			200	μA
$V_{DD} = 5.0\text{ V}, \text{Outputs Open}, \text{Inputs} = 0\text{ V}$			50	100		
Clamp Diode Leakage Current	I_R	$V_R = 50\text{ V}, T_A = +25^\circ\text{C}$			50	μA
		$V_R = 50\text{ V}, T_A = +70^\circ\text{C}$			100	
Clamp Diode Forward Voltage	V_F	$I_F = 350\text{ mA}$		1.7	2.0	V

NOTE : Operation of these devices with standard TTL or DTL may require the use of appropriate pull-up resistors to insure a minimum logic "1".
NOTE 1: Specification for packaged product only.

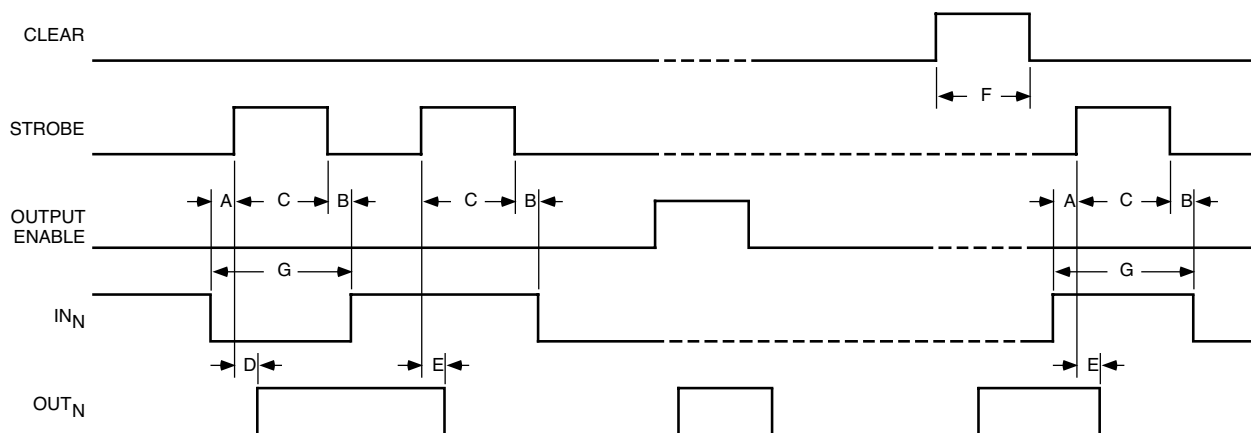

Timing Conditions

(Logic Levels are V_{DD} and Ground)

- A. Minimum data active time before strobe enabled (data set-up time) 50ns
- B. Minimum data active time after strobe disabled (data hold time) 50ns
- C. Minimum strobe pulse width 125ns
- D. Typical time between strobe activation and output on to off transition 500ns
- E. Typical time between strobe activation and output off to on transition 500ns
- F. Minimum clear pulse width 300ns
- G. Minimum data pulse width 225ns

Truth Table

IN _N	Strobe	Clear	Output Enable	OUT _N	
				t-1	t
0	1	0	0	X	OFF
1	1	0	0	X	ON
X	X	1	X	X	OFF
X	X	X	1	X	OFF
X	0	0	0	ON	ON
X	0	0	0	OFF	OFF

X = Irrelevant
 t-1 = previous output state
 t = present output state

Information present at an input is transferred to its latch when the STROBE is high. A high CLEAR input will set all latches to the output OFF condition regardless of the data or STROBE input levels. A high OUTPUT ENABLE will set all outputs to the off condition, regardless of any other input conditions. When the OUTPUT ENABLE is low, the outputs depend on the state of their respective latches.

Typical Application

Unipolar Stepper-Motor Drive



UNIPOLAR WAVE DRIVE



UNIPOLAR 2-PHASE DRIVE

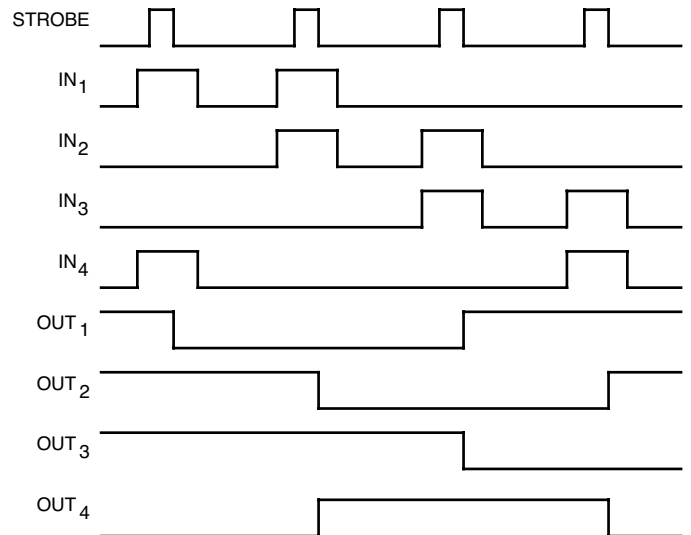

Typical Applications

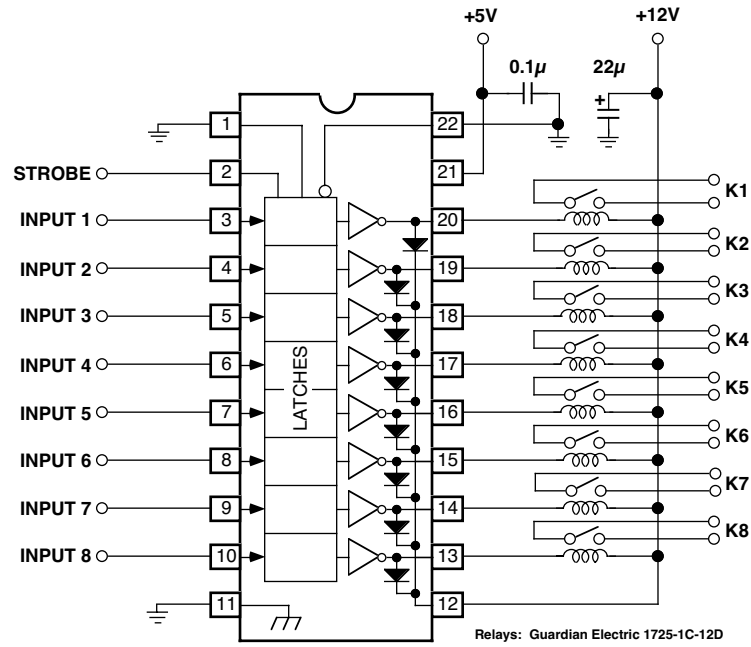

MIC5801 Relay Driver



Note:
Lamp inrush current is approximately 10x lamp operating current.

MIC5800 Incandescent/Halogen Lamp Driver

Package Information

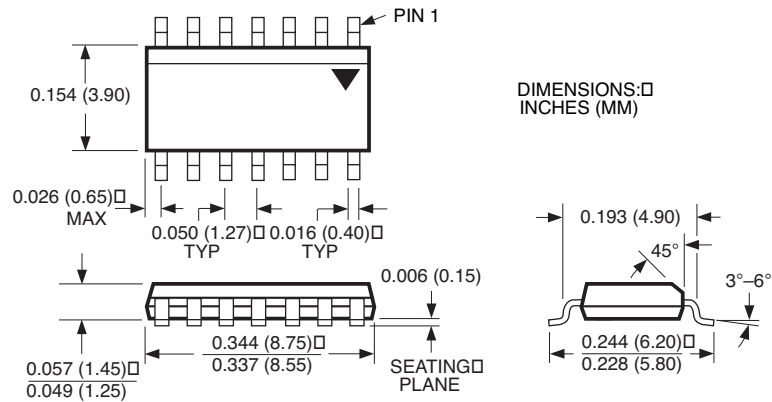

14-Pin SOIC (M)

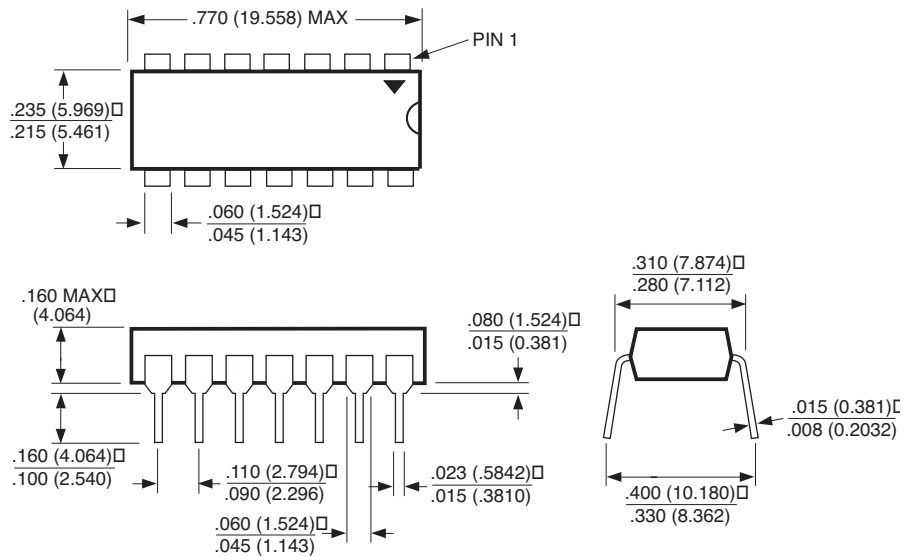

14-Pin Plastic DIP (N)



22-Pin Plastic DIP (N)



22-Pin Ceramic DIP (J)

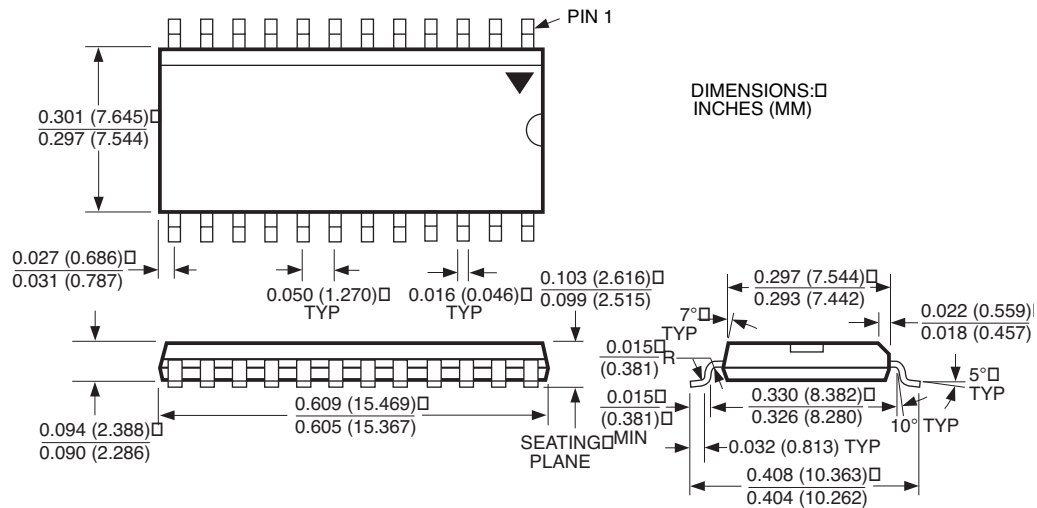

24-Pin SOIC (M)

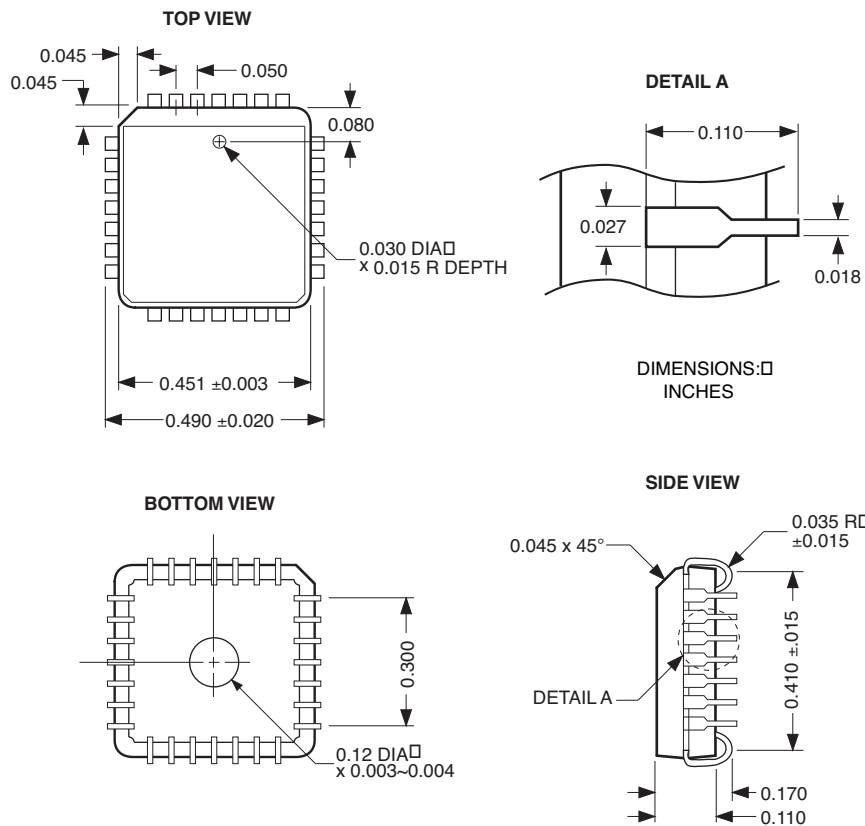

28-Pin PLCC (V)

MICREL INC. 2180 FORTUNE DRIVE SAN JOSE, CA 95131 USA

TEL + 1 (408) 944-0800 FAX + 1 (408) 474-1000 WEB <http://www.micrel.com>

This information furnished by Micrel in this data sheet is believed to be accurate and reliable. However no responsibility is assumed by Micrel for its use. Micrel reserves the right to change circuitry and specifications at any time without notification to the customer.

Micrel Products are not designed or authorized for use as components in life support appliances, devices or systems where malfunction of a product can reasonably be expected to result in personal injury. Life support devices or systems are devices or systems that (a) are intended for surgical implant into the body or (b) support or sustain life, and whose failure to perform can be reasonably expected to result in a significant injury to the user. A Purchaser's use or sale of Micrel Products for use in life support appliances, devices or systems is a Purchaser's own risk and Purchaser agrees to fully indemnify Micrel for any damages resulting from such use or sale.

© 1998 Micrel Incorporated

Компания «Океан Электроники» предлагает заключение долгосрочных отношений при поставках импортных электронных компонентов на взаимовыгодных условиях!

Наши преимущества:

- Поставка оригинальных импортных электронных компонентов напрямую с производств Америки, Европы и Азии, а так же с крупнейших складов мира;
- Широкая линейка поставок активных и пассивных импортных электронных компонентов (более 30 млн. наименований);
- Поставка сложных, дефицитных, либо снятых с производства позиций;
- Оперативные сроки поставки под заказ (от 5 рабочих дней);
- Экспресс доставка в любую точку России;
- Помощь Конструкторского Отдела и консультации квалифицированных инженеров;
- Техническая поддержка проекта, помощь в подборе аналогов, поставка прототипов;
- Поставка электронных компонентов под контролем ВП;
- Система менеджмента качества сертифицирована по Международному стандарту ISO 9001;
- При необходимости вся продукция военного и аэрокосмического назначения проходит испытания и сертификацию в лаборатории (по согласованию с заказчиком);
- Поставка специализированных компонентов военного и аэрокосмического уровня качества (Xilinx, Altera, Analog Devices, Intersil, Interpoint, Microsemi, Actel, Aeroflex, Peregrine, VPT, Syfer, Eurofarad, Texas Instruments, MS Kennedy, Miteq, Cobham, E2V, MA-COM, Hittite, Mini-Circuits, General Dynamics и др.);

Компания «Океан Электроники» является официальным дистрибьютором и эксклюзивным представителем в России одного из крупнейших производителей разъемов военного и аэрокосмического назначения «JONHON», а так же официальным дистрибьютором и эксклюзивным представителем в России производителя высокотехнологичных и надежных решений для передачи СВЧ сигналов «FORSTAR».



JONHON

«JONHON» (основан в 1970 г.)

Разъемы специального, военного и аэрокосмического назначения:

(Применяются в военной, авиационной, аэрокосмической, морской, железнодорожной, горно- и нефтедобывающей отраслях промышленности)

«FORSTAR» (основан в 1998 г.)

ВЧ соединители, коаксиальные кабели, кабельные сборки и микроволновые компоненты:

(Применяются в телекоммуникациях гражданского и специального назначения, в средствах связи, РЛС, а так же военной, авиационной и аэрокосмической отраслях промышленности).



Телефон: 8 (812) 309-75-97 (многоканальный)

Факс: 8 (812) 320-03-32

Электронная почта: ocean@oceanchips.ru

Web: <http://oceanchips.ru/>

Адрес: 198099, г. Санкт-Петербург, ул. Калинина, д. 2, корп. 4, лит. А