

# USB Buccaneer®

IP68

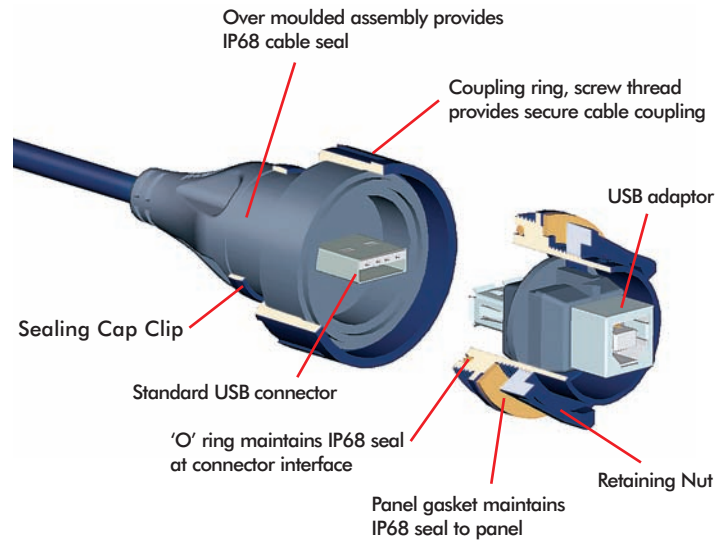

- IP68 rated
- USB version 2.0 performance
- Plug and play capability
- Visual mating indication
- Shielded system
- Single and double ended cables
- Screw coupling
- PCB versions
- ▶ Dust and waterproof sealing when mated
- ▶ Low and high speed bus connection, 1.5Mbps to 480Mbps
- ▶ Hot pluggable, standard 4 pole interface
- ▶ Alignment indicator reduces risk of damage during mating
- ▶ High noise immunity and EMI protection
- ▶ Suitable for PC and peripheral configuration
- ▶ Secure, proven locking system
- ▶ Direct mounting or via adaptor leads

**SEALED USB CABLES - SINGLE ENDED**



Single ended sealed cable assembly

- IP68 'A' type USB connector to standard 'B' type USB connector, mates with all panel mount connectors
- IP68 'B' type USB connector to standard 'A' type USB connector, mates with all panel mount connectors
- Available in 2m, 3m and 5m lengths

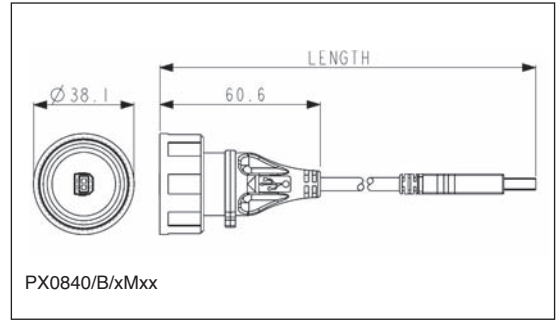
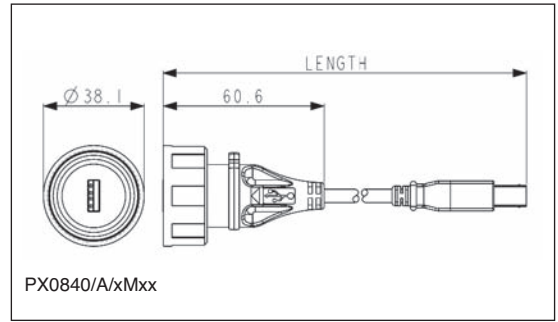

Part No.	Length	Description
PX0840/A/2M00	2m	IP68 A type USB to standard B type USB
PX0840/A/3M00	3m	IP68 A type USB to standard B type USB
PX0840/A/5M00	5m	IP68 A type USB to standard B type USB
PX0840/B/2M00	2m	IP68 B type USB to standard A type USB
PX0840/B/3M00	3m	IP68 B type USB to standard A type USB
PX0840/B/5M00	5m	IP68 B type USB to standard A type USB

**SEALED USB CABLES - DOUBLE ENDED**



Double ended sealed cable assembly

- IP68 'A' type USB connector to IP68 'B' type USB connector
- Mates with all panel mount connectors
- Available in 2m, 3m and 5m lengths

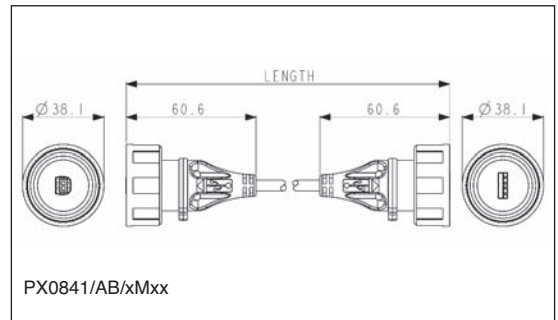

Part No.	Length	Description
PX0841/AB/2M00	2m	IP68 A type USB to IP68 B type USB
PX0841/AB/3M00	3m	IP68 A type USB to IP68 B type USB
PX0841/AB/5M00	5m	IP68 A type USB to IP68 B type USB

USB Buccaneer®

FRONT PANEL MOUNTING CONNECTOR



- PX0842/A - USB 'A' type IP68 connector
- PX0842/B - USB 'B' type IP68 connector
- Opposite connector to rear of panel
- Mates with PX0840 and PX0841 cable connectors

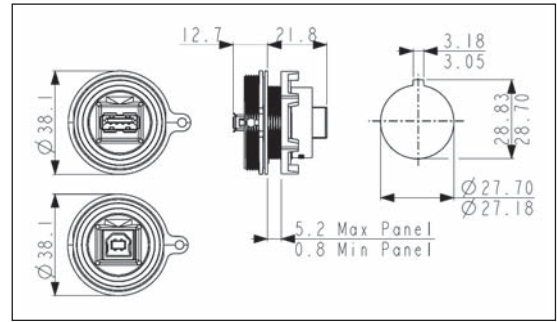

Part No.	Description
PX0842/A	IP68 A type USB, front panel mounted. Sealed A type at front of panel, standard B type at rear.
PX0842/B	IP68 B type USB, front panel mounted. Sealed B type at front of panel, standard A type at rear.

FRONT PANEL MOUNTING CONNECTOR



- PX0843/A - USB 'A' type IP68 connector
- PX0843/B - USB 'B' type IP68 connector
- Leaded with 5 way crimp connector
- Mates with PX0840 and PX0841 cable connectors

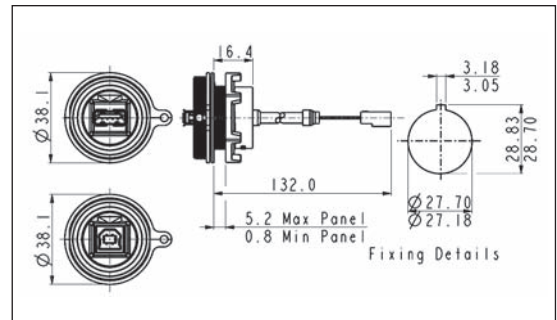

Part No.	Description
PX0843/A	IP68 A type USB, front panel mounted. Sealed A type at front of panel, 5 way crimp connector at rear.
PX0843/B	IP68 B type USB, front panel mounted. Sealed B type at front of panel, 5 way crimp connector at rear.
PX0460/A	As PX0843/A with exposed braid for use with PX0465 screening can
PX0460/B	As PX0843/B with exposed braid for use with PX0465 screening can

FRONT PANEL MOUNTING CONNECTOR



- IP68 Sealed through panel
- PX0844/A - USB 'A' type IP68 connector
- PX0844/B - USB 'B' type IP68 connector
- Standard USB interface plug options to rear of panel
- 500mm standard cable length, other lengths available
- Mates with PX0840 and PX0841

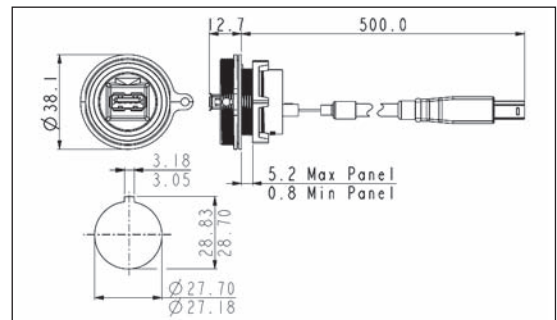

Part No.	Description
PX0844/A/OM50/A	IP68 A type USB, sealed through panel, Sealed 'A' type at front of panel, standard 'A' type at rear
PX0844/A/OM50/B	IP68 A type USB, sealed through panel, Sealed 'A' type at front of panel, standard 'B' type at rear
PX0844/B/OM50/A	IP68 B type USB, sealed through panel, Sealed 'B' type at front of panel, standard 'A' type at rear
PX0844/B/OM50/B	IP68 B type USB, sealed through panel, Sealed 'B' type at front of panel, standard 'B' type at rear

BUCCANEER DATA

**USB Buccaneer®**

**REAR PANEL MOUNTING CONNECTOR**



- PX0848/A - USB 'A' type IP68 connector
- PX0848/B - USB 'B' type IP68 connector
- Opposite connector to rear of panel
- Mates with PX0840 and PX0841 cable connectors

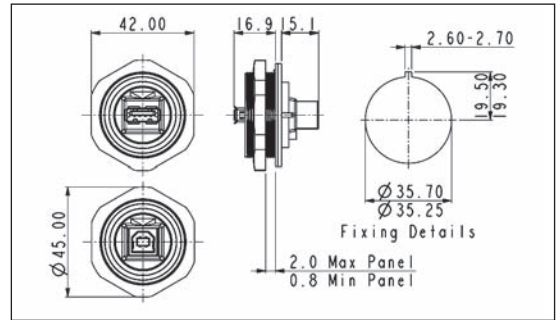

Part No.	Description
PX0848/A	IP68 A type USB, rear panel mounted. Sealed A type at front of panel, standard B type at rear.
PX0848/B	IP68 B type USB, rear panel mounted. Sealed B type at front of panel, standard A type at rear.

**REAR PANEL MOUNTING CONNECTOR**



- PX0849/A - USB 'A' type IP68 connector
- PX0849/B - USB 'B' type IP68 connector
- Leaded with 5 way header
- Mates with PX0840 and PX0841 cable connectors

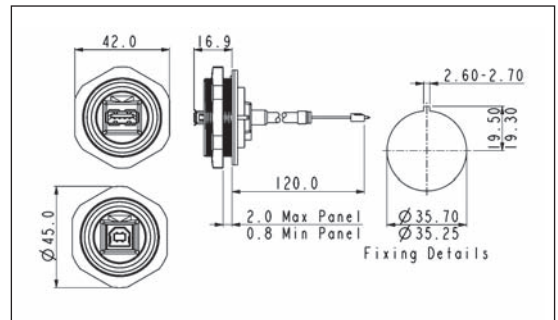

Part No.	Description
PX0849/A	IP68 A type USB, rear panel mounted. Sealed A type at front of panel, 5 way header at rear.
PX0849/B	IP68 B type USB, rear panel mounted. Sealed B type at front of panel, 5 way header at rear.

**REAR PANEL MOUNTING CONNECTOR - PCB DIRECT MOUNT**



- PX0845/A - USB 'A' type IP68 connector
- PX0845/B - USB 'B' type IP68 connector
- PCB contacts at rear
- Direct PCB mount
- Mates with PX0840 and PX0841 cable connectors

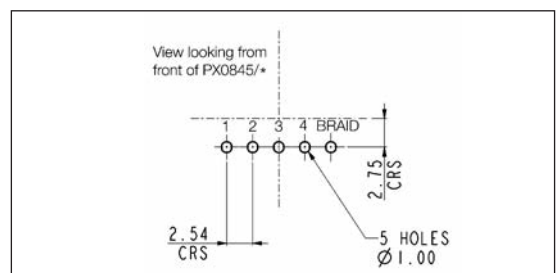
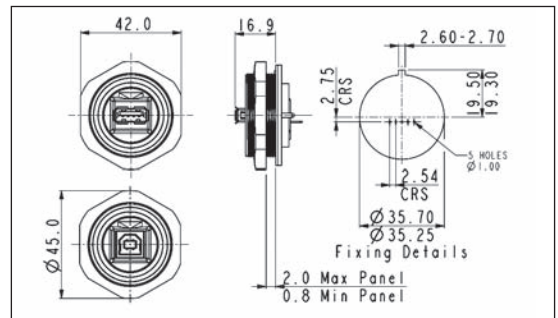

Part No.	Description
PX0845/A	IP68 A type USB, rear panel mounted. Sealed A type at front of panel, direct mount PCB contacts at rear.
PX0845/B	IP68 B type USB, rear panel mounted. Sealed B type at front of panel, direct mount PCB contacts at rear.

BUCCANEER DATA



## USB Buccaneer®

### PCB ADAPTOR LEADS



- Standard A and B type USB connectors to 5 way crimp adaptor leads
- 5 way headers, 2.54mm pitch, horizontal or vertical mounting

Part No.	Description
14193	USB 'A' type to 5 way crimp connector
14194	USB 'B' type to 5 way crimp connector
14191	5 way PCB header straight
14192	5 way PCB header right angle

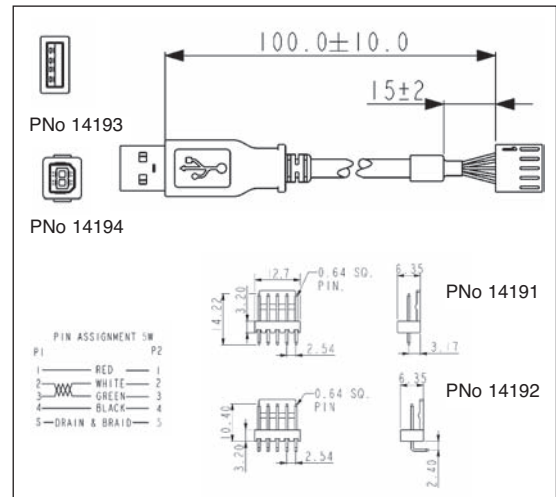

### ACCESSORIES



- Sealing caps to maintain IP68 rating when connectors are not in use
- PX0835 for cable connectors PX0840 & PX0841
- PX0733 for front panel mount connectors PX0842, PX0843 & PX0844
- PX0711 for rear panel mount connectors PX0848, PX0849 & PX0845

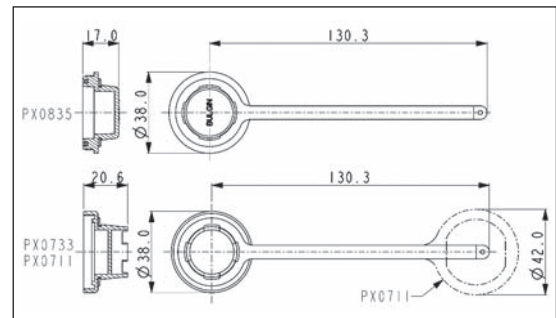

Part No.	Description
PX0835	Sealing Cap for cable connectors (PX0840, PX0841)
PX0733	Sealing Cap for front panel mounting connector (PX0842, PX0843)
PX0711	Sealing Cap for rear panel mounting connector (PX0848, PX0849, PX0845)

### USB FLASH DRIVE COVER



- For use with USB Flash Drives
- Maintains IP68 rating when mated with panel connector
- For use with 'A' type connectors: PX0842, PX0843, PX0845, PX0848 & PX0849
- Internal accommodation 17.5 x 14.0 x 83mm approx.

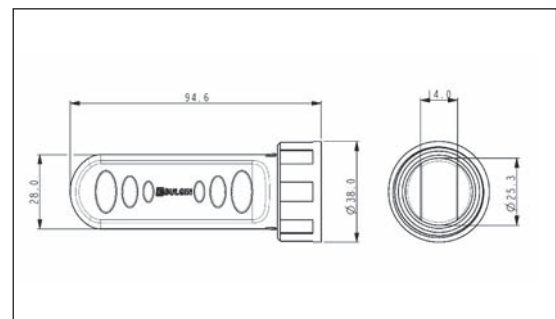

### SCREENING CAN



- Maintains cable screening directly to panel
- Screening can clips around the panel fixing nut
- For use on PX0460/A and PX0460/B

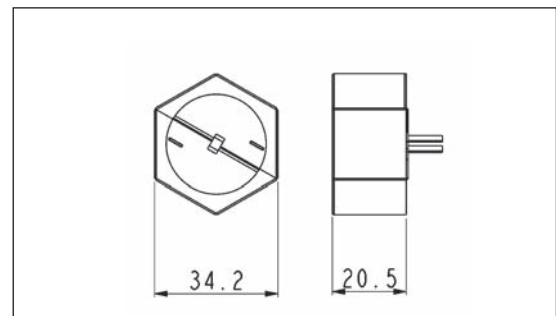

BUCCANEER DATA

**SPECIFICATION**

**Cables & connectors**

**Mechanical**

Sealing IP68, EN60529  
 Operating temperature 0°C to +70°C

**Electrical**

No. of poles 4  
 Current rating 1A  
 Voltage rating 30Vac (RMS)  
 Contact resistance 30mΩ max.  
 Performance USB version 2.0

**Materials - Overmoulded**

Overmould material PVC (black)  
 Flammability rating UL94V-0

**Materials - Re-wireable and Panel Connectors**

Shell material Steel  
 Shell plating Nickel  
 Contact material Copper Alloy  
 Contact plating 30 micro inch Gold  
 Connector body & locking ring Polyester  
 Panel connector Nylon 6  
 Flammability rating UL94V-0  
 'O' rings Silicon  
 Panel Gasket - round Silicon  
 Panel Gasket - square Neoprene  
 Mating cycles 1,000  
**RoHS** Compliant

**Materials - cable**

Cable Jacket PVC (black)  
 Screen Tinned copper braid  
 Flammability UL94V-0  
**RoHS** Compliant

Length:	Dia	Conductors	
		Signal	Power
2m	4.8mm	2 x 28AWG	2 x 24AWG
3m	5.0mm	2 x 28AWG	2 x 22AWG
5m	5.2mm	2 x 25AWG	2 x 20AWG

**PCB adaptor leads**

**Electrical**

No. of conductors 4  
 Current rating 1A  
 Voltage rating 30Vac (RMS)  
 Contact resistance <10mΩ max.  
 PCB pitch 2.54mm

**Materials**

Moulding Polycarbonate  
 Flammability UL94V-0  
 Contact material Copper Alloy  
 Contact plating 30 micro inch Gold  
 Wire insulation PVC (black)  
 Flammability UL94V-0  
 Conductors 4 x 28AWG  
 Operating temperature 0°C to +70°C  
 Mating cycles 1,000  
**RoHS** Compliant

**Cable construction - PX0840, PX0841**

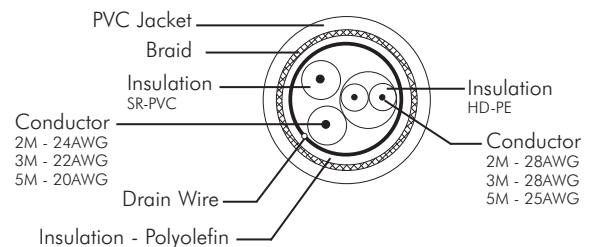

Компания «Океан Электроники» предлагает заключение долгосрочных отношений при поставках импортных электронных компонентов на взаимовыгодных условиях!

Наши преимущества:

- Поставка оригинальных импортных электронных компонентов напрямую с производств Америки, Европы и Азии, а так же с крупнейших складов мира;
- Широкая линейка поставок активных и пассивных импортных электронных компонентов (более 30 млн. наименований);
- Поставка сложных, дефицитных, либо снятых с производства позиций;
- Оперативные сроки поставки под заказ (от 5 рабочих дней);
- Экспресс доставка в любую точку России;
- Помощь Конструкторского Отдела и консультации квалифицированных инженеров;
- Техническая поддержка проекта, помощь в подборе аналогов, поставка прототипов;
- Поставка электронных компонентов под контролем ВП;
- Система менеджмента качества сертифицирована по Международному стандарту ISO 9001;
- При необходимости вся продукция военного и аэрокосмического назначения проходит испытания и сертификацию в лаборатории (по согласованию с заказчиком);
- Поставка специализированных компонентов военного и аэрокосмического уровня качества (Xilinx, Altera, Analog Devices, Intersil, Interpoint, Microsemi, Actel, Aeroflex, Peregrine, VPT, Syfer, Eurofarad, Texas Instruments, MS Kennedy, Miteq, Cobham, E2V, MA-COM, Hittite, Mini-Circuits, General Dynamics и др.);

Компания «Океан Электроники» является официальным дистрибьютором и эксклюзивным представителем в России одного из крупнейших производителей разъемов военного и аэрокосмического назначения «JONHON», а так же официальным дистрибьютором и эксклюзивным представителем в России производителя высокотехнологичных и надежных решений для передачи СВЧ сигналов «FORSTAR».



## JONHON

«JONHON» (основан в 1970 г.)

Разъемы специального, военного и аэрокосмического назначения:

(Применяются в военной, авиационной, аэрокосмической, морской, железнодорожной, горно- и нефтедобывающей отраслях промышленности)

«FORSTAR» (основан в 1998 г.)

ВЧ соединители, коаксиальные кабели, кабельные сборки и микроволновые компоненты:

(Применяются в телекоммуникациях гражданского и специального назначения, в средствах связи, РЛС, а так же военной, авиационной и аэрокосмической отраслях промышленности).



Телефон: 8 (812) 309-75-97 (многоканальный)

Факс: 8 (812) 320-03-32

Электронная почта: [ocean@oceanchips.ru](mailto:ocean@oceanchips.ru)

Web: <http://oceanchips.ru/>

Адрес: 198099, г. Санкт-Петербург, ул. Калинина, д. 2, корп. 4, лит. А