



Is Now Part of



ON Semiconductor®

To learn more about ON Semiconductor, please visit our website at
www.onsemi.com

Please note: As part of the Fairchild Semiconductor integration, some of the Fairchild orderable part numbers will need to change in order to meet ON Semiconductor's system requirements. Since the ON Semiconductor product management systems do not have the ability to manage part nomenclature that utilizes an underscore (_), the underscore (_) in the Fairchild part numbers will be changed to a dash (-). This document may contain device numbers with an underscore (_). Please check the ON Semiconductor website to verify the updated device numbers. The most current and up-to-date ordering information can be found at www.onsemi.com. Please email any questions regarding the system integration to Fairchild_questions@onsemi.com.

ON Semiconductor and the ON Semiconductor logo are trademarks of Semiconductor Components Industries, LLC dba ON Semiconductor or its subsidiaries in the United States and/or other countries. ON Semiconductor owns the rights to a number of patents, trademarks, copyrights, trade secrets, and other intellectual property. A listing of ON Semiconductor's product/patent coverage may be accessed at www.onsemi.com/site/pdf/Patent-Marking.pdf. ON Semiconductor reserves the right to make changes without further notice to any products herein. ON Semiconductor makes no warranty, representation or guarantee regarding the suitability of its products for any particular purpose, nor does ON Semiconductor assume any liability arising out of the application or use of any product or circuit, and specifically disclaims any and all liability, including without limitation special, consequential or incidental damages. Buyer is responsible for its products and applications using ON Semiconductor products, including compliance with all laws, regulations and safety requirements or standards, regardless of any support or applications information provided by ON Semiconductor. "Typical" parameters which may be provided in ON Semiconductor data sheets and/or specifications can and do vary in different applications and actual performance may vary over time. All operating parameters, including "Typicals" must be validated for each customer application by customer's technical experts. ON Semiconductor does not convey any license under its patent rights nor the rights of others. ON Semiconductor products are not designed, intended, or authorized for use as a critical component in life support systems or any FDA Class 3 medical devices or medical devices with a same or similar classification in a foreign jurisdiction or any devices intended for implantation in the human body. Should Buyer purchase or use ON Semiconductor products for any such unintended or unauthorized application, Buyer shall indemnify and hold ON Semiconductor and its officers, employees, subsidiaries, affiliates, and distributors harmless against all claims, costs, damages, and expenses, and reasonable attorney fees arising out of, directly or indirectly, any claim of personal injury or death associated with such unintended or unauthorized use, even if such claim alleges that ON Semiconductor was negligent regarding the design or manufacture of the part. ON Semiconductor is an Equal Opportunity/Affirmative Action Employer. This literature is subject to all applicable copyright laws and is not for resale in any manner.

FSA221 — USB2.0 High-Speed (480Mbps) and Audio Switches with Negative Signal Capability

Features

- HS-USB: 4Ω Typical On Resistance
- HS-USB: 4.5pF Typical On Capacitance
- Audio: 3Ω Typical On Resistance
- -3db Bandwidth: > 720MHz
- Low Power Consumption
- Power-off Protection on Common D+/R, D-/L Ports
- Automatically Detects V_{bus} for Switch Path Selection

Applications

- Cell Phone, PDA, Digital Camera, and Notebook
- LCD Monitor, TV, and Set-Top Box

Description

The FSA221 is a Double-Pole, Double Throw (DPDT) multiplexer that combines a low-distortion audio and a USB2.0 High-Speed (HS) switch path. This configuration enables audio and USB data to share a common connector port. The architecture is designed to allow audio signals to swing below ground. This means a common USB and headphone jack can be used for personal media players and portable peripheral devices.

Since USB2.0 is an industry standard for shared data-path in portable devices, the FSA221 also incorporates a V_{bus} detection capability. The FSA221 includes a power-off feature to minimize current consumption when V_{bus} is not present. This power-off circuitry is available for the common D+/R, D-/L ports only. Typical applications involve switching in portables and consumer applications, such as cell phones, digital cameras, and notebooks with hubs or controllers.

Ordering Information

Part Number	Package Number	Top Mark	Package Description
FSA221L10X	MAC10A	GK	10-Lead MicroPak™, JEDEC MO-255, 1.6 x 2.1mm
FSA221MUX	MUA10A	FSA221	10-Lead MSOP JEDEC MO-187, 3.0 mm Wide
FSA221UMX	UMLP10A	GL	10-Lead Quad, Ultrathin MLP, 1.4 x 1.8mm

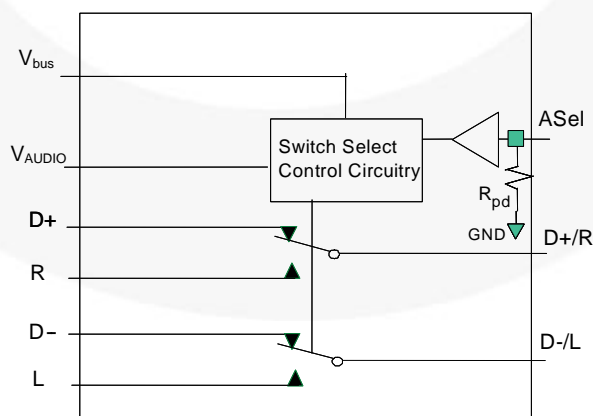

Figure 1. Analog Symbol

Pin Assignments

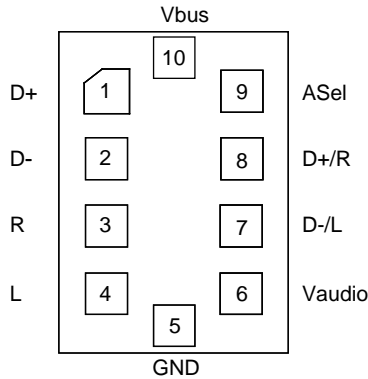

Figure 2. 10-Lead MicroPak™

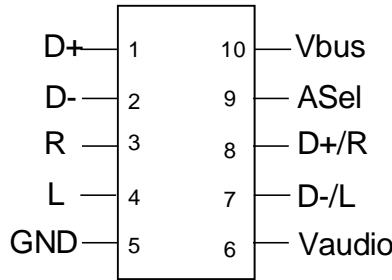

Figure 3. 10-Lead MSOP

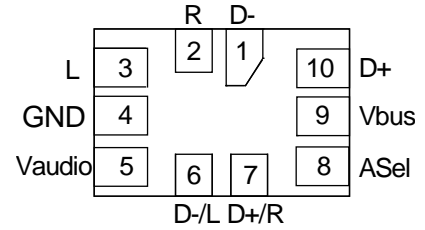

Figure 4. 10-Lead UMLP

Pin Descriptions

Name	Description
V_{audio}	Power supply (Audio)
V_{bus}	Power supply (USB) and auto USB switch-path select
A_{Sel}	Audio select to override auto USB detect when V_{AUDIO} supply is present
D+, D-	USB data bus input sources
R, L	Audio right and left input sources
D+/R, D-/L	USB and audio common connector ports

Truth Table

$A_{\text{Sel}}^{(1)}$	V_{audio}	V_{bus}	L, R	D+, D-
	LOW	LOW	OFF	OFF
	LOW	HIGH ⁽²⁾	OFF	ON
	HIGH ⁽²⁾	LOW	ON	OFF
LOW	HIGH ⁽²⁾	HIGH ⁽²⁾	OFF	ON
HIGH	HIGH ⁽²⁾	HIGH ⁽²⁾	ON	OFF

Notes:

1. A_{Sel} - Internal resistor to GND provides auto- V_{bus} detect if there is no external connection. Forcing A_{Sel} HIGH when V_{AUDIO} is present overrides the USB path even if V_{bus} is present.
2. HIGH - Value is the threshold as defined to meet USB2.0 V_{bus} requirements and audio supply threshold in a system (see DC Tables).

Functional Description

The FSA221 is a combined USB and audio switch that enables sharing the D+/D- lines of a USB connector with stereo audio CODEC outputs. The switch is optimized for high-speed USB signals and includes an automatic V_{bus} -detection circuit. When a USB connector, rather than a headphone, is connected to the ultra-portable device the switch is automatically configured for high-speed USB data transfer. If no V_{bus} is detected, and yet V_{AUDIO} is present, the switch is configured for the low-distortion audio switch path. The audio switch path also handles negative signals (down to -2V), which eliminates the need for large coupling capacitors.

For those applications where the V_{bus} is generated as a self-powered device or where V_{bus} is not removed, the A_{Sel} pin provides the ability to switch, under software

control, to the audio path. The A_{Sel} pin is internally terminated by a resistor to GND (typical value $3M\Omega$) and requires no connection for the standard ultra-portable (cell-phone, MP3, or portable media player). In an application where the supply to the FSA221 V_{bus} pin is not guaranteed to be removed, a GPIO pin can be used to switch out of high-speed USB mode into audio mode, using the A_{Sel} pin.

The FSA221 V_{bus} pin must be connected directly to V_{bus} or a supply > 3.8V, not an LDO regulated down to 3.6V or a V_{bat} -generated supply that may fall below 3.8V in normal operation.

Application Diagram

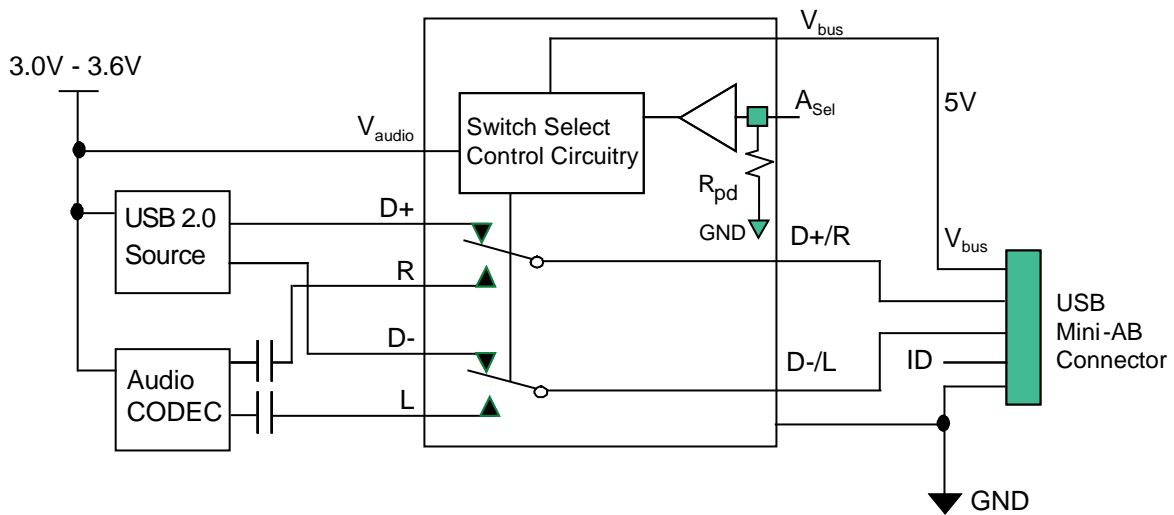

Figure 5. Typical Application

Absolute Maximum Ratings

Stresses exceeding the absolute maximum ratings may damage the device. The device may not function or be operable above the recommended operating conditions and stressing the parts to these levels is not recommended. In addition, extended exposure to stresses above the recommended operating conditions may affect device reliability. The absolute maximum ratings are stress ratings only.

Symbol	Parameter	Min.	Max.	Unit	
$V_{\text{AUDIO}}/$ V_{BUS}	Supply Voltage	-0.5	6.0	V	
V_{SW}	Switch I/O Voltage ⁽³⁾	D+, D-, D+/R, D-/L Pins	$V_{\text{BUS}} - 7.0$	$V_{\text{BUS}} + 0.3$	V
		R, L, Pins	$V_{\text{AUDIO}} - 7.0$	$V_{\text{AUDIO}} - 0.3$	V
A_{SEL}	Control Input Voltage ⁽³⁾	-0.5	6.0	V	
I_{IK}	Input Clamp Diode Current	-50		mA	
I_{SW}	Switch I/O Current (Continuous)	USB		50	mA
		Audio		50	
I_{SWPEAK}	Peak Switch Current (Pulsed at 1ms Duration, <10% Duty Cycle)	USB		100	mA
		Audio		100	
T_{STG}	Storage Temperature Range	-65	+150	°C	
T_{J}	Maximum Junction Temperature		+150	°C	
T_{L}	Lead Temperature (Soldering, 10 seconds)		+260	°C	
MSL	Moisture Sensitivity Level (JEDEC J-STD-020A)	Level 1			
ESD	Human Body Model (JEDEC: JESD22-A114)	I/O to GND		7500	V
		All Other Pins		7500	
		V_{AUDIO} V_{BUS} to GND		12000	
	Charged Device Model (JEDEC: JESD22-C101)		2000		

Note:

- The input and output negative ratings may be exceeded if the input and output diode current ratings are observed.

Recommended Operating Conditions

The Recommended Operating Conditions table defines the conditions for actual device operation. Recommended operating conditions are specified to ensure optimal performance to the datasheet specifications. Fairchild does not recommend exceeding them or designing to Absolute Maximum Ratings.

Symbol	Parameter	Minimum	Maximum
V_{AUDIO}	Supply Voltage	3.0V	4.2V
V_{BUS}	Supply Voltage	4.25V	5.50V
A_{Sel}	Control Input Voltage	0V	V_{AUDIO}
V_{SW}	Switch I/O Voltage	$V_{\text{AUDIO}} - 6.5V$	$V_{\text{AUDIO}} - 0.3V$
		$V_{\text{BUS}} - 6.5V$	V_{BUS}
T_{A}	Operating Temperature	-40°C	85°C
θ_{JA}	Thermal Resistance (Free Air)	MicroPak™	330°C / W (Estimated)

DC Electrical Characteristics

All typical values are at $T_A=25^\circ\text{C}$ unless otherwise specified.

Symbol	Parameter	V_{AUDIO} (V)	Condition	$T_A=-40^\circ\text{C}$ to $+85^\circ\text{C}$			Unit
				Min.	Typ.	Max.	
Common Pins							
V_{IK}	Clamp Diode Voltage	3.0	$I_{\text{IK}}=-18\text{mA}$			-1.2	V
V_{IH}	Control Input Voltage HIGH	3.0 to 3.6		1.2			
V_{IL}	Control Input Voltage LOW	3.0 to 3.6				0.5	
I_{IN}	A_{Sel} Input HIGH Current	3.6	$V_{\text{IN}}=3.6\text{V}$	-1		10	μA
			$V_{\text{IN}}=0\text{V}$	-1		1	
I_{OFF}	Power-Off Leakage Current (Common Port Only D+/R, D-/L)	$V_{\text{AUDIO}}=$ $V_{\text{BUS}}=0\text{V}$	Common Port (D+/R, D-/L), $V_{\text{SW}}=0\text{V}$ to 5.5V			10	μA
$I_{\text{NO(OFF)}}$	Off-Leakage Current of Port D+, D-, R, L	4.2	$V_{\text{BUS}}=0\text{V}$, 5.5V, D+/R, D-/L=0.3V, $V_{\text{AUDIO}}-0.3\text{V}$, D+, D-, R, L=0.3V, $V_{\text{AUDIO}}-0.3\text{V}$ or Floating, Figure 11	-50	1	50	nA
$I_{\text{NC(ON)}}$	On-Leakage Current of Port D+/R or D-/L	4.2	$V_{\text{bus}}=0\text{V}$, 5.5V, D+/R, D-/L=0.3V, $V_{\text{AUDIO}}-0.3\text{V}$, D+, D-, R, L=Floating, Figure 12	-50	1	50	nA
R_{PD}	A_{Sel} Internal Pull-Down Resistor				3		$\text{M}\Omega$
USB Switch Path		V_{BUS} (V)					
	USB Analog Signal Range			0		3.6	V
R_{ONUSB}	HS Switch On Resistance ⁽⁴⁾	4.25	$V_{\text{D+}/\text{D-}}=0\text{V}$, 0.4V, $I_{\text{ON}}=-8\text{mA}$, $V_{\text{AUDIO}}=3\text{V}$		4	6	Ω
ΔR_{ONUSB}	HS Delta R_{ON} ^(5,6)	4.25	$V_{\text{D+}/\text{D-}}=0\text{V}$, $I_{\text{ON}}=-8\text{mA}$, $V_{\text{AUDIO}}=3\text{V}$		0.4		Ω
Audio Switch Path		V_{AUDIO} (V)					
	Audio Analog Signal Range			V_{AUDIO} - 5.5		V_{AUDIO}	V
R_{ONAudio}	Audio Switch On Resistance ⁽⁴⁾	3.0	$V_{\text{L}/\text{R}}=-2\text{V}$, 0V, 0.7V, $V_{\text{BUS}}=0\text{V}$, $V_{\text{AUDIO}}-0.7\text{V}$, V_{AUDIO} , $I_{\text{ON}}=-26\text{mA}$		3	5	Ω
$\Delta R_{\text{ONAudio}}$	Audio Delta R_{ON} ⁽⁵⁾	3.0	$V_{\text{L}/\text{R}}=0.7\text{V}$ $I_{\text{ON}}=-26\text{mA}$		0.4		Ω
$R_{\text{FLAT(Audio)}}$	Audio R_{ON} Flatness ⁽⁷⁾	3.0	$I_{\text{ON}}=-26\text{mA}$		1.5	2.5	Ω
Power Supply							
V_{busth}	V_{BUS} Threshold Voltage			3.2		3.8	V
V_{audieth}	V_{AUDIO} Threshold			0.5		1.5	V
$I_{\text{CC(Audio)}}$	Quiescent Supply Current (Audio)	4.2	$V_{\text{ASel}}=0$ to V_{AUDIO} , $I_{\text{OUT}}=0$		6	10	μA
$I_{\text{CC}(V_{\text{bus}})}$	Quiescent Supply Current (V_{BUS})		$V_{\text{ASel}}=0$ to V_{AUDIO} , $I_{\text{OUT}}=0$, $V_{\text{BUS}}=5.5\text{V}$		12	20	μA
I_{CCT}	Increase in I_{CC} Current per Control Voltage and V_{CC}	4.2	$V_{\text{ASel}}=2.6\text{V}$, $V_{\text{BUS}}=\text{Floating}$		10	15	μA
			$V_{\text{ASel}}=1.8\text{V}$, $V_{\text{BUS}}=\text{Floating}$		14	18	

Notes:

- On resistance is determined by the voltage drop between the A and B pins at the indicated current through the switch.
- $\Delta R_{\text{ON}}=R_{\text{ON max}}-R_{\text{ON min}}$ measured at identical V_{CC} , temperature, and voltage. Worst-case signal path, audio, or USB channel, is characterized.
- Guaranteed by characterization, not production tested.
- Flatness is defined as the difference between the maximum and minimum values of on resistance over the specified range of conditions.

AC Electrical Characteristics

All typical value are for $V_{\text{AUDIO}}=3.3\text{V}$ and $V_{\text{bus}}=5.0$ at $T_{\text{A}}=25^{\circ}\text{C}$ unless otherwise specified.

Symbol	Parameter	$V_{\text{AUDIO}} / V_{\text{BUS}}$ (V)	Condition	$T_{\text{A}}=-40^{\circ}\text{C}$ to $+85^{\circ}\text{C}$			Unit
				Min.	Typ.	Max.	
t_{ONAUDIO1}	Turn-On Time $V_{\text{AUDIO}}\uparrow$ to Output	$V_{\text{BUS}}=0\text{V}$	$V_{\text{D+R, D-/L}}=1.0\text{V}$, $R_{\text{L}}=50\Omega$, $C_{\text{L}}=50\text{pF}$ Figure 13, Figure 15			10	μs
$t_{\text{OFFAUDIO1}}$	Turn-Off Time $V_{\text{BUS}}\uparrow$ to Output	$V_{\text{AUDIO}}=3.0$ for $V_{\text{BUS}}\uparrow$	$V_{\text{D+R, D-/L}}=1.0\text{V}$, $R_{\text{L}}=50\Omega$, $C_{\text{L}}=50\text{pF}$ Figure 13, Figure 15			10	μs
t_{ONAUDIO2}	Turn-On Time A_{Sel} to Output	$V_{\text{BUS}}=4.25\text{V}$ $V_{\text{AUDIO}}=3.0$	$V_{\text{D+R, D-/L}}=1.0\text{V}$, $R_{\text{L}}=50\Omega$, $C_{\text{L}}=50\text{pF}$ Figure 13, Figure 14			2	μs
$t_{\text{OFFAUDIO2}}$	Turn-Off Time A_{Sel} to Output	$V_{\text{BUS}}=4.25\text{V}$ $V_{\text{AUDIO}}=3.0$	$V_{\text{D+R, D-/L}}=1.0\text{V}$, $R_{\text{L}}=50\Omega$, $C_{\text{L}}=50\text{pF}$ Figure 13, Figure 14			2	μs
t_{ONAUDIO3}	Turn-On Time $V_{\text{BUS}}\downarrow$ to Output	$V_{\text{AUDIO}}=3.0$	$V_{\text{D+R, D-/L}}=1.0\text{V}$, $R_{\text{L}}=50\Omega$, $C_{\text{L}}=50\text{pF}$ Figure 13, Figure 15			10	μs
t_{ONUSB}	Turn-On Time $V_{\text{USB}}\uparrow$ to Output	$V_{\text{AUDIO}}=3.0$	$V_{\text{D+R, D-/L}}=1.0\text{V}$, $R_{\text{L}}=50\Omega$, $C_{\text{L}}=0\text{pF}$ Figure 13, Figure 15			10	μs
t_{OFFUSB}	Turn-Off Time $V_{\text{USB}}\downarrow$ to Output	$V_{\text{AUDIO}}=3.0$	$V_{\text{D+R, D-/L}}=1.0\text{V}$, $R_{\text{L}}=50\Omega$, $C_{\text{L}}=0\text{pF}$ Figure 13, Figure 15			10	μs
t_{PDUSB}	USB Switch Propagation Delay ⁽⁸⁾	$V_{\text{AUDIO}}=3.0$ $V_{\text{BUS}}=4.25\text{V}$	$R_{\text{L}}=50\Omega$, $C_{\text{L}}=0\text{pF}$, Figure 16		0.25		ns
X_{talkA}	Non-Adjacent Channel Crosstalk - Audio	$V_{\text{AUDIO}}=3.0$ $V_{\text{BUS}}=4.25\text{V}$	$f=20\text{kHz}$, $R_{\text{T}}=32\Omega$, $C_{\text{L}}=0\text{pF}$ Figure 7, Figure 21		-110		dB
BW	-3db Bandwidth - USB	$V_{\text{AUDIO}}=3.0$ $V_{\text{BUS}}=4.25\text{V}$	$R_{\text{T}}=50\Omega$, $C_{\text{L}}=0\text{pF}$, Signal 0dBm Figure 9, Figure 19		720		MHz
THD	Total Harmonic Distortion	$V_{\text{AUDIO}}=3.0$ $V_{\text{BUS}}=0\text{V}$	$f=20\text{Hz}$ to 20kHz , $R_{\text{L}}=32\Omega$, $V_{\text{IN}}=2V_{\text{pp}}$ Figure 24		0.05		%

Note:

8. Guaranteed by characterization, not production tested.

USB High-Speed-Related AC Electrical Characteristics

T_A= -40°C to +85°C.

Symbol	Parameter	V _{AUDIO} / V _{BUS} (V)	Conditions	Typ.	Unit
t _{SK(o)}	Channel-to-Channel Skew ⁽⁹⁾	V _{AUDIO} =3.0V V _{BUS} =4.25V	t _R =t _F =750ps (10-90%) at 240MHz C _L =0pF, R _L =50Ω Figure 17, Figure 18	35	ps
t _{SK(P)}	Skew of Opposite Transitions of the Same Output ⁽⁹⁾	V _{AUDIO} =3.0V V _{BUS} =4.25V	t _R =t _F =750ps (10-90%) at 240MHz C _L =0pF, R _L =50Ω Figure 17, Figure 18	35	
t _J	Total Jitter ⁽⁹⁾	V _{AUDIO} =3.0V V _{BUS} =4.25V	R _L =50Ω, C _L =50pF, t _R =t _F =500ps (10-90%) at 480Mbps (PRBS=2 ¹⁵ - 1)	130	ps

Note:

9. Guaranteed by characterization, not production tested.

Capacitance

T_A= -40°C to +85°C.

Symbol	Parameter	V _{AUDIO} / V _{BUS} (V)	Condition	Typ.	Unit
C _{IN (ASel)}	Control Pin Input Capacitance (A _{Sel})	V _{AUDIO} =3.0V, V _{BUS} =4.25V	V _{Bias} =0.2V	2.0	pF
C _{ON(D+/R, D-/L)}	D+/R, D-/L (Source Port) On Capacitance	V _{AUDIO} =3.0V, V _{BUS} =4.25V, A _{Sel} =0V (C _{ONUSB})	V _{Bias} =0.2V, f=240MHz, Figure 23	4.5	pF
		V _{AUDIO} =3.0V, V _{BUS} =4.25V, A _{Sel} =3.0V (C _{ONAudio})	V _{Bias} =0.2V, f=1MHz, Figure 23	9.0	
C _{OFF(D+, D-)}	USB Input Source Off Capacitance	V _{AUDIO} =3.0V, V _{BUS} =4.25V, A _{Sel} =3.0V	f=1MHz, Figure 22	1.5	pF
C _{OFF(R/L)}	Audio Input Source Off Capacitance	V _{AUDIO} =3.0V, V _{BUS} =4.25V, A _{Sel} =0V	f=1MHz, Figure 22	3.0	pF

Typical Characteristics

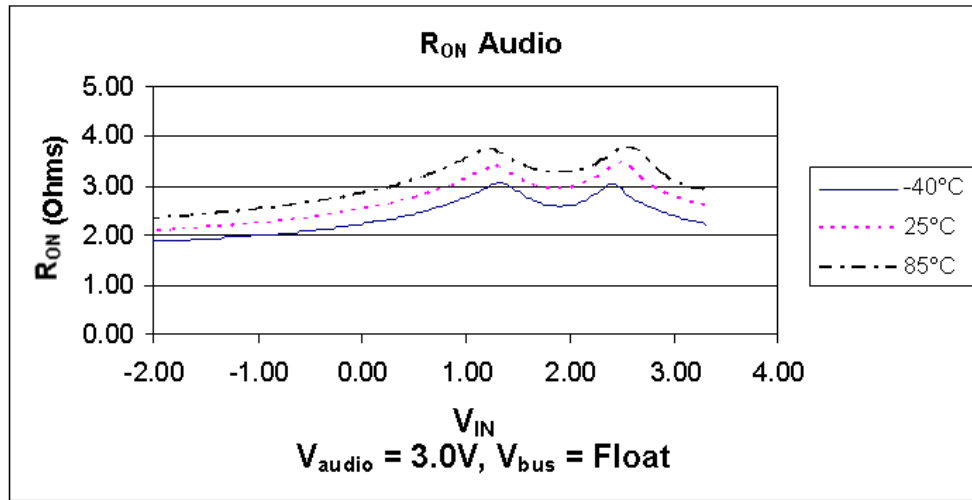

Figure 6. R_{ON} Audio, $V_{Audio}=3.0V$, $V_{BUS}=Float$

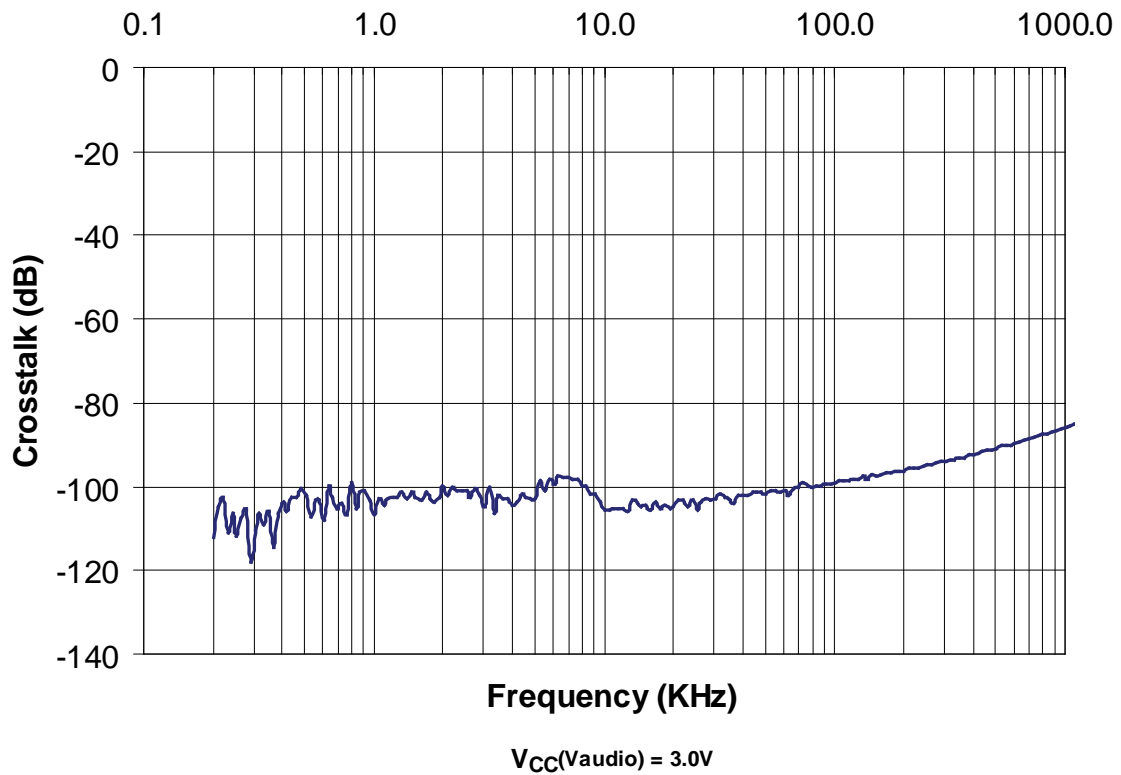

Figure 7. Non-Adjacent Channel Crosstalk – Audio

Typical Characteristics (Continued)

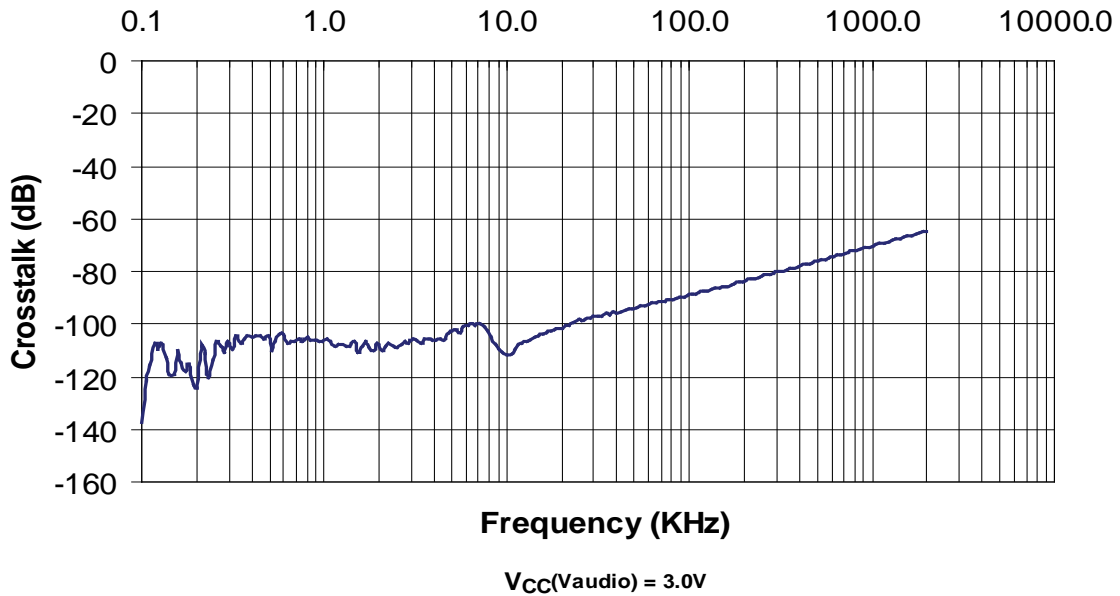

Figure 8. Off-Isolation – Audio

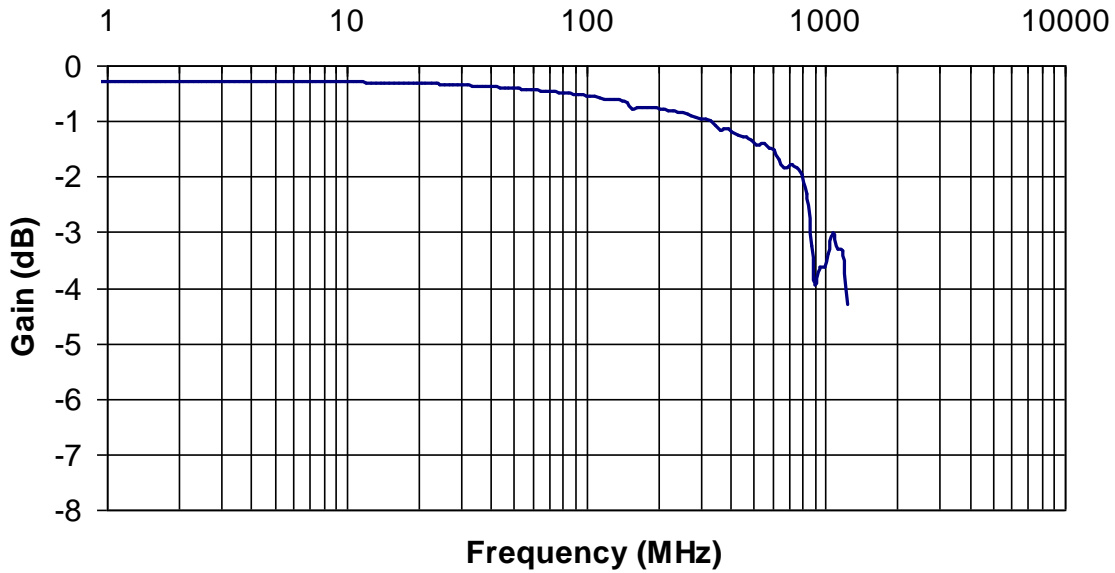

Figure #. Bandwidth Characterization, Frequency Response at $C_L = 0pF, V_{CC}(V_{bus}) = 4.25V$

Figure 9. Bandwidth, Gain vs. Frequency – USB

Test Diagrams

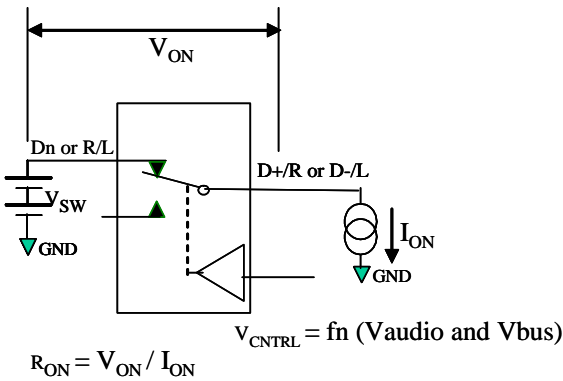

Figure 10. On Resistance

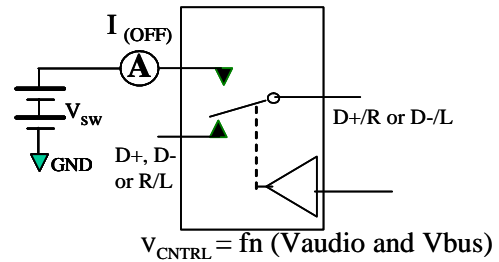

Figure 11. Off Leakage

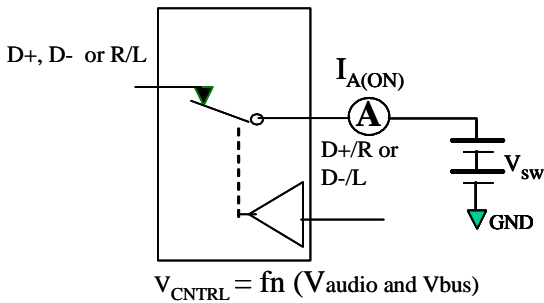

Figure 12. On Leakage

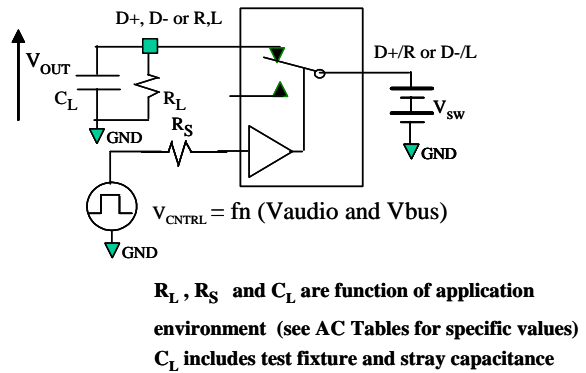

Figure 13. AC Test Circuit Load

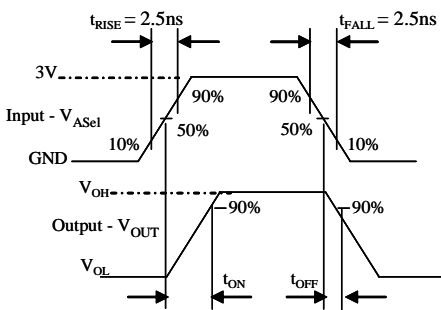

Figure 14. Turn-On / Turn-Off Waveforms (A_{Sel})

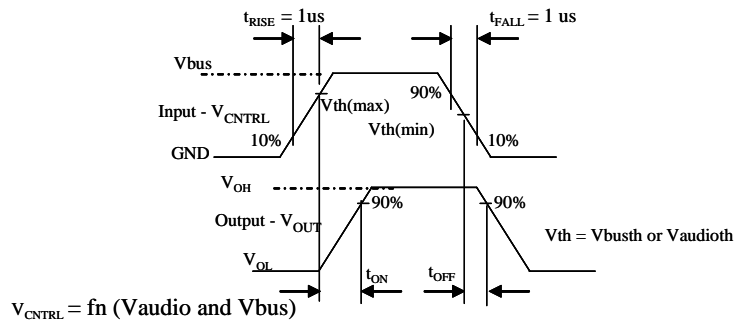

Figure 15. Turn-On / Turn-Off Waveforms (USB/Audio)

Test Diagrams (Continued)

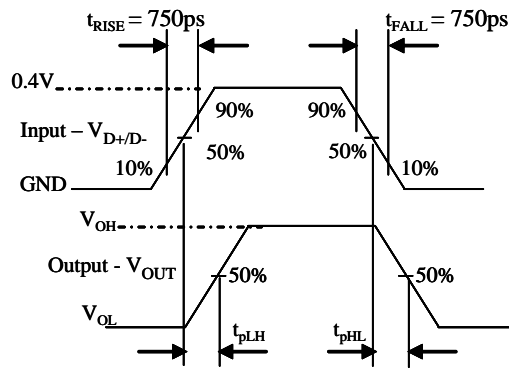

Figure 16. USB Switch Propagation Delay Waveforms

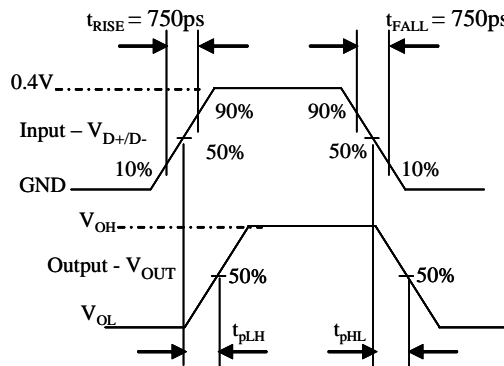

Figure 17. Pulse Skew: $t_{SK(P)} = |t_{pHL} - t_{pLH}|$

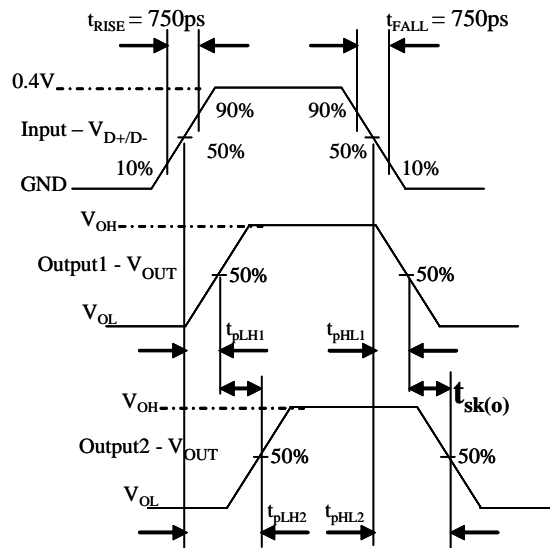

Figure 18. Output Skew: $t_{SK(O)} = |t_{pLH1} - t_{pLH2}|$ or $|t_{pHL1} - t_{pHL2}|$

Test Diagrams (Continued)

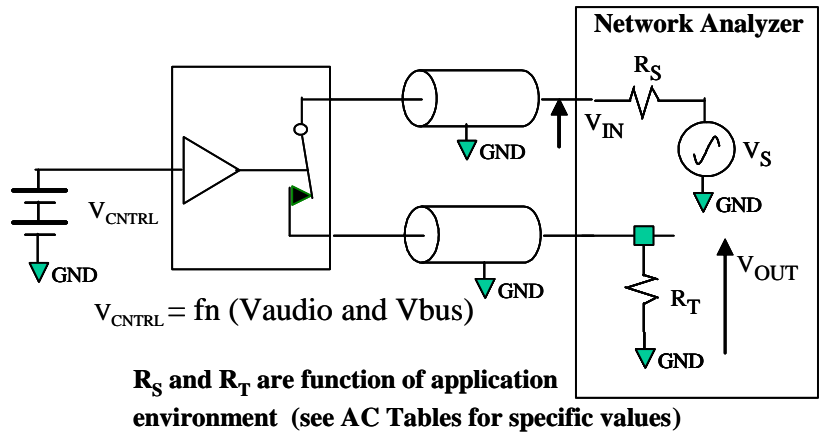

Figure 19. USB Bandwidth

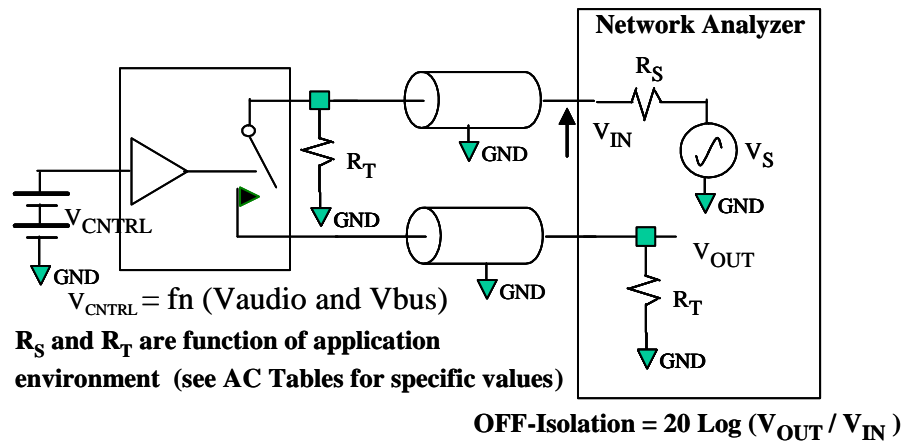

Figure 20. Channel Off Isolation

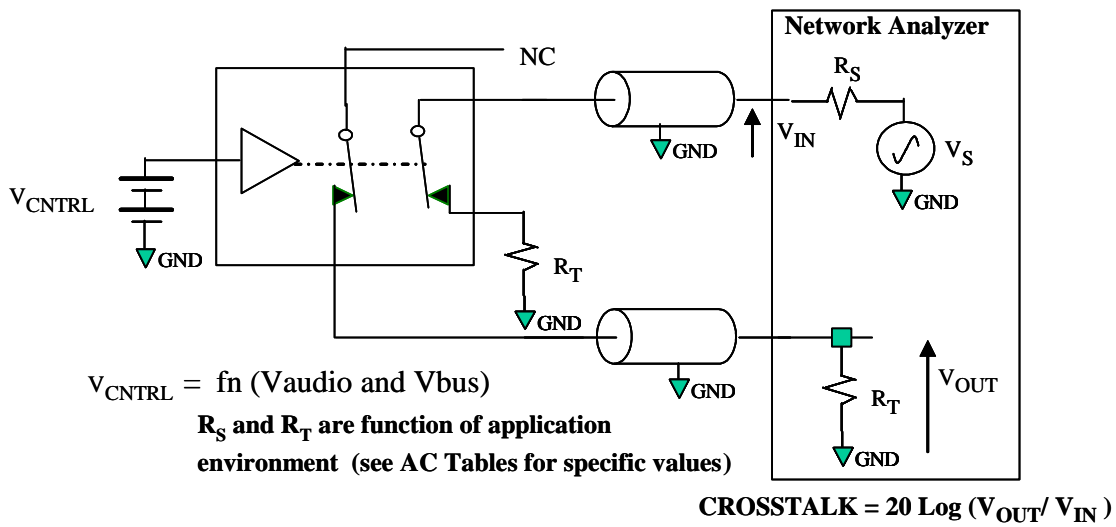

Figure 21. Non-Adjacent Channel-to-Channel Crosstalk

Test Diagrams (Continued)

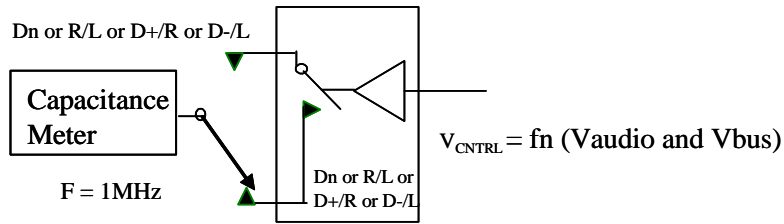

Figure 22. Channel Off Capacitance

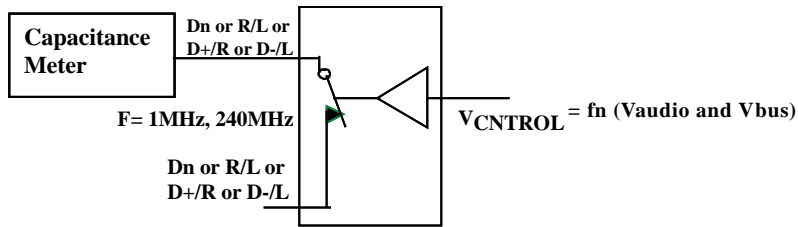

Figure 23. Channel On Capacitance

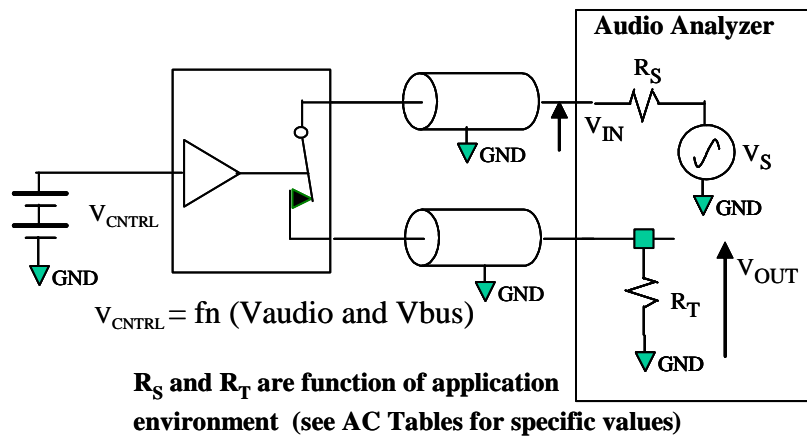

Figure 24. Total Harmonic Distortion

Physical Dimensions

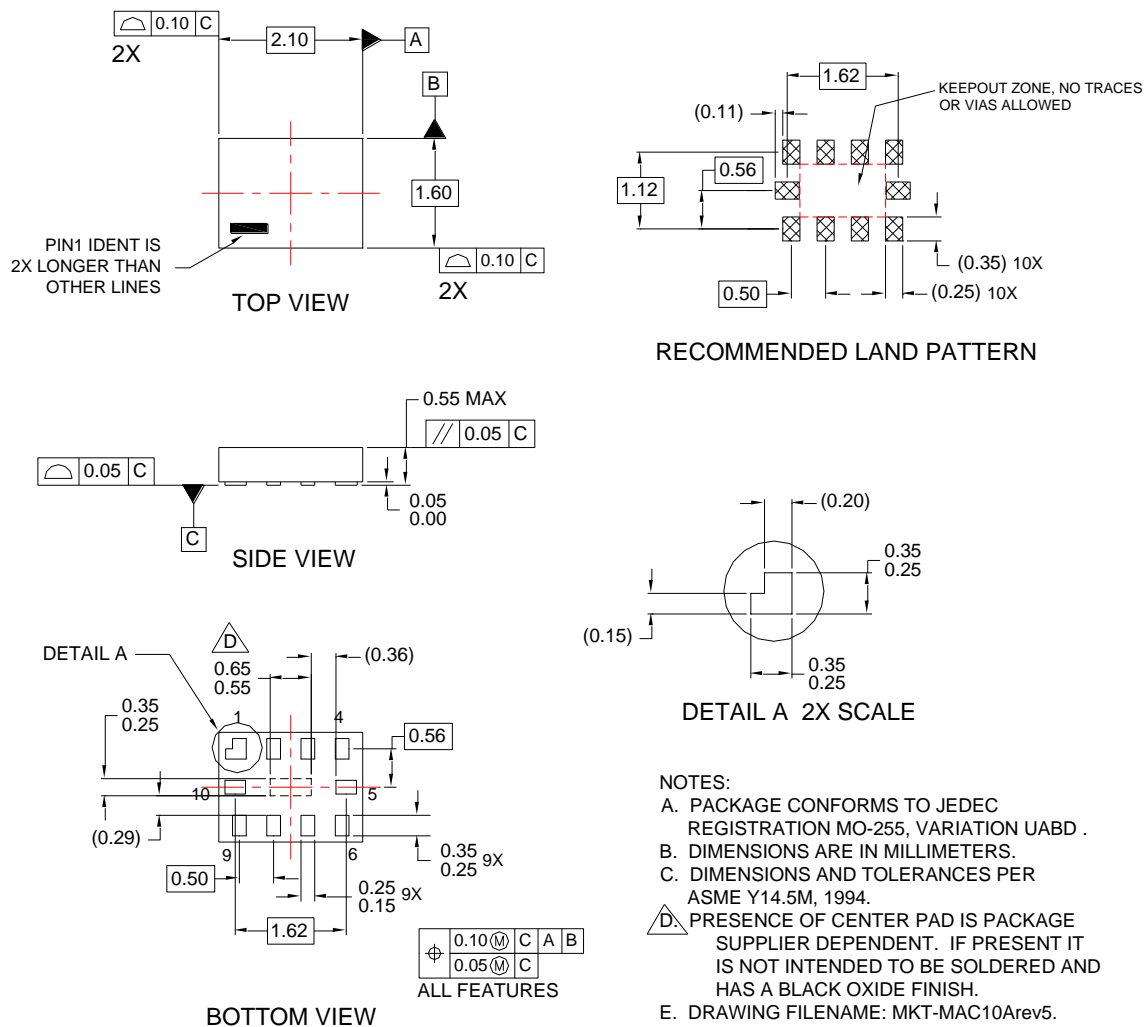

Figure 25. 10-Lead MicroPak™

Package Designator	Tape Section	Number Cavity	Cavity Status	Cover Tape Status
L10X	Leader (Start End)	125 (Typical)	Empty	Sealed
	Carrier	5000	Filled	Sealed
	Trailer (Hub End)	75 (Typical)	Empty	Sealed

Package drawings are provided as a service to customers considering Fairchild components. Drawings may change in any manner without notice. Please note the revision and/or date on the drawing and contact a Fairchild Semiconductor representative to verify or obtain the most recent revision. Package specifications do not expand the terms of Fairchild's worldwide terms and conditions, specifically the warranty therein, which covers Fairchild products.

Always visit Fairchild Semiconductor's online packaging area for the most recent package drawings:
<http://www.fairchildsemi.com/packaging/>.

For current tape and reel specifications, visit Fairchild Semiconductor's online packaging area:
http://www.fairchildsemi.com/products/logic/pdf/micropak_tr.pdf.

Physical Dimensions

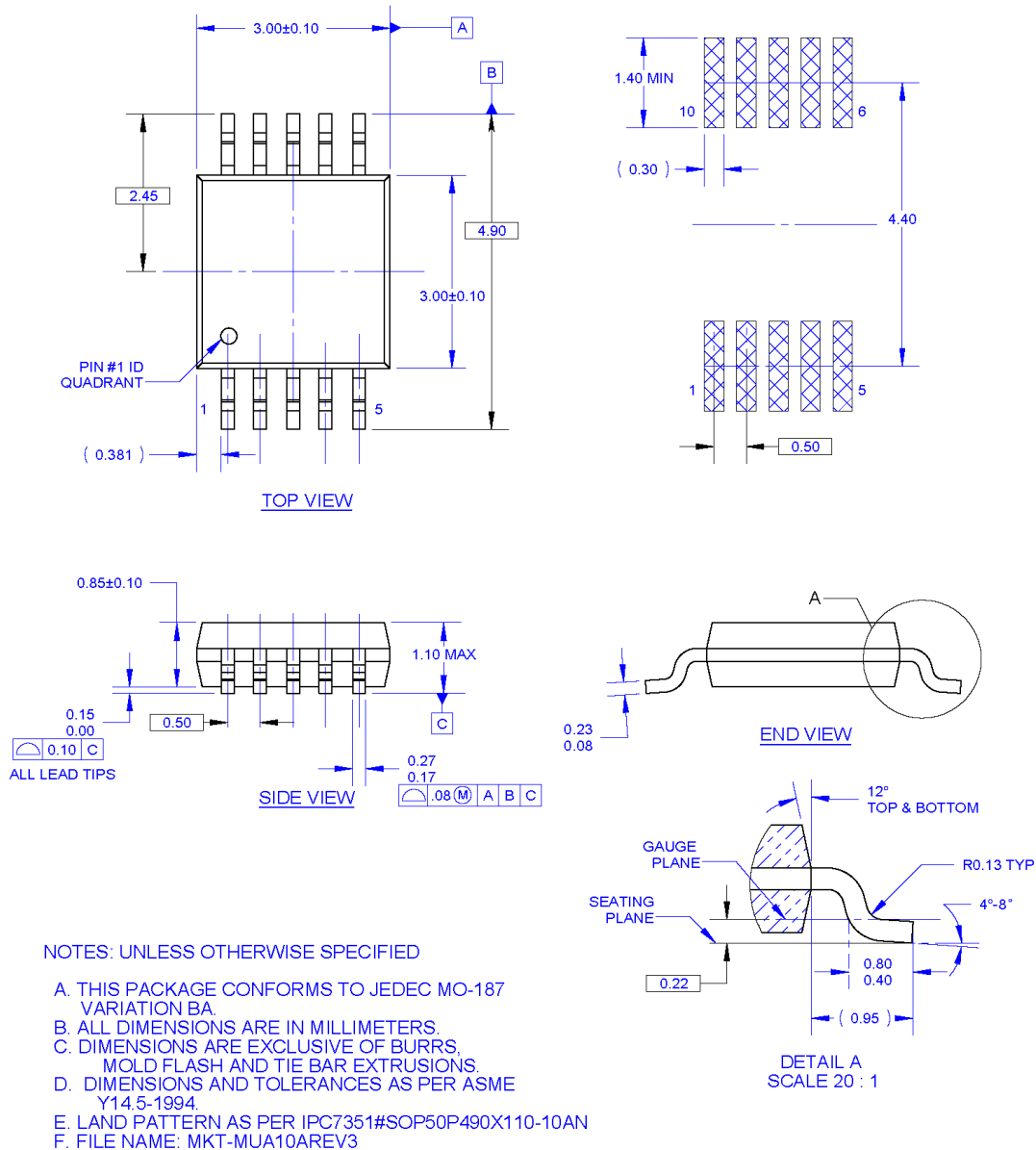

Figure 26. 10-Lead Molded Small Outline Package (MSOP)

Tape Size	A	B	C	D	N	W1	W2	W3
	13	0.059	0.512	0.795	7.008	0.448	0.724	0.486-0.606
(12mm)	(330)	(1.5)	(13)	(20.2)	(178)	(12.4)	(18.4)	(11.9-15.4)

Package drawings are provided as a service to customers considering Fairchild components. Drawings may change in any manner without notice. Please note the revision and/or date on the drawing and contact a Fairchild Semiconductor representative to verify or obtain the most recent revision. Package specifications do not expand the terms of Fairchild's worldwide terms and conditions, specifically the warranty therein, which covers Fairchild products.

Always visit Fairchild Semiconductor's online packaging area for the most recent package drawings:
<http://www.fairchildsemi.com/packaging/>.

For current tape and reel specifications, visit Fairchild Semiconductor's online packaging area:
http://www.fairchildsemi.com/products/analog/pdf/msop10_tr.pdf.

Physical Dimensions

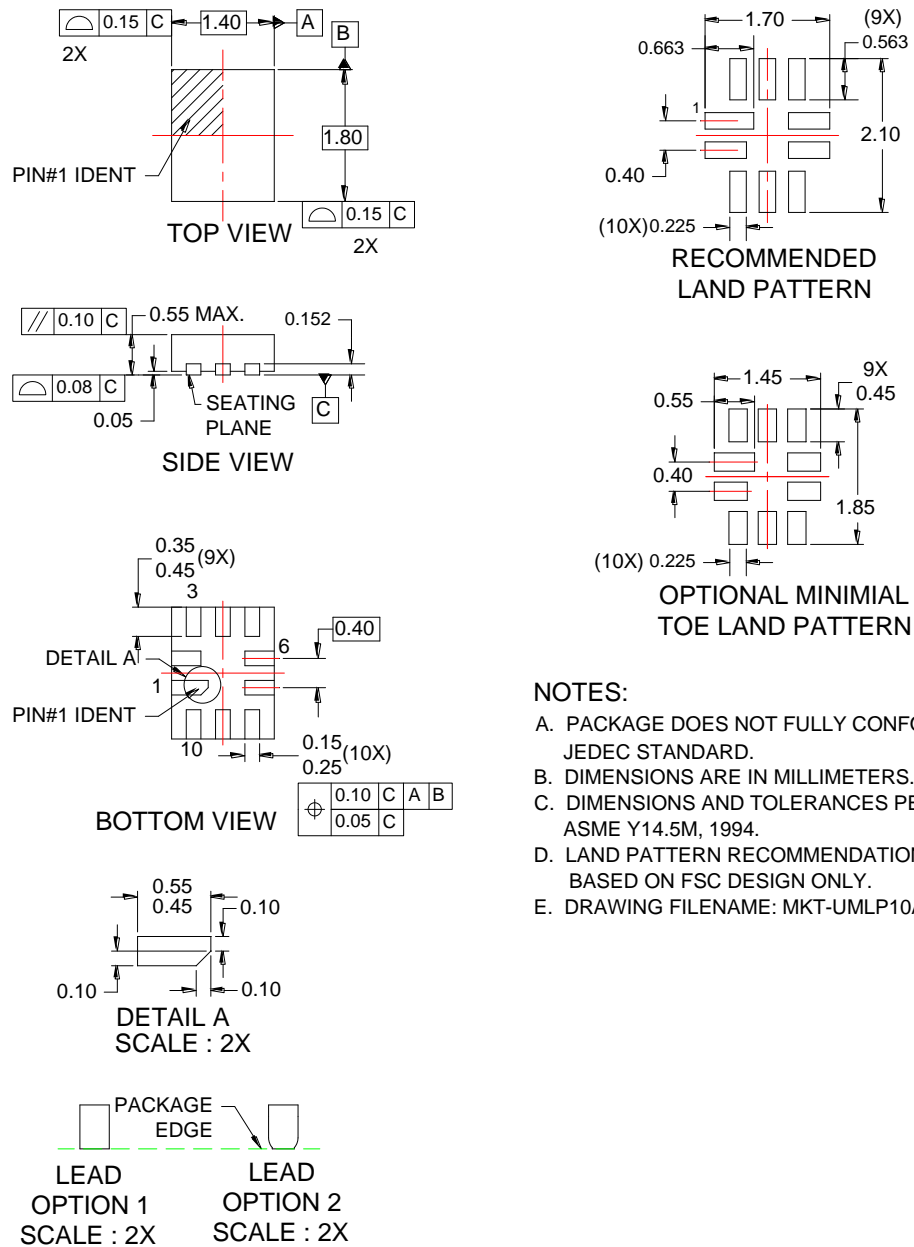

Figure 27. 10-Lead Quad, Ultrathin MLP, 1.4 x 1.8mm





Package drawings are provided as a service to customers considering Fairchild components. Drawings may change in any manner without notice. Please note the revision and/or date on the drawing and contact a Fairchild Semiconductor representative to verify or obtain the most recent revision. Package specifications do not expand the terms of Fairchild's worldwide terms and conditions, specifically the warranty therein, which covers Fairchild products.

Always visit Fairchild Semiconductor's online packaging area for the most recent package drawings:
<http://www.fairchildsemi.com/packaging/>.



TRADEMARKS

The following includes registered and unregistered trademarks and service marks, owned by Fairchild Semiconductor and/or its global subsidiaries, and is not intended to be an exhaustive list of all such trademarks.

- | | | | |
|---|--|---|---|
| 2Cool™ | F-PFS™ | PowerTrench® | The Power Franchise® |
| AccuPower™ | FRFET® | PowerXS™ | the power franchise |
| AX-CAP™* | Global Power Resource™ | Programmable Active Droop™ | TinyBoost™ |
| BitSiC™ | GreenBridge™ | QFET® | TinyBuck™ |
| Build it Now™ | Green FPS™ | QS™ | TinyCalc™ |
| CorePLUS™ | Green FPS™ e-Series™ | Quiet Series™ | TinyLogic® |
| CorePOWER™ | Gmax™ | RapidConfigure™ | TINYOPTO™ |
| CROSSVOLT™ | GTO™ |  | TinyPower™ |
| CTL™ | IntelliMAX™ | Saving our world, 1mW/WkW at a time™ | TinyPWM™ |
| Current Transfer Logic™ | ISOPLANAR™ | SignalWise™ | TinyWire™ |
| DEUXPEED® | Making Small Speakers Sound Louder and Better™ | SmartMax™ | TranSiC™ |
| Dual Cool™ | MegaBuck™ | SMART START™ | TriFault Detect™ |
| EcoSPARK® | MICROCOUPLER™ | Solutions for Your Success™ | TRUECURRENT®* |
| EfficientMax™ | MicroFET™ | SPM® | µSerDes™ |
| ESBC™ | MicroPak™ | STEALTH™ |  |
|  | MicroPak2™ | SuperFET® | UHC® |
| Fairchild® | MillerDrive™ | SuperSOT™-3 | Ultra FRFET™ |
| Fairchild Semiconductor® | MotionMax™ | SupersOT™-6 | UniFET™ |
| FACT Quiet Series™ | Motion-SPM™ | SuperSOT™-8 | VCX™ |
| FACT® | mWSaver™ | SupreMOS® | VisualMax™ |
| FAST® | OptoHiT™ | SyncFET™ | VoltagePlus™ |
| FastvCore™ | OPTOLOGIC® | Sync-Lock™ | XS™ |
| FETBench™ | OPTOPLANAR® |  | |
| FlashWriter®* | | | |
| FPS™ | | | |

* Trademarks of System General Corporation, used under license by Fairchild Semiconductor.

DISCLAIMER

FAIRCHILD SEMICONDUCTOR RESERVES THE RIGHT TO MAKE CHANGES WITHOUT FURTHER NOTICE TO ANY PRODUCTS HEREIN TO IMPROVE RELIABILITY, FUNCTION, OR DESIGN. FAIRCHILD DOES NOT ASSUME ANY LIABILITY ARISING OUT OF THE APPLICATION OR USE OF ANY PRODUCT OR CIRCUIT DESCRIBED HEREIN; NEITHER DOES IT CONVEY ANY LICENSE UNDER ITS PATENT RIGHTS, NOR THE RIGHTS OF OTHERS. THESE SPECIFICATIONS DO NOT EXPAND THE TERMS OF FAIRCHILD'S WORLDWIDE TERMS AND CONDITIONS, SPECIFICALLY THE WARRANTY THEREIN, WHICH COVERS THESE PRODUCTS.

LIFE SUPPORT POLICY

FAIRCHILD'S PRODUCTS ARE NOT AUTHORIZED FOR USE AS CRITICAL COMPONENTS IN LIFE SUPPORT DEVICES OR SYSTEMS WITHOUT THE EXPRESS WRITTEN APPROVAL OF FAIRCHILD SEMICONDUCTOR CORPORATION.

As used herein:

1. Life support devices or systems are devices or systems which, (a) are intended for surgical implant into the body or (b) support or sustain life, and (c) whose failure to perform when properly used in accordance with instructions for use provided in the labeling, can be reasonably expected to result in a significant injury of the user.
2. A critical component in any component of a life support, device, or system whose failure to perform can be reasonably expected to cause the failure of the life support device or system, or to affect its safety or effectiveness.

ANTI-COUNTERFEITING POLICY

Fairchild Semiconductor Corporation's Anti-Counterfeiting Policy. Fairchild's Anti-Counterfeiting Policy is also stated on our external website, www.fairchildsemi.com, under Sales Support.

Counterfeiting of semiconductor parts is a growing problem in the industry. All manufacturers of semiconductor products are experiencing counterfeiting of their parts. Customers who inadvertently purchase counterfeit parts experience many problems such as loss of brand reputation, substandard performance, failed applications, and increased cost of production and manufacturing delays. Fairchild is taking strong measures to protect ourselves and our customers from the proliferation of counterfeit parts. Fairchild strongly encourages customers to purchase Fairchild parts either directly from Fairchild or from Authorized Fairchild Distributors who are listed by country on our web page cited above. Products customers buy either from Fairchild directly or from Authorized Fairchild Distributors are genuine parts, have full traceability, meet Fairchild's quality standards for handling and storage and provide access to Fairchild's full range of up-to-date technical and product information. Fairchild and our Authorized Distributors will stand behind all warranties and will appropriately address any warranty issues that may arise. Fairchild will not provide any warranty coverage or other assistance for parts bought from Unauthorized Sources. Fairchild is committed to combat this global problem and encourage our customers to do their part in stopping this practice by buying direct or from authorized distributors.

PRODUCT STATUS DEFINITIONS

Definition of Terms

Datasheet Identification	Product Status	Definition
Advance Information	Formative / In Design	Datasheet contains the design specifications for product development. Specifications may change in any manner without notice.
Preliminary	First Production	Datasheet contains preliminary data; supplementary data will be published at a later date. Fairchild Semiconductor reserves the right to make changes at any time without notice to improve design.
No Identification Needed	Full Production	Datasheet contains final specifications. Fairchild Semiconductor reserves the right to make changes at any time without notice to improve the design.
Obsolete	Not In Production	Datasheet contains specifications on a product that is discontinued by Fairchild Semiconductor. The datasheet is for reference information only.

Rev. I61

ON Semiconductor and  are trademarks of Semiconductor Components Industries, LLC dba ON Semiconductor or its subsidiaries in the United States and/or other countries. ON Semiconductor owns the rights to a number of patents, trademarks, copyrights, trade secrets, and other intellectual property. A listing of ON Semiconductor's product/patent coverage may be accessed at www.onsemi.com/site/pdf/Patent-Marking.pdf. ON Semiconductor reserves the right to make changes without further notice to any products herein. ON Semiconductor makes no warranty, representation or guarantee regarding the suitability of its products for any particular purpose, nor does ON Semiconductor assume any liability arising out of the application or use of any product or circuit, and specifically disclaims any and all liability, including without limitation special, consequential or incidental damages. Buyer is responsible for its products and applications using ON Semiconductor products, including compliance with all laws, regulations and safety requirements or standards, regardless of any support or applications information provided by ON Semiconductor. "Typical" parameters which may be provided in ON Semiconductor data sheets and/or specifications can and do vary in different applications and actual performance may vary over time. All operating parameters, including "Typicals" must be validated for each customer application by customer's technical experts. ON Semiconductor does not convey any license under its patent rights nor the rights of others. ON Semiconductor products are not designed, intended, or authorized for use as a critical component in life support systems or any FDA Class 3 medical devices or medical devices with a same or similar classification in a foreign jurisdiction or any devices intended for implantation in the human body. Should Buyer purchase or use ON Semiconductor products for any such unintended or unauthorized application, Buyer shall indemnify and hold ON Semiconductor and its officers, employees, subsidiaries, affiliates, and distributors harmless against all claims, costs, damages, and expenses, and reasonable attorney fees arising out of, directly or indirectly, any claim of personal injury or death associated with such unintended or unauthorized use, even if such claim alleges that ON Semiconductor was negligent regarding the design or manufacture of the part. ON Semiconductor is an Equal Opportunity/Affirmative Action Employer. This literature is subject to all applicable copyright laws and is not for resale in any manner.

PUBLICATION ORDERING INFORMATION

LITERATURE FULFILLMENT:

Literature Distribution Center for ON Semiconductor
19521 E. 32nd Pkwy, Aurora, Colorado 80011 USA
Phone: 303-675-2175 or 800-344-3860 Toll Free USA/Canada
Fax: 303-675-2176 or 800-344-3867 Toll Free USA/Canada
Email: orderlit@onsemi.com

N. American Technical Support: 800-282-9855 Toll Free
USA/Canada
Europe, Middle East and Africa Technical Support:
Phone: 421 33 790 2910
Japan Customer Focus Center
Phone: 81-3-5817-1050

ON Semiconductor Website: www.onsemi.com
Order Literature: <http://www.onsemi.com/orderlit>
For additional information, please contact your local
Sales Representative

Mouser Electronics

Authorized Distributor

Click to View Pricing, Inventory, Delivery & Lifecycle Information:

[ON Semiconductor:](#)

[FSA221L10X](#) [FSA221MUX](#) [FSA221UMX](#)

Компания «Океан Электроники» предлагает заключение долгосрочных отношений при поставках импортных электронных компонентов на взаимовыгодных условиях!

Наши преимущества:

- Поставка оригинальных импортных электронных компонентов напрямую с производств Америки, Европы и Азии, а так же с крупнейших складов мира;
- Широкая линейка поставок активных и пассивных импортных электронных компонентов (более 30 млн. наименований);
- Поставка сложных, дефицитных, либо снятых с производства позиций;
- Оперативные сроки поставки под заказ (от 5 рабочих дней);
- Экспресс доставка в любую точку России;
- Помощь Конструкторского Отдела и консультации квалифицированных инженеров;
- Техническая поддержка проекта, помощь в подборе аналогов, поставка прототипов;
- Поставка электронных компонентов под контролем ВП;
- Система менеджмента качества сертифицирована по Международному стандарту ISO 9001;
- При необходимости вся продукция военного и аэрокосмического назначения проходит испытания и сертификацию в лаборатории (по согласованию с заказчиком);
- Поставка специализированных компонентов военного и аэрокосмического уровня качества (Xilinx, Altera, Analog Devices, Intersil, Interpoint, Microsemi, Actel, Aeroflex, Peregrine, VPT, Syfer, Eurofarad, Texas Instruments, MS Kennedy, Miteq, Cobham, E2V, MA-COM, Hittite, Mini-Circuits, General Dynamics и др.);

Компания «Океан Электроники» является официальным дистрибьютором и эксклюзивным представителем в России одного из крупнейших производителей разъемов военного и аэрокосмического назначения «JONHON», а так же официальным дистрибьютором и эксклюзивным представителем в России производителя высокотехнологичных и надежных решений для передачи СВЧ сигналов «FORSTAR».



JONHON

«JONHON» (основан в 1970 г.)

Разъемы специального, военного и аэрокосмического назначения:

(Применяются в военной, авиационной, аэрокосмической, морской, железнодорожной, горно- и нефтедобывающей отраслях промышленности)

«FORSTAR» (основан в 1998 г.)

ВЧ соединители, коаксиальные кабели, кабельные сборки и микроволновые компоненты:

(Применяются в телекоммуникациях гражданского и специального назначения, в средствах связи, РЛС, а так же военной, авиационной и аэрокосмической отраслях промышленности).



Телефон: 8 (812) 309-75-97 (многоканальный)

Факс: 8 (812) 320-03-32

Электронная почта: ocean@oceanchips.ru

Web: <http://oceanchips.ru/>

Адрес: 198099, г. Санкт-Петербург, ул. Калинина, д. 2, корп. 4, лит. А