



SANYO Semiconductors

DATA SHEET

An ON Semiconductor Company

LV8413GP — Bi-CMOS LSI For DSC, and Cell Phone Camera Modules H-Bridge × 2-channel Motor Driver

Overview

The LV8413GP is an H-bridge × 2-channel motor driver IC and is able to control 4 modes of forward, reverse, brake, and standby.

This IC housed in a miniature package is optimum for use in a stepping motor driving system for DSC or a camera module of cell phones.

Features

- Saturation drive H-bridge : 2-channels
- Built-in thermal protection circuit
- Built-in low voltage malfunction prevention circuit
- Incorporates a transistor for driving photosensors

Specifications

Absolute Maximum Ratings at $T_a = 25^\circ\text{C}$

Parameter	Symbol	Conditions	Ratings	Unit
Power supply voltage 1	V_M max		6	V
Power supply voltage 2	V_{CC} max		6	V
Output peak current	I_O peak	Outs 1 to 4, $t \leq 10\text{msec}$, ON-duty $\leq 20\%$	600	mA
Output continuous current 1	I_O max1	Outs 1 to 4	400	mA
Output continuous current 2	I_O max2	PI	15	mA
Allowable power dissipation	P_d max	Mounted on a circuit board*	0.7	W
Operating temperature	T_{opr}		-30 to +85	$^\circ\text{C}$
Storage temperature	T_{stg}		-55 to +150	$^\circ\text{C}$

* Specified circuit board : 50.0mm × 40.0mm × 0.8mm : glass epoxy four-layer board (2S2P)

■ Any and all SANYO Semiconductor Co.,Ltd. products described or contained herein are, with regard to "standard application", intended for the use as general electronics equipment (home appliances, AV equipment, communication device, office equipment, industrial equipment etc.). The products mentioned herein shall not be intended for use for any "special application" (medical equipment whose purpose is to sustain life, aerospace instrument, nuclear control device, burning appliances, transportation machine, traffic signal system, safety equipment etc.) that shall require extremely high level of reliability and can directly threaten human lives in case of failure or malfunction of the product or may cause harm to human bodies, nor shall they grant any guarantee thereof. If you should intend to use our products for applications outside the standard applications of our customer who is considering such use and/or outside the scope of our intended standard applications, please consult with us prior to the intended use. If there is no consultation or inquiry before the intended use, our customer shall be solely responsible for the use.

■ Specifications of any and all SANYO Semiconductor Co.,Ltd. products described or contained herein stipulate the performance, characteristics, and functions of the described products in the independent state, and are not guarantees of the performance, characteristics, and functions of the described products as mounted in the customer's products or equipment. To verify symptoms and states that cannot be evaluated in an independent device, the customer should always evaluate and test devices mounted in the customer's products or equipment.

SANYO Semiconductor Co., Ltd.

<http://semicon.sanyo.com/en/network>

LV8413GP

Recommended Operating Conditions at Ta = 25°C

Parameter	Symbol	Conditions	Ratings	Unit
Power supply voltage range 1	VM		2.5 to 5.5	V
Power supply voltage range 2	VCC		2.5 to 5.5	V
Logic input voltage range	V _{IN}		0 to V _{CC} +0.3	V
Input frequency	f _{IN}	IN1 to 4, INA	to 100	kHz

Electrical Characteristics at Ta = 25°C, VM = 5V, VCC = 3.3V, unless otherwise specified.

Parameter	Symbol	Conditions	Ratings			Unit
			min	typ	max	
Standby mode current drain	I _{stn}	IN1 to 4 = "L"			1.0	μA
VM current drain	IM	Any one of IN1 to 4 = "H", with no load		70	150	μA
VCC current drain	I _{CC}	Any one of IN1 to 4 = "H"		0.6	1.2	mA
VCC low-voltage cutoff voltage	V _{th} V _{CC}		1.85	2.10	2.35	V
Low-voltage hysteresis voltage	V _{th} HYS		100	150	200	mV
Thermal shutdown temperature	TSD	Design guarantee value *	160	180	200	°C
Thermal hysteresis width	ΔTSD	Design guarantee value *	10	30	50	°C
OUT1 to 4						
Logic pin internal pull-down resistance	R _{in}	IN1 to 4	50	100	200	kΩ
Logic pin input current	I _{inL}	V _{IN} = 0, IN1 to 4			1.0	μA
	I _{inH}	V _{IN} = 3.3V, IN1 to 4	20	33	60	μA
Logic input high-level voltage	V _{inH}	IN1 to 4	2.5			V
Logic input low-level voltage	V _{inL}	IN1 to 4			1.0	V
Output on-resistance	R _{onU}	I _O = 400mA, upper ON resistance		0.5	0.8	Ω
	R _{onD}	I _O = 400mA, lower ON resistance		0.3	0.5	Ω
Output leakage current	I _{Oleak}				1	μA
Diode forward voltage	VD	ID = -400mA		1.0		V
PI						
Logic pin internal pull-down resistance	R _{in}	INA	50	100	200	kΩ
Logic pin input current	I _{inL}	V _{IN} = 0, INA			1.0	μA
	I _{inH}	V _{IN} = 3.3V, INA	20	33	50	μA
Logic input high-level voltage	V _{inH}	INA	2.5			V
Logic input low-level voltage	V _{inL}	INA			1.0	V
Output on-resistance	R _{on}	I _O = 10mA		4	6	Ω
Output leakage current	I _{Oleak}				1	μA

LV8413GP

Package Dimensions

unit : mm (typ)
3318

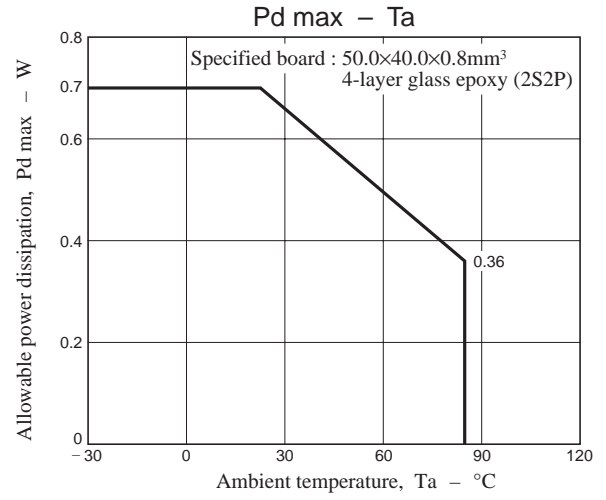
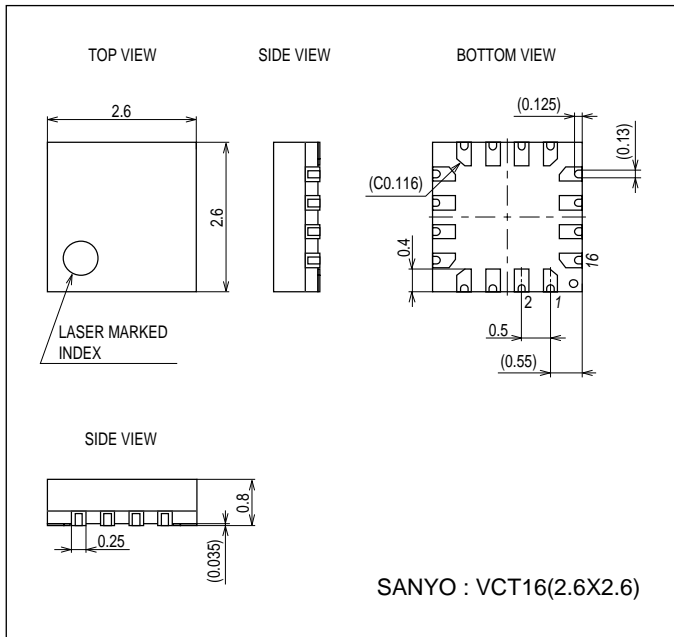

Pin Assignment

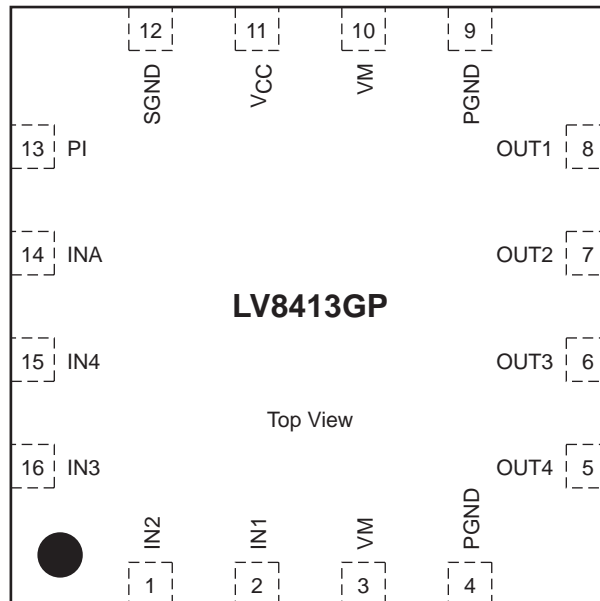

LV8413GP

Block Diagram

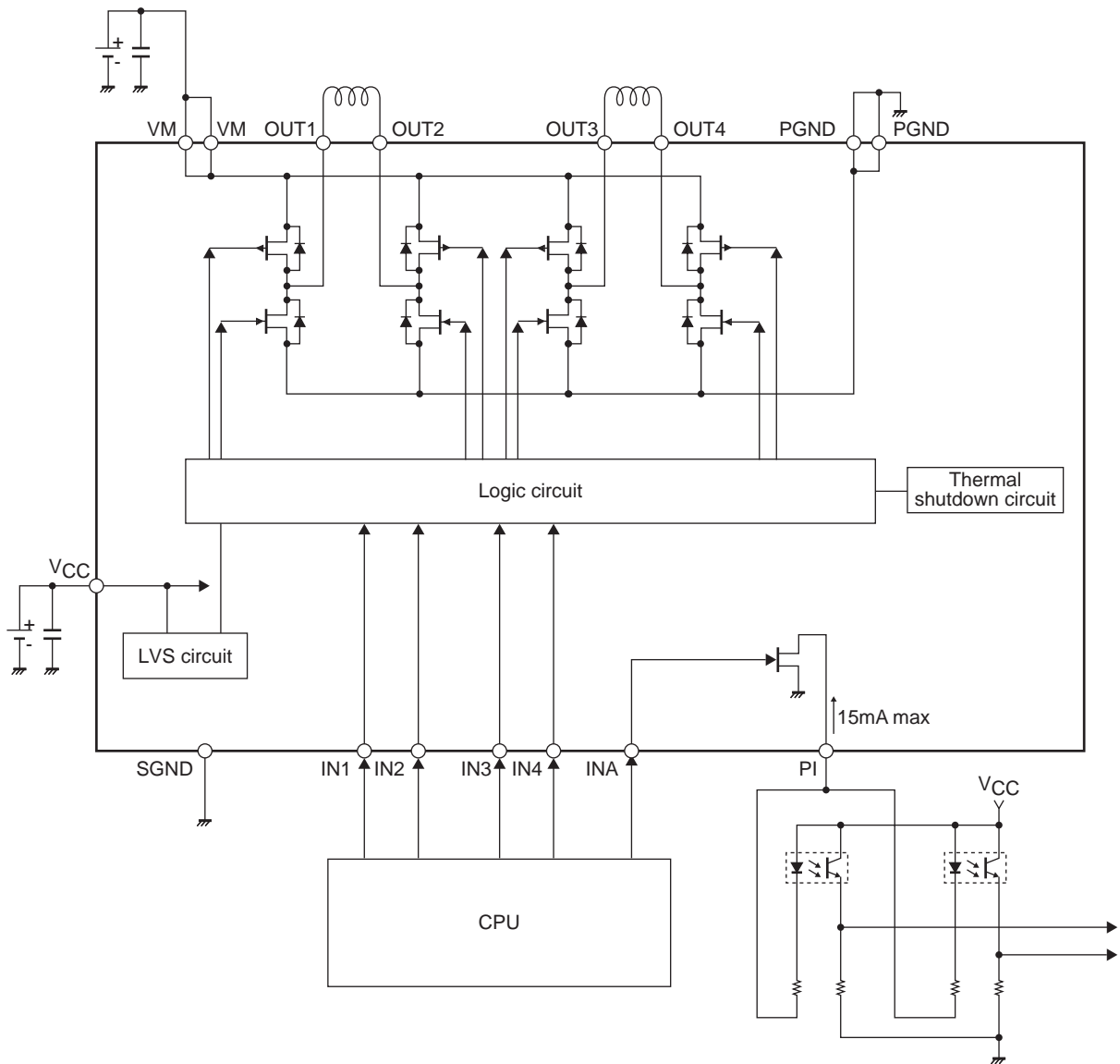

LV8413GP

Pin Functions

Pin No.	Pin name	Pin Function	Equivalent Circuit
2 1 16 15 14	IN1 IN2 IN3 IN4 INA	Control signal input pin Control signal input pin Control signal input pin Control signal input pin Control signal input pin	
8 7 6 5	OUT1 OUT2 OUT3 OUT4	Outpin Outpin Outpin Outpin	
13	PI	Outpin	
11	VCC	Logic system power supply connection pin	
3 10	VM VM	Motor power supply connection pin Motor power supply connection pin	
12	SGND	Signal ground	
4 9	PGND PGND	Power ground Power ground	

Logic input specifications

- Common channels 1 to 2
 ch1 : IN1 to IN2, OUT1 to OUT2
 ch2 : IN3 to IN4, OUT3 to OUT4

Input		Output		Operation mode
IN1	IN2	OUT1	OUT2	
L	L	OFF	OFF	Standby
H	L	H	L	CW (forward)
L	H	L	H	CCW (reverse)
H	H	L	L	Brake

- Output stage transistor function

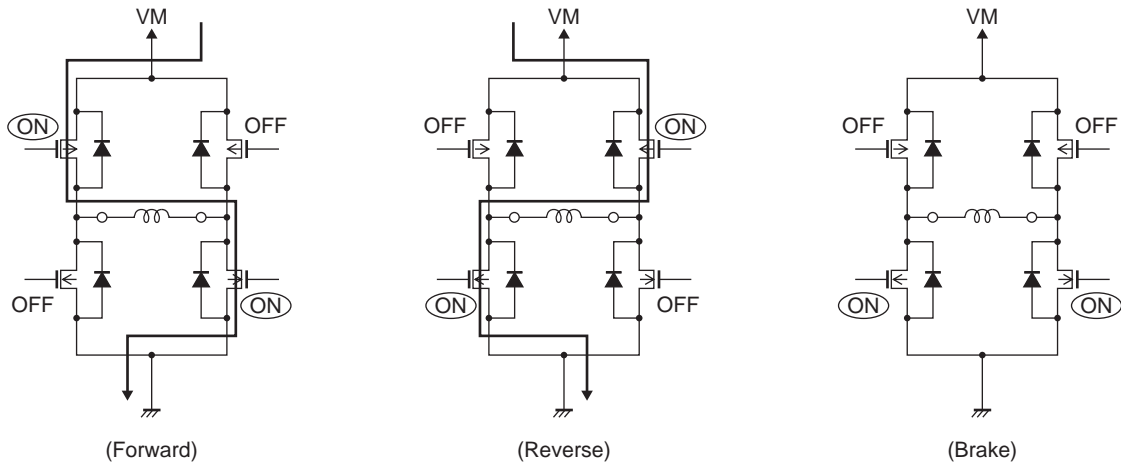

- Photo sensor driving transistor

When thermal shutdown and VCC low-voltage cut circuits are activated, OUT1 through OUT4 are turned OFF under control of the internal circuit. But the output (PI) of photo sensor driving transistor continues operation.

Input INA	Photo sensor driving PI
L	OFF
H	ON

- SANYO Semiconductor Co.,Ltd. assumes no responsibility for equipment failures that result from using products at values that exceed, even momentarily, rated values (such as maximum ratings, operating condition ranges, or other parameters) listed in products specifications of any and all SANYO Semiconductor Co.,Ltd. products described or contained herein.
- Regarding monolithic semiconductors, if you should intend to use this IC continuously under high temperature, high current, high voltage, or drastic temperature change, even if it is used within the range of absolute maximum ratings or operating conditions, there is a possibility of decrease reliability. Please contact us for a confirmation.
- SANYO Semiconductor Co.,Ltd. strives to supply high-quality high-reliability products, however, any and all semiconductor products fail or malfunction with some probability. It is possible that these probabilistic failures or malfunction could give rise to accidents or events that could endanger human lives, trouble that could give rise to smoke or fire, or accidents that could cause damage to other property. When designing equipment, adopt safety measures so that these kinds of accidents or events cannot occur. Such measures include but are not limited to protective circuits and error prevention circuits for safe design, redundant design, and structural design.
- In the event that any or all SANYO Semiconductor Co.,Ltd. products described or contained herein are controlled under any of applicable local export control laws and regulations, such products may require the export license from the authorities concerned in accordance with the above law.
- No part of this publication may be reproduced or transmitted in any form or by any means, electronic or mechanical, including photocopying and recording, or any information storage or retrieval system, or otherwise, without the prior written consent of SANYO Semiconductor Co.,Ltd.
- Any and all information described or contained herein are subject to change without notice due to product/technology improvement, etc. When designing equipment, refer to the "Delivery Specification" for the SANYO Semiconductor Co.,Ltd. product that you intend to use.
- Upon using the technical information or products described herein, neither warranty nor license shall be granted with regard to intellectual property rights or any other rights of SANYO Semiconductor Co.,Ltd. or any third party. SANYO Semiconductor Co.,Ltd. shall not be liable for any claim or suits with regard to a third party's intellectual property rights which has resulted from the use of the technical information and products mentioned above.

This catalog provides information as of Jun, 2011. Specifications and information herein are subject to change without notice.

Компания «Океан Электроники» предлагает заключение долгосрочных отношений при поставках импортных электронных компонентов на взаимовыгодных условиях!

Наши преимущества:

- Поставка оригинальных импортных электронных компонентов напрямую с производств Америки, Европы и Азии, а так же с крупнейших складов мира;
- Широкая линейка поставок активных и пассивных импортных электронных компонентов (более 30 млн. наименований);
- Поставка сложных, дефицитных, либо снятых с производства позиций;
- Оперативные сроки поставки под заказ (от 5 рабочих дней);
- Экспресс доставка в любую точку России;
- Помощь Конструкторского Отдела и консультации квалифицированных инженеров;
- Техническая поддержка проекта, помощь в подборе аналогов, поставка прототипов;
- Поставка электронных компонентов под контролем ВП;
- Система менеджмента качества сертифицирована по Международному стандарту ISO 9001;
- При необходимости вся продукция военного и аэрокосмического назначения проходит испытания и сертификацию в лаборатории (по согласованию с заказчиком);
- Поставка специализированных компонентов военного и аэрокосмического уровня качества (Xilinx, Altera, Analog Devices, Intersil, Interpoint, Microsemi, Actel, Aeroflex, Peregrine, VPT, Syfer, Eurofarad, Texas Instruments, MS Kennedy, Miteq, Cobham, E2V, MA-COM, Hittite, Mini-Circuits, General Dynamics и др.);

Компания «Океан Электроники» является официальным дистрибьютором и эксклюзивным представителем в России одного из крупнейших производителей разъемов военного и аэрокосмического назначения «JONHON», а так же официальным дистрибьютором и эксклюзивным представителем в России производителя высокотехнологичных и надежных решений для передачи СВЧ сигналов «FORSTAR».



JONHON

«JONHON» (основан в 1970 г.)

Разъемы специального, военного и аэрокосмического назначения:

(Применяются в военной, авиационной, аэрокосмической, морской, железнодорожной, горно- и нефтедобывающей отраслях промышленности)

«FORSTAR» (основан в 1998 г.)

ВЧ соединители, коаксиальные кабели, кабельные сборки и микроволновые компоненты:

(Применяются в телекоммуникациях гражданского и специального назначения, в средствах связи, РЛС, а так же военной, авиационной и аэрокосмической отраслях промышленности).



Телефон: 8 (812) 309-75-97 (многоканальный)

Факс: 8 (812) 320-03-32

Электронная почта: ocean@oceanchips.ru

Web: <http://oceanchips.ru/>

Адрес: 198099, г. Санкт-Петербург, ул. Калинина, д. 2, корп. 4, лит. А