

LITIX™ Basic

TLD1315EL

3 Channel High-Side Current Source



Package	PG-SSOP-14
Marking	TLD1315

1 Overview

Applications

- Exterior LED lighting applications such as tail/brake light, turn indicator, position light, side marker,...
- Interior LED lighting applications such as ambient lighting, interior illumination and dash board lighting.

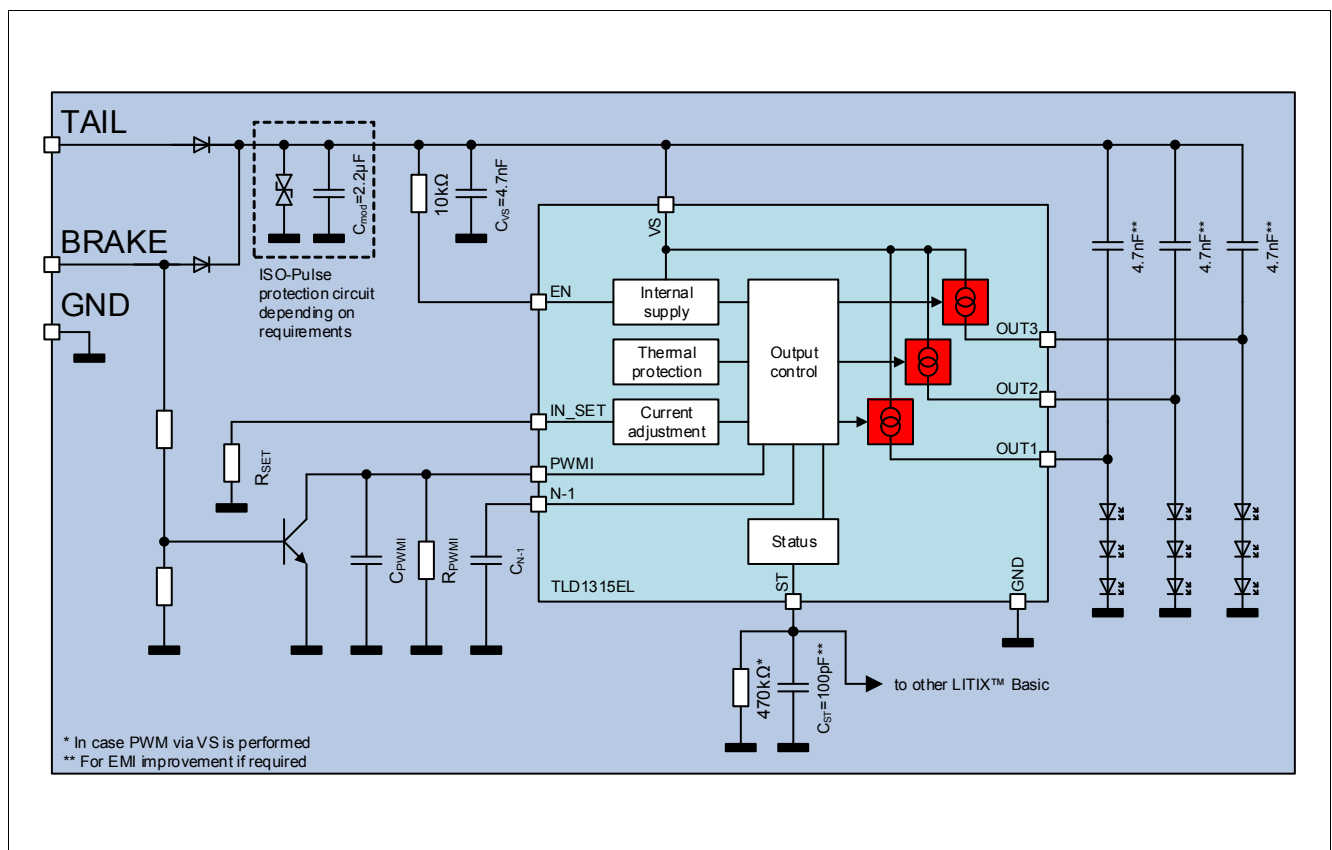
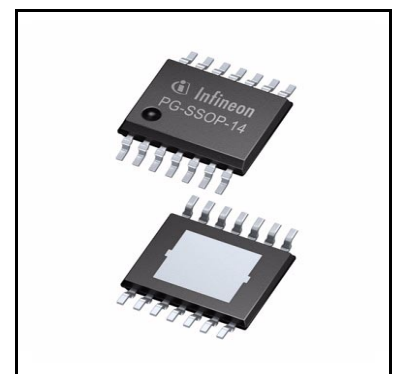

Application Diagram with TLD1315EL

Overview

Basic Features

- 3 Channel device with integrated output stages (current sources), optimized to drive LEDs with output current up to 120 mA per channel
- Low current consumption in sleep mode
- PWM-operation supported via VS- and EN-pin
- Integrated PWM dimming engine to provide two LED brightness levels without external logic (e.g. μC)
- Output current adjustable via external low power resistor and possibility to connect PTC resistor for LED protection during over temperature conditions
- Reverse polarity protection and overload protection
- Undervoltage detection
- N-1 detection, latched function
- Wide temperature range: $-40^\circ\text{C} < T_j < 150^\circ\text{C}$
- PG-SSOP-14 package with exposed heatslug

Description

The LITIX™ Basic TLD1315EL is a three channel high side driver IC with integrated output stages. It is designed to control LEDs with a current up to 120 mA. In typical automotive applications the device is capable to drive i.e. 3 red LEDs per chain (total 9 LEDs) with a current up to 60 mA, which is limited by thermal cooling aspects. The output current is controlled practically independent of load and supply voltage changes.

Table 1 Product Summary

Parameter	Symbol	Value
Operating voltage range	$V_{S(\text{nom})}$	5.5 V ... 40 V
Maximum voltage	$V_{S(\text{max})}$ $V_{\text{OUTx}(\text{max})}$	40 V
Nominal output (load) current	$I_{\text{OUTx}(\text{nom})}$	60 mA when using a supply voltage range of 8 V - 18 V (e.g. Automotive car battery). Currents up to $I_{\text{OUT}(\text{max})}$ possible in applications with low thermal resistance R_{thJA}
Maximum output (load) current	$I_{\text{OUTx}(\text{max})}$	120 mA; depending on thermal resistance R_{thJA}
Output current accuracy at $R_{\text{SET}} = 12 \text{ k}\Omega$	k_{LT}	$750 \pm 7\%$
Current consumption in sleep mode	$I_{S(\text{sleep,typ})}$	0.1 μA

Protective Functions

- ESD protection
- Under voltage lock out
- Over Load protection
- Over Temperature protection
- Reverse Polarity protection

Diagnostic Functions

- N-1 detection, latched function
- SC to Vs (indicated by N-1 diagnosis)

Block Diagram

2 Block Diagram

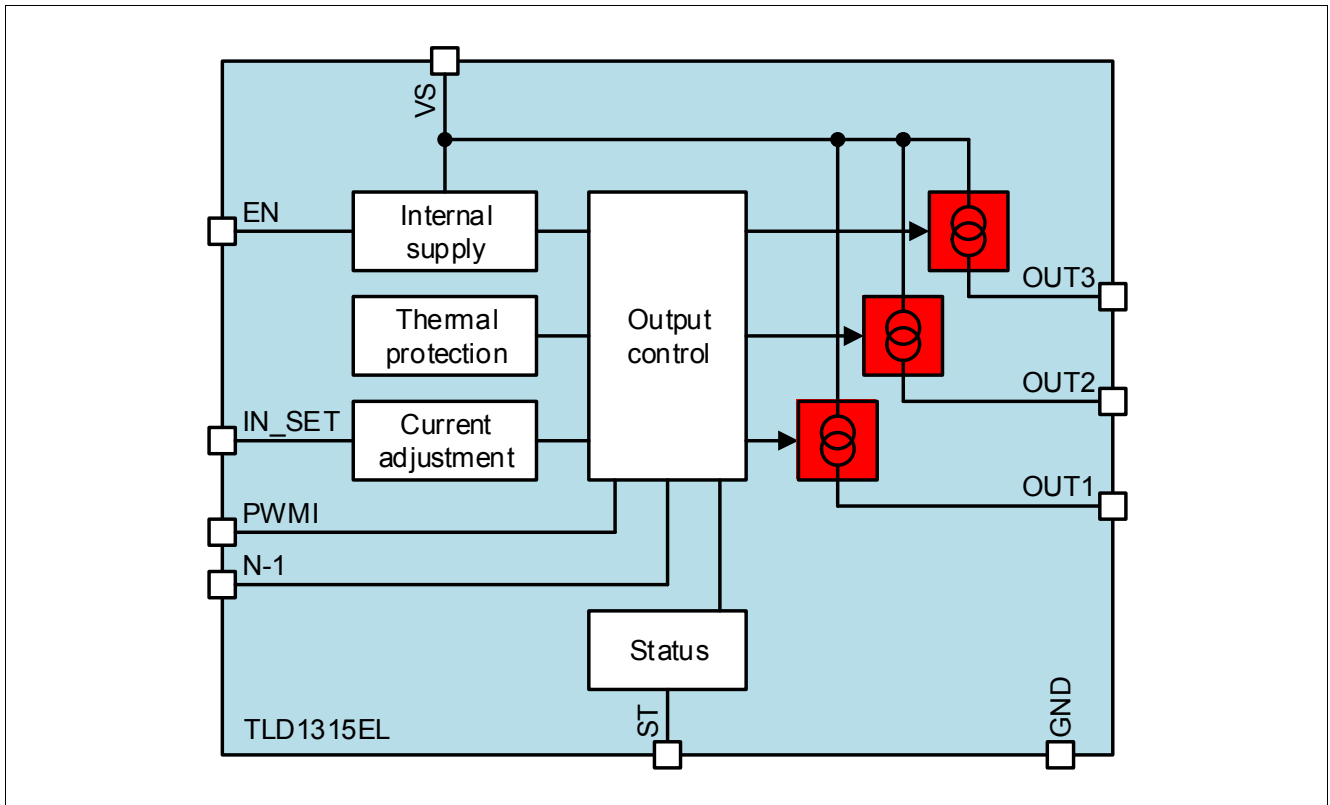

Figure 1 Basic Block Diagram

Pin Configuration

3 Pin Configuration

3.1 Pin Assignment

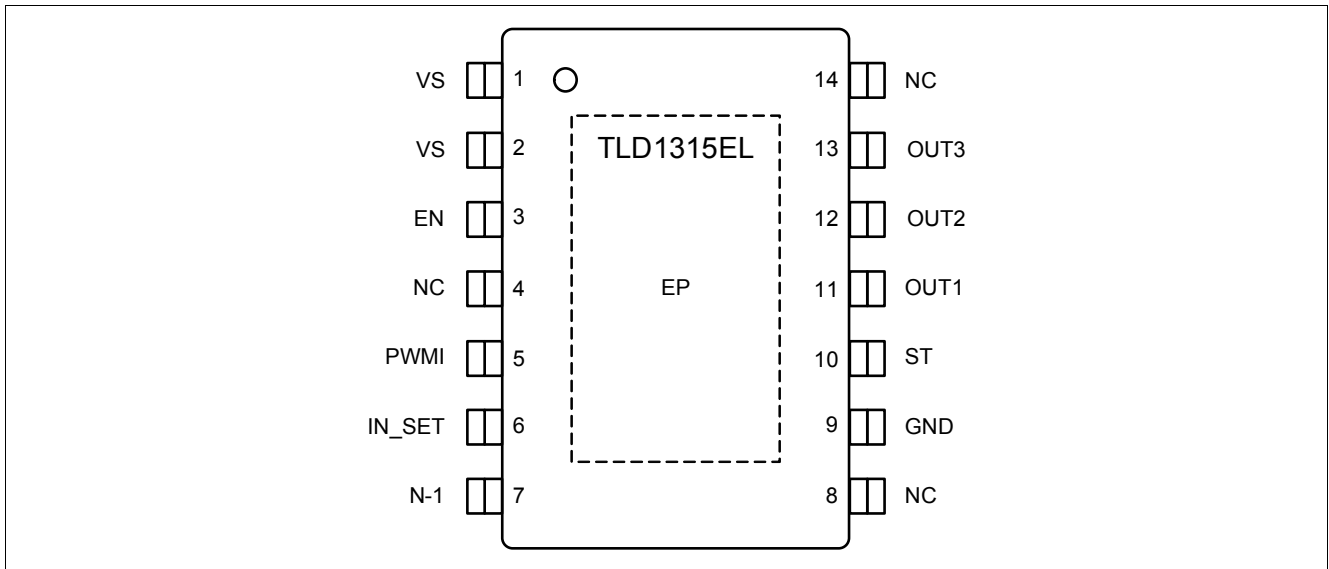

Figure 2 Pin Configuration

Pin Configuration

3.2 Pin Definitions and Functions

Pin	Symbol	Input/ Output	Function
1, 2	VS	–	Supply Voltage; battery supply, connect a decoupling capacitor (100 nF - 1 μF) to GND
3	EN	I	Enable pin
4	NC	–	Pin not connected
5	PWMI	I/O	PWM Input
6	IN_SET	I/O	Input / SET pin; Connect a low power resistor to adjust the output current
7	N-1	I/O	N-1 pin
8	NC	–	Pin not connected
9	GND	–	¹⁾ Ground
10	ST	I/O	Status pin
11	OUT1	O	Output 1
12	OUT2	O	Output 2
13	OUT3	O	Output 3
14	NC	–	Pin not connected
Exposed Pad	GND	–	¹⁾ Exposed Pad; connect to GND in application

1) Connect all GND-pins together.

General Product Characteristics

4 General Product Characteristics

4.1 Absolute Maximum Ratings

Absolute Maximum Ratings ¹⁾

$T_j = -40^\circ\text{C}$ to $+150^\circ\text{C}$; all voltages with respect to ground, positive current flowing into pin for input pins (I), positive currents flowing out of the I/O and output pins (O) (unless otherwise specified)

Pos.	Parameter	Symbol	Limit Values		Unit	Conditions
			Min.	Max.		
Voltages						
4.1.1	Supply voltage	V_S	-16	40	V	-
4.1.2	Input voltage EN	V_{EN}	-16	40	V	-
4.1.3	Input voltage EN related to V_S	$V_{EN(VS)}$	$V_S - 40$	$V_S + 16$	V	-
4.1.4	Input voltage EN related to V_{OUTx}	$V_{EN} - V_{OUTx}$	-16	40	V	-
4.1.5	Output voltage	V_{OUTx}	-1	40	V	-
4.1.6	Power stage voltage	$V_{PS} = V_S - V_{OUTx}$	-16	40	V	-
4.1.7	Input voltage PWMI	V_{PWMI}	-0.3	6	V	-
4.1.8	IN_SET voltage	V_{IN_SET}	-0.3	6	V	-
4.1.9	N-1 voltage	V_{N-1}	-0.3	6	V	-
4.1.10	Status voltage	V_{ST}	-0.3	6	V	-
Currents						
4.1.11	IN_SET current	I_{IN_SET}	-	2 8	mA	- Diagnosis output
4.1.12	N-1 current	I_{N-1}	-0.5	0.5	mA	-
4.1.13	Output current	I_{OUTx}	-	130	mA	-
Temperatures						
4.1.14	Junction temperature	T_j	-40	150	°C	-
4.1.15	Storage temperature	T_{stg}	-55	150	°C	-
ESD Susceptibility						
4.1.16	ESD resistivity to GND	V_{ESD}	-2	2	kV	Human Body Model (100 pF via $1.5\text{ k}\Omega$) ²⁾
4.1.17	ESD resistivity all pins to GND	V_{ESD}	-500	500	V	CDM ³⁾
4.1.18	ESD resistivity corner pins to GND	V_{ESD}	-750	750	V	CDM ³⁾

1) Not subject to production test, specified by design

2) ESD susceptibility, Human Body Model "HBM" according to ANSI/ESDA/JEDEC JS-001-2011

3) ESD susceptibility, Charged Device Model "CDM" according to JESD22-C101E

Note: Stresses above the ones listed here may cause permanent damage to the device. Exposure to absolute maximum rating conditions for extended periods may affect device reliability.

General Product Characteristics

Note: Integrated protection functions are designed to prevent IC destruction under fault conditions described in the data sheet. Fault conditions are considered as “outside” normal operating range. Protection functions are not designed for continuous repetitive operation.

4.2 Functional Range

Pos.	Parameter	Symbol	Limit Values		Unit	Conditions
			Min.	Max.		
4.2.19	Supply voltage range for normal operation	$V_{S(nom)}$	5.5	40	V	–
4.2.20	Power on reset threshold	$V_{S(POR)}$	–	5	V	$V_{EN} = V_S$ $R_{SET} = 12 \text{ k}\Omega$ $I_{OUTx} = 80\% I_{OUTx(nom)}$ $V_{OUTx} = 2.5 \text{ V}$
4.2.21	Junction temperature	T_j	-40	150	°C	–

Note: Within the functional range the IC operates as described in the circuit description. The electrical characteristics are specified within the conditions given in the related electrical characteristics table.

4.3 Thermal Resistance

Pos.	Parameter	Symbol	Limit Values			Unit	Conditions
			Min.	Typ.	Max.		
4.3.1	Junction to Case	R_{thJC}	–	8	10	K/W	1) 2)
4.3.2	Junction to Ambient 1s0p board	R_{thJA1}	–	61	–	K/W	1) 3) $T_a = 85 \text{ }^\circ\text{C}$ $T_a = 135 \text{ }^\circ\text{C}$
			–	56	–		
4.3.3	Junction to Ambient 2s2p board	R_{thJA2}	–	45	–	K/W	1) 4) $T_a = 85 \text{ }^\circ\text{C}$ $T_a = 135 \text{ }^\circ\text{C}$
			–	43	–		

- 1) Not subject to production test, specified by design. Based on simulation results.
- 2) Specified R_{thJC} value is simulated at natural convection on a cold plate setup (all pins and the exposed Pad are fixed to ambient temperature). $T_a = 85 \text{ }^\circ\text{C}$, Total power dissipation 1.5 W.
- 3) The R_{thJA} values are according to Jedec JESD51-3 at natural convection on 1s0p FR4 board. The product (chip + package) was simulated on a $76.2 \times 114.3 \times 1.5 \text{ mm}^3$ board with $70 \text{ }\mu\text{m}$ Cu, 300 mm^2 cooling area. Total power dissipation 1.5 W distributed statically and homogeneously over all power stages.
- 4) The R_{thJA} values are according to Jedec JESD51-5,-7 at natural convection on 2s2p FR4 board. The product (chip + package) was simulated on a $76.2 \times 114.3 \times 1.5 \text{ mm}^3$ board with 2 inner copper layers (outside $2 \times 70 \text{ }\mu\text{m}$ Cu, inner $2 \times 35 \text{ }\mu\text{m}$ Cu). Where applicable, a thermal via array under the exposed pad contacted the first inner copper layer. Total power dissipation 1.5 W distributed statically and homogeneously over all power stages.

EN Pin

5 EN Pin

The EN pin is a dual function pin:



Figure 3 Block Diagram EN pin

Note: The current consumption at the EN-pin I_{EN} needs to be added to the total device current consumption. The total current consumption is the sum of the currents at the VS-pin I_S and the EN-pin I_{EN} .

5.1 EN Function

If the voltage at the pin EN is below a threshold of $V_{EN(off)}$ the LITIX™ Basic IC will enter Sleep mode. In this state all internal functions are switched off, the current consumption is reduced to $I_{S(sleep)}$. A voltage above $V_{EN(on)}$ at this pin enables the device after the Power on reset time t_{POR} .

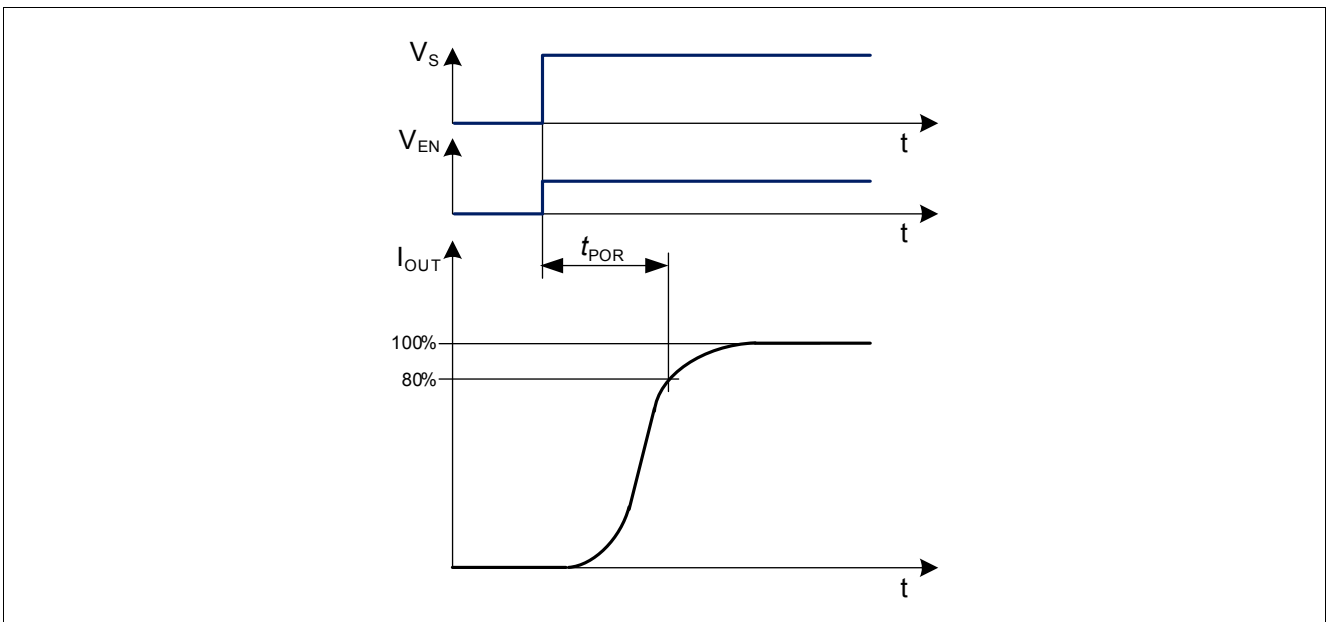

Figure 4 Power on reset

EN Pin

5.2 Internal Supply Pin

The EN pin can be used to supply the internal logic. There are two typical application conditions, where this feature can be used:

- 1) In “DC/DC control Buck” configurations, where the voltage V_S can be below 5.5V.
- 2) In configurations, where a PWM signal is applied at the Vbatt pin of a light module. The buffer capacitor C_{BUF} is used to supply the LITIX™ Basic IC during Vbatt low (V_S low) periods. This feature can be used to minimize the turn-on time to the values specified in [Pos. 10.2.15](#). Otherwise, the power-on reset delay time t_{POR} ([Pos. 6.3.8](#)) has to be considered.

The capacitor can be calculated using the following formula:

$$C_{BUF} = t_{LOW(max)} \cdot \frac{I_{EN(LS)}}{V_S - V_{D1} - V_{S(POR)}} \quad (1)$$

See also a typical application drawing in [Chapter 11](#).



Figure 5 External circuit when applying a fast PWM signal on V_{BATT}

EN Pin



Figure 6 Typical waveforms when applying a fast PWM signal on V_{BATT}

The parameter $t_{ON(VS)}$ is defined at [Pos. 10.2.15](#). The parameter $t_{OFF(VS)}$ depends on the load and supply voltage V_{BATT} characteristics.

5.3 EN Unused

In case of an unused EN pin, there are two different ways to connect it:

5.3.1 EN - Pull Up to VS

The EN pin can be connected with a pull up resistor (e.g. 10 k Ω) to V_s potential. In this configuration the LITIX™ Basic IC is always enabled.

5.3.2 EN - Direct Connection to VS

The EN pin can be connected directly to the VS pin (IC always enabled). This configuration has the advantage (compared to the configuration described in [Chapter 5.3.1](#)) that no additional external component is required.

PWMI Pin

6 PWMI Pin

The PWMI pin is designed as a dual function pin.

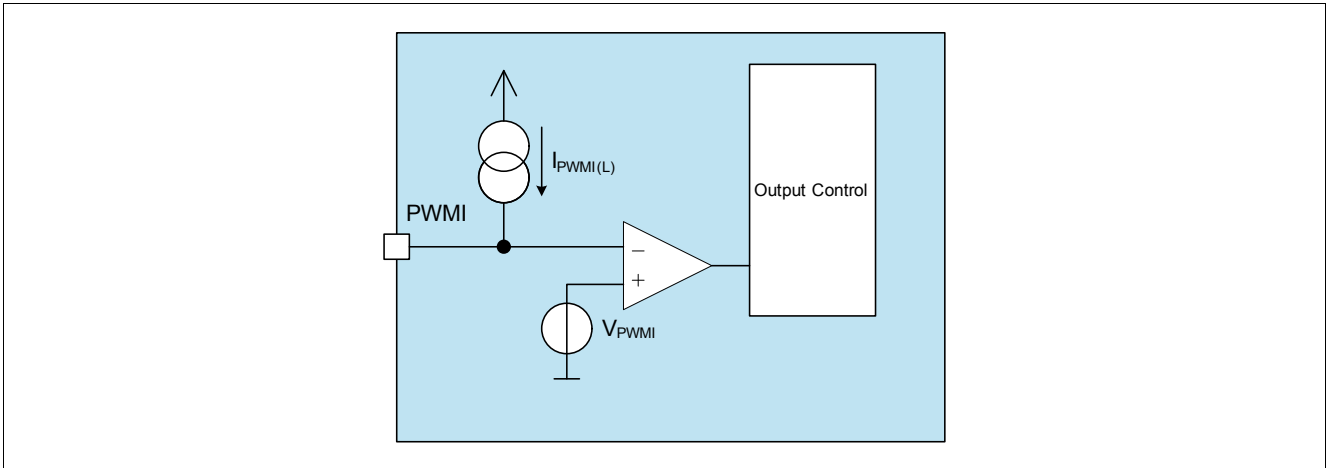

Figure 7 Block Diagram PWMI pin

The pin can be used for PWM-dimming via a push-pull stage of a micro controller, which is connecting the PWMI-pin to a low or high potential.

Note: The micro controller's push-pull stage has to be able to sink currents according to [Pos. 6.3.18](#) to activate the device.

Furthermore, the device offers also an internal PWM unit by connecting an external-RC network according to [Figure 10](#).

6.1 PWM Dimming

A PWM signal can be applied at the PWMI pin for LED brightness regulation of all 3 output stages. The dimming frequency can be adjusted in a very wide range (e.g. 400 Hz). The PWMI pin is low active. Turn on/off thresholds $V_{PWM(L)}$ and $V_{PWM(H)}$ are specified in parameters [Pos. 6.3.15](#) and [Pos. 6.3.16](#).

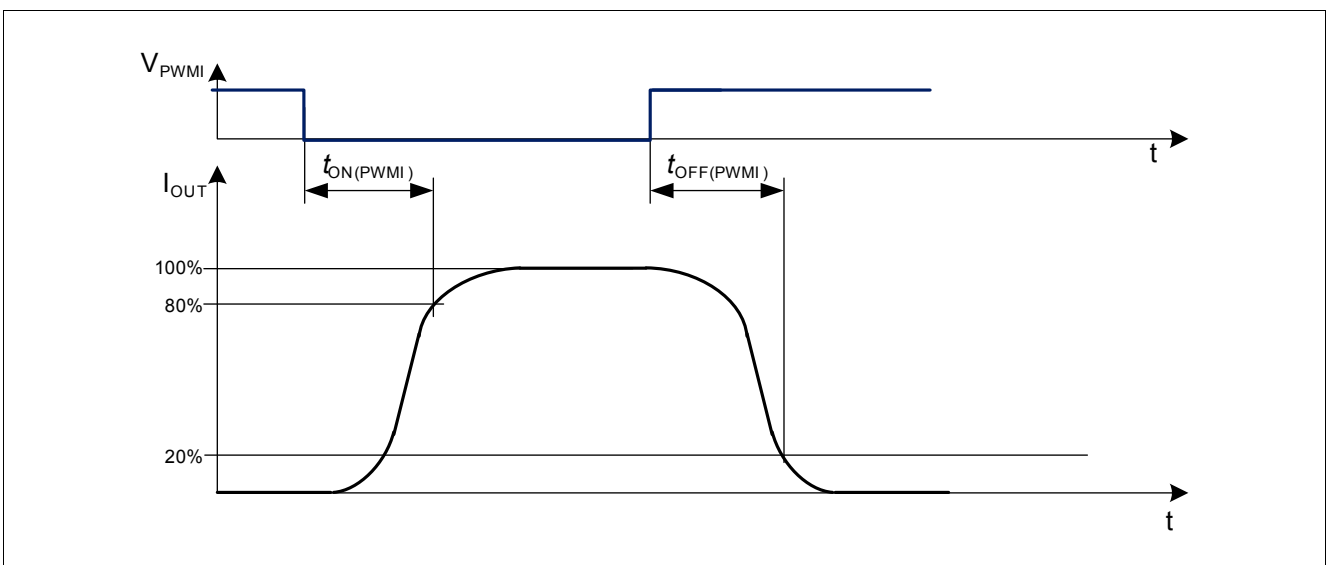

Figure 8 Turn on and Turn off time for PWMI pin usage

PWMI Pin

6.2 Internal PWM Unit

Connecting a resistor and a capacitor in parallel on the PWMI pin enables the internal pulse width modulation unit. The following figure shows the charging and discharging defined by the RC-network according to **Figure 10** and the internal PWM unit.

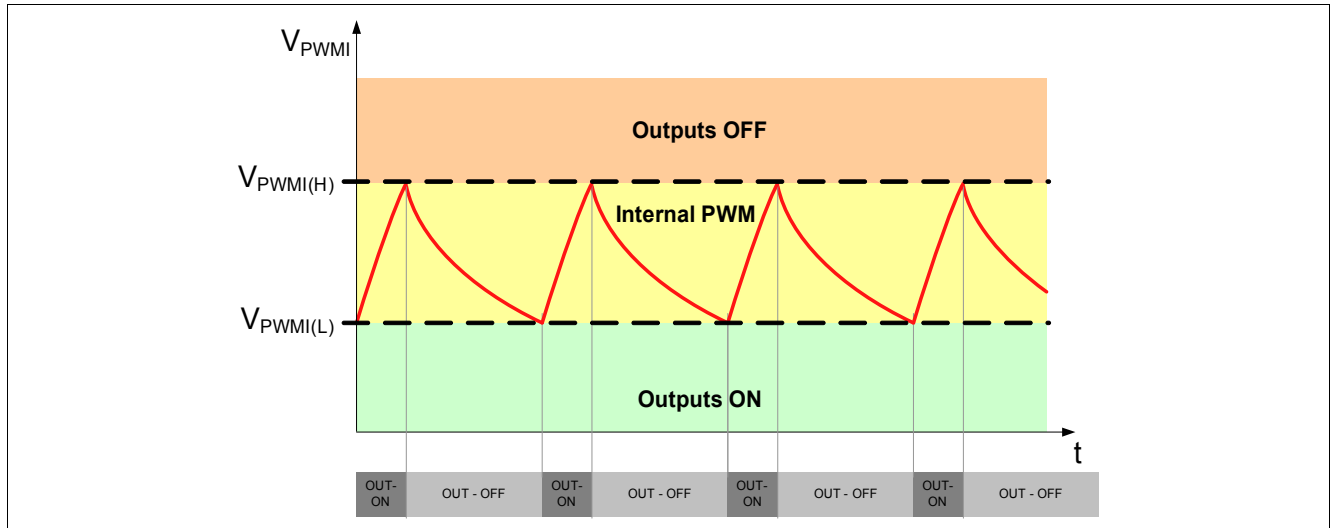

Figure 9 PWMI operating voltages

The PWM Duty cycle (DC) and the PWM frequency can be adjusted using the formulas below. Please use only typical values of $V_{PWMI(L)}$, $V_{PWMI(H)}$ and $I_{PWMI(on)}$ for the calculation of $t_{PWMI(on)}$ and $t_{PWMI(off)}$ (as described in **Pos. 6.3.15** to **Pos. 6.3.18**).

$$t_{PWMI(on)} = -R_{PWMI} \cdot C_{PWMI} \cdot \text{LN} \left(\frac{V_{PWMI(H)} - I_{PWMI(on)} \cdot R_{PWMI}}{V_{PWMI(L)} - I_{PWMI(on)} \cdot R_{PWMI}} \right) \quad (2)$$

$$t_{PWMI(off)} = R_{PWMI} \cdot C_{PWMI} \cdot \text{LN} \left(\frac{V_{PWMI(H)}}{V_{PWMI(L)}} \right) \quad (3)$$

$$f_{PWMI} = \frac{1}{t_{PWMI(on)} + t_{PWMI(off)}} \quad (4)$$

$$DC = t_{PWMI(on)} \cdot f_{PWMI} \quad (5)$$

Out of this equations the required C_{PWMI} and R_{PWMI} can be calculated:

$$C_{PWMI} = \frac{-I_{PWMI(on)} \cdot t_{PWMI(off)} \cdot \left[\left(\frac{V_{PWMI(L)}}{V_{PWMI(H)}} \right)^{t_{PWMI(off)}} - 1 \right]}{\text{LN} \left(\frac{V_{PWMI(L)}}{V_{PWMI(H)}} \right) \cdot \left[V_{PWMI(L)} \cdot \left(\frac{V_{PWMI(L)}}{V_{PWMI(H)}} \right)^{t_{PWMI(off)}} - V_{PWMI(H)} \right]} \quad (6)$$

$$R_{PWMI} = \frac{t_{PWMI(off)}}{C_{PWMI} \cdot \text{LN} \left(\frac{V_{PWMI(H)}}{V_{PWMI(L)}} \right)} \quad (7)$$

PWMI Pin

See **Figure 10** for a typical external circuitry.

Note: In case of junction temperatures above $T_{j(CRT)}$ (**Pos. 10.2.16**) the device provides a temperature dependent current reduction feature as described in **Chapter 10.1.1**. In case of output current reduction I_{IN_SET} is reduced as well, which leads to increased turn on-times $t_{PWMI(on)}$, because the C_{PWMI} is charged slower. The turn off-time $t_{PWMI(off)}$ remains the same.

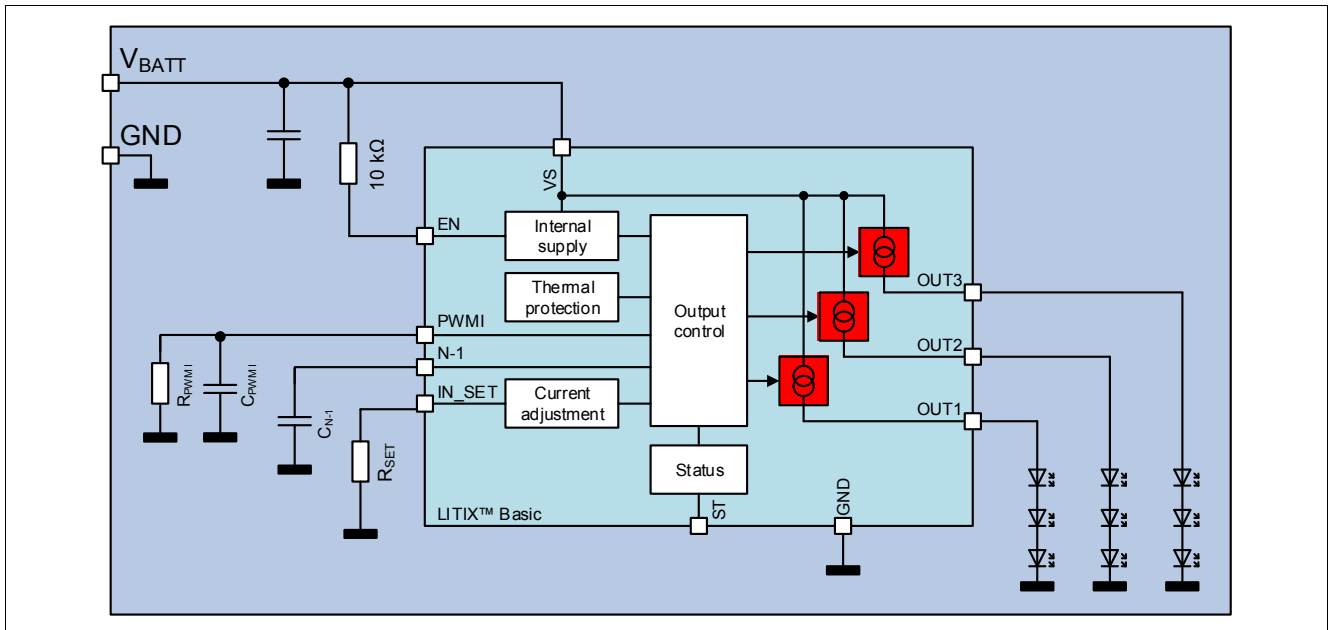

Figure 10 Typical circuit using internal PWM unit

PWMI Pin

6.3 Electrical Characteristics Internal Supply / EN / PWMI Pin

Electrical Characteristics Internal Supply / EN / PWMI pin

Unless otherwise specified: $V_S = 5.5\text{ V to }40\text{ V}$, $T_j = -40^\circ\text{C to }+150^\circ\text{C}$, $R_{SET} = 12\text{ k}\Omega$ all voltages with respect to ground, positive current flowing into pin for input pins (I), positive currents flowing out of the I/O and output pins (O) (unless otherwise specified)

Pos.	Parameter	Symbol	Limit Values			Unit	Conditions
			Min.	Typ.	Max.		
6.3.1	Current consumption, sleep mode	$I_{S(\text{sleep})}$	-	0.1	2	μA	¹⁾ $V_{EN} = 0.5\text{ V}$ $T_j < 85^\circ\text{C}$ $V_S = 18\text{ V}$ $V_{OUTx} = 3.6\text{ V}$
6.3.2	Current consumption, active mode	$I_{S(\text{on})}$	-	-	1.4	mA	²⁾ $V_{PWMI} = 0.5\text{ V}$ $I_{IN_SET} = 0\text{ }\mu\text{A}$ $T_j < 105^\circ\text{C}$ $V_S = 18\text{ V}$ $V_{OUTx} = 3.6\text{ V}$ $V_{EN} = 5.5\text{ V}$ $V_{EN} = 18\text{ V}$ ¹⁾ $R_{EN} = 10\text{ k}\Omega$ between VS and EN-pin
6.3.3	Current consumption, device disabled via ST	$I_{S(\text{dis,ST})}$	-	-	1.4	mA	²⁾ $V_S = 18\text{ V}$ $T_j < 105^\circ\text{C}$ $V_{ST} = 5\text{ V}$ $V_{EN} = 5.5\text{ V}$ $V_{EN} = 18\text{ V}$ ¹⁾ $R_{EN} = 10\text{ k}\Omega$ between VS and EN-pin
6.3.4	Current consumption, device disabled via IN_SET	$I_{S(\text{dis,IN_SET})}$	-	-	1.4	mA	²⁾ $V_S = 18\text{ V}$ $T_j < 105^\circ\text{C}$ $V_{IN_SET} = 5\text{ V}$ $V_{EN} = 5.5\text{ V}$ $V_{EN} = 18\text{ V}$ ¹⁾ $R_{EN} = 10\text{ k}\Omega$ between VS and EN-pin
6.3.5	Current consumption, device disabled via PWMI	$I_{S(\text{dis,PWMI})}$	-	-	1.6	mA	²⁾ $V_S = 18\text{ V}$ $T_j < 105^\circ\text{C}$ $V_{PWMI} = 3.4\text{ V}$ $V_{EN} = 5.5\text{ V}$ $V_{EN} = 18\text{ V}$ ¹⁾ $R_{EN} = 10\text{ k}\Omega$ between VS and EN-pin

PWMI Pin

Electrical Characteristics Internal Supply / EN / PWMI pin (cont'd)

Unless otherwise specified: $V_S = 5.5\text{ V to }40\text{ V}$, $T_j = -40^\circ\text{C to }+150^\circ\text{C}$, $R_{SET} = 12\text{ k}\Omega$ all voltages with respect to ground, positive current flowing into pin for input pins (I), positive currents flowing out of the I/O and output pins (O) (unless otherwise specified)

Pos.	Parameter	Symbol	Limit Values			Unit	Conditions
			Min.	Typ.	Max.		
6.3.6	Current consumption, active mode in single fault detection condition with ST-pin unconnected	$I_{S(\text{fault,STu})}$	-	-	1.7 1.1 1.8	mA	²⁾ $V_S = 18\text{ V}$ $T_j < 105^\circ\text{C}$ $R_{SET} = 12\text{ k}\Omega$ $V_{PWMI} = 0.5\text{ V}$ $V_{OUTx} = 18\text{ V}$ $V_{EN} = 5.5\text{ V}$ $V_{EN} = 18\text{ V}$ ¹⁾ $R_{EN} = 10\text{ k}\Omega$ between VS and EN-pin
6.3.7	Current consumption, active mode in single fault detection condition with ST-pin connected to GND	$I_{S(\text{fault,STG})}$	-	-	6.0 4.9 5.9	mA	²⁾ $V_S = 18\text{ V}$ $T_j < 105^\circ\text{C}$ $R_{SET} = 12\text{ k}\Omega$ $V_{PWMI} = 0.5\text{ V}$ $V_{OUTx} = 18\text{ V}$ $V_{ST} = 0\text{ V}$ $V_{EN} = 5.5\text{ V}$ $V_{EN} = 18\text{ V}$ ¹⁾ $R_{EN} = 10\text{ k}\Omega$ between VS and EN-pin
6.3.8	Power-on reset delay time ³⁾	t_{POR}	-	-	25	μs	¹⁾ $V_S = V_{EN} = 0 \rightarrow 13.5\text{ V}$ $V_{OUTx(\text{nom})} = 3.6 \pm 0.3\text{ V}$ $I_{OUTx} = 80\% I_{OUTx(\text{nom})}$
6.3.9	Required supply voltage for output activation	$V_{S(\text{on})}$	-	-	4	V	$V_{EN} = 5.5\text{ V}$ $V_{OUTx} = 3\text{ V}$ $I_{OUTx} = 50\% I_{OUTx(\text{nom})}$
6.3.10	Required supply voltage for current control	$V_{S(\text{CC})}$	-	-	5.2	V	$V_{EN} = 5.5\text{ V}$ $V_{OUTx} = 3.6\text{ V}$ $I_{OUTx} \geq 90\% I_{OUTx(\text{nom})}$
6.3.11	EN turn on threshold	$V_{EN(\text{on})}$	-	-	2.5	V	-
6.3.12	EN turn off threshold	$V_{EN(\text{off})}$	0.8	-	-	V	-
6.3.13	EN input current during low supply voltage	$I_{EN(\text{LS})}$	-	-	1.8	mA	¹⁾ $V_S = 4.5\text{ V}$ $T_j < 105^\circ\text{C}$ $V_{EN} = 5.5\text{ V}$
6.3.14	EN high input current	$I_{EN(\text{H})}$	-	-	0.1 0.1 1.65 0.45	mA	$T_j < 105^\circ\text{C}$ $V_S = 13.5\text{ V}, V_{EN} = 5.5\text{ V}$ $V_S = 18\text{ V}, V_{EN} = 5.5\text{ V}$ $V_S = V_{EN} = 18\text{ V}$ ¹⁾ $V_S = 18\text{ V}, R_{EN} = 10\text{ k}\Omega$ between VS and EN-pin

PWMI Pin

Electrical Characteristics Internal Supply / EN / PWMI pin (cont'd)

Unless otherwise specified: $V_S = 5.5\text{ V to }40\text{ V}$, $T_j = -40^\circ\text{C to }+150^\circ\text{C}$, $R_{SET} = 12\text{ k}\Omega$ all voltages with respect to ground, positive current flowing into pin for input pins (I), positive currents flowing out of the I/O and output pins (O) (unless otherwise specified)

Pos.	Parameter	Symbol	Limit Values			Unit	Conditions
			Min.	Typ.	Max.		
6.3.15	PWMI (active low) Switching low threshold (outputs on)	$V_{PWMI(L)}$	1.5	1.85	2.3	V	¹⁾⁴⁾ $V_S = 8\dots18\text{ V}$
6.3.16	PWMI(active low) Switching high threshold (outputs off)	$V_{PWMI(H)}$	2.45	2.85	3.2	V	¹⁾⁴⁾⁵⁾ $V_S = 8\dots18\text{ V}$
6.3.17	PWMI Switching threshold difference $V_{PWMI(H)} - V_{PWMI(L)}$	ΔV_{PWMI}	0.75	1	1.10	V	¹⁾⁴⁾⁵⁾ $V_S = 8\dots18\text{ V}$
6.3.18	PWMI (active low) Low input current with active channels (voltage < $V_{PWMI(L)}$)	$I_{PWMI(on)}$	I_{IN_SET} *3.1	I_{IN_SET} *4	I_{IN_SET} *4.9	μA	¹⁾ $T_j = 25\dots115^\circ\text{C}$ $I_{IN_SET} = 100\ \mu\text{A}$ $V_{PWMI} = 1.7\text{ V}$ $V_{EN} = 5.5\text{ V}$ $V_S = 8\dots18\text{ V}$
6.3.19	PWMI(active low) High input current	$I_{PWMI(off)}$	-5	-	5	μA	$V_{PWMI} = 5\text{ V}$ $V_{EN} = 5.5\text{ V}$ $V_S = 8\dots18\text{ V}$

- 1) Not subject to production test, specified by design
- 2) The total device current consumption is the sum of the currents I_S and $I_{EN(H)}$, please refer to **Pos. 6.3.14**
- 3) See also **Figure 4**
- 4) Parameter valid if an external PWM signal is applied
- 5) If TTL level compatibility is required, use μC open drain output with pull up resistor

IN_SET Pin

7 IN_SET Pin

The IN_SET pin is a multiple function pin for output current definition, input and diagnostics:

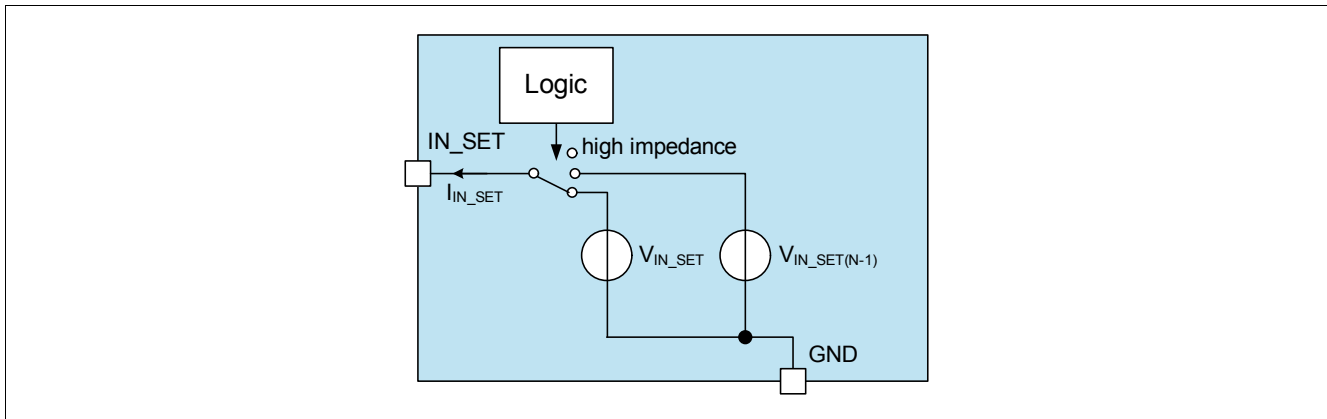

Figure 11 Block Diagram IN_SET pin

7.1 Output Current Adjustment via RSET

The output current for all three channels can only be adjusted simultaneously. The current adjustment can be done by placing a low power resistor (R_{SET}) at the IN_SET pin to ground. The dimensioning of the resistor can be done using the formula below:

$$R_{SET} = \frac{k}{I_{OUT}} \quad (8)$$

The gain factor k ($R_{SET} \cdot$ output current) is specified in [Pos. 10.2.4](#) and [Pos. 10.2.5](#). The current through the R_{SET} is defined by the resistor itself and the reference voltage $V_{IN_SET(ref)}$, which is applied to the IN_SET during supplied device.

7.2 Smart Input Pin

The IN_SET pin can be connected via R_{SET} to the open-drain output of a μC or to an external NMOS transistor as described in [Figure 12](#). This signal can be used to turn off the output stages of the IC. A minimum IN_SET current of $I_{IN_SET(act)}$ is required to turn on the output stages. This feature is implemented to prevent glimming of LEDs caused by leakage currents on the IN_SET pin, see [Figure 15](#) for details. In addition, the IN_SET pin offers the diagnostic feedback information, if the status pin is connected to GND. Another diagnostic possibility is shown in [Figure 13](#), where the diagnosis information is provided via the ST pin (refer to [Chapter 8](#) and [Chapter 9](#)) to a micro controller. In case of a fault event with the ST pin connected to GND the IN_SET voltage is increased to $V_{IN_SET(N-1)}$ [Pos. 9.3.2](#). Therefore, the device has two voltage domains at the IN_SET-pin, which is shown in [Figure 16](#).

IN_SET Pin

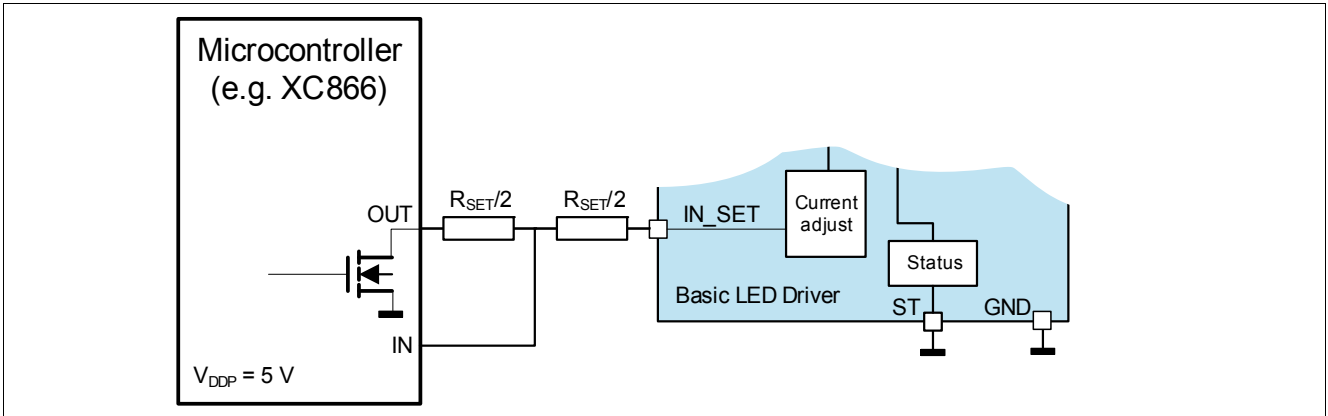

Figure 12 Schematics IN_SET interface to μ C, diagnosis via IN_SET pin

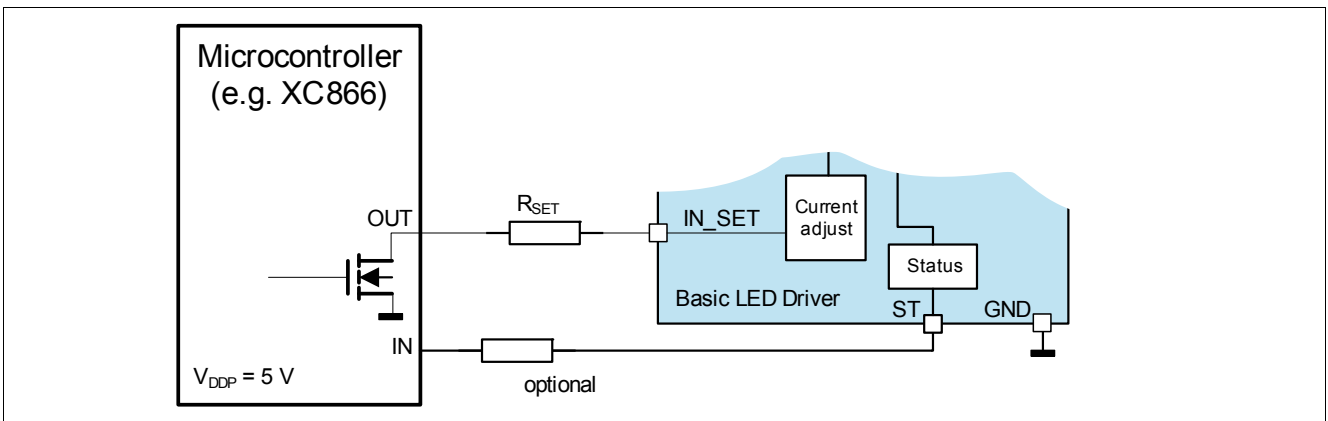

Figure 13 Schematics IN_SET interface to μ C, diagnosis via ST pin

The resulting switching times are shown in [Figure 14](#):

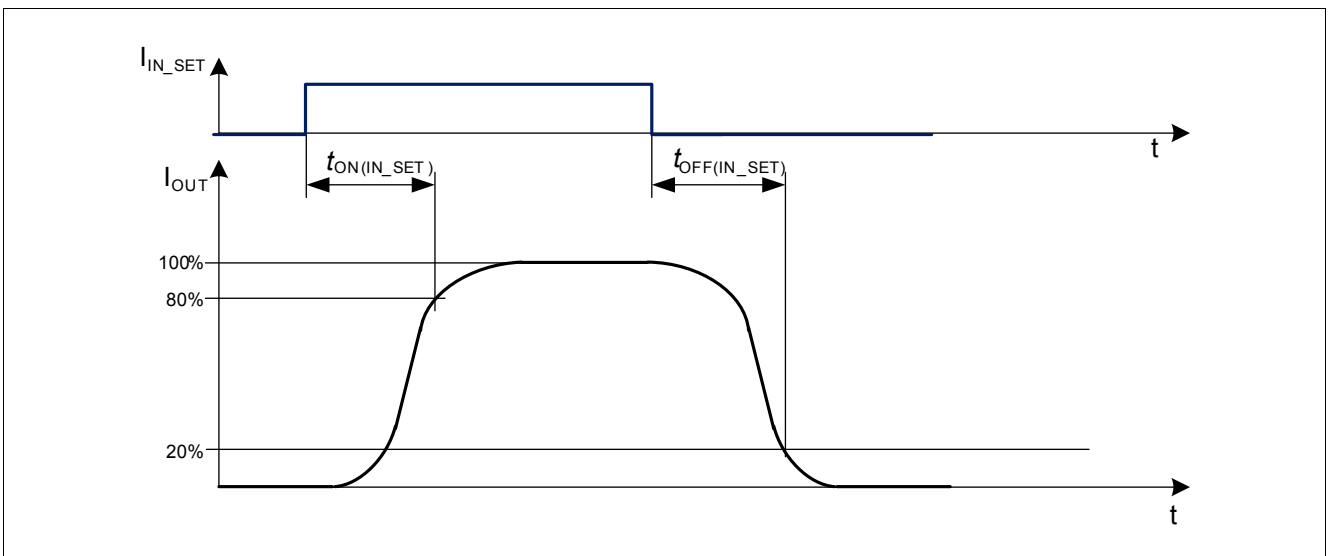

Figure 14 Switching times via IN_SET

IN_SET Pin

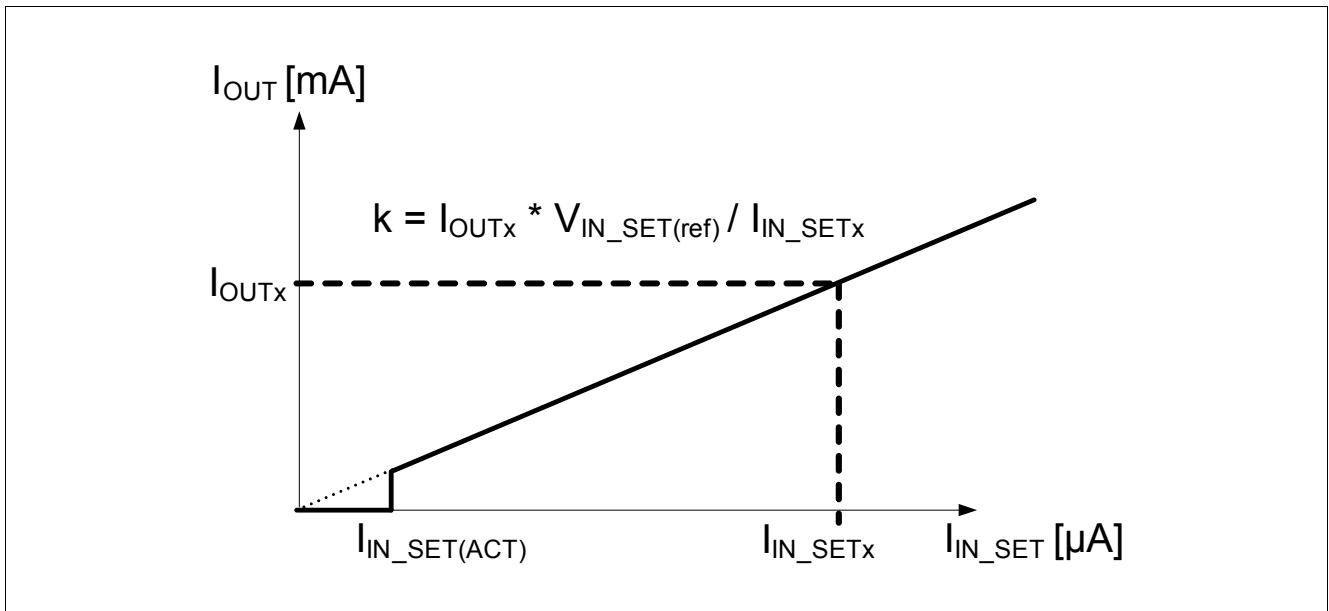

Figure 15 I_{OUT} versus I_{INSET}

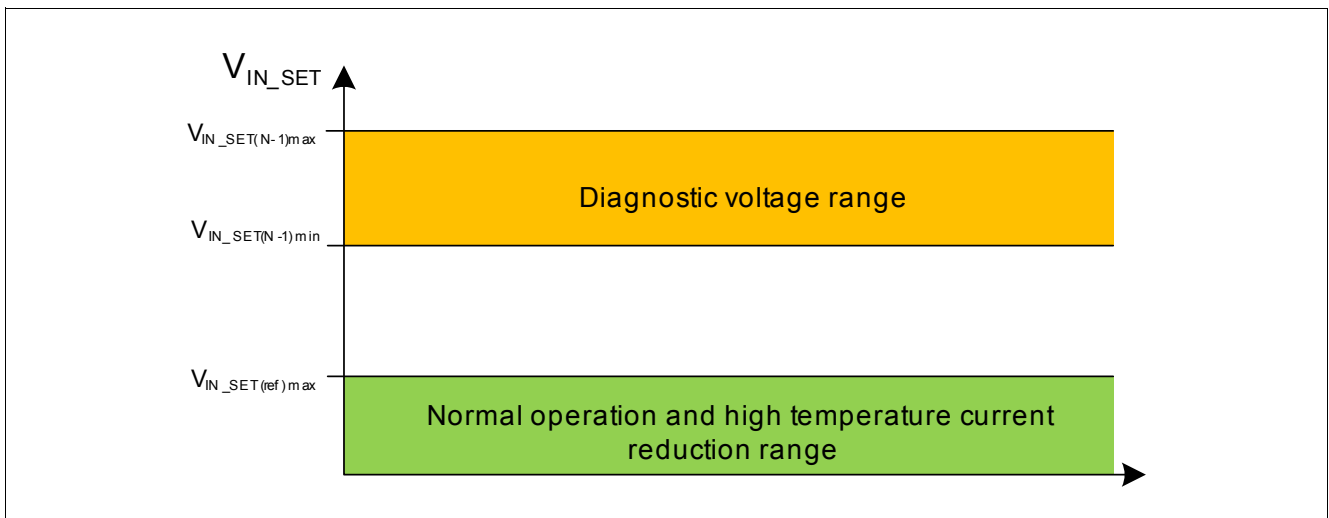

Figure 16 Voltage domains for IN_SET pin, if ST pin is connected to GND

8 ST Pin

The ST pin is a multiple function pin.

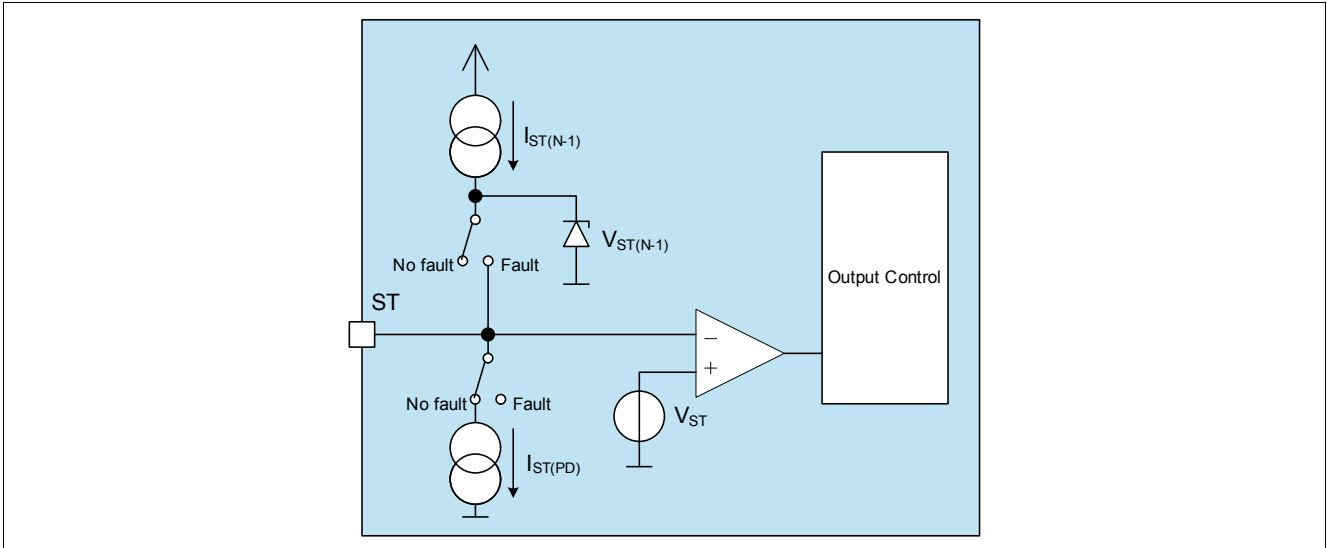

Figure 17 Block Diagram ST pin

8.1 Diagnosis Selector

If the status pin is unconnected or connected to GND via a high ohmic resistor (V_{ST} to be below $V_{ST(L)}$), the ST pin acts as diagnosis output pin. In normal operation (device is activated) the ST pin is pulled to GND via the internal pull down current $I_{ST(PD)}$. In case of an open load condition the ST pin is switched to $V_{ST(N-1)}$ after the N-1 detection filter time.

If the device is operated in PWM operation via the VS and/or EN pins the ST pin should be connected to GND via a high ohmic resistor (e.g. 470 kΩ) to ensure proper device behavior during fast rising VS and/or EN slopes. If the ST pin is shorted to GND the diagnostic feedback is performed via the IN_SET-pin, which is shown in [Chapter 7.2](#) and [Chapter 9](#).

8.2 Diagnosis Output

If the status pin is unconnected or connected to GND via a high ohmic resistor (V_{ST} to be below $V_{ST(L)}$), it acts as a diagnostic output. In case of a fault condition the ST pin rises its voltage to $V_{ST(N-1)}$ ([Pos. 9.3.7](#)). Details are shown in [Chapter 9](#).

8.3 Disable Input

If an external voltage higher than $V_{ST(H)}$ ([Pos. 9.3.5](#)) is applied to the ST pin, the device is switched off. This function is used for applications, where multiple drivers should be used for one light function. It is possible to combine the drivers' fault diagnosis via the ST pins. If a single LED chain fails, the entire light function is switched off. In this scenario e.g. the diagnostic circuit on the body control module can easily distinguish between the two cases (normal load or load fault), because nearly no current is flowing into the LED module during the fault scenario - the drivers consume a current of $I_{S(fault,STu)}$ ([Pos. 6.3.6](#)) or $I_{S(dis,ST)}$ ([Pos. 6.3.3](#)).

As soon as one LED chain fails, the ST-pin of this device is switched to $V_{ST(N-1)}$. The other devices used for the same light function can be connected together via the ST pins. This leads to a switch off of all devices connected together. Application examples are shown in [Chapter 11](#).

ST Pin

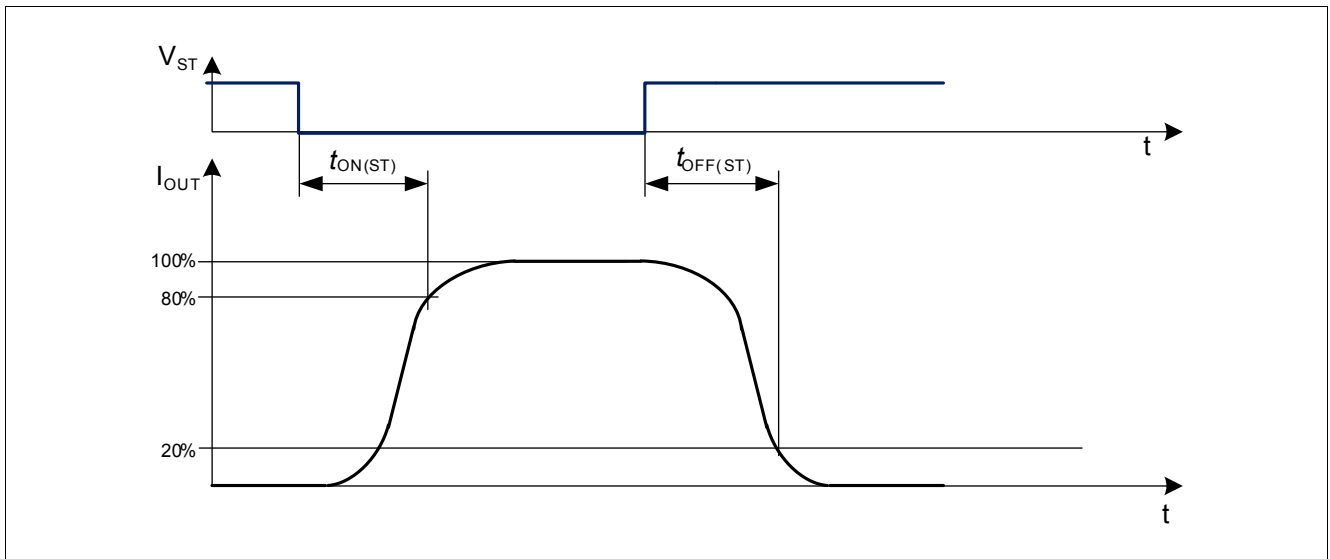

Figure 18 Switching times via ST Pin

9 Load Diagnosis

9.1 N-1 Detection

The N-1 diagnosis is specially designed to detect error conditions in LED arrays with multiple LED chains used for one light function. If one LED within one chain fails in open condition the respective LED chain is off. Different automotive applications require a complete deactivation of a light function, if the desired brightness of the function (LED array) can not be achieved due to an internal error condition. Such a deactivation feature is integrated in the LITIX™ Basic IC.

The functionality of the N-1 pin is shown in the following block diagram:

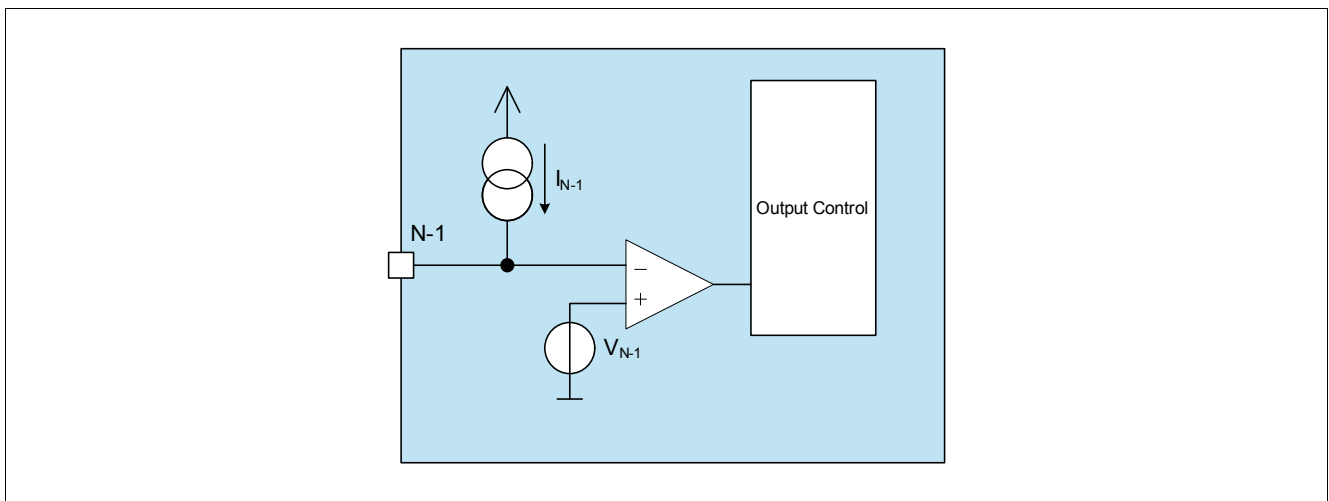

Figure 19 Block Diagram N-1 pin

In applications, where more than one LITIX™ Basic IC is used, the devices can be connected via the ST pins as shown in [Figure 23](#). This circuit can be used to disable all output stages (of all LITIX™ Basic ICs) during an open load event on one channel. The outputs are deactivated after a N-1 filter time t_{N-1} , which is defined by the charging current I_{N-1} ([Pos. 9.3.10](#)). The time is adjustable with a capacitor connected to the N-1 pin according the following equation:

$$t_{typ} = \frac{C_{N-1} \cdot V_{N-1(th)}}{I_{N-1}} \quad (9)$$

Load Diagnosis

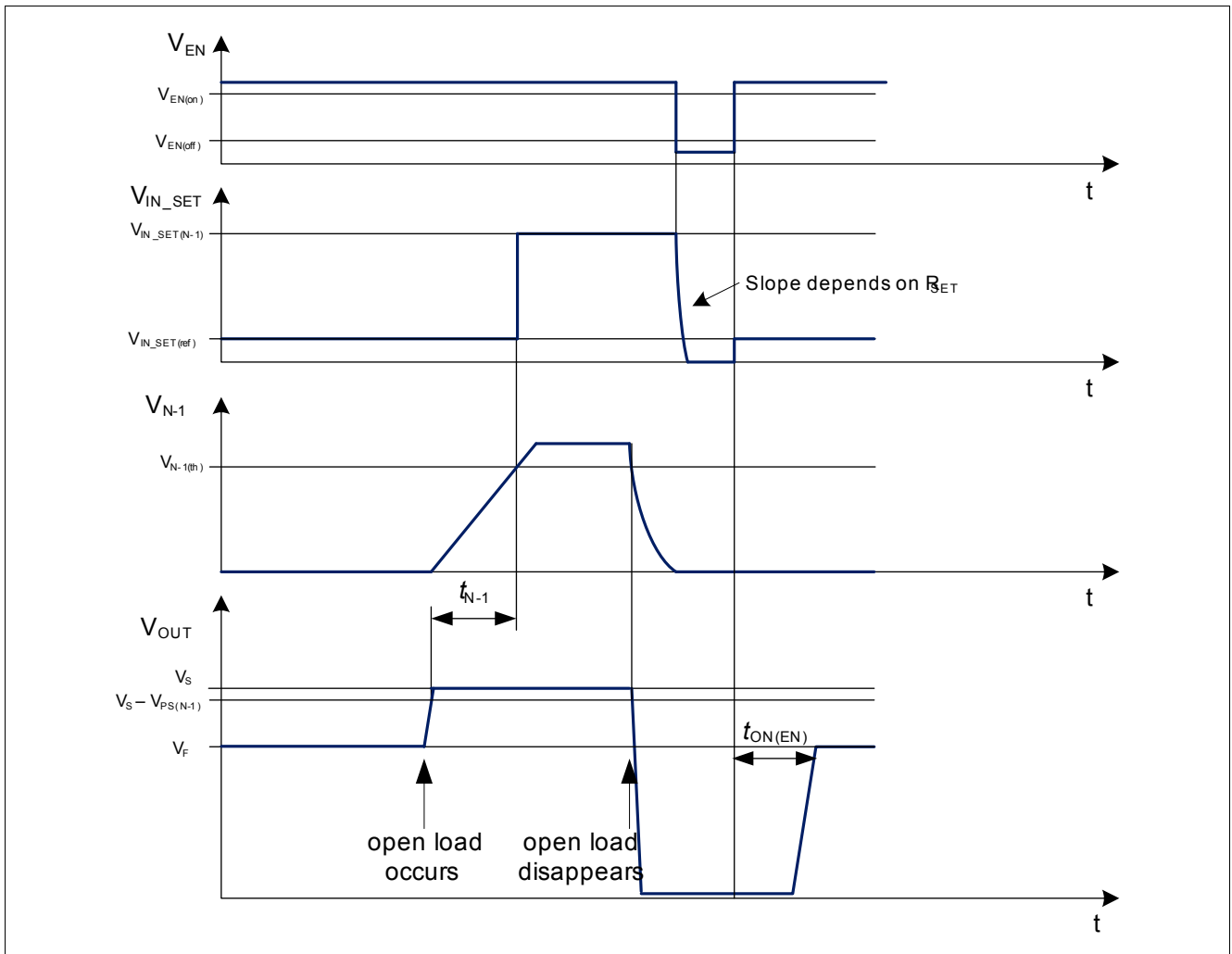

Figure 20 IN_SET behavior during open load condition with ST pin connected to GND

Load Diagnosis

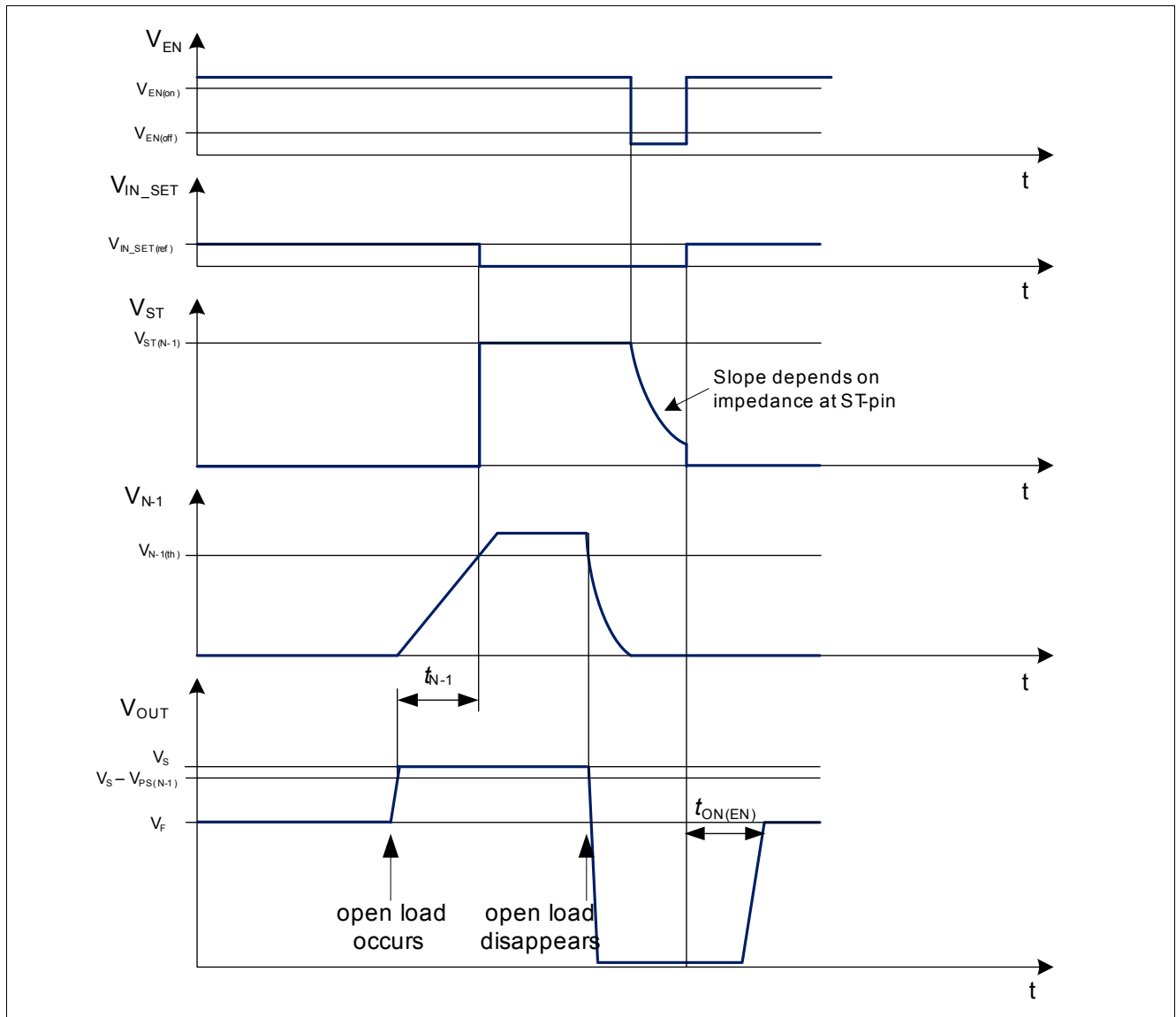

Figure 21 IN_SET and ST behavior during open load condition (ST unconnected)

The N-1 status is latched. The output stages can be re-enabled by a Low to High transition at the EN pin or by a Power on reset. To provide a Limp Home functionality (lower number of LEDs instead of complete deactivation) in the case of a partially damaged LED array, the N-1 filter time t_{N-1} can be used. If a PWM signal with an ON-time of less than t_{N-1} is applied to the VS and EN pins, the N-1 detection feature will not be activated.

If there is more than one device used for N-1 detection the maximum number of devices, which can be connected as shown in [Figure 23](#), is limited to n_{N-1} . The maximum number of devices in N-1 configuration is

Load Diagnosis

calculated according to [Equation \(10\)](#), and the precondition of [Equation \(11\)](#) has to be fulfilled. The pull-down resistor R_{PWMI} is calculated according to [Equation \(12\)](#) and [Equation \(13\)](#).

$$n_{N-1} \leq \frac{\left(I_{\text{IN_SET(OL,min)}} - \frac{V_{\text{PWMI(H,max)}} + V_{\text{F}}}{R_{\text{SET(min)}}} \right) \cdot V_{\text{PWMI(H,min)}} \cdot R_{\text{SET(min)}}}{V_{\text{PWMI(H,max)}} \cdot 4 \cdot V_{\text{IN_SET(max)}}} \quad (10)$$

$$\frac{V_{\text{PWMI(H,min)}} \cdot V_{\text{IN_SET(min)}} \cdot R_{\text{SET(min)}}}{(V_{\text{IN_SET(max)}})^2 \cdot R_{\text{SET(max)}}} > 1 \quad (11)$$

$$R_{\text{PWMI(min)}} = \frac{V_{\text{PWMI(H,max)}}}{I_{\text{IN_SET(OL,min)}} - \frac{V_{\text{PWMI(H,max)}} + V_{\text{F}}}{R_{\text{SET(max)}}}} \quad (12)$$

$$R_{\text{PWMI(max)}} = \frac{V_{\text{PWMI(H,min)}}}{n_{N-1} \cdot 4 \cdot \frac{V_{\text{IN_SET(max)}}}{R_{\text{SET(min)}}}} \quad (13)$$

V_{F} represents the voltage drop across the diode between the IN_SET- and the PWMI-pin.

Note: If one channel of the device should not be used, the according output needs to be connected to GND, which leads to a disabling of this output.

Note: In case of a double fault, where the loads of two channels are faulty at the same time, the device operates as in normal operation. This feature is implemented to avoid any unwanted switch off during significant supply voltage drops. Please refer to [Chapter 9.2](#).

9.2 Double Fault Conditions

The TLD1315EL has an integrated double fault detection feature. This feature is implemented to detect significant supply voltage drops. During such supply voltage drops close to the forward voltage of the LEDs the drivers outputs remain active. In case of load faults on two or more outputs within the time period t_{N-1} the device disables the diagnosis to avoid any uncorrect open load diagnosis during low supply voltages close to the forward voltages of the connected LED chains. If the faults between two or three channels happen with a delay of longer than t_{OL} the double fault detection feature is not active, i.e. the device is not turned on.

9.3 Electrical Characteristics IN_SET Pin and Load Diagnosis

Electrical Characteristics IN_SET pin and Load Diagnosis

Unless otherwise specified: $V_{\text{S}} = 5.5 \text{ V to } 40 \text{ V}$, $T_{\text{j}} = -40^{\circ}\text{C to } +150^{\circ}\text{C}$, $R_{\text{SET}} = 12 \text{ k}\Omega$, all voltages with respect to ground, positive current flowing into pin for input pins (I), positive currents flowing out of the I/O and output pins (O) (unless otherwise specified)

Pos.	Parameter	Symbol	Limit Values			Unit	Conditions
			Min.	Typ.	Max.		
9.3.1	IN_SET reference voltage	$V_{\text{IN_SET(ref)}}$	1.19	1.23	1.27	V	¹⁾ $V_{\text{OUTx}} = 3.6 \text{ V}$ $T_{\text{j}} = 25 \dots 115^{\circ}\text{C}$
9.3.2	IN_SET N_1 voltage	$V_{\text{IN_SET(N-1)}}$	4	–	5.5	V	¹⁾ $V_{\text{S}} > 8 \text{ V}$ $T_{\text{j}} = 25 \dots 150^{\circ}\text{C}$ $V_{\text{S}} = V_{\text{OUTx}}(\text{OL})_{\text{x}}$

Load Diagnosis

Electrical Characteristics IN_SET pin and Load Diagnosis (cont'd)

Unless otherwise specified: $V_S = 5.5\text{ V}$ to 40 V , $T_j = -40^\circ\text{C}$ to $+150^\circ\text{C}$, $R_{SET} = 12\text{ k}\Omega$, all voltages with respect to ground, positive current flowing into pin for input pins (I), positive currents flowing out of the I/O and output pins (O) (unless otherwise specified)

Pos.	Parameter	Symbol	Limit Values			Unit	Conditions
			Min.	Typ.	Max.		
9.3.3	IN_SET N_1 current	$I_{IN_SET(N-1)}$	1.5	–	7.4	mA	¹⁾ $V_S > 8\text{ V}$ $T_j = 25\dots150\text{ }^\circ\text{C}$ $V_{IN_SET} = 4\text{ V}$ $V_S = V_{OUTx}\text{ (OL)}$
9.3.4	ST device turn on threshold (active low) in case of voltage applied from external (ST-pin acting as input)	$V_{ST(L)}$	0.8	–	–	V	–
9.3.5	ST device turn off threshold (active low) in case of voltage applied from external (ST-pin acting as input)	$V_{ST(H)}$	–	–	2.5	V	–
9.3.6	ST pull down current	$I_{ST(PD)}$	–	–	15	μA	$V_{EN} = 5.5\text{ V}$ $V_{ST} = 0.8\text{ V}$
9.3.7	ST N_1 voltage (ST-pin acting as diagnosis output)	$V_{ST(N-1)}$	4	–	5.5	V	¹⁾ $V_S > 8\text{ V}$ $T_j = 25\dots150\text{ }^\circ\text{C}$ $R_{ST} = 470\text{ k}\Omega$ $V_S = V_{OUTx}\text{ (OL)}$
9.3.8	ST N_1 current (ST-pin acting as diagnosis output)	$I_{ST(N-1)}$	100	–	220	μA	¹⁾ $V_S > 8\text{ V}$ $T_j = 25\dots150\text{ }^\circ\text{C}$ $V_{ST} = 2.5\text{ V}$ $V_S = V_{OUTx}\text{ (OL)}$
9.3.9	N-1 high threshold	$V_{N-1(th)}$	2.45	2.85	3.2	V	$V_S > 8\text{ V}$
9.3.10	N-1 output current	I_{N-1}	12	20	28	μA	$V_S > 8\text{ V}$ $V_{N-1} = 2\text{ V}$
9.3.11	N-1 detection voltage $V_{PS(N-1)} = V_S - V_{OUTx}$	$V_{PS(N-1)}$	0.2	–	0.4	V	$V_S > 8\text{ V}$
9.3.12	IN_SET activation current without turn on of output stages	$I_{IN_SET(act)}$	2	–	15	μA	See Figure 15

1) Not subject to production test, specified by design

Power Stage

10 Power Stage

The output stages are realized as high side current sources with a current of 120 mA. During off state the leakage current at the output stage is minimized in order to prevent a slightly glowing LED.

The maximum current of each channel is limited by the power dissipation and used PCB cooling areas (which results in the applications R_{thJA}).

For an operating current control loop the supply and output voltages according to the following parameters have to be considered:

- Required supply voltage for current control $V_{S(CC)}$, **Pos. 6.3.10**
- Voltage drop over output stage during current control $V_{PS(CC)}$, **Pos. 10.2.6**
- Required output voltage for current control $V_{OUTx(CC)}$, **Pos. 10.2.7**

10.1 Protection

The device provides embedded protective functions, which are designed to prevent IC destruction under fault conditions described in this data sheet. Fault conditions are considered as “outside” normal operating range. Protective functions are neither designed for continuous nor for repetitive operation.

10.1.1 Over Load Behavior

An over load detection circuit is integrated in the LITIX™ Basic IC. It is realized by a temperature monitoring of the output stages (OUTx).

As soon as the junction temperature exceeds the current reduction temperature threshold $T_{j(CRT)}$ the output current will be reduced by the device by reducing the IN_SET reference voltage $V_{IN_SET(ref)}$. This feature avoids LED’s flickering during static output overload conditions. Furthermore, it protects LEDs against over temperature, which are mounted thermally close to the device. If the device temperature still increases, the three output currents decrease close to 0 A. As soon as the device cools down the output currents rise again.

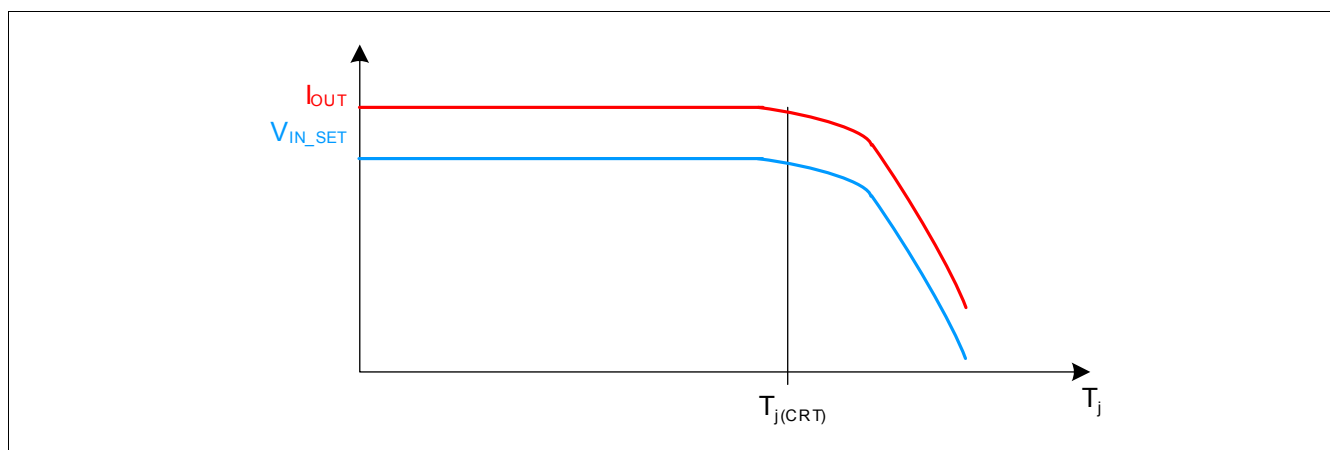

Figure 22 Output current reduction at high temperature

Note: This high temperature output current reduction is realized by reducing the IN_SET reference voltage (Pos. 9.3.1). In case of very high power loss applied to the device and very high junction temperature the output current may drop down to $I_{OUTx} = 0$ mA, after a slight cooling down the current increases again.

10.1.2 Reverse Battery Protection

The TLD1315EL has an integrated reverse battery protection feature. This feature protects the driver IC itself, but also connected LEDs. The output reverse current is limited to $I_{OUTx(rev)}$ by the reverse battery protection.

Power Stage

Note: Due to the reverse battery protection a reverse protection diode for the light module may be obsolete. In case of high ISO-pulse requirements and only minor protecting components like capacitors a reverse protection diode may be reasonable. The external protection circuit needs to be verified in the application.

10.2 Electrical Characteristics Power Stage

Electrical Characteristics Power Stage

Unless otherwise specified: $V_S = 5.5\text{ V to }18\text{ V}$, $T_j = -40^\circ\text{C to }+150^\circ\text{C}$, $V_{OUTx} = 3.6\text{ V}$, all voltages with respect to ground, positive current flowing into pin for input pins (I), positive currents flowing out of the I/O and output pins (O) (unless otherwise specified)

Pos.	Parameter	Symbol	Limit Values			Unit	Conditions
			Min.	Typ.	Max.		
10.2.1	Output leakage current	$I_{OUTx(leak)}$	-	-	7 3	μA	$V_{EN} = 5.5\text{ V}$ $I_{IN_SET} = 0\ \mu\text{A}$ $V_{OUTx} = 2.5\text{ V}$ $T_j = 150^\circ\text{C}$ ¹⁾ $T_j = 85^\circ\text{C}$
10.2.2	Output leakage current in boost over battery setup	$I_{OUTx(leak,B2B)}$	-	-	50	μA	¹⁾ $V_{EN} = 5.5\text{ V}$ $I_{IN_SET} = 0\ \mu\text{A}$ $V_{OUTx} = V_S = 40\text{ V}$
10.2.3	Reverse output current	$-I_{OUTx(rev)}$	-	-	1	μA	¹⁾ $V_S = -16\text{ V}$ Output load: LED with break down voltage < - 0.6 V
10.2.4	Output current accuracy limited temperature range	k_{LT}	697 645	750 750	803 855		¹⁾ $T_j = 25...115^\circ\text{C}$ $V_S = 8...18\text{ V}$ $V_{PS} = 2\text{ V}$ $R_{SET} = 6...12\text{ k}\Omega$ $R_{SET} = 30\text{ k}\Omega$
10.2.5	Output current accuracy over temperature	k_{ALL}	697 645	750 750	803 855		¹⁾ $T_j = -40...115^\circ\text{C}$ $V_S = 8...18\text{ V}$ $V_{PS} = 2\text{ V}$ $R_{SET} = 6...12\text{ k}\Omega$ $R_{SET} = 30\text{ k}\Omega$
10.2.6	Voltage drop over power stage during current control $V_{PS(CC)} = V_S - V_{OUTx}$	$V_{PS(CC)}$	0.75	-	-	V	¹⁾ $V_S = 13.5\text{ V}$ $R_{SET} = 12\text{ k}\Omega$ $I_{OUTx} \geq 90\%$ of $(k_{LT(typ)}/R_{SET})$
10.2.7	Required output voltage for current control	$V_{OUTx(CC)}$	2.3	-	-	V	¹⁾ $V_S = 13.5\text{ V}$ $R_{SET} = 12\text{ k}\Omega$ $I_{OUTx} \geq 90\%$ of $(k_{LT(typ)}/R_{SET})$

Power Stage

Electrical Characteristics Power Stage (cont'd)

Unless otherwise specified: $V_S = 5.5\text{ V to }18\text{ V}$, $T_j = -40^\circ\text{C to }+150^\circ\text{C}$, $V_{OUTx} = 3.6\text{ V}$, all voltages with respect to ground, positive current flowing into pin for input pins (I), positive currents flowing out of the I/O and output pins (O) (unless otherwise specified)

Pos.	Parameter	Symbol	Limit Values			Unit	Conditions
			Min.	Typ.	Max.		
10.2.8	Maximum output current	$I_{OUT(max)}$	120	–	–	mA	$R_{SET} = 4.7\text{ k}\Omega$ The maximum output current is limited by the thermal conditions. Please refer to Pos. 4.3.1 - Pos. 4.3.3
10.2.9	PWMI turn on time	$t_{ON(PWMI)}$	–	–	15	μs	²⁾ $V_S = 13.5\text{ V}$ $R_{SET} = 12\text{ k}\Omega$ PWMI \rightarrow L $I_{OUTx} = 80\%$ of $(k_{LT(typ)}/R_{SET})$
10.2.10	PWMI turn off time	$t_{OFF(PWMI)}$	–	–	10	μs	²⁾ $V_S = 13.5\text{ V}$ $R_{SET} = 12\text{ k}\Omega$ PWMI \rightarrow H $I_{OUTx} = 20\%$ of $(k_{LT(typ)}/R_{SET})$
10.2.11	ST turn on time	$t_{ON(ST)}$	–	–	15	μs	³⁾ $V_S = 13.5\text{ V}$ $R_{SET} = 12\text{ k}\Omega$ ST \rightarrow L $I_{OUTx} = 80\%$ of $(k_{LT(typ)}/R_{SET})$
10.2.12	ST turn off time	$t_{OFF(ST)}$	–	–	10	μs	³⁾ $V_S = 13.5\text{ V}$ $R_{SET} = 12\text{ k}\Omega$ ST \rightarrow H $I_{OUTx} = 20\%$ of $(k_{LT(typ)}/R_{SET})$
10.2.13	IN_SET turn on time	$t_{ON(IN_SET)}$	–	–	15	μs	$V_S = 13.5\text{ V}$ $I_{IN_SET} = 0 \rightarrow 100\text{ }\mu\text{A}$ $I_{OUTx} = 80\%$ of $(k_{LT(typ)}/R_{SET})$
10.2.14	IN_SET turn off time	$t_{OFF(IN_SET)}$	–	–	10	μs	$V_S = 13.5\text{ V}$ $I_{IN_SET} = 100 \rightarrow 0\text{ }\mu\text{A}$ $I_{OUTx} = 20\%$ of $(k_{LT(typ)}/R_{SET})$
10.2.15	VS turn on time	$t_{ON(VS)}$	–	–	20	μs	^{1) 4)} $V_{EN} = 5.5\text{ V}$ $R_{SET} = 12\text{ k}\Omega$ $V_S = 0 \rightarrow 13.5\text{ V}$ $I_{OUTx} = 80\%$ of $(k_{LT(typ)}/R_{SET})$

Power Stage

Electrical Characteristics Power Stage (cont'd)

Unless otherwise specified: $V_S = 5.5\text{ V to }18\text{ V}$, $T_j = -40^\circ\text{C to }+150^\circ\text{C}$, $V_{\text{OUTx}} = 3.6\text{ V}$, all voltages with respect to ground, positive current flowing into pin for input pins (I), positive currents flowing out of the I/O and output pins (O) (unless otherwise specified)

Pos.	Parameter	Symbol	Limit Values			Unit	Conditions
			Min.	Typ.	Max.		
10.2.16	Current reduction temperature threshold	$T_{j(\text{CRT})}$	–	140	–	°C	¹⁾ $I_{\text{OUTx}} = 95\%$ of $(k_{\text{LT}(\text{typ})}/R_{\text{SET}})$
10.2.17	Output current during current reduction at high temperature	$I_{\text{OUT}(\text{CRT})}$	85% of $(k_{\text{LT}(\text{typ})}/R_{\text{SET}})$	–	–	A	¹⁾ $R_{\text{SET}} = 12\text{ k}\Omega$ $T_j = 150^\circ\text{C}$

- 1) Not subject to production test, specified by design
- 2) see also [Figure 8](#)
- 3) see also [Figure 18](#)
- 4) see also [Figure 6](#)

Application Information

11 Application Information

Note: The following information is given as a hint for the implementation of the device only and shall not be regarded as a description or warranty of a certain functionality, condition or quality of the device.

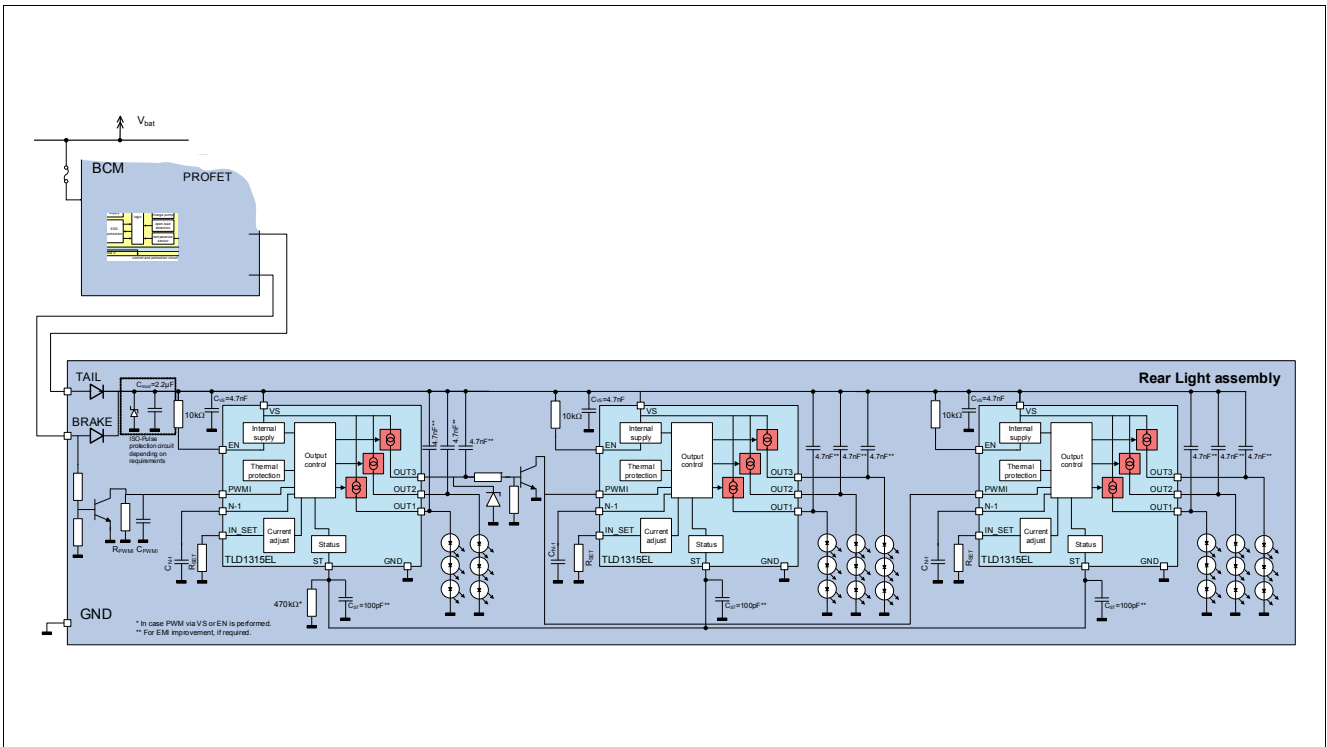

Figure 23 System Diagram PWMI + N-1 detection

Note: This is a very simplified example of an application circuit. In case of high ISO-pulse requirements a reverse protection diode may be used for LED protection. The function must be verified in the real application.

11.1 Further Application Information

- For further information you may contact <http://www.infineon.com/>

12 Package Outlines

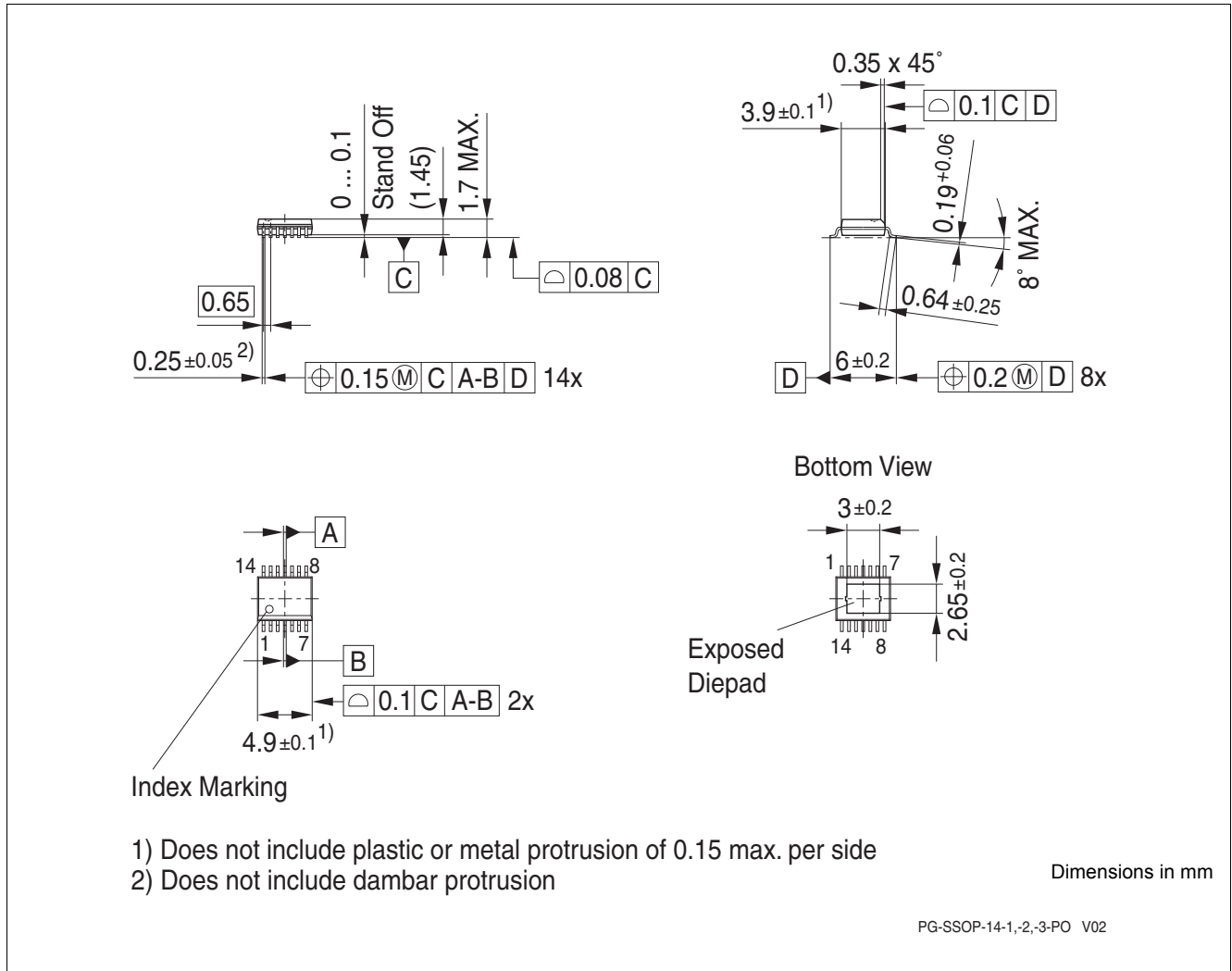

Figure 24 PG-SSOP-14

Green Product (RoHS compliant)

To meet the world-wide customer requirements for environmentally friendly products and to be compliant with government regulations the device is available as a green product. Green products are RoHS-Compliant (i.e Pb-free finish on leads and suitable for Pb-free soldering according to IPC/JEDEC J-STD-020).

For further information on alternative packages, please visit our website:
<http://www.infineon.com/packages>.

Revision History

13 Revision History

Revision	Date	Changes
1.0	2013-08-08	Initial revision of data sheet
1.1	2015-03-19	Updated parameters K_{LT} and K_{ALL} in the chapter Power Stage
1.2	2018-04-26	Updated to latest template
1.2	2018-04-26	Updated application drawing
1.2	2018-04-26	Updated package marking
1.2	2018-04-26	Updated package figure

Table of Contents

1	Overview	1
2	Block Diagram	3
3	Pin Configuration	4
3.1	Pin Assignment	4
3.2	Pin Definitions and Functions	5
4	General Product Characteristics	6
4.1	Absolute Maximum Ratings	6
4.2	Functional Range	7
4.3	Thermal Resistance	7
5	EN Pin	8
5.1	EN Function	8
5.2	Internal Supply Pin	9
5.3	EN Unused	10
5.3.1	EN - Pull Up to VS	10
5.3.2	EN - Direct Connection to VS	10
6	PWMI Pin	11
6.1	PWM Dimming	11
6.2	Internal PWM Unit	12
6.3	Electrical Characteristics Internal Supply / EN / PWMI Pin	14
7	IN_SET Pin	17
7.1	Output Current Adjustment via RSET	17
7.2	Smart Input Pin	17
8	ST Pin	20
8.1	Diagnosis Selector	20
8.2	Diagnosis Output	20
8.3	Disable Input	20
9	Load Diagnosis	22
9.1	N-1 Detection	22
9.2	Double Fault Conditions	25
9.3	Electrical Characteristics IN_SET Pin and Load Diagnosis	25
10	Power Stage	27
10.1	Protection	27
10.1.1	Over Load Behavior	27
10.1.2	Reverse Battery Protection	27
10.2	Electrical Characteristics Power Stage	28
11	Application Information	31
11.1	Further Application Information	31
12	Package Outlines	32
13	Revision History	33
	Table of Contents	34

Trademarks

All referenced product or service names and trademarks are the property of their respective owners.

Edition 2018-04-26

Published by

Infineon Technologies AG

81726 Munich, Germany

© 2018 Infineon Technologies AG.

All Rights Reserved.

Do you have a question about any aspect of this document?

Email: erratum@infineon.com

Document reference

TLD1315EL

IMPORTANT NOTICE

The information given in this document shall in no event be regarded as a guarantee of conditions or characteristics ("Beschaffheitsgarantie").

With respect to any examples, hints or any typical values stated herein and/or any information regarding the application of the product, Infineon Technologies hereby disclaims any and all warranties and liabilities of any kind, including without limitation warranties of non-infringement of intellectual property rights of any third party.

In addition, any information given in this document is subject to customer's compliance with its obligations stated in this document and any applicable legal requirements, norms and standards concerning customer's products and any use of the product of Infineon Technologies in customer's applications.

The data contained in this document is exclusively intended for technically trained staff. It is the responsibility of customer's technical departments to evaluate the suitability of the product for the intended application and the completeness of the product information given in this document with respect to such application.

For further information on technology, delivery terms and conditions and prices, please contact the nearest Infineon Technologies Office (www.infineon.com).

WARNINGS

Due to technical requirements products may contain dangerous substances. For information on the types in question please contact your nearest Infineon Technologies office.

Except as otherwise explicitly approved by Infineon Technologies in a written document signed by authorized representatives of Infineon Technologies, Infineon Technologies' products may not be used in any applications where a failure of the product or any consequences of the use thereof can reasonably be expected to result in personal injury.

Компания «Океан Электроники» предлагает заключение долгосрочных отношений при поставках импортных электронных компонентов на взаимовыгодных условиях!

Наши преимущества:

- Поставка оригинальных импортных электронных компонентов напрямую с производств Америки, Европы и Азии, а так же с крупнейших складов мира;
- Широкая линейка поставок активных и пассивных импортных электронных компонентов (более 30 млн. наименований);
- Поставка сложных, дефицитных, либо снятых с производства позиций;
- Оперативные сроки поставки под заказ (от 5 рабочих дней);
- Экспресс доставка в любую точку России;
- Помощь Конструкторского Отдела и консультации квалифицированных инженеров;
- Техническая поддержка проекта, помощь в подборе аналогов, поставка прототипов;
- Поставка электронных компонентов под контролем ВП;
- Система менеджмента качества сертифицирована по Международному стандарту ISO 9001;
- При необходимости вся продукция военного и аэрокосмического назначения проходит испытания и сертификацию в лаборатории (по согласованию с заказчиком);
- Поставка специализированных компонентов военного и аэрокосмического уровня качества (Xilinx, Altera, Analog Devices, Intersil, Interpoint, Microsemi, Actel, Aeroflex, Peregrine, VPT, Syfer, Eurofarad, Texas Instruments, MS Kennedy, Miteq, Cobham, E2V, MA-COM, Hittite, Mini-Circuits, General Dynamics и др.);

Компания «Океан Электроники» является официальным дистрибьютором и эксклюзивным представителем в России одного из крупнейших производителей разъемов военного и аэрокосмического назначения «JONHON», а так же официальным дистрибьютором и эксклюзивным представителем в России производителя высокотехнологичных и надежных решений для передачи СВЧ сигналов «FORSTAR».



JONHON

«JONHON» (основан в 1970 г.)

Разъемы специального, военного и аэрокосмического назначения:

(Применяются в военной, авиационной, аэрокосмической, морской, железнодорожной, горно- и нефтедобывающей отраслях промышленности)

«FORSTAR» (основан в 1998 г.)

ВЧ соединители, коаксиальные кабели, кабельные сборки и микроволновые компоненты:

(Применяются в телекоммуникациях гражданского и специального назначения, в средствах связи, РЛС, а так же военной, авиационной и аэрокосмической отраслях промышленности).



Телефон: 8 (812) 309-75-97 (многоканальный)

Факс: 8 (812) 320-03-32

Электронная почта: ocean@oceanchips.ru

Web: <http://oceanchips.ru/>

Адрес: 198099, г. Санкт-Петербург, ул. Калинина, д. 2, корп. 4, лит. А