

LTC4088

High Efficiency Battery Charger/Power Manager

DESCRIPTION

Demonstration Circuit 1007 is a high efficiency USB power manager with PowerPath™ control and Li-Ion/Polymer battery charger featuring the LTC®4088. It includes a synchronous switching input regulator, a full featured battery charger and an ideal diode. Designed specifically for USB applications, the LTC4088's switching regulator automatically limits its input current to either 100mA, 500mA or 1A for wall-powered applications via logic control. There are also 2.5mA and 500µA suspend modes to prevent the battery from running down when the product is connected to a suspended USB bus.

The switching input stage provides power to VOUT where power sharing between the application circuit and the battery charger is managed. Unlike linear PowerPath controllers, the LTC4088's switching input stage can use nearly all of the 0.5W or 2.5W available from the USB port with minimal power dissipation. This feature allows the LTC4088 to provide more power to the application and

battery and eases thermal issues in space constrained applications.

An ideal diode ensures that the system power is available from the battery when the input current limit is reached or if the USB or wall supply is removed. The optional external P-channel MOSFET supplements the internal ideal diode by reducing R_{ON} and increasing efficiency.

A CHRG LED indicates four possible states of the battery charger. Charging is indicated when the LED is steady-ON. Not charging is indicated by a steady-OFF. A NTC fault is indicated by a slow blinking rate (1.5Hz) and a bad battery is indicated by a fast blinking rate (6.1Hz).

The LTC4088 is available in the low profile 14-Lead 4mm × 3mm × 0.75mm DFN surface mount package.

Design files for this circuit board are available at <http://www.linear.com/demo/DC1007C>

LT, LT, LTC, LTM, Linear Technology, the Linear logo and PowerPath are registered trademarks of Linear Technology Corporation. All other trademarks are the property of their respective owners.

PERFORMANCE SUMMARY

Specifications are at $T_A = 25^\circ\text{C}$

SYMBOL	PARAMETER	CONDITIONS	MIN	TYP	MAX	UNITS
V_{BUS}	Input Voltage Range		4.35		5.5	V
V_{OUT}		Mode and Load Dependent	3.5		4.7	V
V_{LD03V3}	3.3V	Load and VOUT Dependent		3.3		V
V_{BAT}	Output Float Voltage (Constant Voltage Mode)			4.2		V
I_{BAT}	Output Charge Current (Constant Current Mode)	R_{PROG} Equals 2kΩ		0.5		A

QUICK START PROCEDURE

Demonstration circuit 1007 is best evaluated using a Li-Ion/Polymer battery. When using a battery simulator for evaluation, oscillations must be verified with a real battery at the same conditions because it is difficult to match the impedance of a real battery, which is required for battery charger stability.

Refer to Figure 1 for the proper measurement and equipment setup and follow the procedure below.

1. If using an external supply, connect a 0V to 6V, 1.5A supply with voltage adjusted to 0V between the VBUS and GND terminals. Connect a voltmeter across the VBUS and GND terminals. If using the USB input option, have cable ready to plug in when all loads and jumpers are set. Do *not* use the USB input and an external supply at the same time.
2. Set JP1, NTC jumper to INT to use the demo board resistor. To use an external NTC resistor, connect an NTC resistor between J2 - J3 and the GND terminal. Then set the NTC jumper to EXT.
3. Use Table 1 to set JP2, JP3, and JP4 (D0, D1, and D2 respectively) to select the desired input current limit and charger status.

Table 1. Controlled Input Current Limit

D0	D1	D2	CHARGER	I _{LIM}
0	0	0	ON	100mA (1x)
0	0	1	OFF	100mA (1x)
0	1	0	ON	500mA (5x)
0	1	1	OFF	500mA (5x)
1	0	0	ON	1A (10x)
1	0	1	OFF	1A (10x)
1	1	0	OFF	500µA (SUSP)
1	1	1	OFF	2.5mA (SUSP)

4. Connect a 0mA to 25mA adjustable load in series with an ammeter between the 3.3V and GND terminals. Connect a voltmeter between the 3.3V and GND terminals.
5. Connect a 0A to 2A adjustable load in series with an ammeter between the VOUT terminal and the GND terminal. Connect a voltmeter between the VOUT and GND terminals.
6. Connect a partially charged (~3.6V) lithium-ion battery with the positive lead to the BAT terminal and the negative lead to a GND terminal. Connect the positive lead of a voltmeter to the BAT terminal and the negative lead to the GND terminal. Connect the positive terminal of a voltmeter to PROG and the negative terminal to GND to measure the current flowing into the battery. The voltage on PROG will read 1V when the maximum charge current is reached. The voltage on CLPROG will read 1.188V when the input current is reached. Observe VOUT and the 3.3V output.

$$I_{BAT} = \frac{V_{PROG}}{R_{PROG}} \cdot 1031$$

$$I_{VBUS} = I_{BUSQ} + \frac{V_{CLPROG}}{R_{CLPROG}} \cdot (h_{CLPROG} + 1)$$

See the data sheet for the proper values of I_{BUSQ} and h_{CLPROG} in the 1x, 5x and 10x modes.

7. If using the USB input, plug in the USB cable and observe the charge current, VOUT, and the 3.3V output. If using an external power supply, slowly increase the supply and observe that the LTC4088 starts to use the VBUS input power as the VBUS reaches 4.35V.

QUICK START PROCEDURE

8. Discharge the battery to 2.5V. If charger mode is on, observe it is charging in trickle charge mode and the charge current is 50mA. As the battery voltage increases above 2.85V observe that the charger goes into full constant current mode. Observe that VOUT stays above 3.6V when the input current limit is not exceeded. Remove the NTC jumper on JP2. Observe the CHRG LED slow blinking rate. Also observe the 35KHz pulse with varying duty cycle between 4.7% and 95.3% on the CHRG terminal with an oscilloscope. Reinstall the NTC jumper.
 9. Increase the VOUT load and observe when the input current starts to limit ($V_{CLPROG} = 1.188V$). When input current limit is reached, VOUT drops from 300mV above the BAT voltage to 15mV below the BAT voltage and the additional load transitions to the battery through the ideal diode. Due to the high efficiency of the switching regulator, the charge and load current may be significantly above the input current depending on the voltage on the BAT pin.
 10. Repeat step 9 with different current limit modes.
 11. Set the VBUS input supply to 5V. Observe the battery current as the battery voltage increases above 4.1V. The charge current starts to decrease as the battery voltage increases towards 4.2V.
- See the latest LTC4088 data sheet for more information on how this part performs.

APPLICATION INFORMATION

This demo circuit is designed to demonstrate the full capability of the LTC4088 high efficiency battery charger. Not all components are required in all applications. The critical circuit components are on the top of the board near the IC and listed in the Required Circuit Components section of the Parts List

The input capacitor network of C7 and R13 is used to dampen source lead inductances that commonly occur in laboratory setups with twisted leads and a bench power supply. When using an USB cable or adaptor cable this input damping network will likely not be required. Please note that the in-circuit capacitance of the specified 10 μ F, 0805 ceramic capacitor for C2 and C7 is approximately 5 μ F each at a VBUS greater than 4.25V.

Capacitor C4 is only required when using the 10 \times mode. The LTC4088 requires a minimum of 10 μ F on the OUT pin in 10 \times mode for voltage loop stability. As an alternative to using two smaller X5R capacitors, one larger X5R ceramic capacitor would be acceptable, provided that the actual in-circuit capacitance with 4.2V applied is greater than 10 μ F.

Capacitor C5 is included to simulate a low impedance battery. It is especially helpful when testing the demo circuit with a battery simulator comprised of a standard power supply with a 3.6 Ω power resistor across it. The leads connecting the power supply to the demo circuit should be a twisted pair to minimize lead inductance; although, even twisted pairs can introduce enough inductance into the circuit to cause instability in the battery charger section without the presence of C5. Capacitor C5 will also provide proper operation of the circuit without a battery present. Refer to the data sheet for more discussion of operation without a battery. If desired, it is possible to use a ceramic capacitor in series with a low valued resistor to stabilize the battery charger when no battery is present. Please refer to the data sheet for the suggested capacitor and resistance range.

When not using the 3.3V LDO (LDO3V3) connect VOUT to LDO3V3 by installing R12 and removing C1.

APPLICATION INFORMATION

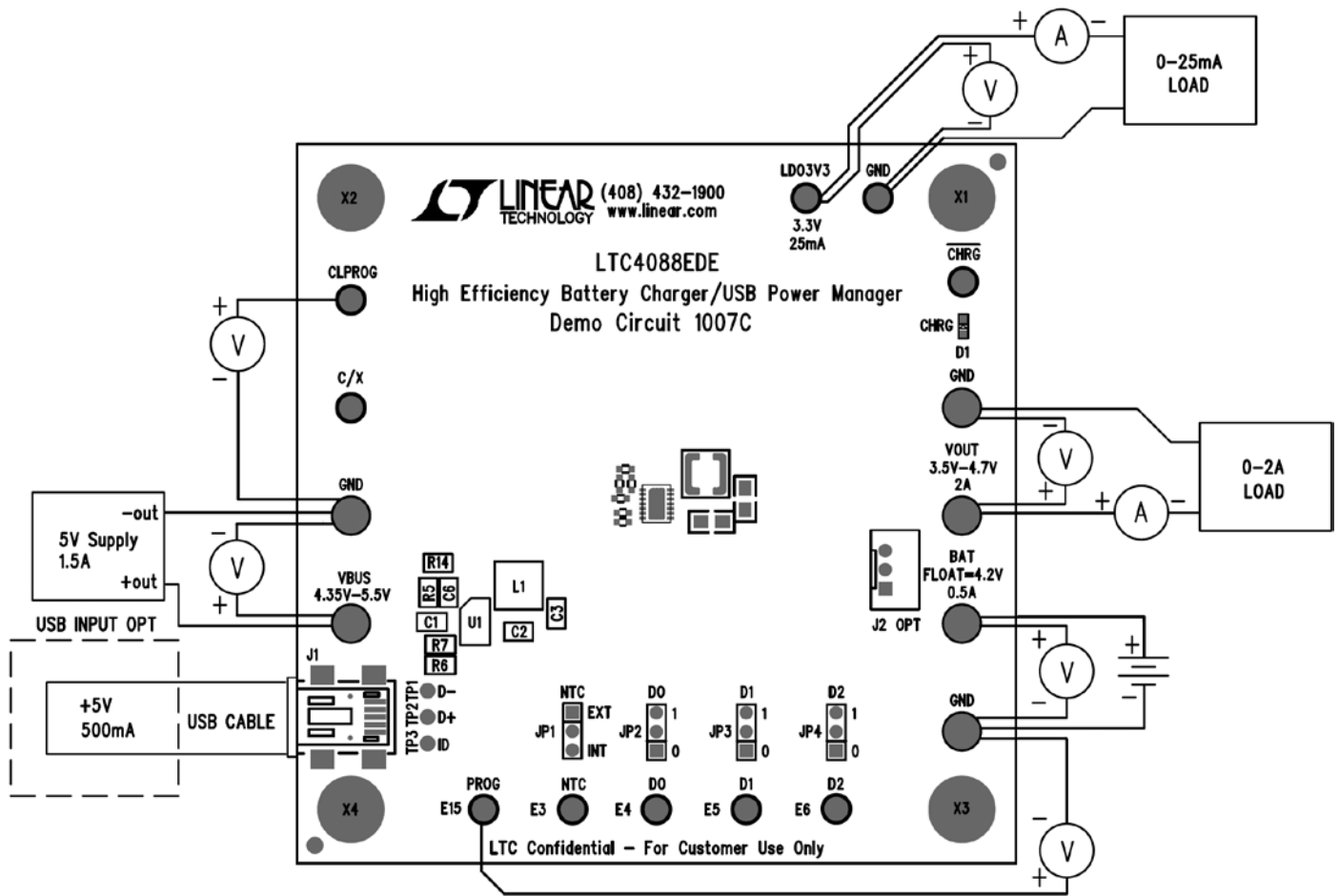

Figure 1. Proper Measurement Equipment Setup for DC1007C

DEMO MANUAL DC1007C

PARTS LIST

ITEM	QTY	REFERENCE	PART DESCRIPTION	MANUFACTURER/PART NUMBER
Required Circuit Components				
1	1	C1	CAP, CHIP, X5R, 1.0 μ F, 6.3V, 0402	MURATA, GRM155R60J105ME19D
2	1	C2	CAP, CHIP, X5R, 10 μ F, 10V, 0805	MURATA, GRM21BR61A106KE19L
3	1	C3	CAP, CHIP, X5R, 22 μ F, 6.3V, 0805	MURATA, GRM21BR60J226ME39L
4	1	C6	CAP, CHIP, X7R, 0.1 μ F, 16V, 0402	MURATA, GRM155R71C104KA88D
5	1	L1	IND, 3.3 μ H, 0.08 Ω , 2.2A	COILCRAFT, LPS4018-332MRC
6	1	R5	RES, 0402 2.94k 1% 1/16W	VISHAY, CRCW04022K94FKED
7	2	R6, R7	RES, 0402 2k 1% 1/16W	VISHAY, CRCW04022K00FKED
8	1	R14	RES, 0402 8R 25 Ω 1% 1/16W	VISHAY, CRCW04028R25FNED
9	1	U1	IC, USB BAT CHARGER/POWER MANAGER, DFN-14	LTC4088EDE
Additional Demo Board Circuit Components				
10	1	C4	CAP, CHIP, X5R, 22 μ F, 6.3V, 0805	MURATA, GRM155R60J105ME19D
11	1	C5	CAP, CHIP OS-CON, 100 μ F, 6.3V, B6	PANASONIC, 6SVPC100MY
12	1	C7	CAP, CHIP, X5R, 10 μ F, 10V, 0805	MURATA, GRM21BR61A106KE19L
13	1	D1	LED 565NM GRN DIFF 0603 SMD	LUMEX OPTO/COMPONENTS INC, SML-LX0603GW-TR
14	1	Q1	XSTR, MOSFET P-CHANNEL	SILICONIX, Si2333DDS
15	2	R1, R2	RES, 0402, 100k, 1%, 1/16W	VISHAY, CRCW0402100KFKED
16	4	R3, R4, R8, R9	RES, 0402 0R 0 Ω 1/16W	VISHAY CRCW04020000Z0ED
17	1	R10	RES, 0402 510 Ω 1% 1/10W	VISHAY CRCW0402 5100 1%
18	0	R11 (OPT)	RES., OPTION, 0402	OPT
19	0	R12 (OPT)	RES, 0402 0R 0 Ω 1/16W	VISHAY CRCW04020000Z0ED
20	1	R13	RES., 1 Ω , 1%, 1/16W, 0402	VISHAY, CRCW04021R00FKED
Hardware: For Demo Board Only				
21	1	J1	CONN, USB MINI-B	TYCO 440247-1
22	6	E1, E2, E8, E9, E10, E11	TEST POINT, TURRET, 0.094", MTG. HOLE	MILL-MAX, 2501-2-00-80-00-00-07-0
23	10	E3, E4, E5, E6, E7, E12, E13, E14, E15, E16	TEST POINT, TURRET, 0.064", MTG. HOLE	MILL-MAX, 2308-2-00-80-00-00-07-0
24	4	JP1, JP2, JP3, JP4	HEADER, 3 PINS 2mm	COMM 2802S-03G2
25	4		STANDOFFS	KEYSTONE, 8831

SCHEMATIC DIAGRAM

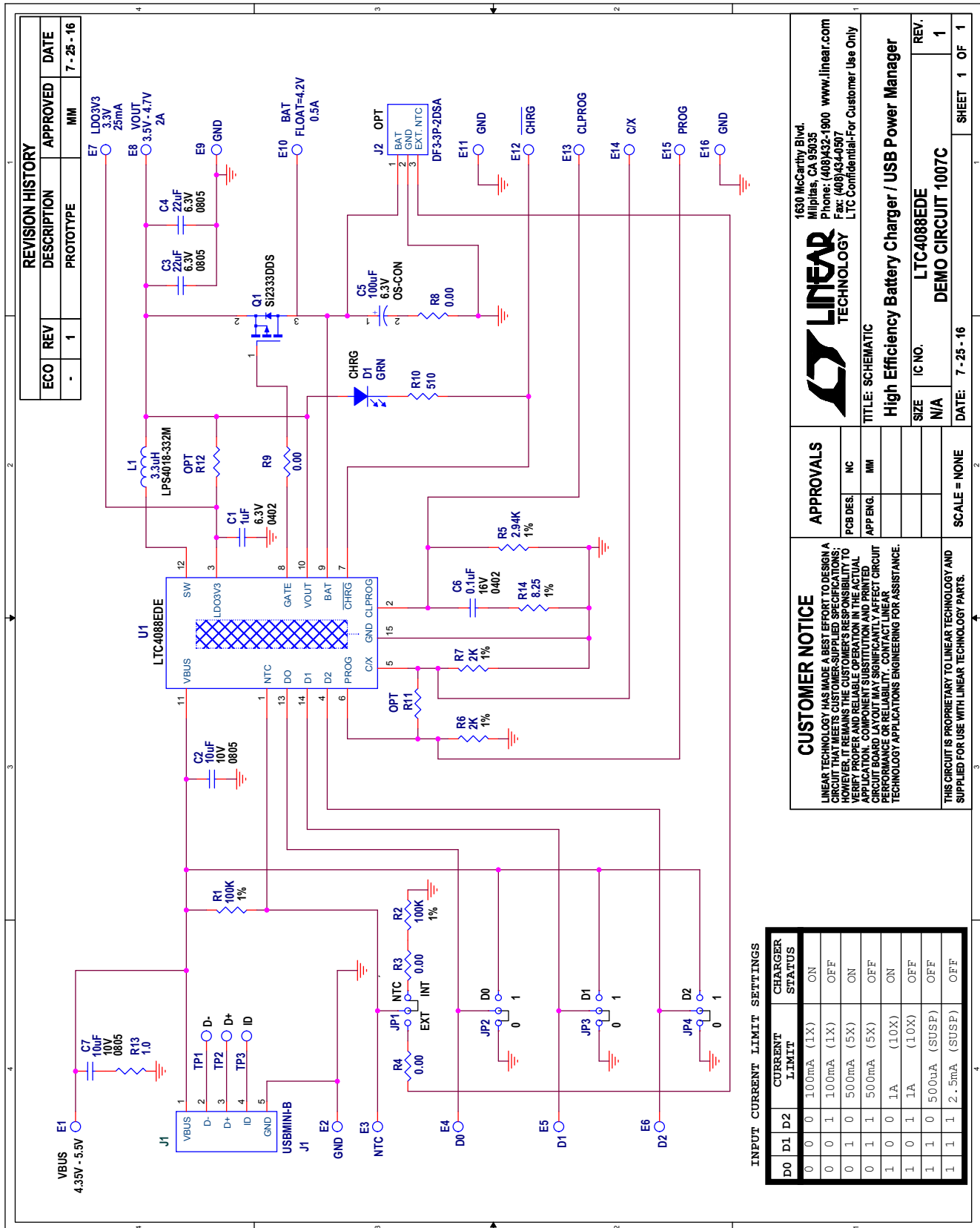

DEMO MANUAL DC1007C

DEMONSTRATION BOARD IMPORTANT NOTICE

Linear Technology Corporation (LTC) provides the enclosed product(s) under the following **AS IS** conditions:

This demonstration board (DEMO BOARD) kit being sold or provided by Linear Technology is intended for use for **ENGINEERING DEVELOPMENT OR EVALUATION PURPOSES ONLY** and is not provided by LTC for commercial use. As such, the DEMO BOARD herein may not be complete in terms of required design-, marketing-, and/or manufacturing-related protective considerations, including but not limited to product safety measures typically found in finished commercial goods. As a prototype, this product does not fall within the scope of the European Union directive on electromagnetic compatibility and therefore may or may not meet the technical requirements of the directive, or other regulations.

If this evaluation kit does not meet the specifications recited in the DEMO BOARD manual the kit may be returned within 30 days from the date of delivery for a full refund. **THE FOREGOING WARRANTY IS THE EXCLUSIVE WARRANTY MADE BY THE SELLER TO BUYER AND IS IN LIEU OF ALL OTHER WARRANTIES, EXPRESSED, IMPLIED, OR STATUTORY, INCLUDING ANY WARRANTY OF MERCHANTABILITY OR FITNESS FOR ANY PARTICULAR PURPOSE. EXCEPT TO THE EXTENT OF THIS INDEMNITY, NEITHER PARTY SHALL BE LIABLE TO THE OTHER FOR ANY INDIRECT, SPECIAL, INCIDENTAL, OR CONSEQUENTIAL DAMAGES.**

The user assumes all responsibility and liability for proper and safe handling of the goods. Further, the user releases LTC from all claims arising from the handling or use of the goods. Due to the open construction of the product, it is the user's responsibility to take any and all appropriate precautions with regard to electrostatic discharge. Also be aware that the products herein may not be regulatory compliant or agency certified (FCC, UL, CE, etc.).

No License is granted under any patent right or other intellectual property whatsoever. **LTC assumes no liability for applications assistance, customer product design, software performance, or infringement of patents or any other intellectual property rights of any kind.**

LTC currently services a variety of customers for products around the world, and therefore this transaction **is not exclusive**.

Please read the DEMO BOARD manual prior to handling the product. Persons handling this product must have electronics training and observe good laboratory practice standards. **Common sense is encouraged.**

This notice contains important safety information about temperatures and voltages. For further safety concerns, please contact a LTC application engineer.

Mailing Address:

Linear Technology
1630 McCarthy Blvd.
Milpitas, CA 95035

Copyright © 2004, Linear Technology Corporation

Компания «Океан Электроники» предлагает заключение долгосрочных отношений при поставках импортных электронных компонентов на взаимовыгодных условиях!

Наши преимущества:

- Поставка оригинальных импортных электронных компонентов напрямую с производств Америки, Европы и Азии, а так же с крупнейших складов мира;
- Широкая линейка поставок активных и пассивных импортных электронных компонентов (более 30 млн. наименований);
- Поставка сложных, дефицитных, либо снятых с производства позиций;
- Оперативные сроки поставки под заказ (от 5 рабочих дней);
- Экспресс доставка в любую точку России;
- Помощь Конструкторского Отдела и консультации квалифицированных инженеров;
- Техническая поддержка проекта, помощь в подборе аналогов, поставка прототипов;
- Поставка электронных компонентов под контролем ВП;
- Система менеджмента качества сертифицирована по Международному стандарту ISO 9001;
- При необходимости вся продукция военного и аэрокосмического назначения проходит испытания и сертификацию в лаборатории (по согласованию с заказчиком);
- Поставка специализированных компонентов военного и аэрокосмического уровня качества (Xilinx, Altera, Analog Devices, Intersil, Interpoint, Microsemi, Actel, Aeroflex, Peregrine, VPT, Syfer, Eurofarad, Texas Instruments, MS Kennedy, Miteq, Cobham, E2V, MA-COM, Hittite, Mini-Circuits, General Dynamics и др.);

Компания «Океан Электроники» является официальным дистрибьютором и эксклюзивным представителем в России одного из крупнейших производителей разъемов военного и аэрокосмического назначения «JONHON», а так же официальным дистрибьютором и эксклюзивным представителем в России производителя высокотехнологичных и надежных решений для передачи СВЧ сигналов «FORSTAR».



JONHON

«JONHON» (основан в 1970 г.)

Разъемы специального, военного и аэрокосмического назначения:

(Применяются в военной, авиационной, аэрокосмической, морской, железнодорожной, горно- и нефтедобывающей отраслях промышленности)

«FORSTAR» (основан в 1998 г.)

ВЧ соединители, коаксиальные кабели, кабельные сборки и микроволновые компоненты:

(Применяются в телекоммуникациях гражданского и специального назначения, в средствах связи, РЛС, а так же военной, авиационной и аэрокосмической отраслях промышленности).



Телефон: 8 (812) 309-75-97 (многоканальный)

Факс: 8 (812) 320-03-32

Электронная почта: ocean@oceanchips.ru

Web: <http://oceanchips.ru/>

Адрес: 198099, г. Санкт-Петербург, ул. Калинина, д. 2, корп. 4, лит. А