

Features

- High FSK sensitivity: -105.5dBm at 20Kbit/s / -109dBm at 2.4Kbit/s (433.92MHz)
- High ASK sensitivity: -111.5dBm at 10Kbit/s / -116dBm at 2.4Kbit/s (100% ASK, carrier level 433.92MHz)
- Low supply current: 10.5mA in RX and TX mode ($3\text{V}/\text{TX}$ with $5\text{dBm}/433.92\text{MHz}$)
- Data rate 1 to 20Kbit/s Manchester FSK, 1 to 10Kbit/s Manchester ASK
- ASK/FSK receiver uses a low IF architecture with high selectivity, blocking and low intermodulation (typical 3dB blocking 55.5dBC at $\pm 750\text{kHz}/60.5\text{dBC}$ at $\pm 1.5\text{MHz}$ and 67dBC at $\pm 10\text{MHz}$, system $11\text{dBCP} = -30\text{dBm}/\text{system IIP3} = -20\text{dBm}$)
- Wide bandwidth AGC to handle large outband blockers above the system 11dBCP
- 226kHz IF (intermediate frequency) with 30dB image rejection and 220kHz system bandwidth to support TPM transmitters using Atmel® ATA5756/ATA5757 transmitters with standard crystals
- Transmitter uses closed loop FSK modulation with fractional-N synthesizer with high PLL bandwidth and an excellent isolation between PLL and PA
- Tolerances of XTAL compensated by fractional-N synthesizer with 800Hz RF resolution
- Integrated RX/TX-switch, single-ended RF input and output
- RSSI (received signal strength indicator)
- Communication to microcontroller with SPI interface working at 500Kbit/s maximum
- Configurable self polling and RX/TX protocol handling with FIFO-RAM buffering of received and transmitted data
- 1 push button input and 1 wake-up input are active in power-down mode
- Integrated XTAL capacitors
- PA efficiency: up to 38% ($433.92\text{MHz}/10\text{dBm}/3\text{V}$)
- Low In-band sensitivity change of typically $\pm 2.0\text{dB}$ within $\pm 75\text{kHz}$ center frequency change in the complete temperature and supply voltage range

- Fully integrated PLL with low phase noise VCO, PLL loop filter and full support of multi-channel operation with arbitrary channel distance due to fractional-N synthesizer
- Sophisticated threshold control and quasi-peak detector circuit in the data slicer
- 433.92MHz, and 315MHz without external VCO and PLL components
- Efficient XTO start-up circuit ($> -1.5k\Omega$ worst case start impedance)
- Changing of modulation type ASK/FSK and data rate without component changes to allow different modulation schemes in TPM and RKE
- Minimal external circuitry requirements for complete system solution
- Adjustable output power: 0 to 10dBm adjusted and stabilized with external resistor, programmable output power with 0.5dB steps with internal resistor
- Clock and interrupt generation for microcontroller
- ESD protection at all pins ($\pm 2.5kV$ HBM, $\pm 200V$ MM, $\pm 500V$ FCDM)
- Supply voltage range: 2.15V to 3.6V or 4.4V to 5.25V
- Typical power-down current $< 10nA$
- Temperature range: $-40^{\circ}C$ to $+105^{\circ}C$
- Small 7mm \times 7mm QFN48 package

Applications

- Automotive keyless entry and passive entry go (handsfree car access)
- Tire pressure monitoring systems
- Remote control systems
- Alarm and telemetering systems
- Energy metering
- Home automation

Benefits

- No SAW device needed in key fob designs to meet automotive specifications
- Low system cost due to very high system integration level
- Only one crystal needed in system
- Less demanding specification for the microcontroller due to handling of power-down mode, delivering of clock and complete handling of receive/transmit protocol and polling
- Single-ended design with high isolation of PLL/VCO from PA and the power supply allows a loop antenna in the key fob to surround the whole application
- Integration of tire pressure monitoring, passive entry and remote keyless entry

1. General Description

The Atmel® ATA5823/ATA5824 is a highly integrated UHF ASK/FSK multi-channel half-duplex transceiver with low power consumption supplied in a small 7mm × 7mm QFN48 package. The receive part is built as a fully integrated low-IF receiver, whereas direct PLL modulation with the fractional-N synthesizer is used for FSK transmission and switching of the power amplifier for ASK transmission.

The device supports data rates of 1Kbit/s to 20Kbit/s (FSK) and 1Kbit/s to 10Kbit/s (ASK) in Manchester, Bi-phase and other codes in transparent mode. The Atmel ATA5824 can be used in the 433MHz to 435MHz band and the Atmel ATA5823 in the 313MHz to 316MHz band. The very high system integration level results in few numbers of external components needed.

Due to its blocking and selectivity performance, together with a typical narrow-band key-fob loop antenna with 15dB to 20dB loss, a bulky blocking SAW is not needed in the key fob application. Additionally, the building blocks needed for a typical RKE and access control system on both sides, the base and the mobile stations, are fully integrated.

Its digital control logic with self polling and protocol generation provides a fast challenge response system without using a high-performance microcontroller. Therefore, the Atmel ATA5823/ATA5824 contains a FIFO buffer RAM and can compose and receive the physical messages themselves. This provides more time for the microcontroller to carry out other functions such as calculating crypto algorithms, composing the logical messages and controlling other devices. Due to that, a standard 4-/8-bit microcontroller without special periphery and clocked with the delivered CLK output of about 4.5MHz is sufficient to control the communication link. This is especially valid for passive entry go and access control systems, where within less than 100 ms several communication responses with arbitration of the communication partner have to be handled. It is hence possible to design bi-directional RKE and passive entry go systems with a fast challenge response crypto function and prevention against relay attacks.

Figure 1-1. System Block Diagram

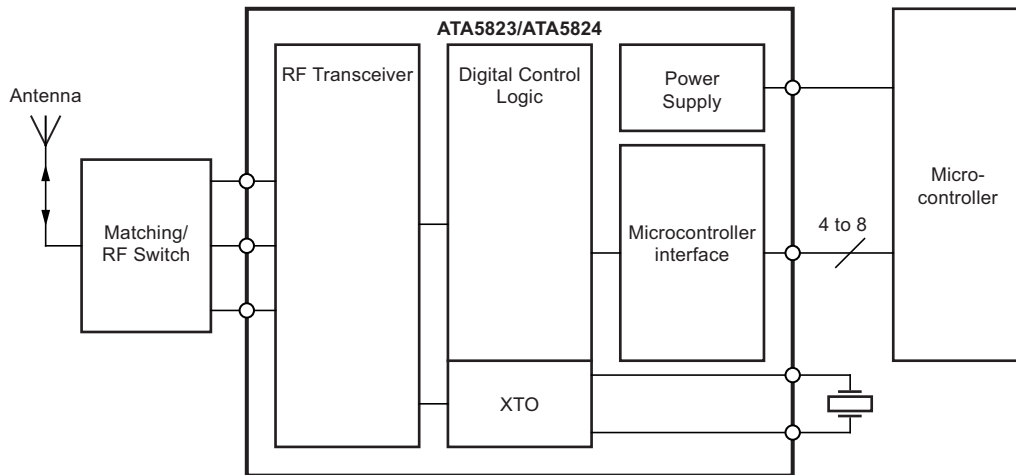

2. Pin Configuration

Figure 2-1. Pinning QFN48

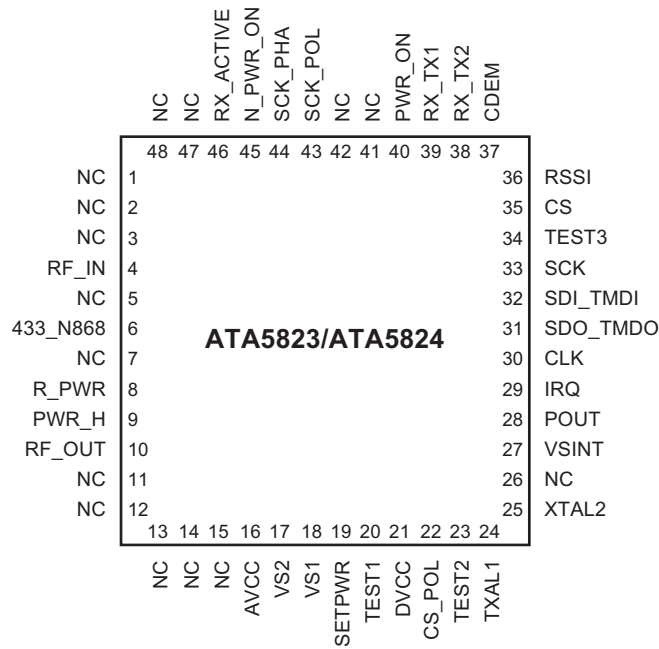

Table 2-1. Pin Description

Pin	Symbol	Function
1	NC	Not connected
2	NC	Not connected
3	NC	Not connected
4	RF_IN	RF input
5	NC	Not connected
6	433_N868	Selects RF input/output frequency range
7	NC	Not connected
8	R_PWR	Resistor to adjust output power
9	PWR_H	Pin to select output power
10	RF_OUT	RF output
11	NC	Not connected
12	NC	Not connected
13	NC	Not connected
14	NC	Not connected
15	NC	Not connected
16	AVCC	Blocking of the analog voltage supply
17	VS2	Power supply input for voltage range 4.4V to 5.6V
18	VS1	Power supply input for voltage range 2.15V to 3.6V
19	SETPWR	Internal Programmable Resistor to adjust output power
20	TEST1	Test input, at GND during operation
21	DVCC	Blocking of the digital voltage supply

Table 2-1. Pin Description (Continued)

Pin	Symbol	Function
22	CS_POL	Select polarity of pin CS
23	TEST2	Test input, at GND during operation
24	XTAL1	Reference crystal
25	XTAL2	Reference crystal
26	NC	Not connected
27	VSINT	Microcontroller interface supply voltage
28	POUT	Programmable output
29	IRQ	Interrupt request
30	CLK	Clock output to connect a microcontroller
31	SDO_TMDO	Serial data out/transparent mode data out
32	SDI_TMDI	Serial data in/transparent mode data in
33	SCK	Serial clock
34	TEST3	Test output open during operation
35	CS	Chip select for serial interface
36	RSSI	Output of the RSSI amplifier
37	CDEM	Capacitor to adjust the lower cut-off frequency data filter
38	RX_TX2	Has to be connected GND
39	RX_TX1	Switch pin to decouple LNA in TX mode (RKE mode)
40	PWR_ON	Input to switch on the system (active high)
41	NC	Not connected
42	NC	Not connected
43	SCK_POL	Polarity of the serial clock
44	SCK_PHA	Phase of the serial clock
45	N_PWR_ON	Keyboard input (can also be used to switch on the system, active low)
46	RX_ACTIVE	Indicates RX operation mode
47	NC	Not connected
48	NC	Not connected
	GND	Ground/Backplane (exposed die pad)

Figure 2-2. Block Diagram

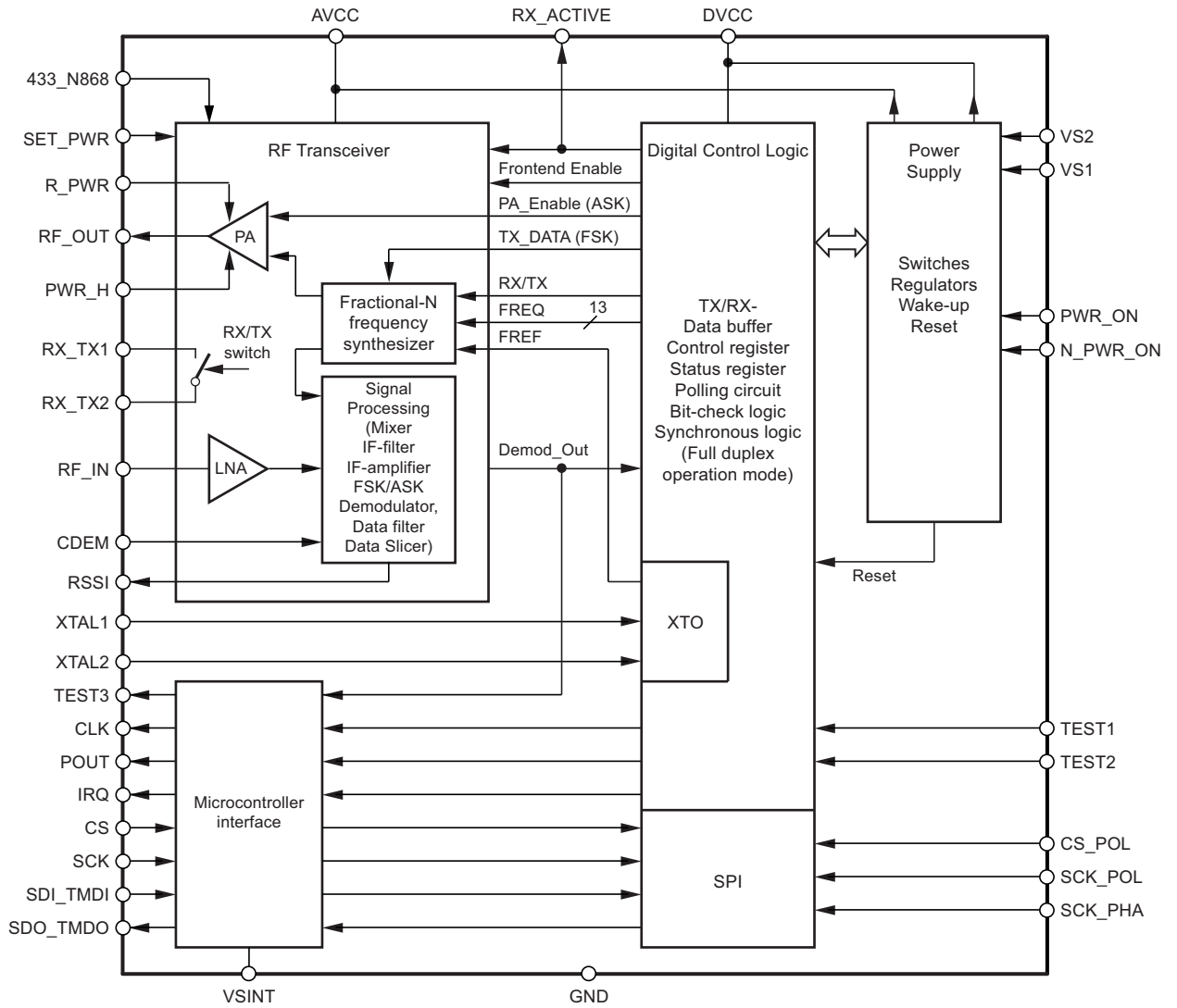

3. Typical Key Fob Application for Bi-directional RKE

Figure 3-1. Typical Key Fob Application for Bi-directional RKE with 5dBm TX Power, 433.92MHz

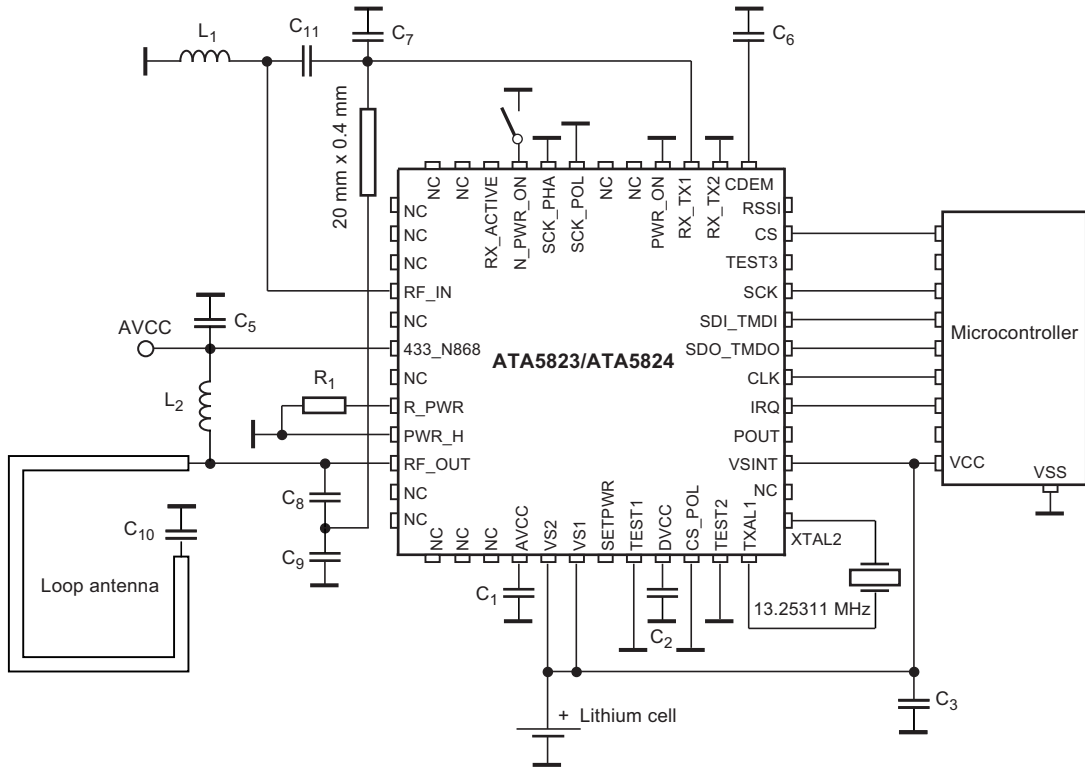

Figure 3-1 shows a typical 433.92MHz RKE key fob application. The external components are 10 capacitors, 1 resistor, 2 inductors and a crystal. C_1 to C_3 are 68nF voltage supply blocking capacitors. C_5 is a 10nF supply blocking capacitor. C_6 is a 15nF fixed capacitor used for the internal quasi-peak detector and for the high-pass frequency of the data filter. C_7 to C_{11} are RF matching capacitors in the range of 1pF to 33pF. L_1 is a matching inductor of about 5.6nH to 56nH. L_2 is a feed inductor of about 120nH. A load capacitor of 9pF for the crystal is integrated. R_1 is typically 22k Ω and sets the output power to about 5.5dBm. The loop antenna's quality factor is somewhat reduced by this application due to the quality factor of L_2 and the RX/TX switch. On the other hand, this lower quality factor is necessary to have a robust design with a bandwidth that is wide enough for production tolerances. Due to the single-ended and ground-referenced design, the loop antenna can be a free-form wire around the application as it is usually employed in RKE unidirectional systems. The Atmel[®] ATA5823/ATA5824 provides sufficient isolation and robust pulling behavior of internal circuits from the supply voltage as well as an integrated VCO inductor to allow this. Since the efficiency of a loop antenna is proportional to the square of the surrounded area, it is beneficial to have a large loop around the application board with a lower quality factor to relax the tolerance specification of the RF matching components and to get a high antenna efficiency in spite of their lower quality factor.

4. Typical Car Application for Bi-directional RKE

Figure 4-1. Typical Car Application for Bi-directional RKE with 10dBm TX Power, 433.92MHz

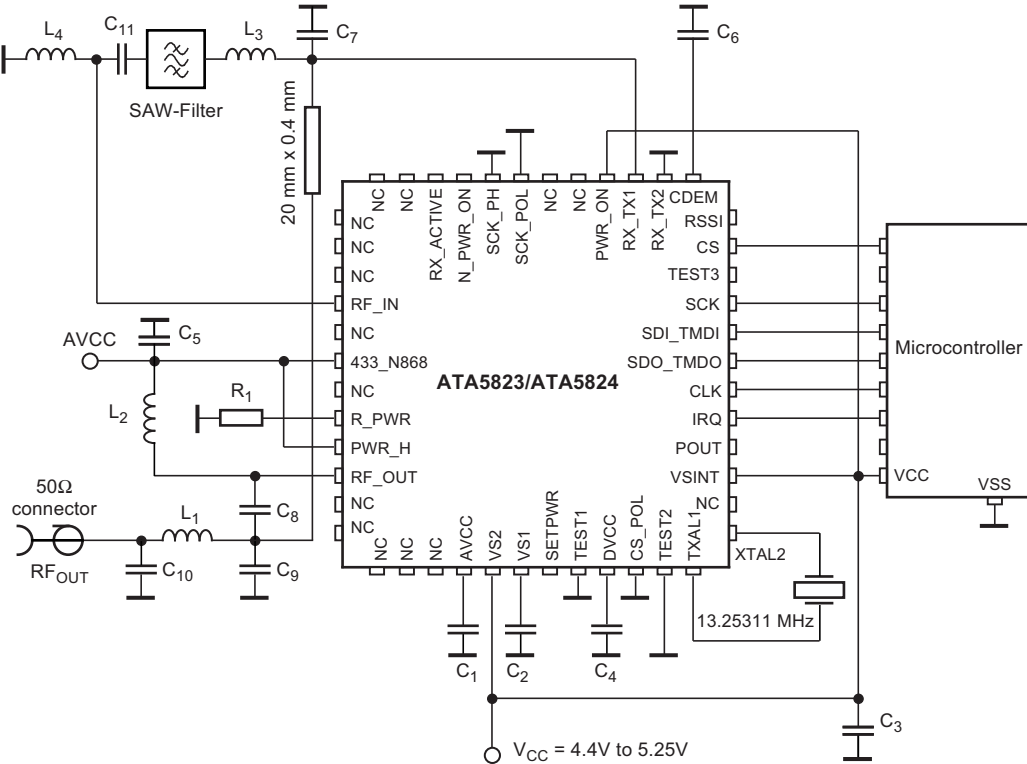

Figure 4-1 shows a typical 433.92MHz $V_{CC} = 4.4V$ to $5.25V$ RKE car application. The external components are 11 capacitors, 1 resistor, 4 inductors, a SAW filter and a crystal. C_1 , C_3 and C_4 are 68nF voltage supply blocking capacitors. C_2 is a 2.2 μ F supply blocking capacitor for the internal voltage regulator. C_5 is a 10nF supply blocking capacitor. C_6 is a 15nF fixed capacitor used for the internal quasi-peak detector and for the high-pass frequency of the data filter. C_7 to C_{11} are RF matching capacitors in the range of 1pF to 33pF. L_2 to L_4 are matching inductors of about 5.6nH to 56nH. A load capacitor for the crystal of 9pF is integrated. R_1 is typically 22k Ω and sets the output power at RF_{OUT} to about 10dBm. Since a quarter wave or PCB antenna, which has high efficiency and wideband operation, is typically used here, it is recommended to use a SAW filter to achieve high sensitivity in case of powerful out-of-band blockers. L_1 , C_{10} and C_9 together form a low-pass filter, which is needed to filter out the harmonics in the transmitted signal to meet regulations.

5. RF Transceiver in Half-duplex Mode

According to [Figure 2-2 on page 6](#), the RF transceiver consists of an LNA (Low-Noise Amplifier), PA (Power Amplifier), RX/TX switch, fractional-N frequency synthesizer and the signal processing part with mixer, IF filter, IF amplifier with analog RSSI, FSK/ASK demodulator, data filter and data slicer.

In receive mode the LNA pre-amplifies the received signal which is converted down to 226kHz intermediate frequency (IF), filtered and amplified before it is fed into an FSK/ASK demodulator, data filter and data slicer. The RSSI (Received Signal Strength Indicator) signal and the raw digital output signal of the demodulator are available at the pins RSSI and on TEST3 (open drain output). The demodulated data signal Demod_Out is fed into the digital control logic where it is evaluated and buffered as described in section [“Digital Control Logic” on page 32](#).

In transmit mode the fractional-N frequency synthesizer generates the TX frequency which is fed into the PA. In ASK mode the PA is modulated by the signal PA_Enable. In FSK mode the PA is enabled and the signal TX_DATA (FSK) modulates the fractional-N frequency synthesizer. The frequency deviation is digitally controlled and internally fixed to about $\pm 19.5\text{kHz}$ (see [Table 6-1 on page 25](#) for exact values). The transmit data can also be buffered as described in section [“Digital Control Logic” on page 32](#). A lock detector within the synthesizer ensures that the transmission will only start if the synthesizer is locked.

In half-duplex mode the RX/TX switch can be used to combine the LNA input and the PA output to a single antenna with a minimum of losses.

Transparent modes without buffering of RX and TX data are also available to allow protocols and coding schemes other than the internal supported Manchester encoding, like PWM and pulse position coding.

5.1 Low-IF Receiver

The receive path consists of a fully integrated low-IF receiver. It fulfills the sensitivity, blocking, selectivity, supply voltage and supply current specification needed to manufacture an automotive key fob for RKE and PEG systems without the use of a SAW blocking filter (see [Figure 3-1 on page 7](#)). The receiver can be connected to the roof antenna in the car when using an additional blocking SAW front-end filter as shown in [Figure 4-1 on page 8](#).

At 433.92MHz the receiver has a typical system noise figure of 6.5dB, a system I1dB_{CP} of -30dBm and a system IIP3 of -20dBm . The signal path is linear for disturbers up to the I1dB_{CP} and there is hence no AGC or switching of the LNA needed to achieve a better blocking performance. This receiver uses an IF of about 226kHz (see [Section 14. “Electrical Characteristics: General” on page 61](#) number 2.10 for exact values), the typical image rejection is 30dB and the typical 3dB system bandwidth is 220kHz ($f_{\text{IF}} = 226\text{kHz} \pm 110\text{kHz}$, $f_{\text{lo_IF}} = 116\text{kHz}$ and $f_{\text{hi_IF}} = 336\text{kHz}$). The demodulator needs a signal to noise ratio of 8dB for 20Kbit/s Manchester with $\pm 19.5\text{kHz}$ frequency deviation in FSK mode, thus, the resulting sensitivity at 433.92MHz is typically -105.5dBm .

Due to the low phase noise and spurious of the synthesizer in receive mode⁽¹⁾ together with the eighth order integrated IF filter the receiver has a better selectivity and blocking performance than more complex double superhet receivers, without using external components and without numerous spurious receiving frequencies.

Note: 1. -120dBC/Hz at $\pm 1\text{MHz}$ and -72dBC at $\pm f_{\text{XTO}}$ at 433.92MHz

A low-IF architecture is also less sensitive to second-order intermodulation (IIP2) than direct conversion receivers where every pulse or amplitude modulated signal (especially the signals from TDMA systems like GSM) demodulates to the receiving signal band at second-order non-linearities.

5.2 Input Matching at RF_IN

The measured input impedances as well as the values of a parallel equivalent circuit of these impedances can be seen in [Table 5-1](#). The highest sensitivity is achieved with power matching of these impedances to the source impedance of 50Ω.

Table 5-1. Measured Input Impedances of the RF_IN Pin

f_{RF}/MHz	$Z_{in}(\text{RF_IN})$	R_{in_p}/C_{in_p}
315	$(44-j233)\Omega$	$1278\Omega/2.1\text{pF}$
433.92	$(32-j169)\Omega$	$925\Omega/2.1\text{pF}$

The matching of the LNA Input to 50Ω was done with the circuit according to [Figure 5-1](#) and with the values of the matching elements given in [Table 5-2](#). The reflection coefficients were always $\leq -10\text{dB}$. Note that value changes of C_1 and L_1 may be necessary to compensate individual board layout parasitics. The measured typical FSK and ASK Manchester code sensitivities with a Bit Error Rate (BER) of 10^{-3} are shown in [Table 5-3 on page 10](#) and [Table 5-4 on page 10](#). These measurements were done with multilayer inductors having quality factors according to [Table 5-2](#), resulting in estimated matching losses of 0.8dB at 315MHz and 0.8dB at 433.92MHz. These losses can be estimated when calculating the parallel equivalent resistance of the inductor with $R_{loss} = 2 \times \pi \times f \times L \times Q_L$ and the matching loss with $10 \log(1+R_{in_p}/R_{loss})$.

With an ideal inductor, for example, the sensitivity at 433.92MHz/FSK/20Kbit/s/ $\pm 19.5\text{kHz}$ /Manchester can be improved from -105.5dBm to -106.7dBm . The sensitivity also depends on the values in the registers of the control logic which examines the incoming data stream. The examination limits must be programmed in control registers 5 and 6. The measurements in [Table 5-3](#) and [Table 5-4 on page 10](#) are based on the values of registers 5 and 6 according to [Table 11-3 on page 55](#).

Figure 5-1. Input Matching to 50Ω

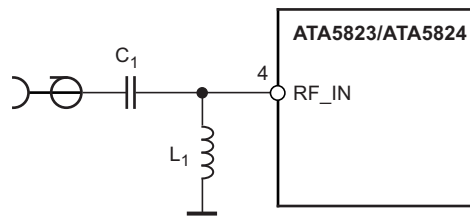

Table 5-2. Input Matching to 50Ω

f_{RF}/MHz	C_1/pF	L_1/nH	Q_{L1}
315	2.4	47	65
433.92	1.8	27	67

Table 5-3. Measured Typical Sensitivity 433.92MHz, FSK, $\pm 19.5\text{kHz}$, Manchester, BER = 10^{-3}

RF Frequency	BR_Range_0 1.0Kbit/s	BR_Range_0 2.4Kbit/s	BR_Range_1 5.0Kbit/s	BR_Range_2 10Kbit/s	BR_Range_3 20Kbit/s
315MHz	-109.5dBm	-110.0dBm	-109.0dBm	-107.5dBm	-106.5dBm
433.92MHz	-108.5dBm	-109.0dBm	-108.0dBm	-106.5dBm	-105.5dBm

Table 5-4. Measured Typical Sensitivity 433.92 MHz, 100% ASK, Manchester, BER = 10^{-3}

RF Frequency	BR_Range_0 1.0Kbit/s	BR_Range_0 2.4Kbit/s	BR_Range_1 5.0Kbit/s	BR_Range_2 10Kbit/s	
315MHz	-117.0dBm	-117.0dBm	-114.5dBm	-112.5dBm	
433.92MHz	-116.0dBm	-116.0dBm	-113.5dBm	-111.5dBm	

5.3 Sensitivity versus Supply Voltage, Temperature and Frequency Offset

To calculate the behavior of a transmission system it is important to know the reduction of the sensitivity due to several influences. The most important are frequency offset due to crystal oscillator (XTO) and crystal frequency (XTAL) errors, temperature and supply voltage dependency of the noise figure and IF filter bandwidth of the receiver. Figure 5-2 shows the typical sensitivity at 433.92MHz/FSK/20Kbit/s/±19.5kHz/Manchester versus the frequency offset between transmitter and receiver at $T_{amb} = -40^{\circ}\text{C}$, $+25^{\circ}\text{C}$ and $+105^{\circ}\text{C}$ and supply voltage $V_S = V_{S1} = V_{S2} = 2.15\text{V}$, 3.0V and 3.6V .

Figure 5-2. Measured Sensitivity 433.92MHz/FSK/20Kbit/s/±19.5kHz/Manchester versus Frequency Offset, Temperature and Supply Voltage

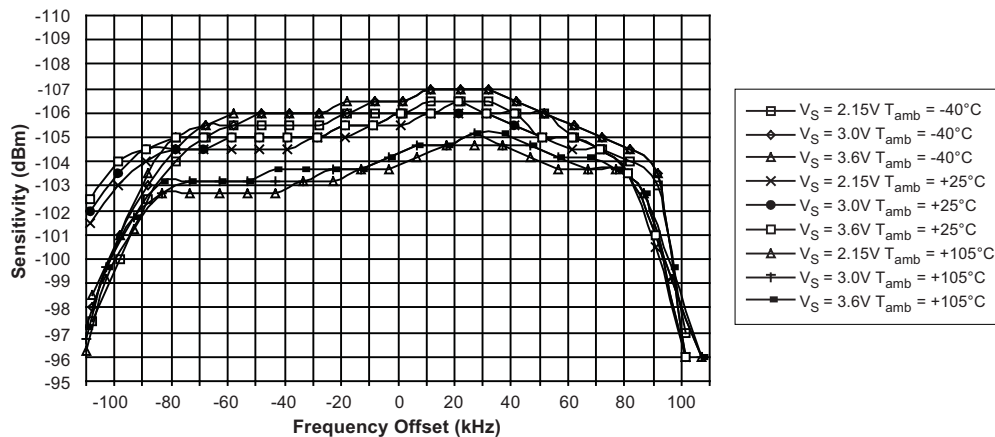

As can be seen in Figure 5-2 on page 11 the supply voltage has almost no influence on the sensitivity. The temperature has an influence of about $+1.5/-0.7\text{dB}$ and a frequency offset of $\pm 85\text{kHz}$ also influences by about $\pm 1\text{dB}$. All these influences, combined with the sensitivity of a typical IC (-105.5dBm), are then within a range of -102.5dBm and -107dBm overtemperature, supply voltage and frequency offset. The integrated IF filter has an additional production tolerance of $\pm 10\text{kHz}$, hence, a frequency offset between the receiver and the transmitter of $\pm 75\text{kHz}$ can be accepted for XTAL and XTO tolerances.

Note: For the demodulator used in the Atmel ATA5823/ATA5824, the tolerable frequency offset does not change with the data frequency, hence, the value of $\pm 75\text{kHz}$ is valid for 1Kbit/s to 20Kbit/s .

This small sensitivity change over supply voltage, frequency offset and temperature is very unusual in such a receiver. It is achieved by an internal, very fast and automatic frequency correction in the FSK demodulator after the IF filter, which leads to a higher system margin. This frequency correction tracks the input frequency very quickly, if however, the input frequency makes a larger step (e.g., if the system changes between different communication partners), the receiver has to be restarted. This can be done by switching back to IDLE mode and then again to RX mode. For that purpose, an automatic mode is also available. This automatic mode switches to IDLE mode and back into RX mode every time a bit error occurs (see section “Digital Control Logic” on page 32).

5.4 Frequency Accuracy of the Crystals in Bi-directional RKE/PEG

The XTO is an amplitude regulated Pierce type oscillator with integrated load capacitors. The initial tolerances (due to the frequency tolerance of the XTAL, the integrated capacitors on XTAL1, XTAL2 and the XTO’s initial transconductance g_m) can be compensated to a value within $\pm 0.5\text{ppm}$ by measuring the CLK output frequency and tuning of f_{RF} by programming the control registers 2 and 3 (see Table 9-7 on page 34 and Table 9-10 on page 35). The XTO then has a remaining influence of less than $\pm 2\text{ppm}$ overtemperature and supply voltage due to the bandgap controlled g_m of the XTO. Thus only 2.5ppm add to the frequency stability of the used crystals overtemperature and aging.

The needed frequency stability of the used crystals **overtemperature and aging** is hence $\pm 75\text{kHz}/433.92\text{MHz} - 2 \times \pm 2.5\text{ppm} = \pm 167.84\text{ppm}$ for 433.92MHz . Thus, the used crystals in receiver and transmitter each need to be better than $\pm 83.9\text{ppm}$ for 433.92MHz .

5.5 Frequency Accuracy of the Crystals in a Combined RKE/PEG and TPM System

In a tire pressure measurement system working at 433.92MHz and using a TPM transmitter Atmel® ATA5757 and a transceiver Atmel ATA5824 as a receiver, the higher frequency tolerances and the tolerance of the frequency deviation of this transmitter has to be considered.

In the TPM transmitter the crystal has an frequency error overtemperature -40°C to $+125^{\circ}\text{C}$, aging and tolerance of $\pm 80\text{ppm}$ ($\pm 34.7\text{kHz}$ at 433.92MHz). The tolerances of the XTO, the capacitors used for FSK-Modulation and the stray capacitors, causing an additional frequency error of $\pm 30\text{ppm}$ ($\pm 13\text{kHz}$ at 433.92MHz). The frequency deviation of such a transmitter varies between $\pm 16\text{kHz}$ and $\pm 24\text{kHz}$, since a higher frequency deviation is equivalent to an frequency error, this has to be considered as an additional $\pm 24\text{kHz} - \pm 19.5\text{kHz} = \pm 4.5\text{kHz}$ frequency tolerance. All tolerances added, these transmitters have a worst case frequency offset of $\pm 52.2\text{kHz}$.

For the transceiver in the car a tolerance of $\pm 75\text{kHz} - \pm 52.2\text{kHz} = \pm 22.8\text{kHz}$ ($\pm 52.5\text{ppm}$) remains. The needed frequency stability of the used crystals **overtemperature and aging** is $\pm 52.5\text{ppm} - \pm 2.5\text{ppm} = \pm 50\text{ppm}$. The aging of such a crystal is $\pm 10\text{ppm}$ leaving reasonable $\pm 40\text{ppm}$ for the temperature dependency of the crystal frequency in the car.

Since the transceiver in the car is able to receive these TPM transmitter signals with high frequency offsets, the component specification in the key can be largely relaxed.

This system calculation is based on worst case tolerances of all the components, this leads in practice to a system with margin.

For a 315MHz TPM system using a TPM transmitter Atmel ATA5756 and a transceiver Atmel ATA5823 as receiver the same calculation must be done, but since the RF frequency is lower, every ppm of crystal tolerances results in less frequency offset and either the system can have higher tolerances or a higher margin there.

5.6 RX Supply Current versus Temperature and Supply Voltage

Table 5-5 shows the typical supply current at 433.92MHz of the transceiver in RX mode versus supply voltage and temperature with $V_S = V_{S1} = V_{S2}$. As can be seen the supply current at $V_S = 2.15\text{V}$ and $T_{\text{amb}} = -40^{\circ}\text{C}$ is less than at $V_S = 3\text{V}/T_{\text{amb}} = 25^{\circ}$ which helps to enlarge the battery lifetime within a key fob application because this is also the operation point where a lithium cell has the worst performance. The typical supply current at 315MHz in RX mode is about the same as for 433.92MHz.

Table 5-5. Measured 433.92MHz Receive Supply Current in FSK mode

$V_S = V_{S1} = V_{S2}$	2.15V	3.0V	3.6V
$T_{\text{amb}} = -40^{\circ}\text{C}$	8.2mA	8.8mA	9.2mA
$T_{\text{amb}} = 25^{\circ}\text{C}$	9.7mA	10.3mA	10.8mA
$T_{\text{amb}} = 105^{\circ}\text{C}$	11.2mA	11.9mA	12.4mA

5.7 Blocking, Selectivity

As can be seen in [Figure 5-3](#), [Figure 5-4](#) and [Figure 5-5 on page 13](#), the receiver can receive signals 3dB higher than the sensitivity level in presence of large blockers of $-44.5\text{dBm}/-36.0\text{dBm}$ with small frequency offsets of $\pm 1/\pm 10\text{MHz}$.

[Figure 5-3](#) and [Figure 5-4 on page 13](#) shows the close-in and narrow-band blocking and [Figure 5-5 on page 13](#) the wide-band blocking characteristic. The measurements were done with a useful signal of $433.92\text{MHz}/\text{FSK}/20\text{Kbit/s}/\pm 19.5\text{kHz}/\text{Manchester}$ with a level of $-105.5\text{dBm} + 3\text{dB} = -102.5\text{dBm}$ which is 3dB above the sensitivity level. The figures show by how much a continuous wave signal can be larger than -102.5dBm until the BER is higher than 10^{-3} . The measurements were done at the 50Ω input according to [Figure 5-1 on page 10](#). At 1MHz, for example, the blocker can be 58dBC higher than -102.5dBm which is $-102.5\text{dBm} + 58\text{dBC} = -44.5\text{dBm}$. These blocking figures, together with the good intermodulation performance, avoid the additional need of a SAW filter in the key fob application.

Figure 5-3. Close In 3dB Blocking Characteristic and Image Response at 433.92MHz

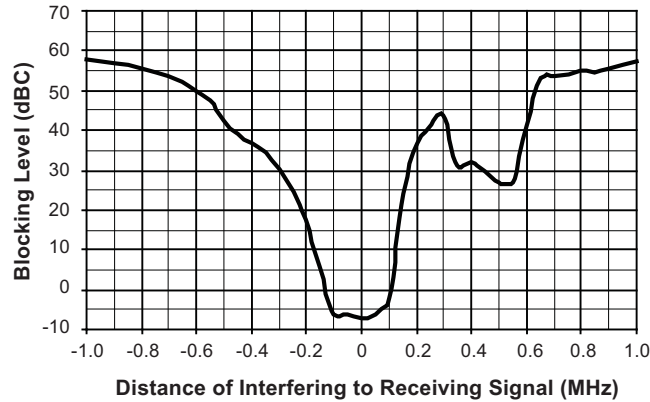

Figure 5-4. Narrow Band 3dB Blocking Characteristic at 433.92MHz

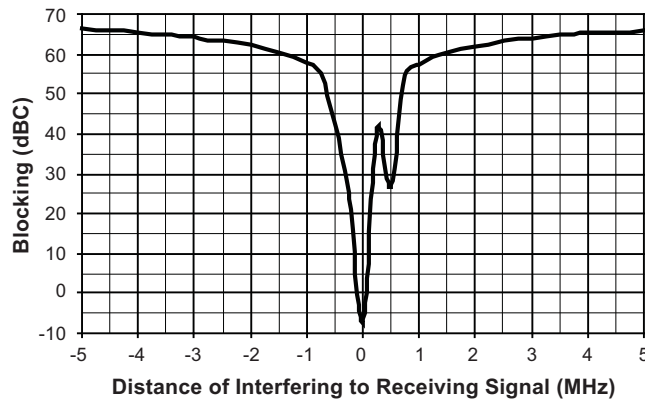

Figure 5-5. Wide Band 3dB Blocking Characteristic at 433.92MHz

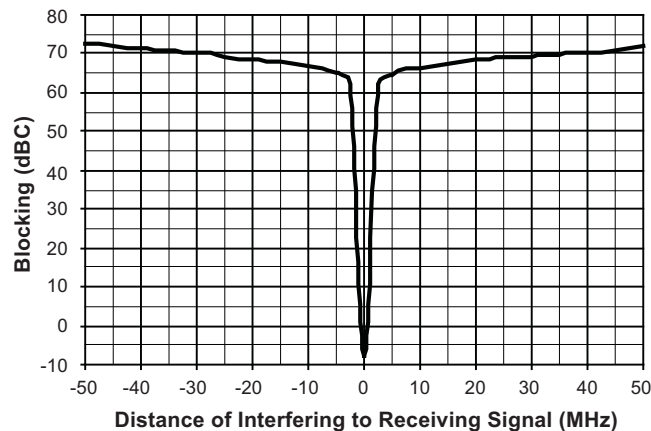

Table 5-6 shows the blocking performance measured relative to -102.5dBm for some frequencies. Note that sometimes the blocking is measured relative to the sensitivity level -105.5dBm (denoted dBS) instead of the carrier -102.5dBm (denoted dBC).

Table 5-6. Blocking 3 dB Above Sensitivity Level with BER $< 10^{-3}$

Frequency Offset	Blocker Level	Blocking
+0.75MHz	-47.5dBm	55.0dBC/58.0dBS
-0.75MHz	-47.5dBm	55.0dBC/58.0dBS
+1.0MHz	-44.5dBm	58.0dBC/61.0dBS
-1.0MHz	-44.5dBm	58.0dBC/61.0dBS
+1.5MHz	-42.0dBm	60.5dBC/63.5dBS
-1.5MHz	-42.0dBm	60.5dBC/63.5dBS
+10MHz	-35.5dBm	67.0dBC/70.0dBS
-10MHz	-35.5dBm	67.0dBC/70.0dBS

The Atmel® ATA5823/ATA5824 can also receive FSK and ASK modulated signals if they are much higher than the I1dBCP. It can typically receive useful signals at $+10\text{dBm}$. This is often referred to as the nonlinear dynamic range which is the maximum to minimum receiving signal which is 115.5dB for $433.92\text{MHz/FSK/20Kbit/s}/\pm 19.5\text{kHz/Manchester}$. This value is useful if two transceivers have to communicate and are very close to each other.

In a keyless entry system there is another blocking characteristic that has to be considered. A keyless entry system has a typical service range of about 30m with a receiver sensitivity of about -106dBm to -109dBm . In some cases, large blockers limit this service range, and it is important to know how large this blockers can be until the system doesn't work anymore and the user has to use its key. With a recommended sensitivity of about -85dBm , the system works just around the car. Figure 5-6 and Figure 5-7 on page 15 show the blocking performance in this important case with a useful signal of -85dBm $433.92\text{MHz/FSK/20Kbit/s}/\pm 19.5\text{kHz/Manchester}$.

As can be seen the system works even with blockers above the compression point. This is due to a wide bandwidth automatic gain control that begins to work if blockers above the compression point are at the antenna input and increasing the current in the LNA/Mixer to get a better compression point needed to handle these large blockers.

Figure 5-6. $\pm 2.5\text{MHz}$ Blocking Characteristic for -85dBm Useful Signal at 433.92MHz

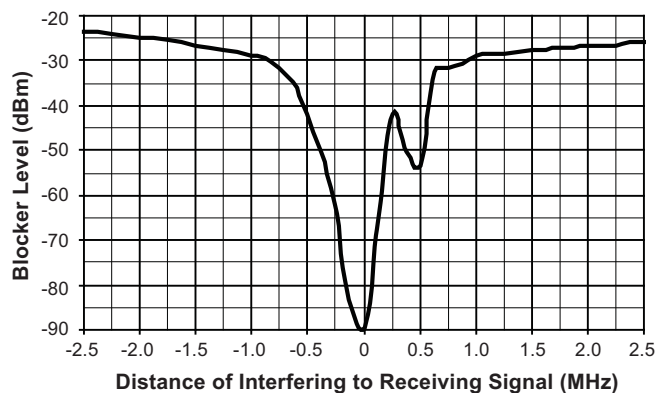
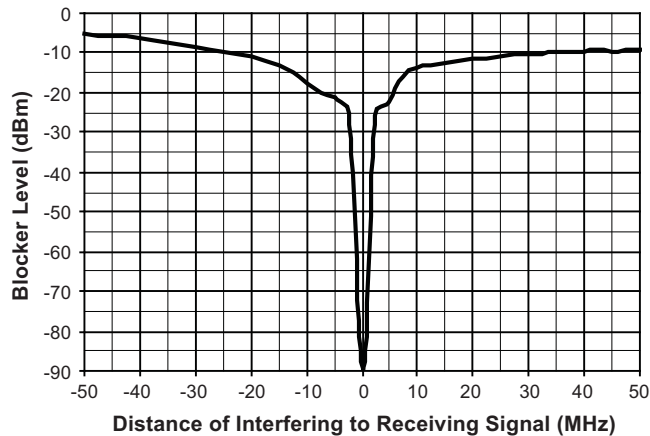

Figure 5-7. ± 50 MHz Blocking Characteristic for -85 dBm Useful Signal at 433.92MHz



This high blocking performance makes it even possible for some applications using quarter wave whip antennas to use a simple LC band-pass filter instead of a SAW filter in the receiver. When designing such a LC filter, take into account that the 3dB blocking at $433.92\text{MHz}/2 = 216.96\text{MHz}$ is 42dBC and at $433.92\text{MHz}/3 = 144.64\text{MHz}$ is 47dBC. And especially that at $3 \times (433.92\text{MHz} + 226\text{kHz}) + 226\text{kHz} = 1302.664\text{MHz}$ the receiver has a second LO harmonic receiving frequency with only 17dBC blocking.

5.8 Inband Disturbance, Data Filter, Quasi-peak Detector, Data Slicer

If a disturbing signal falls into the received band, or a blocker is not a continuous wave, the performance of a receiver strongly depends on the circuits after the IF filter. Hence the demodulator, data filter and data slicer are important in that case.

The data filter of the Atmel[®] ATA5823/ATA5824 implies a quasi-peak detector. This results in a good suppression of above mentioned disturbers and exhibits a good carrier to noise performance. The required ratio of useful signal to disturbing signal, at a BER of 10^{-3} is less than 12dB in ASK mode and less than 3dB (BR_Range_0 ... BR_Range_2) and 6dB (BR_Range_3) in FSK mode. Due to the many different possible waveforms these numbers are measured for signal as well as for disturbers with peak amplitude values. Note that these values are worst case values and are valid for any type of modulation and modulating frequency of the disturbing signal as well as the receiving signal. For many combinations, lower carrier to disturbing signal ratios are needed.

5.9 TEST3 Output

The internal raw output signal of the demodulator Demod_Out is available at pin TEST3. TEST3 is an open drain output and must be connected to a pull-up resistor if it is used (typically $100\text{k}\Omega$), otherwise no signal is present at that pin. This signal is mainly used for debugging purposes during the setup of a new application, since the received data signal can be seen there without any digital processing.

5.10 RSSI Output

The output voltage of the pin RSSI is an analog voltage, proportional to the input power level. Using the RSSI output signal, the signal strength of different transmitters can be distinguished. The usable dynamic range of the RSSI amplifier is 70dB, the input power range P_{RF_IN} is -115dBm to -45dBm and the gain is 8mV/dB . [Figure 5-8 on page 16](#) shows the RSSI characteristic of a typical device at 433.92MHz with $V_{S1} = V_{S2} = 2.15\text{V}$ to 3.6V and $T_{amb} = -40^{\circ}\text{C}$ to $+105^{\circ}\text{C}$ with a matched input according to [Table 5-2 on page 10](#) and [Figure 5-1 on page 10](#). At 315MHz about 1dB less signal level is needed for the same RSSI results.

Figure 5-8. Typical RSSI Characteristic at 433.92MHz versus Temperature and Supply Voltage

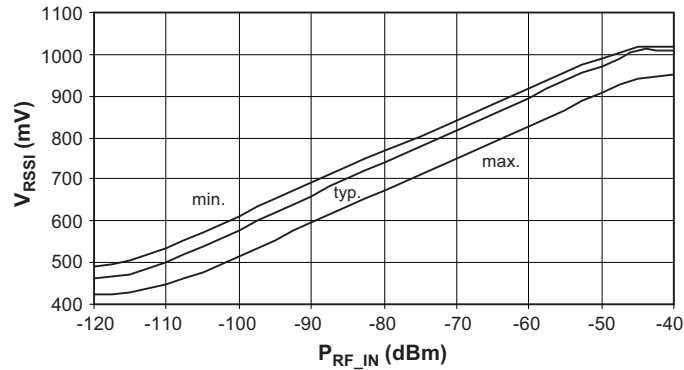

5.11 Frequency Synthesizer and Channel Selection

The synthesizer is a fully integrated fractional-N design with internal loop filters for receive and transmit mode. The XTO frequency f_{XTO} is the reference frequency FREF for the synthesizer. The bits FR0 to FR12 in control registers 2 and 3 (see [Table 9-7 on page 34](#) and [Table 9-10 on page 35](#)) are used to adjust the deviation of f_{XTO} . In half-duplex transmit mode, at 433.92MHz , the carrier has a phase noise of -111dBC/Hz at 1MHz and spurious at FREF of -70dBC with a high PLL loop bandwidth allowing the direct modulation of the carrier with 20Kbit/s Manchester data. Due to the closed loop modulation, any spurious caused by this modulation are effectively filtered out as can be seen in [Figure 5-11 on page 18](#). In RX mode the synthesizer has a phase noise of -120dBC/Hz at 1MHz and spurious of -72dBC .

The initial tolerances of the crystal oscillator due to crystal frequency tolerances, internal capacitor tolerances and the parasitics of the board have to be compensated at manufacturing setup with control registers 2 and 3 as can be seen in [Table 6-1 on page 25](#). The other control words for the synthesizer needed for ASK, FSK and receive/transmit switching are calculated internally. The RF (Radio Frequency) resolution is equal to the XTO frequency divided by 16384 which is 777.1Hz at 315.0MHz and 808.9Hz at 433.92MHz .

The frequency control word FREQ in control registers 2 and 3 can be programmed in the range of 1000 to 6900, hence every frequency within the 433MHz ISM bands can be programmed as receive and as transmit frequency and the position of channels within these ISM bands can be chosen arbitrarily (see [Table 6-1 on page 25](#)).

Care must be taken regarding the harmonics of the CLK output signal as well as to the harmonics produced by a microprocessor clocked with it, since these harmonics can disturb the reception of signals. In a single channel system using $\text{FREQ} = 3803$ to 4053 ensures that harmonics of this signal, do not disturb the receive mode.

5.12 FSK/ASK Transmission

Due to the fast modulation capability of the synthesizer and the high resolution, the carrier can be internally FSK modulated which simplifies the application of the transceiver. The deviation of the transmitted signal is ± 24 digital frequency steps of the synthesizer which is equal to $\pm 18.65\text{kHz}$ for 315MHz and $\pm 19.41\text{kHz}$ for 433.92MHz .

Due to closed loop modulation with PLL filtering, the modulated spectrum is very clean, meeting ETSI and CEPT regulations when using a simple LC filter for the power amplifier harmonics as it is shown in [Figure 4-1](#). In ASK mode the frequency is internally connected to the center of the FSK transmission and the power amplifier is switched on and off to perform the modulation. [Figure 5-9](#) to [Figure 5-11](#) on page 18 show the spectrum of the FSK modulation with pseudo-random data with $20\text{Kbit/s}/\pm 19.41\text{kHz}/\text{Manchester}$ and 5dBm output power.

Figure 5-9. FSK-modulated TX Spectrum (433.92MHz/20Kbit/s/ $\pm 19.41\text{kHz}$ /Manchester Code)

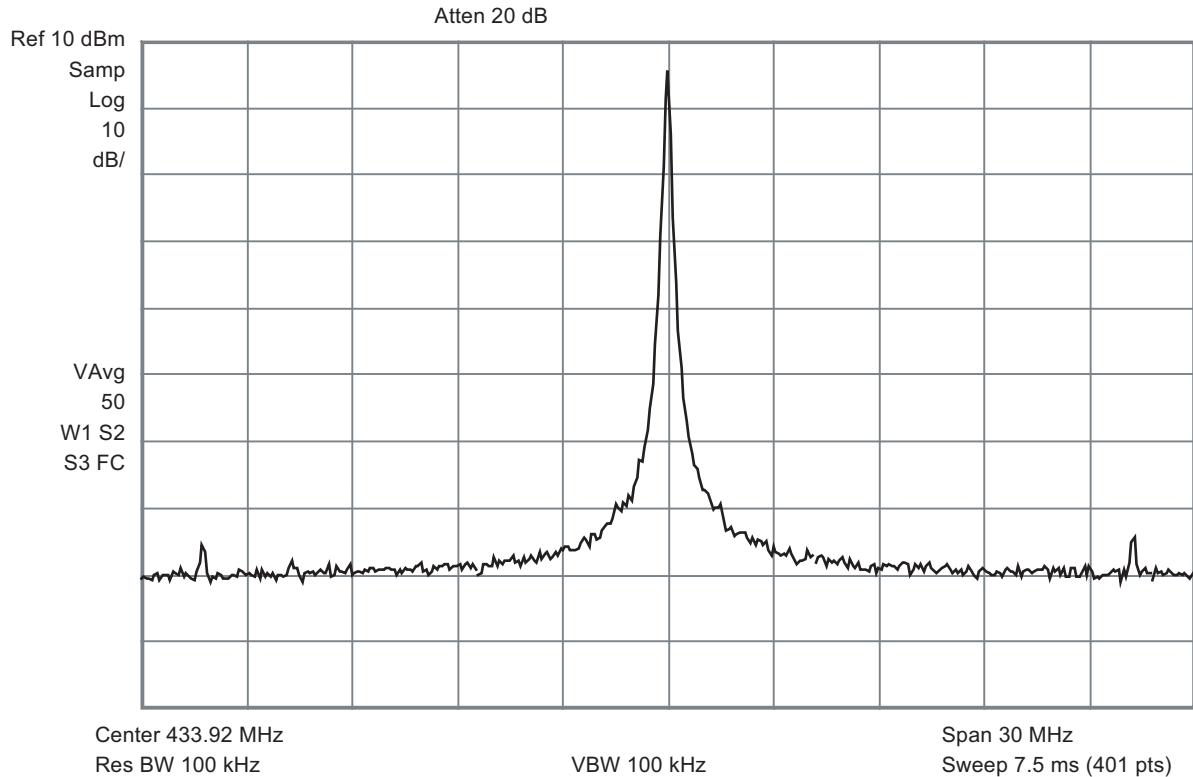

Figure 5-10. Unmodulated TX Spectrum 433.92MHz - 19.41kHz (f_{FSK_L})

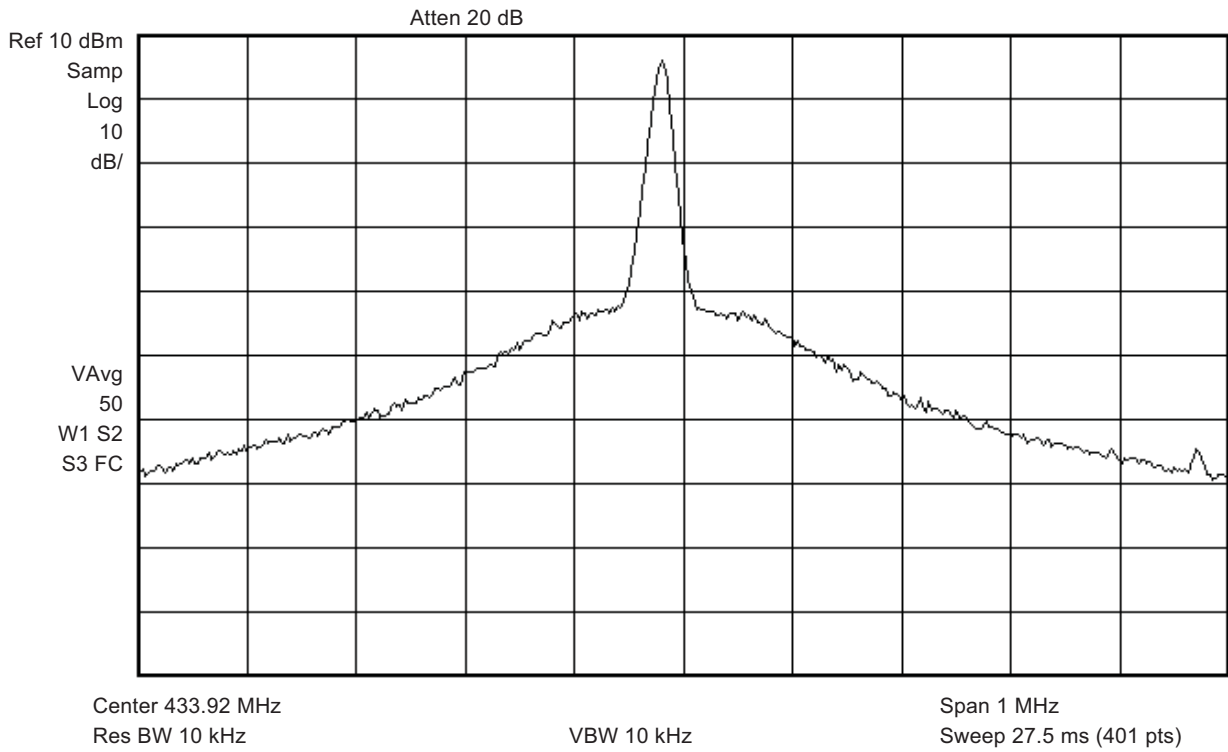
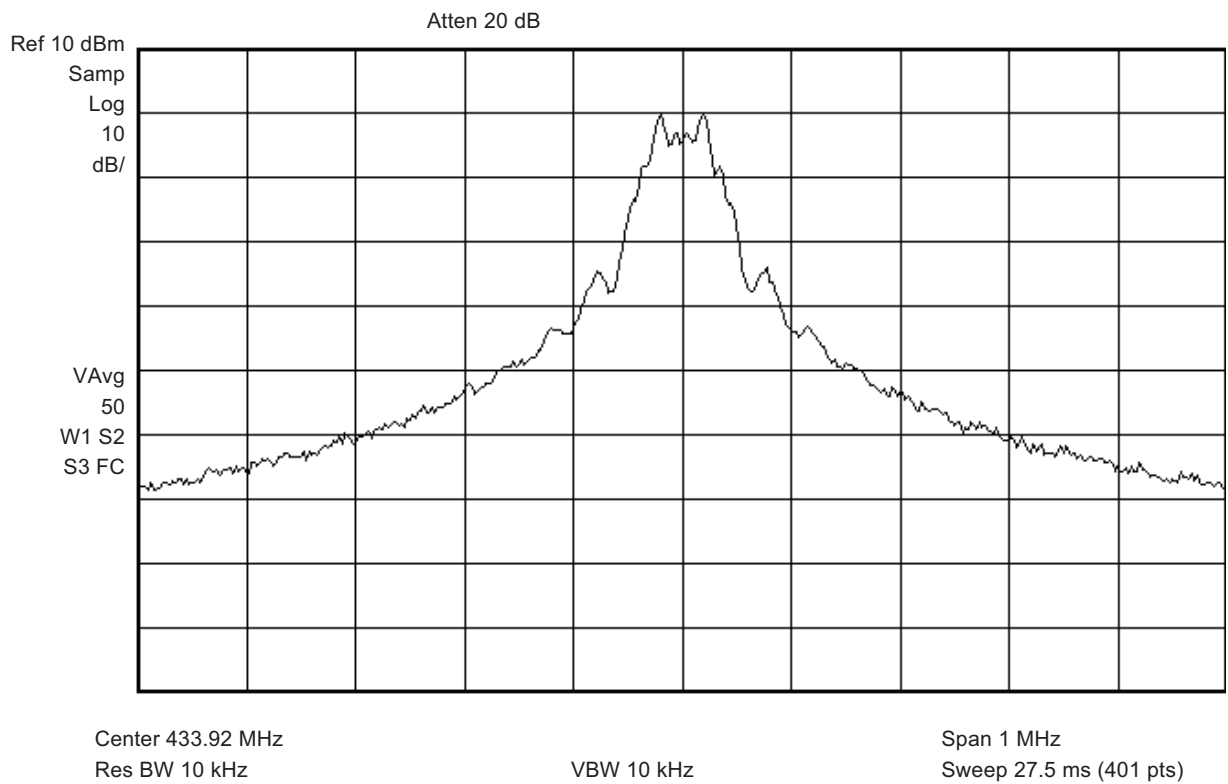

Figure 5-11. FSK-modulated TX Spectrum (433.92MHz/20Kbit/s/±19.41kHz/Manchester Code)



5.13 Output Power Setting and PA Matching at RF_OUT

The Power Amplifier (PA) is a single-ended open collector stage which delivers a current pulse which is nearly independent of supply voltage, temperature and tolerances due to band-gap stabilization. Resistor R_1 (see [Figure 5-12 on page 20](#)) sets a reference current which controls the current in the PA. A higher resistor value results in a lower reference current, a lower output power and a lower current consumption of the PA. The usable range of R_1 is 15k Ω to 56k Ω . The PWR_H pin switches the output power range between about 0dBm to 5dBm (PWR_H = GND) and 5dBm to 10dBm (PWR_H = AVCC) by multiplying this reference current with a factor 1 (PWR_H = GND) and 2.5 (PWR_H = AVCC) which corresponds to about 5dB more output power.

If the PA is switched off in TX mode, the current consumption without output stage and with $V_{S1} = V_{S2} = 3V$, $T_{amb} = 25^\circ C$ is typically 6.95mA for 315MHz and 433.92MHz.

The maximum output power is achieved with optimum load resistances R_{Lopt} according to [Table 5-7 on page 20](#). The compensation of the 1.0pF output capacitance of the RF_OUT pin will be achieved by absorbing it into the matching network, consisting of L_1 , C_1 , C_3 as shown in [Figure 5-12 on page 20](#). There must be also a low resistive DC path to AVCC to deliver the DC current of the power amplifier's last stage. The matching of the PA output was done with the circuit according to [Figure 5-12 on page 20](#) with the values in [Table 5-7](#). Note that value changes of these elements may be necessary to compensate individual board layout parasitics.

Example:

According to [Table 5-7 on page 20](#), with a frequency of 433.92MHz and output power of 11dBm, the overall current consumption is typically 17.8mA. Hence the PA needs 17.8mA - 6.95mA = 10.85mA in this mode which corresponds to an overall power amplifier efficiency of the PA of $(10^{(11dBm/10)} \times 1mW)/(3V \times 10.85mA) \times 100\% = 38.6\%$ in this case.

Using a higher resistor in this example of $R_1 = 1.091 \times 22k\Omega = 24k\Omega$ results in 9.1% less current in the PA of 10.85mA/1.091 = 9.95mA and $10 \times \log(1.091) = 0.38dB$ less output power if using a new load resistance of $300\Omega \times 1.091 = 327\Omega$. The resulting output power is then 11dBm - 0.38dB = 10.6dBm and the overall current consumption is 6.95mA + 9.95mA = 16.9mA.

The values of [Table 5-7 on page 20](#) were measured with standard multi-layer chip inductors with quality factors Q according to [Table 5-7 on page 20](#).

Looking to the 433.92MHz/11dBm case with the quality factor of $Q_{L1} = 43$ the loss in this inductor L_1 is estimated with the parallel equivalent resistance of the inductor $R_{loss} = 2 \times \pi \times f \times L_1 \times Q_{L1}$ and the matching loss with $10 \log(1 + R_{Lopt}/R_{loss})$ which is equal to 0.32dB losses in this inductor. Taking this into account the PA efficiency is then 42% instead of 38.6%.

Be aware that the high power mode (PWR_H = AVCC) can only be used with a supply voltage higher than 2.7V, whereas the low power mode (PWR_H = GND) can be used down to 2.15V as can be seen in the section "[Electrical Characteristics: General](#)" on page 61.

The supply blocking capacitor C_2 (10nF) in [Figure 5-12 on page 20](#) has to be placed close to the matching network because of the RF current flowing through it.

An internal programmable resistor SETPWR is programmable with the control register 8, described in [Table 9-25 on page 39](#). It can be used in conjunction with an external resistor to adjust the output power by connection it. To do that the output power should be adjusted with an external resistor about 50% lower than needed for the target output power and reduced with the programmable resistor during production test until the target power is as close as possible to the target. For example, if using 433.92MHz at 5dBm, a resistor of 12k instead of 24k is used and values of PWSET between 25 and 29 can be used to achieve an output power within 5dBm $\pm 0.5dB$ over production. Note that this resistor is temperature stable but has tolerances of $\pm 20\%$ and introduces, therefore, additional output power tolerances, it is recommended to adjust output power during the production test if using the SETPWR resistor.

Figure 5-12. Power Setting and Output Matching

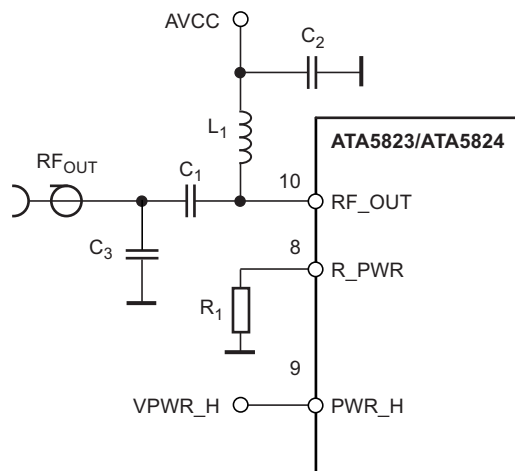

Table 5-7. Measured Output Power and Current Consumption with $V_{S1} = V_{S2} = 3V$, $T_{amb} = 25^{\circ}C$

Frequency (MHz)	TX Current (mA)	Output Power (dBm)	R1 (k Ω)	VPWR_H	R_{Lopt} (Ω)	L_1 (nH)	Q_{L1}	C_1 (pF)	C_3 (pF)
315	8.5	0.4	56	0	2500	82	28	1.5	0
315	10.5	5.7	27	0	920	68	32	2.2	0
315	16.7	10.5	27	AVCC	350	56	35	3.9	0
433.92	8.6	0.1	56	0	2300	56	40	0.75	0
433.92	11.2	6.2	22	0	890	47	38	1.5	0
433.92	17.8	11	22	AVCC	300	33	43	2.7	0

5.14 Output Power and TX Supply Current versus Supply Voltage and Temperature

Table 5-8 shows the measurement of the output power for a typical device with $V_{S1} = V_{S2} = V_S$ in the 433.92MHz and 6.2dBm case versus temperature and supply voltage measured according to Figure 5-12 on page 20 with components according to Table 5-7 on page 20. As opposed to the receiver sensitivity the supply voltage has here the major impact on output power variations because of the large signal behavior of a power amplifier. Thus a 5V system using the internal voltage regulator shows much less variation than a 2.15V to 3.6V battery system because the AVCC supply voltage is $3.25V \pm 0.25V$ for a 5V system.

The reason is that the amplitude at the output RF_OUT with optimum load resistance is $AVCC - 0.4V$ and the power is proportional to $(AVCC - 0.4V)^2$ if the load impedance is not changed. This means that the theoretical output power reduction if reducing the supply voltage from 3.0V to 2.15V is $10 \log ((3V - 0.4V)^2 / (2.15V - 0.4V)^2) = 3.4dB$. Table 5-8 shows that principle behavior in the measurements. This is not the same case for higher voltages, since here, increasing the supply voltage from 3V to 3.6V should theoretical increase the power by 1.8dB, but only 0.9dB in the measurements shows that the amplitude does not increase with the supply voltage because the load impedance is optimized for 3V and the output amplitude stays more constant because of the current source nature of the output.

Table 5-8. Measured Output Power and Supply Current at 433.92MHz, PWR_H = GND

$V_S = V_{S1} = V_{S2}$	2.15V	3.0V	3.6V
$T_{amb} = -40^{\circ}\text{C}$	9.25mA 3.2dBm	10.19mA 5.5dBm	10.78mA 6.2dBm
$T_{amb} = +25^{\circ}\text{C}$	10.2mA 3.4dBm	11.19mA 6.2dBm	11.79mA 7.1dBm
$T_{amb} = +105^{\circ}\text{C}$	10.9mA 3.0dBm	12.02mA 5.4dBm	12.73mA 6.3dBm

Table 5-9 shows the relative changes of the output power of a typical device compared to 3.0V/25°C. As can be seen, a temperature change to -40°C as well as to +105°C reduces the power by less than 1dB due to the band-gap regulated output current. Measurements of all the cases in Table 5-7 on page 20 overtemperature and supply voltage have shown about the same relative behavior as shown in Table 5-9.

Table 5-9. Measurements of Typical Output Power Relative to 3V/25°C

$V_S = V_{S1} = V_{S2}$	2.15V	3.0V	3.6V
$T_{amb} = -40^{\circ}\text{C}$	-3.0dB	-0.7dB	0dB
$T_{amb} = +25^{\circ}\text{C}$	-2.8dB	0dB	+0.9dB
$T_{amb} = +105^{\circ}\text{C}$	-3.2dB	-0.8dB	+0.1dB

5.15 RX/TX Switch

The RX/TX switch decouples the LNA from the PA in TX mode, and directs the received power to the LNA in RX mode. To do this, it has a low impedance to GND in TX mode and a high impedance to GND in RX mode. The pin 38 (RX_TX2) must always be connected to GND in the application. To design a proper RX/TX decoupling a linear simulation tool for radio frequency design together with the measured device impedances of Table 5-1 on page 10, Table 5-7 on page 20, Table 5-10 on page 21 and Table 5-11 on page 22 should be used. The exact element values have to be found on board. Figure 5-13 on page 21 shows an approximate equivalent circuit of the switch. The principal switching operation is described here according to the application of Figure 3-1 on page 7. The application of Figure 4-1 on page 8 works similarly.

Table 5-10. Impedance of the RX/TX Switch RX_TX2 Shorted to GND

Frequency	Z(RX_TX1) TX mode	Z(RX_TX1) RX mode
315MHz	$(4.8 + j3.2)\Omega$	$(11.3 - j214)\Omega$
433.92MHz	$(4.5 + j4.3)\Omega$	$(10.3 - j153)\Omega$

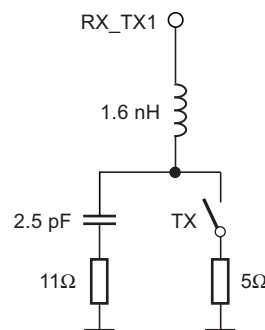
Figure 5-13. Equivalent Circuit of the Switch

5.16 Matching Network in TX Mode

In TX mode the 20mm long and 0.4mm wide transmission line which is much shorter than $\lambda/4$ is approximately switched in parallel to the capacitor C_9 to GND. The antenna connection between C_8 and C_9 has an impedance of about 50Ω looking from the transmission line into the loop antenna with pin RF_OUT, L_2 , C_{10} , C_8 and C_9 connected (using a C_9 without the added 7.6pF capacitor as discussed later). The transmission line can be approximated with a 16nH inductor in series with a 1.5Ω resistor, the closed switch can be approximated according to Table 5-10 with the series connection of 1.6nH and 5Ω in this mode. To have a parallel resonant high impedance circuit with little RF power going into it looking, from the loop antenna into the transmission line a capacitor of about 7.6pF to GND is needed at the beginning of the transmission line (this capacitor is later absorbed into C_9 , which is then higher as needed for 50Ω transformation). To keep the 50Ω impedance in RX mode at the end of this transmission line C_7 has to be also about 7.6pF. This reduces the TX power by about 0.5dB at 433.92MHz compared to the case where the LNA path is completely disconnected.

5.17 Matching Network in RX Mode

In RX mode the RF_OUT pin has a high impedance of about $7k\Omega$ in parallel with 1.0pF at 433.92MHz as can be seen in Table 5-11 on page 22. This together with the losses of the inductor L_2 with 120nH and $Q_{L2} = 25$ gives about $3.7k\Omega$ loss impedance at RF_OUT. Since the optimum load impedance in TX mode for the power amplifier at RF_OUT is 890Ω the loss associated with the inductor L_2 and the RF_OUT pin can be estimated to be $10 \times \log(1 + 890/3700) = 0.95\text{dB}$ compared to the optimum matched loop antenna without L_2 and RF_OUT. The switch represents, in this mode at 433.92MHz, about an inductor of 1.6nH in series with the parallel connection of 2.5pF and $2.0k\Omega$. Since the impedance level at pin RX_TX1 in RX mode is about 50Ω there is only a negligible damping of the received signal by about 0.1dB. When matching the LNA to the loop antenna the transmission line and the 7.6pF part of C_9 has to be taken into account when choosing the values of C_{11} and L_1 so that the impedance seen from the loop antenna into the transmission line with the 7.6pF capacitor connected is 50Ω .

Since the loop antenna in RX mode is loaded by the LNA input impedance the loaded Q of the loop antenna is lowered by about a factor of 2 in RX mode hence the antenna bandwidth is higher than in TX mode.

Table 5-11. Impedance RF_OUT Pin in RX mode

Frequency	Z(RF_OUT)RX	$R_p//C_p$
315MHz	$36\Omega - j 502\Omega$	$7k\Omega//1.0\text{pF}$
433.92MHz	$19\Omega - j 366\Omega$	$7k\Omega//1.0\text{pF}$

Note that if matching to 50Ω , like in Figure 4-1 on page 8, a high Q wire wound inductor with a $Q > 70$ should be used for L_2 to minimize its contribution to RX losses which will otherwise be dominant. The RX and TX losses will be in the range of 1.0dB there.

6. XTO

The XTO is an amplitude regulated Pierce oscillator type with integrated load capacitances ($2 \times 18\text{pF}$ with a tolerance of $\pm 17\%$) hence $C_{L\text{min}} = 7.4\text{pF}$ and $C_{L\text{max}} = 10.6\text{pF}$. The XTO oscillation frequency f_{XTO} is the reference frequency FREF for the fractional-N synthesizer. When designing the system in terms of receiving and transmitting frequency offset the accuracy of the crystal and XTO have to be considered.

The synthesizer can adjust the local oscillator frequency for the initial frequency error in f_{XTO} . This is done at nominal supply voltage and temperature with the control registers 2 and 3 (see [Table 9-7 on page 34](#) and [Table 9-10 on page 35](#)). The remaining local oscillator tolerance at nominal supply voltage and temperature is then $< \pm 0.5\text{ppm}$. The XTO's gm has very low influence of less than $\pm 2\text{ppm}$ on the frequency at nominal supply voltage and temperature.

In a single channel system less than $\pm 150\text{ppm}$ should be corrected to avoid that harmonics of the CLK output disturb the receive mode. If the CLK is not used, or carefully layouted on the application PCB (as needed for multi channel systems), more than $\pm 150\text{ppm}$ can be compensated.

The additional XTO pulling is only $\pm 2\text{ppm}$, overtemperature and supply voltage. The XTAL versus temperature and its aging is then the main source of frequency error in the local oscillator.

The XTO frequency depends on XTAL properties and the load capacitances $C_{L1,2}$ at pin XTAL1 and XTAL2. The pulling of f_{XTO} from the nominal f_{XTAL} is calculated using the following formula

$$P = \frac{C_m}{2} \times \frac{C_{LN} - C_L}{(C_0 + C_{LN}) \times (C_0 + C_L)} \times 10^6 \text{ ppm.}$$

C_m is the crystal's motional, C_0 the shunt and C_{LN} the nominal load capacitance of the XTAL found in its datasheet. C_L is the total actual load capacitance of the crystal in the circuit and consists of C_{L1} and C_{L2} in series connection.

Figure 6-1. XTAL with Load Capacitances

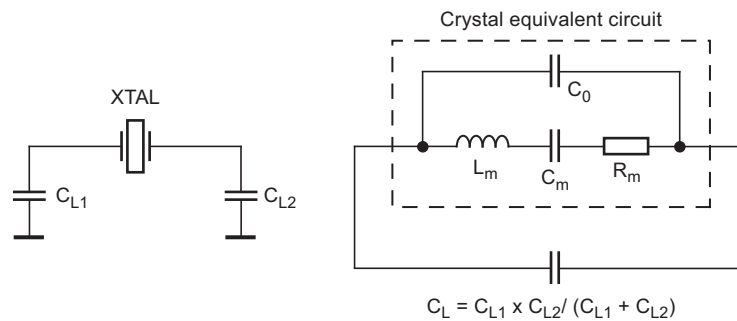

With $C_m \leq 14\text{fF}$, $C_0 \geq 1.5\text{pF}$, $C_{LN} = 9\text{pF}$ and $C_L = 7.4\text{pF}$ to 10.6pF the pulling amounts to $P \leq \pm 100\text{ppm}$ and with $C_m \leq 7\text{fF}$, $C_0 \geq 1.5\text{pF}$, $C_{LN} = 9\text{pF}$ and $C_L = 7.4\text{pF}$ to 10.6pF the pulling is $P \leq \pm 50\text{ppm}$.

Since typical crystals have less than $\pm 50\text{ppm}$ tolerance at 25°C , the compensation is not critical and can, in both cases, be done with the $\pm 150\text{ppm}$.

C_0 of the XTAL has to be lower than $C_{L\text{min}}/2 = 3.7\text{pF}$ for a Pierce oscillator type in order to not enter the steep region of pulling versus load capacitance where there is a risk of an unstable oscillation.

To ensure proper start-up behavior the small signal gain, and thus the negative resistance provided by this XTO at start is very large. For example oscillation starts up, even in worst case, with a crystal series resistance of $1.5\text{k}\Omega$ at $C_0 \leq 2.2\text{pF}$ with this XTO. The negative resistance is approximately given by

$$\text{Re}\{Z_{\text{XTOcore}}\} = \text{Re}\left\{\frac{Z_1 \times Z_3 + Z_2 \times Z_3 + Z_1 \times Z_2 \times Z_3 \times g_m}{Z_1 + Z_2 + Z_3 + Z_1 \times Z_2 \times g_m}\right\}$$

with Z_1, Z_2 as complex impedances at pin XTAL1 and XTAL2 hence

$$Z_1 = -j/(2 \times \pi \times f_{\text{XTO}} \times C_{L1}) + 5\Omega \text{ and } Z_2 = -j/(2 \times \pi \times f_{\text{XTO}} \times C_{L2}) + 5\Omega.$$

Z_3 consists of crystals C_0 in parallel with an internal $110\text{k}\Omega$ resistor hence

$$Z_3 = -j/(2 \times \pi \times f_{\text{XTO}} \times C_0) / 110\text{k}\Omega, g_m \text{ is the internal transconductance between XTAL1 and XTAL2 with typically } 19\text{ms at } 25^\circ\text{C}.$$

With $f_{XTO} = 13.5\text{MHz}$, $g_m = 19\text{ms}$, $C_L = 9\text{pF}$, $C_0 = 2.2\text{pF}$ this results in a negative resistance of about $2\text{k}\Omega$. The worst case for technological, supply voltage and temperature variations is then for $C_0 \leq 2.2\text{pF}$ always higher than $1.5\text{k}\Omega$.

Due to the large gain at start, the XTO is able to meet a very low start-up time. The oscillation start-up time can be estimated with the time constant τ .

$$\tau = \frac{2}{4 \times \pi^2 \times f_m^2 \times C_m \times (\text{Re}(Z_{XTO\text{core}}) + R_m)}$$

After 10τ to 20τ , an amplitude detector detects the oscillation amplitude and sets XTO_OK to High if the amplitude is large enough. This activates the CLK output if CLK_ON and CLK_EN in control register 3 are High (see [Table 9-12 on page 35](#)). Note that the necessary conditions of the DVCC voltage also have to be fulfilled (see [Figure 6-2 on page 24](#) and [Figure 7-1 on page 27](#)).

To save current in IDLE and Sleep mode, the load capacitors partially are switched off in this modes with S_1 and S_2 seen in [Figure 6-2 on page 24](#).

It is recommended to use a crystal with $C_m = 3.0\text{fF}$ to 7.0fF , $C_{LN} = 9\text{pF}$, $R_m < 120\Omega$ and $C_0 = 1.0\text{pF}$ to 2.2pF .

Lower values of C_m can be used, this increases slightly the start-up time. Lower values of C_0 or higher values of C_m (up to 15fF) can also be used, this has only little influence to pulling.

Figure 6-2. XTO Block Diagram

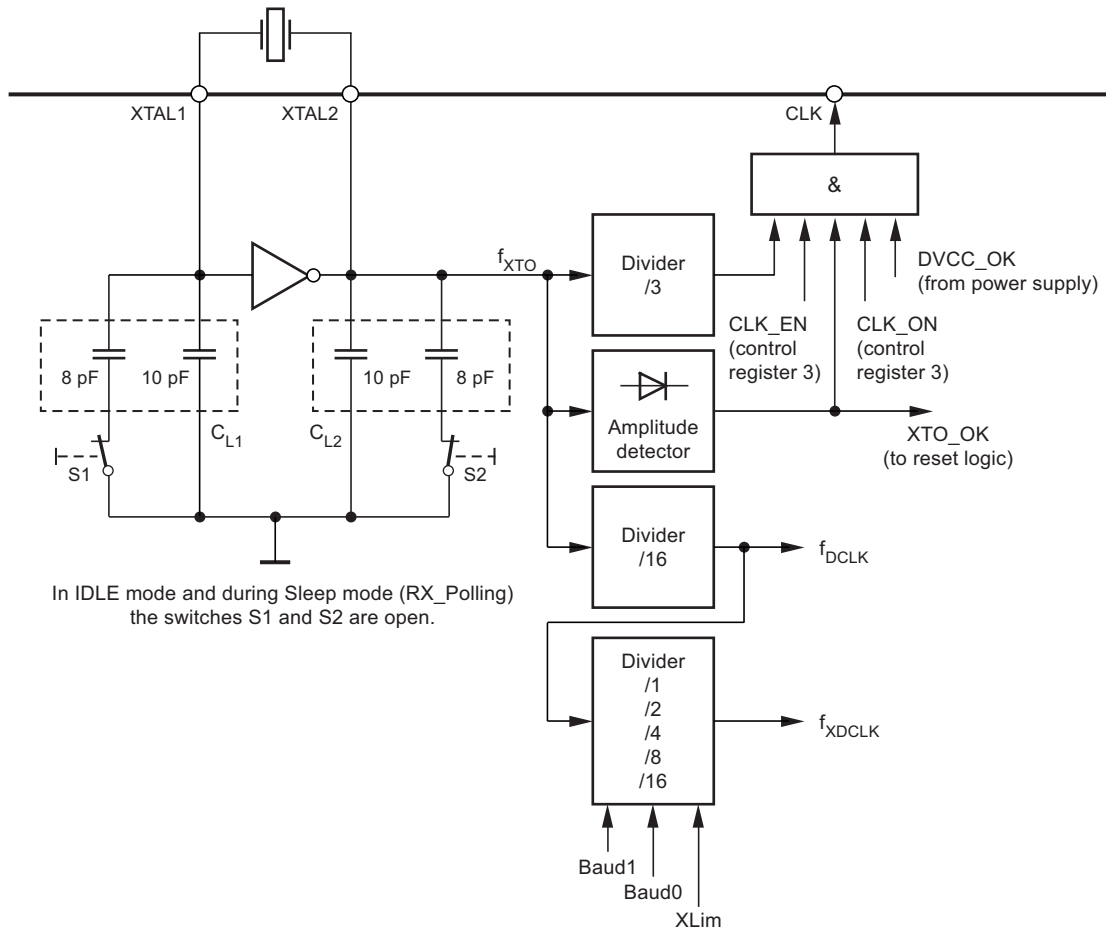

To find the right values used in the control registers 2 and 3 (see [Table 9-7 on page 34](#) and [Table 9-10 on page 35](#)) the relationship between f_{XTO} and the f_{RF} is shown in [Table 6-1](#). To determine the right content, the frequency at pin CLK, as well as the output frequency at RF_OUT in ASK mode can be measured, than the FREQ value can be calculated according to [Table 6-1](#) so that f_{RF} is exactly the desired radio frequency.

Table 6-1. Calculation of f_{RF}

Frequency (MHz)	Pin 6 433_N868	CREG1 Bit(4) FS	f_{XTO} (MHz)	$f_{RF} = f_{TX_ASK} = f_{RX}$	$f_{TX_FSK_L} = f_{TX_FSK_L(FD)}$	$f_{TX_FSK_H}$	$f_{TX_FSK_H(FD)}$	Frequency Resolution
315.0	AVCC	1	12.73193	$f_{XTO} \times \left(24,5 + \frac{FREQ + 24,5}{16384} \right)$	$f_{RF} - 18.65\text{kHz}$	$f_{RF} + 18.65\text{ kHz}$	$f_{RF} + 208.23\text{kHz}$	777.1Hz
433.92	AVCC	0	13.25311	$f_{XTO} \times \left(32,5 + \frac{FREQ + 24,5}{16384} \right)$	$f_{RF} - 19.41\text{kHz}$	$f_{RF} + 19.41\text{kHz}$	$f_{RF} + 203.74\text{kHz}$	808.9Hz

The variable FREQ depends on the bit PLL_MODE in control register 1 and the parameter FREQ2 and FREQ3, which are defined by the bits FR0 to FR12 in control register 2 and 3 and is calculated as follows:

$$FREQ = FREQ2 + FREQ3$$

Care must be taken with the harmonics of the CLK output signal f_{CLK} , as well as to the harmonics produced by an microprocessor clocked with it, since these harmonics can disturb the reception of signals if they get to the RF input. In a single channel system the use of FREQ = 3803 to 4053 ensures that harmonics of this signal do not disturb the receive mode. In a multichannel system the CLK signal can either be not used or carefully layouted on the application PCB. The supply voltage of the microcontroller must also be carefully blocked in a multichannel system.

6.1 Pin CLK

Pin CLK is an output to clock a connected microcontroller. The clock frequency f_{CLK} is calculated as follows:

$$f_{CLK} = \frac{f_{XTO}}{3}$$

The signal at CLK output has a nominal 50% duty cycle.

If the bit CLK_EN in control register 3 is set to 0, the clock is disabled permanently.

If the bit CLK_EN is set to 1 and bit CLK_ON (control register 3) is set to 0, the clock is disabled as well. If bit CLK_ON is set to 1 and thus the clock is enabled if the Bit-check is ok (RX, RX Polling, FD mode (Slave)), an event on pin N_PWR_ON occurs or the bit Power_On in the status register is 1.

Figure 6-3. Clock Timing

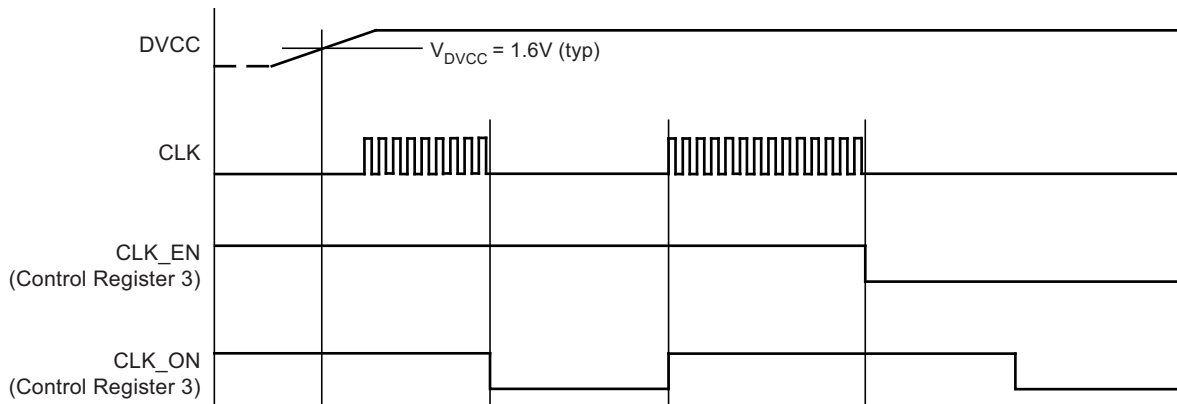

6.2 Basic Clock Cycle of the Digital Circuitry

The complete timing of the digital circuitry is derived from one clock. According to [Figure 6-2 on page 24](#), this clock cycle T_{DCLK} is derived from the crystal oscillator (XTO) in combination with a divider.

$$f_{DCLK} = \frac{f_{XTO}}{16}$$

T_{DCLK} controls the following application relevant parameters:

- Timing of the polling circuit including bit-check
- TX bit rate

The clock cycle of the Bit-check and the TX bit rate depends on the selected bit-rate range (BR_Range) which is defined in control register 6 (see [Table 9-19 on page 37](#)) and X_{Lim} which is defined in control register 4 (see [Table 9-16 on page 36](#)). This clock cycle T_{XDCLK} is defined by the following formulas for further reference:

BR_Range 0:	$T_{XDCLK} = 8 \times T_{DCLK} \times X_{Lim}$
BR_Range 1:	$T_{XDCLK} = 4 \times T_{DCLK} \times X_{Lim}$
BR_Range 2:	$T_{XDCLK} = 2 \times T_{DCLK} \times X_{Lim}$
BR_Range 3:	$T_{XDCLK} = 1 \times T_{DCLK} \times X_{Lim}$

7. Power Supply

Figure 7-1. Power Supply

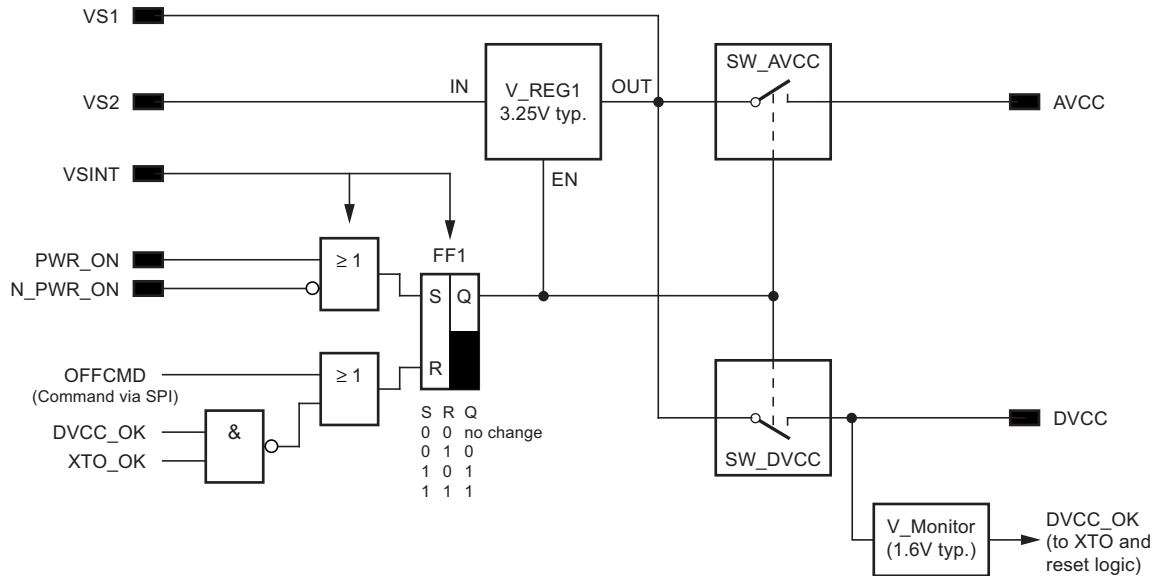

The supply voltage range of the Atmel® ATA5823/ATA5824 is 2.15V to 3.6V or 4.4V to 5.25V.

Pin VS1 is the supply voltage input for the range 2.15V to 3.6V and is used in battery applications using a single lithium 3V cell. Pin VS2 is the voltage input for the range 4.4V to 5.25V (car applications), in this case the voltage regulator V_REG regulates VS1 to typically 3.25V. If the voltage regulator is active, a blocking capacitor of 2.2μF has to be connected to VS1.

Pin VSINT is the voltage input for the Microcontroller_Interface and must be connected to the power supply of the microcontroller. The voltage range of V_{VSINT} is 2.25V to 5.25V (see Figure 7-5 and Figure 7-6 on page 30).

AVCC is the internal operation voltage of the RF transceiver and is fed via the switch SW_AVCC by VS1. AVCC must be blocked on pin AVCC with a 68nF capacitor (see Figure 3-1 on page 7 and Figure 4-1 on page 8).

DVCC is the internal operation voltage of the digital control logic and is fed via the switch SW_DVCC by VS1. DVCC must be blocked on pin DVCC with 68nF (see Figure 3-1 on page 7 and Figure 4-1 on page 8).

Pin PWR_ON is an input to switch on the transceiver (active high).

Pin N_PWR_ON is an input for a push button and can also be used to switch on the transceiver (active low).

For current consumption reasons it is recommended to set N_PWR_ON to GND only temporarily. Otherwise an additional current flows because of a 50kΩ pull-up resistor.

A voltage monitor generates the signal DVCC_OK if DVCC ≥ 1.6V typically.

Figure 7-2. Flow Chart Operation Modes

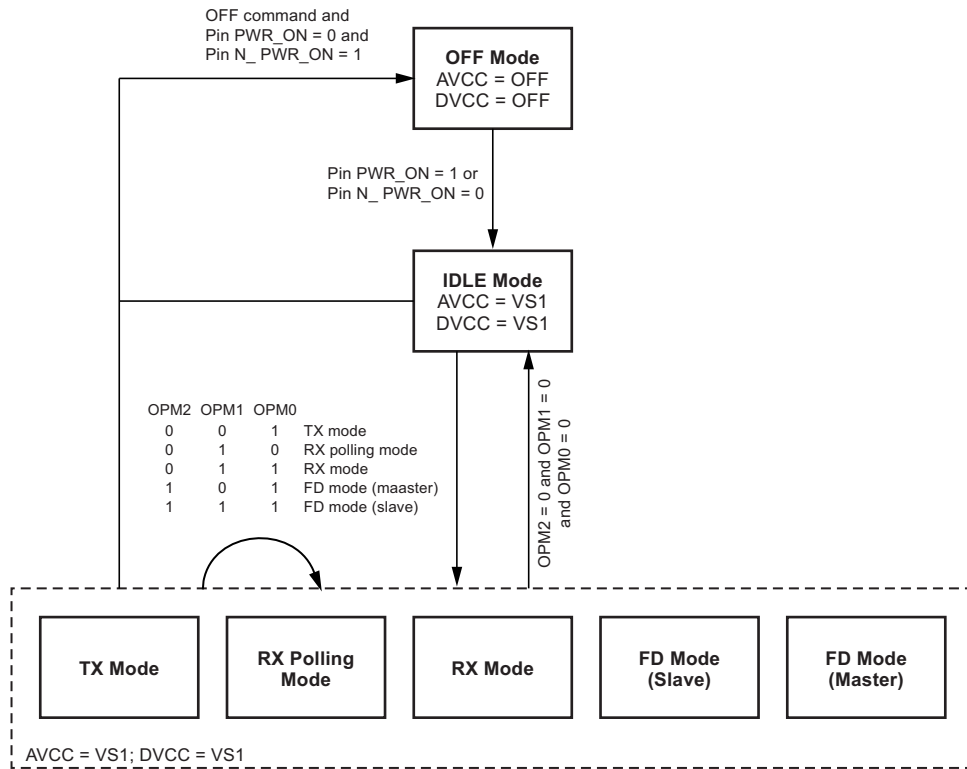

7.1 OFF Mode

After connecting the power supply (battery) to pin VS1 and/or VS2 and VSINT, the transceiver is in OFF mode. In OFF mode AVCC and DVCC are disabled, resulting in very low power consumption (I_{S_OFF} is typically $\leq 10\text{nA}$ in the key fob application [Figure 3-1 on page 7](#) and $\leq 0.5\mu\text{A}$ in the car application [Figure 4-1 on page 8](#)). In OFF mode the transceiver is not programmable via the 4-wire serial interface.

7.2 IDLE Mode

In IDLE mode AVCC and DVCC are connected to the battery voltage (VS1).

From OFF mode the transceiver changes to IDLE mode if pin PWR_ON is set to 1 or pin N_PWR_ON is set to 0. This state transition is indicated by an interrupt at pin IRQ and the status bits Power_On = 1 or N_Power_On = 1.

In IDLE mode the RF transceiver is disabled and the power consumption $I_{IDLE_VS1,2}$ is about 270 μA (CLK output OFF VS1 = VS2 = 3V). The exact value of this current is strongly dependent on the application and the exact operation mode, therefore check the section “Electrical Characteristics” for the appropriate application case.

Via the 4-wire serial interface a connected microcontroller can program the required parameter and enable the TX, RX polling, RX or FD mode. The transceiver can be set back to OFF mode by an OFF command via the 4-wire serial interface (the input level of pin PWR_ON must be 0 and pin N_PWR_ON = 1 before writing the OFF command)

Table 7-1. Control Register 1

OPM2	OPM1	OPM0	Function
0	0	0	IDLE mode

7.3 Reset Timing and Reset Logic

If the transceiver is switched on (OFF mode to IDLE mode) DVCC and AVCC are ramping up as illustrated in Figure 7-3. The internal signal DVCC_RESET resets the digital control logic and sets the control register to default values. Bit DVCC_RST in the status register is set to 1.

After V_{DVCC} exceeds 1.6V (typically) and the start-up time of the XTO is elapsed, the output clock at pin CLK is available. DVCC_RST in the status register is set to 0 if V_{DVCC} exceeds 1.6V, the start-up time of the XTO is elapsed and the status register is read via the 4-wire serial interface.

If V_{DVCC} drops below 1.6V (typically) and pin N_PWR_ON = 1 and pin PWR_ON = 0 the transceiver switches to OFF mode.

Figure 7-3. Reset Timing

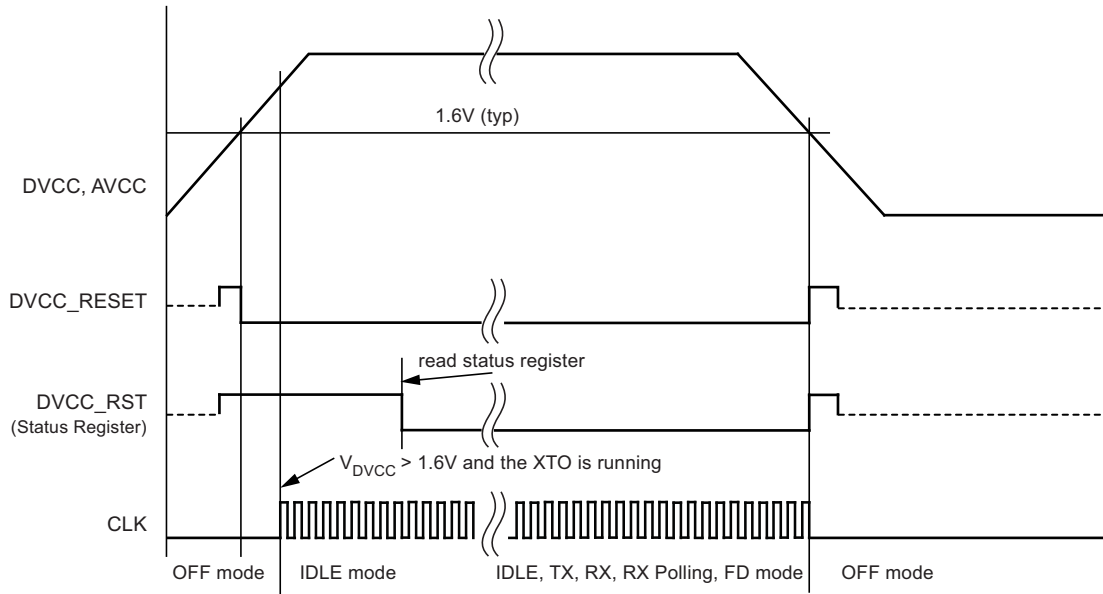
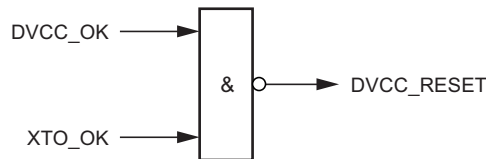

Figure 7-4. Reset Logic



7.4 Battery Application

The supply voltage range is 2.15V to 3.6V.

Figure 7-5. Battery Application

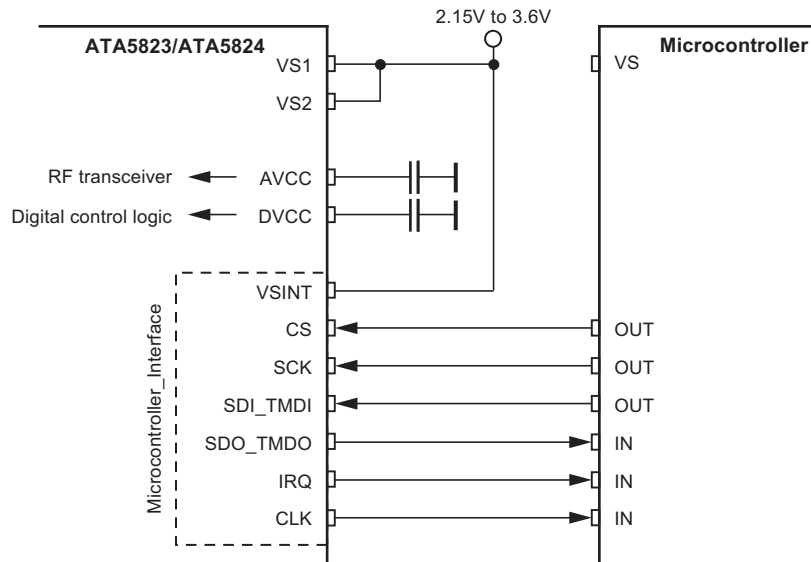

7.5 Car Application

The supply voltage range is 4.4V to 5.25V.

Figure 7-6. Car Application

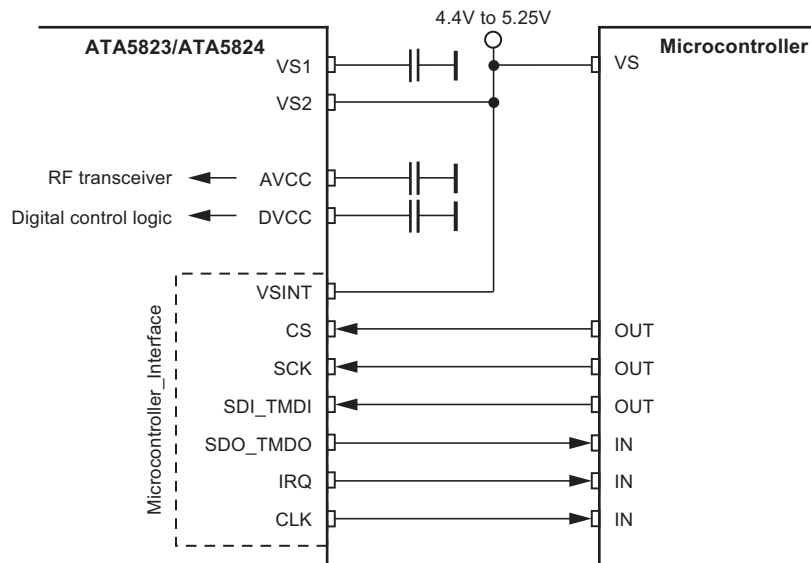

8. Microcontroller Interface

The microcontroller interface is a level converter which converts all internal digital signals which are referred to the DVCC voltage, into the voltage used by the microcontroller. Therefore, the pin VSINT can be connected to the supply voltage of the microcontroller in the case the microcontroller has another supply voltage than the Atmel® ATA5823/ATA5824.

9. Digital Control Logic

9.1 Register Structure

The configuration of the transceiver is stored in RAM cells. The RAM contains a 16×8 -bit TX/RX data buffer and a 8×8 -bit Control register and is write and readable via a 4-wire serial interface (CS, SCK, SDI_TMDI, SDO_TMDO).

The 1×8 -bit status register is not part of the RAM and is readable via the 4-wire serial interface.

The RAM and the status information is stored as long as the transceiver is in any active mode (DVCC = VS1) and gets lost if the transceiver is in the OFF mode (DVCC = OFF).

After the transceiver is turned on via pin PWR_ON = High or pin N_PWR_ON = Low the control registers are in the default state.

Figure 9-1. Register Structure

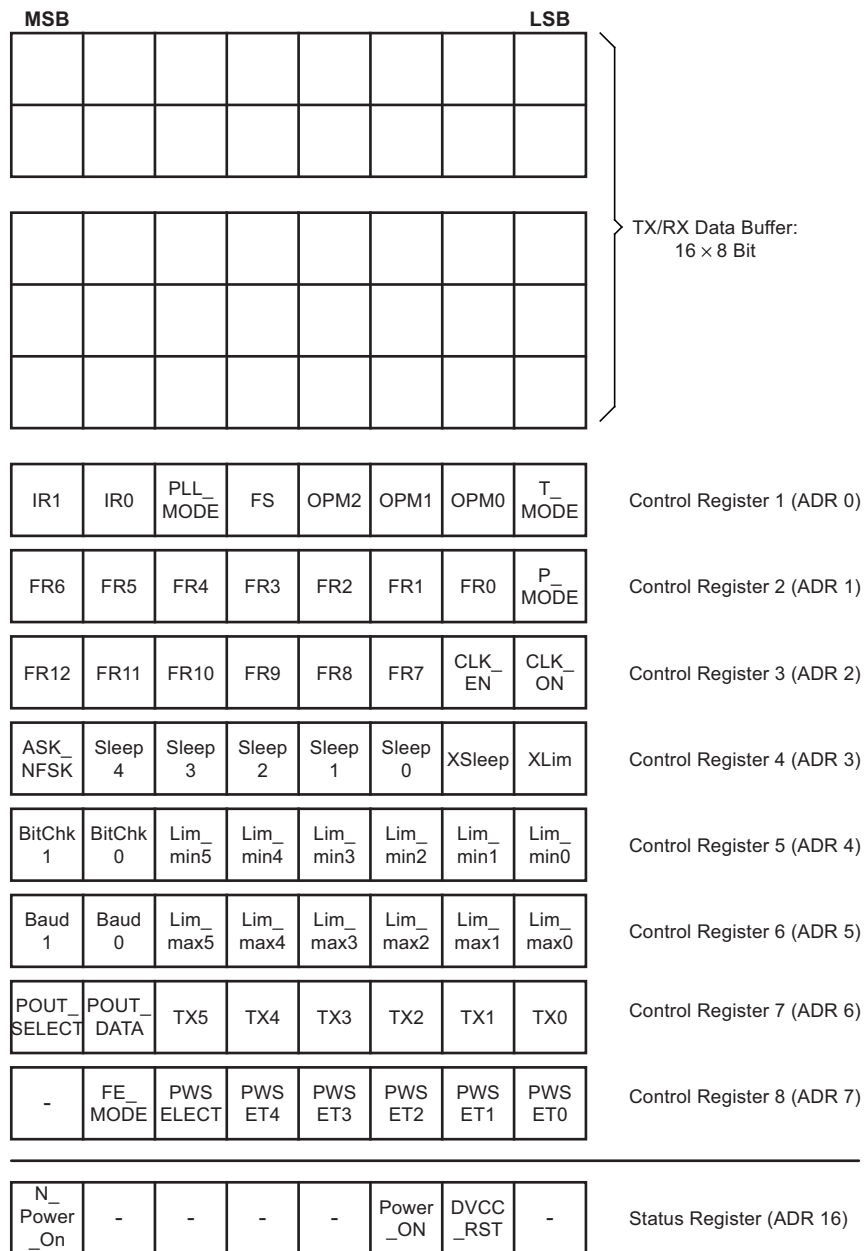

- = Don't care

9.2 TX/RX Data Buffer

The TX/RX data buffer is used to handle the data transfer during RX and TX operations.

9.3 Control Register

To use the transceiver in different applications the transceiver can be configured by a microcontroller connected via the 4-wire serial interface.

9.3.1 Control Register 1 (ADR 0)

Table 9-1. Control Register 1 (Function of Bit 7 and Bit 6 in RX Mode)

IR1	IR0	Function (RX Mode)
0	0	Pin IRQ is set to 1 if 1 received byte is in the TX/RX data buffer or a receiving error occurred
0	1	Pin IRQ is set to 1 if 2 received bytes are in the TX/RX data buffer or a receiving error occurred
1	0	Pin IRQ is set to 1 if 4 received bytes are in the TX/RX data buffer or a receiving error occurred (default)
1	1	Pin IRQ is set to 1 if 12 received bytes are in the TX/RX data buffer or a receiving error occurred

Table 9-2. Control Register 1 (Function of Bit 7 and Bit 6 in TX Mode)

IR1	IR0	Function (TX Mode)
0	0	Pin IRQ is set to 1 if 1 byte still is in the TX/RX data buffer or the TX data buffer is empty
0	1	Pin IRQ is set to 1 if 2 bytes still are in the TX/RX data buffer or the TX data buffer is empty
1	0	Pin IRQ is set to 1 if 4 bytes still are in the TX/RX data buffer or the TX data buffer is empty (default)
1	1	Pin IRQ is set to 1 if 12 bytes still are in the TX/RX data buffer or the TX data buffer is empty

Note: The Bits IR0 and IR1 have no function in FD mode

Table 9-3. Control Register 1 (Function of Bit 5)

PLL_MODE	Function
0	Adjustable range of FREQ: 3072 to 4095 (default), see Table 9-10 on page 35
1	Adjustable range of FREQ: 0 to 8191, see Table 9-11 on page 35

Table 9-4. Control Register 1 (Function of Bit 4)

FS	Function (RX Mode, TX Mode, FD Mode)
0	Selected frequency 433MHz (default)
1	Selected frequency 315MHz

Table 9-5. Control Register 1 (Function of Bit 3, Bit 2 and Bit 1)

OPM2	OPM1	OPM0	Function
0	0	0	IDLE mode (default)
0	0	1	TX mode
0	1	0	RX polling mode
0	1	1	RX mode
1	0	0	-
1	0	1	-
1	1	0	-
1	1	1	-

Table 9-6. Control Register 1 (Function of Bit 0)

T_MODE	Function
0	TX and RX function via TX/RX data buffer (default)
1	Transparent mode, TX/RX data buffer disabled, TX modulation data stream via pin SDI_TMDI, RX modulation data stream via pin SDO_TMDO

9.3.2 Control Register 2 (ADR 1)

Table 9-7. Control Register 2 (Function of Bit 7, Bit 6, Bit 5, Bit 4, Bit 3, Bit 2 and Bit 1)

FR6 2 ⁶	FR5 2 ⁵	FR4 2 ⁴	FR3 2 ³	FR2 2 ²	FR1 2 ¹	FR0 2 ⁰	Function
0	0	0	0	0	0	0	FREQ2 = 0
0	0	0	0	0	0	1	FREQ2 = 1
.	
1	0	1	0	1	0	0	FREQ2 = 84 (default)
.	
1	1	1	1	1	1	1	FREQ2 = 127

Note: Tuning of f_{RF} LSB's (total 13 bits), frequency trimming, resolution of f_{RF} is $f_{XTO}/16384$ which is approximately 800Hz (see section "XTO", [Table 6-1 on page 25](#))

Table 9-8. Control Register 2 (Function of Bit 0 in RX mode)

P_MODE	Function (RX mode)
0	Pin IRQ is set to 1 if the Bit-check is successful (default)
1	No effect on pin IRQ if the Bit-check is successful

Table 9-9. Control Register 2 (Function of Bit 0 in TX mode)

P_MODE	Function (TX mode)
0	Manchester modulator on (default)
1	Manchester modulator off (NRZ mode)

Note: Bit P_MODE has no function in FD mode

9.3.3 Control Register 3 (ADR 2)

Table 9-10. Control Register 3 (Function of Bit 7, Bit 6, Bit 5, Bit 4, Bit 3 and Bit 2 if Bit PLL_MODE = 0 (in Control Register 1))

FR12 2 ¹²	FR11 2 ¹¹	FR10 2 ¹⁰	FR9 2 ⁹	FR8 2 ⁸	FR7 2 ⁷	Function
X	X	X	0	0	0	FREQ3 = 3072
X	X	X	0	0	1	FREQ3 = 3200
X	X	X	0	1	0	FREQ3 = 3328
X	X	X	0	1	1	FREQ3 = 3456
X	X	X	1	0	0	FREQ3 = 3584
X	X	X	1	0	1	FREQ3 = 3712
X	X	X	1	1	0	FREQ3 = 3840(default)
X	X	X	1	1	1	FREQ3 = 3968

Note: Tuning of f_{RF} MSB's

Table 9-11. Control Register 3 (Function of Bit 7, Bit 6, Bit 5, Bit 4, Bit 3 and Bit 2 if Bit PLL_MODE = 1 (in Control Register 1))

FR12 2 ¹²	FR11 2 ¹¹	FR10 2 ¹⁰	FR9 2 ⁹	FR8 2 ⁸	FR7 2 ⁷	Function
0	0	0	0	0	0	FREQ3 = 0
0	0	0	0	0	1	FREQ3 = 128
0	0	0	0	1	0	FREQ3 = 256
.
0	1	1	1	1	0	FREQ3 = 3840 (default)
.
1	1	1	1	1	0	FREQ3 = 7936
1	1	1	1	1	1	FREQ3 = 8064

Note: Tuning of f_{RF} MSB's

Table 9-12. Control Register 3 (Function of Bit 1 and Bit 0)

CLK_EN	CLK_ON	Function (RX Mode, TX Mode, FD Mode)
0	X	Clock output off (pin CLK)
1	0	Clock output off (pin CLK). Clock switched on by an event: <ul style="list-style-type: none"> • Bit-check ok or • event on pin N_PWR_ON or • bit Power_On in the status register is 1
1	1	Clock output on (default)

Note: Bit CLK_ON is set to 1 if the Bit-check is ok (RX_Polling, RX mode), an event at pin N_PWR_ON occurs or the bit Power_On in the status register is 1.

9.3.4 Control Register 4 (ADR 3)

Table 9-13. Control Register 4 (Function of Bit 7)

ASK_NFSK	Function (TX Mode, RX Mode)
0	FSK mode (default)
1	ASK mode

Note: Bit ASK_NFSK has no function in FD mode

Table 9-14. Control Register 4 (Function of Bit 6, Bit 5, Bit 4, Bit 3 and Bit 2)

Sleep4 2 ⁴	Sleep3 2 ³	Sleep2 2 ²	Sleep1 2 ¹	Sleep0 2 ⁰	Function (RX Mode) Sleep ($T_{Sleep} = Sleep \times 1024 \times T_{DCLK} \times X_{Sleep}$)
0	0	0	0	0	0
0	0	0	0	1	1
.	
1	1	0	0	0	24 ($T_{Sleep} = 24 \times 1024 \times T_{DCLK} \times X_{Sleep}$) (default)
.	
1	1	1	1	1	31

Note: Bits Sleep0 ... Sleep4 have no function in TX mode and FD mode

Table 9-15. Control Register 4 (Function of Bit 1)

XSleep	Function
0	$X_{Sleep} = 1$; extended T_{Sleep} off (default)
1	$X_{Sleep} = 8$; extended T_{Sleep} on

Note: Bit X_{Sleep} has no function in TX mode and FD mode

Table 9-16. Control Register 4 (Function of Bit 0)

XLim	Function
0	$X_{Lim} = 1$; extended T_{Lim_min} , T_{Lim_max} off (default)
1	$X_{Lim} = 2$; extended T_{Lim_min} , T_{Lim_max} on

Note: Bit X_{Lim} has no function in TX mode and FD mode

9.3.5 Control Register 5 (ADR 4)

Table 9-17. Control Register 5 (Function of Bit 7 and Bit 6)

BitChk1	BitChk0	Function
0	0	$N_{\text{Bit-check}} = 0$ (0 bits checked during bit-check)
0	1	$N_{\text{Bit-check}} = 3$ (3 bits checked during bit-check) (default)
1	0	$N_{\text{Bit-check}} = 6$ (6 bits checked during bit-check)
1	1	$N_{\text{Bit-check}} = 9$ (9 bits checked during bit-check)

Note: Bits BitChk0 and BitChk1 have no function in TX mode and FD mode Master

Table 9-18. Control Register 5 (Function of Bit 5, Bit 4, Bit 3, Bit 2, Bit 1 and Bit 0)

Lim_min5 2^5	Lim_min4 2^4	Lim_min3 2^3	Lim_min2 2^2	Lim_min1 2^1	Lim_min0 2^0	Function (RX Mode, FD Mode Slave) Lim_min (Lim_min < 10 are not Applicable) ($T_{\text{Lim_min}} = \text{Lim_min} \times T_{\text{XDCLK}}$)
0	0	1	0	1	0	10
0	0	1	0	1	1	11 ($T_{\text{Lim_min}} = 11 \times T_{\text{XDCLK}}$) (default)
.	
1	1	1	1	1	1	63

Bits Lim_min0 to Lim_min5 have no function in TX mode and FD mode Master.

9.3.6 Control Register 6 (ADR 5)

Table 9-19. Control Register 6 (Function of Bit 7 and Bit 6)

Baud1	Baud0	Function (RX Mode, TX Mode, FD Mode)
0	0	Bit-rate range 0 (B0) 1.0 Kbit/s to 2.5 Kbit/s; $T_{\text{XDCLK}} = 8 \times T_{\text{DCLK}} \times X_{\text{Lim}}$
0	1	Bit-rate range 1 (B1) 2.0 Kbit/s to 5.0 Kbit/s; $T_{\text{XDCLK}} = 4 \times T_{\text{DCLK}} \times X_{\text{Lim}}$ Bit-rate in FD mode = $1 / (168 \times T_{\text{DCLK}})$
1	0	Bit-rate range 2 (B2) 4.0 Kbit/s to 10.0 Kbit/s; $T_{\text{XDCLK}} = 2 \times T_{\text{DCLK}} \times X_{\text{Lim}}$ (default)
1	1	Bit-rate range 3 (B3) 8.0 Kbit/s to 20.0 Kbit/s; $T_{\text{XDCLK}} = 1 \times T_{\text{DCLK}} \times X_{\text{Lim}}$ Note that the receiver is not working with >10 Kbit/s in ASK mode

Table 9-20. Control Register 6 (Function of Bit 5, Bit 4, Bit 3, Bit 2, Bit 1 and Bit 0)

Lim_max5 2 ⁵	Lim_max4 2 ⁴	Lim_max3 2 ³	Lim_max2 2 ²	Lim_max1 2 ¹	Lim_max0 2 ⁰	Function (RX Mode, FD Mode Slave) Lim_max (Lim_max < 12 are not Applicable) (T _{Lim_max} = (Lim_max - 1) × T _{XDCLK})
0	0	1	1	0	0	12
0	0	1	1	0	1	13
.	
1	0	0	0	0	0	32 (T _{Lim_max} = (32 - 1) × T _{XDCLK}) (default)
.	
1	1	1	1	1	1	63

Note: Bits Lim_max0 to Lim_max5 have no function in TX mode and FD mode Master

9.3.7 Control Register 7 (ADR 6)

Table 9-21. Control Register 7 (Function of Bit 7 and Bit 6)

POUT_SELECT	POUT_DATA	Function (RX Mode, TX Mode, FD Mode)
0	0	Output level on pin POUT = 0 (default)
0	1	Output level on pin POUT = 1
1	X	Output level on pin POUT = N_RX_ACTIVE ⁽¹⁾

Note: 1. IDLE, TX, FD mode: N_RX_ACTIVE = 1
RX mode: N_RX_ACTIVE = 0

Table 9-22. Control Register 7 (Function of Bit 5, Bit 4, Bit 3, Bit 2, Bit 1 and Bit 0)

TX5 2 ⁵	TX4 2 ⁴	TX3 2 ³	TX2 2 ²	TX1 2 ¹	TX0 2 ⁰	Function (TX Mode) TX (TX < 10 are not Applicable) (TX_Bitrate = 1/(TX + 1) × T _{XDCLK} × 2)
0	0	1	0	1	0	10
0	0	1	0	1	1	11
.	
0	1	0	1	0	0	20 (TX_Bitrate = 1/(20 + 1) × T _{XDCLK} × 2) (default)
.	
1	1	1	1	1	1	63

Note: Bits TX0 to TX5 have no function in RX mode and FD mode

9.3.8 Control Register 8 (ADR 7)

Table 9-23. Control Register 8 (Function of Bit 6)

FE_mode	Function
0	For future use
1	Bit for internal use, must always set to 1 (default)

Table 9-24. Control Register 8 (Function of Bit 5)

PWSELECT	Function (TX Mode, FD Mode)
0	$R_{PWSET} = 140\Omega$ typically in TX-mode and as defined by the bits PWSET0 to PWSET4 in FD mode (default)
1	R_{PWSET} as defined by the bits PWSET0 to PWSET4

Table 9-25. Control Register 8 (Function of Bit 4, Bit 3, Bit 2, Bit 1, Bit 0)

PWSET4 2^4	PWSET3 2^3	PWSET2 2^2	PWSET1 2^1	PWSET0 2^0	Function (TX Mode, FD Mode) (SETPWR: Programmable internal resistor to reduce the output power in FD and TX mode) PWSET $SETPWR = 800\Omega + (31 - PWSET) \times 3k\Omega$ (typically)
0	0	0	0	0	0
0	0	0	0	1	1
.	
1	0	0	0	0	16 (default) $SETPWR = 800\Omega + (31 - 16) \times 3k\Omega$ (typically)
.	
1	1	1	1	0	30
1	1	1	1	1	31

Normally the SETPWR resistor at pin 19 is used in full-duplex mode to decrease the output power until the level at RF_IN is low enough for reception of signals (PWSELECT = 0). With PWSELECT = 1 this resistor can also be used in normal half-duplex TX operation to adjust the output power for production tolerances.

9.3.9 Status Register (ADR 16)

The status register indicates the current status of the transceiver and is readable via the 4-wire serial interface. Setting Power_On or an event on N_Power_On is indicated by an IRQ.

Reading the status register resets the bits Power_On, DVCC_RST and the IRQ.

Table 9-26. Status Register

Status Bit	Function
N_Power_On	Status of pin N_PWR_On Pin N_PWR_ON = 0 → N_Power_On = 1 Pin N_PWR_ON = 1 → N_Power_On = 0 (Figure 9-3 on page 41)
Power_On	Indicates that the transceiver was woken up by pin PWR_ON (rising edge on pin PWR_ON). During Power_On = 1, the bit CLK_ON in control register 3 is set to 1 (Figure 9-4 on page 42).
DVCC_RST	DVCC_RST is set to 1 if the supply voltage of the RAM (V_{DVCC}) was too low and the information in the RAM may be lost. DVCC_RST = 0 → supply voltage of the RAM ok DVCC_RST = 1 → supply voltage of the RAM was too low (typically $V_{DVCC} < 1.6V$) If the transceiver changes from OFF mode to IDLE mode, DVCC_RST will be set to 1. Reading the Status register resets DVCC_RST to 0.

9.4 Pin N_PWR_ON

To switch the transceiver from OFF to IDLE mode, pin N_PWR_ON must be set to 0 (maximum $0.2 \times V_{VS2}$) for at least $T_{N_PWR_ON_IRQ}$ (see [Figure 9-2](#)). The transceiver recognizes the negative edge and switches on DVCC and AVCC.

If V_{DVCC} exceeds 1.6V (typically) and the XTO is settled, the digital control logic is active and sets the status bit N_Power_On to 1, an interrupt is issued ($T_{N_PWR_ON_IRQ}$) and the output clock on pin CLK is available.

If the level on pin N_PWR_ON was set to 1 before the interrupt is issued, the transceiver stays in OFF mode.

Note: It is not possible to set the transceiver to OFF-mode by setting pin N_PWR_ON to 1. If pin N_PWR_ON is not used, it should be left open because of the internal pull-up resistor

Figure 9-2. Timing Pin N_PWR_ON, Status Bit N_Power_On

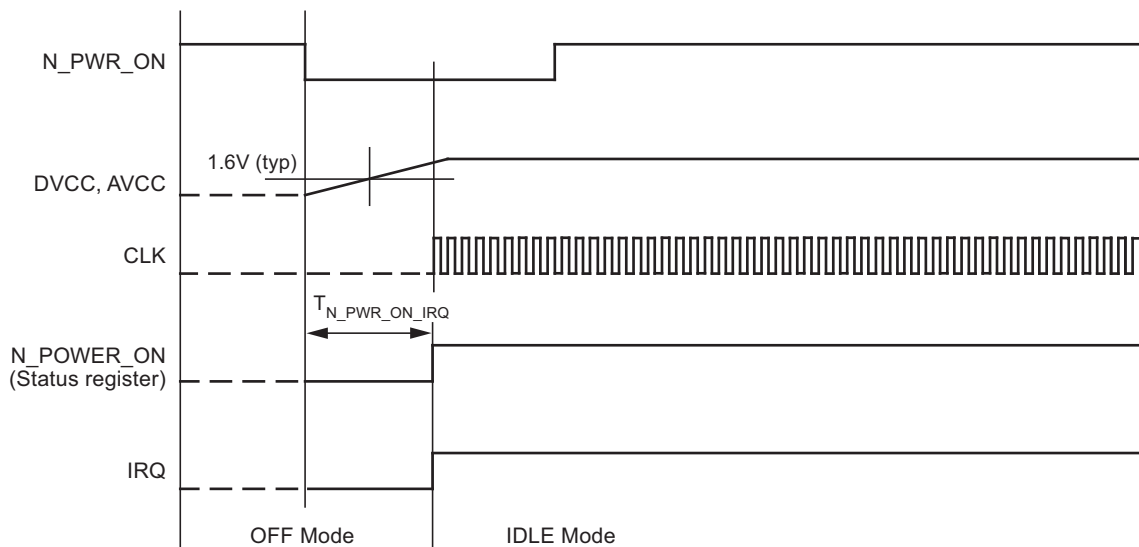

If the transceiver is in any of the active modes (IDLE, TX, RX, RX_Polling, FD), an integrated debounce logic is active. If there is an event on pin N_PWR_ON, a debounce counter is set to 0 ($T = 0$) and started. The status is updated, an interrupt is issued and the debounce counter is stopped after reaching the counter value $T = 8195 \times T_{DCLK}$.

An event on N_PWR_ON before reaching $T = 8195 \times T_{DCLK}$ stops the debounce counter.

While the debounce counter is running, the bit CLK_ON in control register 3 is set to 1.

The interrupt is deleted after reading the status register or executes the command Delete_IRQ.

If pin N_PWR_ON is not used, it can be left open because of an internal pull-up resistor (typically 50k Ω).

Figure 9-3. Timing Flow Pin N_PWR_ON, Status Bit N_Power_On

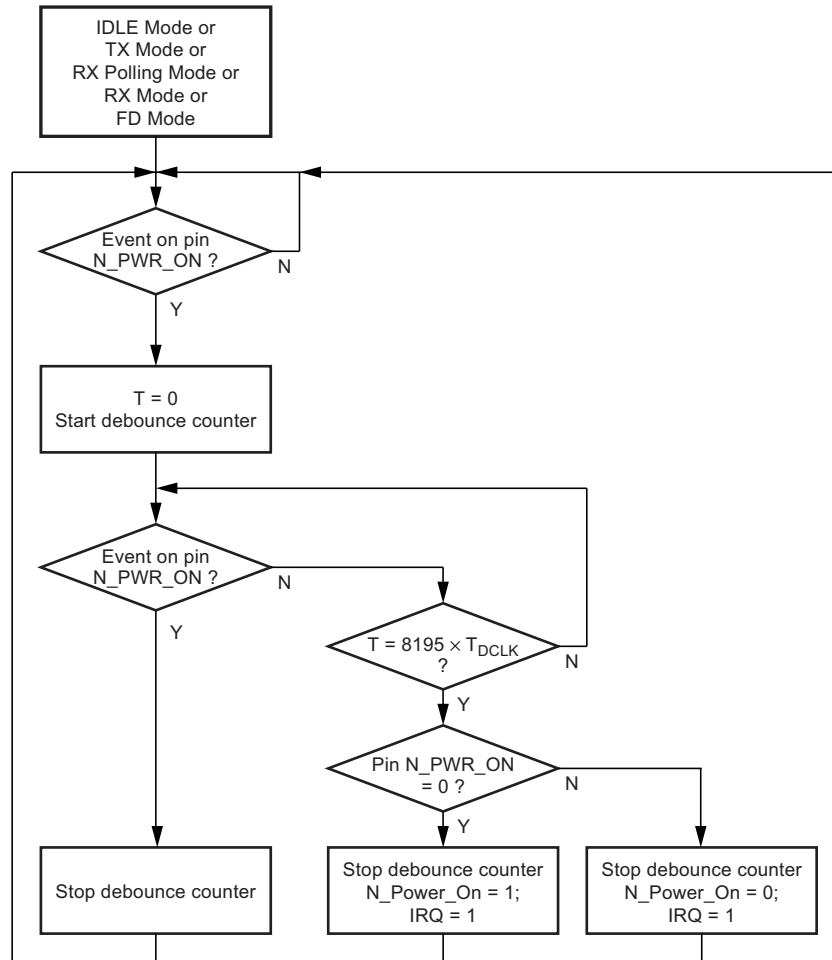

9.5 Pin PWR_ON

To switch the transceiver from OFF to IDLE mode, pin PWR_ON must set to 1 (minimum $0.8 \times V_{VSINT}$) for at least T_{PWR_ON} (see [Figure 9-4 on page 42](#)). The transceiver recognizes the positive edge and switches on DVCC and AVCC.

If V_{DVCC} exceeds 1.6V (typically) and the XTO is settled, the digital control logic is active and sets the status bit Power_On to 1, an interrupt is issued ($T_{PWR_ON_IRQ_1}$) and the output clock on pin CLK is available.

If the level on pin PWR_ON was set to 0 before the interrupt is issued, the transceiver stays in OFF mode.

If the transceiver is in any of the active modes (IDLE, RX, RX_Polling, TX, FD), a positive edge on pin PWR_ON sets Power_On to 1 (after $T_{PWR_ON_IRQ_2}$). The state transition Power_On 0 \rightarrow 1 generates an interrupt. If Power_On is still 1 during the positive edge on pin PWR_ON, no interrupt is issued. Power_On and the interrupt is deleted after reading the status register.

During Power_On = 1, the bit CLK_EN in control register 3 is set to 1.

Note: It is not possible to set the transceiver to OFF mode by setting pin PWR_ON to 0. If pin PWR_ON is not used, it must be connected to GND.

Figure 9-4. Timing Pin PWR_ON, Status Bit Power_On

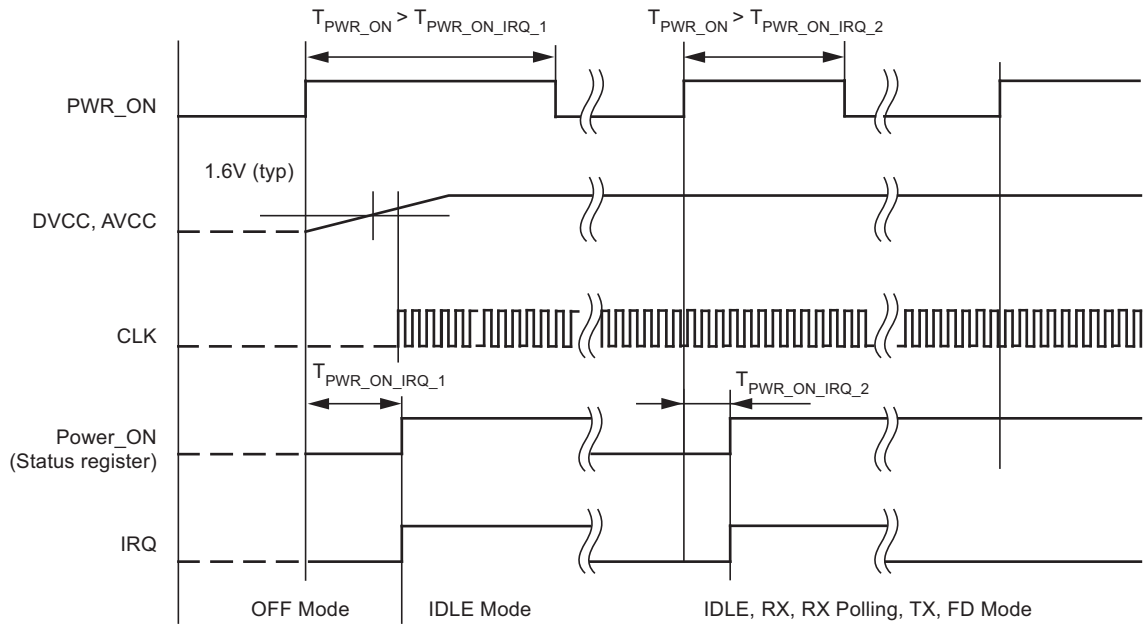

9.6 DVCC_RST

The status bit DVCC_RST is set to 1 if the voltage on pin DVCC V_{DVCC} drops under 1.6V (typically).

DVCC_RST is set to 0 if V_{DVCC} exceeds 1.6V (typically) and the status register is read via the 4-wire serial interface (see [Figure 7-3 on page 29](#)).

Figure 9-5. Timing Flow Status Bit DVCC_RST

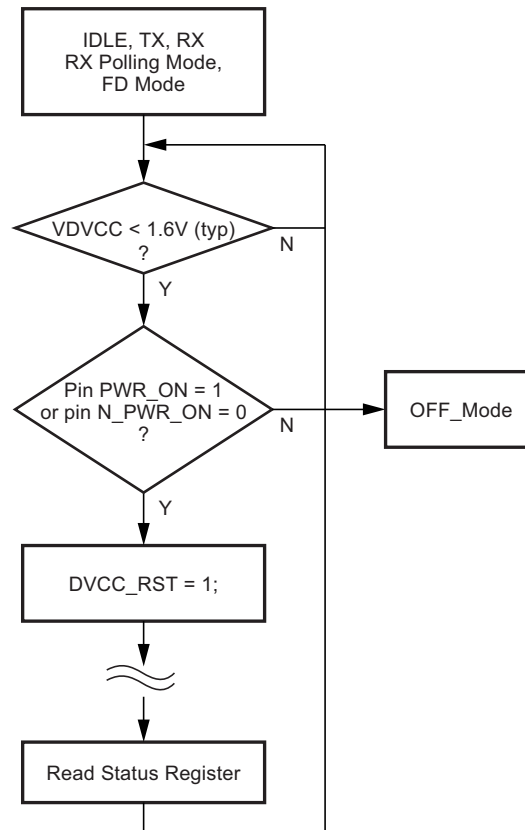

10. Transceiver Configuration

The configuration of the transceiver takes place via a 4-wire serial interface (CS, SCK, SDI_TMDI, SDO_TMDO) and is organized in 8-bit units. The configuration is initiated with a 8-bit command. While shifting the command into pin SDI_TMDI, the number of bytes in the TX/RX data buffer are available on pin SDO_TMDO. The read and write commands are followed by one or more 8-bit data units. Each 8-bit data transmission begins with the MSB.

10.1 Command: Read TX/RX Data Buffer

During a RX operation the user can read the received bytes in the TX/RX data buffer successively.

Figure 10-1. Read TX/RX Data Buffer

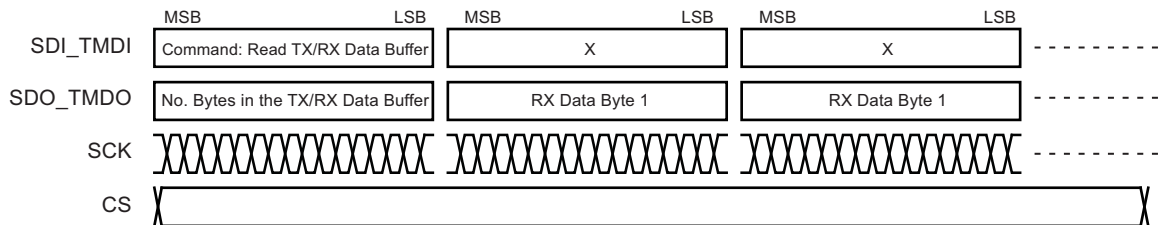

10.2 Command: Write TX/RX Data Buffer

During a TX operation the user can write the bytes in the TX/RX data buffer successively.

Figure 10-2. Write TX/RX Data Buffer

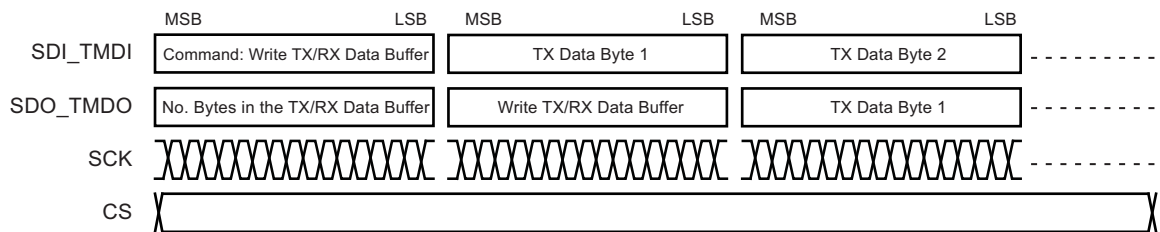

10.3 Command: Read Control/Status Register

The control and status registers can be read individually or successively.

Figure 10-3. Read Control/Status Register

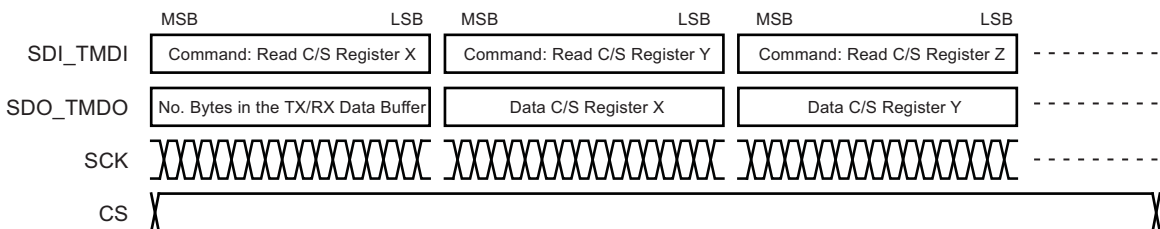

10.4 Command: Write Control Register

The control registers can be written individually or successively.

Figure 10-4. Write Control Register

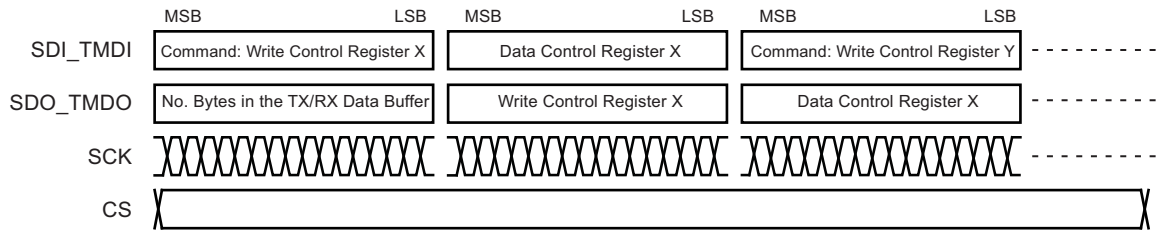

10.5 Command: OFF Command

If the input level on pin PWR_ON is low and on the key input N_PWR_ON is high, the OFF command sets the transceiver to the OFF mode.

Figure 10-5. OFF Command

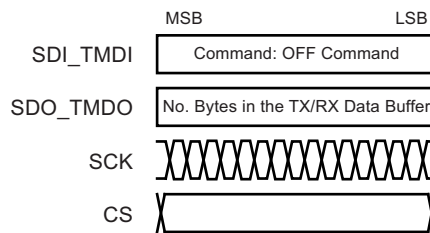

10.6 Command: Delete IRQ

The delete IRQ command sets pin IRQ to low.

Figure 10-6. Delete IRQ

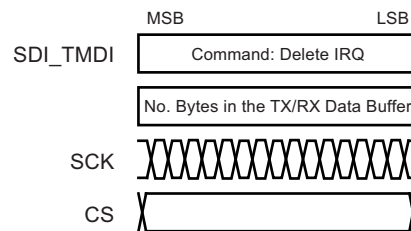

10.7 Command Structure

The three most significant bits of the command (bit 5 to bit 7) indicates the command type. Bit 0 to bit 4 describes the target address when reading or writing to a control or status register.

Bit 0 to bit 4 in the command Write TX/RX Data Buffer defines the value N ($0 \leq N \leq 16$). The TX operation only will be started if the number of bytes in the TX buffer $\geq N$. This function makes sure that the datastream will be sent without gaps. The TX operation only will be started if at least 1 byte are in the TX buffer. This means that $N = 0$ and $N = 1$ have the same function.

In all other commands Bit 0 to Bit 4 have no effect and should be set to 0 for compatibility reasons with future products.

Table 10-1. Command Structure

Command	MSB	Bit 6	Bit 5	Bit 4	Bit 3	Bit 2	Bit 1	LSB
	Bit 7							Bit 0
Read TX/RX data buffer	0	0	0	X	X	X	X	X
Write TX/RX data buffer	0	0	1	N4	N3	N2	N1	N0
Read control/status register	0	1	0	A4	A3	A2	A1	A0
Write control register	0	1	1	A4	A3	A2	A1	A0
OFF command	1	0	0	X	X	X	X	X
Delete IRQ	1	0	1	X	X	X	X	X
Not used	1	1	0	X	X	X	X	X
Not used	1	1	1	X	X	X	X	X

10.8 4-wire Serial Interface

The 4-wire serial interface consists of the Chip Select (CS), the Serial Clock (SCK), the Serial Data Input (SDI_TMDI) and the Serial Data Output (SDO_TMDO). Data is transmitted/received bit by bit in synchronization with the serial clock.

Pin CS_POL defines the active level of the CS:

Table 10-2. Active Level of the CS

CS_POL	Function
0	CS active high
1	CS active low

When CS is inactive and the transceiver is not in RX transparent mode, SDO_TMDO is in a high-impedance state.

Pins SCK_POL and SCK_PHA defines the polarity and the phase of the serial clock SCK.

Figure 10-7. Serial Timing SCK_POL = 0, SCK_PHA = 0

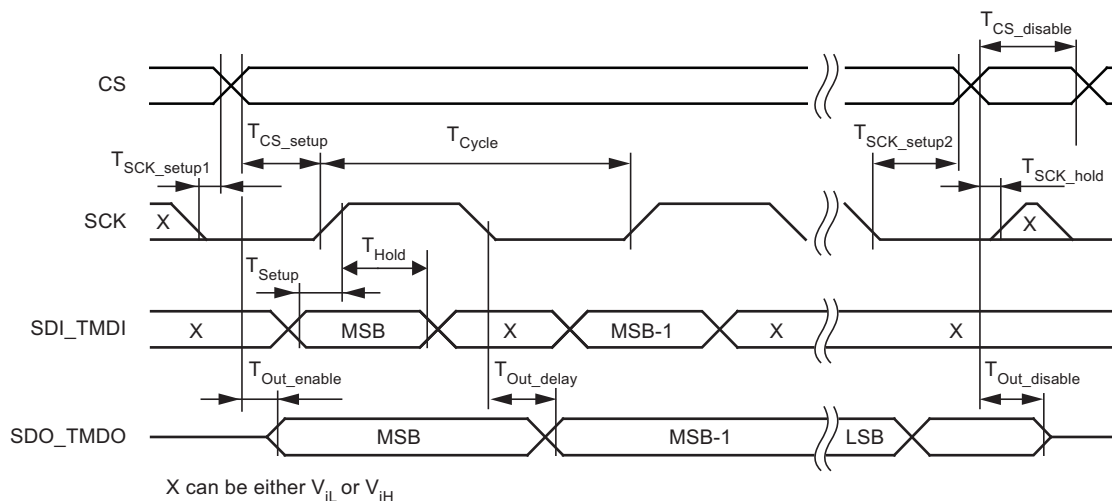

Figure 10-8. Serial Timing SCK_POL = 0, SCK_PHA = 1

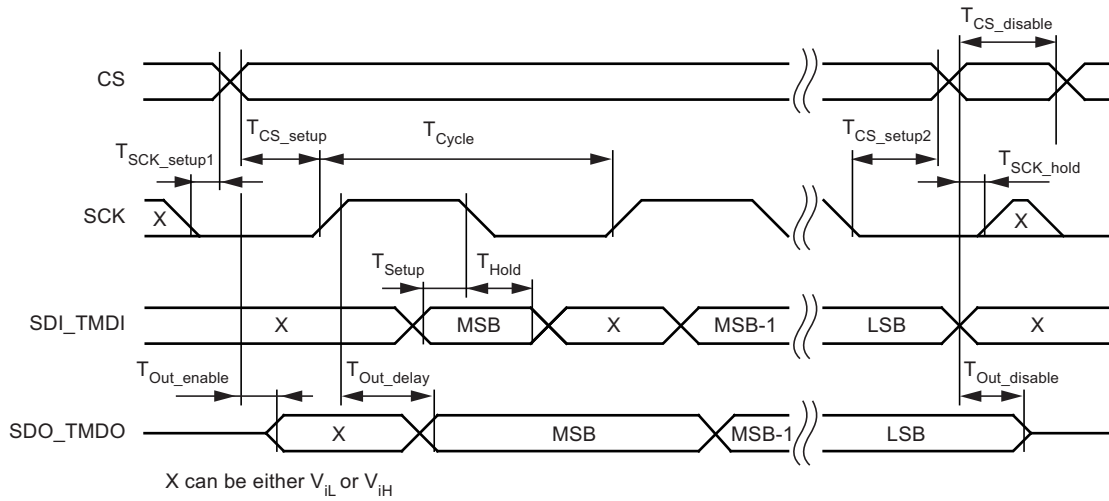

Figure 10-9. Serial Timing SCK_POL = 1, SCK_PHA = 0

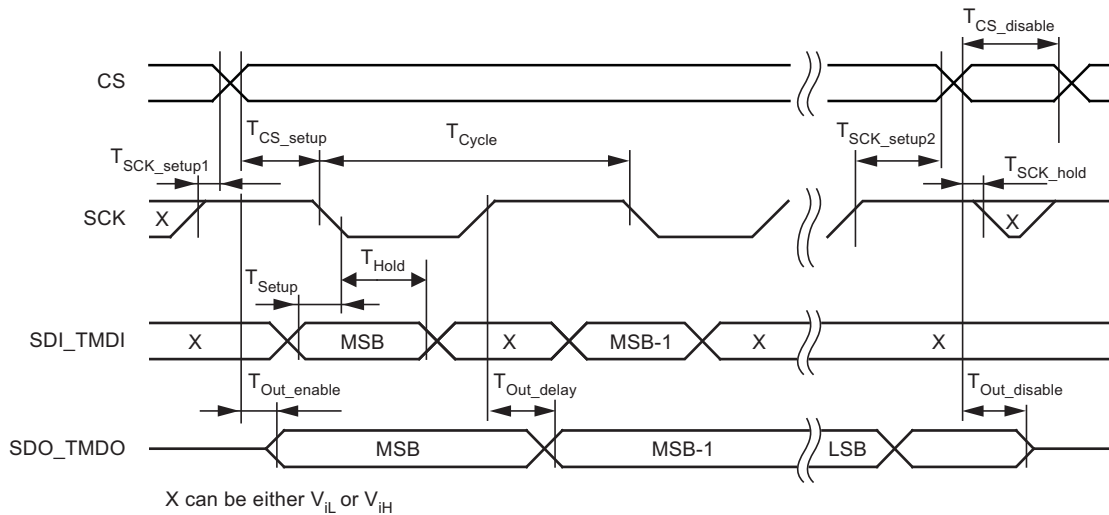
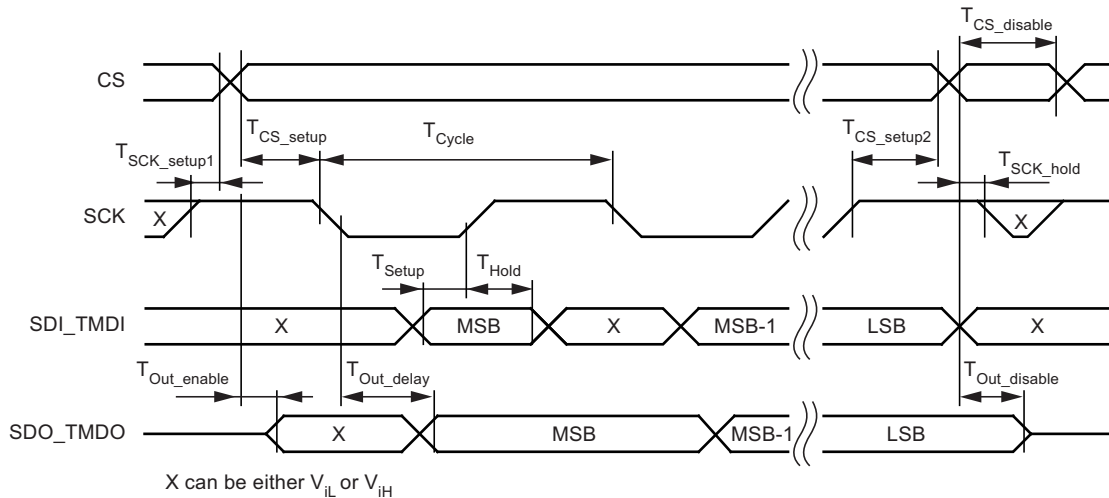

Figure 10-10. Serial Timing SCK_POL = 1, SCK_PHA = 1



11. Operation Modes

11.1 RX Operation

The transceiver is set to RX operation with the bits OPM0, OPM1 and OPM2 in control register 1

Table 11-1. Control Register 1

OPM2	OPM1	OPM0	Function
0	1	0	RX polling mode
0	1	1	RX mode

The transceiver is designed to consume less than 1mA in RX operation while being sensitive to signals from a corresponding transmitter. This is achieved via the polling circuit. This circuits enable the signal path periodically for a short time. During this time the Bit-check logic verifies the presence of a valid transmitter signal. Only if a valid signal is detected the transceiver remains active and transfers the data to the connected microcontroller. This transfer take place either via the TX/RX data buffer or via the pin SDO_TMDO. If there is no valid signal present the transceiver is in sleep mode most of the time resulting in low current consumption. This condition is called RX polling mode. A connected microcontroller can be disabled during this time.

All relevant parameters of the polling logic can be configured by the connected microcontroller. This flexibility enables the user to meet the specifications in terms of current consumption, system response time, data rate etc.

In RX mode the RF transceiver is enabled permanently and the Bit-check logic verifies the presence of a valid transmitter signal. If a valid signal is detected the transceiver transfers the data to the connected microcontroller. This transfer takes place either via the TX/RX data buffer or via the pin SDO_TMDO.

11.1.1 RX Polling Mode

If the transceiver is in RX polling mode, it stays in a continuous cycle of three different modes. In sleep mode, the RF transceiver is disabled for the time period T_{Sleep} while consuming low current of $I_S = I_{IDLE_X}$. During the start-up period, $T_{Startup_PLL}$ and $T_{Startup_Sig_Proc}$, all signal processing circuits are enabled and settled. In the following Bit-check mode, the incoming data stream is analyzed bit by bit versus a valid transmitter signal. If no valid signal is present, the transceiver is set back to sleep mode after the period $T_{Bit-check}$. This period varies check by check as it is a statistical process. An average value for $T_{Bit-check}$ is given in the electrical characteristics. During $T_{Startup_PLL}$ the current consumption is $I_S = I_{RX_X}$. During $T_{Startup_Sig_Proc}$ and $T_{Bit-check}$ the current consumption is $I_S = I_{Startup_Sig_Proc_X}$. The condition of the transceiver is indicated on pin RX_ACTIVE (see Figure 11-1). The average current consumption in RX polling mode I_{Poll} is different in battery application or car application. To calculate I_{Poll} the index X must be replaced by VS1,2 in battery application or VS2 in car application (see section “Electrical Characteristics: General” on page 61).

$$I_{Poll} = \frac{I_{IDLE_X} \times T_{Sleep} + I_{Startup_PLL_X} \times T_{Startup_PLL} + I_{RX_X} \times (T_{Startup_Sig_Proc} + T_{Bitcheck})}{T_{Sleep} + T_{Startup_PLL} + T_{Startup_Sig_Proc} + T_{Bitcheck}}$$

To save current it is recommended CLK be disabled during RX polling mode. I_p does not include the current of the Microcontroller_Interface I_{VSINT} . If CLK is enabled during the RX polling mode the current consumption is calculated as follows:

$$I_{S_Poll} = I_{Poll} + I_{VSINT}$$

During T_{Sleep} , $T_{Startup_PLL}$ and $T_{Startup_Sig_Proc}$ the transceiver is not sensitive to a transmitter signals. To guarantee the reception of a transmitted command the transmitter must start the telegram with an adequate preburst. The required length of the preburst $T_{Presturb}$ depends on the polling parameters T_{Sleep} , $T_{Startup_PLL}$, $T_{Startup_Sig_Proc}$ and $T_{Bit-check}$. Thus, $T_{Bit-check}$ depends on the actual bit rate and the number of bits ($N_{Bit-check}$) to be tested.

$$T_{Presturb} \geq T_{Sleep} + T_{Startup_PLL} + T_{Startup_Sig_Proc} + T_{Bitcheck}$$

11.1.2 Sleep Mode

The length of period T_{Sleep} is defined by the 5-bit word sleep in control register 4, the extension factor X_{Sleep} defined by the bit X_{Sleep} in control register 4 and the basic clock cycle T_{DCLK} . It is calculated to be:

$$T_{\text{Sleep}} = \text{Sleep} \times 1024 \times T_{\text{DCLK}} \times X_{\text{Sleep}}$$

In US and European applications, the maximum value of T_{Sleep} is about 38 ms if X_{Sleep} is set to 1 (which is done by setting the bit X_{Sleep} in control register 4 to 0). The time resolution is about 1.2ms in that case. The sleep time can be extended to about 300 ms by setting X_{Sleep} to 8 (which is done by setting X_{Sleep} in control register 4 to 1), the time resolution is then about 9.6ms.

11.1.3 Start-up Mode

During $T_{\text{Startup_PLL}}$ the PLL is enabled and starts up. If the PLL is locked, the signal processing circuit starts up ($T_{\text{Startup_Sig_Proc}}$). After the start-up time all circuits are in stable condition and ready to receive.

Figure 11-1. Flow Chart RX Polling Mode/RX Mode

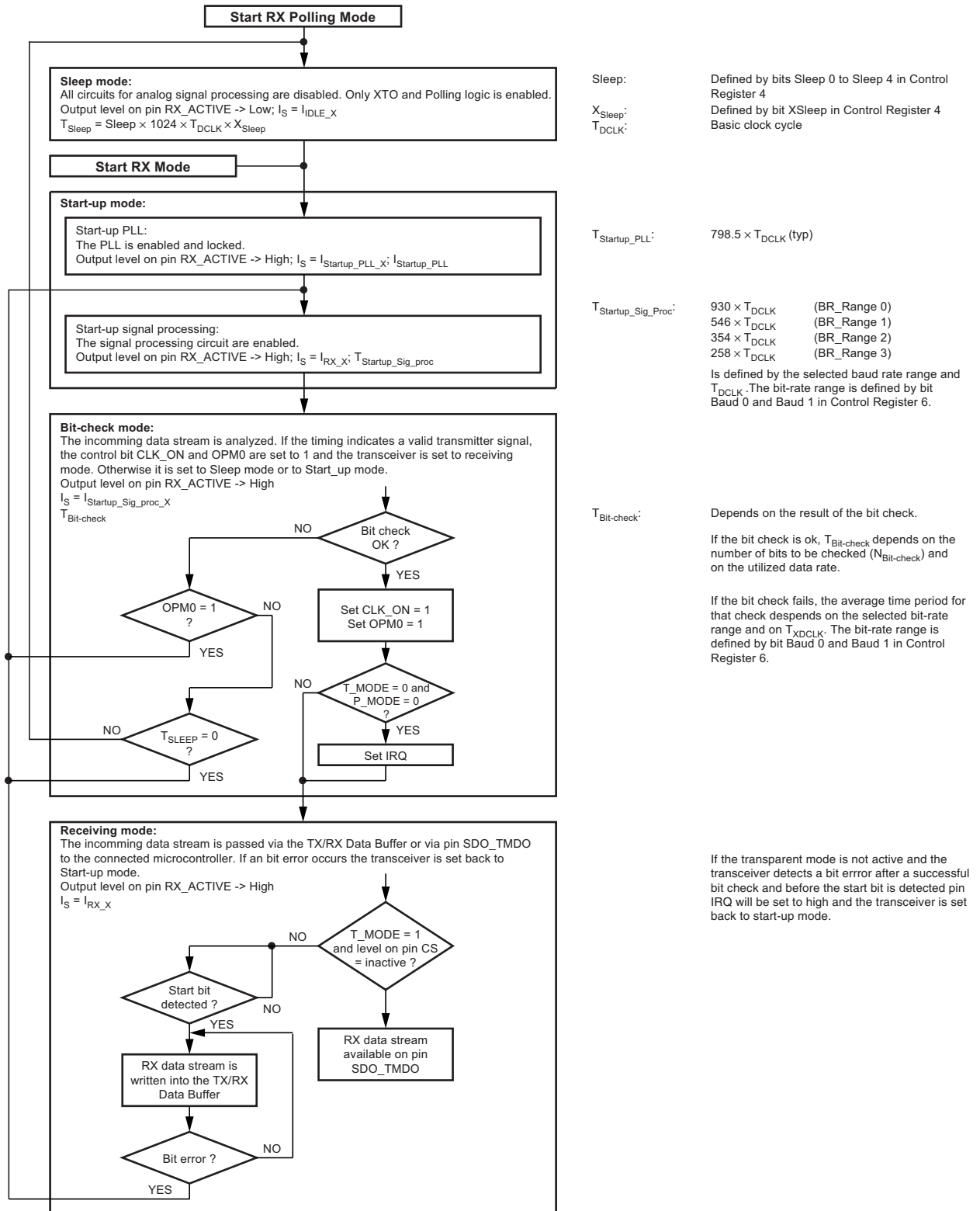

Sleep: Defined by bits Sleep 0 to Sleep 4 in Control Register 4
 X_{Sleep} : Defined by bit XSleep in Control Register 4
 T_{DCLK} : Basic clock cycle

$T_{Startup_PLL}$: $798.5 \times T_{DCLK}$ (typ)

$T_{Startup_Sig_Proc}$:
 $930 \times T_{DCLK}$ (BR_Range 0)
 $546 \times T_{DCLK}$ (BR_Range 1)
 $354 \times T_{DCLK}$ (BR_Range 2)
 $258 \times T_{DCLK}$ (BR_Range 3)
 Is defined by the selected baud rate range and T_{DCLK} . The bit-rate range is defined by bit Baud 0 and Baud 1 in Control Register 6.

$T_{Bit-check}$: Depends on the result of the bit check.
 If the bit check is ok, $T_{Bit-check}$ depends on the number of bits to be checked ($N_{Bit-check}$) and on the utilized data rate.
 If the bit check fails, the average time period for that check depends on the selected bit-rate range and on T_{XDCLK} . The bit-rate range is defined by bit Baud 0 and Baud 1 in Control Register 6.

If the transparent mode is not active and the transceiver detects a bit error after a successful bit check and before the start bit is detected pin IRQ will be set to high and the transceiver is set back to start-up mode.

11.1.4 Bit-check Mode

In Bit-check mode the incoming data stream is examined to distinguish between a valid signal from a corresponding transmitter and signals due to noise. This is done by subsequent time frame checks where the distance between 2 signal edges are continuously compared to a programmable time window. The maximum count of this edge to edge test before the transceiver switches to receiving mode is also programmable.

11.1.5 Bit-check Configuration

Assuming a modulation scheme that contains 2 edges per bit, two time frame checks are verifying one bit. This is valid for Manchester, Bi-phase and most other modulation schemes. The maximum count of bits to be checked can be set to 0, 3, 6 or 9 bits via the variable $N_{\text{Bit-check}}$ in control register 5. This implies 0, 6, 12 and 18 edge to edge checks respectively. If $N_{\text{Bit-check}}$ is set to a higher value, the transceiver is less likely to switch to receiving mode due to noise. In the presence of a valid transmitter signal, the Bit-check takes less time if $N_{\text{Bit-check}}$ is set to a lower value. In RX polling mode, the Bit-check time is not dependent on $N_{\text{Bit-check}}$ if no valid signal is present. Figure 11-2 shows an example where 3 bits are tested successful.

Figure 11-2. Timing Diagram for Complete Successful Bit-check

(Number of checked bits: 3)

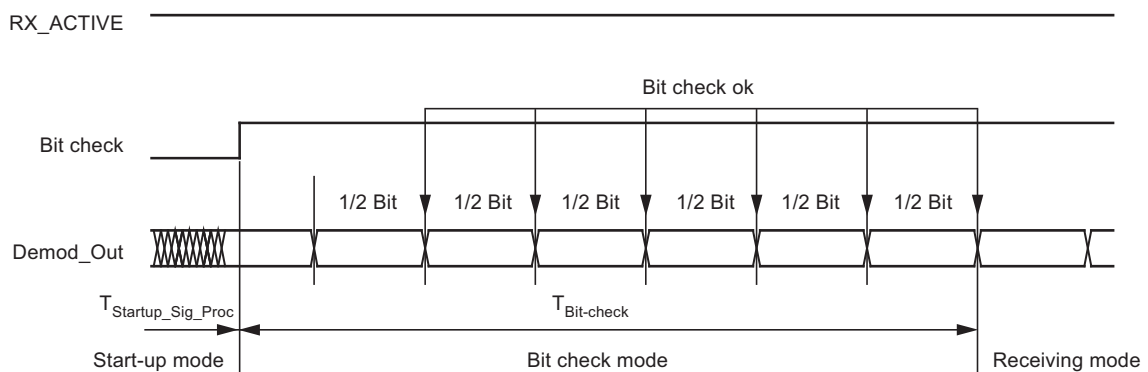

According to Figure 11-3, the time window for the Bit-check is defined by two separate time limits. If the edge to edge time t_{ee} is in between the lower Bit-check limit $T_{\text{Lim_min}}$ and the upper Bit-check limit $T_{\text{Lim_max}}$, the check will be continued. If t_{ee} is smaller than limit $T_{\text{Lim_min}}$ or exceeds $T_{\text{Lim_max}}$, the Bit-check will be terminated and the transceiver switches to sleep mode.

Figure 11-3. Valid Time Window for Bit-check

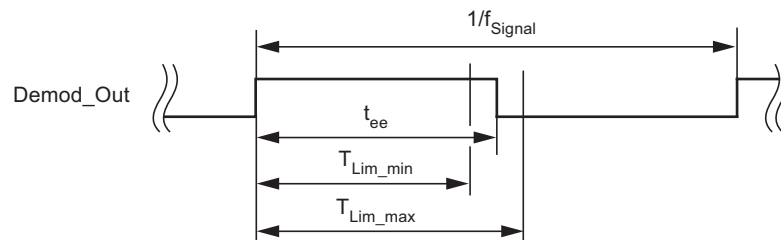

For the best noise immunity it is recommended to use a low span between $T_{\text{Lim_min}}$ and $T_{\text{Lim_max}}$. This is achieved using a fixed frequency at a 50% duty cycle for the transmitter preburst. A "11111..." or a "10101..." sequence in Manchester or bi-phase is a good choice concerning that advice. A good compromise between sensitivity and susceptibility to noise regarding the expected edge to edge time t_{ee} is a time window of $\pm 38\%$. To get the maximum sensitivity the time window should be $\pm 50\%$ and then $N_{\text{Bit-check}} \geq 6$. Using preburst patterns that contain various edge to edge time periods, the Bit-check limits must be programmed according to the required span.

The Bit-check limits are determined by means of the formula below:

$$T_{Lim_min} = Lim_min \times T_{XDCLK}$$

$$T_{Lim_max} = (Lim_max - 1) \times T_{XDCLK}$$

Lim_min is defined by the bits Lim_min 0 to Lim_min 5 in control register 5.

Lim_max is defined by the bits Lim_max 0 to Lim_max 5 in control register 6.

Using the above formulas, Lim_min and Lim_max can be determined according to the required T_{Lim_min} , T_{Lim_max} and T_{XDCLK} . The time resolution defining T_{Lim_min} and T_{Lim_max} is T_{XDCLK} . The minimum edge to edge time t_{ee} is defined according to the section "Receiving Mode" on page 53. The lower limit should be set to $Lim_min \geq 10$. The maximum value of the upper limit is $Lim_max = 63$.

Figure 11-4, Figure 11-5 and Figure 11-6 on page 52 illustrate the Bit-check for the Bit-check limits $Lim_min = 14$ and $Lim_max = 24$. The signal processing circuits are enabled during $T_{Startup_PLL}$ and $T_{Startup_Sig_Proc}$. The output of the ASK/FSK demodulator (Demod_Out) is undefined during that period. When the Bit-check becomes active, the Bit-check counter is clocked with the cycle T_{XDCLK} .

Figure 11-4 shows how the Bit-check proceeds if the Bit-check counter value CV_Lim is within the limits defined by Lim_min and Lim_max at the occurrence of a signal edge. In Figure 11-5 on page 52 the Bit-check fails as the value CV_Lim is lower than the limit Lim_min . The Bit-check also fails if CV_Lim reaches Lim_max . This is illustrated in Figure 11-6 on page 52.

Figure 11-4. Timing Diagram During Bit-check

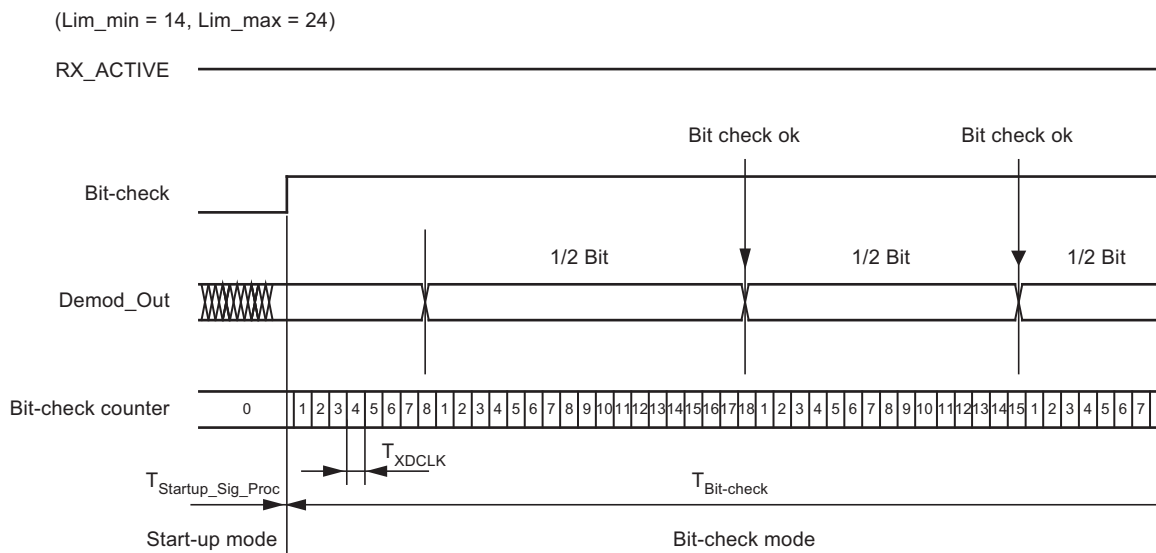

Figure 11-5. Timing Diagram for Failed Bit-check (Condition $CV_Lim < Lim_min$)

($Lim_min = 14, Lim_max = 24$)

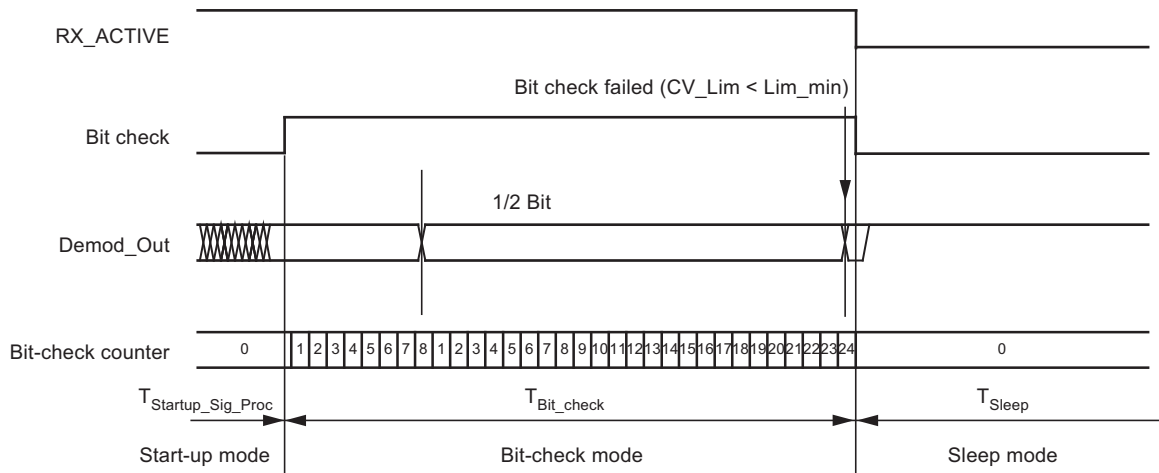
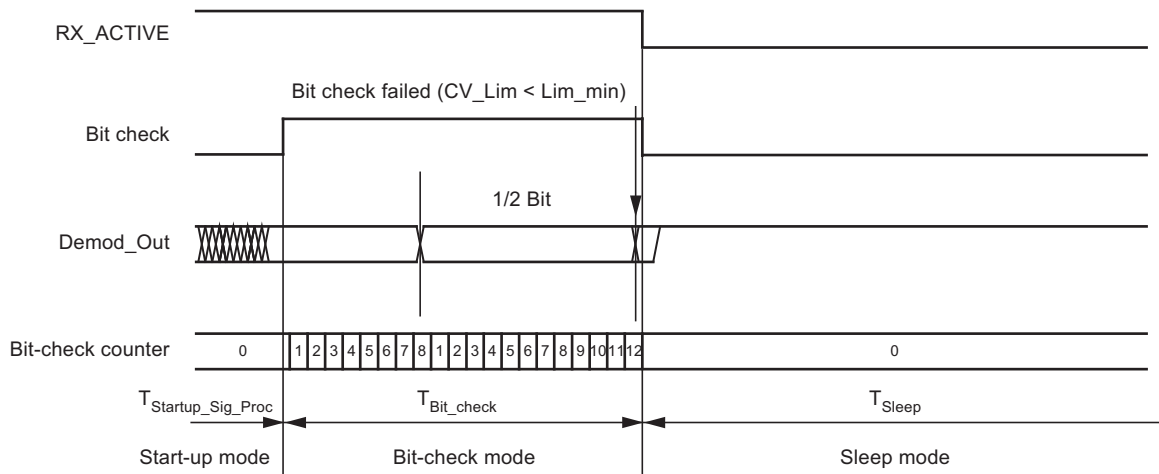

Figure 11-6. Timing Diagram for Failed Bit-check (Condition: $CV_Lim \geq Lim_max$)

($Lim_min = 14, Lim_max = 24$)



11.1.6 Duration of the Bit-check

If no transmitter is present during the Bit-check, the output of the ASK/FSK demodulator delivers random signals. The Bit-check is a statistical process and T_{Bit_check} varies for each check. Therefore, an average value for T_{Bit_check} is given in the electrical characteristics. T_{Bit_check} depends on the selected bit-rate range and on T_{XDCLK} . A higher bit-rate range causes a lower value for T_{Bit_check} resulting in a lower current consumption in RX polling mode.

In the presence of a valid transmitter signal, T_{Bit_check} is dependent on the frequency of that signal, f_{Signal} , and the count of the bits, N_{Bit_check} . A higher value for N_{Bit_check} thereby results in a longer period for T_{Bit_check} requiring a higher value for the transmitter pre-burst $T_{Preburst}$.

11.1.7 Receiving Mode

If the Bit-check was successful for all bits specified by $N_{\text{Bit-check}}$, the transceiver switches to receiving mode. To activate a connected microcontroller, bit CLK_ON in control register 3 is set to 1. An interrupt is issued at pin IRQ if the control bits T_MODE = 0 and P_MODE = 0.

If the transparent mode is active (T_MODE = 1) and the level on pin CS is inactive (no data transfer via the serial interface), the RX data stream is available on pin SDO_TMDO (Figure 11-7).

Figure 11-7. Receiving Mode (TMODE = 1)

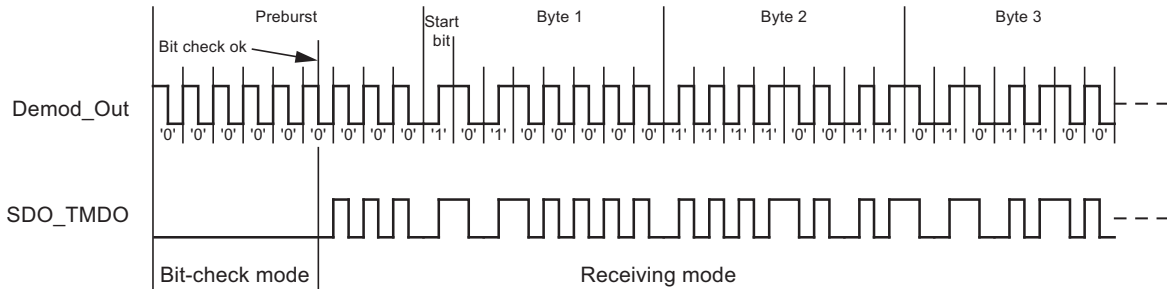

If the transparent mode is inactive (T_MODE = 0), the received data stream is buffered in the TX/RX data buffer (see Figure 11-8 on page 54). The TX/RX data buffer is only usable for Manchester and Bi-phase coded signals. It is permanently possible to transfer the data from the data buffer via the 4-wire serial interface to a microcontroller (see Figure 10-1 on page 43).

Buffering of the data stream:

After a successful Bit-check, the transceiver switches from Bit-check mode to receiving mode. In receiving mode the TX/RX data buffer control logic is active and examines the incoming data stream. This is done, like in the Bit-check, by subsequent time frame checks where the distance between two edges is continuously compared to a programmable time window as illustrated in Figure 11-8 on page 54. Only two distances between two edges in Manchester and Bi-phase coded signals are valid (T and 2T).

The limits for T are the same as used for the Bit-check. They can be programmed in control register 5 and 6 (Lim_min, Lim_max).

The limits for 2T are calculated as follows:

Lower limit of 2T:

$$\text{Lim_min_2T} = (\text{Lim_min} + \text{Lim_max}) - (\text{Lim_max} - \text{Lim_min})/2$$

$$T_{\text{Lim_min_2T}} = \text{Lim_min_2T} \times T_{\text{XDCLK}}$$

Upper limit of 2T:

$$\text{Lim_max_2T} = (\text{Lim_min} + \text{Lim_max}) + (\text{Lim_max} - \text{Lim_min})/2$$

$$T_{\text{Lim_max_2T}} = (\text{Lim_max_2T} - 1) \times T_{\text{XDCLK}}$$

If the result of Lim_min_2T or Lim_max_2T is not an integer value, it will be round up.

If the TX/RX data buffer control logic detects the start bit, the data stream is written in the TX/RX data buffer byte by byte. The start bit is part of the first data byte and must be different from the bits of the preburst. If the preburst consists of a sequence of "00000...", the start bit must be a 1. If the preburst consists of a sequence of "11111...", the start bit must be a 0.

If the data stream consists of more than 16 bytes, a buffer overflow occurs and the TX/RX data buffer control logic overwrites the bytes already stored in the TX/RX data buffer. So it is very important to ensure that the data is read in time so that no buffer overflow occurs in that case (see Figure 10-1 on page 43). There is a counter that indicates the number of received bytes in the TX/RX data buffer (see section "Transceiver Configuration" on page 43). If a byte is transferred to the microcontroller, the counter is decremented, if a byte is received, the counter is incremented. The counter value is available via the 4-wire serial interface.

An interrupt is issued if the counter while counting forwards reaches the value defined by the control bits IR0 and IR1 in control register 1.

11.1.8 Recommended Lim_min and Lim_max for Maximum Sensitivity

The sensitivity measurement in the section “Low-IF Receiver” on page 9, in Table 5-3 and Table 5-4 on page 10 have been done with the Lim_min and Lim_max values according to Table 11-3. These values are optimized for maximum sensitivity. Note that since these Limits are optimized for sensitivity the number of checked bit $N_{\text{Bit-check}}$ has to be at least 6 to prevent the circuit from waking up too often in polling mode due to noise.

Table 11-3. Recommended Lim_min and Lim_max Values for Different Bit Rates

f_{RF} (f_{XTAL})/MHz	1.0Kbit/s BR_Range_0 XLim = 1	2.4Kbit/s BR_Range_0 XLim = 0	5Kbit/s BR_Range_1 XLim = 0	10Kbit/s BR_Range_2 XLim = 0	20Kbit/s BR_Range_3 XLim = 0
315 (12.73193)	Lim_min = 13 (251µs) Lim_max = 38 (715µs)	Lim_min = 12 (121µs) Lim_max = 34 (332µs)	Lim_min = 11 (55µs) Lim_max = 32 (156µs)	Lim_min = 11 (28µs) Lim_max = 32 (78µs)	Lim_min = 11 (14µs) Lim_max = 32 (39µs)
433.92 (13.25311)	Lim_min = 13 (251µs) Lim_max = 38 (715µs)	Lim_min = 11 (106µs) Lim_max = 32 (299µs)	Lim_min = 11 (53µs) Lim_max = 32 (150µs)	Lim_min = 11 (27µs) Lim_max = 32 (75µs)	Lim_min = 11 (13µs) Lim_max = 32 (37µs)

11.2 TX Operation

The transceiver is set to TX operation by using the bits OPM0, OPM1 and OPM2 in the control register 1.

Table 11-4. Control Register 1

OPM2	OPM1	OPM0	Function
0	0	1	TX mode

Before activating the TX mode, the TX parameters (bit rate, modulation scheme...) must be selected as illustrated in Figure 11-10 on page 56. The bit rate depends on Baud0 and Baud1 in control register 6 and TX0 to TX5 in control register 7 (see section “Control Register” on page 33). The modulation is selected with ASK_NFSK in control register 4. The FSK frequency deviation is fixed to about $\pm 19\text{kHz}$ (see Table 6-1 on page 25). If P_Mode is set to 1, the Manchester modulator is disabled and pattern mode is active (NRZ, see Table 11-5 on page 58).

After the transceiver is set to TX mode the start-up mode is active and the PLL is enabled. If the PLL is locked, the TX mode is active.

If the transceiver is in start-up or TX mode, the TX/RX data buffer can be loaded via the 4-wire serial interface. After N bytes are in the buffer and the TX mode is active, the transceiver starts transmitting automatically (beginning with the MSB). Bit 0 to Bit 4 in the command Write TX/RX Data Buffer defines the value N ($0 \leq N \leq 16$; see section “Command Structure” on page 45). While transmitting, it is permanently possible to load new data in the TX/RX data buffer. To prevent a buffer overflow or interruptions during transmitting the user must ensure that data is loaded at the same speed as it is transmitted.

There is a counter that indicates the number of bytes to be transmitted (see section “Transceiver Configuration” on page 43). If a byte is loaded, the counter is incremented, if a byte is transmitted, the counter is decremented. The counter value is available via the 4-wire serial interface. An IRQ is issued if the counter reaches the value defined by the control bits IR0 and IR1 in control register 1.

Note: Writing to the control register 1, 4, 5, 6 or 7 during TX mode, resets the TX/RX data buffer and the counter which indicates the number of bytes to be transmitted.

If T_Mode in control register 1 is set to 1, the transceiver is in TX transparent mode. In this mode the TX/RX data buffer is disabled and the TX data stream must be applied on pin SDI_TMDI. Figure 11-10 on page 56 illustrates the flow chart of the TX transparent mode.

Figure 11-10. TX Operation (T_MODE = 0)

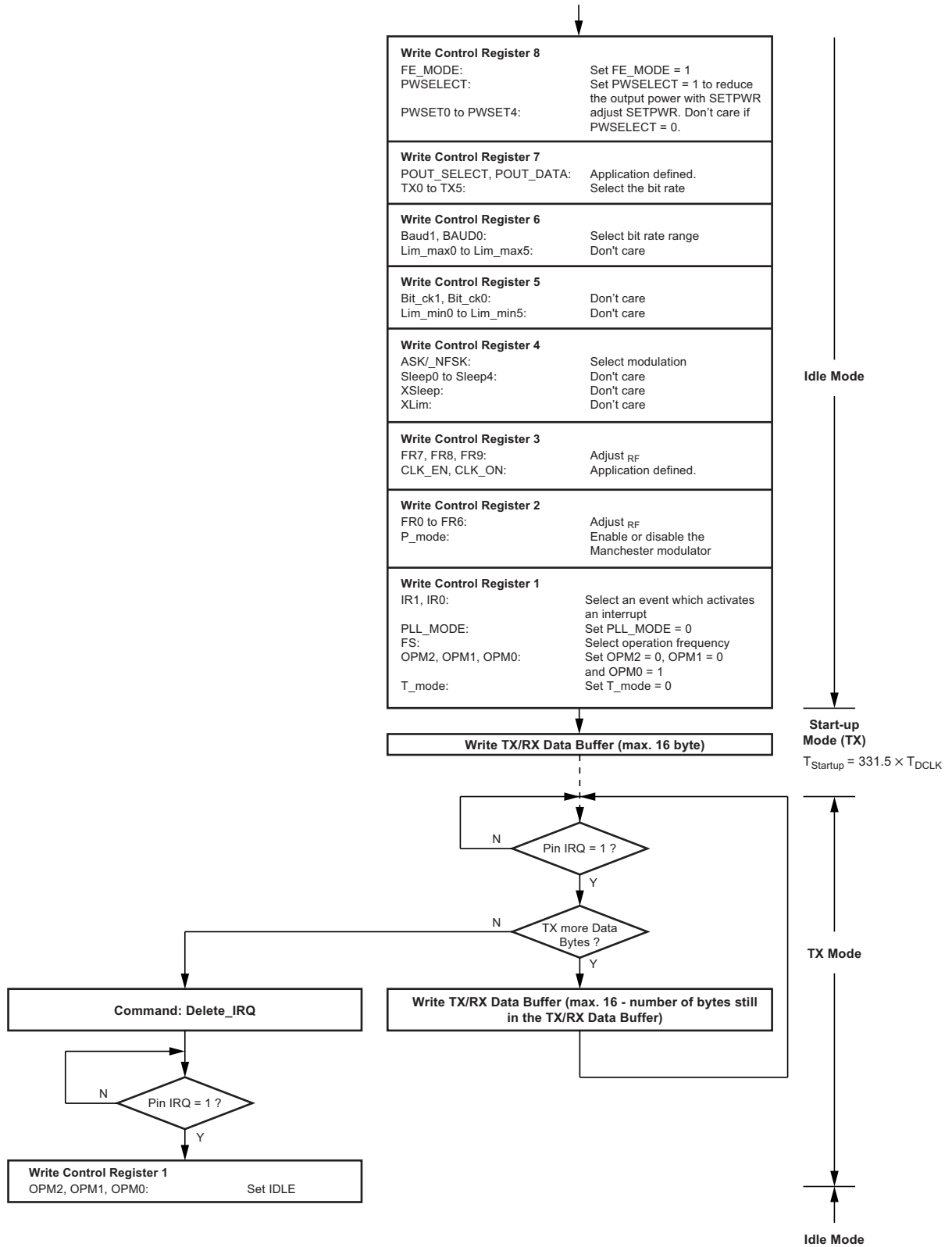

Figure 11-11. TX Transparent Mode (T_MODE = 1)

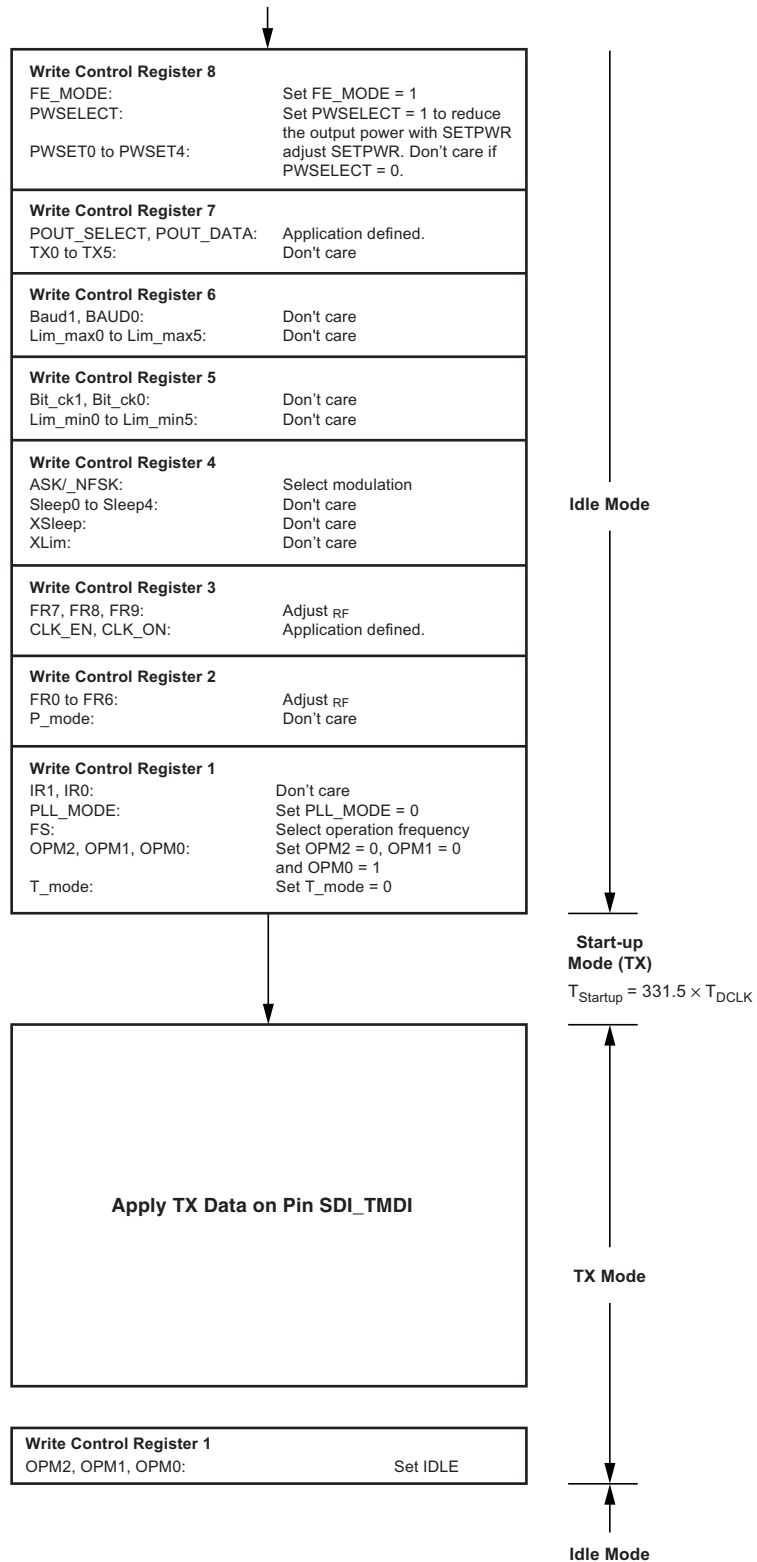

Table 11-5. TX Modulation Schemes

Mode	ASK/_NFSK	P_Mode	T_Mode	Bit in TX/RX Data Buffer	Level on Pin SDI_TMDI	RF _{OUT}
TX	0	0	0	1	X	f _{FSK_L} → f _{FSK_H}
		0	0	0	X	f _{FSK_H} → f _{FSK_L}
		1	0	1	X	f _{FSK_H}
		1	0	0	X	f _{FSK_L}
		X	1	X	1	f _{FSK_H}
		X	1	X	0	f _{FSK_L}
	1	0	0	1	X	f _{ASK off} → f _{ASK on}
		0	0	0	X	f _{ASK on} → f _{ASK off}
		1	0	1	X	f _{ASK on}
		1	0	0	X	f _{ASK off}
		X	1	X	1	f _{ASK on}
		X	1	X	0	f _{ASK off}

11.3 Interrupts

Via pin IRQ, the transceiver signals different operating conditions to a connected microcontroller. If a specific operating condition occurs, pin IRQ is set to a high level.

If an interrupt occurs, it is recommended to delete the interrupt immediately by reading the status register, thus the next possible interrupt doesn't get lost. If the Interrupt pin doesn't switch to a low level by reading the status register, the interrupt was triggered by the RX/TX data buffer. In this case, read or write the RX/TX data buffer according to [Table 11-6](#).

Table 11-6. Interrupt Handling

Operating Conditions Which Sets Pin IRQ to High Level	Operations Which Sets Pin IRQ to Low Level
Events in Status Register	
State transition of status bit N_Power_On (0 → 1; 1 → 0)	Read status register or Command delete IRQ
Appearance of status bit Power_On (0 → 1)	
Events During TX Operation (T_MODE = 0)	
1, 2, 4 or 12 bytes are in the TX data buffer or the TX data buffer is empty (depends on IR0 and IR1 in control register 1)	Write TX data buffer or Write control register 1 or Write control register 4 or Write control register 5 or Write control register 6 or Write control register 7 or Command delete IRQ

Note: 1. During reading of the RX/TX buffer, no IRQ is issued, due to the received bytes or a receiving error.

Table 11-6. Interrupt Handling (Continued)

Operating Conditions Which Sets Pin IRQ to High Level	Operations Which Sets Pin IRQ to Low Level
Events During RX Operation (T_MODE = 0)	
1, 2, 4 or 12 received bytes are in the RX data buffer or a receiving error is occurred (depends on IR0 and IR1 in control register 1)	Read RX data buffer ⁽¹⁾ or Write control register 1 or Write control register 4 or Write control register 5 or Write control register 6 or Write control register 7 or Command delete IRQ
Successful Bit-check (P_MODE = 0)	
Events During FD Operation	
TX data buffer empty	Read RX data buffer ⁽¹⁾ or Write control register 1 or Write control register 4 or Write control register 5 or Write control register 6 or Write control register 7 or Command delete IRQ

Note: 1. During reading of the RX/TX buffer, no IRQ is issued, due to the received bytes or a receiving error.

12. Absolute Maximum Ratings

Stresses beyond those listed under “Absolute Maximum Ratings” may cause permanent damage to the device. This is a stress rating only and functional operation of the device at these or any other conditions beyond those indicated in the operational sections of this specification is not implied. Exposure to absolute maximum rating conditions for extended periods may affect device reliability.

Parameters	Symbol	Min.	Max.	Unit
Junction temperature	T_j		150	°C
Storage temperature	T_{stg}	-55	+125	°C
Ambient temperature	T_{amb}	-40	+105	°C
Supply voltage VS2	V_{MaxVS2}	-0.3	+7.2	V
Supply voltage VS1	V_{MaxVS1}	-0.3	+4	V
Supply voltage VSINT	$V_{MaxVSINT}$	-0.3	+5.5	V
ESD (Human Body Model ESD S.5.1) every pin	HBM	-2.5	+2.5	kV
ESD (Machine Model JEDEC A115A) every pin	MM	-200	+200	V
ESD (Field Induced Charge Device Model ESD STM 5.3.1-1999) every pin	FCDM	-500	500	V
Maximum input level, input matched to 50Ω	P_{in_max}		10	dBm

13. Thermal Resistance

Parameters	Symbol	Value	Unit
Junction ambient	R_{thJA}	25	K/W

14. Electrical Characteristics: General

All parameters refer to GND and are valid for $T_{amb} = -40^{\circ}\text{C}$ to $+105^{\circ}\text{C}$, $V_{VS1} = V_{VS2} = V_{VSINT} = 2.15\text{V}$ to 3.6V (battery application), and $V_{VS2} = 4.4\text{V}$ to 5.6V , $V_{VSINT} = 4.4\text{V}$ to 5.25V (car application). Typical values are given at $V_{VS1} = V_{VS2} = V_{VSINT} = 3\text{V}$ and $T_{amb} = 25^{\circ}\text{C}$, $f_{RF} = 433.92\text{MHz}$ (battery application) unless otherwise specified. Details about current consumption, timing and digital pin properties can be found in the specific sections of the “Electrical Characteristics”.

No.	Parameters	Test Conditions	Pin ⁽¹⁾	Symbol	Min.	Typ.	Max.	Unit	Type*
1 RX_TX_IDLE Mode									
1.1	RF operating frequency range	Atmel ATA5824 $V_{433_N868} = AVCC$	4, 10	f_{RF}	433		435	MHz	A
		ATA5823 $V_{433_N868} = AVCC$	4, 10	f_{RF}	314		316	MHz	A
1.2	Supply current OFF mode	$V_{VS1} = V_{VS2} = V_{VSINT} = 3\text{V}$ (battery)	17, 18, 27	I_{S_OFF}		< 10		nA	A
		$V_{VS2} = V_{VSINT} = 5\text{V}$ (car)	17, 27	I_{S_OFF}		< 10		nA	A
1.3	Supply current IDLE mode	XTO running $V_{VS1} = V_{VS2} = V_{VSINT} = 3\text{V}$ (battery) CLK disabled	17, 18, 27	I_{S_IDLE}		260		μA	B
		XTO running $V_{VS2} = V_{VSINT} = 5\text{V}$ (car) CLK disabled	17, 27	I_{S_IDLE}		350		μA	B
1.4	System start-up time	From OFF mode to IDLE mode including reset and XTO start-up (see Figure 9-4 on page 42) XTAL: $C_m = 5\text{fF}$, $C_0 = 1.8\text{pF}$, $R_m = 15\Omega$		$T_{PWR_ON_IRQ_1}$		0.3		ms	C
1.5	RX start-up time	From IDLE mode to receiving mode $N_{\text{Bit-check}} = 3$ Bit rate = 20Kbit/s, BR_Range_3 (see Figure 11-1 on page 49 and Figure 11-2 on page 50)		$T_{\text{Startup_PLL}} + T_{\text{Startup_Sig_Proc}} + T_{\text{Bit-check}}$		1.39		ms	A
1.6	TX start-up time	From IDLE mode to TX mode (see Figure 11-10 on page 56)		T_{Startup}		0.4		ms	A

*) Type means: A = 100% tested, B = 100% correlation tested, C = Characterized on samples, D = Design parameter

Note: 1. Pin numbers in brackets mean they were measured with RF_IN matched to 50Ω according to [Figure 5-1 on page 10](#) with component values according to [Table 5-2 on page 10](#) (RF_IN) and RF_OUT matched to 50Ω according to [Figure 5-12 on page 20](#) with component values according to [Table 5-7 on page 20](#) (RF_OUT).

14. Electrical Characteristics: General (Continued)

All parameters refer to GND and are valid for $T_{amb} = -40^{\circ}\text{C}$ to $+105^{\circ}\text{C}$, $V_{VS1} = V_{VS2} = V_{VSINT} = 2.15\text{V}$ to 3.6V (battery application), and $V_{VS2} = 4.4\text{V}$ to 5.6V , $V_{VSINT} = 4.4\text{V}$ to 5.25V (car application). Typical values are given at $V_{VS1} = V_{VS2} = V_{VSINT} = 3\text{V}$ and $T_{amb} = 25^{\circ}\text{C}$, $f_{RF} = 433.92\text{MHz}$ (battery application) unless otherwise specified. Details about current consumption, timing and digital pin properties can be found in the specific sections of the “Electrical Characteristics”.

No.	Parameters	Test Conditions	Pin ⁽¹⁾	Symbol	Min.	Typ.	Max.	Unit	Type*
2 Receiver/RX Mode									
2.1	Supply current RX mode	$f_{RF} = 433.92\text{MHz}$ and $f_{RF} = 315\text{MHz}$	17, 18, 27	I_{S_RX}		10.5		mA	A
2.2	Supply current RX polling mode	$T_{Sleep} = 49.45\text{ms}$ $X_{SLEEP} = 8$, Sleep = 5 Bit rate = 20Kbit/s FSK, CLK disabled	17, 18, 27	I_{S_Poll}		484		μA	C
2.3	Input sensitivity FSK $f_{RF} = 433.92\text{MHz}$	FSK deviation $f_{DEV} = \pm 19.5\text{kHz}$ limits according to Table 11-3 on page 55 , BER = 10^{-3} $T_{amb} = 25^{\circ}\text{C}$							
		Bit rate 20Kbit/s	(4)	S_{REF_FSK}	-103.5	-105.5	-107.0	dBm	B
		Bit rate 2.4Kbit/s	(4)	S_{REF_FSK}	-107.0	-109.0	-110.5	dBm	B
2.4	Input sensitivity ASK $f_{RF} = 433.92\text{MHz}$	ASK 100% level of carrier, limits according to Table 11-3 on page 55 , BER = 10^{-3} $T_{amb} = 25^{\circ}\text{C}$							
		Bit rate 10Kbit/s	(4)	P_{REF_ASK}	-109.5	-111.5	-113.0	dBm	B
		Bit rate 2.4Kbit/s	(4)	P_{REF_ASK}	-113.5	-115.5	-117.0	dBm	B
2.5	Sensitivity change at $f_{RF} = 315\text{MHz}$ compared to $f_{RF} = 433.92\text{MHz}$	$f_{RF} = 433.92\text{MHz}$ to $f_{RF} = 315\text{MHz}$ $f_{RF} = 433.92\text{MHz}$ to $S = S_{REF_ASK} + \Delta S_{REF1}$ $S = S_{REF_FSK} + \Delta S_{REF1}$	(4)	ΔS_{REF1}		-1.0 +2.7		dB	B
2.6	Sensitivity change versus temperature, supply voltage and frequency offset	FSK $f_{DEV} = \pm 19.5\text{kHz}$ $\Delta f_{OFFSET} \leq \pm 75\text{kHz}$ ASK 100% $\Delta f_{OFFSET} \leq \pm 75\text{kHz}$ $S = S_{REF_ASK} + \Delta S_{REF1} + \Delta S_{REF2}$ $S = S_{REF_FSK} + \Delta S_{REF1} + \Delta S_{REF2}$	(4)	ΔS_{REF2}	+4.5		-1.5		B

*) Type means: A = 100% tested, B = 100% correlation tested, C = Characterized on samples, D = Design parameter

Note: 1. Pin numbers in brackets mean they were measured with RF_IN matched to 50Ω according to [Figure 5-1 on page 10](#) with component values according to [Table 5-2 on page 10](#) (RF_IN) and RF_OUT matched to 50Ω according to [Figure 5-12 on page 20](#) with component values according to [Table 5-7 on page 20](#) (RF_OUT).

14. Electrical Characteristics: General (Continued)

All parameters refer to GND and are valid for $T_{amb} = -40^{\circ}\text{C}$ to $+105^{\circ}\text{C}$, $V_{VS1} = V_{VS2} = V_{VSINT} = 2.15\text{V}$ to 3.6V (battery application), and $V_{VS2} = 4.4\text{V}$ to 5.6V , $V_{VSINT} = 4.4\text{V}$ to 5.25V (car application). Typical values are given at $V_{VS1} = V_{VS2} = V_{VSINT} = 3\text{V}$ and $T_{amb} = 25^{\circ}\text{C}$, $f_{RF} = 433.92\text{MHz}$ (battery application) unless otherwise specified. Details about current consumption, timing and digital pin properties can be found in the specific sections of the “Electrical Characteristics”.

No.	Parameters	Test Conditions	Pin ⁽¹⁾	Symbol	Min.	Typ.	Max.	Unit	Type*
2.7	RSSI output	Dynamic range	(4), 36	D_{RSSI}		70		dB	A
		Lower level of range $f_{RF} = 315\text{MHz}$ $f_{RF} = 433.92\text{MHz}$	(4), 36	P_{RFIN_Low}		-116 -115		dBm dBm	A
		Upper level of range $f_{RF} = 315\text{MHz}$ $f_{RF} = 433.92\text{MHz}$	(4), 36	P_{RFIN_High}		-46 -45		dBm dBm	A
		Gain	(4), 36		5.5	8.0	10.5	mV/dB	A
		Output voltage range	(4), 36	OV_{RSSI}	350		1100	mV	A
2.8	Output resistance RSSI pin	RX mode TX mode	36	R_{RSSI}	8 32	10 40	12.5 50	k Ω	C
2.9	Maximum frequency offset in FSK mode	Maximum frequency difference of f_{RF} between receiver and transmitter in FSK mode (f_{RF} is the center frequency of the FSK signal with $f_{DEV} = \pm 19.5\text{kHz}$) $P_{RF_IN} \leq +10\text{dBm}$ $P_{RF_IN} \leq P_{RFIN_High}$ (see Figure 5-2 on page 11)	(4)	$\Delta f_{OFFSET1}$ $\Delta f_{OFFSET2}$	-69 -75		+69 +75	kHz	B
2.10	Supported FSK frequency deviation	With up to 2dB loss of sensitivity. Note that the tolerable frequency offset is for $f_{DEV} = \pm 28\text{kHz}$, 8.5kHz lower than for $f_{DEV} = \pm 19.5\text{kHz}$ hence $\Delta f_{OFFSET2} = \pm 66.5\text{kHz}$	(4)	f_{DEV}	± 14	± 19.5	± 28	kHz	B
2.11	System noise figure	$f_{RF} = 315\text{MHz}$	(4)	NF		5.5		dB	B
		$f_{RF} = 433.92\text{MHz}$	(4)	NF		6.5		dB	B
2.12	Intermediate frequency	$f_{RF} = 315\text{MHz}$		f_{IF}		227		kHz	A
		$f_{RF} = 433.92\text{MHz}$		f_{IF}		223		kHz	A
2.13	System bandwidth	This value is for information only! Note that for crystal and system frequency offset calculations, Δf_{OFFSET} must be used.	(4)	SBW		220		kHz	A
2.14	System out-band 2 nd -order input intercept point with respect to f_{IF}	$\Delta f_{meas1} = 1.800\text{MHz}$ $\Delta f_{meas2} = 2.026\text{MHz}$ $f_{IF} = \Delta f_{meas2} - \Delta f_{meas1}$	(4)	IIP2		+50		dBm	C

*) Type means: A = 100% tested, B = 100% correlation tested, C = Characterized on samples, D = Design parameter

Note: 1. Pin numbers in brackets mean they were measured with RF_IN matched to 50 Ω according to [Figure 5-1 on page 10](#) with component values according to [Table 5-2 on page 10](#) (RF_IN) and RF_OUT matched to 50 Ω according to [Figure 5-12 on page 20](#) with component values according to [Table 5-7 on page 20](#) (RF_OUT).

14. Electrical Characteristics: General (Continued)

All parameters refer to GND and are valid for $T_{amb} = -40^{\circ}\text{C}$ to $+105^{\circ}\text{C}$, $V_{VS1} = V_{VS2} = V_{VSINT} = 2.15\text{V}$ to 3.6V (battery application), and $V_{VS2} = 4.4\text{V}$ to 5.6V , $V_{VSINT} = 4.4\text{V}$ to 5.25V (car application). Typical values are given at $V_{VS1} = V_{VS2} = V_{VSINT} = 3\text{V}$ and $T_{amb} = 25^{\circ}\text{C}$, $f_{RF} = 433.92\text{MHz}$ (battery application) unless otherwise specified. Details about current consumption, timing and digital pin properties can be found in the specific sections of the “Electrical Characteristics”.

No.	Parameters	Test Conditions	Pin ⁽¹⁾	Symbol	Min.	Typ.	Max.	Unit	Type*
2.15	System outband 3 rd -order input intercept point	$\Delta f_{meas1} = 1.8\text{MHz}$ $\Delta f_{meas2} = 3.6\text{MHz}$ $f_{RF} = 315\text{MHz}$	(4)	IIP3		-22		dBm	C
		$f_{RF} = 433.92\text{MHz}$	(4)	IIP3		-21		dBm	C
2.16	System outband input 1dB compression point	$\Delta f_{meas1} = 10\text{MHz}$ $f_{RF} = 315\text{MHz}$ this values are for information only, for blocking behavior see Figure 5-3 on page 13 to Figure 5-7 on page 15	(4)	I1dBCP		-31		dBm	C
		$f_{RF} = 433.92\text{MHz}$	(4)	I1dBCP		-30		dBm	C
2.17	LNA input impedance	$f_{RF} = 315\text{MHz}$	4	Z_{in_LNA}		(44 - j233)		Ω	C
		$f_{RF} = 433.92\text{MHz}$	4	Z_{in_LNA}		(32 - j169)		Ω	C
2.18	Allowable peak RF input level, ASK and FSK	$\text{BER} < 10^{-3}$, ASK: 100%	(4)	P_{IN_max}		+10	-10	dBm	C
		FSK: $f_{DEV} = \pm 19.5\text{kHz}$	(4)	P_{IN_max}		+10	-10	dBm	C
2.19	LO spurious at LNA_IN	$f < 1\text{GHz}$	(4)				-57	dBm	C
		$f > 1\text{GHz}$	(4)				-47	dBm	C
		$f_{RF} = 315\text{MHz}$	(4)				-100	dBm	C
		$f_{RF} = 433.92\text{MHz}$	(4)				-98	dBm	C
2.20	Image rejection	Within the complete image band $f_{RF} = 315\text{MHz}$	(4)		25	30		dB	A
		$f_{RF} = 433.92\text{MHz}$	(4)		25	30		dB	A
2.21	Useful signal to interferer ratio	Peak level of useful signal to peak level of interferer for $\text{BER} < 10^{-3}$ with any modulation scheme of interferer.							
		FSK BR_Ranges 0, 1, 2	(4)	$\text{SNR}_{\text{FSK0-2}}$		2	3	dB	B
		FSK BR_Range_3	(4)	SNR_{FSK3}		4	6	dB	B
		ASK ($P_{RF} < P_{RFIN_High}$)	(4)	SNR_{ASK}		10	12	dB	B
2.22	Maximum frequency offset in ASK mode	Maximum frequency difference of f_{RF} between Receiver and transmitter in ASK mode $P_{RF_IN} \leq +10\text{dBm}$ $P_{RF_IN} \leq P_{RF_IN_High}$						kHz	B
				$\Delta f_{\text{OFFSET1}}$	-79		+79		
				$\Delta f_{\text{OFFSET2}}$	-85		+85		

*) Type means: A = 100% tested, B = 100% correlation tested, C = Characterized on samples, D = Design parameter

Note: 1. Pin numbers in brackets mean they were measured with RF_IN matched to 50Ω according to [Figure 5-1 on page 10](#) with component values according to [Table 5-2 on page 10](#) (RF_{IN}) and RF_OUT matched to 50Ω according to [Figure 5-12 on page 20](#) with component values according to [Table 5-7 on page 20](#) (RF_{OUT}).

14. Electrical Characteristics: General (Continued)

All parameters refer to GND and are valid for $T_{amb} = -40^{\circ}\text{C}$ to $+105^{\circ}\text{C}$, $V_{VS1} = V_{VS2} = V_{VSINT} = 2.15\text{V}$ to 3.6V (battery application), and $V_{VS2} = 4.4\text{V}$ to 5.6V , $V_{VSINT} = 4.4\text{V}$ to 5.25V (car application). Typical values are given at $V_{VS1} = V_{VS2} = V_{VSINT} = 3\text{V}$ and $T_{amb} = 25^{\circ}\text{C}$, $f_{RF} = 433.92\text{MHz}$ (battery application) unless otherwise specified. Details about current consumption, timing and digital pin properties can be found in the specific sections of the “Electrical Characteristics”.

No.	Parameters	Test Conditions	Pin ⁽¹⁾	Symbol	Min.	Typ.	Max.	Unit	Type*
2.23	Blocking	According to ETSI regulations, the sensitivity ($\text{BER} = 10^{-3}$) is reduced by 3 dB if a continuous wave blocking signal at $\pm\Delta f$ is ΔP_{Block} higher than the useful signal level (Bit rate = 20Kbit/s, FSK, $f_{\text{DEV}} \pm 19.5\text{kHz}$, Manchester code)							
		$f_{\text{RF}} = 315\text{MHz}$ $\Delta f \pm 0.75\text{MHz}$ $\Delta f \pm 1.0\text{MHz}$ $\Delta f \pm 1.5\text{MHz}$ $\Delta f \pm 5.0\text{MHz}$ $\Delta f \pm 10.0\text{MHz}$ Blocking behavior see Figure 5-3 to Figure 5-5 on page 13	(4)	ΔP_{BLOCK}		55 57 60 66 73		dBC	C
		$f_{\text{RF}} = 433.92\text{MHz}$ $\Delta f \pm 0.75\text{MHz}$ $\Delta f \pm 1.0\text{MHz}$ $\Delta f \pm 1.5\text{MHz}$ $\Delta f \pm 5.0\text{MHz}$ $\Delta f \pm 10.0\text{MHz}$ Blocking behavior see Figure 5-3 to Figure 5-5 on page 13	(4)	ΔP_{BLOCK}		54 56 59 65 67		dBC	C
2.24	CDEM	capacitor connected to pin 37 (CDEM)	37		-5%	15	+5%	nF	D
3 Power Amplifier/TX Mode									
3.1	Supply current TX mode power amplifier OFF	$f_{\text{RF}} = 433.92\text{MHz}$ and $f_{\text{RF}} = 315\text{MHz}$	17, 18, 27	$I_{\text{S_TX_PAOFF}}$		6.95		mA	A

*) Type means: A = 100% tested, B = 100% correlation tested, C = Characterized on samples, D = Design parameter

Note: 1. Pin numbers in brackets mean they were measured with RF_IN matched to 50Ω according to [Figure 5-1](#) on page 10 with component values according to [Table 5-2](#) on page 10 (RF_IN) and RF_OUT matched to 50Ω according to [Figure 5-12](#) on page 20 with component values according to [Table 5-7](#) on page 20 (RF_OUT).

14. Electrical Characteristics: General (Continued)

All parameters refer to GND and are valid for $T_{amb} = -40^{\circ}\text{C}$ to $+105^{\circ}\text{C}$, $V_{VS1} = V_{VS2} = V_{VSINT} = 2.15\text{V}$ to 3.6V (battery application), and $V_{VS2} = 4.4\text{V}$ to 5.6V , $V_{VSINT} = 4.4\text{V}$ to 5.25V (car application). Typical values are given at $V_{VS1} = V_{VS2} = V_{VSINT} = 3\text{V}$ and $T_{amb} = 25^{\circ}\text{C}$, $f_{RF} = 433.92\text{MHz}$ (battery application) unless otherwise specified. Details about current consumption, timing and digital pin properties can be found in the specific sections of the “Electrical Characteristics”.

No.	Parameters	Test Conditions	Pin ⁽¹⁾	Symbol	Min.	Typ.	Max.	Unit	Type*
3.2	Output power 1	$V_{VS1} = V_{VS2} = 3\text{V}$ $T_{amb} = 25^{\circ}\text{C}$ $V_{PWR_H} = \text{GND}$ $f_{RF} = 315\text{MHz}$ $R_{R_PWR} = 56\text{k}\Omega$ $R_{Lopt} = 2.5\text{k}\Omega$ $f_{RF} = 433.92\text{MHz}$ $R_{R_PWR} = 56\text{k}\Omega$ $R_{Lopt} = 2.3\text{k}\Omega$ RF_OUT matched to $R_{Lopt} // j/(2 \times \pi \times f_{RF} \times 1.0\text{pF})$	(10)	P_{REF1}	-2.5	0	+2.5	dBm	B
3.3	Supply current TX mode power amplifier ON 1	PA on/0dBm	17, 18, 27	$I_{S_TX_PAON1}$		8.5		mA	B
	0dBm	$f_{RF} = 433.92\text{MHz}$	17, 18, 27	$I_{S_TX_PAON1}$		8.6		mA	B
3.4	Output power 2	$V_{VS1} = V_{VS2} = 3\text{V}$ $T_{amb} = 25^{\circ}\text{C}$ $V_{PWR_H} = \text{GND}$ $f_{RF} = 315\text{MHz}$ $R_{R_PWR} = 30\text{k}\Omega$ $R_{Lopt} = 1.0\text{k}\Omega$ $f_{RF} = 433.92\text{MHz}$ $R_{R_PWR} = 27\text{k}\Omega$ $R_{Lopt} = 1.1\text{k}\Omega$ RF_OUT matched to $R_{Lopt} // j/(2 \times \pi \times f_{RF} \times 1.0\text{pF})$	(10)	P_{REF2}	3.5	5.0	6.5	dBm	B
3.5	Supply current TX mode power amplifier ON 2	PA on/5dBm	17, 18, 27	$I_{S_TX_PAON2}$		10.3		mA	B
	5dBm	$f_{RF} = 433.92\text{MHz}$	17, 18, 27	$I_{S_TX_PAON2}$		10.5		mA	B

*) Type means: A = 100% tested, B = 100% correlation tested, C = Characterized on samples, D = Design parameter

Note: 1. Pin numbers in brackets mean they were measured with RF_IN matched to 50Ω according to [Figure 5-1 on page 10](#) with component values according to [Table 5-2 on page 10](#) (RF_IN) and RF_OUT matched to 50Ω according to [Figure 5-12 on page 20](#) with component values according to [Table 5-7 on page 20](#) (RF_OUT).

14. Electrical Characteristics: General (Continued)

All parameters refer to GND and are valid for $T_{amb} = -40^{\circ}\text{C}$ to $+105^{\circ}\text{C}$, $V_{VS1} = V_{VS2} = V_{VSINT} = 2.15\text{V}$ to 3.6V (battery application), and $V_{VS2} = 4.4\text{V}$ to 5.6V , $V_{VSINT} = 4.4\text{V}$ to 5.25V (car application). Typical values are given at $V_{VS1} = V_{VS2} = V_{VSINT} = 3\text{V}$ and $T_{amb} = 25^{\circ}\text{C}$, $f_{RF} = 433.92\text{MHz}$ (battery application) unless otherwise specified. Details about current consumption, timing and digital pin properties can be found in the specific sections of the “Electrical Characteristics”.

No.	Parameters	Test Conditions	Pin ⁽¹⁾	Symbol	Min.	Typ.	Max.	Unit	Type*	
3.6	Output power 3	$V_{VS1} = V_{VS2} = 3\text{V}$ $T_{amb} = 25^{\circ}\text{C}$ $V_{PWR_H} = AVCC$ $f_{RF} = 315\text{MHz}$ $R_{R_PWR} = 30\text{k}\Omega$ $R_{Lopt} = 0.38\text{k}\Omega$ $f_{RF} = 433.92\text{MHz}$ $R_{R_PWR} = 27\text{k}\Omega$ $R_{Lopt} = 0.36\text{k}\Omega$ RF_OUT matched to $R_{Lopt} // j/(2 \times \pi \times f_{RF} \times 1.0\text{pF})$	(10)	P_{REF3}	8.5	10	11.5	dBm	B	
3.7	Supply current TX mode power amplifier ON 3 10dBm	PA on/10dBm $f_{RF} = 315\text{MHz}$	17, 18, 27	$I_{S_TX_PAON3}$		15.7		mA	B	
		$f_{RF} = 433.92\text{MHz}$	17, 18, 27	$I_{S_TX_PAON3}$		15.8		mA	B	
3.8	Output power variation for full temperature and supply voltage range	$T_{amb} = -40^{\circ}\text{C}$ to $+105^{\circ}\text{C}$ $P_{out} = P_{REFX} + \Delta P_{REF}$ $x = 1, 2$ or 3 $V_{VS1} = V_{VS2} = 3.0\text{V}$	(10)	ΔP_{REF}		-0.8	-1.5	dB	B	
		$V_{VS1} = V_{VS2} = 2.7\text{V}$	(10)	ΔP_{REF}			-2.5	dB	B	
		$V_{VS1} = V_{VS2} = 2.4\text{V}$	(10)	ΔP_{REF}				-3.5	dB	C
		$V_{VS1} = V_{VS2} = 2.15\text{V}$	(10)	ΔP_{REF}				-4.5	dB	B
3.9	Impedance RF_OUT in RX mode	$f_{RF} = 315\text{MHz}$	10	$Z_{RF_OUT_RX}$		(36 - j502)		Ω	C	
		$f_{RF} = 433.92\text{MHz}$	10	$Z_{RF_OUT_RX}$		(19 - j366)		Ω	C	
3.10	Noise floor power amplifier	At $\pm 10\text{MHz}$ /at 5dBm $f_{RF} = 433.92\text{MHz}$	(10)	L_{TX10M}		-126		dBc/Hz	C	
		$f_{RF} = 315\text{MHz}$	(10)	L_{TX10M}		-128		dBc/Hz	C	
3.11	ASK modulation rate	This corresponds to 10Kbit/s Manchester coding and 20Kbit/s NRZ coding		f_{Data_ASK}	1		10	kHz	C	

*) Type means: A = 100% tested, B = 100% correlation tested, C = Characterized on samples, D = Design parameter

Note: 1. Pin numbers in brackets mean they were measured with RF_IN matched to 50Ω according to [Figure 5-1 on page 10](#) with component values according to [Table 5-2 on page 10](#) (RF_IN) and RF_OUT matched to 50Ω according to [Figure 5-12 on page 20](#) with component values according to [Table 5-7 on page 20](#) (RF_OUT).

14. Electrical Characteristics: General (Continued)

All parameters refer to GND and are valid for $T_{amb} = -40^{\circ}\text{C}$ to $+105^{\circ}\text{C}$, $V_{VS1} = V_{VS2} = V_{VSINT} = 2.15\text{V}$ to 3.6V (battery application), and $V_{VS2} = 4.4\text{V}$ to 5.6V , $V_{VSINT} = 4.4\text{V}$ to 5.25V (car application). Typical values are given at $V_{VS1} = V_{VS2} = V_{VSINT} = 3\text{V}$ and $T_{amb} = 25^{\circ}\text{C}$, $f_{RF} = 433.92\text{MHz}$ (battery application) unless otherwise specified. Details about current consumption, timing and digital pin properties can be found in the specific sections of the “Electrical Characteristics”.

No.	Parameters	Test Conditions	Pin ⁽¹⁾	Symbol	Min.	Typ.	Max.	Unit	Type*
5 XTO									
5.1	Pulling XTO due to C_{L1} and C_{L2} tolerances	Pulling at nominal temperature and supply voltage f_{XTAL} = resonant frequency of the XTAL $C_0 \geq 1.0\text{pF}$ $R_m \leq 120\Omega$	24, 25						
		$C_m \leq 7.0\text{fF}$ $C_m \leq 14\text{fF}$			Δf_{XTO1}	-50 -100	f_{XTAL}	+50 +100	ppm
5.2	Transconductance XTO at start	At start-up, after start-up the amplitude is regulated to V_{PPXTAL}	24, 25	$g_{m, XTO}$		19		ms	B
5.3	XTO start-up time	$C_0 \leq 2.2\text{pF}$ $C_m < 14\text{fF}$ $R_m \leq 120\Omega$	24, 25	$T_{PWR_ON_IRQ_1}$		300	800	μs	A
5.4	Maximum C_0 of XTAL	Required for stable operation with internal load capacitors	24, 25	C_{0max}			3.8	pF	D
5.5	Internal capacitors	C_{L1} and C_{L2}	24, 25	C_{L1}, C_{L2}	14.8	18 pF	21.2	pF	B
5.6	Pulling of radio frequency f_{RF} due to XTO, C_{L1} and C_{L2} versus temperature and supply changes	$1.0\text{pF} \leq C_0 \leq 2.2\text{pF}$ $C_m \leq 14\text{fF}$ $R_m \leq 120\Omega$ PLL adjusted with FREQ at nominal temperature and supply voltage	4, 10	Δf_{XTO2}	-2		+2	ppm	C
5.7	Amplitude XTAL after start-up	$C_m = 5\text{fF}$, $C_0 = 1.8\text{pF}$ $R_m = 15\Omega$							
		$V(XTAL1, XTAL2)$ peak-to-peak value	24, 25	V_{PPXTAL}		700		mVpp	C
		$V(XTAL1)$ peak-to-peak value	24	V_{PPXTAL}		350		mVpp	C
5.8	Real part of XTO impedance at start-up	$C_0 \leq 2.2\text{pF}$, small signal start impedance, this value is important for crystal oscillator startup	24, 25	Re_{XTO}		-2000	-1500	Ω	B
5.9	Maximum series resistance R_m of XTAL after start-up	$C_0 \leq 2.2\text{pF}$ $C_m \leq 14\text{fF}$	24, 25	R_{m_max}		15	120	Ω	B
5.10	Nominal XTAL load resonant frequency	$f_{RF} = 433.92\text{MHz}$ $f_{RF} = 315\text{MHz}$	24, 25	f_{XTAL}		13.25311 12.73193		MHz MHz	D

*) Type means: A = 100% tested, B = 100% correlation tested, C = Characterized on samples, D = Design parameter

Note: 1. Pin numbers in brackets mean they were measured with RF_IN matched to 50Ω according to [Figure 5-1 on page 10](#) with component values according to [Table 5-2 on page 10](#) (RF_{IN}) and RF_OUT matched to 50Ω according to [Figure 5-12 on page 20](#) with component values according to [Table 5-7 on page 20](#) (RF_{OUT}).

14. Electrical Characteristics: General (Continued)

All parameters refer to GND and are valid for $T_{amb} = -40^{\circ}\text{C}$ to $+105^{\circ}\text{C}$, $V_{VS1} = V_{VS2} = V_{VSINT} = 2.15\text{V}$ to 3.6V (battery application), and $V_{VS2} = 4.4\text{V}$ to 5.6V , $V_{VSINT} = 4.4\text{V}$ to 5.25V (car application). Typical values are given at $V_{VS1} = V_{VS2} = V_{VSINT} = 3\text{V}$ and $T_{amb} = 25^{\circ}\text{C}$, $f_{RF} = 433.92\text{MHz}$ (battery application) unless otherwise specified. Details about current consumption, timing and digital pin properties can be found in the specific sections of the “Electrical Characteristics”.

No.	Parameters	Test Conditions	Pin ⁽¹⁾	Symbol	Min.	Typ.	Max.	Unit	Type*
5.11	External CLK frequency		30	f_{CLK}		$f_{CLK} = \frac{f_{XTO}}{3}$		MHz	D
		$f_{RF} = 433.92\text{MHz}$ CLK division ratio = 3 CLK has nominal 50% duty cycle	30	f_{CLK}		4.418		MHz	D
		$f_{RF} = 315\text{MHz}$ CLK division ratio = 3 CLK has nominal 50% duty cycle	30	f_{CLK}		4.244		MHz	D
5.12	DC voltage after start-up	$V_{DC}(XTAL1, XTAL2)$ XTO running (IDLE mode, RX mode and TX mode)	24, 25	V_{DCXTO}	-150	-30		me	C
6 Programmable Internal Resistor SETPWR									
6.1	SETPWR in TX- and FD mode	SETPWR = $800\Omega + (31 - PWSET) \times 3\text{ k}\Omega$ PWSET = 16 (see Table 9-25 on page 39)	19	SETPWR		45.8		k Ω	B
6.2	Tolerance of SETPWR versus temperature and supply voltage range		19	SETPWRTOL	-20% $\pm 500\Omega$		+20% $\pm 500\Omega$		B
7 Synthesizer									
7.1	Spurious TX mode	At $\pm f_{CLK}$, CLK enabled $f_{RF} = 315\text{MHz}$ $f_{RF} = 433.92\text{MHz}$		SP_{TX}		< -75 < -75		dBC	A A
		At $\pm f_{XTO}$ $f_{RF} = 315\text{MHz}$ $f_{RF} = 433.92\text{MHz}$		SP_{TX}		-73 -70		dBC	A
7.2	Spurious RX mode	At $\pm f_{CLK}$, CLK enabled $f_{RF} = 315\text{MHz}$ $f_{RF} = 433.92\text{MHz}$		SP_{RX}		< -75 < -75		dBC	A A B
		At $\pm f_{XTO}$ $f_{RF} = 315\text{MHz}$ $f_{RF} = 433.92\text{MHz}$		SP_{RX}		-74 -72		dBC	A
7.3	In loop phase noise TX mode	Measured at 20kHz distance to carrier $f_{RF} = 315\text{MHz}$ $f_{RF} = 433.92\text{MHz}$		L_{TX20k}		-83 -78		dBC/Hz	A

*) Type means: A = 100% tested, B = 100% correlation tested, C = Characterized on samples, D = Design parameter

Note: 1. Pin numbers in brackets mean they were measured with RF_IN matched to 50Ω according to Figure 5-1 on page 10 with component values according to Table 5-2 on page 10 (RF_IN) and RF_OUT matched to 50Ω according to Figure 5-12 on page 20 with component values according to Table 5-7 on page 20 (RF_OUT).

14. Electrical Characteristics: General (Continued)

All parameters refer to GND and are valid for $T_{amb} = -40^{\circ}\text{C}$ to $+105^{\circ}\text{C}$, $V_{VS1} = V_{VS2} = V_{VSINT} = 2.15\text{V}$ to 3.6V (battery application), and $V_{VS2} = 4.4\text{V}$ to 5.6V , $V_{VSINT} = 4.4\text{V}$ to 5.25V (car application). Typical values are given at $V_{VS1} = V_{VS2} = V_{VSINT} = 3\text{V}$ and $T_{amb} = 25^{\circ}\text{C}$, $f_{RF} = 433.92\text{MHz}$ (battery application) unless otherwise specified. Details about current consumption, timing and digital pin properties can be found in the specific sections of the “Electrical Characteristics”.

No.	Parameters	Test Conditions	Pin ⁽¹⁾	Symbol	Min.	Typ.	Max.	Unit	Type*
7.4	Phase noise at 1M RX mode	$f_{RF} = 315\text{MHz}$ $f_{RF} = 433.92\text{MHz}$		L_{RX1M}		-121 -120		dBC/Hz	A
7.5	Phase noise at 1M TX mode	$f_{RF} = 315\text{MHz}$ $f_{RF} = 433.92\text{MHz}$		L_{TX1M}		-113 -111		dBC/Hz	A
7.6	Phase noise at 10M RX mode	Noise floor		L_{RX10M}		< -132		dBC/Hz	B
7.7	Loop bandwidth PLL TX mode	Frequency where the absolute value loop gain is equal to 1		f_{Loop_PLL}		70		kHz	B
7.8	Frequency deviation TX mode	$f_{RF} = 315\text{MHz}$ $f_{RF} = 433.92\text{MHz}$		f_{DEV_TX}		± 18.65 ± 19.41		kHz	D
7.9	Frequency resolution	$f_{RF} = 315\text{MHz}$ $f_{RF} = 433.92\text{MHz}$	4, 10	Δf_{Step_PLL}		777.1 808.9		Hz	D
7.10	FSK modulation rate	This corresponds to 20Kbit/s Manchester coding and 40Kbit/s NRZ coding		f_{Data_FSK}	1		20	kHz	B
8 RX/TX Switch									
8.1	Impedance RX mode	RX mode, pin 38 with short connection to GND , $f_{RF} = 0\text{Hz}$ (DC)	39	Z_{Switch_RX}		23000		Ω	A
		$f_{RF} = 315\text{MHz}$	39	Z_{Switch_RX}		(11.3 – j214)		Ω	C
		$f_{RF} = 433.92\text{MHz}$	39	Z_{Switch_RX}		(10.3 – j153)		Ω	C
8.2	Impedance TX mode	TX mode, pin 38 with short connection to GND , $f_{RF} = 0\text{Hz}$ (DC)	39	Z_{Switch_TX}		5		Ω	A
		$f_{RF} = 315\text{MHz}$	39	Z_{Switch_TX}		(4.8 + j3.2)		Ω	C
		$f_{RF} = 433.92\text{MHz}$	39	Z_{Switch_TX}		(4.5 + j4.3)		Ω	C

*) Type means: A = 100% tested, B = 100% correlation tested, C = Characterized on samples, D = Design parameter

Note: 1. Pin numbers in brackets mean they were measured with RF_IN matched to 50Ω according to [Figure 5-1 on page 10](#) with component values according to [Table 5-2 on page 10](#) (RF_IN) and RF_OUT matched to 50Ω according to [Figure 5-12 on page 20](#) with component values according to [Table 5-7 on page 20](#) (RF_OUT).

14. Electrical Characteristics: General (Continued)

All parameters refer to GND and are valid for $T_{amb} = -40^{\circ}\text{C}$ to $+105^{\circ}\text{C}$, $V_{VS1} = V_{VS2} = V_{VSINT} = 2.15\text{V}$ to 3.6V (battery application), and $V_{VS2} = 4.4\text{V}$ to 5.6V , $V_{VSINT} = 4.4\text{V}$ to 5.25V (car application). Typical values are given at $V_{VS1} = V_{VS2} = V_{VSINT} = 3\text{V}$ and $T_{amb} = 25^{\circ}\text{C}$, $f_{RF} = 433.92\text{MHz}$ (battery application) unless otherwise specified. Details about current consumption, timing and digital pin properties can be found in the specific sections of the “Electrical Characteristics”.

No.	Parameters	Test Conditions	Pin ⁽¹⁾	Symbol	Min.	Typ.	Max.	Unit	Type*
9 Microcontroller Interface									
9.1	Voltage range for microcontroller interface		27, 28, 29, 30, 31, 32, 33, 34, 35		2.15		5.25	V	A
9.2	CLK output rise and fall time	$f_{CLK} < 4.5\text{MHz}$ $C_L = 10\text{pF}$ $C_L = \text{Load capacitance on pin CLK}$ $2.15\text{V} \leq V_{VSINT} \leq 5.25\text{V}$ $20\% \text{ to } 80\% V_{VSINT}$	30	t_{rise}		20	30	ns	B
				t_{fall}		20	30	ns	B
9.3	Current consumption of the microcontroller interface	CLK enabled CLK disabled $C_L = \text{Load capacitance on pin CLK}$ (All interface pins, except pin CLK, are in stable conditions and unloaded)	27	I_{VSINT}		$I_{VSINT} = \frac{(C_{CLK} + C_L) \times V_{VSINT} \times f_{XTO}}{3}$			B
						$< 10\mu\text{A}$			
9.4	Internal equivalent capacitance	Used for current calculation	30, 27	C_{CLK}		8		pF	B

*) Type means: A = 100% tested, B = 100% correlation tested, C = Characterized on samples, D = Design parameter

Note: 1. Pin numbers in brackets mean they were measured with RF_IN matched to 50Ω according to [Figure 5-1 on page 10](#) with component values according to [Table 5-2 on page 10](#) (RF_IN) and RF_OUT matched to 50Ω according to [Figure 5-12 on page 20](#) with component values according to [Table 5-7 on page 20](#) (RF_OUT).

16. Electrical Characteristics: Car Application

All parameters refer to GND and are valid for $T_{amb} = -40^{\circ}\text{C}$ to $+105^{\circ}\text{C}$, $V_{VS2} = 4.4\text{V}$ to 5.6V , $V_{VSINT} = 4.4\text{V}$ to 5.25V . Typical values at $V_{VS2} = 5\text{V}$ and $T_{amb} = 25^{\circ}\text{C}$. Application according to [Figure 4-1 on page 8](#). $f_{RF} = 315.0\text{MHz}/433.92\text{MHz}$ unless otherwise specified. Microcontroller interface current I_{VSINT} has to be added.

No.	Parameters	Test Conditions	Pin	Symbol	Min.	Typ.	Max.	Unit	Type*
12	Car Application								
12.1	Supported voltage range	Car application	17	V_{VS2}	4.4		5.6	V	A
12.2	Supply voltage for microcontroller-interface		27	V_{VSINT}	2.15		5.25	V	A
12.3	Supply current OFF mode	$V_{VS2} = V_{VSINT} \leq 5.25\text{V}$ $I_{OFF} = I_{OFF_VS2} + I_{OFF_VSINT}$	17,27	I_{S_OFF}		0.5	6	μA	A
12.4	Current in IDLE mode on pin VS2	$V_{VS2} \leq 5\text{V}$ CLK enabled	17	I_{IDLE_VS2}		430	600	μA	A
					CLK disabled		360	520	μA
12.5	Supply current IDLE mode	CLK enabled	17, 27	I_{S_IDLE}	$I_{S_IDLE} = I_{IDLE_VS2} + I_{VSINT}$				
12.6	Current in RX mode on pin VS2	$V_{VS2} = 5\text{V}$	17	I_{RX_VS2}		10.8	14.5	mA	B
12.7	Supply current RX mode	CLK enabled	17, 27	I_{S_RX}	$I_{S_RX} = I_{RX_VS2} + I_{VSINT}$				
12.8	Current during $T_{Startup_PLL}$ on pin VS2	$V_{VS2} = 5\text{V}$	17	$I_{Startup_PLL_VS2}$		9.1	12	mA	C
12.9	Current in RX Polling mode on pin VS2	$I_{Poll} = \frac{I_{IDLE_VS2} \times T_{Sleep} + I_{Startup_PLL_VS2} \times T_{Startup_PLL} + I_{RX_VS2} \times (T_{Startup_Sig_Proc} + T_{Bit\ check})}{T_{Sleep} + T_{Startup_PLL} + T_{Startup_Sig_Proc} + T_{Bit\ check}}$							
12.10	Supply current RX polling mode		17, 27	I_{S_Poll}	$I_{S_Poll} = I_{Poll} + I_{VSINT}$				
12.11	Current in TX mode on pin VS2	$V_{VS2} = 5\text{V}$ 315MHz/5dBm	17	I_{TX_VS2}		10.7	13.9	mA	B
		315MHz/10dBm				16.2	21.0		
		433.92MHz/5dBm				10.9	14.0		
		433.92MHz/10dBm				16.3	21.0		
12.12	Supply current TX mode		17, 27	I_{S_TX}	$I_{S_TX} = I_{TX_VS2} + I_{VSINT}$				

*) Type means: A = 100% tested, B = 100% correlation tested, C = Characterized on samples, D = Design parameter

17. Digital Timing Characteristics

All parameters refer to GND and are valid for $T_{amb} = -40^{\circ}\text{C}$ to $+105^{\circ}\text{C}$. $V_{VS1} = V_{VS2} = V_{VSINT} = 2.15\text{V}$ to 3.6V (battery application), and $V_{VS2} = V_{VSINT} = 4.4\text{V}$ to 5.25V (car application), typical values at $V_{VS1} = V_{VS2} = V_{VSINT} = 3\text{V}$ and $T_{amb} = 25^{\circ}\text{C}$ unless otherwise specified.

No.	Parameters	Test Conditions	Pin	Symbol	Min.	Typ.	Max.	Unit	Type*
14	Basic Clock Cycle of the Digital Circuitry								
14.1	Basic clock cycle			T_{DCLK}	$16/f_{XTO}$		$16/f_{XTO}$	μs	A
14.2	Extended basic clock cycle	XLIM = 0		T_{XDCLK}	8		8	μs	A
		BR_Range_0 BR_Range_1 BR_Range_2 BR_Range_3			4 2 1		4 2 1		
		XLIM = 1			16		16		
		BR_Range_0 BR_Range_1 BR_Range_2 BR_Range_3			8 4 2		8 4 2	μs	A
					$\times T_{DCLK}$		$\times T_{DCLK}$		
15	RX Mode/RX Polling Mode								
15.1	Sleep time	Sleep and XSleep are defined in control register 4		T_{Sleep}	$Sleep \times X_{Sleep} \times 1024 \times T_{DCLK}$		$Sleep \times X_{Sleep} \times 1024 \times T_{DCLK}$	ms	A
15.2	Start-up PLL RX mode	From IDLE mode		$T_{Startup_PLL}$		$798.5 \times T_{DCLK}$	$798.5 \times T_{DCLK}$	μs	A
15.3	Start-up signal processing	BR_Range_0 BR_Range_1 BR_Range_2 BR_Range_3		$T_{Startup_Sig_Proc}$	930 546 354 258 $\times T_{DCLK}$		930 546 354 258 $\times T_{DCLK}$		A
15.4	Time for Bit-check	Average time during polling. No RF signal applied. $f_{Signal} = 1/(2 \times t_{ee})$ Signal data rate Manchester (Lim_min and Lim_max up to $\pm 50\%$ of t_{ee} , see Figure 11-3 on page 50) Bit-check time for a valid input signal f_{Signal} $N_{Bit-check} = 0$ $N_{Bit-check} = 3$ $N_{Bit-check} = 6$ $N_{Bit-check} = 9$		T_{Bit_check}	$3/f_{Signal}$ $6/f_{Signal}$ $9/f_{Signal}$	$1/f_{Signal}$	$3.5/f_{Signal}$ $6.5/f_{Signal}$ $9.5/f_{Signal}$	ms	C

*) Type means: A = 100% tested, B = 100% correlation tested, C = Characterized on samples, D = Design parameter

17. Digital Timing Characteristics (Continued)

All parameters refer to GND and are valid for $T_{amb} = -40^{\circ}\text{C}$ to $+105^{\circ}\text{C}$. $V_{VS1} = V_{VS2} = V_{VSINT} = 2.15\text{V}$ to 3.6V (battery application), and $V_{VS2} = V_{VSINT} = 4.4\text{V}$ to 5.25V (car application), typical values at $V_{VS1} = V_{VS2} = V_{VSINT} = 3\text{V}$ and $T_{amb} = 25^{\circ}\text{C}$ unless otherwise specified.

No.	Parameters	Test Conditions	Pin	Symbol	Min.	Typ.	Max.	Unit	Type*
15.5	Bit-rate range	BR_Range = BR_Range0 BR_Range1 BR_Range2 BR_Range3		BR_Range	1.0 2.0 4.0 8.0		2.5 5.0 10.0 20.0	Kbit/s	A
15.6	Minimum time period between edges at pin SDO_TMDO in RX transparent mode	XLIM = 0 BR_Range_0 BR_Range_1 BR_Range_2 BR_Range_3 XLIM = 1 BR_Range_0 BR_Range_1 BR_Range_2 BR_Range_3	31	T_{DATA_min}	$10 \times T_{XDCLK}$			μs	A
15.7	Edge-to-edge time period of the data signal for full sensitivity in RX mode	BR_Range_0 BR_Range_1 BR_Range_2 BR_Range_3		T_{DATA}	200 100 50 25		500 250 125 62.5	μs	B
16	TX Mode								
16.1	Start-up time	From IDLE mode		$T_{Startup}$		$331.5 \times T_{DCLK}$	$331.5 \times T_{DCLK}$	μs	A
17	Configuration of the Transceiver with 4-wire Serial Interface								
17.1	CS set-up time to rising edge of SCK		33, 35	T_{CS_setup}	$1.5 \times T_{DCLK}$			μs	A
17.2	SCK cycle time		33	T_{Cycle}	2			μs	A
17.3	SDI_TMDI set-up time to rising edge of SCK		32, 33	T_{Setup}	250			ns	C
17.4	SDI_TMDI hold time from rising edge of SCK		32, 33	T_{Hold}	250			ns	C
17.5	SDO_TMDO enable time from rising edge of CS		31, 35	T_{Out_enable}			250	ns	C
17.6	SDO_TMDO output delay from falling edge of SCK	$C_L = 10\text{pF}$	31, 35	T_{Out_delay}			250	ns	C
17.7	SDO_TMDO disable time from falling edge of CS		31, 33	$T_{Out_disable}$			250	ns	C
17.8	CS disable time period		35	$T_{CS_disable}$	$1.5 \times T_{DCLK}$			μs	A

*) Type means: A = 100% tested, B = 100% correlation tested, C = Characterized on samples, D = Design parameter

17. Digital Timing Characteristics (Continued)

All parameters refer to GND and are valid for $T_{amb} = -40^{\circ}\text{C}$ to $+105^{\circ}\text{C}$. $V_{VS1} = V_{VS2} = V_{VSINT} = 2.15\text{V}$ to 3.6V (battery application), and $V_{VS2} = V_{VSINT} = 4.4\text{V}$ to 5.25V (car application), typical values at $V_{VS1} = V_{VS2} = V_{VSINT} = 3\text{V}$ and $T_{amb} = 25^{\circ}\text{C}$ unless otherwise specified.

No.	Parameters	Test Conditions	Pin	Symbol	Min.	Typ.	Max.	Unit	Type*
17.9	Time period SCK low to CS high		33, 35	T_{SCK_setup1}	250			ns	C
17.10	Time period SCK low to CS low		33, 35	T_{SCK_setup2}	250			ns	C
17.11	Time period CS low to SCK high		33, 35	T_{SCK_hold}	250			ns	C
18	Start Time Push Button N_PWR_ON and PWR_ON Timing of wake-up via PWR_ON or N_PWR_ON								
18.1	PWR_ON high to positive edge on pin IRQ (Figure 9-4 on page 42)	From OFF mode to IDLE mode, applications according to Figure 3-1 on page 7, Figure 4-1 on page 8 XTAL: $C_m < 14\text{fF}$ (typ. 5fF) $C_0 < 2.2\text{pF}$ (typ. 1.8pF) $R_m \leq 120\Omega$ (typ. 15 Ω) battery application $C_1 = C_2 = C_3 = 68\text{nF}$ $C_5 = C_7 = 10\text{nF}$ car application $C_1 = C_3 = C_4 = 68\text{nF}$ $C_2 = 2.2\mu\text{F}$ $C_5 = 10\text{nF}$	29, 40	$T_{PWR_ON_IRQ_1}$		0.3 0.45	0.8 1.3	ms	B

*) Type means: A = 100% tested, B = 100% correlation tested, C = Characterized on samples, D = Design parameter

17. Digital Timing Characteristics (Continued)

All parameters refer to GND and are valid for $T_{amb} = -40^{\circ}\text{C}$ to $+105^{\circ}\text{C}$. $V_{VS1} = V_{VS2} = V_{VSINT} = 2.15\text{V}$ to 3.6V (battery application), and $V_{VS2} = V_{VSINT} = 4.4\text{V}$ to 5.25V (car application), typical values at $V_{VS1} = V_{VS2} = V_{VSINT} = 3\text{V}$ and $T_{amb} = 25^{\circ}\text{C}$ unless otherwise specified.

No.	Parameters	Test Conditions	Pin	Symbol	Min.	Typ.	Max.	Unit	Type*
18.2	PWR_ON high to positive edge on pin IRQ (Figure 9-4 on page 42)	From every mode except OFF mode	29, 40	$T_{\text{PWR_ON_IRQ_2}}$			$2 \times T_{\text{DCLK}}$	μs	A
18.3	N_PWR_ON low to positive edge on pin IRQ (Figure 9-2 on page 40)	From OFF mode to IDLE mode, applications according to Figure 3-1 on page 7, Figure 4-1 on page 8 XTAL: $C_m < 14\text{fF}$ (typ 5fF) $C_0 < 2.2\text{pF}$ (typ 1.8pF) $R_m \leq 120\Omega$ (typ 15 Ω) battery application $C_1 = C_2 = 68\text{nF}$ $C_3 = C_4 = 68\text{nF}$ $C_5 = 10\text{nF}$ car application $C_1 = C_4 = 68\text{nF}$ $C_2 = C_3 = 2.2\mu\text{F}$ $C_5 = 10\text{nF}$	29, 45	$T_{\text{N_PWR_ON_IRQ}}$		0.3 0.45	0.8 1.3	ms	B
18.4	Push button debounce time	Every mode except OFF mode	29, 45	T_{Debounce}	$8195 \times T_{\text{DCLK}}$		$8195 \times T_{\text{DCLK}}$	μs	A

*) Type means: A = 100% tested, B = 100% correlation tested, C = Characterized on samples, D = Design parameter

18. Digital Port Characteristics

All parameter refer to GND and valid for $T_{amb} = -40^{\circ}\text{C}$ to $+105^{\circ}\text{C}$, $V_{VS1} = V_{VS2} = 2.15\text{V}$ to 3.6V (battery application) and $V_{VS2} = 4.4\text{V}$ to 5.25V (car application) typical values at $V_{VS1} = V_{VS2} = 3\text{V}$ (battery application) and $T_{amb} = 25^{\circ}\text{C}$ unless otherwise specified.

$V_{VSINT} = 2.15\text{V}$ to 5.25V can be used independent from V_{VS1} and V_{VS2} in the case the microcontroller uses an different supply voltage.

No.	Parameters	Test Conditions	Pin	Symbol	Min.	Typ.	Max.	Unit	Type*
20	Digital Ports								
20.1	CS input - low level input voltage	$V_{VSINT} = 2.15\text{V}$ to 5.25V	35	V_{ll}			$0.2 \times V_{VSINT}$	V	A
	- high level input voltage	$V_{VSINT} = 2.15\text{V}$ to 5.25V	35	V_{lh}	$0.8 \times V_{VSINT}$			V	A
20.2	SCK input - low level input voltage	$V_{VSINT} = 2.15\text{V}$ to 5.25V	33	V_{ll}			$0.2 \times V_{VSINT}$	V	A
	- high level input voltage	$V_{VSINT} = 2.15\text{V}$ to 5.25V	33	V_{lh}	$0.8 \times V_{VSINT}$			V	A
20.3	SDI_TMDI input - low level input voltage	$V_{VSINT} = 2.15\text{V}$ to 5.25V	32	V_{ll}			$0.2 \times V_{VSINT}$	V	A
	- high level input voltage	$V_{VSINT} = 2.15\text{V}$ to 5.25V	32	V_{lh}	$0.8 \times V_{VSINT}$			V	A
20.4	TEST1 input	TEST1 input must always be directly connected to GND	20		0		0	V	
20.5	TEST2 input	TEST2 input must always be direct connected to GND	23		0		0	V	
20.6	PWR_ON input - low level input voltage	$V_{VSINT} = 2.15\text{V}$ to 5.25V	40	V_{ll}			$0.2 \times V_{VSINT}$	V	A
	- high level input voltage	$V_{VSINT} = 2.15\text{V}$ to 5.25V	40	V_{lh}	$0.8 \times V_{VSINT}$			V	A
20.7	N_PWR_ON input - low level input voltage	$V_{VSINT} = 2.15\text{V}$ to 5.25V Internal pull-up resistor of $50\text{k}\Omega \pm 20\%$	45	V_{ll}			$0.2 \times V_{VSINT}$	V	A
	- high level input voltage	$V_{VSINT} = 2.15\text{V}$ to 5.25V Internal pull-up resistor of $50\text{k}\Omega \pm 20\%$	45	V_{lh}	$0.8 \times V_{VSINT}$			V	A
20.8	CS_POL input -low level input voltage		22	V_{ll}			$0.2 \times V_{DVCC}$	V	A
	- high level input voltage		22	V_{lh}	$0.8 \times V_{DVCC}$		V_{DVCC}	V	A
20.9	SCK_POL input - low level input voltage		43	V_{ll}			$0.2 \times V_{DVCC}$	V	A
	- high level input voltage		43	V_{lh}	$0.8 \times V_{DVCC}$		V_{DVCC}	V	A
20.10	SCK_PHA input - low level input voltage		44	V_{ll}			$0.2 \times V_{DVCC}$	V	A
	- high level input voltage		44	V_{lh}	$0.8 \times V_{DVCC}$		V_{DVCC}	V	A

*) Type means: A = 100% tested, B = 100% correlation tested, C = Characterized on samples, D = Design parameter

18. Digital Port Characteristics (Continued)

All parameter refer to GND and valid for $T_{amb} = -40^{\circ}\text{C}$ to $+105^{\circ}\text{C}$, $V_{VS1} = V_{VS2} = 2.15\text{V}$ to 3.6V (battery application) and $V_{VS2} = 4.4\text{V}$ to 5.25V (car application) typical values at $V_{VS1} = V_{VS2} = 3\text{V}$ (battery application) and $T_{amb} = 25^{\circ}\text{C}$ unless otherwise specified.
 $V_{VSINT} = 2.15\text{V}$ to 5.25V can be used independent from V_{VS1} and V_{VS2} in the case the microcontroller uses an different supply voltage.

No.	Parameters	Test Conditions	Pin	Symbol	Min.	Typ.	Max.	Unit	Type*
20.11	433_N868 input - low level input voltage		6	V_{ll}			0.25	V	A
	- high level input voltage		6	V_{lh}	1.7		AVCC	V	A
20.12	PWR_H input - low level input voltage		9	V_{ll}			0.25	V	A
	- high level input voltage		9	V_{lh}	1.7		AVCC	V	A
20.13	SDO_TMDO output - saturation voltage low	$V_{VSINT} = 2.15\text{V}$ to 5.25V $I_{SDO_TMDO} = 250\mu\text{A}$	31	V_{ol}		0.15	0.4	V	B
	- saturation voltage high	$V_{VSINT} = 2.15\text{V}$ to 5.25V $I_{SDO_TMDO} = -250\mu\text{A}$	31	V_{oh}	$V_{VSINT} - 0.4$	$V_{VSINT} - 0.15$		V	B
20.14	IRQ output - saturation voltage low	$V_{VSINT} = 2.15\text{V}$ to 5.25V $I_{IRQ} = 250\mu\text{A}$	29	V_{ol}		0.15	0.4	V	B
	- saturation voltage high	$V_{VSINT} = 2.15\text{V}$ to 5.25V $I_{IRQ} = -250\mu\text{A}$	29	V_{oh}	$V_{VSINT} - 0.4$	$V_{VSINT} - 0.15$		V	B
20.15	CLK output - saturation voltage low	$V_{VSINT} = 2.15\text{V}$ to 5.25V $I_{CLK} = 100\mu\text{A}$ internal series resistor of $1\text{k}\Omega$ for spurious reduction in PLL	30	V_{ol}		0.15	0.4	V	B
	- saturation voltage high	$V_{VSINT} = 2.15\text{V}$ to 5.25V $I_{CLK} = -100\mu\text{A}$ internal series resistor of $1\text{k}\Omega$ for spurious reduction in PLL	30	V_{oh}	$V_{VSINT} - 0.4$	$V_{VSINT} - 0.15$		V	B
20.16	POUT output - saturation voltage low	$V_{VSINT} = 2.15\text{V}$ to 5.25V $I_{POUT} = 250\mu\text{A}$	28	V_{ol}		0.15	0.4	V	B
	POUT output - saturation voltage low	$V_{VSINT} = 5\text{V}$ $I_{POUT} = 1000\mu\text{A}$	28	V_{ol}		0.4	0.6	V	B
	POUT output - saturation voltage high	$V_{VSINT} = 2.15\text{V}$ to 5.25V $I_{POUT} = -1500\mu\text{A}$	28	V_{oh}	$V_{VSINT} - 0.4$	$V_{VSINT} - 0.15$		V	B
20.17	RX_ACTIVE output - saturation voltage low	$I_{RX_ACTIVE} = 25\mu\text{A}$	46	V_{ol}		0.25	0.4	V	B
	RX_ACTIVE output - saturation voltage high	$I_{RX_ACTIVE} = -1500\mu\text{A}$	46	V_{oh}	$V_{AVCC} - 0.5$	$V_{AVCC} - 0.15$		V	B
20.18	TEST3 output	TEST3 output must always be directly connected to GND	34		0		0	V	

*) Type means: A = 100% tested, B = 100% correlation tested, C = Characterized on samples, D = Design parameter

19. Ordering Information

Extended Type Number	Package	Remarks
ATA5823C-PLQW-1	QFN48	7mm x 7mm, Pb-free, 4k
ATA5824C-PLQW-1	QFN48	7mm x 7mm, Pb-free, 4k

20. Package Information

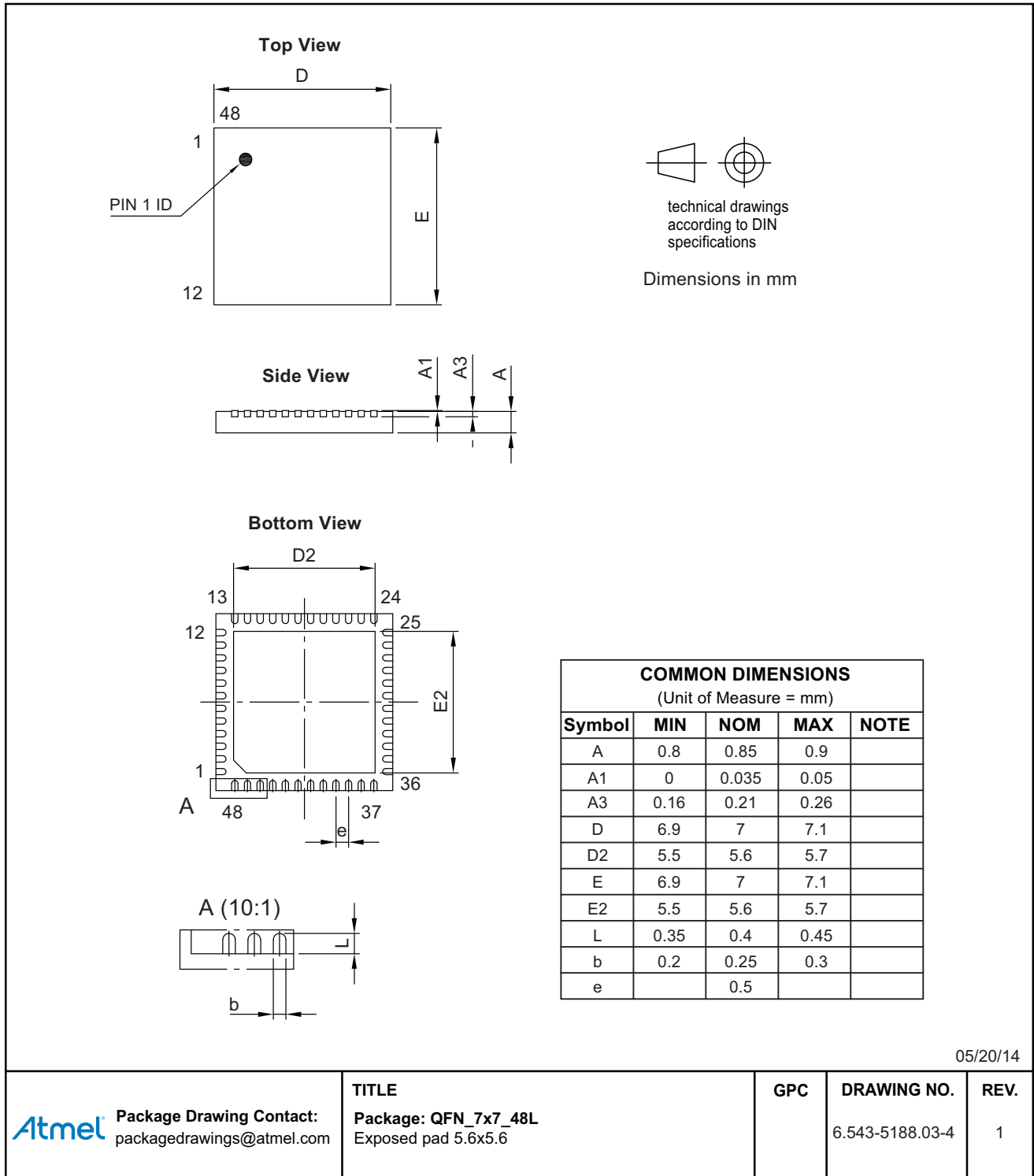

21. Revision History

Please note that the following page numbers referred to in this section refer to the specific revision mentioned, not to this document.

Revision No.	History
4829G-RKE-01/15	<ul style="list-style-type: none">• Section 19 “Ordering Information” on page 80 updated• Section 20 “Package Information” on page 80 updated
4829F-RKE-05/14	<ul style="list-style-type: none">• Removal of the 868MHz option and the full-duplex operation mode
4829E-RKE-07/13	<ul style="list-style-type: none">• Section 22 “Ordering Information” on page 93 updated
4829D-RKE-06/06	<ul style="list-style-type: none">• Put datasheet in a new template• kBaud replaced through Kbit/s• Baud replaced through bit• Table 14-8 “Interrupt Handling” on page 70 changed



Atmel Corporation 1600 Technology Drive, San Jose, CA 95110 USA T: (+1)(408) 441.0311 F: (+1)(408) 436.4200 | www.atmel.com

© 2015 Atmel Corporation. / Rev.: 4829G–RKE–01/15

Atmel®, Atmel logo and combinations thereof, Enabling Unlimited Possibilities®, and others are registered trademarks or trademarks of Atmel Corporation in U.S. and other countries. Other terms and product names may be trademarks of others.

DISCLAIMER: The information in this document is provided in connection with Atmel products. No license, express or implied, by estoppel or otherwise, to any intellectual property right is granted by this document or in connection with the sale of Atmel products. EXCEPT AS SET FORTH IN THE ATMEL TERMS AND CONDITIONS OF SALES LOCATED ON THE ATMEL WEBSITE, ATMEL ASSUMES NO LIABILITY WHATSOEVER AND DISCLAIMS ANY EXPRESS, IMPLIED OR STATUTORY WARRANTY RELATING TO ITS PRODUCTS INCLUDING, BUT NOT LIMITED TO, THE IMPLIED WARRANTY OF MERCHANTABILITY, FITNESS FOR A PARTICULAR PURPOSE, OR NON-INFRINGEMENT. IN NO EVENT SHALL ATMEL BE LIABLE FOR ANY DIRECT, INDIRECT, CONSEQUENTIAL, PUNITIVE, SPECIAL OR INCIDENTAL DAMAGES (INCLUDING, WITHOUT LIMITATION, DAMAGES FOR LOSS AND PROFITS, BUSINESS INTERRUPTION, OR LOSS OF INFORMATION) ARISING OUT OF THE USE OR INABILITY TO USE THIS DOCUMENT, EVEN IF ATMEL HAS BEEN ADVISED OF THE POSSIBILITY OF SUCH DAMAGES. Atmel makes no representations or warranties with respect to the accuracy or completeness of the contents of this document and reserves the right to make changes to specifications and products descriptions at any time without notice. Atmel does not make any commitment to update the information contained herein. Unless specifically provided otherwise, Atmel products are not suitable for, and shall not be used in, automotive applications. Atmel products are not intended, authorized, or warranted for use as components in applications intended to support or sustain life.

SAFETY-CRITICAL, MILITARY, AND AUTOMOTIVE APPLICATIONS DISCLAIMER: Atmel products are not designed for and will not be used in connection with any applications where the failure of such products would reasonably be expected to result in significant personal injury or death ("Safety-Critical Applications") without an Atmel officer's specific written consent. Safety-Critical Applications include, without limitation, life support devices and systems, equipment or systems for the operation of nuclear facilities and weapons systems. Atmel products are not designed nor intended for use in military or aerospace applications or environments unless specifically designated by Atmel as military-grade. Atmel products are not designed nor intended for use in automotive applications unless specifically designated by Atmel as automotive-grade.

Mouser Electronics

Authorized Distributor

Click to View Pricing, Inventory, Delivery & Lifecycle Information:

[Microchip:](#)

[ATA5824C-PLQW](#) [ATA5823C-PLQW](#)

Компания «Океан Электроники» предлагает заключение долгосрочных отношений при поставках импортных электронных компонентов на взаимовыгодных условиях!

Наши преимущества:

- Поставка оригинальных импортных электронных компонентов напрямую с производств Америки, Европы и Азии, а так же с крупнейших складов мира;
- Широкая линейка поставок активных и пассивных импортных электронных компонентов (более 30 млн. наименований);
- Поставка сложных, дефицитных, либо снятых с производства позиций;
- Оперативные сроки поставки под заказ (от 5 рабочих дней);
- Экспресс доставка в любую точку России;
- Помощь Конструкторского Отдела и консультации квалифицированных инженеров;
- Техническая поддержка проекта, помощь в подборе аналогов, поставка прототипов;
- Поставка электронных компонентов под контролем ВП;
- Система менеджмента качества сертифицирована по Международному стандарту ISO 9001;
- При необходимости вся продукция военного и аэрокосмического назначения проходит испытания и сертификацию в лаборатории (по согласованию с заказчиком);
- Поставка специализированных компонентов военного и аэрокосмического уровня качества (Xilinx, Altera, Analog Devices, Intersil, Interpoint, Microsemi, Actel, Aeroflex, Peregrine, VPT, Syfer, Eurofarad, Texas Instruments, MS Kennedy, Miteq, Cobham, E2V, MA-COM, Hittite, Mini-Circuits, General Dynamics и др.);

Компания «Океан Электроники» является официальным дистрибьютором и эксклюзивным представителем в России одного из крупнейших производителей разъемов военного и аэрокосмического назначения «JONHON», а так же официальным дистрибьютором и эксклюзивным представителем в России производителя высокотехнологичных и надежных решений для передачи СВЧ сигналов «FORSTAR».



JONHON

«JONHON» (основан в 1970 г.)

Разъемы специального, военного и аэрокосмического назначения:

(Применяются в военной, авиационной, аэрокосмической, морской, железнодорожной, горно- и нефтедобывающей отраслях промышленности)

«FORSTAR» (основан в 1998 г.)

ВЧ соединители, коаксиальные кабели, кабельные сборки и микроволновые компоненты:

(Применяются в телекоммуникациях гражданского и специального назначения, в средствах связи, РЛС, а так же военной, авиационной и аэрокосмической отраслях промышленности).



Телефон: 8 (812) 309-75-97 (многоканальный)

Факс: 8 (812) 320-03-32

Электронная почта: ocean@oceanchips.ru

Web: <http://oceanchips.ru/>

Адрес: 198099, г. Санкт-Петербург, ул. Калинина, д. 2, корп. 4, лит. А