

# HFBR-0600Z Series

## SERCOS Fiber Optic Transmitters and Receivers

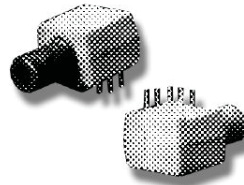

## Data Sheet



### SERCOS

SERCOS is a Serial Realtime Communication System, a standard digital interface for communication between controls and drives for numerically controlled machines. The SERCOS interface specification was written by a joint working group of the VDW (German Machine Tool Builders Association) and ZVEI (German Electrical and Electronic Manufacturer's Association) to allow data exchange between NC controls and drives via fiber optic rings, with isolation and noise immunity. The HFBR-0600Z family of fiber optic transmitters and receivers comply to the SERCOS specifications for transmitter and receiver optical characteristics and connector style (SMA).

### Description

The HFBR-0600Z components are capable of operation at symbol rates from DC to over 2 MBd and distances from 0 to over 20 metres. The HFBR-1602Z and HFBR-1604Z transmitters contain a 655 nm AlGaAs emitter capable of efficiently launching optical power into 1000 mm plastic optical fiber. The optical output is specified at the end of 0.5 m of plastic optical fiber.

The HFBR-1604Z is a selected version of the HFBR-1602, with power specified to meet the SERCOS high attenuation specifications.

The HFBR-2602Z receiver incorporates an integrated photo IC containing a photodetector and DC amplifier driving an open-collector Schottky output transistor. The HFBR-2602Z is designed for direct interfacing to popular logic families. The absence of an internal pullup resistor allows the open-collector output to be used with logic families such as CMOS requiring voltage excursions higher than  $V_{CC}$ . The HFBR-2602Z has a dynamic range of 15 dB.

### Features

- Fully compliant to SERCOS optical specifications
- Optimized for 1 mm plastic optical fiber
- Compatible with SMA connectors
- Auto-insertable and wave solderable
- Data transmission at symbol rates from DC to over 2 MBd for distances from 0 to over 20 metres

### Applications

- Industrial control data links
- Reduction of lightning and voltage transient susceptibility
- Tempest-secure data processing equipment
- Isolation in test and measurement instruments
- Robotics communication

**CAUTION:** The small junction sizes inherent to the design of this component increase the component's susceptibility to damage from electrostatic discharge (ESD). It is advised that normal static precautions be taken in handling and assembly of this component to prevent damage and/or degradation which may be induced by ESD.

## HFBR-160XZ Transmitters

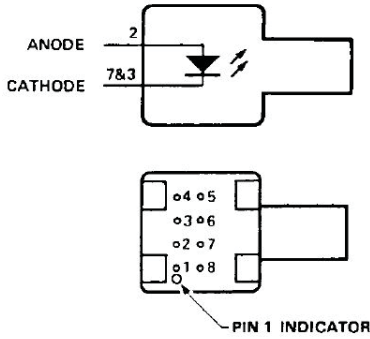

Pin	Function
1*	N.C.
2	ANODE
3	N.C.
4*	N.C.
5*	N.C.
6	N.C.
7**	CATHODE
8*	N.C.

## HFBR-2602Z Receiver

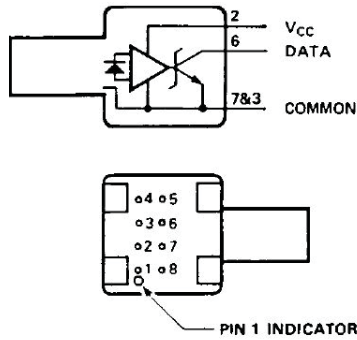

Pin	Function
1*	N.C.
2	V <sub>CC</sub> (5 V)
3	COMMON
4*	N.C.
5*	N.C.
6	DATA
7	COMMON
8*	N.C.

\* Pins 1, 4, 5, and 8 are isolated from the internal circuitry, but electrically connected to one another.

\*\* Transmitter Pin 7 may be left unconnected if necessary.

In the receiver, both the opencollector "Data" output Pin 6 and V<sub>CC</sub> Pin 2 are referenced to "Common" Pin 3 and 7. It is essential that a bypass capacitor (0.1 μF ceramic) be connected from Pin 2 (V<sub>CC</sub>) to Pin 3 (circuit common) of the receiver.

## HFBR-0600Z SMA Series

### Mechanical Dimensions

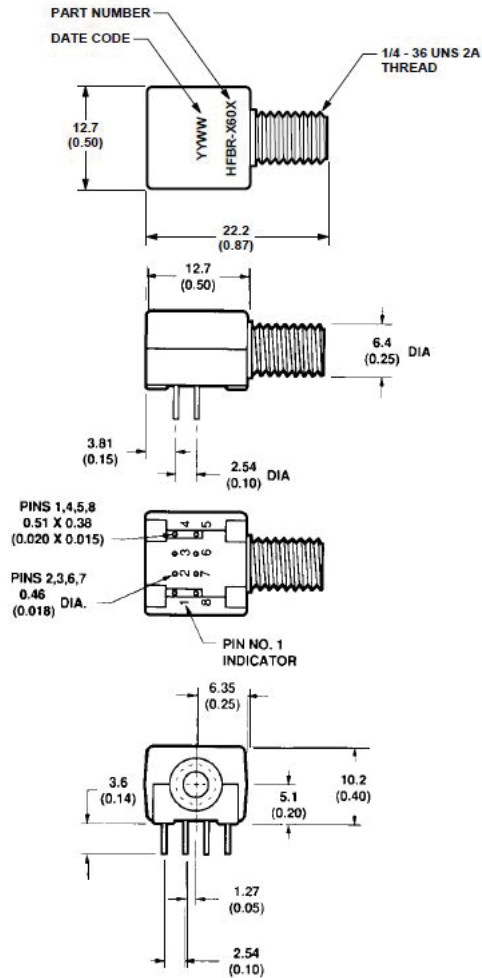

SMA is an industry standard fiber optic connector, available from many fiber optic connector suppliers. HFBR-4401Z is a kit consisting of 100 nuts and 100 washers for panel mounting the HFBR-0600Z components.

## HFBR-1602Z/1604Z Transmitters

### Absolute Maximum Ratings

Parameter	Symbol	Min.	Max.	Units	Reference
Storage Temperature	$T_S$	-55	85	°C	
Operating Temperature	$T_A$	-40	85	°C	
Lead Soldering Cycle	Temp.		260	°C	Note 1
	Time		10	s	Note 1
Forward Input Current Peak	$I_{FPK}$		120	mA	
Forward Input Current Average	$I_{Favg}$		60	mA	
Reverse Input Voltage	$V_{BR}$		-5	V	

### Electrical/Optical Characteristics 0 to 55° C, unless otherwise stated.

Parameter	Symbol	Min.	Typ. <sup>[2]</sup>	Max.	Unit	Condition	Reference
Forward Voltage	$V_F$	1.5	1.9	2.2	V	$I_F = 35$ mA	
Forward Voltage Temp. Coefficient	$\Delta V_F / \Delta T$		-1.2		mV/°C	$I_F = 35$ mA	
Reverse Input Voltage	$V_{BR}$	-5.0	-18		V	$I_R = 100$ $\mu$ A	
Peak Emission Wavelength	$\lambda_P$	640	655	675	nm		
Full Width Half Maximum	FWHM		20	30	nm	25° C	
Diode Capacitance	$C_T$		30		pF	$V_F = 0$ $f = 1$ MHz	
Optical Power Temp. Coefficient	$\Delta P_T / \Delta T$		-0.01		dBm/°C	$I_F = 35$ mA	
Thermal Resistance	$\theta_{JA}$		330		°C/W		Notes 3, 4
Peak Optical Output Power of HFBR-1602Z	$P_{T1602}$	-10.5		-5.5	dBm	$I_F = 35$ mA	Notes 5, 6, 11
Peak Optical Output Power of HFBR-1604Z	$P_{T1604}$	-7.5		-3.5	dBm	$I_F = 60$ mA	Notes 5, 6, 11
		-10.5		-5.5	dBm	$I_F = 35$ mA	
Rise Time (10% to 90%)	$t_r$		57		ns	$I_F = 60$ mA	
			50		ns	$I_F = 35$ mA	
Fall Time (90% to 10%)	$t_f$		40		ns	$I_F = 60$ mA	
			27		ns	$I_F = 35$ mA	

## HFBR-2602Z Receiver

### Absolute Maximum Ratings

Parameter	Symbol	Min.	Max.	Units	Reference
Storage Temperature	T <sub>S</sub>	-55	85	°C	
Operating Temperature	T <sub>A</sub>	-40	85	°C	
Lead Soldering Cycle	Temp.		260	°C	Note 1
	Time		10	s	Note 1
Supply Voltage	V <sub>CC</sub>	-0.5	7.0	V	
Output Current	I <sub>O</sub>		25	mA	
Output Voltage	V <sub>O</sub>	-0.5	18.0	V	
Output Collector Power Dissipation	P <sub>O AVG</sub>		40	mW	
Fan Out (TTL)	N		5		Note 8

### Electrical/Optical Characteristics 0 to 55° C;

Fiber core diameter ≤ 1.0 mm, fiber N.A. ≤ 0.5, 4.75 V ≤ V<sub>CC</sub> ≤ 5.25 V

Parameter	Symbol	Min.	Typ. <sup>[2]</sup>	Max.	Unit	Condition	Reference
High Level Output Current	I <sub>OH</sub>		5	250	μA	V <sub>OH</sub> = 18 V P <sub>R</sub> < -31.2 dBm	
Low Level Output Voltage	V <sub>OL</sub>		0.4	0.5	V	I <sub>OL</sub> = 8 mA P <sub>R</sub> > -20.0 dBm	
High Level Supply Current	I <sub>CCH</sub>		3.5	6.3	mA	V <sub>CC</sub> = 5.25 V P <sub>R</sub> < -31.2 dBm	
Low Level Supply Current	I <sub>CCL</sub>		6.2	10	mA	V <sub>CC</sub> = 5.25 V P <sub>R</sub> > -20.0 dBm	

### Dynamic Characteristics 0 to 55° C unless otherwise specified; 4.75 V ≤ V<sub>CC</sub> ≤ 5.25 V; BER ≤ 10<sup>-9</sup>

Parameter	Symbol	Min.	Typ. <sup>[2]</sup>	Max.	Unit	Condition	Reference
Peak Input Power Level Logic HIGH	P <sub>RH</sub>			-31.2	dBm	λ <sub>p</sub> = 655 nm	Note 7
Peak Input Power Level Logic LOW	P <sub>RL</sub>	-20.0		-5.0	dBm	I <sub>OL</sub> = 8 mA	Note 7
Propagation Delay LOW to HIGH	t <sub>PLH</sub>		60		ns	P <sub>R</sub> = -20 dBm 2 MBd	Note 8, 9
Propagation Delay HIGH to LOW	t <sub>PHL</sub>		110		ns	P <sub>R</sub> = -20 dBm 2 MBd	Note 8, 9
Pulse Width Distortion, t <sub>PLH</sub> - t <sub>PHL</sub>	PWD		50		ns	P <sub>R</sub> = -5 dBm	Note 10
			-50		ns	P <sub>R</sub> = -20 dBm	Figure 6

Notes:

- 2.0 mm from where leads enter case.
- Typical data at T<sub>A</sub> = +25° C.
- Thermal resistance is measured with the transmitter coupled to a connector assembly and fiber, and mounted on a printed circuit board.
- Pins 2, 6, and 7 are welded to the cathode header connection to minimize the thermal resistance from junction to ambient. To further reduce the thermal resistance, the cathode trace should be made as large as is consistent with good RF circuit design.
- P<sub>T</sub> is measured with a large area detector at the end of 0.5 metre of plastic optical fiber with 1 mm diameter and numerical aperture of 0.5.
- When changing μW to dBm, the optical power is referenced to 1 mW (1000 μW). Optical Power P(dBm) = 10 log [P (μW)/1000 μW].
- Measured at the end of 1 mm plastic fiber optic cable with a large area detector.
- 8 mA load (5 x 1.6 mA), R<sub>L</sub> = 560 Ω.
- Propagation delay through the system is the result of several sequentially occurring phenomena. Consequently it is a combination of data-rate-limiting effects and of transmission-time effects. Because of this, the data-rate limit of the system must be described in terms of time differentials between delays imposed on falling and rising edges. As the cable length is increased, the propagation delays increase. Data-rate, as limited by pulse width distortion, is not affected by increasing cable length if the optical power level at the receiver is maintained.
- Pulse width distortion is the difference between the delay of the rising and falling edges.
- Both HFBR-1602Z and HFBR-1604Z meet the SERCOS "low attenuation" specifications when operated at 35 mA; only HFBR-1604Z meets the SERCOS "high attenuation" limits when operated at 60 mA.

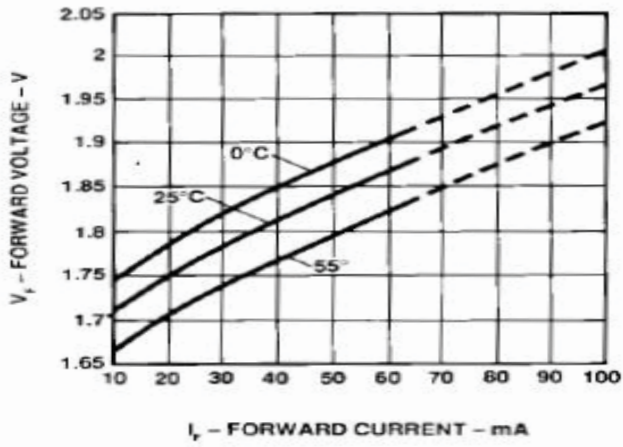

Figure 1. Forward voltage and current characteristics.

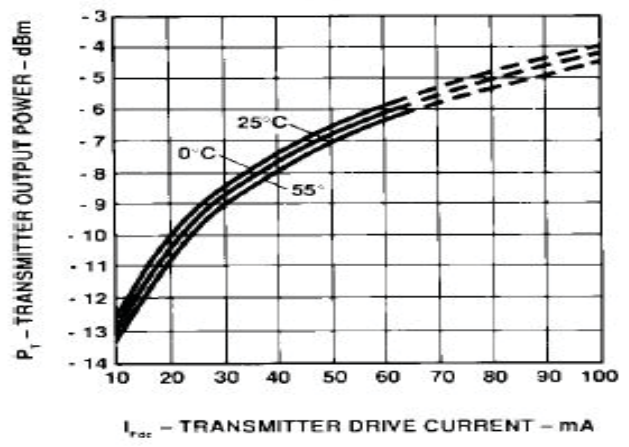

Figure 2. Typical transmitter output vs. forward current.

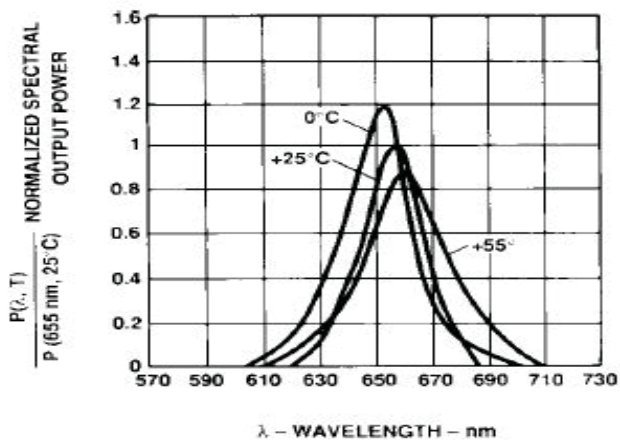

Figure 3. Transmitter spectrum normalized to the peak at 25°C.

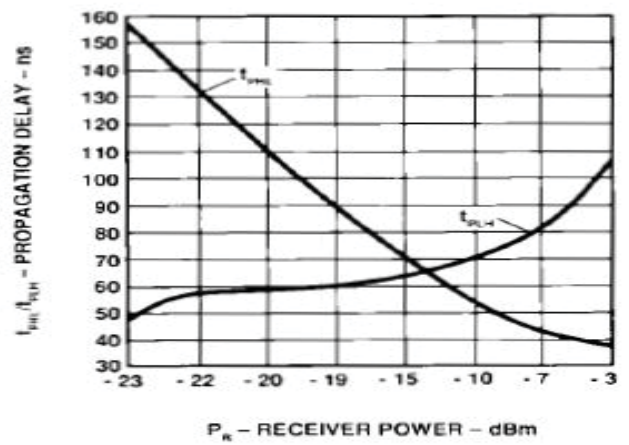

Figure 4. Typical propagation delay through system with 0.5 metre of cable.

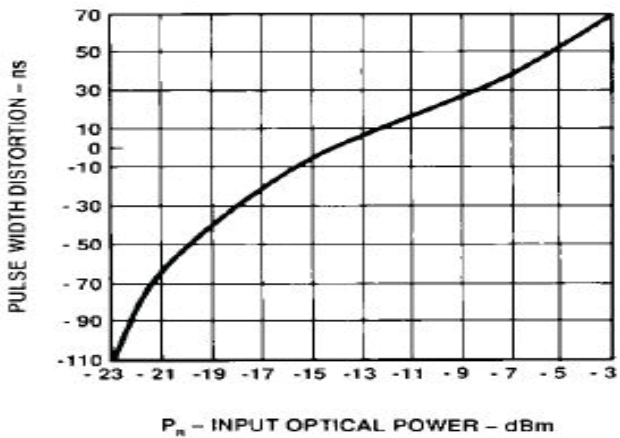

Figure 5. Typical HFBR-160XZ/2602Z link pulsewidth distortion vs. optical power.

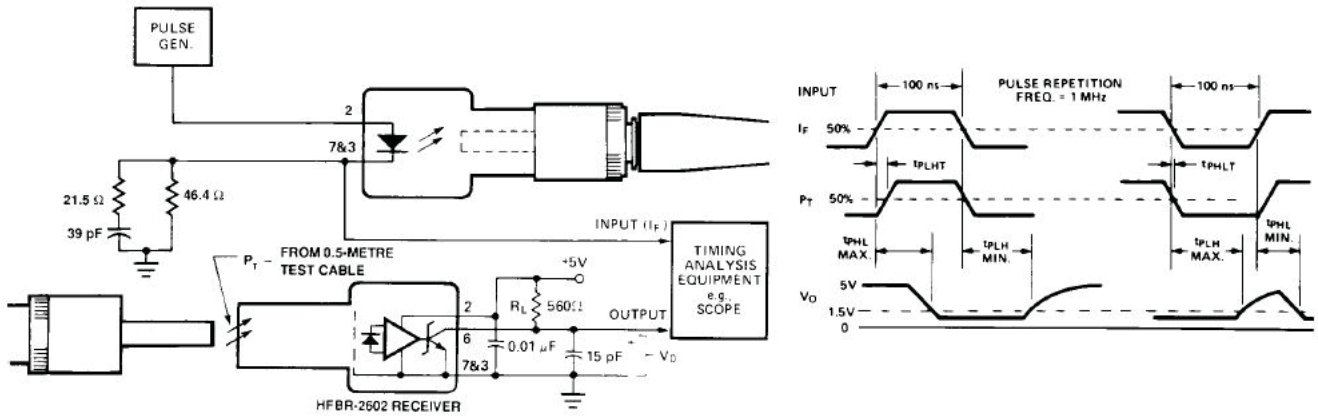

Figure 6. System propagation delay test circuit and waveform timing definitions.

For product information and a complete list of distributors, please go to our web site: [www.avagotech.com](http://www.avagotech.com)

Avago, Avago Technologies, and the A logo are trademarks of Avago Technologies in the United States and other countries. Data subject to change. Copyright © 2005–2012 Avago Technologies. All rights reserved. Obsoletes 5989-4798EN AV02-3638EN - June 19, 2012

**Avago**  
TECHNOLOGIES

Компания «Океан Электроники» предлагает заключение долгосрочных отношений при поставках импортных электронных компонентов на взаимовыгодных условиях!

Наши преимущества:

- Поставка оригинальных импортных электронных компонентов напрямую с производств Америки, Европы и Азии, а так же с крупнейших складов мира;
- Широкая линейка поставок активных и пассивных импортных электронных компонентов (более 30 млн. наименований);
- Поставка сложных, дефицитных, либо снятых с производства позиций;
- Оперативные сроки поставки под заказ (от 5 рабочих дней);
- Экспресс доставка в любую точку России;
- Помощь Конструкторского Отдела и консультации квалифицированных инженеров;
- Техническая поддержка проекта, помощь в подборе аналогов, поставка прототипов;
- Поставка электронных компонентов под контролем ВП;
- Система менеджмента качества сертифицирована по Международному стандарту ISO 9001;
- При необходимости вся продукция военного и аэрокосмического назначения проходит испытания и сертификацию в лаборатории (по согласованию с заказчиком);
- Поставка специализированных компонентов военного и аэрокосмического уровня качества (Xilinx, Altera, Analog Devices, Intersil, Interpoint, Microsemi, Actel, Aeroflex, Peregrine, VPT, Syfer, Eurofarad, Texas Instruments, MS Kennedy, Miteq, Cobham, E2V, MA-COM, Hittite, Mini-Circuits, General Dynamics и др.);

Компания «Океан Электроники» является официальным дистрибьютором и эксклюзивным представителем в России одного из крупнейших производителей разъемов военного и аэрокосмического назначения «JONHON», а так же официальным дистрибьютором и эксклюзивным представителем в России производителя высокотехнологичных и надежных решений для передачи СВЧ сигналов «FORSTAR».



## JONHON

«JONHON» (основан в 1970 г.)

Разъемы специального, военного и аэрокосмического назначения:

(Применяются в военной, авиационной, аэрокосмической, морской, железнодорожной, горно- и нефтедобывающей отраслях промышленности)

«FORSTAR» (основан в 1998 г.)

ВЧ соединители, коаксиальные кабели, кабельные сборки и микроволновые компоненты:

(Применяются в телекоммуникациях гражданского и специального назначения, в средствах связи, РЛС, а так же военной, авиационной и аэрокосмической отраслях промышленности).



Телефон: 8 (812) 309-75-97 (многоканальный)

Факс: 8 (812) 320-03-32

Электронная почта: [ocean@oceanchips.ru](mailto:ocean@oceanchips.ru)

Web: <http://oceanchips.ru/>

Адрес: 198099, г. Санкт-Петербург, ул. Калинина, д. 2, корп. 4, лит. А