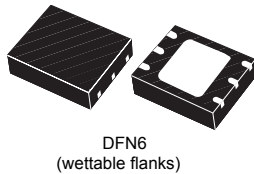


## 400 mA, 38 V low-dropout regulator, with 45 $\mu$ A quiescent current



### Features

- Low quiescent current: typ. 45  $\mu$ A at no load
- Wide input voltage operating range up to 38 V
- Low startup voltage: 3.5 V
- Output current up to 400 mA
- Output voltage options: Adj from 2.5 V and fixed, 3.0, 3.3, 5.0 and 8.5 V
- Output voltage accuracy:
  - $\pm 1\%$  typ. @ 25 °C
  - $\pm 3\%$  (including line, load and temperature variation)
- Ultra low-dropout:
  - 36 mV @ 100 mA load current
  - 140 mV @ 400 mA load current
- High PSRR: 70 dB @ 1 kHz
- Very low noise: 20  $\mu$ V<sub>RMS</sub>/V<sub>OUT</sub>
- Protection features: current limitation, thermal shutdown
- -40 °C to +125 °C operating temperature range
- Package: DFN6 (3x3) (wetable flanks)
- AEC-Q100 qualified (grade 1)

### Applications

- Automotive applications
- Body control modules
- Instruments and clusters
- Automotive LED lighting



Maturity status link

[LDO40L](#)

### Description

The **LDO40L** is a 400 mA LDO regulator, designed for being used in severe automotive environments.

Low quiescent current makes it suitable for applications permanently connected to battery. This feature is especially critical when electronic modules remain in active mode when ignition is off.

The **LDO40L** embeds protection functions, such as: current limit and thermal shutdown.

The extended input voltage range, low drop voltage and low quiescent current features make it suitable also for low power industrial and consumer applications.

# 1 Block diagram

Figure 1. Block diagram, fixed version

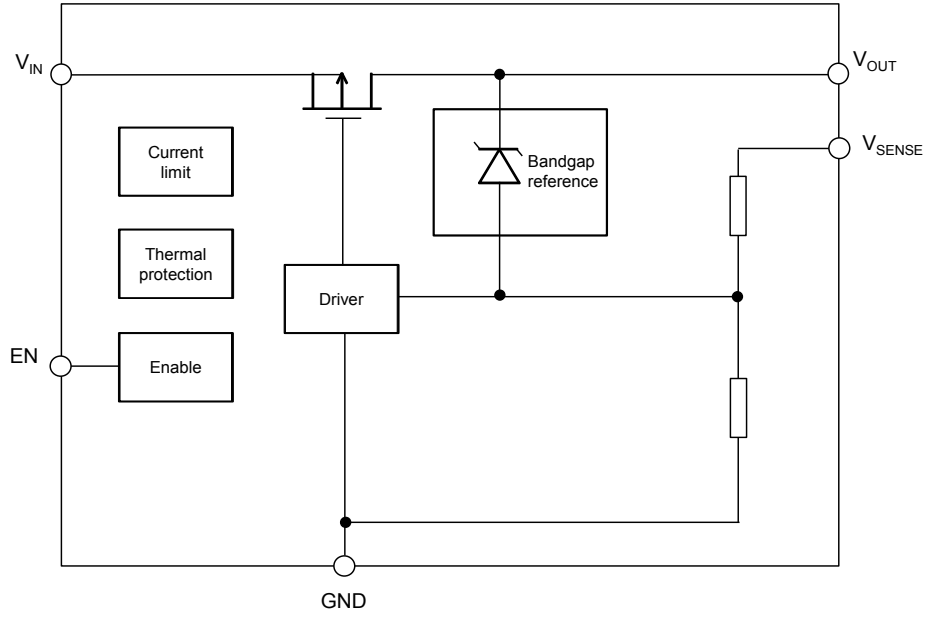
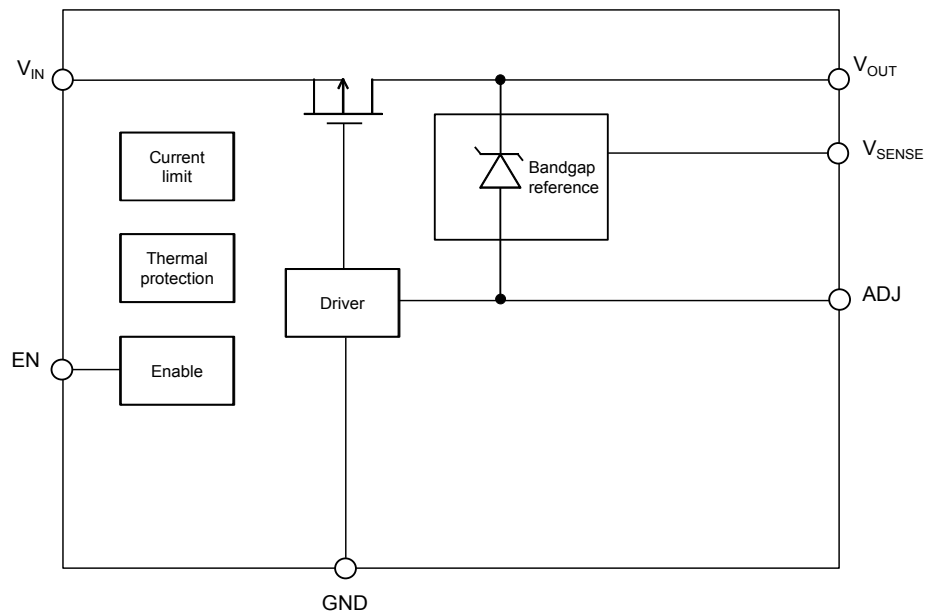


Figure 2. Block diagram, adjustable version



## 2 Pin configuration

Figure 3. Pin configuration (marking view)

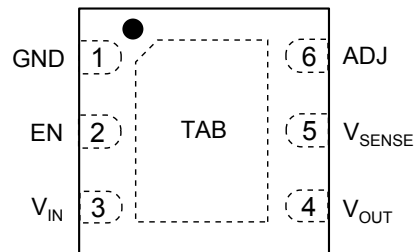
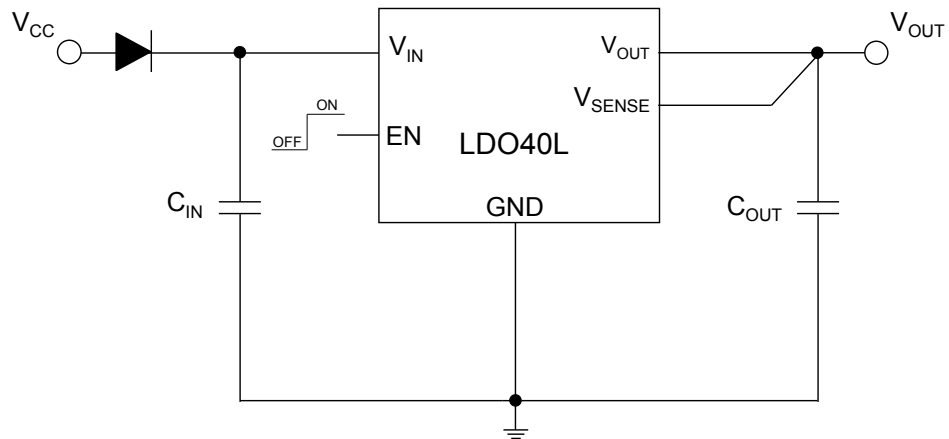
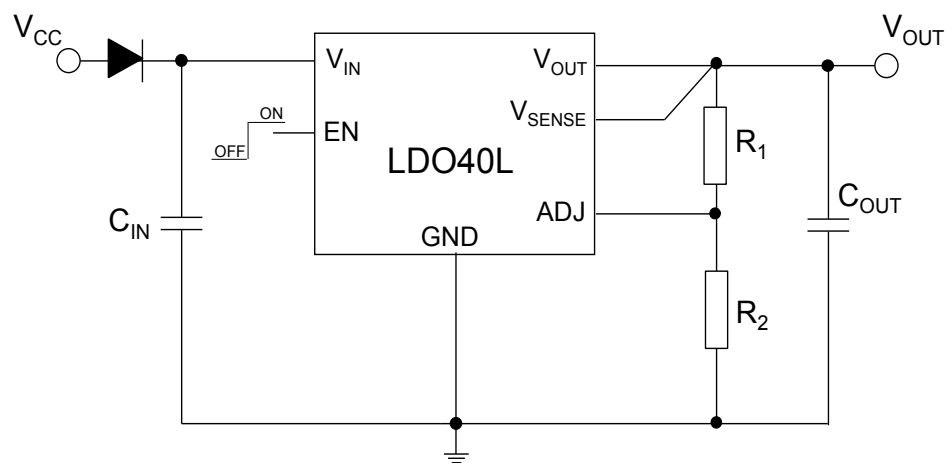


Table 1. Pin description (adjustable version)

| Symbol            | Pin n°      | Description                                                                                                                       |
|-------------------|-------------|-----------------------------------------------------------------------------------------------------------------------------------|
| $V_{IN}$          | 3           | LDO supply voltage                                                                                                                |
| GND               | 1           | Ground                                                                                                                            |
| $V_{OUT}$         | 4           | LDO output voltage                                                                                                                |
| EN                | 2           | Enable input: set $V_{EN}$ = high to turn on the device<br>$V_{EN}$ = low to turn off the device<br>Don't leave this pin floating |
| $V_{SENSE}$       | 5           | Output sensing pin. It must be connected to $V_{OUT}$                                                                             |
| ADJ               | 6           | Adjust pin. Connect a resistor divider to set the output voltage                                                                  |
| TAB / Exposed pad | Exposed pad | It must be connected to GND                                                                                                       |

### 3 Typical application diagram

**Figure 4. Typical application diagram (fixed versions)**

**Figure 5. Typical application diagram (adjustable versions)**


## 4 Absolute maximum ratings

**Table 2. Absolute maximum ratings**

| Symbol                  | Parameter                            | Value              | Unit               |
|-------------------------|--------------------------------------|--------------------|--------------------|
| $V_{IN}$                | Input supply voltage                 | -0.3 to 40         | V                  |
| $V_{OUT}$ , $V_{SENSE}$ | Output voltage                       | -0.3 to 12         | V                  |
| $V_{ADJ}$               | Adjust pin voltage                   | -0.3 to $V_{OUT}$  | V                  |
| $V_{EN}$                | Enable pin voltage                   | -0.3 to $V_{IN}$   | V                  |
| $I_{OUT}$               | Output current                       | Internally limited | A                  |
| $P_D$                   | Power dissipation                    | Internally limited | W                  |
| ESD                     | Charge device model                  | $\pm 500$          | V                  |
|                         | Human body model                     | $\pm 2000$         |                    |
| $T_J$                   | Operating junction temperature range | -40 to 150         | $^{\circ}\text{C}$ |
| $T_{STG}$               | Storage temperature                  | -65 to 150         | $^{\circ}\text{C}$ |

*Note:* Absolute maximum ratings are those values beyond which damage to the device may occur. Functional operation under these conditions is not implied. All values are referred to GND.

**Table 3. Thermal data**

| Symbol     | Parameter                               | DFN6 | Unit                        |
|------------|-----------------------------------------|------|-----------------------------|
| $R_{thJA}$ | Thermal resistance, junction-to-ambient | 42   | $^{\circ}\text{C}/\text{W}$ |
| $R_{thJC}$ | Thermal resistance, junction-to-case    | 5    | $^{\circ}\text{C}/\text{W}$ |

*Note:*  $R_{thJA}$  for DFN6 based on a 4-layer JEDEC PCB (2S2P) test board with 2 thermal vias.

## 5 Electrical characteristics

Unless otherwise specified:  $T_J = -40$  to  $125$  °C;  $V_{IN} = 13.2$  V,  $V_{OUT} = 5$  V,  $V_{EN} = 5$  V,  $I_{OUT} = 1$  mA;  $C_{IN} = C_{OUT} = 1$   $\mu$ F; Typical values referred to  $T_A = 25$  °C.

**Table 4. Electrical characteristics**

| Symbol                                  | Parameter                                                                  | Test conditions                                                                                              | Min.                 | Typ.   | Max.  | Unit                                  |
|-----------------------------------------|----------------------------------------------------------------------------|--------------------------------------------------------------------------------------------------------------|----------------------|--------|-------|---------------------------------------|
| $V_{IN}$                                | Operating input voltage range<br>(see Section 6.1 Operating input voltage) | Device On                                                                                                    | 3.5                  |        | 38    | V                                     |
|                                         |                                                                            | Minimum input voltage for regulation <sup>(1)</sup>                                                          | $V_{OUT} + V_{DROP}$ |        | 38    | V                                     |
| $V_{OUT}$                               | Operating output voltage range                                             |                                                                                                              | 2.5                  |        | 11    | V                                     |
| $V_{OUT}$                               | Output voltage accuracy<br>(fixed version)                                 | $V_{OUT} + 1$ V <sup>(2)</sup> < $V_{IN} < 18$ V,<br>0.1 mA < $I_{OUT} < 400$ mA,<br>-40 °C < $T_J < 125$ °C | -3                   |        | 3     | %                                     |
|                                         |                                                                            | $T_J = 25$ °C                                                                                                | -1                   |        | 1     |                                       |
| $V_{REF}$                               | Reference voltage<br>(adjustable version) ( $V_{OUT} - V_{ADJ}$ )          | $V_{OUT} + 1$ V <sup>(2)</sup> < $V_{IN} < 18$ V,<br>0.1 mA < $I_{OUT} < 400$ mA,<br>-40 °C < $T_J < 125$ °C | 1.164                | 1.2    | 1.236 | V                                     |
|                                         |                                                                            | $T_J = 25$ °C                                                                                                | 1.188                |        | 1.212 |                                       |
| $\frac{\Delta V_{OUT}}{\Delta V_{IN}}$  | Static line regulation                                                     | $V_{OUT} + 1$ V <sup>(2)</sup> < $V_{IN} < 18$ V;<br>$I_{OUT} = 1$ mA                                        |                      | 0.002  | 0.02  | %/V                                   |
| $\frac{\Delta V_{OUT}}{\Delta I_{OUT}}$ | Static load regulation                                                     | 0.1 mA < $I_{OUT} < 400$ mA                                                                                  |                      | 0.0001 | 0.002 | %/mA                                  |
| $V_{DROP}$                              | Dropout voltage <sup>(3)</sup>                                             | $I_{OUT} = 0.1$ A; $V_{OUT} = 5$ V                                                                           |                      | 36     | 70    | mV                                    |
|                                         |                                                                            | $I_{OUT} = 0.4$ A; $V_{OUT} = 5$ V                                                                           |                      | 140    | 270   |                                       |
| eN                                      | Output noise voltage                                                       | f = 10 Hz to 100 kHz;<br>$I_{OUT} = 10$ mA                                                                   |                      | 20     |       | $\mu$ V <sub>RMS</sub> /<br>$V_{OUT}$ |
| SVR                                     | Supply voltage rejection                                                   | $V_{OUT} = 5$ V, f = 100 Hz;<br>$I_{OUT} = 10$ mA                                                            |                      | 77     |       | dB                                    |
|                                         |                                                                            | $V_{OUT} = 5$ V, f = 1 kHz;<br>$I_{OUT} = 10$ mA                                                             |                      | 70     |       |                                       |
|                                         |                                                                            | $V_{OUT} = 5$ V, f = 10 kHz;<br>$I_{OUT} = 10$ mA                                                            |                      | 45     |       |                                       |
|                                         |                                                                            | $V_{OUT} = 11$ V, f = 100 Hz;<br>$I_{OUT} = 10$ mA                                                           |                      | 77     |       |                                       |
|                                         |                                                                            | $V_{OUT} = 11$ V, f = 1 kHz;<br>$I_{OUT} = 10$ mA                                                            |                      | 68     |       |                                       |
|                                         |                                                                            | $V_{OUT} = 11$ V, f = 10 kHz;<br>$I_{OUT} = 10$ mA                                                           |                      | 42     |       |                                       |

| Symbol            | Parameter                                  | Test conditions                                 | Min. | Typ. | Max. | Unit |
|-------------------|--------------------------------------------|-------------------------------------------------|------|------|------|------|
| I <sub>Q</sub>    | Quiescent current                          | I <sub>OUT</sub> = 0 to 1 mA                    |      | 45   | 90   | μA   |
|                   |                                            | I <sub>OUT</sub> = 400 mA                       |      | 80   | 140  |      |
|                   | Shutdown current                           | V <sub>EN</sub> = 0 V, V <sub>IN</sub> = 13.2 V |      | 0.2  | 2.2  | μA   |
| I <sub>ADJ</sub>  | Adjustable input current                   |                                                 |      |      | 1    | μA   |
| I <sub>SC</sub>   | Short-circuit current                      | V <sub>IN</sub> = 6 V, V <sub>OUT</sub> = 0 V   | 1.2  | 1.6  |      | A    |
| V <sub>EN</sub>   | Enable input logic low, V <sub>EN-L</sub>  |                                                 |      |      | 0.65 | V    |
|                   | Enable input logic high, V <sub>EN-H</sub> |                                                 | 2.7  |      |      |      |
| I <sub>EN</sub>   | Enable pin input current                   | V <sub>IN</sub> = 6 V, V <sub>EN</sub> = 5 V    |      | 0.5  | 1.5  | μA   |
| T <sub>SHDN</sub> | Thermal shutdown                           |                                                 |      | 175  |      | °C   |
|                   | Hysteresis                                 |                                                 |      | 25   |      |      |

1.  $V_{IN-MIN} = V_{OUT} + V_{DROP}$  or 5 V, whichever is greater.
2.  $V_{IN} = V_{OUT} + 1$  V or 5 V, whichever is greater.
3. Dropout voltage is the input-to-output voltage difference at which the output voltage is 100 mV below its nominal value.

## 6 Application information

### 6.1 Operating input voltage

The LDO40L is a low-dropout linear voltage regulator equipped with a low- $R_{DS(on)}$  P-channel MOSFET used as a pass-element. The device internal circuits are able to start with an input voltage as low as 3.5 V, whatever is the nominal output voltage (see [Figure 22. Output voltage vs. input voltage \(no load\)](#)). Defined the desired output voltage  $V_{OUT-NOM}$ , the minimum input voltage  $V_{IN-MIN}$  needed to fully bias the pass-element, is

$V_{IN-MIN} = V_{OUT-NOM} + V_{DROP}$ . This allows to exit the dropout condition and achieve output voltage regulation.

The full regulation performance guaranteed by [Section 5 Electrical characteristics](#) in terms of output accuracy and tolerance versus line and load changes is achieved for the highest input voltage among  $V_{IN-MIN} = V_{OUT-NOM} + 1\text{ V}$  and  $V_{IN-MIN} = 5\text{ V}$ .

At input voltages lower than  $V_{IN-MIN} = (V_{OUT-NOM} + V_{DROP})$  the regulator enters dropout condition, regulation is not guaranteed and the output voltage tracks the input except for a voltage depending on the load current ( $I_{OUT}$ ) and the pass-element resistance (see [Figure 22. Output voltage vs. input voltage \(no load\)](#)). This tracking behavior can be useful during cold crank conditions.

### 6.2 Output voltage adjustment

The LDO40LY is available in fixed and adjustable output voltage versions. The latter option is usually chosen when the output voltage has to be set to non-standard values. In the adjustable version, the output voltage can be set from 2.5 V up to 11 V, by connecting a resistor divider between the ADJ pin and the output.

The architecture of the LDO40LY features a precise bandgap reference, which generates a fixed voltage  $V_{REF} = 1.2\text{ V}$  between  $V_{OUT}$  and ADJ terminals (refer to [Figure 2. Block diagram, adjustable version](#) and [Figure 5. Typical application diagram \(adjustable versions\)](#)). When the R1-R2 resistor divider is connected, a fixed current is generated through the divider. Since the contribution of current sourced by the ADJ pin is negligible (few tens of nA), the resulting output voltage is obtained by using the following equation:

$$V_{OUT} = V_{REF}(1 + R2/R1), \text{ with } V_{REF} = 1.2V(\text{typ.}) \quad (1)$$

In order to guarantee a correct regulation, the resistor divider must be calculated for an output voltage of min. 2.5 V.

### 6.3 Output voltage sense pin

In the DFN6 package on pin 5, an additional  $V_{SENSE}$  connection is available. This pin must not be left floating, since it is necessary for a correct sensing of the output voltage. It can be either connected to the load in a remote-sensing configuration, or directly shorted to the  $V_{OUT}$  pin (pin 4, refer to [Figure 4. Typical application diagram \(fixed versions\)](#) and [Figure 5. Typical application diagram \(adjustable versions\)](#)).

### 6.4 Protection features

The device is self-protected from short-circuits and overtemperature events.

In case of strong overload or short-circuit on the output, the output current is limited to a value of typically 1.5 A and kept constant even when the load impedance is zero. If the overload persists, the temperature on the internal die rises, until the thermal protection is triggered, which happens when the junction temperature reaches 175 °C. The device is subsequently shut down. As soon as the junction temperature falls again below 150 °C the device re-starts.

Even if the above described protections are able to keep the device safe in the worst cases, a correct thermal design of the application is recommended, according to the operating ambient temperature and the maximum power dissipation allowed by the chosen package. In order to calculate the maximum power that the device can dissipate, keeping the junction temperature below  $T_{J-OP} = 125\text{ °C}$ , the following formula is used:

$$P_{DMAX} = (125 - T_{AMB}) / R_{THJ-A} \quad (2)$$



The power dissipation on the device is calculated as  $P_D = (V_{IN} - V_{OUT}) \times I_{OUT}$ .

## 6.5 Enable pin

The enable function allows the LDO output to be enabled/disabled. The regulator is turned on in case the pin EN is connected to a voltage higher than  $V_{EN-H}$ , the LDO can be turned off if the voltage on EN pin is lower than  $V_{EN-L}$ .

No internal pull-up / pull-down is present on the EN pin, therefore it must not be left floating in the application.

## 6.6 Input and output capacitors

The LDO40LY requires external capacitors to ensure the regulator control loop stability.

A capacitor with a minimum value of 1  $\mu\text{F}$  is required on at the input port of the LDO40LY.

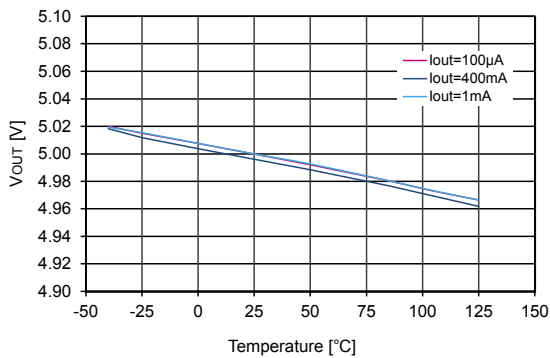
This capacitor must be located as close as possible to the input pin of the device and returned to a clean analog ground. Good quality ceramic capacitors are suggested.

The device control loop is designed to be stable with good quality ceramic capacitors (such as: X5R/X7R types) with a minimum capacitance of 1  $\mu\text{F}$  and equivalent series resistance in the [5 m $\Omega$  – 12  $\Omega$ ] range. There is no upper limit to the output capacitance. [Figure 27. Stability plan](#) shows the stability plan tested on real capacitors, up to 10  $\mu\text{F}$ . A value of 4.7  $\mu\text{F}$  is suitable for the majority of applications, improving dynamic response and minimizing the risk of ringing and oscillations. It is important to highlight that the output capacitor must maintain its capacitance and ESR in the stable region over the full operating temperature, load and input voltage ranges, to assure stability. Therefore, capacitance and ESR variations must be taken into account in the design phase to ensure the device works in the expected stability region. There is no maximum limit to the output capacitance, provided that the above conditions are respected.

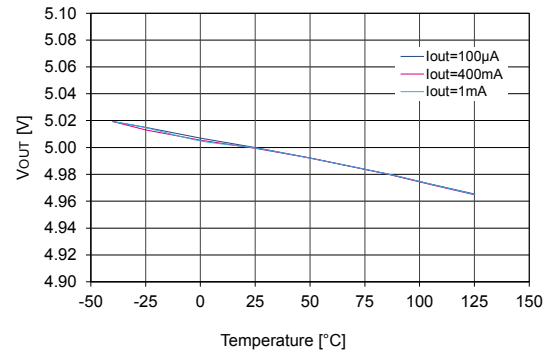
## 7 Typical characteristics

The following plots are referred to the typical application circuit with  $C_{IN} = C_{OUT} = 1 \mu\text{F}$  and  $T_A = 25^\circ\text{C}$  unless otherwise noted.

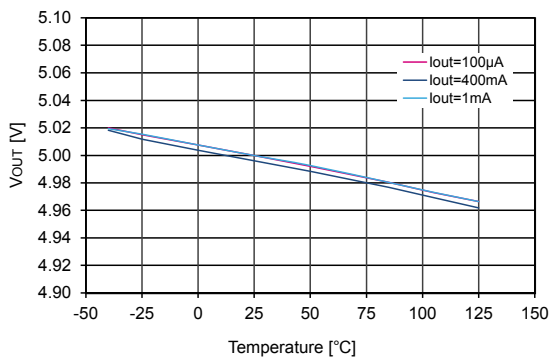
**Figure 6. Output voltage vs. temperature ( $V_{IN} = 6 \text{ V}$ ,  $V_{OUT} = \text{adjusted to } 5 \text{ V}$ )**



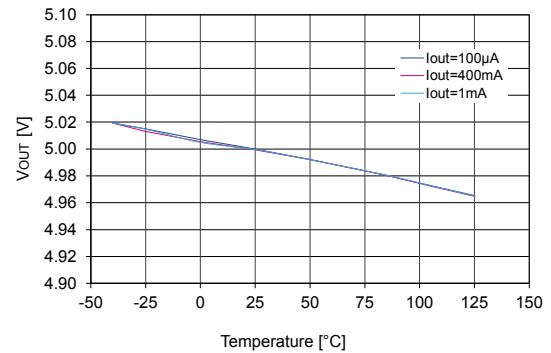
**Figure 7. Output voltage vs. temperature ( $V_{IN} = 13.2 \text{ V}$ ,  $V_{OUT} = \text{adjusted to } 5 \text{ V}$ )**

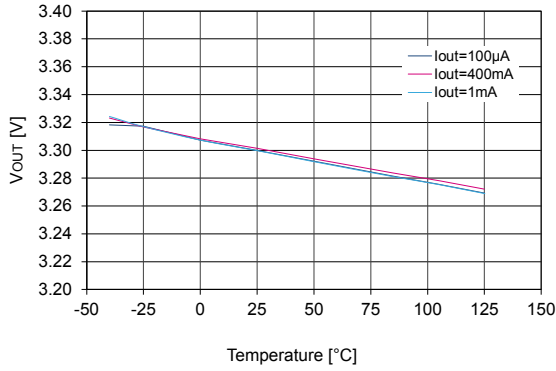
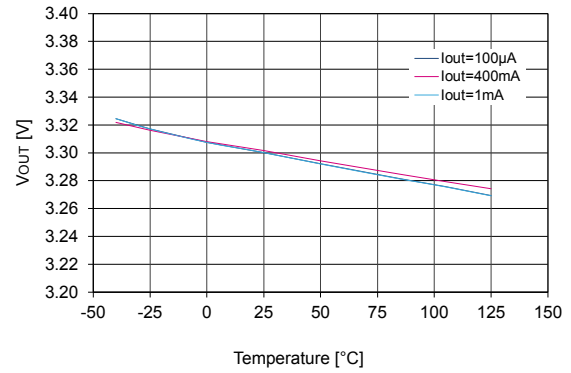
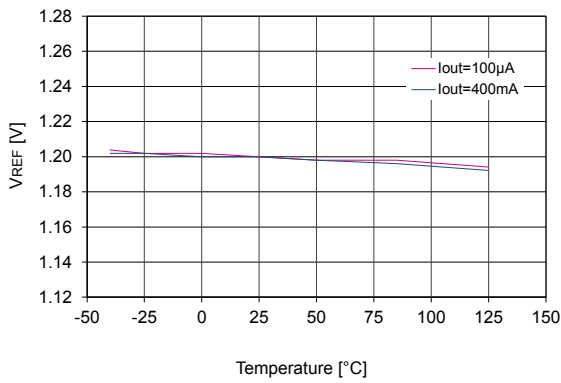
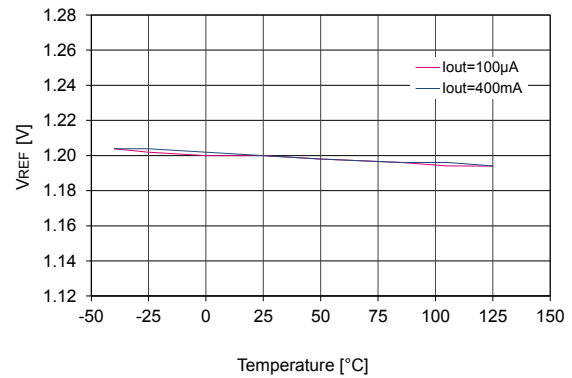
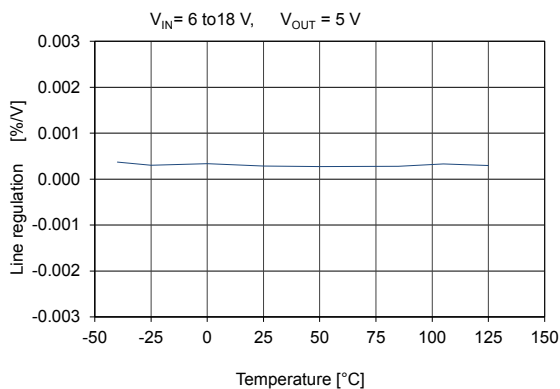
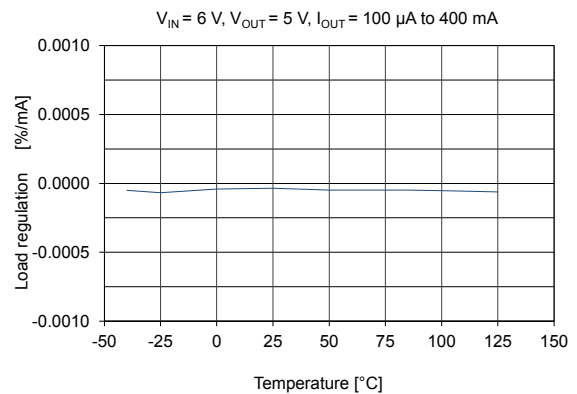


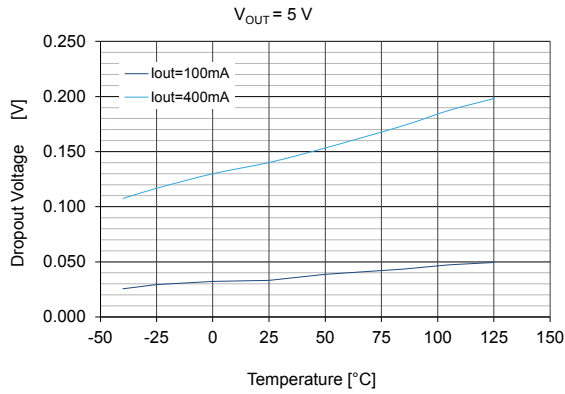
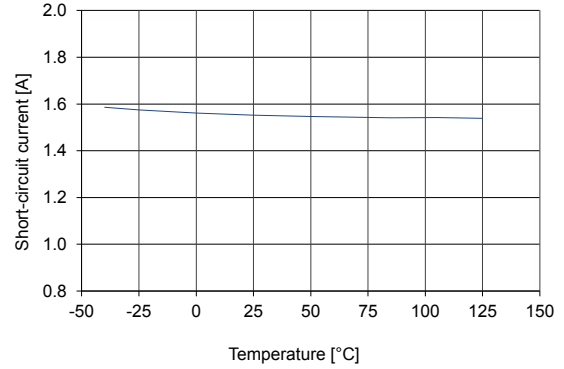
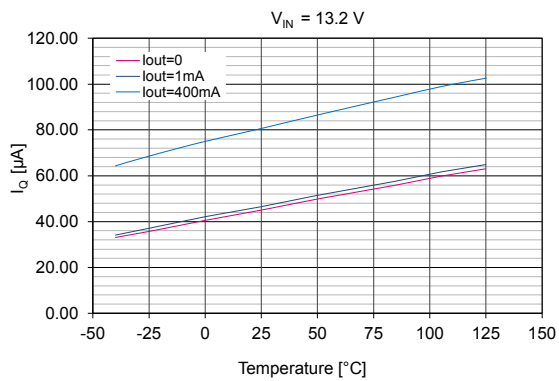
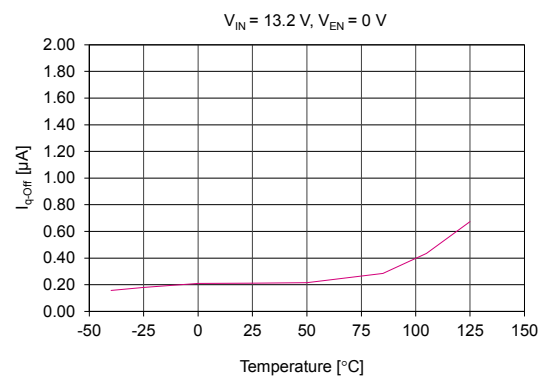
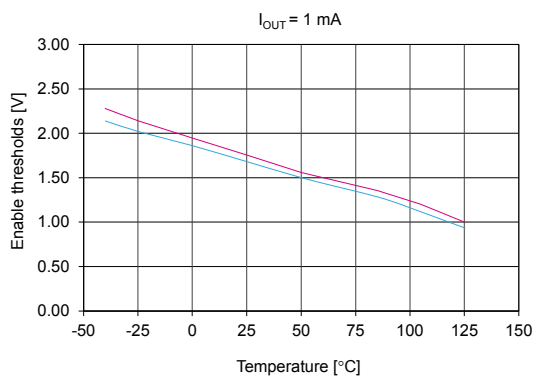
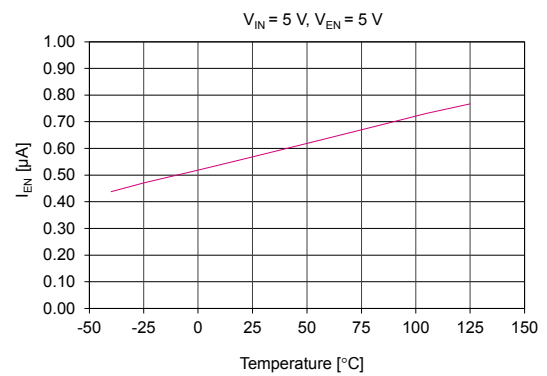
**Figure 8. Output voltage vs. temperature ( $V_{IN} = 18 \text{ V}$ ,  $V_{OUT} = \text{adjusted to } 5 \text{ V}$ )**

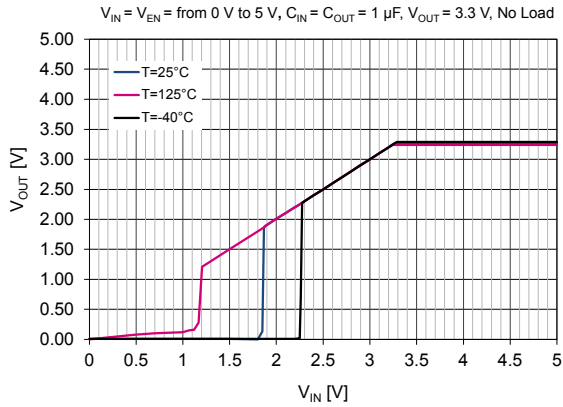
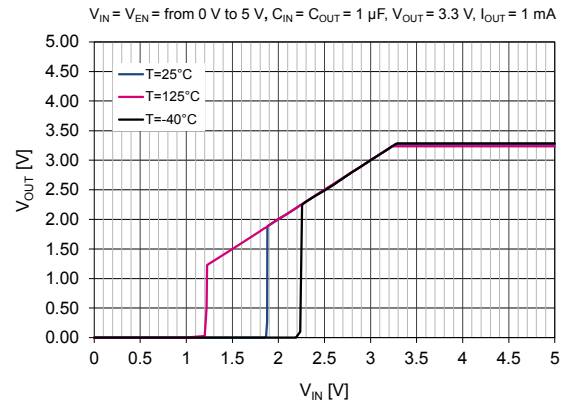
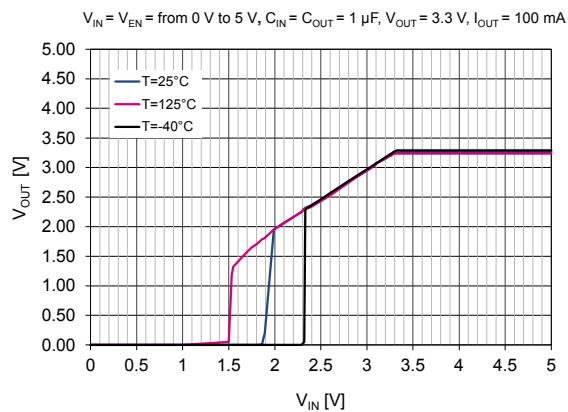
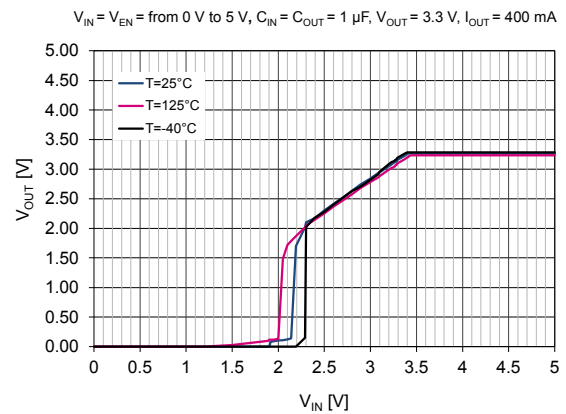
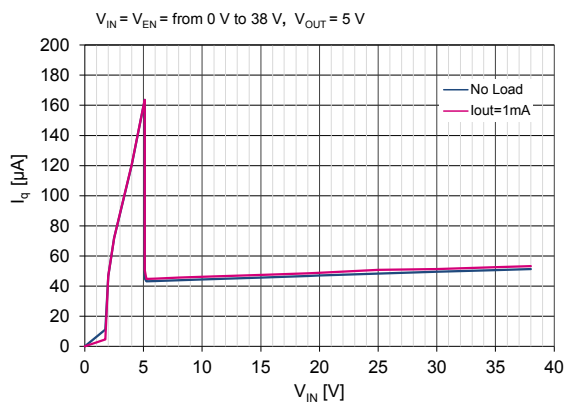
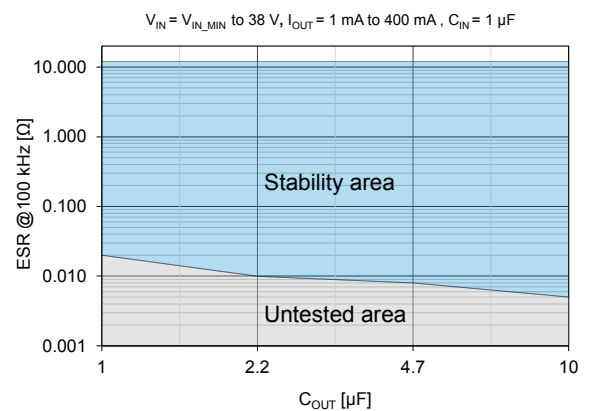


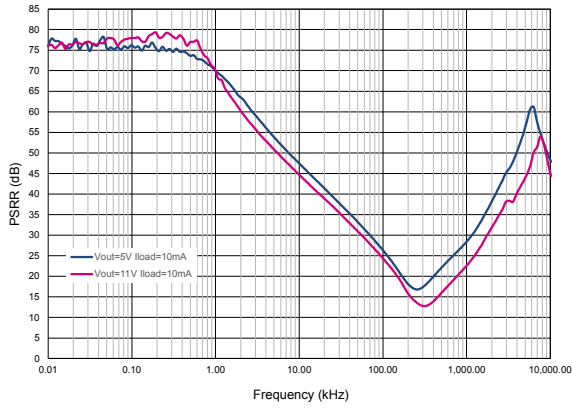
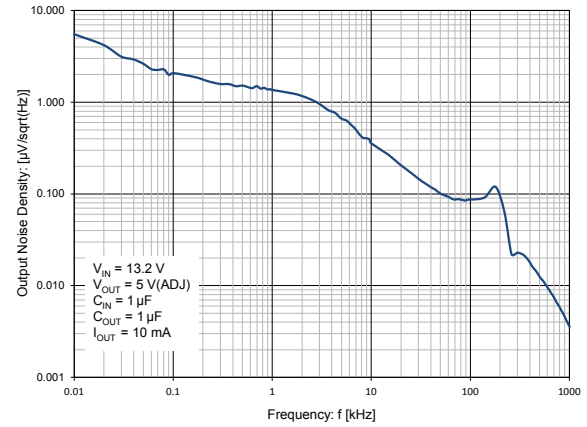
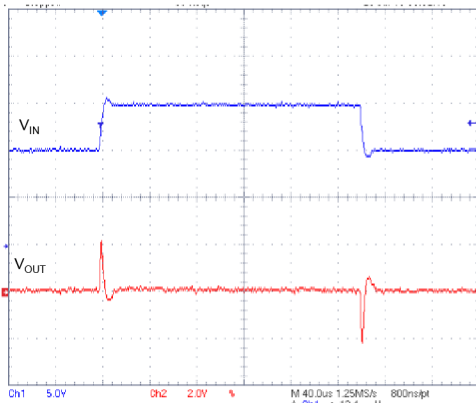
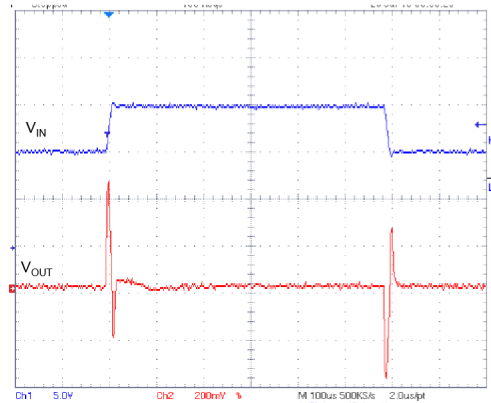
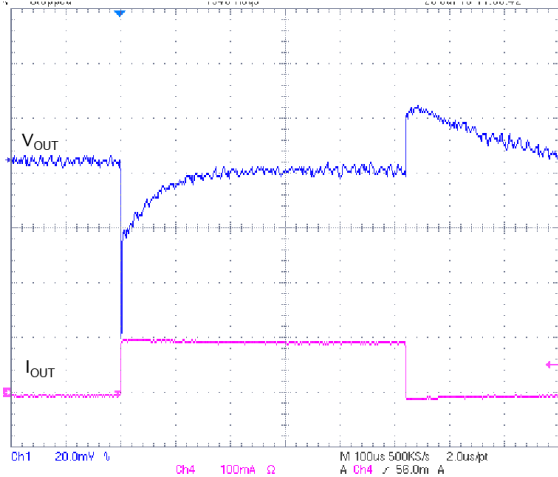
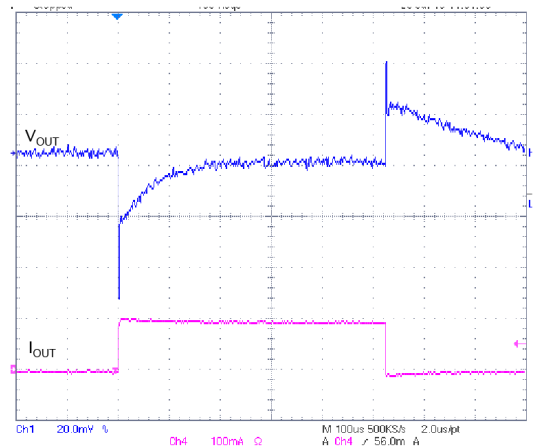
**Figure 9. Output voltage vs. temperature ( $V_{IN} = 4.3 \text{ V}$ ,  $V_{OUT} = 3.3 \text{ V}$ )**

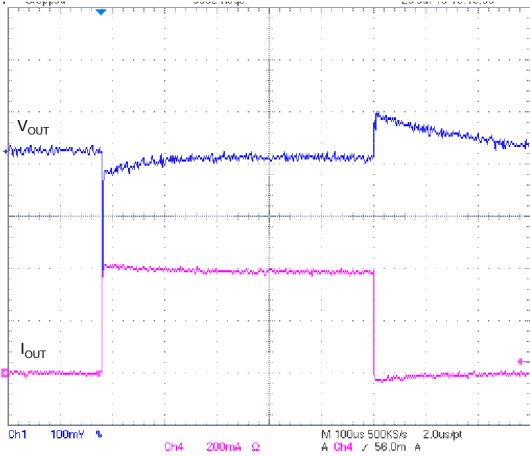
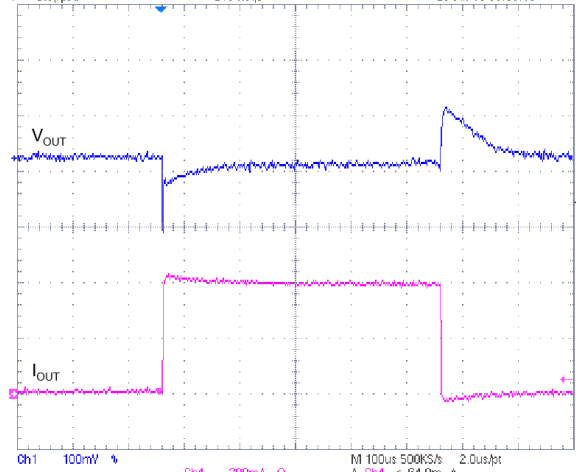
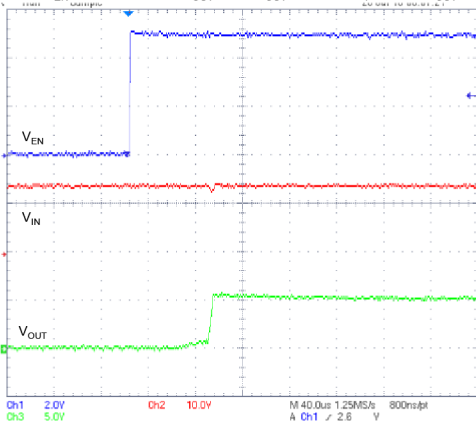
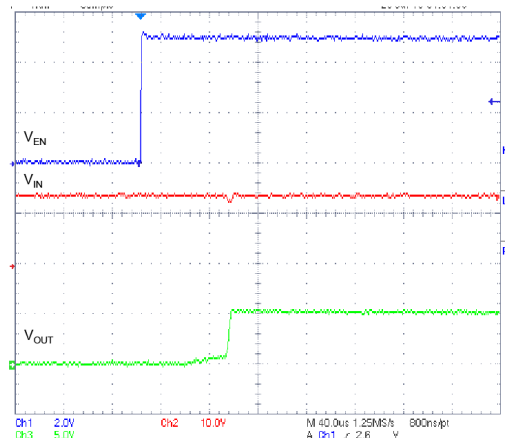
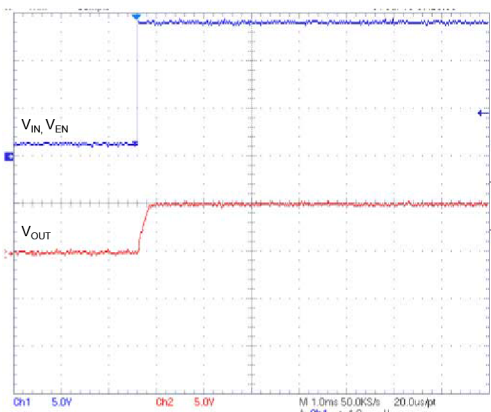
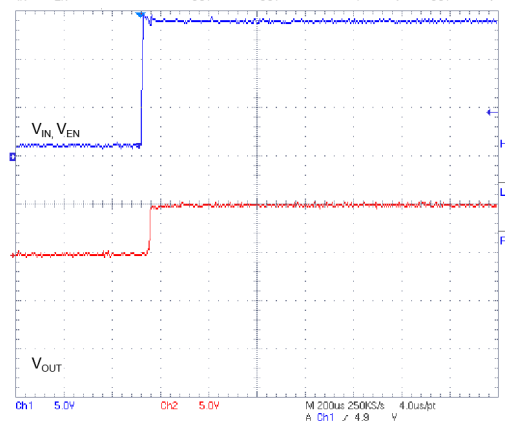


**Figure 10. Output voltage vs. temperature ( $V_{IN} = 13.2\text{ V}$ ,  $V_{OUT} = 3.3\text{ V}$ )**

**Figure 11. Output voltage vs. temperature ( $V_{IN} = 18\text{ V}$ ,  $V_{OUT} = 3.3\text{ V}$ )**

**Figure 12. Reference voltage vs. temperature ( $V_{IN} = 6\text{ V}$ ,  $V_{OUT} = \text{adjusted to } 5\text{ V}$ )**

**Figure 13. Reference voltage vs. temperature ( $V_{IN} = 18\text{ V}$ ,  $V_{OUT} = \text{adjusted to } 5\text{ V}$ )**

**Figure 14. Line regulation vs. temperature**

**Figure 15. Load regulation vs. temperature**


**Figure 16. Dropout voltage vs. temperature**

**Figure 17. Short-circuit current vs. temperature**

**Figure 18. Quiescent current vs. temperature**

**Figure 19. Off-state current vs. temperature**

**Figure 20. Enable thresholds vs. temperature**

**Figure 21. Enable input current vs. temperature**


**Figure 22. Output voltage vs. input voltage (no load)**

**Figure 23. Output voltage vs. input voltage ( $I_{OUT} = 1 \text{ mA}$ )**

**Figure 24. Output voltage vs. input voltage ( $I_{OUT} = 100 \text{ mA}$ )**

**Figure 25. Output voltage vs. input voltage ( $I_{OUT} = 400 \text{ mA}$ )**

**Figure 26. Quiescent current vs. input voltage**

**Figure 27. Stability plan**


**Figure 28. PSRR vs. frequency**

**Figure 29. Output noise spectrum**

**Figure 30. Line transient ( $t_r = t_f = 1 \mu s$ )**
 $V_{IN}$  from 10 V to 15 V,  $V_{OUT} = 5$  V,  $I_{OUT} = 1$  mA,  $t_r = t_f = 1 \mu s$ ,  $C_{OUT} = 2.2 \mu F$ 

**Figure 31. Line transient ( $t_r = t_f = 10 \mu s$ )**
 $V_{IN}$  from 10 V to 15 V,  $V_{OUT} = 5$  V,  $I_{OUT} = 1$  mA,  $t_r = t_f = 10 \mu s$ ,  $C_{OUT} = 2.2 \mu F$ 

**Figure 32. Load transient (0.1 mA to 100 mA,  $t_r = t_f = 1 \mu s$ )**
 $V_{IN} = 13.2$  V,  $V_{OUT} = 5$  V,  $I_{OUT}$  = from 0.1 mA to 100 mA,  $t_r = t_f = 1 \mu s$ ,  $C_{OUT} = 10 \mu F$ 

**Figure 33. Load transient (0.1 mA to 100 mA,  $t_r = t_f = 10 \mu s$ )**
 $V_{IN} = 13.2$  V,  $V_{OUT} = 5$  V,  $I_{OUT}$  = from 0.1 mA to 100 mA,  $t_r = t_f = 10 \mu s$ ,  $C_{OUT} = 10 \mu F$ 


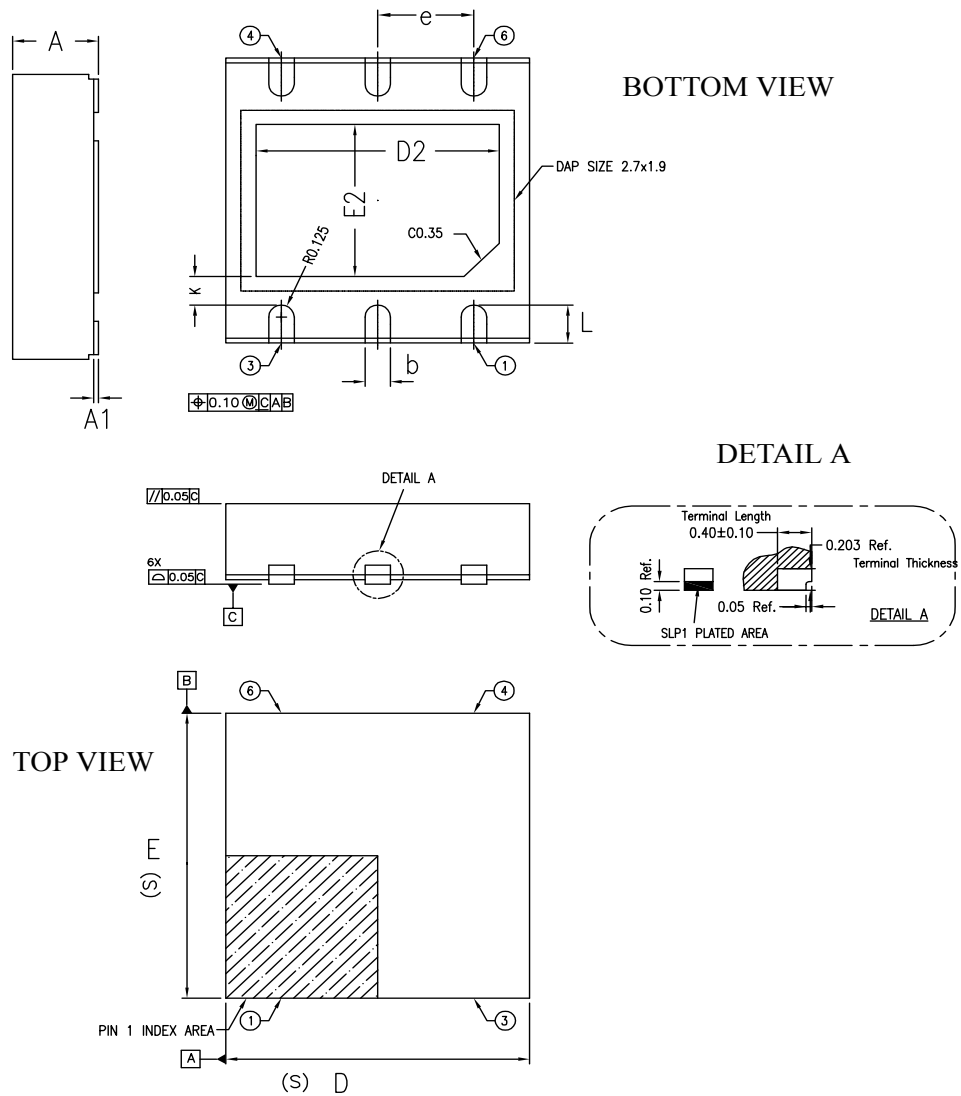
**Figure 34. Load transient ( $I_{OUT} = 1\text{ mA}$  to  $400\text{ mA}$ ,  $t_r = t_f = 1\text{ }\mu\text{s}$ )**
 $V_{IN} = 13.2\text{ V}$ ,  $V_{OUT} = 5\text{ V}$ ,  $I_{OUT} = \text{from } 1\text{ mA to } 400\text{ mA}$ ,  $t_r = t_f = 1\text{ }\mu\text{s}$ ,  $C_{OUT} = 10\text{ }\mu\text{F}$ 

**Figure 35. Load transient ( $I_{OUT} = 1\text{ mA}$  to  $400\text{ mA}$ ,  $t_r = t_f = 10\text{ }\mu\text{s}$ )**
 $V_{IN} = 13.2\text{ V}$ ,  $V_{OUT} = 5\text{ V}$ ,  $I_{OUT} = \text{from } 1\text{ mA to } 400\text{ mA}$ ,  $t_r = t_f = 10\text{ }\mu\text{s}$ ,  $C_{OUT} = 2.2\text{ }\mu\text{F}$ 

**Figure 36. Enable transient ( $I_{OUT} = 0.1\text{ mA}$ )**
 $V_{IN} = 14\text{ V}$ ,  $V_{EN} = \text{from } 0\text{ to } 5\text{ V}$ ,  $V_{OUT} = 5\text{ V}$ ,  $I_{OUT} = 0.1\text{ mA}$ ,  $t_r = 1\text{ }\mu\text{s}$ ,  $C_{OUT} = 2.2\text{ }\mu\text{F}$ 

**Figure 37. Enable transient ( $I_{OUT} = 400\text{ mA}$ )**
 $V_{IN} = 14\text{ V}$ ,  $V_{EN} = \text{from } 0\text{ to } 5\text{ V}$ ,  $V_{OUT} = 5\text{ V}$ ,  $I_{OUT} = 400\text{ mA}$ ,  $t_r = 1\text{ }\mu\text{s}$ ,  $C_{OUT} = 2.2\text{ }\mu\text{F}$ 

**Figure 38. Start-up transient ( $I_{OUT} = 0.1\text{ mA}$ )**
 $V_{IN} = V_{EN} = \text{from } 0\text{ to } 14\text{ V}$ ,  $V_{OUT} = 5\text{ V}$ ,  $I_{OUT} = 0.1\text{ mA}$ ,  $t_r = 10\text{ }\mu\text{s}$ ,  $C_{OUT} = 2.2\text{ }\mu\text{F}$ 

**Figure 39. Start-up transient ( $I_{OUT} = 400\text{ mA}$ )**
 $V_{IN} = V_{EN} = \text{from } 0\text{ to } 14\text{ V}$ ,  $V_{OUT} = 5\text{ V}$ ,  $I_{OUT} = 400\text{ mA}$ ,  $t_r = 10\text{ }\mu\text{s}$ ,  $C_{OUT} = 2.2\text{ }\mu\text{F}$ 


## 8 Package information

In order to meet environmental requirements, ST offers these devices in different grades of ECOPACK® packages, depending on their level of environmental compliance. ECOPACK® specifications, grade definitions and product status are available at: [www.st.com](http://www.st.com). ECOPACK® is an ST trademark.

### 8.1 DFN6 (3x3) package information

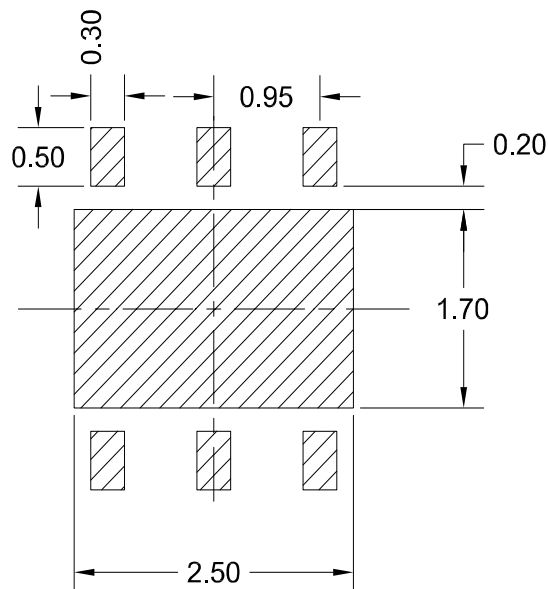
Figure 40. DFN6 (3x3) package outline

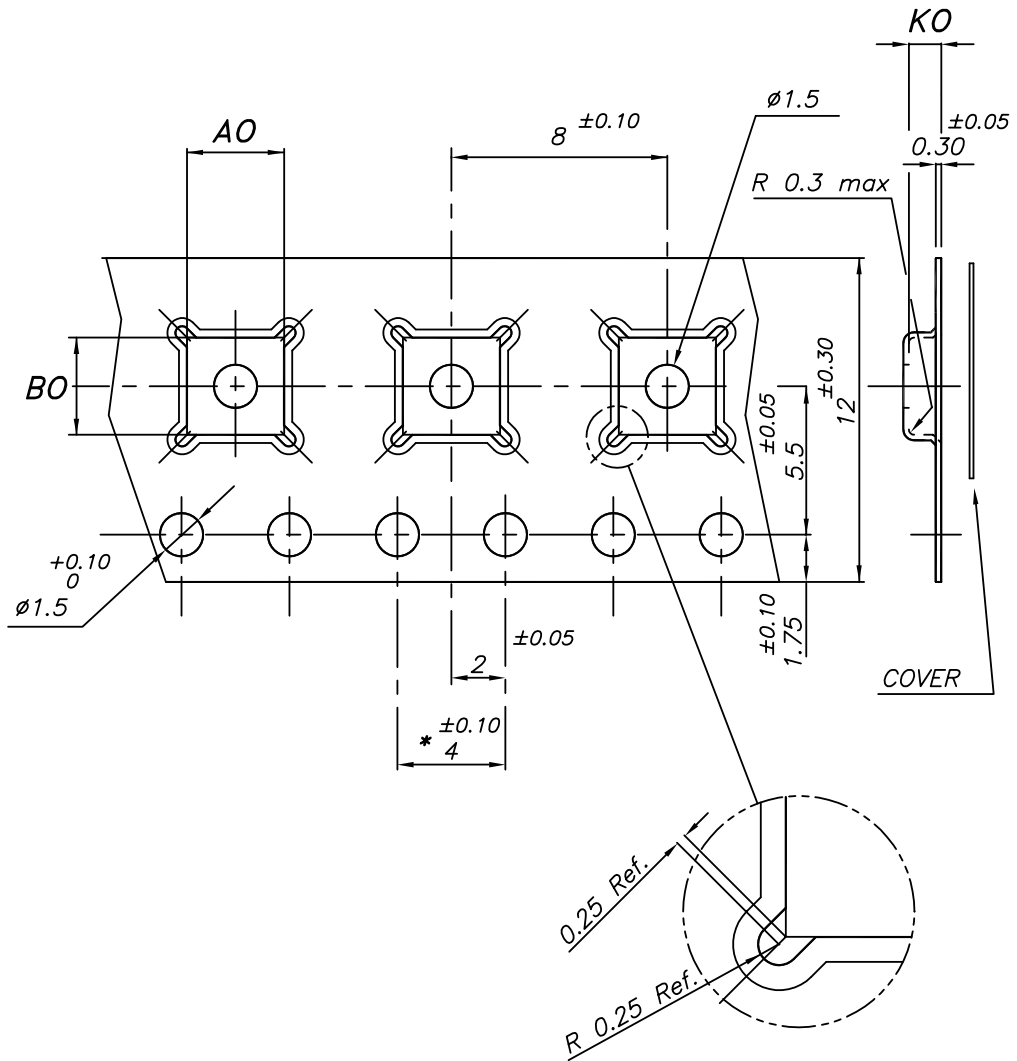




**Table 5. DFN6 (3x3) mechanical data**

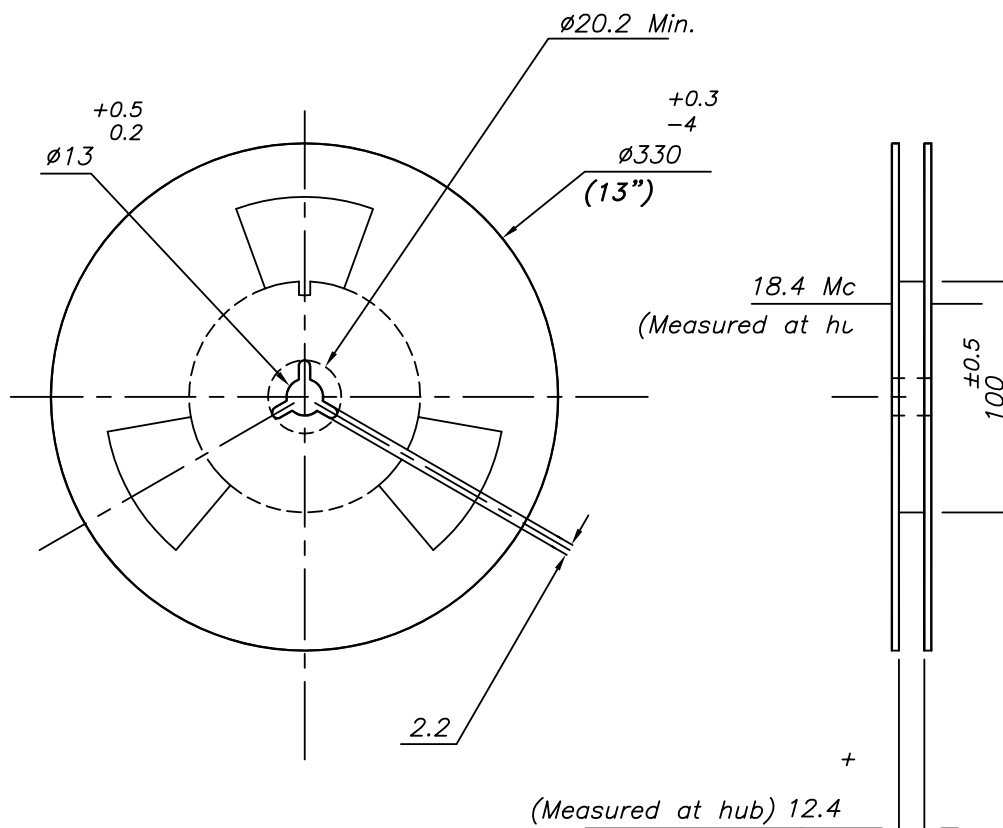
| Dim. | mm        |      |      |
|------|-----------|------|------|
|      | Min.      | Typ. | Max. |
| A    | 0.80      | 0.85 | 0.90 |
| A1   | 0.00      |      | 0.05 |
| b    | 0.20      | 0.25 | 0.30 |
| D    | 2.95      | 3.00 | 3.05 |
| D2   | 2.30      | 2.40 | 2.50 |
| e    | 0.95 BSC  |      |      |
| E    | 2.95      | 3.00 | 3.05 |
| E2   | 1.50      | 1.60 | 1.70 |
| L    | 0.30      | 0.40 | 0.50 |
| K    | 0.30 Ref. |      |      |
| aaa  | 0.10      |      |      |
| bbb  | 0.10      |      |      |
| ccc  | 0.10      |      |      |
| ddd  | 0.10      |      |      |

**Figure 41. DFN6 (3x3) recommended footprint (dimensions are in mm)**


**8.2 DFN6 (3x3) packing information**
**Figure 42. DFN6 (3x3) tape outline**


\* - 10 SPROCKET HOLE PITCH CUMULATIVE TOLERANCE ±0.20

7875978\_N

**Figure 43. DFN6 (3x3) reel outline**


7875978\_N

**Table 6. DFN6 (3x3) tape and reel mechanical data**

| Dim. | mm   |      |      |
|------|------|------|------|
|      | Min. | Typ. | Max. |
| A0   | 3.20 | 3.30 | 3.40 |
| B0   | 3.20 | 3.30 | 3.40 |
| K0   | 1    | 1.10 | 1.20 |

## 9 Ordering information

**Table 7. Order code**

| Order code   | Package | Output voltage | Total accuracy | Marking | Packing       |
|--------------|---------|----------------|----------------|---------|---------------|
| LDO40LPURY   | DFN6    | ADJ            | 3%             | 4LBA    | Tape and reel |
| LDO40LPU33RY | DFN6    | 3.3 V          | 3%             | 4LBC    | Tape and reel |
| LDO40LPU50RY | DFN6    | 5.0 V          | 3%             | 4LBD    | Tape and reel |

## Revision history

**Table 8. Document revision history**

| Date        | Revision | Changes          |
|-------------|----------|------------------|
| 04-Sep-2018 | 1        | Initial release. |

## Contents

|          |                                                |           |
|----------|------------------------------------------------|-----------|
| <b>1</b> | <b>Block diagram</b> .....                     | <b>2</b>  |
| <b>2</b> | <b>Pin configuration</b> .....                 | <b>3</b>  |
| <b>3</b> | <b>Typical application diagram</b> .....       | <b>4</b>  |
| <b>4</b> | <b>Absolute maximum ratings</b> .....          | <b>5</b>  |
| <b>5</b> | <b>Electrical characteristics</b> .....        | <b>6</b>  |
| <b>6</b> | <b>Application information</b> .....           | <b>8</b>  |
| 6.1      | Operating input voltage .....                  | 8         |
| 6.2      | Output voltage adjustment .....                | 8         |
| 6.3      | Output voltage sense pin .....                 | 8         |
| 6.4      | Protection features .....                      | 8         |
| 6.5      | Enable pin .....                               | 9         |
| 6.6      | Input and output capacitors .....              | 9         |
| <b>7</b> | <b>Typical characteristics</b> .....           | <b>10</b> |
| <b>8</b> | <b>Package information</b> .....               | <b>16</b> |
| 8.1      | DFN6 (3x3) package information .....           | 16        |
| 8.2      | DFN6 (3x3) tape and reel mechanical data ..... | 17        |
| <b>9</b> | <b>Ordering information</b> .....              | <b>20</b> |
|          | <b>Revision history</b> .....                  | <b>21</b> |

## List of tables

|                 |                                                    |    |
|-----------------|----------------------------------------------------|----|
| <b>Table 1.</b> | Pin description (adjustable version) . . . . .     | 3  |
| <b>Table 2.</b> | Absolute maximum ratings . . . . .                 | 5  |
| <b>Table 3.</b> | Thermal data . . . . .                             | 5  |
| <b>Table 4.</b> | Electrical characteristics . . . . .               | 6  |
| <b>Table 5.</b> | DFN6 (3x3) mechanical data . . . . .               | 17 |
| <b>Table 6.</b> | DFN6 (3x3) tape and reel mechanical data . . . . . | 19 |
| <b>Table 7.</b> | Order code . . . . .                               | 20 |
| <b>Table 8.</b> | Document revision history . . . . .                | 21 |

## List of figures

|                   |                                                                                                                     |    |
|-------------------|---------------------------------------------------------------------------------------------------------------------|----|
| <b>Figure 1.</b>  | Block diagram, fixed version . . . . .                                                                              | 2  |
| <b>Figure 2.</b>  | Block diagram, adjustable version . . . . .                                                                         | 2  |
| <b>Figure 3.</b>  | Pin configuration (marking view) . . . . .                                                                          | 3  |
| <b>Figure 4.</b>  | Typical application diagram (fixed versions) . . . . .                                                              | 4  |
| <b>Figure 5.</b>  | Typical application diagram (adjustable versions) . . . . .                                                         | 4  |
| <b>Figure 6.</b>  | Output voltage vs. temperature ( $V_{IN} = 6\text{ V}$ , $V_{OUT} = \text{adjusted to } 5\text{ V}$ ) . . . . .     | 10 |
| <b>Figure 7.</b>  | Output voltage vs. temperature ( $V_{IN} = 13.2\text{ V}$ , $V_{OUT}$ adjusted to $5\text{ V}$ ) . . . . .          | 10 |
| <b>Figure 8.</b>  | Output voltage vs. temperature ( $V_{IN} = 18\text{ V}$ , $V_{OUT} = \text{adjusted to } 5\text{ V}$ ) . . . . .    | 10 |
| <b>Figure 9.</b>  | Output voltage vs. temperature ( $V_{IN} = 4.3\text{ V}$ , $V_{OUT} = 3.3\text{ V}$ ) . . . . .                     | 10 |
| <b>Figure 10.</b> | Output voltage vs. temperature ( $V_{IN} = 13.2\text{ V}$ , $V_{OUT} = 3.3\text{ V}$ ) . . . . .                    | 11 |
| <b>Figure 11.</b> | Output voltage vs. temperature ( $V_{IN} = 18\text{ V}$ , $V_{OUT} = 3.3\text{ V}$ ) . . . . .                      | 11 |
| <b>Figure 12.</b> | Reference voltage vs. temperature ( $V_{IN} = 6\text{ V}$ , $V_{OUT} = \text{adjusted to } 5\text{ V}$ ) . . . . .  | 11 |
| <b>Figure 13.</b> | Reference voltage vs. temperature ( $V_{IN} = 18\text{ V}$ , $V_{OUT} = \text{adjusted to } 5\text{ V}$ ) . . . . . | 11 |
| <b>Figure 14.</b> | Line regulation vs. temperature . . . . .                                                                           | 11 |
| <b>Figure 15.</b> | Load regulation vs. temperature . . . . .                                                                           | 11 |
| <b>Figure 16.</b> | Dropout voltage vs. temperature . . . . .                                                                           | 12 |
| <b>Figure 17.</b> | Short-circuit current vs. temperature . . . . .                                                                     | 12 |
| <b>Figure 18.</b> | Quiescent current vs. temperature . . . . .                                                                         | 12 |
| <b>Figure 19.</b> | Off-state current vs. temperature . . . . .                                                                         | 12 |
| <b>Figure 20.</b> | Enable thresholds vs. temperature . . . . .                                                                         | 12 |
| <b>Figure 21.</b> | Enable input current vs. temperature . . . . .                                                                      | 12 |
| <b>Figure 22.</b> | Output voltage vs. input voltage (no load) . . . . .                                                                | 13 |
| <b>Figure 23.</b> | Output voltage vs. input voltage ( $I_{OUT} = 1\text{ mA}$ ) . . . . .                                              | 13 |
| <b>Figure 24.</b> | Output voltage vs. input voltage ( $I_{OUT} = 100\text{ mA}$ ) . . . . .                                            | 13 |
| <b>Figure 25.</b> | Output voltage vs. input voltage ( $I_{OUT} = 400\text{ mA}$ ) . . . . .                                            | 13 |
| <b>Figure 26.</b> | Quiescent current vs. input voltage . . . . .                                                                       | 13 |
| <b>Figure 27.</b> | Stability plan . . . . .                                                                                            | 13 |
| <b>Figure 28.</b> | PSRR vs. frequency . . . . .                                                                                        | 14 |
| <b>Figure 29.</b> | Output noise spectrum . . . . .                                                                                     | 14 |
| <b>Figure 30.</b> | Line transient ( $t_r = t_f = 1\text{ }\mu\text{s}$ ) . . . . .                                                     | 14 |
| <b>Figure 31.</b> | Line transient ( $t_r = t_f = 10\text{ }\mu\text{s}$ ) . . . . .                                                    | 14 |
| <b>Figure 32.</b> | Load transient (0.1 mA to 100 mA, $t_r = t_f = 1\text{ }\mu\text{s}$ ) . . . . .                                    | 14 |
| <b>Figure 33.</b> | Load transient (0.1 mA to 100 mA, $t_r = t_f = 10\text{ }\mu\text{s}$ ) . . . . .                                   | 14 |
| <b>Figure 34.</b> | Load transient (1 mA to 400 mA, $t_r = t_f = 1\text{ }\mu\text{s}$ ) . . . . .                                      | 15 |
| <b>Figure 35.</b> | Load transient (1 mA to 400 mA, $t_r = t_f = 10\text{ }\mu\text{s}$ ) . . . . .                                     | 15 |
| <b>Figure 36.</b> | Enable transient ( $I_{OUT} = 0.1\text{ mA}$ ) . . . . .                                                            | 15 |
| <b>Figure 37.</b> | Enable transient ( $I_{OUT} = 400\text{ mA}$ ) . . . . .                                                            | 15 |
| <b>Figure 38.</b> | Start-up transient ( $I_{OUT} = 0.1\text{ mA}$ ) . . . . .                                                          | 15 |
| <b>Figure 39.</b> | Start-up transient ( $I_{OUT} = 400\text{ mA}$ ) . . . . .                                                          | 15 |
| <b>Figure 40.</b> | DFN6 (3x3) package outline . . . . .                                                                                | 16 |
| <b>Figure 41.</b> | DFN6 (3x3) recommended footprint (dimensions are in mm) . . . . .                                                   | 17 |
| <b>Figure 42.</b> | DFN6 (3x3) tape outline . . . . .                                                                                   | 18 |
| <b>Figure 43.</b> | DFN6 (3x3) reel outline . . . . .                                                                                   | 19 |



**IMPORTANT NOTICE – PLEASE READ CAREFULLY**

STMicroelectronics NV and its subsidiaries (“ST”) reserve the right to make changes, corrections, enhancements, modifications, and improvements to ST products and/or to this document at any time without notice. Purchasers should obtain the latest relevant information on ST products before placing orders. ST products are sold pursuant to ST’s terms and conditions of sale in place at the time of order acknowledgement.

Purchasers are solely responsible for the choice, selection, and use of ST products and ST assumes no liability for application assistance or the design of Purchasers’ products.

No license, express or implied, to any intellectual property right is granted by ST herein.

Resale of ST products with provisions different from the information set forth herein shall void any warranty granted by ST for such product.

ST and the ST logo are trademarks of ST. All other product or service names are the property of their respective owners.

Information in this document supersedes and replaces information previously supplied in any prior versions of this document.

© 2018 STMicroelectronics – All rights reserved

Компания «Океан Электроники» предлагает заключение долгосрочных отношений при поставках импортных электронных компонентов на взаимовыгодных условиях!

Наши преимущества:

- Поставка оригинальных импортных электронных компонентов напрямую с производств Америки, Европы и Азии, а так же с крупнейших складов мира;
- Широкая линейка поставок активных и пассивных импортных электронных компонентов (более 30 млн. наименований);
- Поставка сложных, дефицитных, либо снятых с производства позиций;
- Оперативные сроки поставки под заказ (от 5 рабочих дней);
- Экспресс доставка в любую точку России;
- Помощь Конструкторского Отдела и консультации квалифицированных инженеров;
- Техническая поддержка проекта, помощь в подборе аналогов, поставка прототипов;
- Поставка электронных компонентов под контролем ВП;
- Система менеджмента качества сертифицирована по Международному стандарту ISO 9001;
- При необходимости вся продукция военного и аэрокосмического назначения проходит испытания и сертификацию в лаборатории (по согласованию с заказчиком);
- Поставка специализированных компонентов военного и аэрокосмического уровня качества (Xilinx, Altera, Analog Devices, Intersil, Interpoint, Microsemi, Actel, Aeroflex, Peregrine, VPT, Syfer, Eurofarad, Texas Instruments, MS Kennedy, Miteq, Cobham, E2V, MA-COM, Hittite, Mini-Circuits, General Dynamics и др.);

Компания «Океан Электроники» является официальным дистрибьютором и эксклюзивным представителем в России одного из крупнейших производителей разъемов военного и аэрокосмического назначения «JONHON», а так же официальным дистрибьютором и эксклюзивным представителем в России производителя высокотехнологичных и надежных решений для передачи СВЧ сигналов «FORSTAR».



## JONHON

«JONHON» (основан в 1970 г.)

Разъемы специального, военного и аэрокосмического назначения:

(Применяются в военной, авиационной, аэрокосмической, морской, железнодорожной, горно- и нефтедобывающей отраслях промышленности)

«FORSTAR» (основан в 1998 г.)

ВЧ соединители, коаксиальные кабели, кабельные сборки и микроволновые компоненты:

(Применяются в телекоммуникациях гражданского и специального назначения, в средствах связи, РЛС, а так же военной, авиационной и аэрокосмической отраслях промышленности).



Телефон: 8 (812) 309-75-97 (многоканальный)

Факс: 8 (812) 320-03-32

Электронная почта: [ocean@oceanchips.ru](mailto:ocean@oceanchips.ru)

Web: <http://oceanchips.ru/>

Адрес: 198099, г. Санкт-Петербург, ул. Калинина, д. 2, корп. 4, лит. А