

Arm[®]-Cortex[®]-M4 32b MCU+FPU, 125 DMIPS, up to 1.5MB Flash, 320KB RAM, USB OTG FS, 1 ADC, 2 DACs, 2 DFSDMs

Datasheet - production data

Features

- Dynamic Efficiency Line with eBAM (enhanced Batch Acquisition Mode)
 - 1.7 V to 3.6 V power supply
 - -40 °C to 85/105/125 °C temperature range
- Core: Arm[®] 32-bit Cortex[®]-M4 CPU with FPU, Adaptive real-time accelerator (ART Accelerator™) allowing 0-wait state execution from Flash memory, frequency up to 100 MHz, memory protection unit, 125 DMIPS/1.25 DMIPS/MHz (Dhrystone 2.1), and DSP instructions
- Memories
 - Up to 1.5 Mbytes of Flash memory
 - 320 Kbytes of SRAM
 - Flexible external static memory controller with up to 16-bit data bus: SRAM, PSRAM, NOR Flash memory
 - Dual mode Quad-SPI interface
- LCD parallel interface, 8080/6800 modes
- Clock, reset and supply management
 - 1.7 to 3.6 V application supply and I/Os
 - POR, PDR, PVD and BOR
 - 4-to-26 MHz crystal oscillator
 - Internal 16 MHz factory-trimmed RC
 - 32 kHz oscillator for RTC with calibration
 - Internal 32 kHz RC with calibration
- Power consumption
 - Run: 112 µA/MHz (peripheral off)
 - Stop (Flash in Stop mode, fast wakeup time): 42 µA Typ.; 80 µA max @25 °C
 - Stop (Flash in Deep power down mode, slow wakeup time): 15 µA Typ.; 46 µA max @25 °C
 - Standby without RTC: 1.1 µA Typ.; 14.7 µA max at @85 °C
 - V_{BAT} supply for RTC: 1 µA @25 °C
- 2x12-bit D/A converters
- 1x12-bit, 2.4 MSPS ADC: up to 16 channels
- 6x digital filters for sigma delta modulator, 12x PDM interfaces, with stereo microphone and sound source localization support
- General-purpose DMA: 16-stream DMA

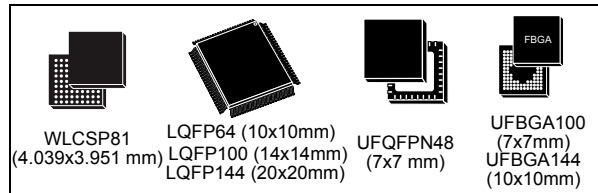

- Up to 18 timers: up to twelve 16-bit timers, two 32-bit timers up to 100 MHz each with up to four IC/OC/PWM or pulse counter and quadrature (incremental) encoder input, two watchdog timers (independent and window), one SysTick timer, and a low-power timer
- Debug mode
 - Serial wire debug (SWD) & JTAG
 - Cortex[®]-M4 Embedded Trace Macrocell™
- Up to 114 I/O ports with interrupt capability
 - Up to 109 fast I/Os up to 100 MHz
 - Up to 114 five V-tolerant I/Os
- Up to 24 communication interfaces
 - Up to 4x I²C interfaces (SMBus/PMBus)
 - Up to 10 UARTS: 4 USARTs / 6 UARTS (2 x 12.5 Mbit/s, 2 x 6.25 Mbit/s), ISO 7816 interface, LIN, IrDA, modem control)
 - Up to 5 SPI/I2Ss (up to 50 Mbit/s, SPI or I2S audio protocol), out of which 2 muxed full-duplex I2S interfaces
 - SDIO interface (SD/MMC/eMMC)
 - Advanced connectivity: USB 2.0 full-speed device/host/OTG controller with PHY
 - 3x CAN (2.0B Active)
 - 1xSAI
- True random number generator
- CRC calculation unit
- 96-bit unique ID
- RTC: subsecond accuracy, hardware calendar
- All packages are ECOPACK[®]2

Table 1. Device summary

Reference	Part number
STM32F413xH	STM32F413CH STM32F413MH STM32F413RH STM32F413VH STM32F413ZH
STM32F413xG	STM32F413CG STM32F413MG STM32F413RG STM32F413VG STM32F413ZG

Contents

- 1 Introduction 12**
- 2 Description 13**
 - 2.1 Compatibility with STM32F4 series 16
- 3 Functional overview 19**
 - 3.1 Arm[®] Cortex[®]-M4 with FPU core with embedded Flash and SRAM 19
 - 3.2 Adaptive real-time memory accelerator (ART Accelerator[™]) 19
 - 3.3 Enhanced Batch Acquisition mode (eBAM) 19
 - 3.4 Memory protection unit 20
 - 3.5 Embedded Flash memory 20
 - 3.6 CRC (cyclic redundancy check) calculation unit 20
 - 3.7 Embedded SRAM 21
 - 3.8 Multi-AHB bus matrix 21
 - 3.9 DMA controller (DMA) 22
 - 3.10 Flexible static memory controller (FSMC) 22
 - 3.11 Quad-SPI memory interface (QUAD-SPI) 23
 - 3.12 Nested vectored interrupt controller (NVIC) 23
 - 3.13 External interrupt/event controller (EXTI) 23
 - 3.14 Clocks and startup 23
 - 3.15 Boot modes 24
 - 3.16 Power supply schemes 25
 - 3.17 Power supply supervisor 26
 - 3.17.1 Internal reset ON 26
 - 3.17.2 Internal reset OFF 27
 - 3.18 Voltage regulator 27
 - 3.18.1 Regulator ON 28
 - 3.18.2 Regulator OFF 28
 - 3.18.3 Regulator ON/OFF and internal reset ON/OFF availability 31
 - 3.19 Real-time clock (RTC) and backup registers 31
 - 3.20 Low-power modes 32
 - 3.21 VBAT operation 32

3.22	Timers and watchdogs	33
3.22.1	Advanced-control timers (TIM1, TIM8)	34
3.22.2	General-purpose timers (TIMx)	34
3.22.3	Basic timer (TIM6, TIM7)	35
3.22.4	Low-power timer (LPTIM1)	35
3.22.5	Independent watchdog	35
3.22.6	Window watchdog	36
3.22.7	SysTick timer	36
3.23	Inter-integrated circuit interface (I2C)	36
3.24	Universal synchronous/asynchronous receiver transmitters (USART)	36
3.25	Serial peripheral interface (SPI)	38
3.26	Inter-integrated sound (I ² S)	38
3.27	Serial Audio interface (SAI1)	38
3.28	Audio PLL (PLLI2S)	38
3.29	Digital filter for sigma-delta modulators (DFSDM)	39
3.30	Dynamic tuning of PDM delays for sound source localization	39
3.31	Secure digital input/output interface (SDIO)	40
3.32	Controller area network (bxCAN)	40
3.33	Universal serial bus on-the-go full-speed (USB_OTG_FS)	40
3.34	Random number generator (RNG)	41
3.35	General-purpose input/outputs (GPIOs)	41
3.36	Analog-to-digital converter (ADC)	41
3.37	Digital to analog converter (DAC)	41
3.38	Temperature sensor	42
3.39	Serial wire JTAG debug port (SWJ-DP)	42
3.40	Embedded Trace Macrocell™	42
4	Pinouts and pin description	43
4.1	WLCSP81 pinout description	43
4.2	UFQFPN48 pinout description	44
4.3	LQFP64 pinout description	45
4.4	LQFP100 pinout description	46
4.5	LQFP144 pinout description	47
4.6	UFBGA100 pinout description	48

4.7	UFBGA144 pinout description	49
4.8	Pins definition	49
4.9	Alternate functions	67
5	Memory mapping	74
6	Electrical characteristics	78
6.1	Parameter conditions	78
6.1.1	Minimum and maximum values	78
6.1.2	Typical values	78
6.1.3	Typical curves	78
6.1.4	Loading capacitor	78
6.1.5	Pin input voltage	78
6.1.6	Power supply scheme	79
6.1.7	Current consumption measurement	80
6.2	Absolute maximum ratings	80
6.3	Operating conditions	82
6.3.1	General operating conditions	82
6.3.2	VCAP_1/VCAP_2 external capacitors	85
6.3.3	Operating conditions at power-up/power-down (regulator ON)	85
6.3.4	Operating conditions at power-up / power-down (regulator OFF)	86
6.3.5	Embedded reset and power control block characteristics	86
6.3.6	Supply current characteristics	87
6.3.7	Wakeup time from low-power modes	105
6.3.8	External clock source characteristics	107
6.3.9	Internal clock source characteristics	112
6.3.10	PLL characteristics	114
6.3.11	PLL spread spectrum clock generation (SSCG) characteristics	116
6.3.12	Memory characteristics	117
6.3.13	EMC characteristics	120
6.3.14	Absolute maximum ratings (electrical sensitivity)	121
6.3.15	I/O current injection characteristics	122
6.3.16	I/O port characteristics	123
6.3.17	NRST pin characteristics	128
6.3.18	TIM timer characteristics	129
6.3.19	Communications interfaces	130
6.3.20	12-bit ADC characteristics	144

6.3.21	Temperature sensor characteristics	150
6.3.22	V _{BAT} monitoring characteristics	151
6.3.23	Embedded reference voltage	151
6.3.24	DAC electrical characteristics	152
6.3.25	DFSDM characteristics	155
6.3.26	FSMC characteristics	158
6.3.27	SD/SDIO MMC/eMMC card host interface (SDIO) characteristics	172
6.3.28	RTC characteristics	174
7	Package information	175
7.1	WLCSP81 package information	175
7.2	UFQFPN48 package information	179
7.3	LQFP64 package information	182
7.4	LQFP100 package information	186
7.5	LQFP144 package information	189
7.6	UFBGA100 package information	193
7.7	UFBGA144 package information	196
7.8	Thermal characteristics	199
7.8.1	Reference document	199
8	Ordering information	200
Appendix A Recommendations when using the internal reset OFF		201
Appendix B Application block diagrams		202
B.1	Sensor Hub application example	202
B.2	Display application example	203
B.3	USB OTG full speed (FS) interface solutions	204
Revision history		206

List of tables

Table 1.	Device summary	1
Table 2.	STM32F413xG/H features and peripheral counts	15
Table 3.	Embedded bootloader interfaces	24
Table 4.	Regulator ON/OFF and internal power supply supervisor availability.	31
Table 5.	Timer feature comparison.	33
Table 6.	Comparison of I2C analog and digital filters.	36
Table 7.	USART feature comparison	37
Table 8.	DFSDM feature comparison	39
Table 9.	Legend/abbreviations used in the pinout table	49
Table 10.	STM32F413xG/H pin definition.	50
Table 11.	FSMC pin definition	64
Table 12.	STM32F413xG/H alternate functions	67
Table 13.	STM32F413xG/H register boundary addresses	75
Table 14.	Voltage characteristics	80
Table 15.	Current characteristics	81
Table 16.	Thermal characteristics.	81
Table 17.	General operating conditions	82
Table 18.	Features depending on the operating power supply range	84
Table 19.	VCAP_1/VCAP_2 operating conditions	85
Table 20.	Operating conditions at power-up / power-down (regulator ON)	85
Table 21.	Operating conditions at power-up / power-down (regulator OFF).	86
Table 22.	Embedded reset and power control block characteristics.	86
Table 23.	Typical and maximum current consumption, code with data processing (ART accelerator disabled) running from SRAM - $V_{DD} = 1.7\text{ V}$	88
Table 24.	Typical and maximum current consumption, code with data processing (ART accelerator disabled) running from SRAM - $V_{DD} = 3.6\text{ V}$	89
Table 25.	Typical and maximum current consumption in run mode, code with data processing (ART accelerator enabled except prefetch) running from Flash memory- $V_{DD} = 1.7\text{ V}$	90
Table 26.	Typical and maximum current consumption in run mode, code with data processing (ART accelerator enabled except prefetch) running from Flash memory - $V_{DD} = 3.6\text{ V}$	91
Table 27.	Typical and maximum current consumption in run mode, code with data processing (ART accelerator disabled) running from Flash memory - $V_{DD} = 3.6\text{ V}$	92
Table 28.	Typical and maximum current consumption in run mode, code with data processing (ART accelerator disabled) running from Flash memory - $V_{DD} = 1.7\text{ V}$	93
Table 29.	Typical and maximum current consumption in run mode, code with data processing (ART accelerator enabled with prefetch) running from Flash memory - $V_{DD} = 3.6\text{ V}$	94
Table 30.	Typical and maximum current consumption in run mode, code with data processing (ART accelerator enabled with prefetch) running from Flash memory - $V_{DD} = 1.7\text{ V}$	95
Table 31.	Typical and maximum current consumption in Sleep mode - $V_{DD} = 3.6\text{ V}$	96
Table 32.	Typical and maximum current consumption in Sleep mode - $V_{DD} = 1.7\text{ V}$	97
Table 33.	Typical and maximum current consumptions in Stop mode - $V_{DD} = 1.7\text{ V}$	98
Table 34.	Typical and maximum current consumption in Stop mode - $V_{DD}=3.6\text{ V}$	98
Table 35.	Typical and maximum current consumption in Standby mode - $V_{DD}= 1.7\text{ V}$	98
Table 36.	Typical and maximum current consumption in Standby mode - $V_{DD}= 3.6\text{ V}$	99
Table 37.	Typical and maximum current consumptions in V_{BAT} mode.	99
Table 38.	Switching output I/O current consumption	102
Table 39.	Peripheral current consumption	103
Table 40.	Low-power mode wakeup timings	107

Table 41.	High-speed external user clock characteristics	108
Table 42.	Low-speed external user clock characteristics	108
Table 43.	HSE 4-26 MHz oscillator characteristics	110
Table 44.	LSE oscillator characteristics ($f_{LSE} = 32.768$ kHz)	111
Table 45.	HSI oscillator characteristics	112
Table 46.	LSI oscillator characteristics	113
Table 47.	Main PLL characteristics	114
Table 48.	PLL12S (audio PLL) characteristics	115
Table 49.	SSCG parameter constraints	116
Table 50.	Flash memory characteristics	117
Table 51.	Flash memory programming	118
Table 52.	Flash memory programming with V_{PP} voltage	119
Table 53.	Flash memory endurance and data retention	119
Table 54.	EMS characteristics for LQFP144 package	120
Table 55.	EMI characteristics for LQFP144	121
Table 56.	ESD absolute maximum ratings	122
Table 57.	Electrical sensitivities	122
Table 58.	I/O current injection susceptibility	123
Table 59.	I/O static characteristics	123
Table 60.	Output voltage characteristics	126
Table 61.	I/O AC characteristics	127
Table 62.	NRST pin characteristics	128
Table 63.	TIMx characteristics	129
Table 64.	I ² C characteristics	130
Table 65.	SCL frequency ($f_{PCLK1} = 50$ MHz, $V_{DD} = V_{DD_I2C} = 3.3$ V)	131
Table 66.	FMPI ² C characteristics	132
Table 67.	SPI dynamic characteristics	134
Table 68.	I ² S dynamic characteristics	137
Table 69.	SAI characteristics	139
Table 70.	QSPI dynamic characteristics in SDR mode	141
Table 71.	QSPI dynamic characteristics in DDR mode	141
Table 72.	USB OTG FS startup time	142
Table 73.	USB OTG FS DC electrical characteristics	142
Table 74.	USB OTG FS electrical characteristics	143
Table 75.	ADC characteristics	144
Table 76.	ADC accuracy at $f_{ADC} = 18$ MHz	145
Table 77.	ADC accuracy at $f_{ADC} = 30$ MHz	146
Table 78.	ADC accuracy at $f_{ADC} = 36$ MHz	146
Table 79.	ADC dynamic accuracy at $f_{ADC} = 18$ MHz - limited test conditions	146
Table 80.	ADC dynamic accuracy at $f_{ADC} = 36$ MHz - limited test conditions	146
Table 81.	Temperature sensor characteristics	150
Table 82.	Temperature sensor calibration values	150
Table 83.	V_{BAT} monitoring characteristics	151
Table 84.	Embedded internal reference voltage	151
Table 85.	Internal reference voltage calibration values	151
Table 86.	DAC characteristics	152
Table 87.	DFSDM characteristics	155
Table 88.	Asynchronous non-multiplexed SRAM/PSRAM/NOR - read timings	160
Table 89.	Asynchronous non-multiplexed SRAM/PSRAM/NOR read - NWAIT timings	160
Table 90.	Asynchronous non-multiplexed SRAM/PSRAM/NOR write timings	161

Table 91.	Asynchronous non-multiplexed SRAM/PSRAM/NOR write - NWAIT timings	162
Table 92.	Asynchronous multiplexed PSRAM/NOR read timings	163
Table 93.	Asynchronous multiplexed PSRAM/NOR read-NWAIT timings	163
Table 94.	Asynchronous multiplexed PSRAM/NOR write timings	165
Table 95.	Asynchronous multiplexed PSRAM/NOR write-NWAIT timings	165
Table 96.	Synchronous multiplexed NOR/PSRAM read timings	167
Table 97.	Synchronous multiplexed PSRAM write timings	169
Table 98.	Synchronous non-multiplexed NOR/PSRAM read timings	170
Table 99.	Synchronous non-multiplexed PSRAM write timings	171
Table 100.	SD / MMC characteristics	173
Table 101.	eMMC characteristics VDD = 1.7 V to 1.9 V	173
Table 102.	RTC characteristics	174
Table 103.	WLCSP81 - 81-ball, 4.039 x 3.951 mm, 0.4 mm pitch wafer level chip scale package mechanical data	176
Table 104.	WLCSP81 recommended PCB design rules (0.4 mm pitch)	177
Table 105.	UFQFPN48 - 48-lead, 7x7 mm, 0.5 mm pitch, ultra thin fine pitch quad flat package mechanical data	180
Table 106.	LQFP64 - 64-pin, 10 x 10 mm low-profile quad flat package mechanical data	183
Table 107.	LQPF100 - 100-pin, 14 x 14 mm low-profile quad flat package mechanical data	186
Table 108.	LQFP144 - 144-pin, 20 x 20 mm low-profile quad flat package mechanical data	190
Table 109.	UFBGA100 - 100-ball, 7 x 7 mm, 0.50 mm pitch, ultra fine pitch ball grid array package mechanical data	193
Table 110.	UFBGA100 recommended PCB design rules (0.5 mm pitch BGA)	194
Table 111.	UFBGA144 - 144-ball, 10 x 10 mm, 0.80 mm pitch, ultra fine pitch ball grid array package mechanical data	196
Table 112.	UFBGA144 recommended PCB design rules (0.80 mm pitch BGA)	197
Table 113.	Package thermal characteristics	199
Table 114.	Ordering information scheme	200
Table 115.	Document revision history	206

List of figures

Figure 1.	Compatible board design for LQFP100 package	16
Figure 2.	Compatible board design for LQFP64 package	17
Figure 3.	Compatible board design for LQFP144 package	17
Figure 4.	STM32F413xG/H block diagram	18
Figure 5.	Multi-AHB matrix	21
Figure 6.	VDDUSB connected to an external independent power supply	26
Figure 7.	Power supply supervisor interconnection with internal reset OFF	27
Figure 8.	Regulator OFF	29
Figure 9.	Startup in regulator OFF: slow V_{DD} slope power-down reset risen after V_{CAP_1}/V_{CAP_2} stabilization	30
Figure 10.	Startup in regulator OFF mode: fast V_{DD} slope power-down reset risen before V_{CAP_1}/V_{CAP_2} stabilization	30
Figure 11.	STM32F413xG/H WLCSP81 pinout	43
Figure 12.	STM32F413xG/H UFQFPN48 pinout	44
Figure 13.	STM32F413xG/H LQFP64 pinout	45
Figure 14.	STM32F413xG/H LQFP100 pinout	46
Figure 15.	STM32F413xG/H LQFP144 pinout	47
Figure 16.	STM32F413xG/H UFBGA100 pinout	48
Figure 17.	STM32F413xG/H UFBGA144 pinout	49
Figure 18.	Memory map	74
Figure 19.	Pin loading conditions	78
Figure 20.	Input voltage measurement	78
Figure 21.	Power supply scheme	79
Figure 22.	Current consumption measurement scheme	80
Figure 23.	External capacitor C_{EXT}	85
Figure 24.	Typical V_{BAT} current consumption (LSE and RTC ON/LSE oscillator “low power” mode selection)	100
Figure 25.	Typical V_{BAT} current consumption (LSE and RTC ON/LSE oscillator “high drive” mode selection)	100
Figure 26.	Low-power mode wakeup	106
Figure 27.	High-speed external clock source AC timing diagram	109
Figure 28.	Low-speed external clock source AC timing diagram	109
Figure 29.	Typical application with an 8 MHz crystal	110
Figure 30.	Typical application with a 32.768 kHz crystal	111
Figure 31.	ACC_{HSI} versus temperature	112
Figure 32.	ACC_{LSI} versus temperature	113
Figure 33.	PLL output clock waveforms in center spread mode	117
Figure 34.	PLL output clock waveforms in down spread mode	117
Figure 35.	FT/TC I/O input characteristics	125
Figure 36.	I/O AC characteristics definition	128
Figure 37.	Recommended NRST pin protection	129
Figure 38.	I ² C bus AC waveforms and measurement circuit	131
Figure 39.	FMPI ² C timing diagram and measurement circuit	133
Figure 40.	SPI timing diagram - slave mode and CPHA = 0	135
Figure 41.	SPI timing diagram - slave mode and CPHA = 1	136
Figure 42.	SPI timing diagram - master mode	136
Figure 43.	I ² S slave timing diagram (Philips protocol)	138
Figure 44.	I ² S master timing diagram (Philips protocol)	138

Figure 45.	SAI master timing waveforms	140
Figure 46.	SAI slave timing waveforms	140
Figure 47.	USB OTG FS timings: definition of data signal rise and fall time	143
Figure 48.	ADC accuracy characteristics	147
Figure 49.	Typical connection diagram using the ADC	148
Figure 50.	Power supply and reference decoupling (V_{REF+} not connected to V_{DDA})	149
Figure 51.	Power supply and reference decoupling (V_{REF+} connected to V_{DDA})	150
Figure 52.	12-bit buffered /non-buffered DAC	154
Figure 53.	Asynchronous non-multiplexed SRAM/PSRAM/NOR read waveforms	159
Figure 54.	Asynchronous non-multiplexed SRAM/PSRAM/NOR write waveforms	161
Figure 55.	Asynchronous multiplexed PSRAM/NOR read waveforms	162
Figure 56.	Asynchronous multiplexed PSRAM/NOR write waveforms	164
Figure 57.	Synchronous multiplexed NOR/PSRAM read timings	166
Figure 58.	Synchronous multiplexed PSRAM write timings	168
Figure 59.	Synchronous non-multiplexed NOR/PSRAM read timings	170
Figure 60.	Synchronous non-multiplexed PSRAM write timings	171
Figure 61.	SDIO high-speed mode	172
Figure 62.	SD default mode	172
Figure 63.	WLCSP81 - 81-ball, 4.039 x 3.951 mm, 0.4 mm pitch wafer level chip scale package outline	175
Figure 64.	WLCSP81- 81-ball, 4.039 x 3.951 mm, 0.4 mm pitch wafer level chip scale package recommended footprint	177
Figure 65.	WLCSP81 marking example (package top view)	178
Figure 66.	UFQFPN48 - 48-lead, 7x7 mm, 0.5 mm pitch, ultra thin fine pitch quad flat package outline	179
Figure 67.	UFQFPN48 recommended footprint	180
Figure 68.	UFQFPN48 marking example (package top view)	181
Figure 69.	LQFP64 - 64-pin, 10 x 10 mm low-profile quad flat package outline	182
Figure 70.	LQFP64 recommended footprint	184
Figure 71.	LQFP64 marking example (package top view)	185
Figure 72.	LQFP100 - 100-pin, 14 x 14 mm low-profile quad flat package outline	186
Figure 73.	LQFP100 - 100-pin, 14 x 14 mm low-profile quad flat recommended footprint	187
Figure 74.	LQFP100 marking example (package top view)	188
Figure 75.	LQFP144 - 144-pin, 20 x 20 mm low-profile quad flat package outline	189
Figure 76.	LQFP144 - 144-pin, 20 x 20 mm low-profile quad flat package recommended footprint	191
Figure 77.	LQFP144 marking example (package top view)	192
Figure 78.	UFBGA100 - 100-pin, 7 x 7 mm, 0.50 mm pitch, ultra fine pitch ball grid array package outline	193
Figure 79.	UFBGA100 - 100-pin, 7 x 7 mm, 0.50 mm pitch, ultra fine pitch ball grid array package recommended footprint	194
Figure 80.	UFBGA100 marking example (package top view)	195
Figure 81.	UFBGA144 - 144-pin, 10 x 10 mm, 0.80 mm pitch, ultra fine pitch ball grid array package outline	196
Figure 82.	UFBGA144 - 144-pin, 10 x 10 mm, 0.80 mm pitch, ultra fine pitch ball grid array recommended footprint	197
Figure 83.	UFBGA144 marking example (package top view)	198
Figure 84.	Sensor Hub application example	202
Figure 85.	Display application example	203
Figure 86.	USB controller configured as peripheral-only and used in Full speed mode	204
Figure 87.	USB peripheral-only Full speed mode with direct connection	

	for VBUS sense	204
Figure 88.	USB peripheral-only Full speed mode, VBUS detection using GPIO	205
Figure 89.	USB controller configured as host-only and used in full speed mode	205

1 Introduction

This datasheet provides the description of the STM32F413xG/H microcontrollers.

For information on the Cortex[®]-M4 core, please refer to the Cortex[®]-M4 programming manual (PM0214) available from www.st.com.



2 Description

The STM32F413xG/H devices are based on the high-performance Arm® Cortex®-M4 32-bit RISC core operating at a frequency of up to 100 MHz. Their Cortex®-M4 core features a Floating point unit (FPU) single precision which supports all Arm single-precision data-processing instructions and data types. It also implements a full set of DSP instructions and a memory protection unit (MPU) which enhances application security.

The STM32F413xG/H devices belong to the STM32F4 access product lines (with products combining power efficiency, performance and integration) while adding a new innovative feature called Batch Acquisition Mode (BAM) allowing to save even more power consumption during data batching.

The STM32F413xG/H devices incorporate high-speed embedded memories (up to 1.5 Mbytes of Flash memory, 320 Kbytes of SRAM), and an extensive range of enhanced I/Os and peripherals connected to two APB buses, three AHB buses and a 32-bit multi-AHB bus matrix.

All devices offer a 12-bit ADC, two 12-bit DACs, a low-power RTC, twelve general-purpose 16-bit timers including two PWM timer for motor control, two general-purpose 32-bit timers and a low power timer.

They also feature standard and advanced communication interfaces.

- Up to four I²Cs, including one I²C supporting Fast-Mode Plus
- Five SPIs
- Five I²Ss out of which two are full duplex. To achieve audio class accuracy, the I²S peripherals can be clocked via a dedicate internal audio PLL or via an external clock to allow synchronization.
- Four USARTs and six UARTs
- An SDIO/MMC interface
- An USB 2.0 OTG full-speed interface
- Three CANs
- An SAI.

In addition, the STM32F413xG/H devices embed advanced peripherals:

- A flexible static memory control interface (FSMC)
- A Quad-SPI memory interface
- Two digital filter for sigma modulator (DFSDM) supporting microphone MEMs and sound source localization, one with two filters and up to four inputs, and the second one with four filters and up to eight inputs

They are offered in 7 packages ranging from 48 to 144 pins. The set of available peripherals depends on the selected package. The STM32F413xG/H operate in the – 40 to + 125 °C temperature range from a 1.7 (PDR OFF) to 3.6 V power supply. A comprehensive set of power-saving mode allows the design of low-power applications.

These features make the STM32F413xG/H microcontrollers suitable for a wide range of applications:

- Motor drive and application control
- Medical equipment
- Industrial applications: PLC, inverters, circuit breakers
- Printers, and scanners
- Alarm systems, video intercom, and HVAC
- Home audio appliances
- Mobile phone sensor hub
- Wearable devices
- Connected objects
- Wifi modules

Table 2. STM32F413xG/H features and peripheral counts

Peripherals		STM32F413xG					STM32F413xH				
Flash memory (Kbyte)		1024					1536				
SRAM (Kbyte)	System	320 (256 + 64)					320 (256 + 64)				
Quad-SPI memory interface		-	1				-	1			
FSMC memory controller		-	1 ⁽¹⁾	1 ⁽¹⁾	1 ⁽¹⁾	1	-	1 ⁽¹⁾	1 ⁽¹⁾	1 ⁽¹⁾	1
FSMC LCD parallel interface Data bus size		-	8	16			-	8	16		
Timers	General-purpose	10 ⁽²⁾	10	10 ⁽³⁾	10		10 ⁽²⁾	10	10 ⁽³⁾	10	
	Advanced-control	2 ⁽⁴⁾	2				2 ⁽⁴⁾	2			
	Basic	2					2				
	Low-power timer	1					1				
Random number generator		1					1				
Comm. interfaces	SPI/ I ² S	5/5 (2 full duplex)					5/5 (2 full duplex)				
	I ² C	3					3				
	I ² C FMP	1					1				
	USART/ UART	3/3	4/3		4/6		3/3	4/3		4/6	
	SDIO/MMC	1					1				
	USB/OTG FS Dual power rail	1 No	1 Yes	1 No	1 Yes		1 No	1 Yes	1 No	1 Yes	
	CAN	3					3				
	SAI	1					1				
Number of digital Filters for Sigma-delta modulator		6					6				
Number of channels		7	11	12			7	11	12		
GPIOs		36	50	60	81	114	36	50	60	81	114
12-bit ADC		1					1				
Number of channels		10	16				10	16			
12-bit DAC		Yes					Yes				
Number of channels		2					2				
Maximum CPU frequency		100 MHz					100 MHz				
Operating voltage		1.7 to 3.6 V					1.7 to 3.6 V				
Operating temperatures		Ambient temperatures: - 40 to +85 °C / - 40 to +105 °C / - 40 to +125 °C					Ambient temperatures: - 40 to +85 °C / - 40 to +105 °C / - 40 to +125 °C				
		Junction temperature: -40 to + 130 °C					Junction temperature: -40 to + 130 °C				
Package		UFQFPN 48	LQFP 64	WLCSP 81	UFBGA/ LQFP100	UFBGA/ LQFP144	UFQFPN 48	LQFP64	WLCSP 81	UFBGA/ LQFP100	UFBGA/ LQFP144

- 64 pins package: support only 8 bits multiplexed mode interface
81 pins package: support 1 external memory of up to 64KB in multiplexed mode
100 pins: support 2 external memories of up to 64MB in multiplexed mode
Refer to [Table 11: FSMC pin definition](#) for more detailed information
- 48 pins packages: TIM3 and TIM4: ETR pin not available.
- 81 pins packages: TIM4: ETR pin not available.
- 48 pins packages: TIM8:CH1, CH2, CH3 and CH4 pins not available.



2.1 Compatibility with STM32F4 series

The STM32F413xG/H are fully software and feature compatible with the STM32F4 series (STM32F42x, STM32F401, STM32F43x, STM32F41x, STM32F405 and STM32F407)

The STM32F413xG/H can be used as drop-in replacement of the other STM32F4 products but some slight changes have to be done on the PCB board.

Figure 1. Compatible board design for LQFP100 package

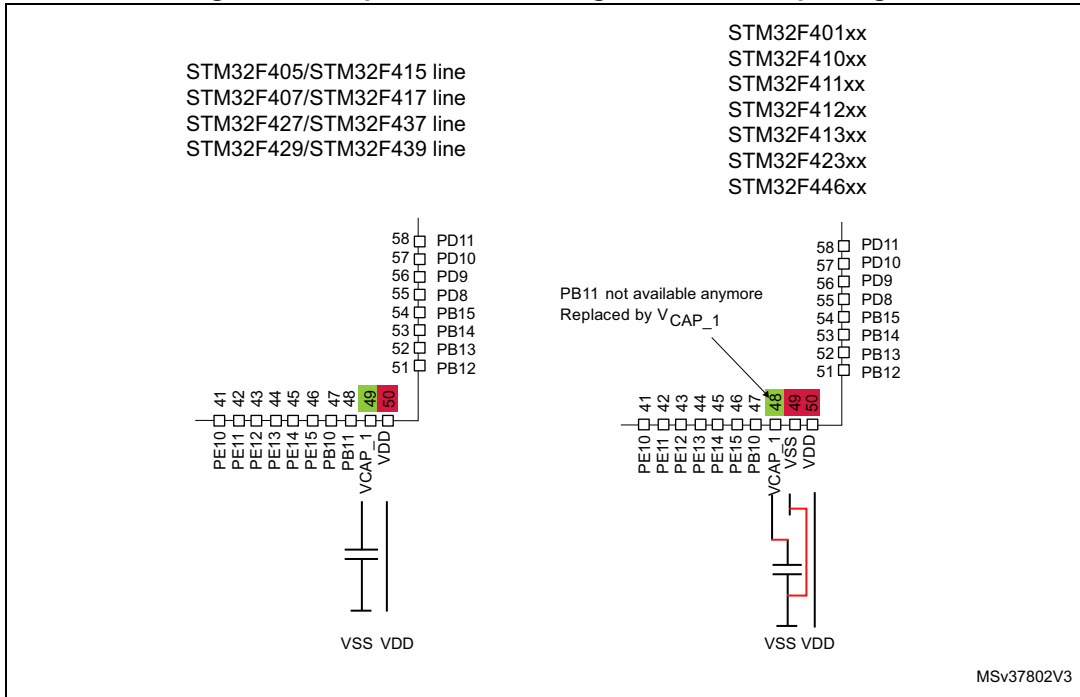

Figure 2. Compatible board design for LQFP64 package

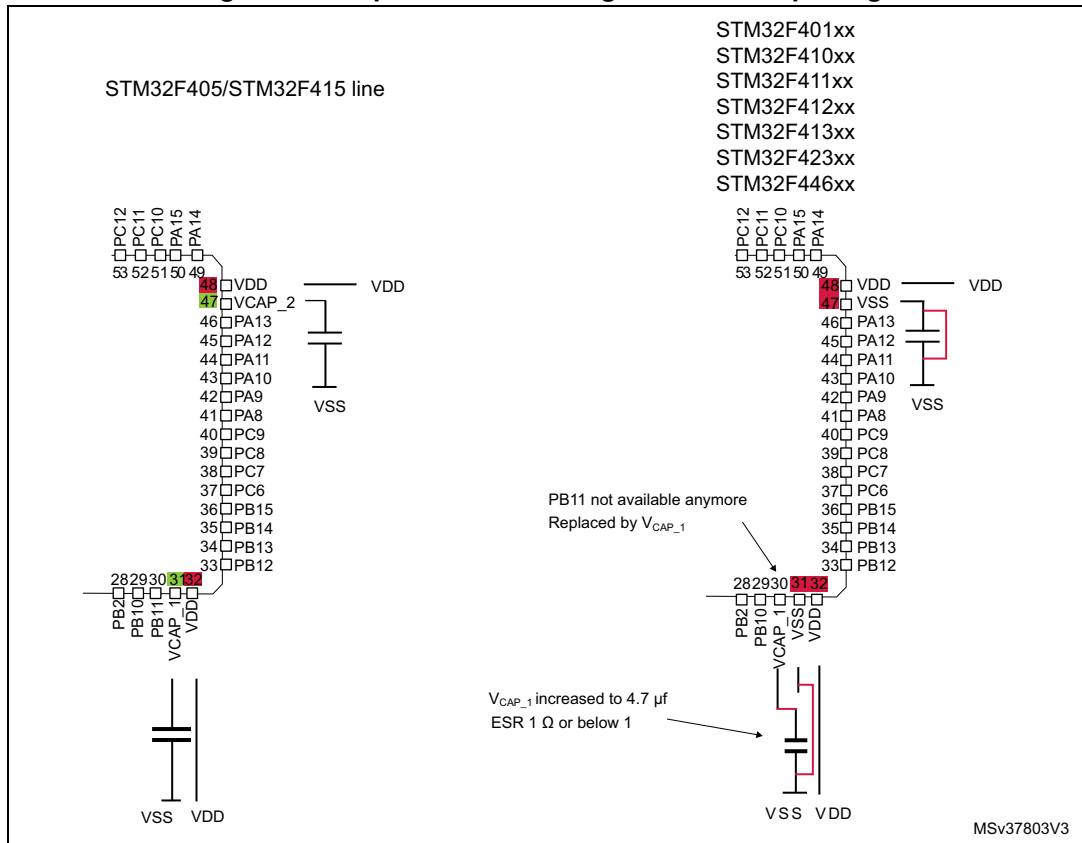

Figure 3. Compatible board design for LQFP144 package

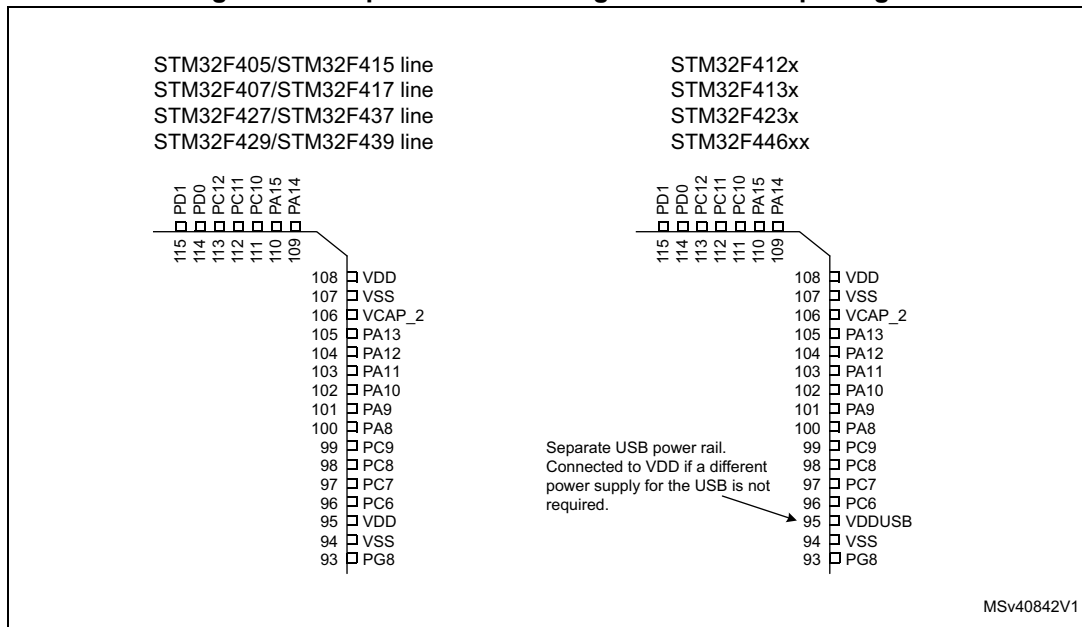
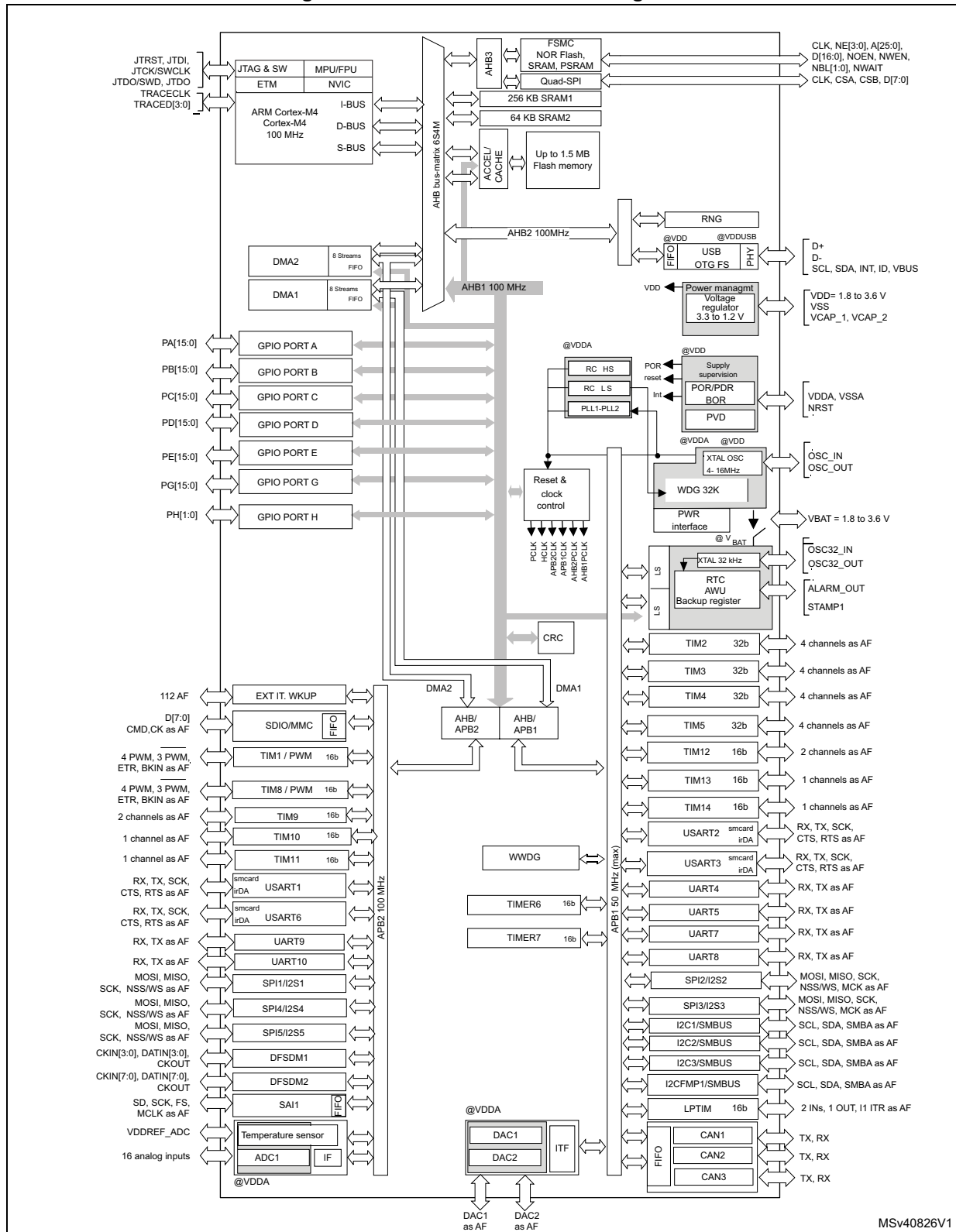

Figure 4. STM32F413xG/H block diagram



1. The timers connected to APB2 are clocked from TIMxCLK up to 100 MHz, while the timers connected to APB1 are clocked from TIMxCLK up to 50 MHz.

3 Functional overview

3.1 Arm[®] Cortex[®]-M4 with FPU core with embedded Flash and SRAM

The Arm[®] Cortex[®]-M4 with FPU processor is the latest generation of Arm processors for embedded systems. It was developed to provide a low-cost platform that meets the needs of MCU implementation, with a reduced pin count and low-power consumption, while delivering outstanding computational performance and an advanced response to interrupts.

The Arm[®] Cortex[®]-M4 with FPU 32-bit RISC processor features exceptional code-efficiency, delivering the high-performance expected from an Arm core in the memory size usually associated with 8- and 16-bit devices.

The processor supports a set of DSP instructions which allow efficient signal processing and complex algorithm execution.

Its single precision FPU (floating point unit) speeds up software development by using metalanguage development tools, while avoiding saturation.

The STM32F413xG/H devices are compatible with all Arm tools and software.

Figure 4 shows the general block diagram of the STM32F413xG/H.

Note: Cortex[®]-M4 with FPU is binary compatible with Cortex[®]-M3.

3.2 Adaptive real-time memory accelerator (ART Accelerator™)

The ART Accelerator™ is a memory accelerator which is optimized for STM32 industry-standard Arm[®] Cortex[®]-M4 with FPU processors. It balances the inherent performance advantage of the Arm[®] Cortex[®]-M4 with FPU over Flash memory technologies, which normally requires the processor to wait for the Flash memory at higher frequencies.

To release the processor full 125 DMIPS performance at this frequency, the accelerator implements an instruction prefetch queue and branch cache, which increases program execution speed from the 128-bit Flash memory. Based on CoreMark benchmark, the performance achieved thanks to the ART Accelerator is equivalent to 0 wait state program execution from Flash memory at a CPU frequency up to 100 MHz.

3.3 Enhanced Batch Acquisition mode (eBAM)

The Batch acquisition mode allows enhanced power efficiency during data batching. It enables data acquisition through any communication peripherals directly to memory using the DMA in reduced power consumption as well as data processing while the rest of the system is in low-power mode (including the Flash and ART). For example in an audio system, a smart combination of PDM audio sample acquisition and processing from the DFSDM directly to RAM (Flash and ART™ stopped) with the DMA using BAM followed by some very short processing from Flash allows to drastically reduce the power consumption of the application.

The BAM has been enhanced by adding SRAM2 that allows SRAM code to be executed through the Ibus and Dbus, thus improving code execution performance.

A dedicated application note (AN4515) describes how to implement the STM32F413xG/H BAM to allow the best power efficiency.

3.4 Memory protection unit

The memory protection unit (MPU) is used to manage the CPU accesses to memory to prevent one task to accidentally corrupt the memory or resources used by any other active task. This memory area is organized into up to 8 protected areas that can in turn be divided up into 8 subareas. The protection area sizes are between 32 byte and the whole 4 Gbyte of addressable memory.

The MPU is especially helpful for applications where some critical or certified code has to be protected against the misbehavior of other tasks. It is usually managed by an RTOS (real-time operating system). If a program accesses a memory location that is prohibited by the MPU, the RTOS can detect it and take action. In an RTOS environment, the kernel can dynamically update the MPU area setting, based on the process to be executed.

The MPU is optional and can be bypassed for applications that do not need it.

3.5 Embedded Flash memory

The devices embed up to 1.5 Mbytes of Flash memory available for storing programs and data, plus 512 bytes of one-time programmable (OTP) memory organized in 16 blocks of 32 bytes, each which can be independently locked.

The user Flash memory area can be protected against read operations by an entrusted code (read protection or RDP). Different protection levels are available. The user Flash memory is divided into sectors, which can be individually protected against write operation. Flash sectors can also be protected individually against D-bus read accesses by using the proprietary readout protection (PCROP).

Refer to the product line reference manual for additional information on OTP area and protection features.

To optimize the power consumption the Flash memory can also be switched off in Run or in Sleep mode (see [Section 3.20: Low-power modes](#)).

Two modes are available: Flash in Stop mode or in DeepSleep mode (trade off between power saving and startup time).

Before disabling the Flash, the code must be executed from the internal RAM.

3.6 CRC (cyclic redundancy check) calculation unit

The CRC (cyclic redundancy check) calculation unit is used to get a CRC code from a 32-bit data word and a fixed generator polynomial.

Among other applications, CRC-based techniques are used to verify data transmission or storage integrity. In the scope of the EN/IEC 60335-1 standard, they offer a means of verifying the Flash memory integrity. The CRC calculation unit helps compute a software signature during runtime, to be compared with a reference signature generated at link-time and stored at a given memory location.

3.7 Embedded SRAM

All devices embed 320 Kbytes of system SRAM which can be accessed (read/write) at CPU clock speed with 0 wait states.

3.8 Multi-AHB bus matrix

The 32-bit multi-AHB bus matrix interconnects all the masters (CPU, DMAs) and the slaves (Flash memory, RAM, AHB and APB peripherals) and ensures a seamless and efficient operation even when several high-speed peripherals work simultaneously.

Figure 5. Multi-AHB matrix

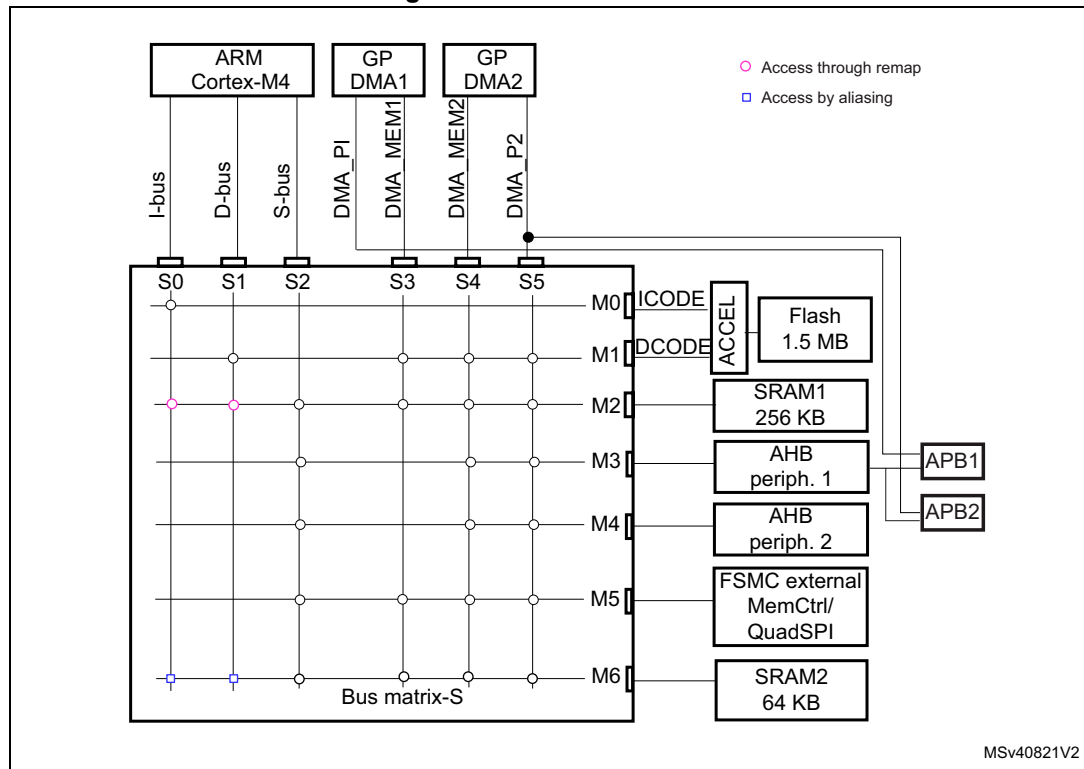

CPU can access SRAM1 memory via S-bus, when SRAM1 is mapped at the address range: 0x2000 0000 to 0x2003 FFFF.

CPU can access SRAM2 memory via S-bus, when SRAM2 is mapped at the address range: 0x2004 0000 to 0x2004 FFFF.

CPU can access SRAM1 memory via I-bus and D-bus, when SRAM1 is remapped at address 0x0000 0000 either by booting from RAM memory or by the remap mode.

CPU can access SRAM2 memory via I-bus and D-bus, when SRAM2 is mapped at the address range: 0x1000 0000 to 0x1000 FFFF.

Performance boosts up, when the CPU access SRAM memory via the I-bus.

3.9 DMA controller (DMA)

The devices feature two general-purpose dual-port DMAs (DMA1 and DMA2) with 8 streams each. They are able to manage memory-to-memory, peripheral-to-memory and memory-to-peripheral transfers. They feature dedicated FIFOs for APB/AHB peripherals, support burst transfer and are designed to provide the maximum peripheral bandwidth (AHB/APB).

The two DMA controllers support circular buffer management, so that no specific code is needed when the controller reaches the end of the buffer. The two DMA controllers also have a double buffering feature, which automates the use and switching of two memory buffers without requiring any special code.

Each stream is connected to dedicated hardware DMA requests, with support for software trigger on each stream. Configuration is made by software and transfer sizes between source and destination are independent.

The DMA can be used with the main peripherals:

- SPI and I²S
- I²C and I²C-FMP
- USART
- General-purpose, basic and advanced-control timers TIMx
- SD/SDIO/MMC/eMMC host interface
- Quad-SPI
- ADC
- DAC
- Digital Filter for sigma-delta modulator (DFSDM) with a separate stream for each filter
- SAI.

3.10 Flexible static memory controller (FSMC)

The Flexible static memory controller (FSMC) includes a NOR/PSRAM memory controller. It features four Chip Select outputs supporting the following modes: SRAM, PSRAM and NOR Flash memory.

The main functions are:

- 8-, 16-bit data bus width
- Write FIFO
- Maximum FSMC_CLK frequency for synchronous accesses is 90 MHz.

LCD parallel interface

The FSMC can be configured to interface seamlessly with most graphic LCD controllers. It supports the Intel 8080 and Motorola 6800 modes, and is flexible enough to adapt to specific LCD interfaces. This LCD parallel interface capability makes it easy to build cost-effective graphic applications using LCD modules with embedded controllers or high performance solutions using external controllers with dedicated acceleration.

3.11 Quad-SPI memory interface (QUAD-SPI)

All devices embed a Quad-SPI memory interface, which is a specialized communication interface targeting single, dual or quad-SPI Flash memories. It can work in direct mode through registers, external Flash status register polling mode and memory mapped mode. Up to 256 Mbyte of external Flash memory are mapped. They can be accessed in 8, 16 or 32-bit mode. Code execution is also supported. The opcode and the frame format are fully programmable. Communication can be performed either in single data rate or dual data rate.

3.12 Nested vectored interrupt controller (NVIC)

The devices embed a nested vectored interrupt controller able to manage 16 priority levels, and handle up to 102 maskable interrupt channels plus the 16 interrupt lines of the Cortex[®]-M4 with FPU.

- Closely coupled NVIC gives low-latency interrupt processing
- Interrupt entry vector table address passed directly to the core
- Allows early processing of interrupts
- Processing of late arriving, higher-priority interrupts
- Support tail chaining
- Processor state automatically saved
- Interrupt entry restored on interrupt exit with no instruction overhead

This hardware block provides flexible interrupt management features with minimum interrupt latency.

3.13 External interrupt/event controller (EXTI)

The external interrupt/event controller consists of 24 edge-detector lines used to generate interrupt/event requests. Each line can be independently configured to select the trigger event (rising edge, falling edge, both) and can be masked independently. A pending register maintains the status of the interrupt requests. The EXTI can detect an external line with a pulse width shorter than the Internal APB2 clock period. Up to 114 GPIOs can be connected to the 16 external interrupt lines.

3.14 Clocks and startup

On reset the 16 MHz internal RC oscillator is selected as the default CPU clock. The 16 MHz internal RC oscillator is factory-trimmed to offer 1% accuracy at 25 °C. The application can then select as system clock either the RC oscillator or an external 4-26 MHz clock source. This clock can be monitored for failure. If a failure is detected, the system automatically switches back to the internal RC oscillator and a software interrupt is generated (if enabled). This clock source is input to a PLL thus allowing to increase the frequency up to 100 MHz. Similarly, full interrupt management of the PLL clock entry is available when necessary (for example if an indirectly used external oscillator fails).

Several prescalers allow the configuration of the three AHB buses, the high-speed APB (APB2) and the low-speed APB (APB1) domains. The maximum frequency of the three AHB

buses and high-speed APB domains is 100 MHz. The maximum allowed frequency of the low-speed APB domain is 50 MHz.

The devices embed a dedicated PLL (PLL12S) which allows to achieve audio class performance. In this case, the I²S master clock can generate all standard sampling frequencies from 8 kHz to 192 kHz.

3.15 Boot modes

At startup, boot pins are used to select one out of three boot options:

- Boot from user Flash memory
- Boot from system memory
- Boot from embedded SRAM

The boot loader is located in system memory. It is used to reprogram the Flash memory by using one of the interface listed in the [Table 3](#) or the USB OTG FS in device mode through DFU (device firmware upgrade).

Table 3. Embedded bootloader interfaces

Package	USART1 PA9/ PA10	USART2 PD6/ PD5	USART3 PB11/ PB10	I2C1 PB6/ PB7	I2C2 PF0/ PF1	I2C3 PA8/ PB4	I2C FMP1 PB14/ PB15	SPI1 PA4/ PA5/ PA6/ PA7	SPI3 PA15/ PC10/ PC11/ PC12	SPI4 PE11/ PE12/ PE13/ PE14	CAN2 PB5/ PB13	USB PA11 /P12
UFQFPN48	Y	-	-	Y	-	Y	Y	Y	-	-	Y	Y
LQFP64	Y	-	-	Y	-	Y	Y	Y	Y	-	Y	Y
WLCSP81	Y	-	-	Y	-	Y	Y	Y	Y	Y	Y	Y
LQFP100	Y	Y	-	Y	-	Y	Y	Y	Y	Y	Y	Y
LQFP144	Y	Y	Y	Y	Y	Y	Y	Y	Y	Y	Y	Y
UFBGA100	Y	Y	Y	Y	-	Y	Y	Y	Y	Y	Y	Y
UFBGA144	Y	Y	Y	Y	Y	Y	Y	Y	Y	Y	Y	Y

For more detailed information on the bootloader, refer to Application Note: AN2606, *STM32™ microcontroller system memory boot mode*.

3.16 Power supply schemes

- $V_{DD} = 1.7$ to 3.6 V: external power supply for I/Os with the internal supervisor (POR/PDR) disabled, provided externally through V_{DD} pins. Requires the use of an external power supply supervisor connected to the V_{DD} and NRST pins.
- $V_{SSA}, V_{DDA} = 1.7$ to 3.6 V: external analog power supplies for ADC, Reset blocks, RCs and PLL. V_{DDA} and V_{SSA} must be connected to V_{DD} and V_{SS} , respectively, with decoupling technique.

Note: The V_{DD}/V_{DDA} minimum value of 1.7 V is obtained with the use of an external power supply supervisor (refer to [Section 3.17.2: Internal reset OFF](#)). Refer to [Table 4: Regulator ON/OFF and internal power supply supervisor availability](#) to identify the packages supporting this option.

- $V_{BAT} = 1.65$ to 3.6 V: power supply for RTC, external clock 32 kHz oscillator and backup registers (through power switch) when V_{DD} is not present.
- V_{DDUSB} can be connected either to VDD or an external independent power supply (3.0 to 3.6 V) for USB transceivers.

For example, when device is powered at 1.8 V, an independent power supply 3.3 V can be connected to V_{DDUSB} . When the V_{DDUSB} is connected to a separated power supply, it is independent from V_{DD} or V_{DDA} but it must be the last supply to be provided and the first to disappear.

The following conditions V_{DDUSB} must be respected:

- During power-on phase ($V_{DD} < V_{DD_MIN}$), V_{DDUSB} should be always lower than V_{DD}
- During power-down phase ($V_{DD} < V_{DD_MIN}$), V_{DDUSB} should be always lower than V_{DD}
- V_{DDUSB} rising and falling time rate specifications must be respected.
- In operating mode phase, V_{DDUSB} could be lower or higher than VDD:
 - If USB is used, the associated GPIOs powered by V_{DDUSB} are operating between V_{DDUSB_MIN} and V_{DDUSB_MAX} .
 - If USB is not used, the associated GPIOs powered by V_{DDUSB} are operating between V_{DD_MIN} and V_{DD_MAX} .

Figure 6. V_{DDUSB} connected to an external independent power supply

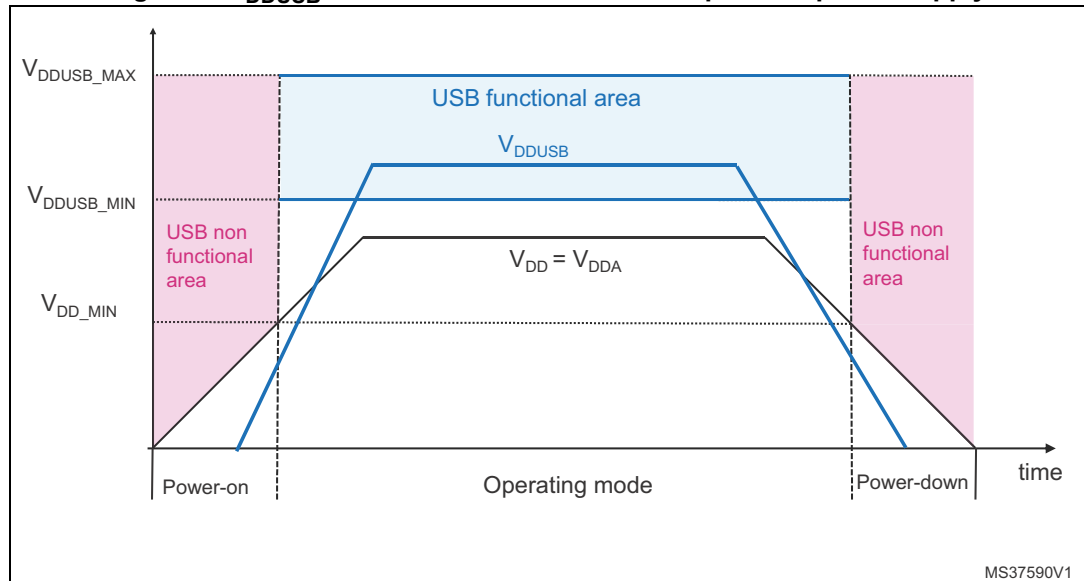

3.17 Power supply supervisor

3.17.1 Internal reset ON

This feature is available for V_{DD} operating voltage range 1.8 V to 3.6 V.

On packages embedding the PDR_ON pin, the power supply supervisor is enabled by holding PDR_ON high. On the other package, the power supply supervisor is always enabled.

The device has an integrated power-on reset (POR) / power-down reset (PDR) circuitry coupled with a Brownout reset (BOR) circuitry. At power-on, POR is always active, and ensures proper operation starting from 1.8 V. After the 1.8 V POR threshold level is reached, the option byte loading process starts, either to confirm or modify default thresholds, or to disable BOR permanently. Three BOR thresholds are available through option bytes.

The device remains in reset mode when V_{DD} is below a specified threshold, $V_{POR/PDR}$ or V_{BOR} , without the need for an external reset circuit.

The device also features an embedded programmable voltage detector (PVD) that monitors the V_{DD}/V_{DDA} power supply and compares it to the V_{PVD} threshold. An interrupt can be generated when V_{DD}/V_{DDA} drops below the V_{PVD} threshold and/or when V_{DD}/V_{DDA} is higher than the V_{PVD} threshold. The interrupt service routine can then generate a warning message and/or put the MCU into a safe state. The PVD is enabled by software.

3.17.2 Internal reset OFF

This feature is available only on packages featuring the PDR_ON pin. The internal power-on reset (POR) / power-down reset (PDR) circuitry is disabled by setting the PDR_ON pin to low.

An external power supply supervisor should monitor V_{DD} and should set the device in reset mode when V_{DD} is below 1.7 V. NRST should be connected to this external power supply supervisor. Refer to [Figure 7: Power supply supervisor interconnection with internal reset OFF](#).

Figure 7. Power supply supervisor interconnection with internal reset OFF⁽¹⁾

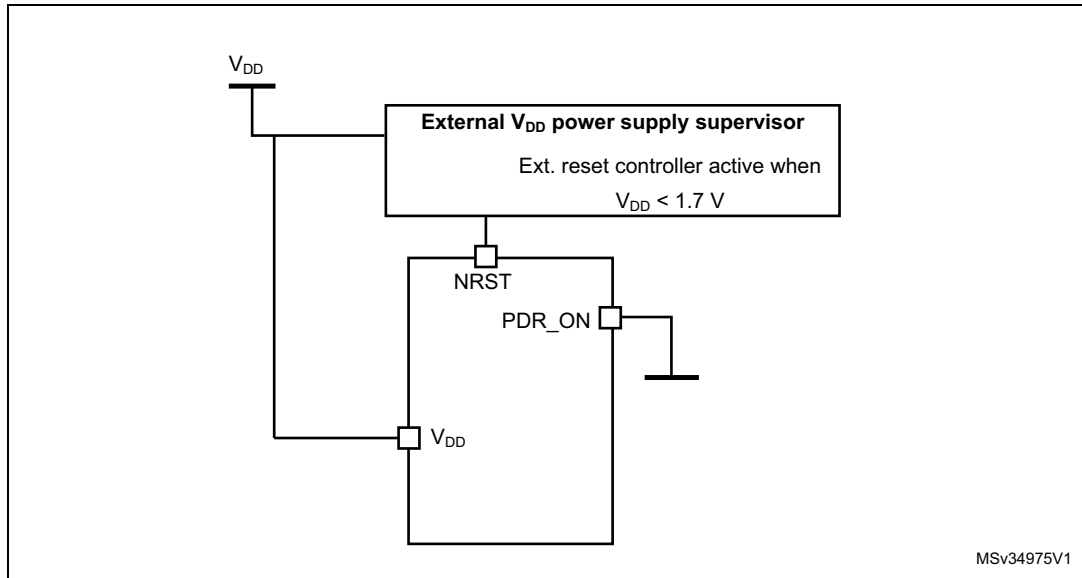

1. The PRD_ON pin is available only on WLCSP81, UFBGA100, UFBGA144 and LQFP144 packages.

A comprehensive set of power-saving mode allows to design low-power applications.

When the internal reset is OFF, the following integrated features are no longer supported:

- The integrated power-on reset (POR) / power-down reset (PDR) circuitry is disabled.
- The brownout reset (BOR) circuitry must be disabled.
- The embedded programmable voltage detector (PVD) is disabled.
- V_{BAT} functionality is no more available and VBAT pin should be connected to V_{DD} .

3.18 Voltage regulator

The regulator has three operating modes:

- Main regulator mode (MR)
- Low power regulator (LPR)
- Power-down

3.18.1 Regulator ON

On packages embedding the BYPASS_REG pin, the regulator is enabled by holding BYPASS_REG low. On all other packages, the regulator is always enabled.

There are three power modes configured by software when the regulator is ON:

- MR is used in the nominal regulation mode (With different voltage scaling in Run mode)
In Main regulator mode (MR mode), different voltage scaling are provided to reach the best compromise between maximum frequency and dynamic power consumption.
- LPR is used in the Stop mode
The LP regulator mode is configured by software when entering Stop mode.
- Power-down is used in Standby mode.
The Power-down mode is activated only when entering in Standby mode. The regulator output is in high impedance and the kernel circuitry is powered down, inducing zero consumption. The contents of the registers and SRAM are lost.

Depending on the package, one or two external ceramic capacitors should be connected on the VCAP_1 and VCAP_2 pins. The VCAP_2 pin is only available on 100- and 144-pin packages.

All packages have the regulator ON feature.

3.18.2 Regulator OFF

This feature is available only on UFBGA100 and UFBGA144 packages, which feature the BYPASS_REG pin. The regulator is disabled by holding BYPASS_REG high. The regulator OFF mode allows to supply externally a V_{12} voltage source through VCAP_1 and VCAP_2 pins.

Since the internal voltage scaling is not managed internally, the external voltage value must be aligned with the targeted maximum frequency.

The two 2.2 μ F ceramic capacitors should be replaced by two 100 nF decoupling capacitors.

When the regulator is OFF, there is no more internal monitoring on V_{12} . An external power supply supervisor should be used to monitor the V_{12} of the logic power domain. PA0 pin should be used for this purpose, and act as power-on reset on V_{12} power domain.

In regulator OFF mode, the following features are no more supported:

- PA0 cannot be used as a GPIO pin since it allows to reset a part of the V_{12} logic power domain which is not reset by the NRST pin.
- As long as PA0 is kept low, the debug mode cannot be used under power-on reset. As a consequence, PA0 and NRST pins must be managed separately if the debug connection under reset or pre-reset is required.

Figure 8. Regulator OFF

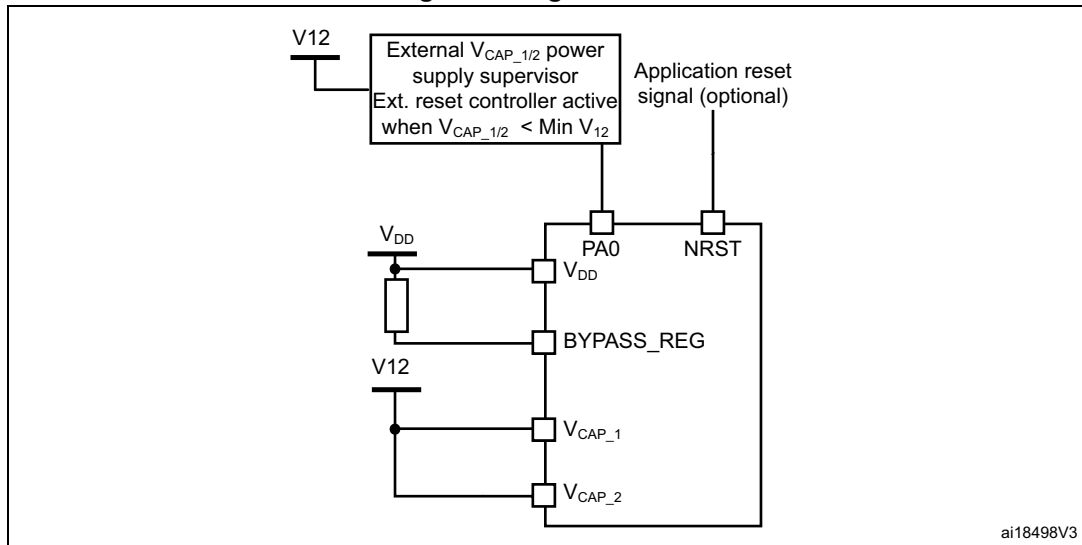

The following conditions must be respected:

- V_{DD} should always be higher than V_{CAP_1} and V_{CAP_2} to avoid current injection between power domains.
- If the time for V_{CAP_1} and V_{CAP_2} to reach V_{12} minimum value is faster than the time for V_{DD} to reach 1.7 V, then PA0 should be kept low to cover both conditions: until V_{CAP_1} and V_{CAP_2} reach V_{12} minimum value and until V_{DD} reaches 1.7 V (see [Figure 9](#)).
- Otherwise, if the time for V_{CAP_1} and V_{CAP_2} to reach V_{12} minimum value is slower than the time for V_{DD} to reach 1.7 V, then PA0 could be asserted low externally (see [Figure 10](#)).
- If V_{CAP_1} and V_{CAP_2} go below V_{12} minimum value and V_{DD} is higher than 1.7 V, then a reset must be asserted on PA0 pin.

Note: The minimum value of V_{12} depends on the maximum frequency targeted in the application.

Figure 9. Startup in regulator OFF: slow V_{DD} slope power-down reset risen after V_{CAP_1}/V_{CAP_2} stabilization

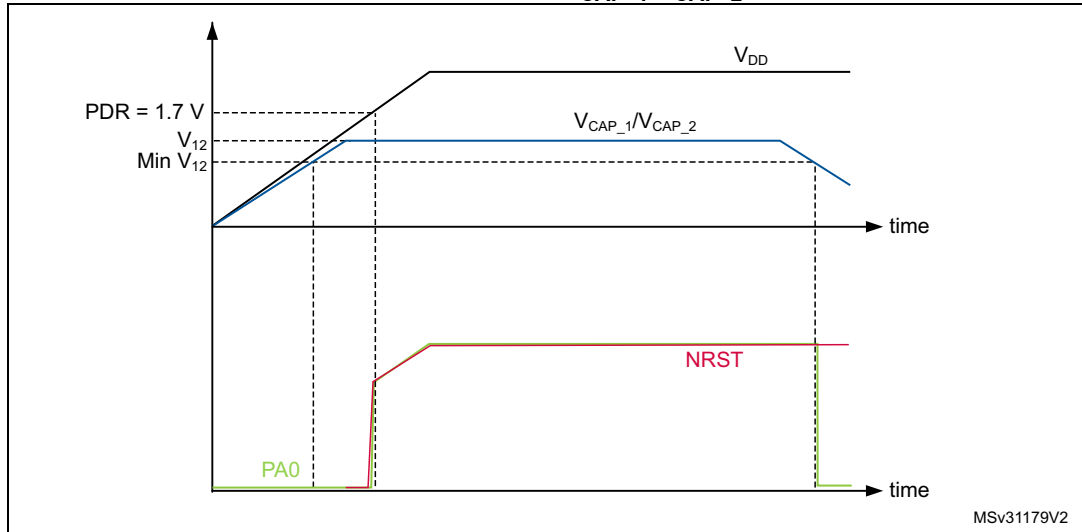

1. This figure is valid whatever the internal reset mode (ON or OFF).

Figure 10. Startup in regulator OFF mode: fast V_{DD} slope power-down reset risen before V_{CAP_1}/V_{CAP_2} stabilization

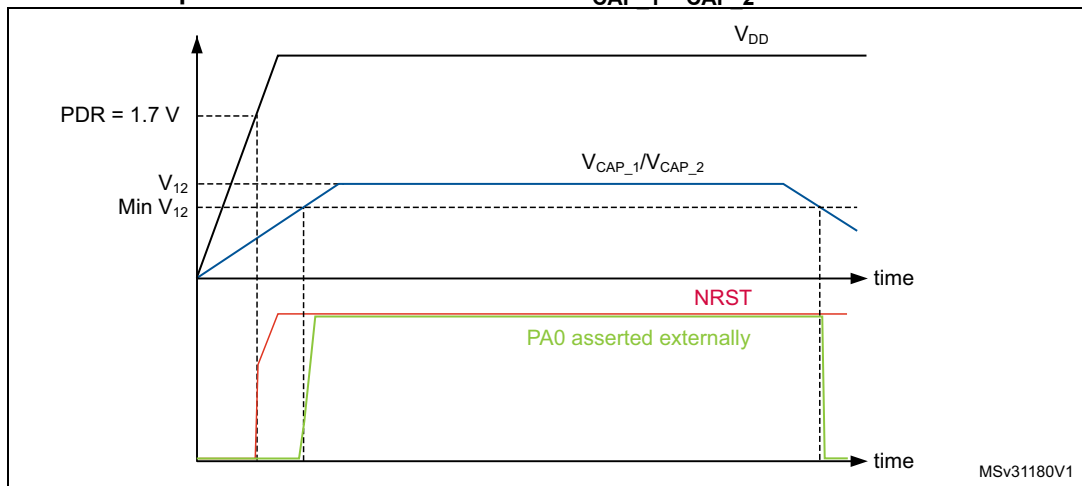

1. This figure is valid whatever the internal reset mode (ON or OFF).

3.18.3 Regulator ON/OFF and internal reset ON/OFF availability

Table 4. Regulator ON/OFF and internal power supply supervisor availability

Package	Regulator ON	Regulator OFF	Power supply supervisor ON	Power supply supervisor OFF
UFQFPN48	Yes	No	Yes	No
LQFP64	Yes	No	Yes	No
WLCSP81	Yes BYPASS_REG set to V_{SS}	Yes BYPASS_REG set to V_{DD}	Yes PDR_ON set to V_{DD}	Yes PDR_ON set to V_{SS}
LQFP100	Yes	No	Yes	No
LQFP144	Yes	No	Yes PDR_ON set to V_{DD}	Yes PDR_ON set to V_{SS}
UFBGA100	Yes BYPASS_REG set to V_{SS}	Yes BYPASS_REG set to V_{DD}		
UFBGA144	Yes BYPASS_REG set to V_{SS}	Yes BYPASS_REG set to V_{DD}		

3.19 Real-time clock (RTC) and backup registers

The backup domain includes:

- The real-time clock (RTC)
- 20 backup registers

The real-time clock (RTC) is an independent BCD timer/counter. Dedicated registers contain the second, minute, hour (in 12/24 hour), week day, date, month, year, in BCD (binary-coded decimal) format. Correction for 28, 29 (leap year), 30, and 31 day of the month are performed automatically. The RTC features a reference clock detection, a more precise second source clock (50 or 60 Hz) can be used to enhance the calendar precision. The RTC provides a programmable alarm and programmable periodic interrupts with wakeup from Stop and Standby modes. The sub-seconds value is also available in binary format.

It is clocked by a 32.768 kHz external crystal, resonator or oscillator, the internal low-power RC oscillator or the high-speed external clock divided by 128. The internal low-speed RC has a typical frequency of 32 kHz. The RTC can be calibrated using an external 512 Hz output to compensate for any natural quartz deviation.

Two alarm registers are used to generate an alarm at a specific time and calendar fields can be independently masked for alarm comparison. To generate a periodic interrupt, a 16-bit programmable binary auto-reload downcounter with programmable resolution is available and allows automatic wakeup and periodic alarms from every 120 μ s to every 36 hours.

A 20-bit prescaler is used for the time base clock. It is by default configured to generate a time base of 1 second from a clock at 32.768 kHz.

The backup registers are 32-bit registers used to store 80 byte of user application data when V_{DD} power is not present. Backup registers are not reset by a system, a power reset, or when the device wakes up from the Standby mode (see [Section 3.20: Low-power modes](#)).

Additional 32-bit registers contain the programmable alarm subseconds, seconds, minutes, hours, day, and date.

The RTC and backup registers are supplied through a switch that is powered either from the V_{DD} supply when present or from the VBAT pin.

3.20 Low-power modes

The devices support three low-power modes to achieve the best compromise between low power consumption, short startup time and available wakeup sources:

- **Sleep mode**

In Sleep mode, only the CPU is stopped. All peripherals continue to operate and can wake up the CPU when an interrupt/event occurs.

To further reduce the power consumption, the Flash memory can be switched off before entering in Sleep mode. Note that this requires a code execution from the RAM.

- **Stop mode**

The Stop mode achieves the lowest power consumption while retaining the contents of SRAM and registers. All clocks in the 1.2 V domain are stopped, the PLL, the HSI RC and the HSE crystal oscillators are disabled. The voltage regulator can also be put either in normal or in low-power mode.

The device can be woken up from the Stop mode by any of the EXTI line (the EXTI line source can be one of the 16 external lines, the PVD output, the RTC alarm/ wakeup/ tamper/ time stamp events).

- **Standby mode**

The Standby mode is used to achieve the lowest power consumption. The internal voltage regulator is switched off so that the entire 1.2 V domain is powered off. The PLL, the HSI RC and the HSE crystal oscillators are also switched off. After entering Standby mode, the SRAM and register contents are lost except for registers in the backup domain when selected.

The device exits the Standby mode when an external reset (NRST pin), an IWDG reset, a rising edge on one of the WKUP pins, or an RTC alarm/ wakeup/ tamper/time stamp event occurs.

Standby mode is not supported when the embedded voltage regulator is bypassed and the 1.2 V domain is controlled by an external power.

3.21 V_{BAT} operation

The VBAT pin allows to power the device V_{BAT} domain from an external battery, an external super-capacitor, or from V_{DD} when no external battery and an external super-capacitor are present.

V_{BAT} operation is activated when V_{DD} is not present.

The VBAT pin supplies the RTC and the backup registers.

Note: When the microcontroller is supplied from V_{BAT} , external interrupts and RTC alarm/events do not exit it from V_{BAT} operation. When PDR_ON pin is not connected to V_{DD} (internal Reset OFF), the V_{BAT} functionality is no more available and VBAT pin should be connected to V_{DD} .

3.22 Timers and watchdogs

The devices embed two advanced-control timer, ten general-purpose timers, two basic timers, one low-power timer, two watchdog timers and a SysTick timer.

All timer counters can be frozen in debug mode.

[Table 5](#) compares the features of the advanced-control and general-purpose timers.

Table 5. Timer feature comparison

Timer type	Timer	Counter resolution	Counter type	Prescaler factor	DMA request generation	Capture/compare channels	Complementary output	Max. interface clock (MHz)	Max. timer clock (MHz)
Advanced-control	TIM1, TIM8	16-bit	Up, Down, Up/down	Any integer between 1 and 65536	Yes	4	Yes	100	100
General purpose	TIM2, TIM5	32-bit	Up, Down, Up/down	Any integer between 1 and 65536	Yes	4	No	50	100
	TIM3, TIM4	16-bit	Up, Down, Up/down	Any integer between 1 and 65536	Yes	4	No	50	100
	TIM9	16-bit	Up	Any integer between 1 and 65536	No	2	No	100	100
	TIM10, TIM11	16-bit	Up	Any integer between 1 and 65536	No	1	No	100	100
	TIM12	16-bit	Up	Any integer between 1 and 65536	No	2	No	50	100
	TIM13, TIM14	16-bit	Up	Any integer between 1 and 65536	No	1	No	50	100

Table 5. Timer feature comparison (continued)

Timer type	Timer	Counter resolution	Counter type	Prescaler factor	DMA request generation	Capture/compare channels	Complementary output	Max. interface clock (MHz)	Max. timer clock (MHz)
Basic timers	TIM6, TIM7	16-bit	Up	Any integer between 1 and 65536	Yes	0	No	50	100
Low-power timer	LPTIM1	16-bit	Up	Between 1 and 128	No	2	No	50	100

3.22.1 Advanced-control timers (TIM1, TIM8)

The advanced-control timers (TIM1/8) can be seen as three-phase PWM generator multiplexed on 4 independent channels. They have complementary PWM outputs with programmable inserted dead times. They can also be considered as complete general-purpose timers. Their 4 independent channels can be used for:

- Input capture
- Output compare
- PWM generation (edge- or center-aligned modes)
- One-pulse mode output

If configured as standard 16-bit timers, they have the same features as the general-purpose TIMx timers. If configured as a 16-bit PWM generator, they have full modulation capability (0-100%).

The advanced-control timers can work together with the TIMx timers via the Timer Link feature for synchronization or event chaining.

TIM1 and TIM8 support independent DMA request generation.

3.22.2 General-purpose timers (TIMx)

There are eleven synchronizable general-purpose timers embedded in the STM32F413xG/H (see [Table 5](#) for differences).

- **TIM2, TIM3, TIM4, TIM5**

The STM32F413xG/H devices include 4 full-featured general-purpose timers: TIM2, TIM3, TIM4 and TIM5. TIM2 and TIM5 timers are based on a 32-bit auto-reload up/downcounter and a 16-bit prescaler while TIM3 and TIM4 timers are based on a 16-bit auto-reload up/downcounter plus a 16-bit prescaler. They all features four

independent channels for input capture/output compare, PWM or one-pulse mode output. This gives up to 15 input capture/output compare/PWMs

TIM2, TIM3, TIM4 and TIM5 general-purpose timers can operate together or in conjunction with the other general-purpose timers and TIM1 advanced-control timer via the Timer Link feature for synchronization or event chaining.

Any of these general-purpose timers can be used to generate PWM output.

TIM2, TIM3, TIM4 and TIM5 channels have independent DMA request generation. They are capable of handling quadrature (incremental) encoder signals and the digital outputs from 1 to 4 hall-effect sensors.

- **TIM9, TIM10, TIM11, TIM12, TIM13 and TIM14**

These timers are based on a 16-bit auto-reload upcounter and a 16-bit prescaler. TIM10, TIM11, TIM13 and TIM14 feature one independent channel, whereas TIM9 and TIM12 have two independent channels for input capture/output compare, PWM or one-pulse mode output. They can be synchronized with TIM2, TIM3, TIM4 and TIM5 full-featured general-purpose timers or used as simple time bases.

3.22.3 Basic timer (TIM6, TIM7)

TIM6 and TIM7 timers are basic 16-bit timers. They support independent DMA request generation.

3.22.4 Low-power timer (LPTIM1)

The low-power timer (LPTIM1) features an independent clock and runs in Stop mode if it is clocked by LSE, LSI or by an external clock. LPTIM1 is able to wakeup the devices from Stop mode.

The low-power timer main features are the following:

- 16-bit up counter with 16-bit autoreload register
- 16-bit compare register
- Configurable output: pulse, PWM
- Continuous / one shot mode
- Selectable software / hardware input trigger
- Selectable clock source
 - Internal clock source: LSE, LSI, HSI or APB1 clock
 - External clock source over LPTIM1 input (working even with no internal clock source running, used by the pulse counter application)
- Programmable digital glitch filter
- Encoder mode
- Active in Stop mode.

3.22.5 Independent watchdog

The independent watchdog is based on a 12-bit downcounter and 8-bit prescaler. It is clocked from an independent 32 kHz internal RC and as it operates independently from the main clock, it can operate in Stop and Standby modes. It can be used either as a watchdog to reset the device when a problem occurs, or as a free-running timer for application timeout management. It is hardware- or software-configurable through the option bytes.

3.22.6 Window watchdog

The window watchdog is based on a 7-bit downcounter that can be set as free-running. It can be used as a watchdog to reset the device when a problem occurs. It is clocked from the main clock. It has an early warning interrupt capability and the counter can be frozen in debug mode.

3.22.7 SysTick timer

This timer is dedicated to real-time operating systems, but could also be used as a standard downcounter. It features:

- A 24-bit downcounter
- Autoreload capability
- Maskable system interrupt generation when the counter reaches 0
- Programmable clock source.

3.23 Inter-integrated circuit interface (I²C)

The devices feature up to four I²C bus interfaces which can operate in multimaster and slave modes:

- One I²C interface supports the Standard mode (up to 100 kHz), Fast-mode (up to 400 kHz) modes and Fast-mode plus (up to 1 MHz).
- Three I²C interfaces support the Standard mode (up to 100 KHz) and the Fast mode (up to 400 KHz). Their frequency can be increased up to 1 MHz. For more details on the complete solution, refer to the nearest STMicroelectronics sales office.

All I²C interfaces features 7/10-bit addressing mode and 7-bit addressing mode (as slave) and embed a hardware CRC generation/verification.

They can be served by DMA and they support SMBus 2.0/PMBus.

The devices also include programmable analog and digital noise filters (see [Table 6](#)).

Table 6. Comparison of I2C analog and digital filters

	Analog filter	Digital filter
Pulse width of suppressed spikes	≥ 50 ns	Programmable length from 1 to 15 I2C peripheral clocks

3.24 Universal synchronous/asynchronous receiver transmitters (USART)

The devices embed four universal synchronous/asynchronous receiver transmitters (USART1, USART2, USART3 and USART6) as well as six universal asynchronous receiver transmitters (UART4, UART5, UART7, UART8, UART9 and UART10).

These ten interfaces provide asynchronous communication, IrDA SIR ENDEC support, multiprocessor communication mode, single-wire half-duplex communication mode and have LIN Master/Slave capability. USART1, USART6, UART9 and UART10 can communicate at speeds up to 12.5 Mbit/s. The other interfaces communicate at up to 6.25 bit/s.

USART1, USART2, USART3 and USART6 provide hardware management of the CTS and RTS signals, Smart Card mode (ISO 7816 compliant) and SPI-like communication capability. All interfaces can be served by the DMA controller.

Table 7. USART feature comparison

USART name	Standard features	Modem (RTS/CTS)	LIN	SPI master	irDA	Smartcard (ISO 7816)	Max. baud rate in Mbit/s (oversampling by 16)	Max. baud rate in Mbit/s (oversampling by 8)	APB mapping
USART1	X	X	X	X	X	X	6.25	12.5	APB2 (max. 100 MHz)
USART2	X	X	X	X	X	X	3.12	6.25	APB1 (max. 50 MHz)
USART3	X	X	X	X	X	X	3.12	6.25	APB1 (max. 50 MHz)
UART4	X	-	X	-	X	-	3.12	6.25	APB1 (max. 50 MHz)
UART5	X	-	X	-	X	-	3.12	6.25	APB1 (max. 50 MHz)
USART6	X	X	X	X	X	X	6.25	12.5	APB2 (max. 100 MHz)
UART7	X	-	X	-	X	-	3.12	6.25	APB1 (max. 50 MHz)
UART8	X	-	X	-	X	-	3.12	6.25	APB1 (max. 50 MHz)
UART9	X	-	X	-	X	-	6.25	12.5	APB2 (max. 100 MHz)
UART10	X	-	X	-	X	-	6.25	12.5	APB2 (max. 100 MHz)

3.25 Serial peripheral interface (SPI)

The devices feature five SPIs in slave and master modes in full-duplex and simplex communication modes. SPI1, SPI4 and SPI5 can communicate at up to 50 Mbit/s, SPI2 and SPI3 can communicate at up to 25 Mbit/s. The 3-bit prescaler gives 8 master mode frequencies and the frame is configurable to 8 bits or 16 bits. The hardware CRC generation/verification supports basic SD Card/MMC modes. All SPIs can be served by the DMA controller.

The SPI interfaces can be configured to operate in TI mode for communications in master mode and slave mode.

3.26 Inter-integrated sound (I²S)

Five standard I²S interfaces (multiplexed with SPI1 to SPI5) are available. They can be operated in master or slave mode, in simplex communication mode, and full duplex mode for I2S2 and I2S3. All I²S interfaces can be configured to operate with a 16-/32-bit resolution as an input or output channel. I2Sx audio sampling frequencies from 8 kHz up to 192 kHz are supported. When either or both of the I²S interfaces is/are configured in master mode, the master clock can be output to the external DAC/CODEC at 256 times the sampling frequency.

All I²Sx interfaces can be served by the DMA controller.

3.27 Serial Audio interface (SAI1)

The serial audio interface (SAI1) is based on two independent audio sub-blocks which can operate as transmitter or receiver with their FIFO. Many audio protocols are supported by each block: I2S standards, LSB or MSB-justified, PCM/DSP, TDM, AC'97 and SPDIF output, supporting audio sampling frequencies from 8 kHz up to 192 kHz. Both sub-blocks can be configured in master or in slave mode.

In master mode, the master clock can be output to the external DAC/CODEC at 256 times of the sampling frequency.

The two sub-blocks can be configured in synchronous mode when full-duplex mode is required.

SAI1 can be served by the DMA controller.

3.28 Audio PLL (PLLI2S)

The devices feature an additional dedicated PLL for audio I²S and SAI applications. It allows to achieve error-free I²S sampling clock accuracy without compromising on the CPU performance, while using USB peripherals.

Different sources can be selected for the I2S master clock of the APB1 and the I2S master clock of the APB2. This gives the flexibility to work with two different audio sampling frequencies. The different possible sources are the main PLL, the PLLI2S, HSE or HSI clocks or an external clock provided through a pin (external PLL or CODEC output)

Different sources can also be selected for the SAI. The different possible sources are the main PLL, the PLLI2S, HSE or HSI clocks or an external clock provided through a pin (external PLL or CODEC output).

The PLLI2S configuration can be modified to manage an I²S/SAI sample rate change without disabling the main PLL (PLL) used for CPU, USB and Ethernet interfaces.

The audio PLL can be programmed with very low error to obtain sampling rates ranging from 8 KHz to 192 KHz.

3.29 Digital filter for sigma-delta modulators (DFSDM)

The device embeds two DFSDMs:

- DFSDM1 has 2 digital filters modules and 4 external input serial channels (transceivers) or alternately 2 internal parallel inputs support.
- DFSDM2 features 4 digital filters modules and 8 external input serial channels (transceivers) or alternately 4 internal parallel inputs support.

The amount of filters defines the number of conversions which can be performed simultaneously.

The DFSDM peripheral is dedicated to interface the external $\Sigma\Delta$ modulators to microcontroller and then to perform digital filtering of the received data streams (which represent analog value on $\Sigma\Delta$ modulators inputs). DFSDM can also interface PDM (Pulse Density Modulation) microphones and perform PDM to PCM conversion and filtering in hardware. It is also possible to introduce a programmable delay between different microphones (beamforming feature). DFSDM features optional parallel data stream inputs from microcontrollers memory (through DMA/CPU transfers into DFSDM).

DFSDM transceivers support several serial interface formats (to support various $\Sigma\Delta$ modulators). DFSDM digital filter modules perform digital processing according user selected filter parameters with up to 24-bit final ADC resolution.

Table 8. DFSDM feature comparison

DFSDM instance	External input serial channels	External input parallel channels	Digital filters
DFSDM1	4	2	2
DFSDM2	8	4	4

3.30 Dynamic tuning of PDM delays for sound source localization

A mechanism is implemented on top of the DFSDM allowing to dynamically tune PDM delays of each microphone without the need to add external delay lines.

Audio application with several microphones require strong microphones placement constraints, as the distance between the microphones must be a multiple of v/F where v is the speed of the sound and F is the PCM sampling frequency.

The designed mechanism removes this constraint by programming delays for each digital microphone with the granularity of the PDM clock rate prior to the conversion into PCM rate.

The tuning delay is performed by a clock skipping technique.

The strong benefits of such mechanism coupled with DFSDM are:

- Possibility to place the digital microphones close to each other
- No need for external delay lines
- The delay tuning is done in hardware, preventing the use of MIPs crunching algorithms
- Possibility to change the delay tuning on the fly
- The low power consumption and CPU time released due to the DFSDM hardware PDM to PCM conversion

The impacted audio application are beam forming and sound source localization

3.31 Secure digital input/output interface (SDIO)

An SD/SDIO/MMC host interface is available, that supports MultiMediaCard System Specification Version 4.2 in three different databus modes: 1-bit (default), 4-bit and 8-bit.

The interface allows data transfer at up to 50 MHz, and is compliant with the SD Memory Card Specification Version 2.0.

The SDIO Card Specification Version 2.0 is also supported with two different databus modes: 1-bit (default) and 4-bit.

The current version supports only one SD/SDIO/MMC4.2 card at any one time and a stack of MMC4.1 or previous.

In addition to SD/SDIO/MMC/eMMC, this interface is fully compliant with the CE-ATA digital protocol Rev1.1.

3.32 Controller area network (bxCAN)

The three CANs are compliant with the 2.0A and B (active) specifications with a bitrate up to 1 Mbit/s. They can receive and transmit standard frames with 11-bit identifiers as well as extended frames with 29-bit identifiers. Each CAN has three transmit mailboxes, two receive FIFOs with 3 stages and 28 shared scalable filter banks (all of them can be used even if one CAN is used). 256 bytes of SRAM are allocated for CAN1 and CAN2, and 512 bytes for CAN3.

3.33 Universal serial bus on-the-go full-speed (USB_OTG_FS)

The devices embed a USB OTG full-speed device/host/OTG peripheral with integrated transceivers. The USB OTG FS peripheral is compliant with USB 2.0 and OTG 1.0 specifications. It features software-configurable endpoint setting and supports suspend/resume. The USB OTG full-speed controller requires a dedicated 48 MHz clock, which is generated by a PLL connected to the HSE oscillator. The Battery Charging Detection (BCD) can detect and identify the type of port it is connected to (standard USB or charger). The charging type can also be detected: Dedicated Charging Port (DCP), Charging Downstream Port (CDP) and Standard Downstream Port (SDP).

Some packages provide a dedicated USB power rail allowing to supply the USB from a different voltage than the rest of the device. As an example, the device can be powered with the minimum specified supply voltage while the USB runs at the level defined by the standard.

The main USB OTG FS features are:

- Combined Rx and Tx FIFO size of 320 × 35 bits with dynamic FIFO sizing
- Support of session request protocol (SRP) and host negotiation protocol (HNP)
- 6 bidirectional endpoints
- 12 host channels with periodic OUT support
- HNP/SNP/IP inside (no need for any external resistor)
- For OTG/Host modes, a power switch is needed when bus-powered devices are connected
- Link Power Management (LPM)
- Battery Charging Detection (BCD) supporting DCP, CDP and SDP

3.34 Random number generator (RNG)

All devices embed an RNG that delivers 32-bit random numbers generated by an integrated analog circuit.

3.35 General-purpose input/outputs (GPIOs)

Each of the GPIO pins can be configured by software as output (push-pull or open-drain, with or without pull-up or pull-down), as input (floating, with or without pull-up or pull-down) or as peripheral alternate function. Most of the GPIO pins are shared with digital or analog alternate functions. All GPIOs are high-current-capable and have speed selection to better manage internal noise, power consumption and electromagnetic emission.

The I/O configuration can be locked if needed by following a specific sequence in order to avoid spurious writing to the I/Os registers.

Fast I/O handling allowing maximum I/O toggling up to 100 MHz.

3.36 Analog-to-digital converter (ADC)

One 12-bit analog-to-digital converter is embedded and shares up to 16 external channels, performing conversions in the single-shot or scan mode. In scan mode, automatic conversion is performed on a selected group of analog inputs.

The ADC can be served by the DMA controller. An analog watchdog feature allows very precise monitoring of the converted voltage of one, some or all selected channels. An interrupt is generated when the converted voltage is outside the programmed thresholds.

To synchronize A/D conversion and timers, the ADCs could be triggered by any of TIM1, TIM2, TIM3, TIM4 or TIM5 timer.

3.37 Digital to analog converter (DAC)

The two 12-bit buffered DAC channels can be used to convert two digital signals into two analog voltage signal outputs.

This digital interface supports the following features:

- Two DAC output channels

- 8-bit or 12-bit output mode
- Left or right data alignment in 12-bit mode
- Synchronized update capability
- Noise-wave generation
- Triangular-wave generation
- Dual DAC channel independent or simultaneous conversions
- DMA capability for each channel
- External triggers for conversion
- Input voltage reference (V_{REF+})

Eight DAC trigger inputs are used in the device. The DAC channels are triggered through the timer update outputs that are also connected to different DMA channels.

3.38 Temperature sensor

The temperature sensor has to generate a voltage that varies linearly with temperature. The conversion range is between 1.7 V and 3.6 V. The temperature sensor is internally connected to the ADC_IN18 input channel which is used to convert the sensor output voltage into a digital value. Refer to the reference manual for additional information.

As the offset of the temperature sensor varies from chip to chip due to process variation, the internal temperature sensor is mainly suitable for applications that detect temperature changes instead of absolute temperatures. If an accurate temperature reading is needed, then an external temperature sensor part should be used.

3.39 Serial wire JTAG debug port (SWJ-DP)

The Arm SWJ-DP interface is embedded, and is a combined JTAG and serial wire debug port that enables either a serial wire debug or a JTAG probe to be connected to the target.

Debug is performed using 2 pins only instead of 5 required by the JTAG (JTAG pins could be re-use as GPIO with alternate function): the JTAG TMS and TCK pins are shared with SWDIO and SWCLK, respectively, and a specific sequence on the TMS pin is used to switch between JTAG-DP and SW-DP.

3.40 Embedded Trace Macrocell™

The Arm Embedded Trace Macrocell provides a greater visibility of the instruction and data flow inside the CPU core by streaming compressed data at a very high rate from the STM32F413xG/H through a small number of ETM pins to an external hardware trace port analyzer (TPA) device. The TPA is connected to a host computer using any high-speed channel available. Real-time instruction and data flow activity can be recorded and then formatted for display on the host computer that runs the debugger software. TPA hardware is commercially available from common development tool vendors.

The Embedded Trace Macrocell operates with third party debugger software tools.

4 Pinouts and pin description

4.1 WLCSP81 pinout description

Figure 11. STM32F413xG/H WLCSP81 pinout

	1	2	3	4	5	6	7	8	9
A	VDD	PC10	PA15	PD0	PB3	PB5	BOOT0	VSS	VDD
B	VSS	PA14	PA12	PC12	PB4	PB6	PB7	PDR_ON	VBAT
C	VCAP_2	PA13	PA11	PC11	PD2	PB8	PC1	PC13- ANTI_TAMP	PC14- OSC32_IN
D	PA10	PA9	PA8	PC7	PC6	PB9	PC2	VSS	PC15- OSC32_OUT
E	PC8	PC9	PB14	PB0	PA4	PA3	PC3	VDD	PH0 - OSC_IN
F	VDDUSB	PD9	PB12	PE13	PA6	BYPASS_ REG	VDDA	PC0	PH1 - OSC_OUT
G	PD10	PB13	PE14	PE10	PB1	PA5	PA0-WKUP	VREF+	NRST
H	PB15	VCAP_1	PB10	PE11	PB2	PC4	VSS	PA1	VSSA/VREF-
J	VDD	VSS	PE15	PE12	PE9	PC5	PA7	VDD	PA2

MSv39493V1

1. The above figure shows the package top view.

4.2 UFQFPN48 pinout description

Figure 12. STM32F413xG/H UFQFPN48 pinout

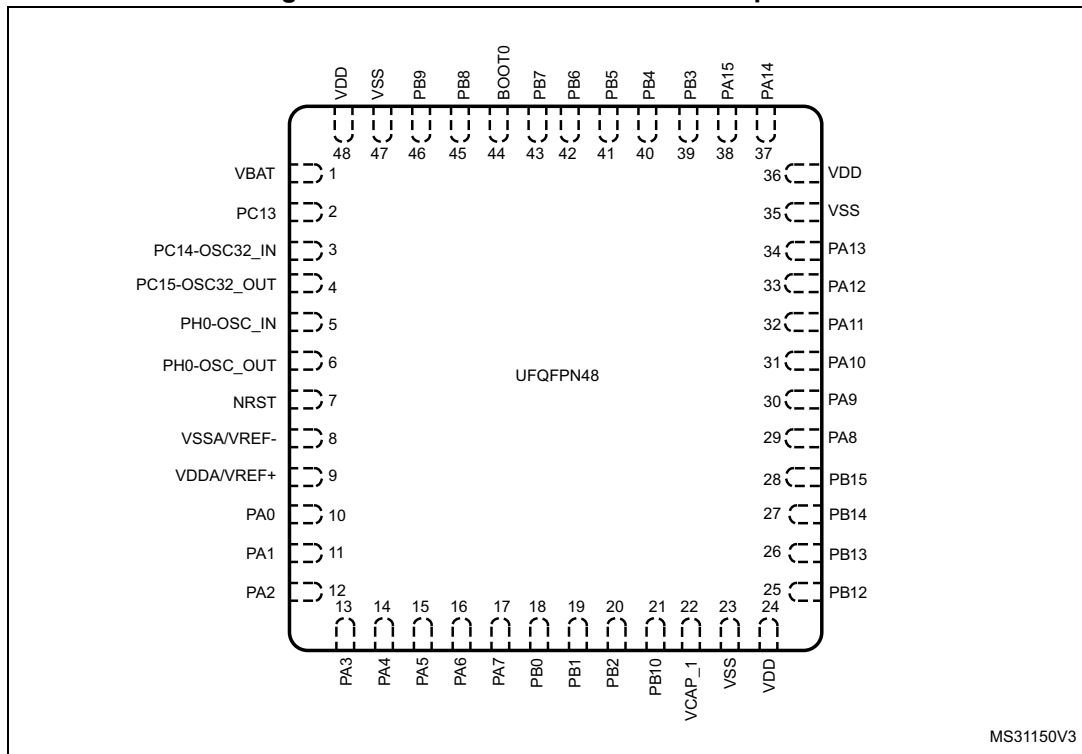

1. The above figure shows the package top view.

4.3 LQFP64 pinout description

Figure 13. STM32F413xG/H LQFP64 pinout

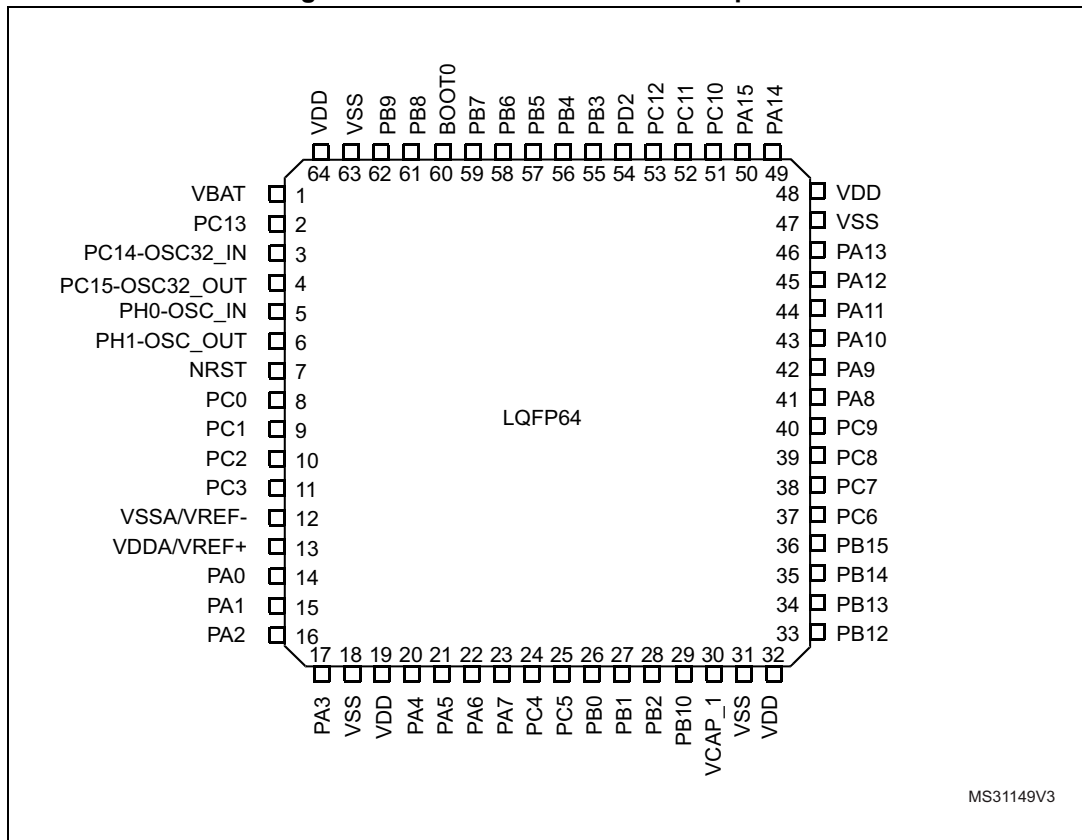

1. The above figure shows the package top view.

4.4 LQFP100 pinout description

Figure 14. STM32F413xG/H LQFP100 pinout

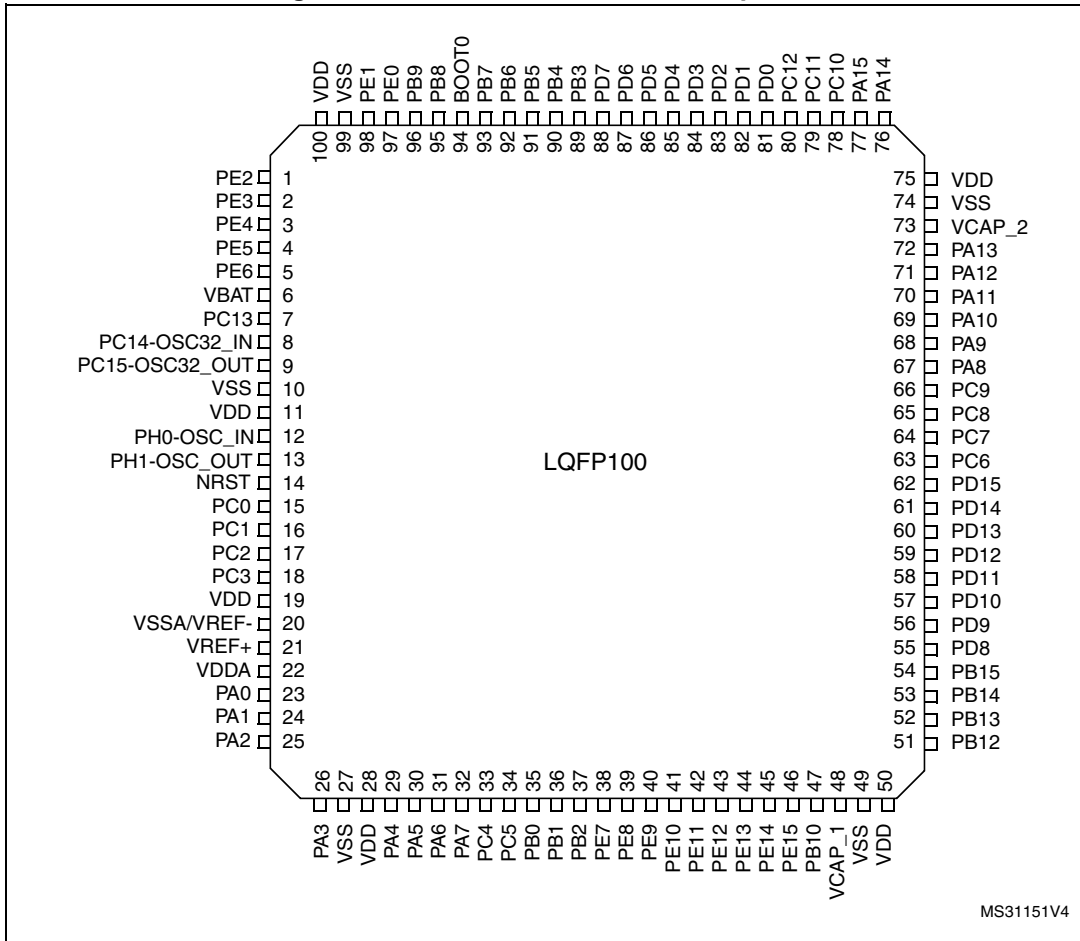

1. The above figure shows the package top view.

4.5 LQFP144 pinout description

Figure 15. STM32F413xG/H LQFP144 pinout

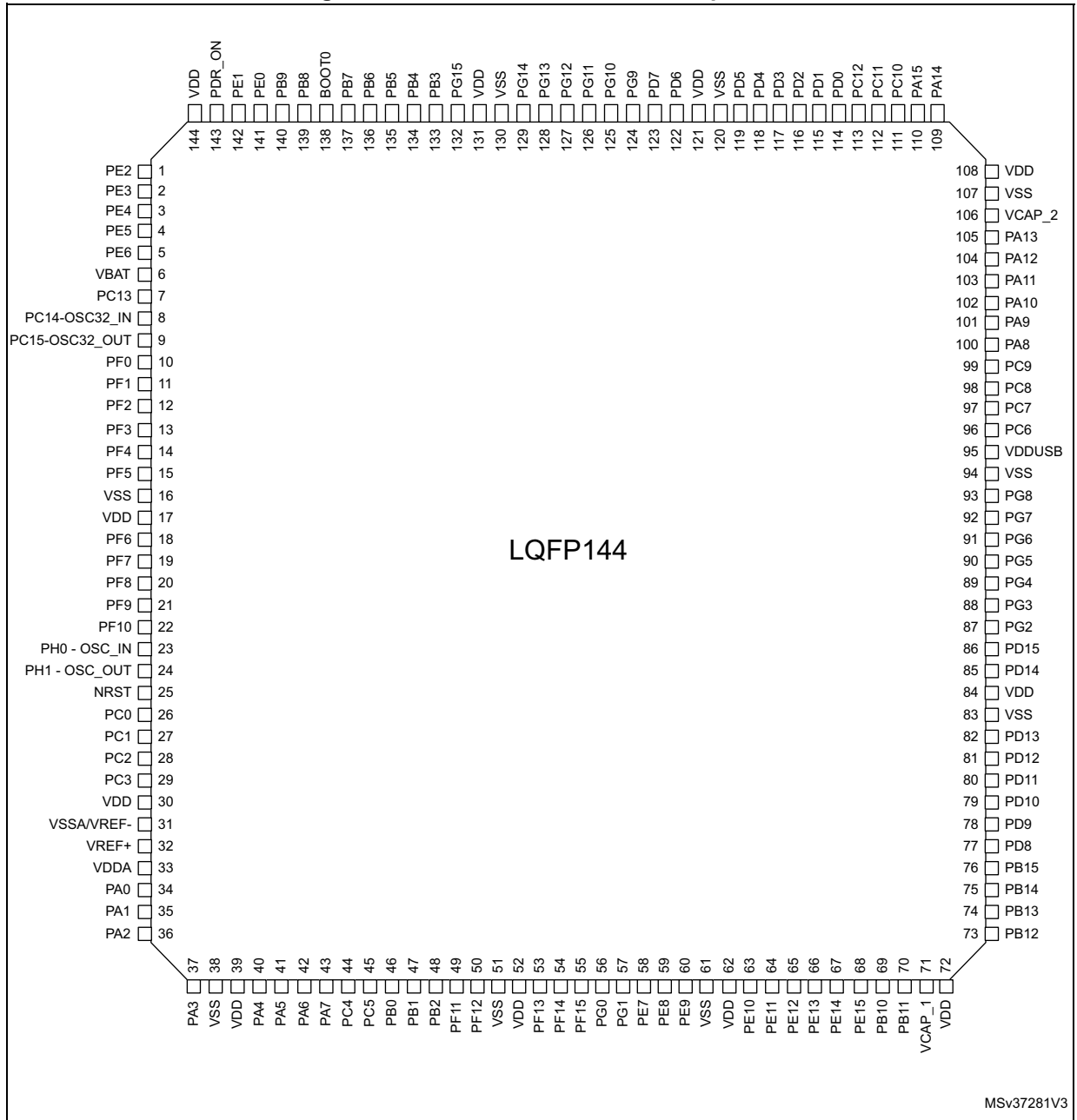

1. The above figure shows the package top view.

4.6 UFBGA100 pinout description

Figure 16. STM32F413xG/H UFBGA100 pinout

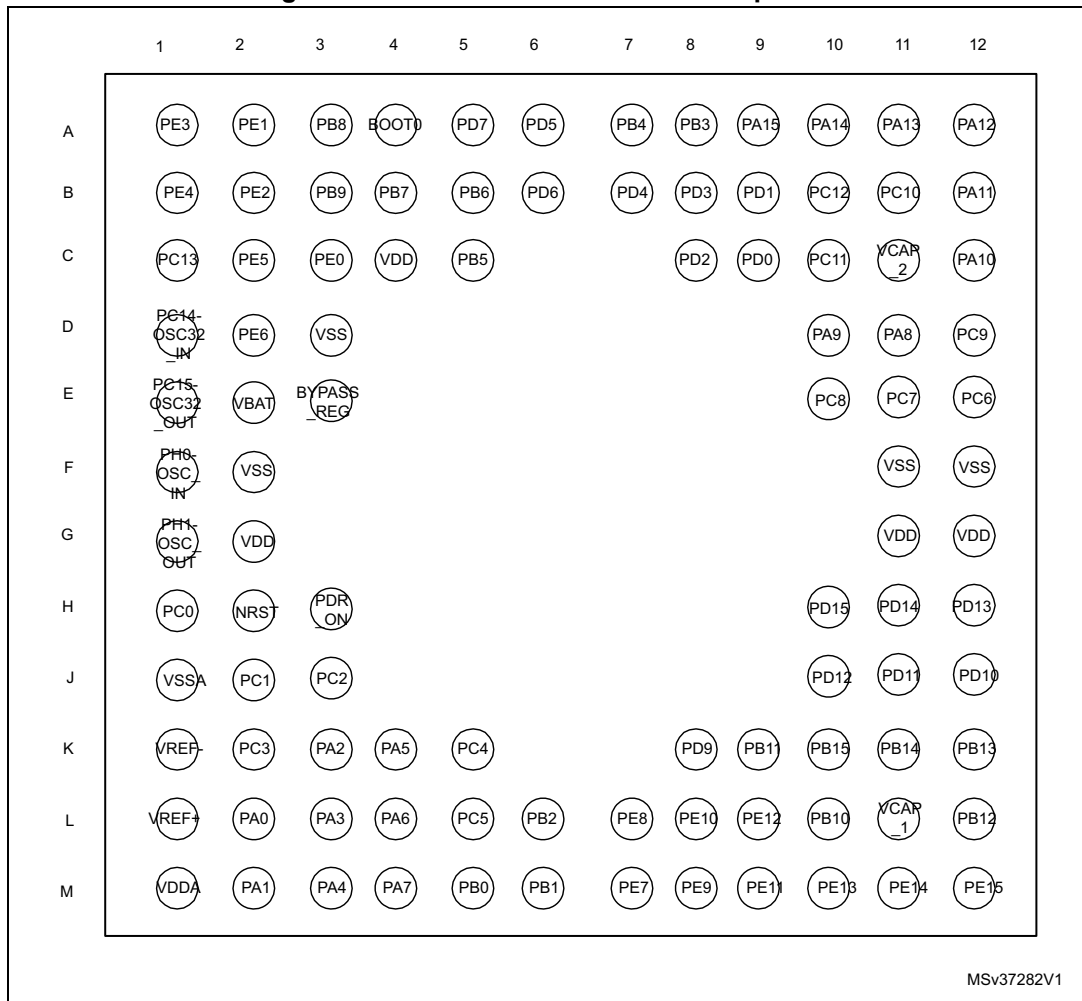

1. The above figure shows the package top view.

4.7 UFBGA144 pinout description

Figure 17. STM32F413xG/H UFBGA144 pinout

	1	2	3	4	5	6	7	8	9	10	11	12
A	PC13	PE3	PE2	PE1	PE0	PB4	PB3	PD6	PD7	PA15	PA14	PA13
B	PC14- OSC32_IN	PE4	PE5	PE6	PB9	PB5	PG15	PG12	PD5	PC11	PC10	PA12
C	PC15- OSC32_OUT	VBAT	PF0	PF1	PB8	PB6	PG14	PG11	PD4	PC12	VDDUSB	PA11
D	PH0 - OSC_IN	VSS	VDD	PF2	BOOT0	PB7	PG13	PG10	PD3	PD1	PA10	PA9
E	PH1 - OSC_OUT	PF3	PF4	PF5	PDR_ON	VSS	VSS	PG9	PD2	PD0	PC9	PA8
F	NRST	PF7	PF6	VDD	VDD	VDD	VDD	VDD	VDD	VDD	PC8	PC7
G	PF10	PF9	PF8	VSS	VDD	VDD	VDD	VSS	VCAP_2	VSS	PG8	PC6
H	PC0	PC1	PC2	PC3	BYPASS- REG	VSS	VCAP_1	PE11	PD11	PG7	PG6	PG5
J	VSSA	PA0	PA4	PC4	PB2	PG1	PE10	PE12	PD10	PG4	PG3	PG2
K	VREF-	PA1	PA5	PC5	PF13	PG0	PE9	PE13	PD9	PD13	PD14	PD15
L	VREF+	PA2	PA6	PB0	PF12	PF15	PE8	PE14	PD8	PD12	PB14	PB15
M	VDDA	PA3	PA7	PB1	PF11	PF14	PE7	PE15	PB10	PB11	PB12	PB13

MSv37283V2

1. The above figure shows the package top view.

4.8 Pins definition

Table 9. Legend/abbreviations used in the pinout table

Name	Abbreviation	Definition
Pin name		Unless otherwise specified in brackets below the pin name, the pin function during and after reset is the same as the actual pin name
Pin type	S	Supply pin
	I	Input only pin
	I/O	Input/ output pin
I/O structure	FT	5 V tolerant I/O
	FTf	5 V tolerant I/O, I2C FM+ option
	TC	Standard 3.3 V I/O
	TTa	3.3 V tolerant I/O directly connected to DAC
	B	Dedicated BOOT0 pin
	NRST	Bidirectional reset pin with embedded weak pull-up resistor
Notes		Unless otherwise specified by a note, all I/Os are set as floating inputs during and after reset

Table 9. Legend/abbreviations used in the pinout table (continued)

Name	Abbreviation	Definition
Alternate functions		Functions selected through GPIOx_AFR registers
Additional functions		Functions directly selected/enabled through peripheral registers

Table 10. STM32F413xG/H pin definition

Pin Number							Pin name (function after reset) ⁽¹⁾	Pin type	I/O structure	Notes	Alternate functions	Additional functions
UFQFPN48	LQFP64	WLCSP81	LQFP100	UFBGA100	UFBGA144	LQFP144						
-	-	NC	1	B2	A3	1	PE2	I/O	FT	(2)	TRACECLK, SPI4_SCK/I2S4_CK, SPI5_SCK/I2S5_CK, SAI1_MCLK_A, QUADSPI_BK1_IO2, UART10_RX, FSMC_A23, EVENTOUT	-
-	-	NC	2	A1	A2	2	PE3	I/O	FT	(2)	TRACED0, SAI1_SD_B, UART10_TX, FSMC_A19, EVENTOUT	-
-	-	NC	3	B1	B2	3	PE4	I/O	FT	(2)(3)	TRACED1, SPI4_NSS/I2S4_WS, SPI5_NSS/I2S5_WS, SAI1_SD_A, DFSDM1_DATIN3, FSMC_A20, EVENTOUT	-
-	-	NC	4	C2	B3	4	PE5	I/O	FT	(2)	TRACED2, TIM9_CH1, SPI4_MISO, SPI5_MISO, SAI1_SCK_A, DFSDM1_CKIN3, FSMC_A21, EVENTOUT	-
-	-	NC	5	D2	B4	5	PE6	I/O	FT	(2)(3)	TRACED3, TIM9_CH2, SPI4_MOSI/I2S4_SD, SPI5_MOSI/I2S5_SD, SAI1_FS_A, FSMC_A22, EVENTOUT	-
1	1	B9	6	E2	C2	6	VBAT	S	-	-	-	VBAT
2	2	C8	7	C1	A1	7	PC13- ANTI_TAMP	I/O	FT	(4)(5)	EVENTOUT	TAMP_1
3	3	C9	8	D1	B1	8	PC14- OSC32_IN	I/O	FT	(4)(5)(6)	EVENTOUT	OSC32_IN

Table 10. STM32F413xG/H pin definition (continued)

Pin Number							Pin name (function after reset) ⁽¹⁾	Pin type	I/O structure	Notes	Alternate functions	Additional functions
UQFPN48	LQFP64	WLCSP81	LQFP100	UFBGA100	UFBGA144	LQFP144						
4	4	D9	9	E1	C1	9	PC15-OSC32_OUT	I/O	FT	(4)(6)	EVENTOUT	OSC32_OUT
-	-	-	-	-	C3	10	PF0	I/O	FT	-	I2C2_SDA, FSMC_A0, EVENTOUT	-
-	-	-	-	-	C4	11	PF1	I/O	FT	-	I2C2_SCL, FSMC_A1, EVENTOUT	-
-	-	-	-	-	D4	12	PF2	I/O	FT	-	I2C2_SMBA, FSMC_A2, EVENTOUT	-
-	-	-	-	-	E2	13	PF3	I/O	FT	-	TIM5_CH1, FSMC_A3, EVENTOUT	-
-	-	-	-	-	E3	14	PF4	I/O	FT	-	TIM5_CH2, FSMC_A4, EVENTOUT	-
-	-	-	-	-	E4	15	PF5	I/O	FT	-	TIM5_CH3, FSMC_A5, EVENTOUT	-
-	-	D8	10	F2	D2	16	VSS	S	-	-	-	-
-	-	E8	11	G2	D3	17	VDD	S	-	-	-	-
-	-	-	-	-	F3	18	PF6	I/O	FT	-	TRACED0, TIM10_CH1, SAI1_SD_B, UART7_Rx, QUADSPI_BK1_IO3, EVENTOUT	-
-	-	-	-	-	F2	19	PF7	I/O	FT	-	TRACED1, TIM11_CH1, SAI1_MCLK_B, UART7_Tx, QUADSPI_BK1_IO2, EVENTOUT	-
-	-	-	-	-	G3	20	PF8	I/O	FT	-	SAI1_SCK_B, UART8_RX, TIM13_CH1, QUADSPI_BK1_IO0, EVENTOUT	-
-	-	-	-	-	G2	21	PF9	I/O	FT	-	SAI1_FS_B, UART8_TX, TIM14_CH1, QUADSPI_BK1_IO1, EVENTOUT	-
-	-	-	-	-	G1	22	PF10	I/O	FT	-	TIM1_ETR, TIM5_CH4, EVENTOUT	-
5	5	E9	12	F1	D1	23	PH0 - OSC_IN	I/O	FT	(6)	EVENTOUT	OSC_IN
6	6	F9	13	G1	E1	24	PH1 - OSC_OUT	I/O	FT	(6)	EVENTOUT	OSC_OUT

Table 10. STM32F413xG/H pin definition (continued)

Pin Number							Pin name (function after reset) ⁽¹⁾	Pin type	I/O structure	Notes	Alternate functions	Additional functions
UFQFPN48	LQFP64	WLCSP81	LQFP100	UFBGA100	UFBGA144	LQFP144						
7	7	G9	14	H2	F1	25	NRST	I/O	RST	-	-	NRST
-	8	F8	15	H1	H1	26	PC0	I/O	FT	-	LPTIM1_IN1, DFSDM2_CKIN4, SAI1_MCLK_B, EVENTOUT	ADC1_IN10, WKUP2
-	9	C7	16	J2	H2	27	PC1	I/O	FT	-	LPTIM1_OUT, DFSDM2_DATIN4, SAI1_SD_B, EVENTOUT	ADC1_IN11, WKUP3
-	10	D7	17	J3	H3	28	PC2	I/O	FT	-	LPTIM1_IN2, DFSDM2_DATIN7, SPI2_MISO, I2S2ext_SD, SAI1_SCK_B, DFSDM1_CKOUT, FSMC_NWE, EVENTOUT	ADC1_IN12
-	11	E7	18	K2	H4	29	PC3	I/O	FT	-	LPTIM1_ETR, DFSDM2_CKIN7, SPI2_MOSI/I2S2_SD, SAI1_FS_B, FSMC_A0, EVENTOUT	ADC1_IN13
-	-	-	19	-	-	30	VDD	S	-	-	-	-
8	12	H9	20	J1	J1	31	VSSA	S	-	-	-	-
-	-	-	-	K1	K1	-	VREF-	S	-	-	-	-
-	-	G8	21	L1	L1	32	VREF+	S	-	-	-	-
9	13	F7	22	M1	M1	33	VDDA	S	-	-	-	-
10	14	G7	23	L2	J2	34	PA0	I/O	FT	-	TIM2_CH1/TIM2_ETR, TIM5_CH1, TIM8_ETR, USART2_CTS, UART4_TX, EVENTOUT	ADC1_IN0, WKUP1
11	15	H8	24	M2	K2	35	PA1	I/O	FT	-	TIM2_CH2, TIM5_CH2, SPI4_MOSI/I2S4_SD, USART2_RTS, UART4_RX, QUADSPI_BK1_IO3, EVENTOUT	ADC1_IN1
12	16	J9	25	K3	L2	36	PA2	I/O	FT	-	TIM2_CH3, TIM5_CH3, TIM9_CH1, I2S2_CKIN, USART2_TX, FSMC_D4/FSMC_DA4, EVENTOUT	ADC1_IN2

Table 10. STM32F413xG/H pin definition (continued)

Pin Number							Pin name (function after reset) ⁽¹⁾	Pin type	I/O structure	Notes	Alternate functions	Additional functions
UQFPN48	LQFP64	WLCSP81	LQFP100	UFBGA100	UFBGA144	LQFP144						
13	17	E6	26	L3	M2	37	PA3	I/O	FT	-	TIM2_CH4, TIM5_CH4, TIM9_CH2, I2S2_MCK, USART2_RX, SAI1_SD_B, FSMC_D5/FSMC_DA5, EVENTOUT	ADC1_IN3
-	18	H7	27	-	-	38	VSS	S	-	-	-	-
-	-	F6	-	E3	H5	-	BYPASS_REG	I	FT	-	-	-
-	19	J8	28	-	F4	39	VDD	S	-	-	-	-
14	20	E5	29	M3	J3	40	PA4	I/O	TTa	-	SPI1_NSS/I2S1_WS, SPI3_NSS/I2S3_WS, USART2_CK, DFSDM1_DATIN1, FSMC_D6/FSMC_DA6, EVENTOUT	ADC1_IN4, DAC_OUT1
15	21	G6	30	K4	K3	41	PA5	I/O	TTa	-	TIM2_CH1/TIM2_ETR, TIM8_CH1N, SPI1_SCK/I2S1_CK, DFSDM1_CKIN1, FSMC_D7/FSMC_DA7, EVENTOUT	ADC1_IN5, DAC_OUT2
16	22	F5	31	L4	L3	42	PA6	I/O	FT	-	TIM1_BKIN, TIM3_CH1, TIM8_BKIN, SPI1_MISO, I2S2_MCK, DFSDM2_CKIN1, TIM13_CH1, QUADSPI_BK2_IO0, SDIO_CMD, EVENTOUT	ADC1_IN6
17	23	J7	32	M4	M3	43	PA7	I/O	FT	-	TIM1_CH1N, TIM3_CH2, TIM8_CH1N, SPI1_MOSI/I2S1_SD, DFSDM2_DATIN1, TIM14_CH1, QUADSPI_BK2_IO1, EVENTOUT	ADC1_IN7
-	24	H6	33	K5	J4	44	PC4	I/O	FT	-	DFSDM2_CKIN2, I2S1_MCK, QUADSPI_BK2_IO2, FSMC_NE4, EVENTOUT	ADC1_IN14

Table 10. STM32F413xG/H pin definition (continued)

Pin Number							Pin name (function after reset) ⁽¹⁾	Pin type	I/O structure	Notes	Alternate functions	Additional functions
UQFPN48	LQFP64	WLCSP81	LQFP100	UFBGA100	UFBGA144	LQFP144						
-	25	J6	34	L5	K4	45	PC5	I/O	FT	-	DFSDM2_DATIN2, I2CFMP1_SMBA, USART3_RX, QUADSPI_BK2_IO3, FSMC_NOE, EVENTOUT	ADC1_IN15
18	26	E4	35	M5	L4	46	PB0	I/O	FT	-	TIM1_CH2N, TIM3_CH3, TIM8_CH2N, SPI5_SCK/I2S5_CK, EVENTOUT	ADC1_IN8
19	27	G5	36	M6	M4	47	PB1	I/O	FT	-	TIM1_CH3N, TIM3_CH4, TIM8_CH3N, SPI5_NSS/I2S5_WS, DFSDM1_DATIN0, QUADSPI_CLK, EVENTOUT	ADC1_IN9
20	28	H5	37	L6	J5	48	PB2	I/O	FT	-	LPTIM1_OUT, DFSDM1_CKIN0, QUADSPI_CLK, EVENTOUT	BOOT1
-	-	-	-	-	M5	49	PF11	I/O	FT	-	TIM8_ETR, EVENTOUT	-
-	-	-	-	-	L5	50	PF12	I/O	FT	-	TIM8_BKIN, FSMC_A6, EVENTOUT	-
-	-	-	-	-	G4	51	VSS	S	-	-	-	-
-	-	-	-	-	G5	52	VDD	S	-	-	-	-
-	-	-	-	-	K5	53	PF13	I/O	FT	-	I2CFMP1_SMBA, FSMC_A7, EVENTOUT	-
-	-	-	-	-	M6	54	PF14	I/O	FTf	-	I2CFMP1_SCL, FSMC_A8, EVENTOUT	-
-	-	-	-	-	L6	55	PF15	I/O	FTf	-	I2CFMP1_SDA, FSMC_A9, EVENTOUT	-
-	-	-	-	-	K6	56	PG0	I/O	FT	-	CAN1_RX, UART9_RX, FSMC_A10, EVENTOUT	-
-	-	-	-	-	J6	57	PG1	I/O	FT	-	CAN1_TX, UART9_TX, FSMC_A11, EVENTOUT	-

Table 10. STM32F413xG/H pin definition (continued)

Pin Number							Pin name (function after reset) ⁽¹⁾	Pin type	I/O structure	Notes	Alternate functions	Additional functions
UFQFPN48	LQFP64	WLCSP81	LQFP100	UFBGA100	UFBGA144	LQFP144						
-	-	NC	38	M7	M7	58	PE7	I/O	FT	(2)	TIM1_ETR, DFSDM1_DATIN2, UART7_Rx, QUADSPI_BK2_IO0, FSMC_D4/FSMC_DA4, EVENTOUT	-
-	-	NC	39	L7	L7	59	PE8	I/O	FT	(2)	TIM1_CH1N, DFSDM1_CKIN2, UART7_Tx, QUADSPI_BK2_IO1, FSMC_D5/FSMC_DA5, EVENTOUT	-
-	-	J5	40	M8	K7	60	PE9	I/O	FT	-	TIM1_CH1, DFSDM1_CKOUT, QUADSPI_BK2_IO2, FSMC_D6/FSMC_DA6, EVENTOUT	-
-	-	-	-	-	H6	61	VSS	S	-	-	-	-
-	-	-	-	-	G6	62	VDD	S	-	-	-	-
-	-	G4	41	L8	J7	63	PE10	I/O	FT	-	TIM1_CH2N, DFSDM2_DATIN0, QUADSPI_BK2_IO3, FSMC_D7/FSMC_DA7, EVENTOUT	-
-	-	H4	42	M9	H8	64	PE11	I/O	FT	-	TIM1_CH2, DFSDM2_CKIN0, SPI4_NSS/I2S4_WS, SPI5_NSS/I2S5_WS, FSMC_D8/FSMC_DA8, EVENTOUT	-
-	-	J4	43	L9	J8	65	PE12	I/O	FT	-	TIM1_CH3N, DFSDM2_DATIN7, SPI4_SCK/I2S4_CK, SPI5_SCK/I2S5_CK, FSMC_D9/FSMC_DA9, EVENTOUT	-
-	-	F4	44	M10	K8	66	PE13	I/O	FT	-	TIM1_CH3, DFSDM2_CKIN7, SPI4_MISO, SPI5_MISO, FSMC_D10/FSMC_DA10, EVENTOUT	-

Table 10. STM32F413xG/H pin definition (continued)

Pin Number							Pin name (function after reset) ⁽¹⁾	Pin type	I/O structure	Notes	Alternate functions	Additional functions
UFQFPN48	LQFP64	WLCSP81	LQFP100	UFBGA100	UFBGA144	LQFP144						
-	-	G3	45	M11	L8	67	PE14	I/O	FT	-	TIM1_CH4, SPI4_MOSI/I2S4_SD, SPI5_MOSI/I2S5_SD, DFSDM2_DATIN1, FSMC_D11/FSMC_DA1 1, EVENTOUT	-
-	-	J3	46	M12	M8	68	PE15	I/O	FT	-	TIM1_BKIN, DFSDM2_CKIN1, FSMC_D12/FSMC_DA1 2, EVENTOUT	-
21	29	H3	47	L10	M9	69	PB10	I/O	FTf	-	TIM2_CH3, I2C2_SCL, SPI2_SCK/I2S2_CK, I2S3_MCK, USART3_TX, I2CFMP1_SCL, DFSDM2_CKOUT, SDIO_D7, EVENTOUT	-
-	-	NC	-	K9	M10	70	PB11	I/O	FT	-	TIM2_CH4, I2C2_SDA, I2S2_CKIN, USART3_RX, EVENTOUT	-
22	30	H2	48	L11	H7	71	VCAP_1	S	-	-	-	-
23	31	J2	49	F12	-	-	VSS	S	-	-	-	-
24	32	J1	50	G12	G7	72	VDD	S	-	-	-	-
25	33	F3	51	L12	M11	73	PB12	I/O	FT	-	TIM1_BKIN, I2C2_SMBA, SPI2_NSS/I2S2_WS, SPI4_NSS/I2S4_WS, SPI3_SCK/I2S3_CK, USART3_CK, CAN2_RX, DFSDM1_DATIN1, UART5_RX, FSMC_D13/FSMC_DA1 3, EVENTOUT	-
26	34	G2	52	K12	M12	74	PB13	I/O	FT	-	TIM1_CH1N, I2CFMP1_SMBA, SPI2_SCK/I2S2_CK, SPI4_SCK/I2S4_CK, USART3_CTS, CAN2_TX, DFSDM1_CKIN1, UART5_TX, EVENTOUT	-



Table 10. STM32F413xG/H pin definition (continued)

Pin Number							Pin name (function after reset) ⁽¹⁾	Pin type	I/O structure	Notes	Alternate functions	Additional functions
UQFPN48	LQFP64	WLCSP81	LQFP100	UFBGA100	UFBGA144	LQFP144						
27	35	E3	53	K11	L11	75	PB14	I/O	FTf	-	TIM1_CH2N, TIM8_CH2N, I2CFMP1_SDA, SPI2_MISO, I2S2ext_SD, USART3_RTS, DFSDM1_DATIN2, TIM12_CH1, FSMC_D0/FSMC_DA0, SDIO_D6, EVENTOUT	-
28	36	H1	54	K10	L12	76	PB15	I/O	FTf	-	RTC_REFIN, TIM1_CH3N, TIM8_CH3N, I2CFMP1_SCL, SPI2_MOSI/I2S2_SD, DFSDM1_CKIN2, TIM12_CH2, SDIO_CK, EVENTOUT	-
-	-	NC	55	-	L9	77	PD8	I/O	FT	(2)	USART3_TX, FSMC_D13/FSMC_DA13, EVENTOUT	-
-	-	F2	56	K8	K9	78	PD9	I/O	FT	-	USART3_RX, FSMC_D14/FSMC_DA14, EVENTOUT	-
-	-	G1	57	J12	J9	79	PD10	I/O	FT	(7)	USART3_CK, UART4_TX, FSMC_D15/FSMC_DA15, EVENTOUT	-
-	-	NC	58	J11	H9	80	PD11	I/O	FT	(2)	DFSDM2_DATIN2, I2CFMP1_SMBA, USART3_CTS, QUADSPI_BK1_IO0, FSMC_A16, EVENTOUT	-
-	-	NC	59	J10	L10	81	PD12	I/O	FTf	(2)	TIM4_CH1, DFSDM2_CKIN2, I2CFMP1_SCL, USART3_RTS, QUADSPI_BK1_IO1, FSMC_A17, EVENTOUT	-
-	-	NC	60	H12	K10	82	PD13	I/O	FTf	(2)	TIM4_CH2, I2CFMP1_SDA, QUADSPI_BK1_IO3, FSMC_A18, EVENTOUT	-
-	-	-	-	-	G8	83	VSS	S	-	-	-	-

Table 10. STM32F413xG/H pin definition (continued)

Pin Number							Pin name (function after reset) ⁽¹⁾	Pin type	I/O structure	Notes	Alternate functions	Additional functions
UFQFPN48	LQFP64	WLCSP81	LQFP100	UFBGA100	UFBGA144	LQFP144						
-	-	-	-	-	F8	84	VDD	S	-	-	-	-
-	-	NC	61	H11	K11	85	PD14	I/O	FTf	(2)	TIM4_CH3, I2CFMP1_SCL, DFSDM2_CKIN0, UART9_RX, FSMC_D0/FSMC_DA0, EVENTOUT	-
-	-	NC	62	H10	K12	86	PD15	I/O	FTf	(2)	TIM4_CH4, I2CFMP1_SDA, DFSDM2_DATIN0, UART9_TX, FSMC_D1/FSMC_DA1, EVENTOUT	-
-	-	-	-	-	J12	87	PG2	I/O	FT	-	FSMC_A12, EVENTOUT	-
-	-	-	-	-	J11	88	PG3	I/O	FT	-	FSMC_A13, EVENTOUT	-
-	-	-	-	-	J10	89	PG4	I/O	FT	-	FSMC_A14, EVENTOUT	-
-	-	-	-	-	H12	90	PG5	I/O	FT	-	FSMC_A15, EVENTOUT	-
-	-	-	-	-	H11	91	PG6	I/O	FT	-	QUADSPI_BK1_NCS, EVENTOUT	-
-	-	-	-	-	H10	92	PG7	I/O	FT	-	USART6_CK, EVENTOUT	-
-	-	-	-	-	G11	93	PG8	I/O	FT	-	USART6_RTS, EVENTOUT	-
-	-	-	-	-	-	94	VSS	S	-	-	-	-
-	-	-	-	-	F10	-	VDD	S	-	-	-	-
-	-	F1	-	-	C11	95	VDDUSB	S	-	-	-	-
-	37	D5	63	E12	G12	96	PC6	I/O	FTf	-	TIM3_CH1, TIM8_CH1, I2CFMP1_SCL, I2S2_MCK, DFSDM1_CKIN3, DFSDM2_DATIN6, USART6_TX, FSMC_D1/FSMC_DA1, SDIO_D6, EVENTOUT	-

Table 10. STM32F413xG/H pin definition (continued)

Pin Number							Pin name (function after reset) ⁽¹⁾	Pin type	I/O structure	Notes	Alternate functions	Additional functions
UQFPN48	LQFP64	WLCSP81	LQFP100	UFBGA100	UFBGA144	LQFP144						
-	38	D4	64	E11	F12	97	PC7	I/O	FTf	-	TIM3_CH2, TIM8_CH2, I2CFMP1_SDA, SPI2_SCK/I2S2_CK, I2S3_MCK, DFSDM2_CKIN6, USART6_RX, DFSDM1_DATIN3, SDIO_D7, EVENTOUT	-
-	39	E1	65	E10	F11	98	PC8	I/O	FT	-	TIM3_CH3, TIM8_CH3, DFSDM2_CKIN3, USART6_CK, QUADSPI_BK1_IO2, SDIO_D0, EVENTOUT	-
-	40	E2	66	D12	E11	99	PC9	I/O	FT	-	MCO_2, TIM3_CH4, TIM8_CH4, I2C3_SDA, I2S2_CKIN, DFSDM2_DATIN3, QUADSPI_BK1_IO0, SDIO_D1, EVENTOUT	-
29	41	D3	67	D11	E12	100	PA8	I/O	FT	-	MCO_1, TIM1_CH1, I2C3_SCL, DFSDM1_CKOUT, USART1_CK, UART7_RX, USB_FS_SOF, CAN3_RX, SDIO_D1, EVENTOUT	-
30	42	D2	68	D10	D12	101	PA9	I/O	FT	-	TIM1_CH2, DFSDM2_CKIN3, I2C3_SMBA, SPI2_SCK/I2S2_CK, USART1_TX, USB_FS_VBUS, SDIO_D2, EVENTOUT	-
31	43	D1	69	C12	D11	102	PA10	I/O	FT	-	TIM1_CH3, DFSDM2_DATIN3, SPI2_MOSI/I2S2_SD, SPI5_MOSI/I2S5_SD, USART1_RX, USB_FS_ID, EVENTOUT	-

Table 10. STM32F413xG/H pin definition (continued)

Pin Number							Pin name (function after reset) ⁽¹⁾	Pin type	I/O structure	Notes	Alternate functions	Additional functions
UQFPN48	LQFP64	WLCSP81	LQFP100	UFBGA100	UFBGA144	LQFP144						
32	44	C3	70	B12	C12	103	PA11	I/O	FT	-	TIM1_CH4, DFSDM2_CKIN5, SPI2_NSS/I2S2_WS, SPI4_MISO, USART1_CTS, USART6_TX, CAN1_RX, USB_FS_DM, UART4_RX, EVENTOUT	-
33	45	B3	71	A12	B12	104	PA12	I/O	FT	-	TIM1_ETR, DFSDM2_DATIN5, SPI2_MISO, SPI5_MISO, USART1_RTS, USART6_RX, CAN1_TX, USB_FS_DP, UART4_TX, EVENTOUT	-
34	46	C2	72	A11	A12	105	PA13	I/O	FT	-	JTMS-SWDIO, EVENTOUT	-
-	-	C1	73	C11	G9	106	VCAP_2	S	-	-	-	-
35	47	B1	74	F11	G10	107	VSS	S	-	-	-	-
-	48	-	75	G11	-	-	VDD	S	-	-	-	-
36	-	A1	-	-	F9	108	VDD	S	-	-	-	-
37	49	B2	76	A10	A11	109	PA14	I/O	FT	-	JTCK-SWCLK, EVENTOUT	-
38	50	A3	77	A9	A10	110	PA15	I/O	FT	-	JTDI, TIM2_CH1/TIM2_ETR, SPI1_NSS/I2S1_WS, SPI3_NSS/I2S3_WS, USART1_TX, UART7_TX, SAI1_MCLK_A, CAN3_TX, EVENTOUT	-
-	51	A2	78	B11	B11	111	PC10	I/O	FT	-	DFSDM2_CKIN5, SPI3_SCK/I2S3_CK, USART3_TX, QUADSPI_BK1_IO1, SDIO_D2, EVENTOUT	-

Table 10. STM32F413xG/H pin definition (continued)

Pin Number							Pin name (function after reset) ⁽¹⁾	Pin type	I/O structure	Notes	Alternate functions	Additional functions
UFQFPN48	LQFP64	WLCSP81	LQFP100	UFBGA100	UFBGA144	LQFP144						
-	52	C4	79	C10	B10	112	PC11	I/O	FT	-	DFSDM2_DATIN5, I2S3ext_SD, SPI3_MISO, USART3_RX, UART4_RX, QUADSPI_BK2_NCS, FSMC_D2/FSMC_DA2, SDIO_D3, EVENTOUT	-
-	53	B4	80	B10	C10	113	PC12	I/O	FT	-	SPI3_MOSI/I2S3_SD, USART3_CK, UART5_TX, FSMC_D3/FSMC_DA3, SDIO_CK, EVENTOUT	-
-	-	A4	81	C9	E10	114	PD0	I/O	FT	-	DFSDM2_CKIN6, CAN1_RX, UART4_RX, FSMC_D2/FSMC_DA2, EVENTOUT	-
-	-	NC	82	B9	D10	115	PD1	I/O	FT	(2)	DFSDM2_DATIN6, CAN1_TX, UART4_TX, FSMC_D3/FSMC_DA3, EVENTOUT	-
-	54	C5	83	C8	E9	116	PD2	I/O	FT	-	TIM3_ETR, DFSDM2_CKOUT, UART5_RX, FSMC_NWE, SDIO_CMD, EVENTOUT	-
-	-	NC	84	B8	D9	117	PD3	I/O	FT	(2)	TRACED1, SPI2_SCK/I2S2_CK, DFSDM1_DATIN0, USART2_CTS, QUADSPI_CLK, FSMC_CLK, EVENTOUT	-
-	-	NC	85	B7	C9	118	PD4	I/O	FT	(2)	DFSDM1_CKIN0, USART2_RTS, FSMC_NOE, EVENTOUT	-
-	-	NC	86	A6	B9	119	PD5	I/O	FT	(2)	DFSDM2_CKOUT, USART2_TX, FSMC_NWE, EVENTOUT	-
-	-	-	-	-	E7	120	VSS	S	-	-	-	-
-	-	-	-	-	F7	121	VDD	S	-	-	-	-

Table 10. STM32F413xG/H pin definition (continued)

Pin Number							Pin name (function after reset) ⁽¹⁾	Pin type	I/O structure	Notes	Alternate functions	Additional functions
UQFPN48	LQFP64	WLCSP81	LQFP100	UFBGA100	UFBGA144	LQFP144						
-	-	NC	87	B6	A8	122	PD6	I/O	FT	(2)	SPI3_MOSI/I2S3_SD, DFSDM1_DATIN1, USART2_RX, FSMC_NWAIT, EVENTOUT	-
-	-	NC	88	A5	A9	123	PD7	I/O	FT	(2)	DFSDM1_CKIN1, USART2_CK, FSMC_NE1, EVENTOUT	-
-	-	-	-	-	E8	124	PG9	I/O	FT	-	USART6_RX, QUADSPI_BK2_IO2, FSMC_NE2, EVENTOUT	-
-	-	-	-	-	D8	125	PG10	I/O	FT	-	FSMC_NE3, EVENTOUT	-
-	-	-	-	-	C8	126	PG11	I/O	FT	-	CAN2_RX, UART10_RX, EVENTOUT	-
-	-	-	-	-	B8	127	PG12	I/O	FT	-	USART6_RTS, CAN2_TX, UART10_TX, FSMC_NE4, EVENTOUT	-
-	-	-	-	-	D7	128	PG13	I/O	FT	-	TRACED2, USART6_CTS, FSMC_A24, EVENTOUT	-
-	-	-	-	-	C7	129	PG14	I/O	FT	-	TRACED3, USART6_TX, QUADSPI_BK2_IO3, FSMC_A25, EVENTOUT	-
-	-	-	-	-	-	130	VSS	S	-	-	-	-
-	-	-	-	-	F6	131	VDD	S	-	-	-	-
-	-	-	-	-	B7	132	PG15	I/O	FT	-	USART6_CTS, EVENTOUT	-
39	55	A5	89	A8	A7	133	PB3	I/O	FTf	-	JTDO-SWO, TIM2_CH2, I2CFMP1_SDA, SPI1_SCK/I2S1_CK, SPI3_SCK/I2S3_CK, USART1_RX, UART7_RX, I2C2_SDA, SAI1_SD_A, CAN3_RX, EVENTOUT	-

Table 10. STM32F413xG/H pin definition (continued)

Pin Number							Pin name (function after reset) ⁽¹⁾	Pin type	I/O structure	Notes	Alternate functions	Additional functions
UQFPN48	LQFP64	WLCSP81	LQFP100	UFBGA100	UFBGA144	LQFP144						
40	56	B5	90	A7	A6	134	PB4	I/O	FT	-	JTRST, TIM3_CH1, SPI1_MISO, SPI3_MISO, I2S3ext_SD, UART7_TX, I2C3_SDA, SAI1_SCK_A, CAN3_TX, SDIO_D0, EVENTOUT	-
41	57	A6	91	C5	B6	135	PB5	I/O	FT	-	LPTIM1_IN1, TIM3_CH2, I2C1_SMBA, SPI1_MOSI/I2S1_SD, SPI3_MOSI/I2S3_SD, CAN2_RX, SAI1_FS_A, UART5_RX, SDIO_D3, EVENTOUT	-
42	58	B6	92	B5	C6	136	PB6	I/O	FT	-	LPTIM1_ETR, TIM4_CH1, I2C1_SCL, DFSDM2_CKIN7, USART1_TX, CAN2_TX, QUADSPI_BK1_NCS, UART5_TX, SDIO_D0, EVENTOUT	-
43	59	B7	93	B4	D6	137	PB7	I/O	FT	-	LPTIM1_IN2, TIM4_CH2, I2C1_SDA, DFSDM2_DATIN7, USART1_RX, FSMC_NL, EVENTOUT	-
44	60	A7	94	A4	D5	138	BOOT0	I	B	-	-	VPP
45	61	C6	95	A3	C5	139	PB8	I/O	FT	-	LPTIM1_OUT, TIM4_CH3, TIM10_CH1, I2C1_SCL, SPI5_MOSI/I2S5_SD, DFSDM2_CKIN1, CAN1_RX, I2C3_SDA, UART5_RX, SDIO_D4, EVENTOUT	-
46	62	D6	96	B3	B5	140	PB9	I/O	FT	-	TIM4_CH4, TIM11_CH1, I2C1_SDA, SPI2_NSS/I2S2_WS, DFSDM2_DATIN1, CAN1_TX, I2C2_SDA, UART5_TX, SDIO_D5, EVENTOUT	-

Table 10. STM32F413xG/H pin definition (continued)

Pin Number							Pin name (function after reset) ⁽¹⁾	Pin type	I/O structure	Notes	Alternate functions	Additional functions
UQFPN48	LQFP64	WLCSP81	LQFP100	UFBGA100	UFBGA144	LQFP144						
-	-	NC	97	C3	A5	141	PE0	I/O	FT	(2)	TIM4_ETR, DFSDM2_CKIN4, UART8_Rx, FSMC_NBL0, EVENTOUT	-
-	-	NC	98	A2	A4	142	PE1	I/O	FT	(2)	DFSDM2_DATIN4, UART8_Tx, FSMC_NBL1, EVENTOUT	-
47	63	A8	99	D3	E6	-	VSS	S	-	-	-	-
-	-	B8	-	H3	E5	143	PDR_ON	I	FT	-	-	-
48	64	A9	100	C4	F5	144	VDD	S	-	-	-	-

- Function availability depends on the chosen device.
- NC (Not Connected) pins are not bonded. They must be configured by software to output push-pull and forced to 0 in the output data register to avoid extra power consumption in low power mode.
- Compatibility issue on alternate function pin PE4 SAI1_SD_A and PE6 SAI1_FS_A: Pins have been swapped versus other MCUs supporting those alternate SAI functions on those pins
- PC13, PC14 and PC15 are supplied through the power switch. Since the switch only sinks a limited amount of current (3 mA), the use of GPIOs PC13 to PC15 in output mode is limited:
 - The speed should not exceed 2 MHz with a maximum load of 30 pF.
 - These I/Os must not be used as a current source (e.g. to drive an LED).
- Main function after the first backup domain power-up. Later on, it depends on the contents of the RTC registers even after reset (because these registers are not reset by the main reset). For details on how to manage these I/Os, refer to the RTC register description sections in the STM32F413/423 reference manual.
- FT = 5 V tolerant except when in analog mode or oscillator mode (for PC14, PC15, PH0 and PH1).
- Incompatibility issue on alternate function with other MCUs supporting UART4: UART4_TX wrongly mapped to PD10 instead of PC10

Table 11. FSMC pin definition

Pins	FSMC		64 pins	81 pins	100 pins	144 pins
	LCD/NOR/ PSRAM/SRAM	NOR/PSRAM Mux				
PE2	A23	A23	-	-	Yes	Yes
PE3	A19	A19	-	-	Yes	Yes
PE4	A20	A20	-	-	Yes	Yes
PE5	A21	A21	-	-	Yes	Yes
PE6	A22	A22	-	-	Yes	Yes
PF0	A0	-	-	-	-	Yes



Table 11. FSMC pin definition (continued)

Pins	FSMC		64 pins	81 pins	100 pins	144 pins
	LCD/NOR/ PSRAM/SRAM	NOR/PSRAM Mux				
PF1	A1	-	-	-	-	Yes
PF2	A2	-	-	-	-	Yes
PF3	A3	-	-	-	-	Yes
PF4	A4	-	-	-	-	Yes
PF5	A5	-	-	-	-	Yes
PC2	NWE	NWE	Yes	Yes	Yes	Yes
PC3	A0	-	Yes	Yes	Yes	Yes
PA2	D4	DA4	Yes	Yes	Yes	Yes
PA3	D5	DA5	Yes	Yes	Yes	Yes
PA4	D6	DA6	Yes	Yes	Yes	Yes
PA5	D7	DA7	Yes	Yes	Yes	Yes
PC4	NE4	NE4	Yes	Yes	Yes	Yes
PC5	NOE	NOE	Yes	Yes	Yes	Yes
PF12	A6	-	-	-	-	Yes
PF13	A7	-	-	-	-	Yes
PF14	A8	-	-	-	-	Yes
PF15	A9	-	-	-	-	Yes
PG0	A10	-	-	-	-	Yes
PG1	A11	-	-	-	-	Yes
PE7	D4	DA4	-	-	Yes	Yes
PE8	D5	DA5	-	-	Yes	Yes
PE9	D6	DA6	-	Yes	Yes	Yes
PE10	D7	DA7	-	Yes	Yes	Yes
PE11	D8	DA8	-	Yes	Yes	Yes
PE12	D9	DA9	-	Yes	Yes	Yes
PE13	D10	DA10	-	Yes	Yes	Yes
PE14	D11	DA11	-	Yes	Yes	Yes
PE15	D12	DA12	-	Yes	Yes	Yes
PB12	D13	DA13	Yes	Yes	Yes	Yes
PB14	D0	DA0	Yes	Yes	Yes	Yes
PD8	D13	DA13	-	-	-	Yes
PD9	D14	DA14	-	Yes	Yes	Yes
PD10	D15	DA15	-	Yes	Yes	Yes

Table 11. FSMC pin definition (continued)

Pins	FSMC		64 pins	81 pins	100 pins	144 pins
	LCD/NOR/ PSRAM/SRAM	NOR/PSRAM Mux				
PD11	A16	A16	-	-	Yes	Yes
PD12	A17	A17	-	-	Yes	Yes
PD13	A18	A18	-	-	Yes	Yes
PD14	D0	DA0	-	-	Yes	Yes
PD15	D1	DA1	-	-	Yes	Yes
PG2	A12	-	-	-	-	Yes
PG3	A13	-	-	-	-	Yes
PG4	A14	-	-	-	-	Yes
PG5	A15	-	-	-	-	Yes
PC6	D1	DA1	Yes	Yes	Yes	Yes
PC11	D2	DA2	Yes	Yes	Yes	Yes
PC12	D3	DA3	Yes	Yes	Yes	Yes
PD0	D2	DA2	-	Yes	Yes	Yes
PD1	D3	DA3	-	-	Yes	Yes
PD2	NWE	NWE	Yes	Yes	Yes	Yes
PD3	CLK	CLK	-	-	Yes	Yes
PD4	NOE	NOE	-	-	Yes	Yes
PD5	NWE	NWE	-	-	Yes	Yes
PD6	NWAIT	NWAIT	-	-	Yes	Yes
PD7	NE1	NE1	-	-	Yes	Yes
PG9	NE2	NE2	-	-	-	Yes
PG10	NE3	NE3	-	-	-	Yes
PG12	NE4	NE4	-	-	-	Yes
PG13	A24	A24	-	-	-	Yes
PG14	A25	A25	-	-	-	Yes
PB7	NL	NL	Yes	Yes	Yes	Yes
PE0	NBL0	NBL0	-	-	Yes	Yes
PE1	NBL1	NBL1	-	-	Yes	Yes



4.9 Alternate functions

Table 12. STM32F413xG/H alternate functions

Port	AF0	AF1	AF2	AF3	AF4	AF5	AF6	AF7	AF8	AF9	AF10	AF11	AF12	AF13	AF14	AF15
	SYS_AF	TIM1/2/ LPTIM1	TIM3/4/5	DFSDM2/ TIM8/9/10/11	I2C1/2/3/ I2CFMP1	SPI1/I2S1/ SPI2/I2S2/ SPI3/I2S3/ SPI4/I2S4	SPI2/I2S2/ SPI3/I2S3/ SPI4/I2S4/ SPI5/I2S5/ DFSDM1/2	SPI3/I2S3/ SAI1/ DFSDM2/ USART1/ USART2/ USART3	DFSDM1/ USART3/4/ 5/6/7/8/ CAN1	I2C2/I2C3/ I2CFMP1/ CAN1/2/ TIM12/13/14/ QUADSPI	SAI1/ DFSDM1/ DFSDM2/ QUADSPI/ FSMC /OTG1_FS	UART4/ UART5/ UART9/ UART10 /CAN3	FSMC /SDIO	-	RNG	SYS_AF
PA0	-	TIM2_CH1/ TIM2_ETR	TIM5_CH1	TIM8_ETR	-	-	-	USART2_CTS	UART4_TX	-	-	-	-	-	-	EVENT OUT
PA1	-	TIM2_CH2	TIM5_CH2	-	-	SPI4_MOSI/ S2S4_SD	-	USART2_RTS	UART4_RX	QUADSPI_BK1_IO3	-	-	-	-	-	EVENT OUT
PA2	-	TIM2_CH3	TIM5_CH3	TIM9_CH1	-	I2S2_CKIN	-	USART2_TX	-	-	-	-	FSMC_D4/ FSMC_DA4	-	-	EVENT OUT
PA3	-	TIM2_CH4	TIM5_CH4	TIM9_CH2	-	I2S2_MCK	-	USART2_RX	-	-	SAI1_SD_B	-	FSMC_D5/ FSMC_DA5	-	-	EVENT OUT
PA4	-	-	-	-	-	SPI1_NSS/ S1_WS	SPI3_NSS/ S2S3_WS	USART2_CK	DFSDM1_DATIN1	-	-	-	FSMC_D6/ FSMC_DA6	-	-	EVENT OUT
PA5	-	TIM2_CH1/ TIM2_ETR	-	TIM8_CH1N	-	SPI1_SCK/ S1_CK	-	-	DFSDM1_CKIN1	-	-	-	FSMC_D7/ FSMC_DA7	-	-	EVENT OUT
PA6	-	TIM1_BKIN	TIM3_CH1	TIM8_BKIN	-	SPI1_MISO	I2S2_MCK	DFSDM2_CKIN1	-	TIM13_CH1	QUADSPI_BK2_IO0	-	SDIO_CMD	-	-	EVENT OUT
PA7	-	TIM1_CH1N	TIM3_CH2	TIM8_CH1N	-	SPI1_MOSI/ S2S1_SD	-	DFSDM2_DATIN1	-	TIM14_CH1	QUADSPI_BK2_IO1	-	-	-	-	EVENT OUT
PA8	MCO_1	TIM1_CH1	-	-	I2C3_SCL	-	DFSDM1_CKOUT	USART1_CK	UART7_RX	-	USB_FS_SOF	CAN3_RX	SDIO_D1	-	-	EVENT OUT
PA9	-	TIM1_CH2	-	DFSDM2_CKIN3	I2C3_SMBA	SPI2_SCK/ S2_CK	-	USART1_TX	-	-	USB_FS_VBUS	-	SDIO_D2	-	-	EVENT OUT
PA10	-	TIM1_CH3	-	DFSDM2_DATIN3	-	SPI2_MOSI/ S2S2_SD	SPI5_MOSI/ I2S5_SD	USART1_RX	-	-	USB_FS_ID	-	-	-	-	EVENT OUT
PA11	-	TIM1_CH4	-	DFSDM2_CKIN5	-	SPI2_NSS/ S2_WS	SPI4_MISO	USART1_CTS	USART6_TX	CAN1_RX	USB_FS_DM	UART4_RX	-	-	-	EVENT OUT
PA12	-	TIM1_ETR	-	DFSDM2_DATIN5	-	SPI2_MISO	SPI5_MISO	USART1_RTS	USART6_RX	CAN1_TX	USB_FS_DP	UART4_TX	-	-	-	EVENT OUT
PA13	JTMS-SWDIO	-	-	-	-	-	-	-	-	-	-	-	-	-	-	EVENT OUT
PA14	JTCK-SWCLK	-	-	-	-	-	-	-	-	-	-	-	-	-	-	EVENT OUT
PA15	JTDI	TIM2_CH1/ TIM2_ETR	-	-	-	SPI1_NSS/ I2S1_WS	SPI3_NSS/ I2S3_WS	USART1_TX	UART7_TX	-	SAI1_MCLK_A	CAN3_TX	-	-	-	EVENT OUT

Port A



Table 12. STM32F413xG/H alternate functions (continued)

Port	AF0	AF1	AF2	AF3	AF4	AF5	AF6	AF7	AF8	AF9	AF10	AF11	AF12	AF13	AF14	AF15	
	SYS_AF	TIM1/2/ LPTIM1	TIM3/4/5	DFSDM2/ TIM8/9/10/11	I2C1/2/3/ I2CFMP1	SPI1/I2S1/ SPI2/I2S2/ SPI3/I2S3/ SPI4/I2S4/ SPI5/I2S5/ DFSDM1/2	SPI2/I2S2/ SPI3/I2S3/ SPI4/I2S4/ SPI5/I2S5/ DFSDM1/2	SPI3/I2S3/ SAI1/ DFSDM2/ USART1/ USART2/ USART3	DFSDM1/ USART3/4/ 5/6/7/8/ CAN1	I2C2/I2C3/ I2CFMP1/ CAN1/2/ TIM12/13/14/ QUADSPI	SAI1/ DFSDM1/ DFSDM2/ QUADSPI/ FSMC /OTG1_FS	UART4/ UART5/ UART9/ UART10 /CAN3	FSMC /SDIO	-	RNG	SYS_AF	
PB0	-	TIM1_CH2N	TIM3_CH3	TIM8_CH2N	-	-	SPI5_SCK/I2S5_CK	-	-	-	-	-	-	-	-	-	EVENT OUT
PB1	-	TIM1_CH3N	TIM3_CH4	TIM8_CH3N	-	-	SPI5_NSS/I2S5_WS	-	DFSDM1_DATIN0	QUADSPI_C LK	-	-	-	-	-	-	EVENT OUT
PB2	-	LPTIM1_OUT	-	-	-	-	DFSDM1_CKIN0	-	-	QUADSPI_C LK	-	-	-	-	-	-	EVENT OUT
PB3	JTDO-SWO	TIM2_CH2	-	-	I2CFMP1_SDA	SPI1_SCK/I2S1_CK	SPI3_SCK/I2S3_CK	USART1_RX	UART7_RX	I2C2_SDA	SAI1_SD_A	CAN3_RX	-	-	-	-	EVENT OUT
PB4	JTRST	-	TIM3_CH1	-	-	SPI1_MISO	SPI3_MISO	I2S3ext_SD	UART7_TX	I2C3_SDA	SAI1_SCK_A	CAN3_TX	SDIO_D0	-	-	-	EVENT OUT
PB5	-	LPTIM1_IN1	TIM3_CH2	-	I2C1_SMBA	SPI1_MOSI/I2S1_SD	SPI3_MOSI/I2S3_SD	-	-	CAN2_RX	SAI1_FS_A	UART5_RX	SDIO_D3	-	-	-	EVENT OUT
PB6	-	LPTIM1_ETR	TIM4_CH1	-	I2C1_SCL	-	DFSDM2_CKIN7	USART1_TX	-	CAN2_TX	QUADSPI_BK1_NCS	UART5_TX	SDIO_D0	-	-	-	EVENT OUT
PB7	-	LPTIM1_IN2	TIM4_CH2	-	I2C1_SDA	-	DFSDM2_DATIN7	USART1_RX	-	-	-	-	FSMC_NL	-	-	-	EVENT OUT
PB8	-	LPTIM1_OUT	TIM4_CH3	TIM10_CH1	I2C1_SCL	-	SPI5_MOSI/I2S5_SD	DFSDM2_CKIN1	CAN1_RX	I2C3_SDA	-	UART5_RX	SDIO_D4	-	-	-	EVENT OUT
PB9	-	-	TIM4_CH4	TIM11_CH1	I2C1_SDA	SPI2_NSS/I2S2_WS	DFSDM2_DATIN1	-	CAN1_TX	I2C2_SDA	-	UART5_TX	SDIO_D5	-	-	-	EVENT OUT
PB10	-	TIM2_CH3	-	-	I2C2_SCL	SPI2_SCK/I2S2_CK	I2S3_MCK	USART3_TX	-	I2CFMP1_SCL	DFSDM2_CKOUT	-	SDIO_D7	-	-	-	EVENT OUT
PB11	-	TIM2_CH4	-	-	I2C2_SDA	I2S2_CKIN	-	USART3_RX	-	-	-	-	-	-	-	-	EVENT OUT
PB12	-	TIM1_BKIN	-	-	I2C2_SMBA	SPI2_NSS/I2S2_WS	SPI4_NSS/I2S4_WS	SPI3_SCK/I2S3_CK	USART3_CK	CAN2_RX	DFSDM1_DATIN1	UART5_RX	FSMC_D13/FSMC_DA13	-	-	-	EVENT OUT
PB13	-	TIM1_CH1N	-	-	I2CFMP1_SMBA	SPI2_SCK/I2S2_CK	SPI4_SCK/I2S4_CK	-	USART3_CTS	CAN2_TX	DFSDM1_CKIN1	UART5_TX	-	-	-	-	EVENT OUT
PB14	-	TIM1_CH2N	-	TIM8_CH2N	I2CFMP1_SDA	SPI2_MISO	I2S2ext_SD	USART3_RTS	DFSDM1_DATIN2	TIM12_CH1	FSMC_D0/FSMC_DA0	-	SDIO_D6	-	-	-	EVENT OUT
PB15	RTC_REFIN	TIM1_CH3N	-	TIM8_CH3N	I2CFMP1_SCL	SPI2_MOSI/I2S2_SD	-	-	DFSDM1_CKIN2	TIM12_CH2	-	-	SDIO_CK	-	-	-	EVENT OUT

DocID029162 Rev 6

68/208

STM32F413xG/H

Pinouts and pin description



Table 12. STM32F413xG/H alternate functions (continued)

Port	AF0	AF1	AF2	AF3	AF4	AF5	AF6	AF7	AF8	AF9	AF10	AF11	AF12	AF13	AF14	AF15
	SYS_AF	TIM1/2/ LPTIM1	TIM3/4/5	DFSDM2/ TIM8/9/10/11	I2C1/2/3/ I2CFMP1	SPI1/I2S1/ SPI2/I2S2/ SPI3/I2S3/ SPI4/I2S4	SPI2/I2S2/ SPI3/I2S3/ SPI4/I2S4/ SPI5/I2S5/ DFSDM1/2	SPI3/I2S3/ SAI1/ DFSDM2/ USART1/ USART2/ USART3	DFSDM1/ USART3/4/ 5/6/7/8/ CAN1	I2C2/I2C3/ I2CFMP1/ CAN1/2/ TIM12/13/14/ QUADSPI	SAI1/ DFSDM1/ DFSDM2/ QUADSPI/ FSMC /OTG1_FS	UART4/ UART5/ UART9/ UART10 /CAN3	FSMC /SDIO	-	RNG	SYS_AF
PC0	-	LPTIM1_IN1	-	DFSDM2_CKIN4	-	-	-	SAI1_MCLK_B	-	-	-	-	-	-	-	EVENT OUT
PC1	-	LPTIM1_OUT	-	DFSDM2_DATIN4	-	-	-	SAI1_SD_B	-	-	-	-	-	-	-	EVENT OUT
PC2	-	LPTIM1_IN2	-	DFSDM2_DATIN7	-	SPI2_MISO	I2S2ext_SD	SAI1_SCK_B	DFSDM1_CKOUT	-	-	-	FSMC_NWE	-	-	EVENT OUT
PC3	-	LPTIM1_ETR	-	DFSDM2_CKIN7	-	SPI2_MOSI/I2S2_SD	-	SAI1_FS_B	-	-	-	-	FSMC_A0	-	-	EVENT OUT
PC4	-	-	-	DFSDM2_CKIN2	-	I2S1_MCK	-	-	-	-	QUADSPI_BK2_IO2	-	FSMC_NE4	-	-	EVENT OUT
PC5	-	-	-	DFSDM2_DATIN2	I2CFMP1_SMB	-	-	USART3_RX	-	-	QUADSPI_BK2_IO3	-	FSMC_NOE	-	-	EVENT OUT
PC6	-	-	TIM3_CH1	TIM8_CH1	I2CFMP1_SCL	I2S2_MCK	DFSDM1_CKIN3	DFSDM2_DATIN6	USART6_TX	-	FSMC_D1/ FSMC_DA1	-	SDIO_D6	-	-	EVENT OUT
PC7	-	-	TIM3_CH2	TIM8_CH2	I2CFMP1_SDA	SPI2_SCK/I2S2_CK	I2S3_MCK	DFSDM2_CKIN6	USART6_RX	-	DFSDM1_DATIN3	-	SDIO_D7	-	-	EVENT OUT
PC8	-	-	TIM3_CH3	TIM8_CH3	-	-	-	DFSDM2_CKIN3	USART6_CK	QUADSPI_BK1_IO2	-	-	SDIO_D0	-	-	EVENT OUT
PC9	MCO_2	-	TIM3_CH4	TIM8_CH4	I2C3_SDA	I2S2_CKIN	-	DFSDM2_DATIN3	-	QUADSPI_BK1_IO0	-	-	SDIO_D1	-	-	EVENT OUT
PC10	-	-	-	DFSDM2_CKIN5	-	-	SPI3_SCK/I2S3_CK	USART3_TX	-	QUADSPI_BK1_IO1	-	-	SDIO_D2	-	-	EVENT OUT
PC11	-	-	-	DFSDM2_DATIN5	-	I2S3ext_SD	SPI3_MISO	USART3_RX	UART4_RX	QUADSPI_BK2_NCS	FSMC_D2/ FSMC_DA2	-	SDIO_D3	-	-	EVENT OUT
PC12	-	-	-	-	-	-	SPI3_MOSI/I2S3_SD	USART3_CK	UART5_TX	-	FSMC_D3/ FSMC_DA3	-	SDIO_CK	-	-	EVENT OUT
PC13	-	-	-	-	-	-	-	-	-	-	-	-	-	-	-	EVENT OUT
PC14	-	-	-	-	-	-	-	-	-	-	-	-	-	-	-	EVENT OUT
PC15	-	-	-	-	-	-	-	-	-	-	-	-	-	-	-	EVENT OUT



Table 12. STM32F413xG/H alternate functions (continued)

Port	AF0	AF1	AF2	AF3	AF4	AF5	AF6	AF7	AF8	AF9	AF10	AF11	AF12	AF13	AF14	AF15	
	SYS_AF_	TIM1/2/ LPTIM1	TIM3/4/5	DFSDM2/ TIM8/9/10/11	I2C1/2/3/ I2CFMP1	SPI1/I2S1/ SPI2/I2S2/ SPI3/I2S3/ SPI4/I2S4/ SPI5/I2S5/ SPI4/I2S4	SPI2/I2S2/ SPI3/I2S3/ SPI4/I2S4/ SPI5/I2S5/ DFSDM1/2	SPI3/I2S3/ SAI1/ DFSDM2/ USART1/ USART2/ USART3	DFSDM1/ USART3/4/ 5/6/7/8/ CAN1	I2C2/I2C3/ I2CFMP1/ CAN1/2/ TIM12/13/14/ QUADSPI	SAI1/ DFSDM1/ DFSDM2/ QUADSPI/ FSMC /OTG1_FS	UART4/ UART5/ UART9/ UART10 /CAN3	FSMC /SDIO	-	RNG	SYS_AF_	
Port D	PD0	-	-	-	DFSDM2_ CKIN6	-	-	-	-	CAN1_RX	-	UART4_ RX	FSMC_D2/ FSMC_DA2	-	-	EVENT OUT	
	PD1	-	-	-	DFSDM2_ DATIN6	-	-	-	-	CAN1_TX	-	UART4_ TX	FSMC_D3/ FSMC_DA3	-	-	EVENT OUT	
	PD2	-	-	TIM3_ ETR	DFSDM2_ CKOUT	-	-	-	UART5_ RX	-	FSMC_ NWE	-	SDIO_CMD	-	-	EVENT OUT	
	PD3	TRACE D1	-	-	-	-	SPI2_SCK/ I2S2_CK	DFSDM1_ DATIN0	USART2_ CTS	-	QUADSPI_ CLK	-	-	FSMC_CLK	-	-	EVENT OUT
	PD4	-	-	-	-	-	-	DFSDM1_ CKIN0	USART2_ RTS	-	-	-	-	FSMC_ NOE	-	-	EVENT OUT
	PD5	-	-	-	DFSDM2_ CKOUT	-	-	-	USART2_ TX	-	-	-	-	FSMC_ NWE	-	-	EVENT OUT
	PD6	-	-	-	-	-	SPI3_MOSI/ I2S3_SD	DFSDM1_ DATIN1	USART2_ RX	-	-	-	-	FSMC_ NWAIT	-	-	EVENT OUT
	PD7	-	-	-	-	-	-	DFSDM1_ CKIN1	USART2_ CK	-	-	-	-	FSMC_ NE1	-	-	EVENT OUT
	PD8	-	-	-	-	-	-	-	USART3_ TX	-	-	-	-	FSMC_D13/ SMC_DA13	-	-	EVENT OUT
	PD9	-	-	-	-	-	-	-	USART3_ RX	-	-	-	-	FSMC_D14/ SMC_DA14	-	-	EVENT OUT
	PD10	-	-	-	-	-	-	-	USART3_ CK	UART4_ TX	-	-	-	FSMC_D15/ SMC_DA15	-	-	EVENT OUT
	PD11	-	-	-	DFSDM2_ DATIN2	I2CFMP1_ SMBA	-	-	USART3_ CTS	-	QUADSPI_ BK1_IO0	-	-	FSMC_A16	-	-	EVENT OUT
	PD12	-	-	TIM4_ CH1	DFSDM2_ CKIN2	I2CFMP1_ SCL	-	-	USART3_ RTS	-	QUADSPI_ BK1_IO1	-	-	FSMC_A17	-	-	EVENT OUT
	PD13	-	-	TIM4_ CH2	-	I2CFMP1_ SDA	-	-	-	-	QUADSPI_ BK1_IO3	-	-	FSMC_A18	-	-	EVENT OUT
	PD14	-	-	TIM4_ CH3	-	I2CFMP1_ SCL	-	-	-	-	-	DFSDM2_ CKIN0	UART9_ RX	FSMC_D0/ FSMC_DA0	-	-	EVENT OUT
PD15	-	-	TIM4_ CH4	-	I2CFMP1_ SDA	-	-	-	-	-	DFSDM2_ DATIN0	UART9_ TX	FSMC_D1/ FSMC_DA1	-	-	EVENT OUT	



Table 12. STM32F413xG/H alternate functions (continued)

Port	AF0	AF1	AF2	AF3	AF4	AF5	AF6	AF7	AF8	AF9	AF10	AF11	AF12	AF13	AF14	AF15	
	SYS_AF	TIM1/2/ LPTIM1	TIM3/4/5	DFSDM2/ TIM8/9/10/11	I2C1/2/3/ I2CFMP1	SPI1/I2S1/ SPI2/I2S2/ SPI3/I2S3/ SPI4/I2S4	SPI2/I2S2/ SPI3/I2S3/ SPI4/I2S4/ SPI5/I2S5/ DFSDM1/2	SPI3/I2S3/ SAI1/ DFSDM2/ USART1/ USART2/ USART3	DFSDM1/ USART3/4/ 5/6/7/8/ CAN1	I2C2/I2C3/ I2CFMP1/ CAN1/2/ TIM12/13/14/ QUADSPI	SAI1/ DFSDM1/ DFSDM2/ QUADSPI/ FSMC /OTG1_FS	UART4/ UART5/ UART9/ UART10 /CAN3	FSMC /SDIO	-	RNG	SYS_AF	
Port E	PE0	-	-	TIM4_ETR	DFSDM2_CKIN4	-	-	-	UART8_Rx	-	-	-	FSMC_NBL0	-	-	EVENT OUT	
	PE1	-	-	-	DFSDM2_DATIN4	-	-	-	UART8_Tx	-	-	-	FSMC_NBL1	-	-	EVENT OUT	
	PE2	TRACE_CLK	-	-	-	-	SPI4_SCK/I2S4_CK	SPI5_SCK/I2S5_CK	SAI1_MCLK_A	-	QUADSPI_BK1_IO2	-	UART10_RX	FSMC_A23	-	-	EVENT OUT
	PE3	TRACE_D0	-	-	-	-	-	SAI1_SD_B	-	-	-	-	UART10_TX	FSMC_A19	-	-	EVENT OUT
	PE4	TRACE_D1	-	-	-	-	SPI4_NSS/I2S4_WS	SPI5_NSS/I2S5_WS	SAI1_SD_A	DFSDM1_DATIN3	-	-	-	FSMC_A20	-	-	EVENT OUT
	PE5	TRACE_D2	-	-	TIM9_CH1	-	SPI4_MISO	SPI5_MISO	SAI1_SCK_A	DFSDM1_CKIN3	-	-	-	FSMC_A21	-	-	EVENT OUT
	PE6	TRACE_D3	-	-	TIM9_CH2	-	SPI4_MOSI/I2S4_SD	SPI5_MOSI/I2S5_SD	SAI1_FS_A	-	-	-	-	FSMC_A22	-	-	EVENT OUT
	PE7	-	TIM1_ETR	-	-	-	-	DFSDM1_DATIN2	-	UART7_Rx	-	QUADSPI_BK2_IO0	-	FSMC_D4/ FSMC_DA4	-	-	EVENT OUT
	PE8	-	TIM1_CH1N	-	-	-	-	DFSDM1_CKIN2	-	UART7_Tx	-	QUADSPI_BK2_IO1	-	FSMC_D5/ FSMC_DA5	-	-	EVENT OUT
	PE9	-	TIM1_CH1	-	-	-	-	DFSDM1_CKOUT	-	-	-	QUADSPI_BK2_IO2	-	FSMC_D6/ FSMC_DA6	-	-	EVENT OUT
	PE10	-	TIM1_CH2N	-	DFSDM2_DATIN0	-	-	-	-	-	-	QUADSPI_BK2_IO3	-	FSMC_D7/ FSMC_DA7	-	-	EVENT OUT
	PE11	-	TIM1_CH2	-	DFSDM2_CKIN0	-	SPI4_NSS/I2S4_WS	SPI5_NSS/I2S5_WS	-	-	-	-	-	FSMC_D8/ FSMC_DA8	-	-	EVENT OUT
	PE12	-	TIM1_CH3N	-	DFSDM2_DATIN7	-	SPI4_SCK/I2S4_CK	SPI5_SCK/I2S5_CK	-	-	-	-	-	FSMC_D9/ FSMC_DA9	-	-	EVENT OUT
	PE13	-	TIM1_CH3	-	DFSDM2_CKIN7	-	SPI4_MISO	SPI5_MISO	-	-	-	-	-	FSMC_D10/ FSMC_DA10	-	-	EVENT OUT
	PE14	-	TIM1_CH4	-	-	-	SPI4_MOSI/I2S4_SD	SPI5_MOSI/I2S5_SD	-	-	-	DFSDM2_DATIN1	-	FSMC_D11/ FSMC_DA11	-	-	EVENT OUT
	PE15	-	TIM1_BKIN	-	-	-	-	-	-	-	-	DFSDM2_CKIN1	-	FSMC_D12/ FSMC_DA12	-	-	EVENT OUT



Table 12. STM32F413xG/H alternate functions (continued)

Port	AF0	AF1	AF2	AF3	AF4	AF5	AF6	AF7	AF8	AF9	AF10	AF11	AF12	AF13	AF14	AF15	
	SYS_AF	TIM1/2/ LPTIM1	TIM3/4/5	DFSDM2/ TIM8/9/10/11	I2C1/2/3/ I2CFMP1	SPI1/I2S1/ SPI2/I2S2/ SPI3/I2S3/ SPI4/I2S4	SPI2/I2S2/ SPI3/I2S3/ SPI4/I2S4/ SPI5/I2S5/ DFSDM1/2	SPI3/I2S3/ SAI1/ DFSDM2/ USART1/ USART2/ USART3	DFSDM1/ USART3/4/ 5/6/7/8/ CAN1	I2C2/I2C3/ I2CFMP1/ CAN1/2/ TIM12/13/14/ QUADSPI	SAI1/ DFSDM1/ DFSDM2/ QUADSPI/ FSMC /OTG1_FS	UART4/ UART5/ UART9/ UART10 /CAN3	FSMC /SDIO	-	RNG	SYS_AF	
Port F	PF0	-	-	-	-	I2C2_SDA	-	-	-	-	-	-	FSMC_A0	-	-	EVENT OUT	
	PF1	-	-	-	-	I2C2_SCL	-	-	-	-	-	-	FSMC_A1	-	-	EVENT OUT	
	PF2	-	-	-	-	I2C2_SMBA	-	-	-	-	-	-	FSMC_A2	-	-	EVENT OUT	
	PF3	-	-	TIM5_CH1	-	-	-	-	-	-	-	-	FSMC_A3	-	-	EVENT OUT	
	PF4	-	-	TIM5_CH2	-	-	-	-	-	-	-	-	FSMC_A4	-	-	EVENT OUT	
	PF5	-	-	TIM5_CH3	-	-	-	-	-	-	-	-	FSMC_A5	-	-	EVENT OUT	
	PF6	TRACE D0	-	-	TIM10_CH1	-	-	-	SAI1_SD_B	UART7_Rx	QUADSPI_BK1_IO3	-	-	-	-	-	EVENT OUT
	PF7	TRACE D1	-	-	TIM11_CH1	-	-	-	SAI1_MCLK_B	UART7_Tx	QUADSPI_BK1_IO2	-	-	-	-	-	EVENT OUT
	PF8	-	-	-	-	-	-	-	SAI1_SCK_B	UART8_RX	TIM13_CH1	QUADSPI_BK1_IO0	-	-	-	-	EVENT OUT
	PF9	-	-	-	-	-	-	-	SAI1_FS_B	UART8_TX	TIM14_CH1	QUADSPI_BK1_IO1	-	-	-	-	EVENT OUT
	PF10	-	TIM1_ETR	TIM5_CH4	-	-	-	-	-	-	-	-	-	-	-	-	EVENT OUT
	PF11	-	-	-	TIM8_ETR	-	-	-	-	-	-	-	-	-	-	-	EVENT OUT
	PF12	-	-	-	TIM8_BKIN	-	-	-	-	-	-	-	-	FSMC_A6	-	-	EVENT OUT
	PF13	-	-	-	-	I2CFMP1_SMBA	-	-	-	-	-	-	-	FSMC_A7	-	-	EVENT OUT
	PF14	-	-	-	-	I2CFMP1_SCL	-	-	-	-	-	-	-	FSMC_A8	-	-	EVENT OUT
PF15	-	-	-	-	I2CFMP1_SDA	-	-	-	-	-	-	-	FSMC_A9	-	-	EVENT OUT	



Table 12. STM32F413xG/H alternate functions (continued)

Port	AF0	AF1	AF2	AF3	AF4	AF5	AF6	AF7	AF8	AF9	AF10	AF11	AF12	AF13	AF14	AF15
	SYS_AF_	TIM1/2/ LPTIM1	TIM3/4/5	DFSDM2/ TIM8/9/10/11	I2C1/2/3/ I2CFMP1	SPI1/I2S1/ SPI2/I2S2/ SPI3/I2S3/ SPI4/I2S4	SPI2/I2S2/ SPI3/I2S3/ SPI4/I2S4/ SPI5/I2S5/ DFSDM1/2	SPI3/I2S3/ SAI1/ DFSDM2/ USART1/ USART2/ USART3	DFSDM1/ USART3/4/ 5/6/7/8/ CAN1	I2C2/I2C3/ I2CFMP1/ CAN1/2/ TIM12/13/14/ QUADSPI	SAI1/ DFSDM1/ DFSDM2/ QUADSPI/ FSMC /OTG1_FS	UART4/ UART5/ UART9/ UART10 /CAN3	FSMC /SDIO	-	RNG	SYS_AF_
Port G	PG0	-	-	-	-	-	-	-	-	CAN1_RX	-	UART9_RX	FSMC_A10	-	-	EVENT OUT
	PG1	-	-	-	-	-	-	-	-	CAN1_TX	-	UART9_TX	FSMC_A11	-	-	EVENT OUT
	PG2	-	-	-	-	-	-	-	-	-	-	-	FSMC_A12	-	-	EVENT OUT
	PG3	-	-	-	-	-	-	-	-	-	-	-	FSMC_A13	-	-	EVENT OUT
	PG4	-	-	-	-	-	-	-	-	-	-	-	FSMC_A14	-	-	EVENT OUT
	PG5	-	-	-	-	-	-	-	-	-	-	-	FSMC_A15	-	-	EVENT OUT
	PG6	-	-	-	-	-	-	-	-	-	-	QUADSPI_B K1_NCS	-	-	-	EVENT OUT
	PG7	-	-	-	-	-	-	-	USART6_	-	-	-	-	-	-	EVENT OUT
	PG8	-	-	-	-	-	-	-	RTS	-	-	-	-	-	-	EVENT OUT
	PG9	-	-	-	-	-	-	-	RX	QUADSPI_	-	-	FSMC_NE2	-	-	EVENT OUT
	PG10	-	-	-	-	-	-	-	-	-	-	-	FSMC_NE3	-	-	EVENT OUT
	PG11	-	-	-	-	-	-	-	-	CAN2_RX	-	UART10_RX	-	-	-	EVENT OUT
	PG12	-	-	-	-	-	-	-	USART6_	CAN2_TX	-	UART10_TX	FSMC_NE4	-	-	EVENT OUT
	PG13	TRACE D2	-	-	-	-	-	-	CTS	-	-	-	FSMC_A24	-	-	EVENT OUT
	PG14	TRACE D3	-	-	-	-	-	-	USART6_	QUADSPI_	-	-	FSMC_A25	-	-	EVENT OUT
PG15	-	-	-	-	-	-	-	USART6_	-	-	-	-	-	-	EVENT OUT	
Port H	PH0	-	-	-	-	-	-	-	-	-	-	-	-	-	-	EVENT OUT
	PH1	-	-	-	-	-	-	-	-	-	-	-	-	-	-	EVENT OUT

5 Memory mapping

The memory map is shown in [Figure 18](#).

Figure 18. Memory map

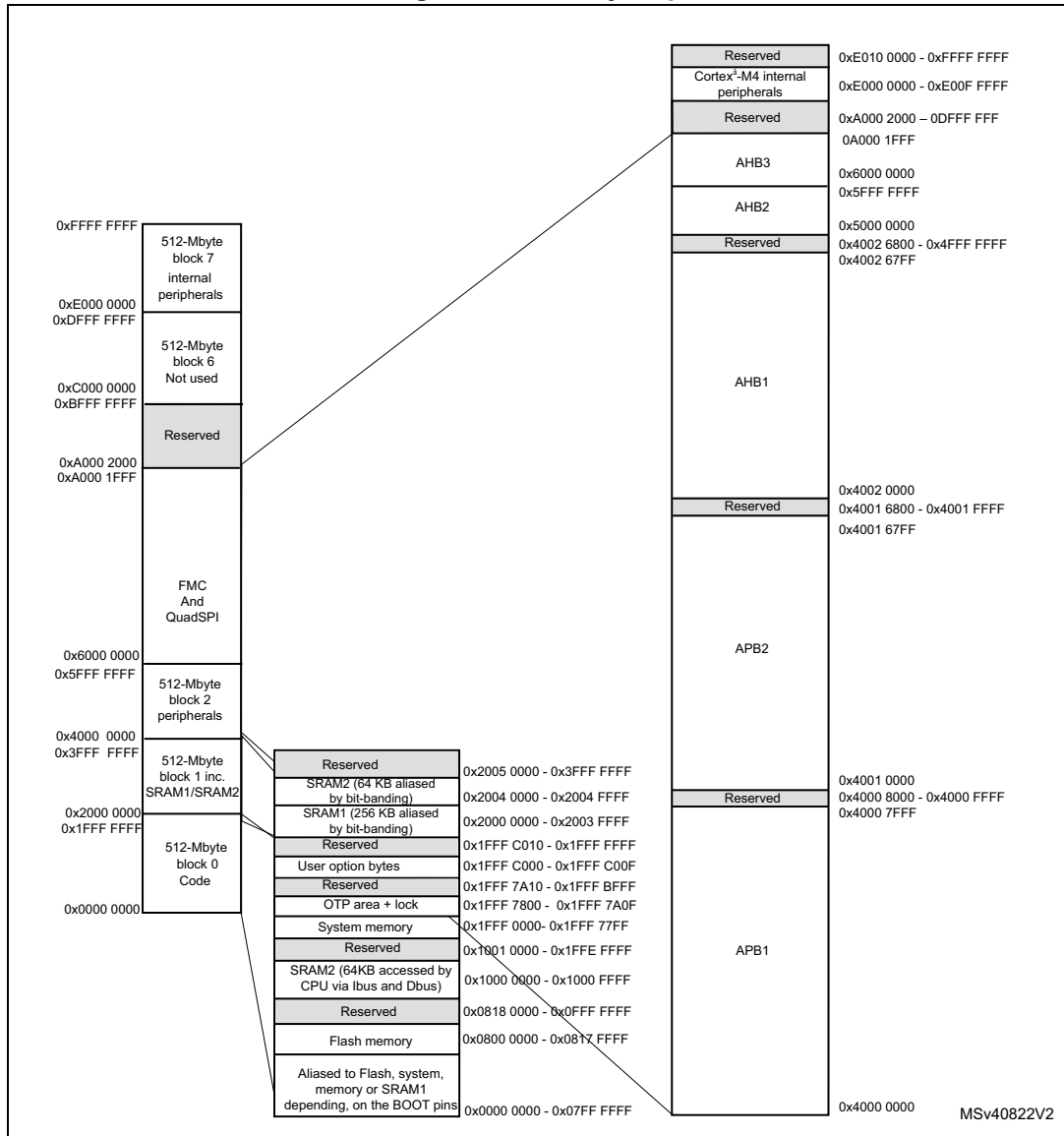

Table 13. STM32F413xG/H register boundary addresses

Bus	Boundary address	Peripheral
	0xE010 0000 - 0xFFFF FFFF	Reserved
Cortex [®] -M4	0xE000 0000 - 0xE00F FFFF	Cortex-M4 internal peripherals
AHB3	0xA000 2000 - 0xDFFF FFFF	Reserved
	0xA000 1000 - 0xA000 1FFF	QuadSPI control register
	0xA000 0000 - 0xA000 0FFF	FSMC control register
	0x9000 0000 - 0x9FFF FFFF	QUADSPI
	0x7000 0000 - 0x08FFF FFFF	Reserved
	0x6000 0000 - 0x6FFF FFFF	FSMC
AHB2	0x5006 0C00 - 0x5FFF FFFF	Reserved
	0x5006 0800 - 0x5006 0BFF	RNG
	0x5004 0000 - 0x5006 07FF	Reserved
	0x5000 0000 - 0x5003 FFFF	USB OTG FS
AHB1	0x4002 6800 - 0x4FFF FFFF	Reserved
	0x4002 6400 - 0x4002 67FF	DMA2
	0x4002 6000 - 0x4002 63FF	DMA1
	0x4002 4000 - 0x4002 5FFF	Reserved
	0x4002 3C00 - 0x4002 3FFF	Flash interface register
	0x4002 3800 - 0x4002 3BFF	RCC
	0x4002 3400 - 0x4002 37FF	Reserved
	0x4002 3000 - 0x4002 33FF	CRC
	0x4002 2000 - 0x4002 2FFF	Reserved
	0x4002 1C00 - 0x4002 1FFF	GPIOH
	0x4002 1800 - 0x4002 1BFF	GPIOG
	0x4002 1400 - 0x4002 17FF	GPIOF
	0x4002 1000 - 0x4002 13FF	GPIOE
	0x4002 0C00 - 0x4002 0FFF	GIOD
	0x4002 0800 - 0x4002 0BFF	GPIOC
	0x4002 0400 - 0x4002 07FF	GPIOB
	0x4002 0000 - 0x4002 03FF	GPIOA

Table 13. STM32F413xG/H register boundary addresses (continued)

Bus	Boundary address	Peripheral
APB2	0x4001 6800 - 0x4001 FFFF	Reserved
	0x4001 6400 - 0x4001 67FF	DFSDM2
	0x4001 6000 - 0x4001 63FF	DFSDM1
	0x4001 5C00 - 0x4001 5FFF	Reserved
	0x4001 5800 - 0x4001 5BFF	SAI1
	0x4001 5400 - 0x4001 57FF	Reserved
	0x4001 5000 - 0x4001 53FF	SPI5/I2S5
	0x4001 4C00 - 0x4001 4FFF	Reserved
	0x4001 4800 - 0x4001 4BFF	TIM11
	0x4001 4400 - 0x4001 47FF	TIM10
	0x4001 4000 - 0x4001 43FF	TIM9
	0x4001 3C00 - 0x4001 3FFF	EXTI
	0x4001 3800 - 0x4001 3BFF	SYSCFG
	0x4001 3400 - 0x4001 37FF	SPI4/I2S4
	0x4001 3000 - 0x4001 33FF	SPI1/I2S1
	0x4001 2C00 - 0x4001 2FFF	SDIO
	0x4001 2400 - 0x4001 2BFF	Reserved
	0x4001 2000 - 0x4001 23FF	ADC1/2/3
	0x4001 1C00 - 0x4001 1FFF	UART10
	0x4001 1800 - 0x4001 1BFF	UART9
	0x4001 1400 - 0x4001 17FF	USART6
	0x4001 1000 - 0x4001 13FF	USART1
	0x4001 0800 - 0x4001 0FFF	Reserved
	0x4001 0400 - 0x4001 07FF	TIM8
	0x4001 0000 - 0x4001 03FF	TIM1

Table 13. STM32F413xG/H register boundary addresses (continued)

Bus	Boundary address	Peripheral
APB1	0x4000 8000 - 0x4000 FFFF	Reserved
	0x4000 7C00 - 0x4000 7FFF	UART8
	0x4000 7800 - 0x4000 7BFF	UART7
	0x4000 7400 - 0x4000 77FF	DAC1
	0x4000 7000 - 0x4000 73FF	PWR
	0x4000 6C00- 0x4000 6FFF	CAN3
	0x4000 6800- 0x4000 6BFF	CAN2
	0x4000 6400- 0x4000 67FF	CAN1
	0x4000 6000- 0x4000 63FF	I2CFMP1
	0x4000 5C00 - 0x4000 5FFF	I2C3
	0x4000 5800 - 0x4000 5BFF	I2C2
	0x4000 5400 - 0x4000 57FF	I2C1
	0x4000 5000 - 0x4000 53FF	UART5
	0x4000 4C00 - 0x4000 4FFF	UART4
	0x4000 4800 - 0x4000 4BFF	USART3
	0x4000 4400 - 0x4000 47FF	USART2
	0x4000 4000 - 0x4000 43FF	I2S3ext
	0x4000 3C00 - 0x4000 3FFF	SPI3 / I2S3
	0x4000 3800 - 0x4000 3BFF	SPI2 / I2S2
	0x4000 3400 - 0x4000 37FF	I2S2ext
	0x4000 3000 - 0x4000 33FF	IWDG
	0x4000 2C00 - 0x4000 2FFF	WWDG
	0x4000 2800 - 0x4000 2BFF	RTC & BKP Registers
	0x4000 2400 - 0x4000 27FF	LPTIM1
	0x4000 2000 - 0x4000 23FF	TIM14
	0x4000 1C00 - 0x4000 1FFF	TIM13
	0x4000 1800 - 0x4000 1BFF	TIM12
	0x4000 1400 - 0x4000 17FF	TIM7
	0x4000 1000 - 0x4000 13FF	TIM6
	0x4000 0C00 - 0x4000 0FFF	TIM5
0x4000 0800 - 0x4000 0BFF	TIM4	
0x4000 0400 - 0x4000 07FF	TIM3	
0x4000 0000 - 0x4000 03FF	TIM2	

6 Electrical characteristics

6.1 Parameter conditions

Unless otherwise specified, all voltages are referenced to V_{SS} .

6.1.1 Minimum and maximum values

Unless otherwise specified the minimum and maximum values are guaranteed in the worst conditions of ambient temperature, supply voltage and frequencies by tests in production on 100% of the devices with an ambient temperature at $T_A = 25\text{ }^\circ\text{C}$ and $T_A = T_{Amax}$ (given by the selected temperature range).

Data based on characterization results, design simulation and/or technology characteristics are indicated in the table footnotes and are not tested in production. Based on characterization, the minimum and maximum values refer to sample tests and represent the mean value plus or minus three times the standard deviation (mean $\pm 3\sigma$).

6.1.2 Typical values

Unless otherwise specified, typical data are based on $T_A = 25\text{ }^\circ\text{C}$, $V_{DD} = 3.3\text{ V}$ (for the $1.7\text{ V} \leq V_{DD} \leq 3.6\text{ V}$ voltage range). They are given only as design guidelines and are not tested.

Typical ADC accuracy values are determined by characterization of a batch of samples from a standard diffusion lot over the full temperature range, where 95% of the devices have an error less than or equal to the value indicated (mean $\pm 2\sigma$).

6.1.3 Typical curves

Unless otherwise specified, all typical curves are given only as design guidelines and are not tested.

6.1.4 Loading capacitor

The loading conditions used for pin parameter measurement are shown in [Figure 19](#).

6.1.5 Pin input voltage

The input voltage measurement on a pin of the device is described in [Figure 20](#).

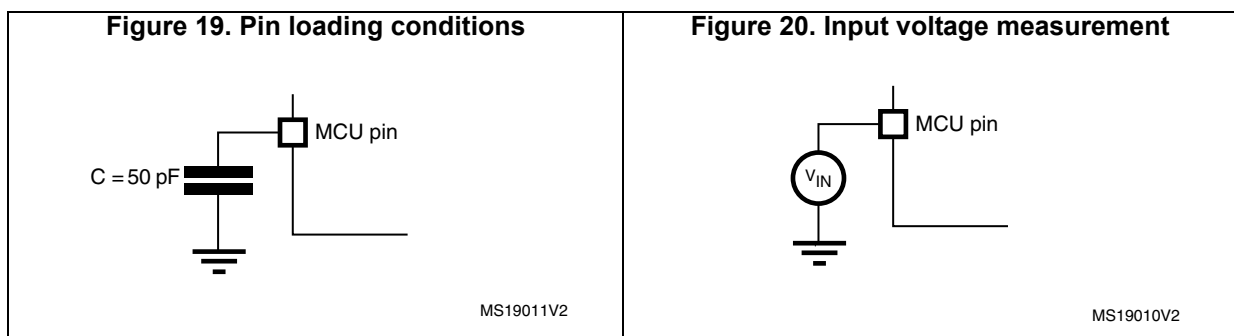

6.1.6 Power supply scheme

Figure 21. Power supply scheme

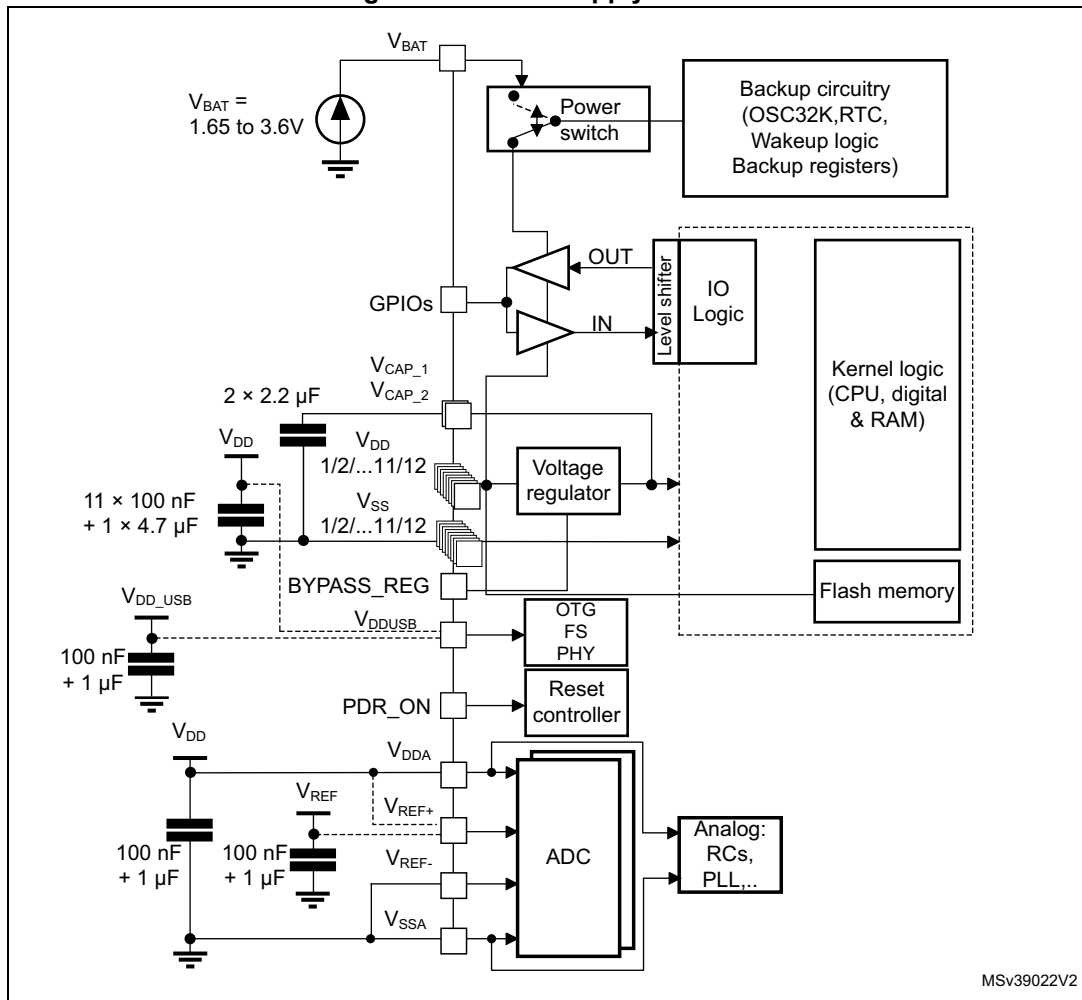

1. To connect PDR_ON pin, refer to Section: Power supply supervisor.
2. The 4.7 µF ceramic capacitor must be connected to one of the V_{DD} pin.
3. VCAP_2 pad is only available on 100-pin and 144-pin packages.
4. V_{DDA}=V_{DD} and V_{SSA}=V_{SS}.
5. V_{DDUSB} is a dedicated independent USB power supply for the on-chip full-speed OTG PHY module and associated DP/DM GPIOs. V_{DDUSB} value does not depend on the V_{DD} and V_{DDA} values, but it must be the last supply to be provided and the first to disappear.

Caution: Each power supply pair (for example V_{DD}/V_{SS}, V_{DDA}/V_{SSA}) must be decoupled with filtering ceramic capacitors as shown above. These capacitors must be placed as close as possible to, or below, the appropriate pins on the underside of the PCB to ensure good operation of the device. It is not recommended to remove filtering capacitors to reduce PCB size or cost. This might cause incorrect operation of the device.

6.1.7 Current consumption measurement

Figure 22. Current consumption measurement scheme

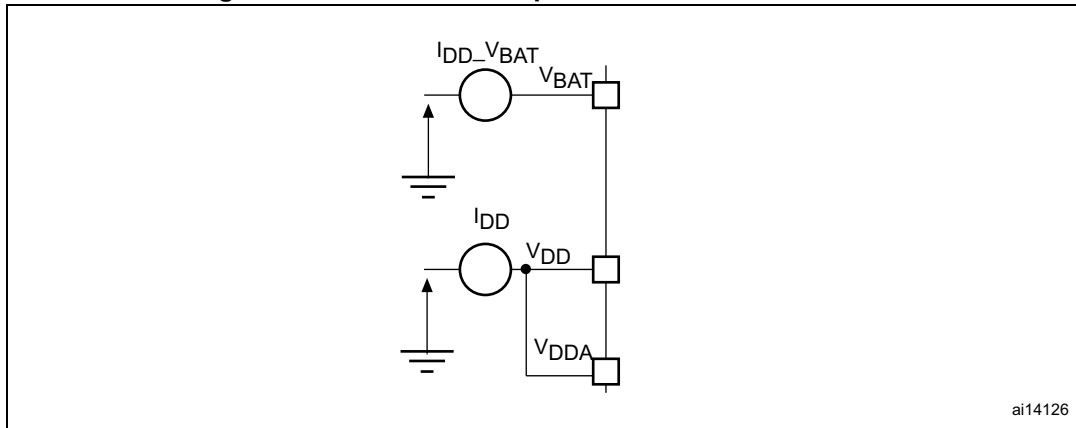

6.2 Absolute maximum ratings

Stresses above the absolute maximum ratings listed in [Table 14: Voltage characteristics](#), [Table 15: Current characteristics](#), and [Table 16: Thermal characteristics](#) may cause permanent damage to the device. These are stress ratings only and functional operation of the device at these conditions is not implied. Exposure to maximum rating conditions for extended periods may affect device reliability.

Table 14. Voltage characteristics

Symbol	Ratings	Min	Max	Unit
$V_{DD}-V_{SS}$	External main supply voltage (including V_{DDA} , V_{DD} , V_{DDUSB} and V_{BAT}) ⁽¹⁾	-0.3	4.0	V
V_{IN}	Input voltage on FT and TC pins ⁽²⁾	$V_{SS}-0.3$	$V_{DD}+4.0$	
	Input voltage on TTa pins	$V_{SS}-0.3$	4.0	
	Input voltage on any other pin	$V_{SS}-0.3$	4.0	
	Input voltage for BOOT0	V_{SS}	9.0	
$ \Delta V_{DDx} $	Variations between different V_{DD} power pins	-	50	mV
$ V_{SSx}-V_{SS} $	Variations between all the different ground pins including V_{REF-}	-	50	
$V_{ESD(HBM)}$	Electrostatic discharge voltage (human body model)	see Section 6.3.14: Absolute maximum ratings (electrical sensitivity)		

1. All main power (V_{DD} , V_{DDA} , V_{DDUSB}) and ground (V_{SS} , V_{SSA}) pins must always be connected to the external power supply, in the permitted range.
2. V_{IN} maximum value must always be respected. Refer to [Table 15](#) for the values of the maximum allowed injected current.

Table 15. Current characteristics

Symbol	Ratings	Max.	Unit
ΣI_{VDD}	Total current into sum of all V_{DD_x} power lines (source) ⁽¹⁾	180	mA
ΣI_{VSS}	Total current out of sum of all V_{SS_x} ground lines (sink) ⁽¹⁾	-180	
ΣI_{VDDUSB}	Total current into V_{DDUSB} power lines (source)	25	
I_{VDD}	Maximum current into each V_{DD_x} power line (source) ⁽¹⁾	100	
I_{VSS}	Maximum current out of each V_{SS_x} ground line (sink) ⁽¹⁾	-100	
I_{IO}	Output current sunk by any I/O and control pin	25	
	Output current sourced by any I/O and control pin	-25	
ΣI_{IO}	Total output current sunk by sum of all I/O and control pins ⁽²⁾	120	
	Total output current sunk by sum of all USB I/Os	25	
	Total output current sourced by sum of all I/Os and control pins ⁽²⁾	-120	
$I_{INJ(PIN)}$ ⁽³⁾	Injected current on FT and TC pins ⁽⁴⁾	- 5/ + 0	
	Injected current on NRST and B pins ⁽⁴⁾		
	Injected current on TTA pins ⁽⁵⁾	± 5	
$\Sigma I_{INJ(PIN)}$	Total injected current (sum of all I/O and control pins) ⁽⁶⁾	± 25	

1. All main power (V_{DD} , V_{DDA} , V_{DDUSB}) and ground (V_{SS} , V_{SSA}) pins must always be connected to the external power supply, in the permitted range.
2. This current consumption must be correctly distributed over all I/Os and control pins.
3. Negative injection disturbs the analog performance of the device. See note in [Section 6.3.20: 12-bit ADC characteristics](#).
4. Positive injection is not possible on these I/Os and does not occur for input voltages lower than the specified maximum value.
5. A positive injection is induced by $V_{IN} > V_{DDA}$ in the same time a negative injection is induced by $V_{IN} < V_{SS}$. $I_{INJ(PIN)}$ must never be exceeded. Refer to [Table 14](#) for the values of the maximum allowed input voltage.
6. When several inputs are submitted to a current injection, the maximum $\Sigma I_{INJ(PIN)}$ is the absolute sum of the positive and negative injected currents (instantaneous values).

Table 16. Thermal characteristics

Symbol	Ratings	Value	Unit
T_{STG}	Storage temperature range	-65 to +150	°C
T_J	Maximum junction temperature	125	
T_{LEAD}	Maximum lead temperature during soldering (WLCSP81, LQFP64/100/144, UFQFPN48, UFBGA100/144)	see note ⁽¹⁾	

1. Compliant with JEDEC Std J-STD-020D (for small body, Sn-Pb or Pb assembly), the ST ECOPACK[®] 7191395 specification, and the European directive on Restrictions on Hazardous Substances (ROHS directive 2011/65/EU, July 2011).

6.3 Operating conditions

6.3.1 General operating conditions

Table 17. General operating conditions

Symbol	Parameter	Conditions	Min	Typ	Max	Unit
f _{HCLK}	Internal AHB clock frequency	Power Scale3: Regulator ON, VOS[1:0] bits in PWR_CR register = 0x01	0	-	64	MHz
		Power Scale2: Regulator ON, VOS[1:0] bits in PWR_CR register = 0x10	0	-	84	
		Power Scale1: Regulator ON, VOS[1:0] bits in PWR_CR register = 0x11	0	-	100	
f _{PCLK1}	Internal APB1 clock frequency	-	0	-	50	MHz
f _{PCLK2}	Internal APB2 clock frequency	-	0	-	100	MHz
V _{DD}	Standard operating voltage	-	1.7 ⁽¹⁾	-	3.6	V
V _{DDA} ⁽²⁾⁽³⁾	Analog operating voltage (ADC limited to 1.2 M samples)	Must be the same potential as V _{DD} ⁽⁴⁾	1.7 ⁽¹⁾	-	2.4	V
	Analog operating voltage (ADC limited to 2.4 M samples)		2.4	-	3.6	
V _{DDUSB}	USB supply voltage (supply voltage for PA11 and PA12 pins)	USB not used	1.7	3.3	3.6	V
		USB used ⁽⁵⁾	3.0	-	3.6	
V _{BAT}	Backup operating voltage	-	1.65	-	3.6	V
V ₁₂	Regulator ON: 1.2 V internal voltage on VCAP_1/VCAP_2 pins	VOS[1:0] bits in PWR_CR register = 0x01 Max frequency 64 MHz	1.08 ⁽⁶⁾	1.14	1.20 ⁽⁶⁾	V
		VOS[1:0] bits in PWR_CR register = 0x10 Max frequency 84 MHz	1.20 ⁽⁶⁾	1.26	1.32 ⁽⁶⁾	
		VOS[1:0] bits in PWR_CR register = 0x11 Max frequency 100 MHz	1.26	1.32	1.38	
V ₁₂	Regulator OFF: 1.2 V external voltage must be supplied on VCAP_1/VCAP_2 pins	Max frequency 64 MHz	1.10	1.14	1.20	V
		Max frequency 84 MHz	1.20	1.26	1.32	
		Max frequency 100 MHz	1.26	1.32	1.38	

Table 17. General operating conditions (continued)

Symbol	Parameter	Conditions	Min	Typ	Max	Unit
V _{IN}	Input voltage on RST, FT and TC pins ⁽⁷⁾	2 V ≤ V _{DD} ≤ 3.6 V	-0.3	-	5.5	V
		V _{DD} ≤ 2 V	-0.3	-	5.2	
	Input voltage on TTa pins	-	-0.3	-	V _{DDA} + 0.3	
	Input voltage on BOOT0 pin	-	0	-	9	
P _D	Power dissipation at TA = 85°C for range 6 or TA = 105°C for range 7 ⁽⁸⁾	UFQFPN48	-	-	625	mW
		WLCSP81	-	-	504	
		LQFP64	-	-	426	
		LQFP100	-	-	465	
		LQFP144	-	-	571	
		UFBGA100	-	-	351	
		UFBGA144	-	-	417	
	Power dissipation at TA = 125°C for range 3 ⁽⁸⁾	UFQFPN48	-	-	156	
		WLCSP81	-	-	126	
		LQFP64	-	-	106	
		LQFP100	-	-	116	
		LQFP144	-	-	143	
		UFBGA100	-	-	088	
		UFBGA144	-	-	104	
T _A	Ambient temperature for range 6	Maximum power dissipation	-40	-	85	°C
		Low power dissipation ⁽⁹⁾	-40	-	105	
	Ambient temperature for range 7	Maximum power dissipation	-40	-	105	
		Low power dissipation ⁽⁹⁾	-40	-	125	
	Ambient temperature for range 3	Maximum power dissipation	-40	-	125	
		Low power dissipation ⁽⁹⁾	-40	-	130	
T _J	Junction temperature range	Range 6	-40	-	105	
		Range 7	-40	-	125	
		Range 3	-40	-	130	

1. V_{DD}/V_{DDA} minimum value of 1.7 V with the use of an external power supply supervisor (refer to [Section 3.17.2: Internal reset OFF](#)).
2. When the ADC is used, refer to [Table 75: ADC characteristics](#).
3. If V_{REF+} pin is present, it must respect the following condition: V_{DDA}-V_{REF+} < 1.2 V.
4. It is recommended to power V_{DD} and V_{DDA} from the same source. A maximum difference of 300 mV between V_{DD} and V_{DDA} can be tolerated during power-up and power-down operation.
5. Only the DM (P_{A11}) and DP (P_{A12}) pads are supplied through V_{DDUSB}. For application where the V_{BUS} (P_{A9}) is directly connected to the chip, a minimum V_{DD} supply of 2.7V is required. (some application examples are shown in appendix B)
6. Guaranteed by test in production
7. To sustain a voltage higher than V_{DD}+0.3, the internal Pull-up and Pull-Down resistors must be disabled

- 8. If T_A is lower, higher P_D values are allowed as long as T_J does not exceed T_{Jmax} .
- 9. In low power dissipation state, T_A can be extended to this range as long as T_J does not exceed T_{Jmax} .

Table 18. Features depending on the operating power supply range

Operating power supply range	ADC operation	Maximum Flash memory access frequency with no wait states ($f_{Flashmax}$)	Maximum Flash memory access frequency with wait states ⁽¹⁾⁽²⁾	I/O operation	Clock output frequency on I/O pins ⁽³⁾	Possible Flash memory operations
$V_{DD} = 1.7$ to 2.1 V ⁽⁴⁾	Conversion time up to 1.2 Msps	16 MHz ⁽⁵⁾	100 MHz with 6 wait states	– No I/O compensation	up to 30 MHz	8-bit erase and program operations only
$V_{DD} = 2.1$ to 2.4 V	Conversion time up to 1.2 Msps	18 MHz	100 MHz with 5 wait states	– No I/O compensation	up to 30 MHz	16-bit erase and program operations
$V_{DD} = 2.4$ to 2.7 V	Conversion time up to 2.4 Msps	20 MHz	100 MHz with 4 wait states	– I/O compensation works	up to 50 MHz	16-bit erase and program operations
$V_{DD} = 2.7$ to 3.6 V ⁽⁶⁾	Conversion time up to 2.4 Msps	25 MHz	100 MHz with 3 wait states	– I/O compensation works	– up to 100 MHz when $V_{DD} = 3.0$ to 3.6 V – up to 50 MHz when $V_{DD} = 2.7$ to 3.0 V	32-bit erase and program operations

- 1. Applicable only when the code is executed from Flash memory. When the code is executed from RAM, no wait state is required.
- 2. Thanks to the ART accelerator and the 128-bit Flash memory, the number of wait states given here does not impact the execution speed from Flash memory since the ART accelerator allows to achieve a performance equivalent to 0 wait state program execution.
- 3. Refer to [Table 61: I/O AC characteristics](#) for frequencies vs. external load.
- 4. V_{DD}/V_{DDA} minimum value of 1.7 V, with the use of an external power supply supervisor (refer to [Section 3.17.2: Internal reset OFF](#)).
- 5. Prefetch available over the complete VDD supply range.
- 6. The voltage range for the USB full speed embedded PHY can drop down to 2.7 V. However the electrical characteristics of D- and D+ pins will be degraded between 2.7 and 3 V.

6.3.2 VCAP_1/VCAP_2 external capacitors

Stabilization for the main regulator is achieved by connecting the external capacitor C_{EXT} to the VCAP_1 and VCAP_2 pins. For packages supporting only 1 VCAP pin, the 2 C_{EXT} capacitors are replaced by a single capacitor.

C_{EXT} is specified in [Table 19](#).

Figure 23. External capacitor C_{EXT}

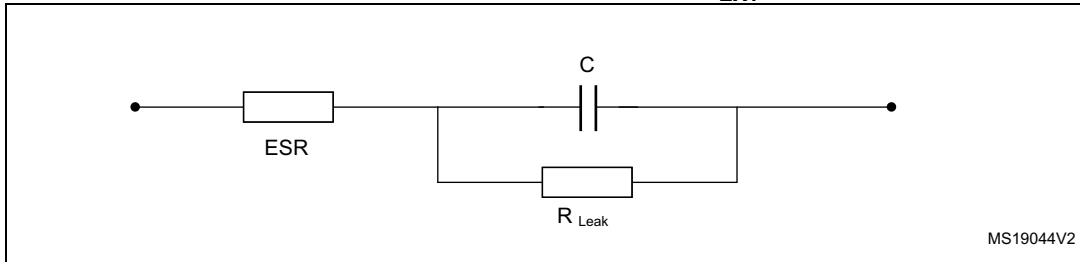

1. Legend: ESR is the equivalent series resistance.

Table 19. VCAP_1/VCAP_2 operating conditions⁽¹⁾

Symbol	Parameter	Conditions
C _{EXT}	Capacitance of external capacitor with the pins VCAP_1 and VCAP_2 available	2.2 μ F
ESR	ESR of external capacitor with the pins VCAP_1 and VCAP_2 available	< 2 Ω
C _{EXT}	Capacitance of external capacitor with a single VCAP pin available	4.7 μ F
ESR	ESR of external capacitor with a single VCAP pin available	< 1 Ω

1. When bypassing the voltage regulator, the two 2.2 μ F V_{CAP} capacitors are not required and should be replaced by two 100 nF decoupling capacitors.

6.3.3 Operating conditions at power-up/power-down (regulator ON)

Subject to general operating conditions for T_A .

Table 20. Operating conditions at power-up / power-down (regulator ON)

Symbol	Parameter	Min	Max	Unit
t_{VDD}	V_{DD} rise time rate	20	∞	μ s/V
	V_{DD} fall time rate	20	∞	

6.3.4 Operating conditions at power-up / power-down (regulator OFF)

Subject to general operating conditions for T_A .

Table 21. Operating conditions at power-up / power-down (regulator OFF)⁽¹⁾

Symbol	Parameter	Conditions	Min	Max	Unit
t_{VDD}	V_{DD} rise time rate	Power-up	20	∞	$\mu\text{s/V}$
	V_{DD} fall time rate	Power-down	20	∞	
t_{VCAP}	V_{CAP_1} and V_{CAP_2} rise time rate	Power-up	20	∞	
	V_{CAP_1} and V_{CAP_2} fall time rate	Power-down	20	∞	

1. To reset the internal logic at power-down, a reset must be applied on pin PA0 when V_{DD} reach below 1.08 V.

Note: This feature is only available for UFBGA100 and UFBGA144 packages.

6.3.5 Embedded reset and power control block characteristics

The parameters given in [Table 22](#) are derived from tests performed under ambient temperature and V_{DD} supply voltage @ 3.3V.

Table 22. Embedded reset and power control block characteristics

Symbol	Parameter	Conditions	Min	Typ	Max	Unit
V_{PVD}	Programmable voltage detector level selection	PLS[2:0]=000 (rising edge)	2.09	2.14	2.19	V
		PLS[2:0]=000 (falling edge)	1.98	2.04	2.08	
		PLS[2:0]=001 (rising edge)	2.23	2.30	2.37	
		PLS[2:0]=001 (falling edge)	2.13	2.19	2.25	
		PLS[2:0]=010 (rising edge)	2.39	2.45	2.51	
		PLS[2:0]=010 (falling edge)	2.29	2.35	2.39	
		PLS[2:0]=011 (rising edge)	2.54	2.60	2.65	
		PLS[2:0]=011 (falling edge)	2.44	2.51	2.56	
		PLS[2:0]=100 (rising edge)	2.70	2.76	2.82	
		PLS[2:0]=100 (falling edge)	2.59	2.66	2.71	
		PLS[2:0]=101 (rising edge)	2.86	2.93	2.99	
		PLS[2:0]=101 (falling edge)	2.65	2.84	3.02	
		PLS[2:0]=110 (rising edge)	2.96	3.03	3.10	
		PLS[2:0]=110 (falling edge)	2.85	2.93	2.99	
		PLS[2:0]=111 (rising edge)	3.07	3.14	3.21	
PLS[2:0]=111 (falling edge)	2.95	3.03	3.09			
$V_{PVDhyst}^{(2)}$	PVD hysteresis	-	-	100	-	mV
$V_{POR/PDR}$	Power-on/power-down reset threshold	Falling edge	1.60 ⁽¹⁾	1.68	1.76	V
		Rising edge	1.64	1.72	1.80	

Table 22. Embedded reset and power control block characteristics (continued)

Symbol	Parameter	Conditions	Min	Typ	Max	Unit
$V_{PDRhyst}^{(2)}$	PDR hysteresis	-	-	40	-	mV
V_{BOR1}	Brownout level 1 threshold	Falling edge	2.13	2.19	2.24	V
		Rising edge	2.23	2.29	2.33	
V_{BOR2}	Brownout level 2 threshold	Falling edge	2.44	2.50	2.56	
		Rising edge	2.53	2.59	2.63	
V_{BOR3}	Brownout level 3 threshold	Falling edge	2.75	2.83	2.88	
		Rising edge	2.85	2.92	2.97	
$V_{BORhyst}^{(2)}$	BOR hysteresis	-	-	100	-	mV
$T_{RSTTEMPO}^{(2)(3)}$	POR reset timing	-	0.5	1.5	3.0	ms
$I_{RUSH}^{(2)}$	In-Rush current on voltage regulator power-on (POR or wakeup from Standby)	-	-	160	200	mA
$E_{RUSH}^{(2)}$	In-Rush energy on voltage regulator power-on (POR or wakeup from Standby)	$V_{DD} = 1.7\text{ V}$, $T_A = 125\text{ °C}$, $I_{RUSH} = 171\text{ mA}$ for $31\text{ }\mu\text{s}$	-	-	5.4	μC

1. The product behavior is guaranteed by design down to the minimum $V_{POR/PDR}$ value.
2. Guaranteed by design.
3. The reset timing is measured from the power-on (POR reset or wakeup from V_{BAT}) to the instant when first instruction is fetched by the user application code.

6.3.6 Supply current characteristics

The current consumption is a function of several parameters and factors such as the operating voltage, ambient temperature, I/O pin loading, device software configuration, operating frequencies, I/O pin switching rate, program location in memory and executed binary code.

The current consumption is measured as described in [Figure 22: Current consumption measurement scheme](#).

All the run-mode current consumption measurements given in this section are performed with a reduced code that gives a consumption equivalent to CoreMark code.

Typical and maximum current consumption

The MCU is placed under the following conditions:

- All I/O pins are in input mode with a static value at VDD or VSS (no load).
- All peripherals are disabled except if it is explicitly mentioned.
- The Flash memory access time is adjusted to both f_{HCLK} frequency and VDD ranges (refer to [Table 18: Features depending on the operating power supply range](#)).
- The voltage scaling is adjusted to f_{HCLK} frequency as follows:
 - Scale 3 for f_{HCLK} ≤ 64 MHz
 - Scale 2 for 64 MHz < f_{HCLK} ≤ 84 MHz
 - Scale 1 for 84 MHz < f_{HCLK} ≤ 100 MHz
- The system clock is HCLK, f_{PCLK1} = f_{HCLK}/2, and f_{PCLK2} = f_{HCLK}.
- External clock is 4 MHz and PLL is ON except if it is explicitly mentioned.
- The maximum values are obtained for V_{DD} = 3.6 V and a maximum ambient temperature (T_A), and the typical values for T_A = 25 °C and V_{DD} = 3.3 V unless otherwise specified.

Table 23. Typical and maximum current consumption, code with data processing (ART accelerator disabled) running from SRAM - V_{DD} = 1.7 V

Symbol	Parameter	Conditions	f _{HCLK} (MHz)	Typ	Max ⁽¹⁾					Unit
				T _A = 25 °C	T _A = 25 °C	T _A =85 °C	T _A =105 °C	T _A =125 °C		
I _{DD}	Supply current in Run mode	External clock, PLL ON, all peripherals enabled ⁽²⁾⁽³⁾	100	32.9	34.96	35.30	37.21	40.79	mA	
			84	26.5	28.13	28.58	30.50	33.96		
			64	18.3	19.44	20.11	21.76	25.03		
			50	14.4	15.28	16.12	17.95	21.11		
			25	7.5	8.10	9.35	11.09	14.38		
			20	6.4	6.99	8.17	9.96	13.17		
		HSI, PLL off, all peripherals enabled ⁽²⁾⁽³⁾	16	4.6	5.17	6.42	8.28	11.46		
			1	0.7	1.28	2.64	4.30	7.66		
		External clock, PLL ON, all peripherals disabled ⁽³⁾	100	15.4	16.43	17.35	19.17	22.85		
			84	12.4	13.28	14.32	16.12	19.67		
			64	8.7	9.36	10.38	12.06	15.31		
			50	6.9	7.47	8.54	10.36	13.49		
			25	3.7	4.27	5.47	7.17	10.45		
			20	3.2	3.72	5.01	6.67	10.02		
		HSI, PLL off, all peripherals disabled ⁽³⁾	16	2.3	2.80	4.05	5.90	9.07		
			1	0.6	1.14	2.51	4.16	7.51		

1. Guaranteed by characterization results.
 2. When analog peripheral blocks such as ADC, HSE, LSE, HSI, or LSI are ON, an additional power consumption has to be considered.



- When the ADC is ON (ADON bit set in the ADC_CR2 register), add an additional power consumption of 1.6 mA for the analog part.

Table 24. Typical and maximum current consumption, code with data processing (ART accelerator disabled) running from SRAM - V_{DD} = 3.6 V

Symbol	Parameter	Conditions	f _{HCLK} (MHz)	Typ	Max ⁽¹⁾					Unit
				T _A = 25 °C	T _A = 25 °C	T _A = 85 °C	T _A = 105 °C	T _A = 125 °C		
I _{DD}	Supply current in Run mode	External clock, PLL ON, all peripherals enabled ⁽²⁾	100	33.3	35.32 ⁽³⁾	35.65	37.65	41.26 ⁽³⁾	mA	
			84	26.8	28.45 ⁽³⁾	28.97	30.82	34.39 ⁽³⁾		
			64	18.6	19.74 ⁽³⁾	20.35	22.11	25.35 ⁽³⁾		
			50	14.6	15.57	16.41	18.21	21.46		
			25	7.8	8.37	9.64	11.32	14.68		
			20	6.7	7.25	8.40	10.25	13.45		
		HSI, PLL OFF ⁽⁴⁾ , all peripherals enabled ⁽²⁾	16	4.6	4.96	6.39	8.20	11.54		
			1	0.8	0.86	2.51	4.34	7.65		
		External clock, PLL ON, all peripherals disabled ⁽²⁾	100	15.7	16.74 ⁽³⁾	17.62	19.50	23.16 ⁽³⁾		
			84	12.7	13.57 ⁽³⁾	14.60	16.38	19.98 ⁽³⁾		
			64	9.0	9.62 ⁽³⁾	10.60	12.37	15.58 ⁽³⁾		
			50	7.1	7.69	8.79	10.63	13.79		
			25	4.0	4.52	5.68	7.44	10.68		
			20	3.4	4.03	5.23	6.90	10.27		
		HSI, PLL OFF, all peripherals disabled ⁽²⁾	16	2.3	2.44	4.00	5.81	9.13		
			1	0.6	0.70	2.35	4.18	7.49		

- Guaranteed by characterization results.
- When the ADC is ON (ADON bit set in the ADC_CR2 register), add an additional power consumption of 1.6 mA for the analog part.
- Tested in production
- When analog peripheral blocks such as ADC, HSE, LSE, HSI, or LSI are ON, an additional power consumption has to be considered

Table 25. Typical and maximum current consumption in run mode, code with data processing (ART accelerator enabled except prefetch) running from Flash memory- V_{DD} = 1.7 V

Symbol	Parameter	Conditions	f _{HCLK} (MHz)	Typ	Max ⁽¹⁾					Unit
				T _A = 25 °C	T _A = 25 °C	T _A = 85 °C	T _A = 105 °C	T _A = 125 °C		
I _{DD}	Supply current in Run mode	External clock, PLL ON, all peripherals enabled ⁽²⁾⁽³⁾	100	30.2	32.03	32.71	34.69	38.46	mA	
			84	24.3	25.77	26.58	28.47	32.16		
			64	16.8	17.80	18.66	20.53	23.85		
			50	13.2	14.05	15.12	16.85	20.27		
			25	7.1	7.62	8.92	10.81	14.11		
			20	6.1	6.69	7.95	9.72	13.09		
		HSI, PLL OFF, all peripherals enabled ⁽²⁾	16	4.4	4.99	6.28	8.18	11.45		
			1	0.9	1.50	2.88	4.58	8.00		
		External clock, PLL ON ⁽⁴⁾ all peripherals disabled ⁽²⁾	100	12.6	13.46	14.75	16.68	20.54		
			84	10.2	10.90	12.25	14.10	17.84		
			64	7.2	7.70	8.95	10.81	14.14		
			50	5.7	6.26	7.56	9.26	12.72		
			25	3.2	3.77	5.11	6.82	10.26		
			20	2.9	3.41	4.79	6.49	9.92		
		HSI, PLL OFF, all peripherals disabled ⁽²⁾	16	2.1	2.63	3.91	5.80	9.06		
			1	0.8	1.34	2.72	4.42	7.86		

1. Guaranteed by characterization results..
2. Add an additional power consumption of 1.6 mA per ADC for the analog part. In applications, this consumption occurs only while the ADC is ON (ADON bit is set in the ADC_CR2 register).
3. When the ADC is ON (ADON bit set in the ADC_CR2), add an additional power consumption of 1.6mA per ADC for the analog part.
4. Refer to [Table 47](#) and RM0383 for the possible PLL VCO setting

Table 26. Typical and maximum current consumption in run mode, code with data processing (ART accelerator enabled except prefetch) running from Flash memory - V_{DD} = 3.6 V

Symbol	Parameter	Conditions	f _{HCLK} (MHz)	Typ	Max ⁽¹⁾					Unit
				T _A = 25 °C	T _A = 25 °C	T _A = 85 °C	T _A = 105 °C	T _A = 125 °C		
I _{DD}	Supply current in Run mode	External clock, PLL ON ⁽²⁾ , all peripherals enabled ⁽³⁾	100	30.7	32.85 ⁽⁴⁾	33.30	35.37	39.08	mA	
			84	24.7	26.48	27.15	28.94	32.65		
			64	17.2	18.36	19.14	20.88	24.29		
			50	13.6	14.54	15.45	17.27	20.58		
			25	7.4	7.97	9.23	11.05	14.42		
			20	6.4	6.99	8.18	10.03	13.32		
		HSI, PLL OFF, all peripherals enabled ⁽³⁾	16	4.5	5.04	6.32	8.23	11.50		
			1	1.0	1.50	2.89	4.59	8.01		
		External clock, PLL ON ⁽²⁾ all peripherals disabled ⁽³⁾	100	13.1	14.36	15.33	17.25	20.98		
			84	10.7	11.67	12.73	14.56	18.21		
			64	7.5	8.23	9.40	11.13	14.52		
			50	6.1	6.74	7.89	9.61	12.98		
			25	3.5	4.19	5.37	7.08	10.48		
			20	3.2	3.71	5.02	6.72	10.15		
		HSI, PLL OFF, all peripherals disabled ⁽³⁾	16	2.1	2.67	3.95	5.84	9.10		
			1	0.8	1.35	2.72	4.43	7.87		

1. Guaranteed by characterization results.
2. Refer to [Table 47](#) and RM0383 for the possible PLL VCO setting
3. Add an additional power consumption of 1.6 mA per ADC for the analog part. In applications, this consumption occurs only while the ADC is ON (ADON bit is set in the ADC_CR2 register).
4. Tested in production.

Table 27. Typical and maximum current consumption in run mode, code with data processing (ART accelerator disabled) running from Flash memory - V_{DD} = 3.6 V

Symbol	Parameter	Conditions	f _{HCLK} (MHz)	Typ	Max ⁽¹⁾					Unit
				T _A = 25 °C	T _A = 25 °C	T _A = 85 °C	T _A = 105 °C	T _A = 125 °C		
I _{DD}	Supply current in Run mode	External clock, PLL ON ⁽²⁾ , all peripherals enabled ⁽³⁾	100	39.9	42.46	43.17	45.32	49.19	mA	
			84	32.6	34.71	35.45	37.58	41.24		
			64	24.2	25.86	26.73	28.47	31.96		
			50	19.7	21.01	22.00	23.74	27.26		
			25	10.8	11.55	12.83	14.66	18.03		
			20	9.2	9.82	11.16	13.09	16.36		
		HSI, PLL OFF, all peripherals enabled ⁽³⁾	16	6.8	7.33	8.77	10.69	14.00		
			1	1.2	1.83	3.08	4.83	8.19		
		External clock, PLL ON ⁽²⁾ , all peripherals disabled ⁽³⁾	100	22.3	24.11	25.26	27.35	31.11		
			84	18.5	20.00	21.15	23.20	26.87		
			64	14.6	15.81	17.02	18.74	22.20		
			50	12.2	13.14	14.45	16.18	19.66		
			25	7.0	7.52	8.95	10.84	14.19		
			20	6.0	6.58	7.95	9.74	13.07		
		HSI, PLL OFF, all peripherals disabled ⁽³⁾	16	4.5	4.97	6.40	8.30	11.59		
			1	1.0	1.61	2.94	4.65	8.05		

1. Guaranteed by characterization results.
2. Refer to [Table 47](#) and RM0383 for the possible PLL VCO setting
3. Add an additional power consumption of 1.6 mA per ADC for the analog part. In applications, this consumption occurs only while the ADC is ON (ADON bit is set in the ADC_CR2 register).

Table 28. Typical and maximum current consumption in run mode, code with data processing (ART accelerator disabled) running from Flash memory - V_{DD} = 1.7 V

Symbol	Parameter	Conditions	f _{HCLK} (MHz)	Typ	Max ⁽¹⁾					Unit
				T _A = 25 °C	T _A = 25 °C	T _A = 85 °C	T _A = 105 °C	T _A = 125 °C		
I _{DD}	Supply current in Run mode	External clock, PLL ON, all peripherals enabled ⁽²⁾⁽³⁾	100	36.1	38.48	39.08	40.91	44.59	mA	
			84	30.6	32.60	33.14	35.10	38.56		
			64	23.9	25.67	26.27	27.94	31.19		
			50	18.9	20.32	21.04	22.85	26.10		
			25	10.8	11.63	12.75	14.56	17.87		
			20	9.2	9.84	11.06	12.98	16.23		
		HSI, PLL OFF, all peripherals enabled ⁽²⁾⁽³⁾	16	7.1	7.69	9.02	10.87	14.25		
			1	1.2	1.84	3.10	4.84	8.20		
		External clock, PLL ON ⁽³⁾ all peripherals disabled	100	18.6	20.33	21.23	23.15	26.71		
			84	16.5	18.09	19.01	20.81	24.29		
			64	14.3	15.76	16.67	18.28	21.50		
			50	11.5	12.57	13.53	15.33	18.49		
			25	7.0	7.67	8.90	10.76	14.05		
			20	6.0	6.68	7.87	9.65	12.96		
		HSI, PLL OFF, all peripherals disabled ⁽³⁾	16	4.8	5.33	6.66	8.49	11.86		
			1	1.0	1.62	2.95	4.66	8.06		

1. Guaranteed by characterization results.
2. Add an additional power consumption of 1.6 mA per ADC for the analog part. In applications, this consumption occurs only while the ADC is ON (ADON bit is set in the ADC_CR2 register).
3. When the ADC is ON (ADON bit set in the ADC_CR2), add an additional power consumption of 1.6mA per ADC for the analog part.

Table 29. Typical and maximum current consumption in run mode, code with data processing (ART accelerator enabled with prefetch) running from Flash memory - V_{DD} = 3.6 V

Symbol	Parameter	Conditions	f _{HCLK} (MHz)	Typ	Max ⁽¹⁾					Unit
				T _A = 25 °C	T _A = 25 °C	T _A = 85 °C	T _A = 105 °C	T _A = 125 °C		
I _{DD}	Supply current in Run mode	External clock, PLL ON, all peripherals enabled ⁽²⁾	100	42.3	45.08	45.76	47.88	51.71	mA	
			84	34.6	36.87	37.58	39.64	43.32		
			64	25.5	27.18	27.93	29.90	33.23		
			50	20.2	21.55	22.50	24.34	27.73		
			25	10.9	11.61	12.87	14.72	18.08		
			20	9.3	9.86	11.20	13.13	16.41		
		HSI, PLL OFF, all peripherals enabled	16	6.9	7.37	8.81	10.72	14.04		
			1	1.2	1.83	3.09	4.83	8.19		
		External clock, PLL ON ⁽²⁾ all peripherals disabled	100	24.7	26.76	27.84	29.93	33.66		
			84	20.5	22.18	23.25	25.33	28.98		
			64	15.9	17.13	18.23	20.18	23.46		
			50	12.7	13.68	14.95	16.71	20.13		
			25	7.1	7.57	9.01	10.88	14.25		
			20	6.1	6.61	7.98	9.80	13.11		
		HSI, PLL OFF, all peripherals disabled	16	4.5	5.00	6.44	8.33	11.63		
			1	1.0	1.61	2.94	4.65	8.06		

1. Guaranteed by characterization results.
2. Add an additional power consumption of 1.6 mA per ADC for the analog part. In applications, this consumption occurs only while the ADC is ON (ADON bit is set in the ADC_CR2 register).

Table 30. Typical and maximum current consumption in run mode, code with data processing (ART accelerator enabled with prefetch) running from Flash memory - $V_{DD} = 1.7\text{ V}$

Symbol	Parameter	Conditions	f_{HCLK} (MHz)	Typ	Max ⁽¹⁾					Unit
				$T_A = 25\text{ °C}$	$T_A = 25\text{ °C}$	$T_A = 85\text{ °C}$	$T_A = 105\text{ °C}$	$T_A = 125\text{ °C}$		
I_{DD}	Supply current in Run mode	External clock, PLL ON, all peripherals enabled ⁽²⁾	100	42.9	45.86	45.76	47.88	51.71	mA	
			84	35.4	37.90	38.16	40.01	43.26		
			64	26.2	28.19	28.74	30.37	33.54		
			50	20.7	22.32	22.50	24.34	27.73		
			25	11.1	11.87	12.87	14.72	18.08		
			20	9.4	10.05	11.26	13.16	16.46		
		HSI, PLL OFF, all peripherals enabled	16	7.1	7.72	9.06	10.90	14.29		
			1	1.2	1.84	3.10	4.84	8.20		
		External clock, PLL ON ⁽²⁾ all peripherals disabled	100	25.4	27.83	27.84	29.93	33.66		
			84	21.4	23.44	24.10	25.77	29.04		
			64	16.6	18.31	19.17	20.72	23.86		
			50	13.2	15.10	14.95	16.71	20.13		
			25	7.2	7.90	9.01	10.88	14.25		
			20	6.2	6.83	8.05	9.88	13.15		
		HSI, PLL OFF, all peripherals disabled	16	4.8	5.37	6.70	8.52	11.89		
			1	1.0	1.62	2.96	4.67	8.07		

1. Guaranteed by characterization results.
2. Add an additional power consumption of 1.6 mA per ADC for the analog part. In applications, this consumption occurs only while the ADC is ON (ADON bit is set in the ADC_CR2 register).

Table 31. Typical and maximum current consumption in Sleep mode - V_{DD} = 3.6 V

Symbol	Parameter	Conditions	f _{HCLK} (MHz)	Typ	Max ⁽¹⁾					Unit
				T _A = 25 °C	T _A = 25 °C	T _A = 85 °C	T _A = 105 °C	T _A = 125 °C		
I _{DD}	Supply current in Sleep mode	All peripherals enabled ⁽²⁾⁽³⁾ , External clock, PLL ON, Flash deep power down	100	21.6	22.97 ⁽⁴⁾	23.91	25.99	29.72	mA	
			84	17.4	18.50	19.59	21.42	25.09		
			64	12.0	12.81	13.87	15.73	19.00		
			50	9.5	10.15	11.33	13.22	16.44		
			25	5.2	5.79	7.11	8.82	12.18		
			20	4.6	5.17	6.41	8.28	11.48		
		All peripherals enabled ⁽²⁾⁽³⁾ , HSI, PLL OFF, Flash deep power down	16	3.0	3.24	4.78	6.60	9.94		
			1	0.7	0.76	2.41	4.23	7.55		
		All peripherals enabled ⁽²⁾⁽³⁾ , External clock, PLL ON Flash ON	100	22.0	23.42	24.45	26.41	30.24		
			84	17.7	18.91	19.98	21.85	25.56		
			64	12.4	13.17	14.30	16.07	19.48		
			50	9.8	10.48	11.72	13.53	16.90		
			25	5.5	6.05	7.41	9.11	12.55		
			20	4.9	5.42	6.72	8.57	11.89		
		All peripherals enabled ⁽²⁾⁽³⁾ , HSI, PLL ON, Flash ON	16	3.3	3.51	5.06	6.91	10.30		
			1	0.9	1.01	2.67	4.52	7.88		
		All peripherals disabled, External clock, PLL ON ⁽²⁾ , Flash deep power down	100	3.5	4.17	5.56	7.54	11.23		
			84	2.9	3.48	4.94	6.76	10.40		
			64	2.2	2.73	3.94	5.80	8.98		
			50	1.8	2.38	3.57	5.42	8.60		
			25	1.3	1.86	3.11	4.82	8.12		
			20	1.3	1.90	3.13	4.85	8.15		
		All peripherals disabled, HSI, PLL OFF ⁽²⁾ , Flash deep power down	16	0.6	0.68	2.33	4.16	7.47		
			1	0.5	0.59	2.24	4.07	7.38		
		All peripherals disabled, External clock, PLL ON ⁽²⁾ , Flash ON	100	4.0	4.54	5.97	8.09	11.74		
			84	3.3	3.87	5.32	7.19	10.84		
			64	2.5	3.04	4.33	6.15	9.47		
			50	2.2	2.69	3.93	5.82	9.04		
			25	1.6	2.13	3.37	5.20	8.46		
			20	1.6	2.16	3.39	5.22	8.48		
		All peripherals disabled, HSI, PLL OFF ⁽²⁾ , Flash ON	16	0.9	0.96	2.62	4.47	7.82		
			1	0.7	0.85	2.50	4.36	7.71		

1. Guaranteed by characterization results.
2. Add an additional power consumption of 1.6 mA per ADC for the analog part. In applications, this consumption occurs only while the ADC is ON (ADON bit is set in the ADC_CR2 register).
3. When the ADC is ON (ADON bit set in the ADC_CR2), add an additional power consumption of 1.6mA per ADC for the analog part.
4. Tested in production.



Table 32. Typical and maximum current consumption in Sleep mode - V_{DD} = 1.7 V

Symbol	Parameter	Conditions	f _{HCLK} (MHz)	Typ	Max ⁽¹⁾					Unit
				T _A = 25 °C	T _A = 25 °C	T _A = 85 °C	T _A = 105 °C	T _A = 125 °C		
I _{DD}	Supply current in Sleep mode	External clock, PLL ON, Flash deep power down, all peripherals enabled ⁽²⁾	100	21.2	22.64	23.56	25.66	29.30	mA	
			84	17.1	18.20	19.27	21.14	24.75		
			64	11.8	12.53	13.59	15.47	18.66		
			50	9.3	9.88	11.06	12.94	16.11		
			25	5.0	5.52	6.83	8.61	11.88		
			20	4.4	4.93	6.16	8.03	11.19		
		HSI, PLL OFF ⁽²⁾ , Flash deep power down, all peripherals enabled	16	3.0	3.53	4.91	6.57	9.94		
			1	0.6	1.19	2.55	4.21	7.57		
		External clock, PLL ON ⁽²⁾ , all peripherals enabled, Flash ON	100	21.7	23.10	24.09	26.12	29.90		
			84	17.4	18.61	19.72	21.55	25.27		
			64	12.1	12.89	13.98	15.84	19.18		
			50	9.6	10.20	11.43	13.32	16.62		
			25	5.2	5.80	7.19	8.91	12.33		
			20	4.6	5.18	6.47	8.37	11.63		
		HSI, PLL OFF ⁽²⁾ , all peripherals enabled, Flash ON	16	3.2	3.79	5.17	6.88	10.32		
			1	0.9	1.43	2.80	4.50	7.92		
		All peripherals disabled, External clock, PLL ON ⁽²⁾ , Flash deep power down	100	3.3	3.82	5.34	7.25	10.97		
			84	2.7	3.22	4.70	6.54	10.13		
			64	1.9	2.48	3.70	5.55	8.71		
			50	1.6	2.13	3.35	5.15	8.35		
			25	1.0	1.61	2.90	4.57	7.91		
			20	1.1	1.66	2.93	4.59	7.93		
		All peripherals disabled, HSI, PLL OFF ⁽²⁾ , Flash deep power down	16	0.6	1.12	2.49	4.14	7.49		
			1	0.5	1.04	2.40	4.06	7.40		
		All peripherals disabled, External clock, PLL ON ⁽²⁾ , Flash ON	100	3.7	4.28	5.76	7.83	11.49		
			84	3.1	3.60	5.11	6.96	10.64		
			64	2.3	2.80	4.09	5.96	9.23		
			50	1.9	2.44	3.70	5.59	8.82		
			25	1.3	1.89	3.18	4.94	8.27		
			20	1.4	1.92	3.20	4.97	8.29		
All peripherals disabled, HSI, PLL OFF ⁽²⁾ , Flash ON	16	0.8	1.38	2.75	4.44	7.87				
	1	0.7	1.25	2.65	4.34	7.77				

1. Guaranteed by characterization results.

2. Add an additional power consumption of 1.6 mA per ADC for the analog part. In applications, this consumption occurs only while the ADC is ON (ADON bit is set in the ADC_CR2 register).

Table 33. Typical and maximum current consumptions in Stop mode - V_{DD} = 1.7 V

Symbol	Conditions	Parameter	Typ ⁽¹⁾	Max ⁽¹⁾					Unit
			T _A = 25 °C	T _A = 25 °C	T _A = 85 °C	T _A = 105 °C	T _A = 125 °C		
I _{DD_STOP}	Flash in Stop mode, all oscillators OFF, no independent watchdog	Main regulator usage	111.7	157.9	713.7	1323.5	2315.1	µA	
		Low power regulator usage	42.3	80.1	594.1	1167.6	2097.6		
	Flash in Deep power down mode, all oscillators OFF, no independent watchdog	Main regulator usage	77.9	113.1	568.3	1073.6	1883.7		
		Low power regulator usage	19.7	55.8	561.3	1123.2	2026.0		
		Low power low voltage regulator usage	15.3	46.3	490.8	991.3	1793.9		

1. Guaranteed by characterization results.

Table 34. Typical and maximum current consumption in Stop mode - V_{DD}=3.6 V

Symbol	Conditions	Parameter	Typ	Max ⁽¹⁾					Unit
			T _A = 25 °C	T _A = 25 °C	T _A = 85 °C	T _A = 105 °C	T _A = 125 °C		
I _{DD_STOP}	Flash in Stop mode, all oscillators OFF, no independent watchdog	Main regulator usage	114.4	161.6 ⁽²⁾	723.0	1339.0	2342.7 ⁽²⁾	µA	
		Low power regulator usage	44.1	82.5 ⁽²⁾	600.6	1179.3	2119.1		
	Flash in Deep power down mode, all oscillators OFF, no independent watchdog	Main regulator usage	80.6	116.7	572.3	1079.2	1896.3		
		Low power regulator usage	21.4	58.9	567.9	1134.5	2049.6		
		Low power low voltage regulator usage	17.0	49.0 ⁽²⁾	497.4	1003.6	1817.0 ⁽²⁾		

1. Guaranteed by characterization results.
2. Tested in production.

Table 35. Typical and maximum current consumption in Standby mode - V_{DD}= 1.7 V

Symbol	Parameter	Conditions	Typ ⁽¹⁾	Max ⁽²⁾					Unit
			T _A = 25 °C	T _A = 25 °C	T _A = 85 °C	T _A = 105 °C	T _A = 125 °C		
I _{DD_STBY}	Supply current in Standby mode	Low-speed oscillator (LSE in low drive mode) and RTC ON	2.3	3.7	15.9	32.5	76.8	µA	
		Low-speed oscillator (LSE in high drive mode) and RTC ON	2.9	4.3	16.5	33.1	77.4		
		RTC and LSE OFF	1.1	2.5	14.7	31.3	75.6		

1. When the PDR is OFF (internal reset is OFF), the typical current consumption is reduced by 1.2 µA.
2. Guaranteed by characterization results.

Table 36. Typical and maximum current consumption in Standby mode - $V_{DD} = 3.6\text{ V}$

Symbol	Parameter	Conditions	Typ ⁽¹⁾	Max ⁽²⁾					Unit
			$T_A = 25\text{ °C}$	$T_A = 25\text{ °C}$	$T_A = 85\text{ °C}$	$T_A = 105\text{ °C}$	$T_A = 125\text{ °C}$		
I_{DD_STBY}	Supply current in Standby mode	Low-speed oscillator (LSE in low drive mode) and RTC ON	3.7	5.2	20.6	40.5	82.7	μA	
		Low-speed oscillator (LSE in high drive mode) and RTC ON	4.5	6.0	21.4	41.3	83.5		
		RTC and LSE OFF	2.5	4.0	19.4	39.3	81.5 ⁽³⁾		

1. When the PDR is OFF (internal reset is OFF), the typical current consumption is reduced by 1.2 μA .
2. Guaranteed by characterization, not tested in production unless otherwise specified.
3. Tested in production.

Table 37. Typical and maximum current consumptions in V_{BAT} mode

Symbol	Parameter	Conditions ⁽¹⁾	Typ				Max ⁽²⁾			Unit
			$T_A = 25\text{ °C}$				$T_A = 85\text{ °C}$	$T_A = 105\text{ °C}$	$T_A = 125\text{ °C}$	
			$V_{BAT} = 1.7\text{ V}$	$V_{BAT} = 2.4\text{ V}$	$V_{BAT} = 3.3\text{ V}$	$V_{BAT} = 3.6\text{ V}$	$V_{BAT} = 3.6\text{ V}$			
I_{DD_VBAT}	Backup domain supply current	Low-speed oscillator (LSE in low-drive mode) and RTC ON	0.74	0.84	1.04	1.24	3.00	5.00	10.00	μA
		Low-speed oscillator (LSE in high-drive mode) and RTC ON	1.51	1.64	1.89	2.00	3.80	5.80	11.60	
		RTC and LSE OFF	0.03	0.03	0.04	0.04	2.00	4.00	8.00	

1. Crystal used: Abracon ABS07-120-32.768 kHz-T with a C_L of 6 pF for typical values.
2. Guaranteed by characterization results.

Figure 24. Typical V_{BAT} current consumption (LSE and RTC ON/LSE oscillator “low power” mode selection)

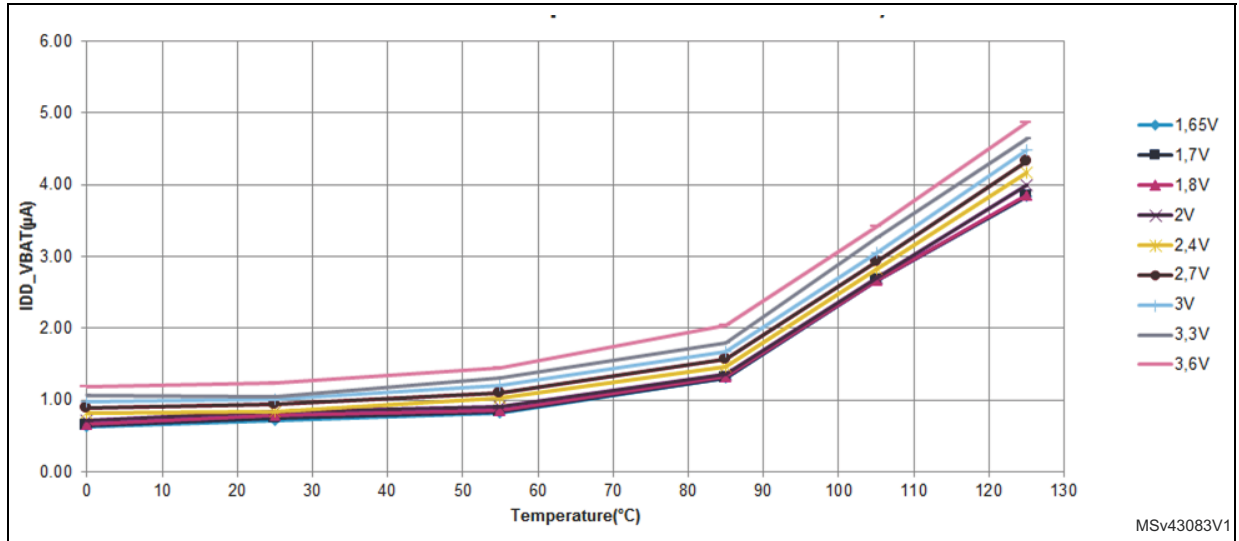
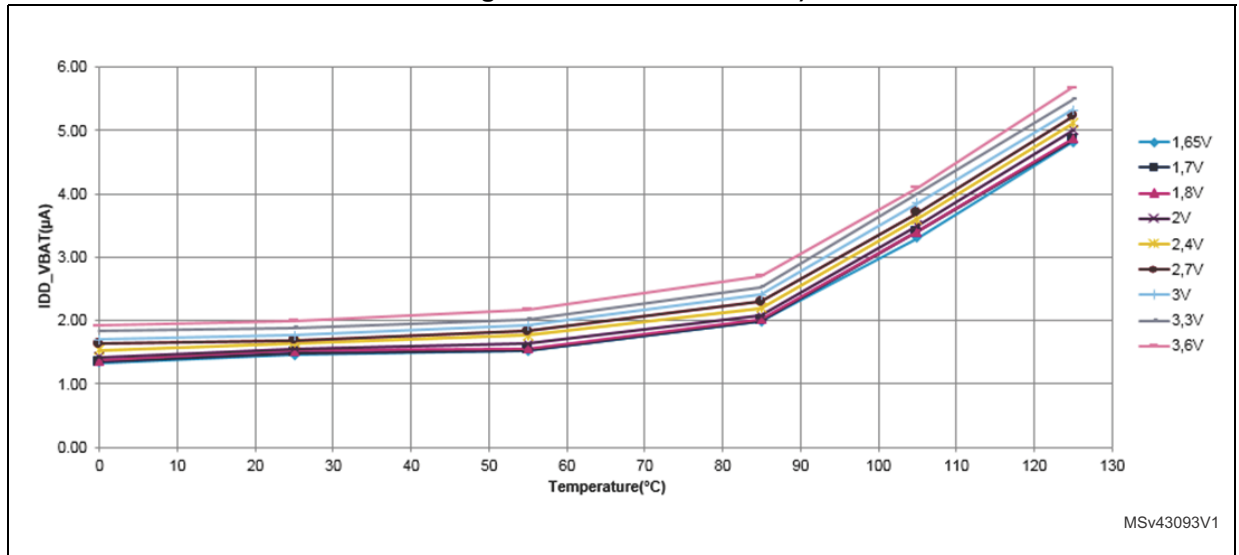

Figure 25. Typical V_{BAT} current consumption (LSE and RTC ON/LSE oscillator “high drive” mode selection)



I/O system current consumption

The current consumption of the I/O system has two components: static and dynamic.

I/O static current consumption

All the I/Os used as inputs with pull-up generate current consumption when the pin is externally held low. The value of this current consumption can be simply computed by using the pull-up/pull-down resistors values given in [Table 59: I/O static characteristics](#).

For the output pins, any external pull-down or external load must also be considered to estimate the current consumption.

Additional I/O current consumption is due to I/Os configured as inputs if an intermediate voltage level is externally applied. This current consumption is caused by the input Schmitt trigger circuits used to discriminate the input value. Unless this specific configuration is required by the application, this supply current consumption can be avoided by configuring these I/Os in analog mode. This is notably the case of ADC input pins which should be configured as analog inputs.

Caution: Any floating input pin can also settle to an intermediate voltage level or switch inadvertently, as a result of external electromagnetic noise. To avoid current consumption related to floating pins, they must either be configured in analog mode, or forced internally to a definite digital value. This can be done either by using pull-up/down resistors or by configuring the pins in output mode.

I/O dynamic current consumption

In addition to the internal peripheral current consumption (see [Table 39: Peripheral current consumption](#)), the I/Os used by an application also contribute to the current consumption. When an I/O pin switches, it uses the current from the MCU supply voltage to supply the I/O pin circuitry and to charge/discharge the capacitive load (internal or external) connected to the pin:

$$I_{SW} = V_{DD} \times f_{SW} \times C$$

where

I_{SW} is the current sunk by a switching I/O to charge/discharge the capacitive load

V_{DD} is the MCU supply voltage

f_{SW} is the I/O switching frequency

C is the total capacitance seen by the I/O pin: $C = C_{INT} + C_{EXT}$

The test pin is configured in push-pull output mode and is toggled by software at a fixed frequency.

Table 38. Switching output I/O current consumption

Symbol	Parameter	Conditions ⁽¹⁾	I/O toggling frequency (f _{sw})	Typ	Unit
IDDIO	I/O switching current	V _{DD} = 3.3 V C = C _{INT}	2 MHz	0.05	mA
			8 MHz	0.15	
			25 MHz	0.45	
			50 MHz	0.85	
			60 MHz	1.00	
			84 MHz	1.40	
			90 MHz	1.67	
		V _{DD} = 3.3 V C _{EXT} = 0 pF C = C _{INT} + C _{EXT} + C _S	2 MHz	0.10	
			8 MHz	0.35	
			25 MHz	1.05	
			50 MHz	2.20	
			60 MHz	2.40	
			84 MHz	3.55	
			90 MHz	4.23	
		V _{DD} = 3.3 V C _{EXT} = 10 pF C = C _{INT} + C _{EXT} + C _S	2 MHz	0.20	
			8 MHz	0.65	
			25 MHz	1.85	
			50 MHz	2.45	
			60 MHz	4.70	
			84 MHz	8.80	
		V _{DD} = 3.3 V C _{EXT} = 22 pF C = C _{INT} + C _{EXT} + C _S	90 MHz	10.47	
			2 MHz	0.25	
			8 MHz	1.00	
			25 MHz	3.45	
		V _{DD} = 3.3 V C _{EXT} = 33 pF C = C _{INT} + C _{EXT} + C _S	50 MHz	7.15	
			60 MHz	11.55	
			2 MHz	0.32	
			8 MHz	1.27	
			25 MHz	3.88	
			50 MHz	12.34	

1. CS is the PCB board capacitance including the pad pin. CS = 7 pF (estimated value).

On-chip peripheral current consumption

The MCU is placed under the following conditions:

- At startup, all I/O pins are in analog input configuration.
- All peripherals are disabled unless otherwise mentioned.
- The ART accelerator is ON.
- Voltage Scale 2 mode selected, internal digital voltage V12 = 1.26 V.
- HCLK is the system clock at 100 MHz. $f_{PCLK1} = f_{HCLK}/2$, and $f_{PCLK2} = f_{HCLK}$.
The given value is calculated by measuring the difference of current consumption
 - with all peripherals clocked off,
 - with only one peripheral clocked on,
 - scale 1 with $f_{HCLK} = 100$ MHz,
 - scale 2 with $f_{HCLK} = 84$ MHz,
 - scale 3 with $f_{HCLK} = 64$ MHz.
- Ambient operating temperature is 25 °C and $V_{DD}=3.3$ V.

Table 39. Peripheral current consumption

Peripheral		I _{DD} (Typ)			Unit
		Scale 1	Scale 2	Scale 3	
AHB1	GPIOA	1.89	1.82	1.64	μA/MHz
	GPIOB	1.75	1.68	1.52	
	GPIOC	1.70	1.64	1.48	
	GPIOD	1.72	1.65	1.48	
	GPIOE	1.78	1.71	1.55	
	GPIOF	1.68	1.62	1.45	
	GPIOG	1.66	1.61	1.44	
	GPIOH	0.72	0.69	0.63	
	CRC	0.30	0.30	0.28	
	DMA1 ⁽¹⁾	1.75N + 3.14	1.66N + 3.00	1.49N + 2.70	
DMA2 ⁽¹⁾	1.79N + 3.29	1.71N + 3.14	1.53N + 2.82		
AHB2	RNG	0.72	0.70	0.63	μA/MHz
	USB_OTG_FS	19.26	18.37	16.47	
AHB3	FSMC	5.42	5.18	4.64	μA/MHz
	QSPI	10.33	9.86	8.84	

Table 39. Peripheral current consumption (continued)

Peripheral		I _{DD} (Typ)			Unit
		Scale 1	Scale 2	Scale 3	
APB1	AHB-APB1 bridge	0.90	0.88	0.81	μA/MHz
	TIM2	13.08	12.48	11.16	
	TIM3	9.98	9.50	8.50	
	TIM4	9.88	9.43	8.44	
	TIM5	13.14	12.52	11.19	
	TIM6	1.94	1.86	1.66	
	TIM7	1.86	1.79	1.56	
	TIM12	5.56	5.29	4.72	
	TIM13	3.44	3.29	2.94	
	TIM14	3.66	3.48	3.09	
	LPTIM1	7.34	7.00	6.25	
	WWDG	0.64	0.62	0.53	
	SPI2/I2S2	3.02	2.88	2.56	
	SPI3/I2S3	3.06	2.90	2.59	
	USART2	3.30	3.14	2.81	
	USART3	3.32	3.14	2.81	
	UART4	3.18	3.02	2.69	
	UART5	3.26	3.10	2.75	
	I2C1	3.20	3.05	2.72	
	I2C2	3.30	3.14	2.81	
	I2C3	3.26	3.10	2.78	
	I2CFMP1	5.22	4.98	4.44	
	CAN1	5.58	5.31	4.75	
	CAN2	5.14	4.88	4.38	
	CAN3	5.70	5.43	4.84	
	PWR	0.90	0.86	0.75	
DAC1	2.14	2.05	1.81		
UART7	3.08	2.93	2.59		
UART8	3.10	2.95	2.63		

Table 39. Peripheral current consumption (continued)

Peripheral		I _{DD} (Typ)			Unit
		Scale 1	Scale 2	Scale 3	
APB2	AHB-APB2 bridge	0.10	0.11	0.09	μA/MHz
	TIM1	6.78	6.46	5.80	
	TIM8	6.94	6.62	5.94	
	USART1	3.14	3.00	2.69	
	USART6	3.12	2.98	2.67	
	UART9	2.89	1.98	1.75	
	UART10	2.91	2.00	1.77	
	ADC1	3.45	3.29	2.95	
	SDIO	3.54	3.37	3.03	
	SPI1	1.52	1.46	1.31	
	SPI4	1.50	1.43	1.28	
	SYSCFG	0.58	0.55	0.50	
	EXT1	0.91	0.86	0.78	
	TIM9	2.95	2.81	2.53	
	TIM10	1.88	1.79	1.61	
	TIM11	1.86	1.77	1.59	
	SPI5	1.50	1.43	1.30	
	SAI	2.89	2.75	2.47	
	DFSDM1	4.43	4.21	3.80	
DFSDM2	7.08	6.76	6.05		
Bus Matrix		4.06	3.87	3.45	

1. N is the number of stream enable (1...8).

6.3.7 Wakeup time from low-power modes

The wakeup times given in [Table 40](#) are measured starting from the wakeup event trigger up to the first instruction executed by the CPU:

- For Stop or Sleep modes: the wakeup event is WFE.
- WKUP (PA0/PC0/PC1) pins are used to wakeup from Standby, Stop and Sleep modes.

Figure 26. Low-power mode wakeup

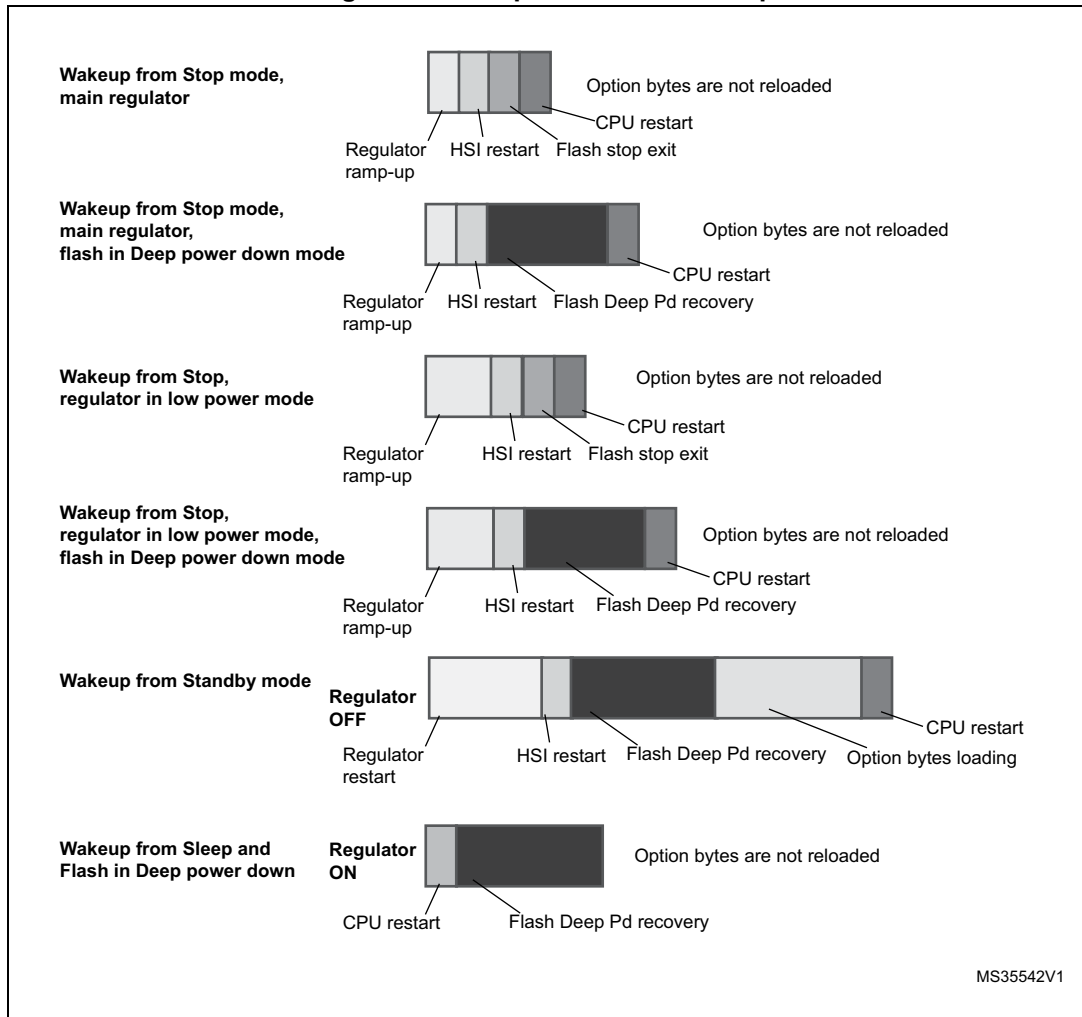

All timings are derived from tests performed under ambient temperature and $V_{DD}=3.3$ V.

Table 40. Low-power mode wakeup timings⁽¹⁾

Symbol	Parameter	Conditions	Min ⁽¹⁾	Typ ⁽¹⁾	Max ⁽¹⁾	Unit
$t_{WUSLEEP}$	Wakeup from Sleep mode	-	-	4	6	clk cycles
$t_{WUSLEEPFDSM}$		Flash memory in Deep power down mode	-	-	50.0	μs
t_{WUSTOP}	Wakeup from STOP mode Code execution on Flash	Main regulator	-	12.7	15.0	
		Main regulator, Flash memory in Deep power down mode	-	104.1	120.0	
		Wakeup from Stop mode, regulator in low power mode ⁽²⁾	-	20.9	28.0	
		Regulator in low power mode, Flash memory in Deep power down mode ⁽²⁾	-	112.5	130.0	
		Regulator in low power mode low voltage, Flash memory in Deep power down mode	-	112.5	130.0	
t_{WUSTOP}	Wakeup from STOP mode code execution on RAM ⁽³⁾	Main regulator with Flash in Stop mode or Deep power down ⁽²⁾	-	4.2	7.0	
		Wakeup from Stop mode, regulator in low power mode and Flash in Stop mode or Deep power down	-	12.6	20.0	
$t_{WUSTDBY}$	Wakeup from Standby mode	-	-	328.2	400.0	μs
$t_{WUFLASH}$	Wakeup of Flash	From Flash_Stop mode	-	-	11.0	
		From Flash Deep power down mode	-	-	40.0	

1. Guaranteed by characterization results.
2. The specification is valid for wakeup from regulator in low power mode or low power low voltage mode, since the timing difference is negligible.
3. For the faster wakeup time for code execution on RAM, the Flash must be in STOP or DeepPower Down mode (see reference manual RM0430).

6.3.8 External clock source characteristics

High-speed external user clock generated from an external source

In bypass mode the HSE oscillator is switched off and the input pin is a standard I/O. The external clock signal has to respect the [Table 59](#). However, the recommended clock input waveform is shown in [Figure 27](#).

The characteristics given in [Table 41](#) result from tests performed using an high-speed external clock source, and under ambient temperature and supply voltage conditions

summarized in [Table 17](#).

Table 41. High-speed external user clock characteristics

Symbol	Parameter	Conditions	Min	Typ	Max	Unit
f_{HSE_ext}	External user clock source frequency ⁽¹⁾		1	-	50	MHz
V_{HSEH}	OSC_IN input pin high level voltage		$0.7V_{DD}$	-	V_{DD}	V
V_{HSEL}	OSC_IN input pin low level voltage		V_{SS}	-	$0.3V_{DD}$	
$t_{w(HSE)}$ $t_{w(HSE)}$	OSC_IN high or low time ⁽¹⁾		5	-	-	ns
$t_{r(HSE)}$ $t_{f(HSE)}$	OSC_IN rise or fall time ⁽¹⁾		-	-	10	
$C_{in(HSE)}$	OSC_IN input capacitance ⁽¹⁾		-	5	-	pF
$DuCy_{(HSE)}$	Duty cycle		45	-	55	%
I_L	OSC_IN Input leakage current	$V_{SS} \leq V_{IN} \leq V_{DD}$	-	-	± 1	μA

1. Guaranteed by design.

Low-speed external user clock generated from an external source

In bypass mode the LSE oscillator is switched off and the input pin is a standard I/O. The external clock signal has to respect the [Table 59](#). However, the recommended clock input waveform is shown in [Figure 28](#).

The characteristics given in [Table 42](#) result from tests performed using an low-speed external clock source, and under ambient temperature and supply voltage conditions summarized in [Table 17](#).

Table 42. Low-speed external user clock characteristics

Symbol	Parameter	Conditions	Min	Typ	Max	Unit
f_{LSE_ext}	User External clock source frequency ⁽¹⁾		-	32.768	1000	kHz
V_{LSEH}	OSC32_IN input pin high level voltage		$0.7V_{DD}$	-	V_{DD}	
V_{LSEL}	OSC32_IN input pin low level voltage		V_{SS}	-	$0.3V_{DD}$	V
$t_{w(LSE)}$ $t_{f(LSE)}$	OSC32_IN high or low time ⁽¹⁾		450	-	-	
$t_{r(LSE)}$ $t_{f(LSE)}$	OSC32_IN rise or fall time ⁽¹⁾		-	-	50	ns
$C_{in(LSE)}$	OSC32_IN input capacitance ⁽¹⁾		-	5	-	
$DuCy_{(LSE)}$	Duty cycle		30	-	70	%
I_L	OSC32_IN Input leakage current	$V_{SS} \leq V_{IN} \leq V_{DD}$	-	-	± 1	μA

1. Guaranteed by design.

Figure 27. High-speed external clock source AC timing diagram

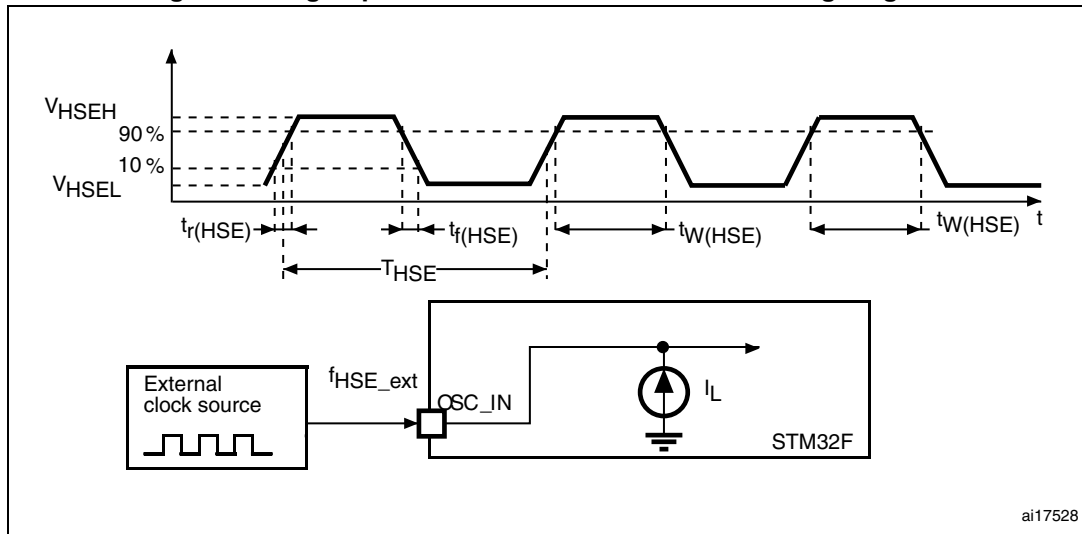

ai17528

Figure 28. Low-speed external clock source AC timing diagram

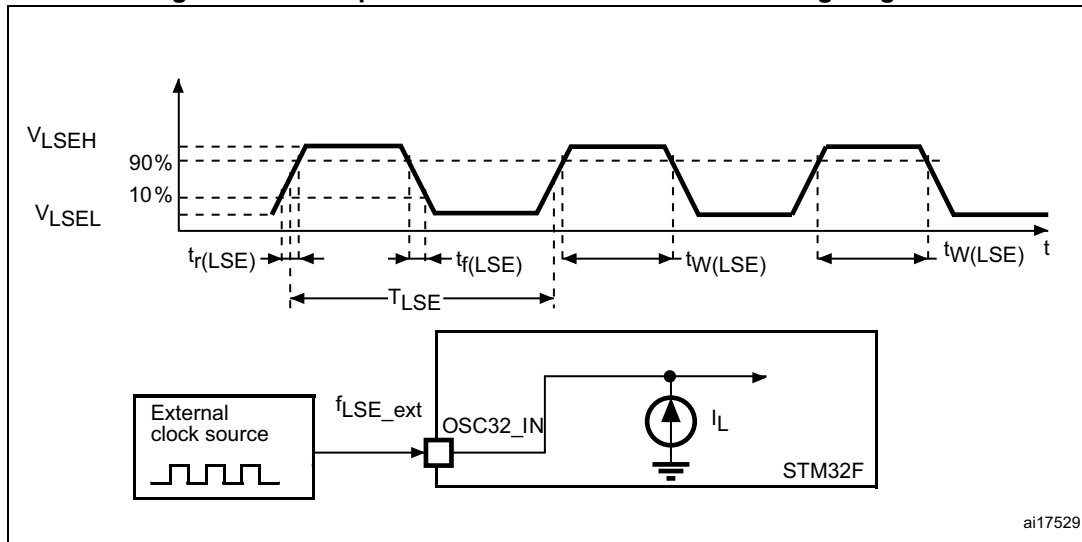

ai17529

High-speed external clock generated from a crystal/ceramic resonator

The high-speed external (HSE) clock can be supplied with a 4 to 26 MHz crystal/ceramic resonator oscillator. All the information given in this paragraph are based on characterization results obtained with typical external components specified in [Table 43](#). In the application, the resonator and the load capacitors have to be placed as close as possible to the oscillator pins in order to minimize output distortion and startup stabilization time. Refer to the crystal resonator manufacturer for more details on the resonator characteristics (frequency, package, accuracy).

Table 43. HSE 4-26 MHz oscillator characteristics⁽¹⁾

Symbol	Parameter	Conditions	Min	Typ	Max	Unit
f_{OSC_IN}	Oscillator frequency		4	-	26	MHz
R_F	Feedback resistor		-	200	-	k Ω
I_{DD}	HSE current consumption	$V_{DD}=3.3\text{ V}$, ESR= 30 Ω $C_L=5\text{ pF @}25\text{ MHz}$	-	450	-	μA
		$V_{DD}=3.3\text{ V}$, ESR= 30 Ω $C_L=10\text{ pF @}25\text{ MHz}$	-	530	-	
$ACC_{HSE}^{(2)}$	HSE accuracy	-	-500	-	500	ppm
$G_{m_crit_max}$	Maximum critical crystal g_m	Startup	-	-	1	mA/V
$t_{SU(HSE)}^{(3)}$	Startup time	V_{DD} is stabilized	-	2	-	ms

1. Guaranteed by design.
2. This parameter depends on the crystal used in the application. The minimum and maximum values must be respected to comply with USB standard specifications.
3. $t_{SU(HSE)}$ is the startup time measured from the moment it is enabled (by software) to a stabilized 8 MHz oscillation is reached. This value is measured for a standard crystal resonator and it can vary significantly with the crystal manufacturer

For C_{L1} and C_{L2} , it is recommended to use high-quality external ceramic capacitors in the 5 pF to 25 pF range (Typ.), designed for high-frequency applications, and selected to match the requirements of the crystal or resonator (see [Figure 29](#)). C_{L1} and C_{L2} are usually the same size. The crystal manufacturer typically specifies a load capacitance which is the series combination of C_{L1} and C_{L2} . PCB and MCU pin capacitance must be included (10 pF can be used as a rough estimate of the combined pin and board capacitance) when sizing C_{L1} and C_{L2} .

Note: For information on selecting the crystal, refer to the application note AN2867 “Oscillator design guide for ST microcontrollers” available from the ST website www.st.com.

Figure 29. Typical application with an 8 MHz crystal

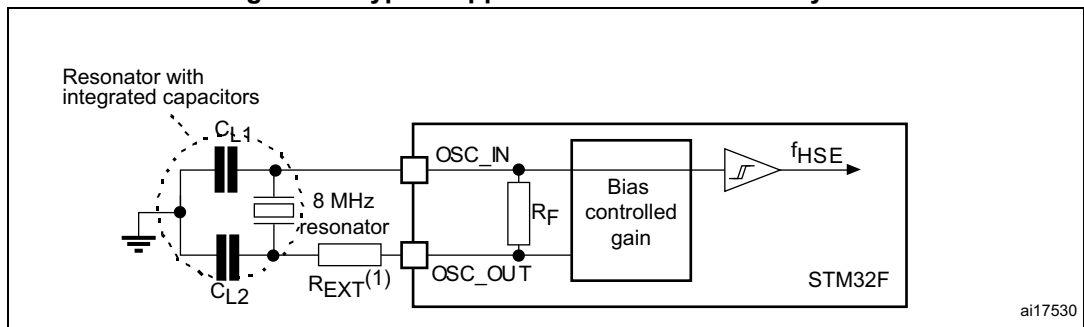

1. R_{EXT} value depends on the crystal characteristics.

Low-speed external clock generated from a crystal/ceramic resonator

The low-speed external (LSE) clock can be supplied with a 32.768 kHz crystal/ceramic resonator oscillator. All the information given in this paragraph are based on characterization results obtained with typical external components specified in [Table 44](#). In the application, the resonator and the load capacitors have to be placed as close as

possible to the oscillator pins in order to minimize output distortion and startup stabilization time. Refer to the crystal resonator manufacturer for more details on the resonator characteristics (frequency, package, accuracy).

The LSE high-power mode allows to cover a wider range of possible crystals but with a cost of higher power consumption.

Table 44. LSE oscillator characteristics ($f_{LSE} = 32.768 \text{ kHz}$) ⁽¹⁾

Symbol	Parameter	Conditions	Min	Typ	Max	Unit
R_F	Feedback resistor	-	-	18.4	-	$M\Omega$
I_{DD}	LSE current consumption	Low-power mode (default)	-	-	1	μA
		High-drive mode	-	-	3	
$ACC_{LSE}^{(2)}$	LSE accuracy	-	-500	-	500	ppm
$G_{m_crit_max}$	Maximum critical crystal g_m	Startup, low-power mode	-	-	0.56	$\mu A/V$
		Startup, high-drive mode	-	-	1.50	
$t_{SU(LSE)}^{(3)}$	startup time	V_{DD} is stabilized	-	2	-	s

1. Guaranteed by design.
2. This parameter depends on the crystal used in the application. Refer to the application note AN2867.
3. $t_{SU(LSE)}$ is the startup time measured from the moment it is enabled (by software) to a stabilized 32.768 kHz oscillation is reached. This value is guaranteed by characterization and not tested in production. It is measured for a standard crystal resonator and it can vary significantly with the crystal manufacturer.

Note: For information on selecting the crystal, refer to the application note AN2867 "Oscillator design guide for ST microcontrollers" available from the ST website www.st.com.
For information about the LSE high-power mode, refer to the reference manual RM0383.

Figure 30. Typical application with a 32.768 kHz crystal

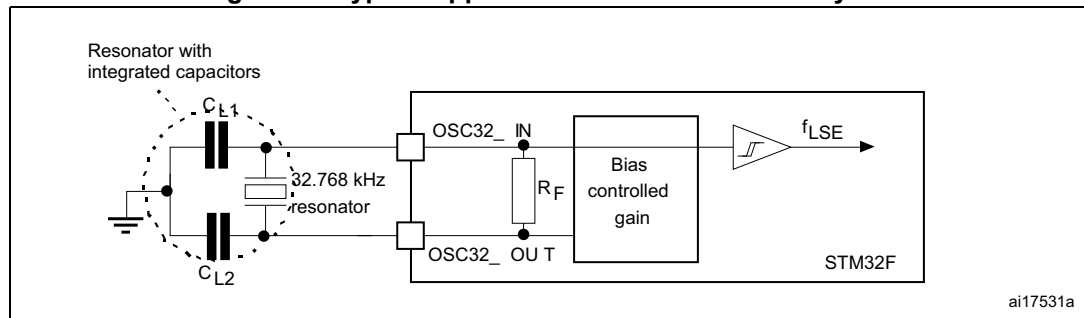

6.3.9 Internal clock source characteristics

The parameters given in [Table 45](#) and [Table 46](#) are derived from tests performed under ambient temperature and V_{DD} supply voltage conditions summarized in [Table 17](#).

High-speed internal (HSI) RC oscillator

Table 45. HSI oscillator characteristics (1)

Symbol	Parameter	Conditions	Min	Typ	Max	Unit
f_{HSI}	Frequency	-	-	16	-	MHz
ACC_{HSI}	Accuracy of the HSI oscillator	$T_A = -40$ to 125 °C ⁽³⁾	-8	-	6.75	%
		$T_A = -40$ to 105 °C ⁽³⁾	-8	-	4.5	%
		$T_A = -10$ to 85 °C ⁽³⁾	-4	-	4	%
		$T_A = 25$ °C ⁽⁴⁾	-1	-	1	%
$t_{su(HSI)}$ ⁽²⁾	HSI oscillator startup time	-	-	2.2	4	μs
$I_{DD(HSI)}$ ⁽²⁾	HSI oscillator power consumption	-	-	60	80	μA

- $V_{DD} = 3.3$ V, $T_A = -40$ to 125 °C unless otherwise specified.
- Guaranteed by design
- Based on characterization
- Factory calibrated, parts not soldered.

Figure 31. ACC_{HSI} versus temperature



- Guaranteed by characterization results.

Low-speed internal (LSI) RC oscillator

Table 46. LSI oscillator characteristics ⁽¹⁾

Symbol	Parameter	Min	Typ	Max	Unit
$f_{LSI}^{(2)}$	Frequency	16.1	32.0	47.0	kHz
$t_{su(LSI)}^{(3)}$	LSI oscillator startup time	-	15.0	40.0	μs
$I_{DD(LSI)}^{(3)}$	LSI oscillator power consumption	-	0.4	0.6	μA

1. $V_{DD} = 3 V$, $T_A = -40$ to $125\text{ }^\circ C$ unless otherwise specified.
2. Guaranteed by characterization results.
3. Guaranteed by design.

Figure 32. ACC_{LSI} versus temperature

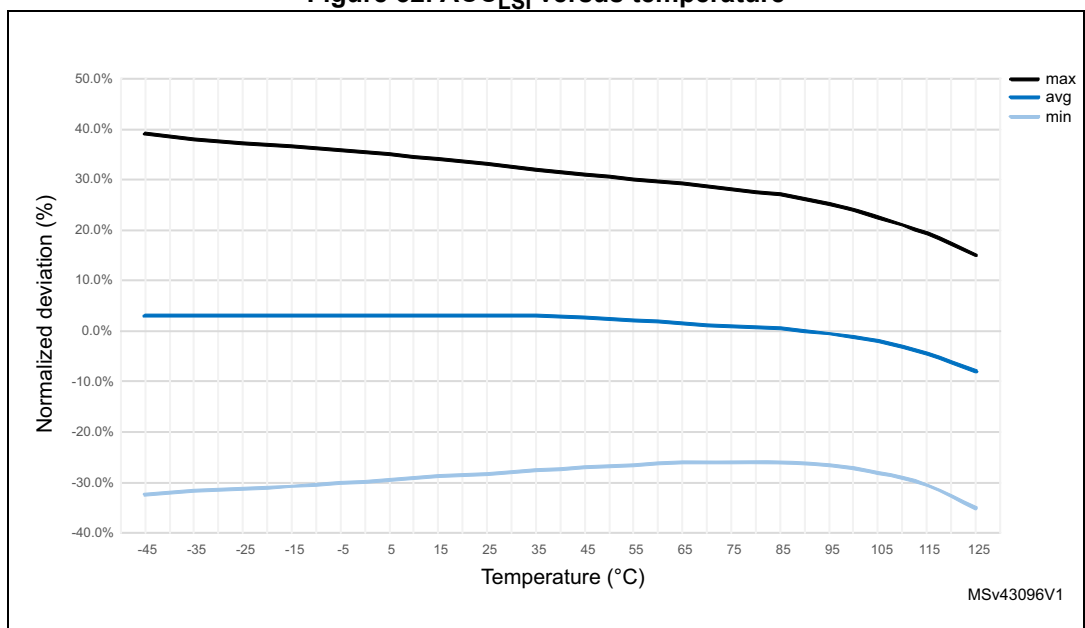

6.3.10 PLL characteristics

The parameters given in [Table 47](#) and [Table 48](#) are derived from tests performed under temperature and V_{DD} supply voltage conditions summarized in [Table 17](#).

Table 47. Main PLL characteristics

Symbol	Parameter	Conditions	Min	Typ	Max	Unit	
f _{PLL_IN}	PLL input clock ⁽¹⁾	-	0.95 ⁽²⁾	1	2.10	MHz	
f _{PLL_OUT}	PLL multiplier output clock	-	24	-	100		
f _{PLLQ_OUT}	48 MHz PLLQ multiplier output clock	-	-	48	75		
f _{PLLR_OUT}	PLLR multiplier output clock for I2S and SAI	-	-	-	216		
f _{VCO_OUT}	PLL VCO output	-	100	-	432		
t _{LOCK}	PLL lock time	VCO freq = 100 MHz	75	-	200	µs	
		VCO freq = 432 MHz	100	-	300		
Jitter ⁽³⁾	Cycle-to-cycle jitter	System clock 100 MHz	RMS	-	25	-	ps
			peak to peak	-	±150	-	
	Period Jitter		RMS	-	15	-	
			peak to peak	-	±200	-	
	Bit Time CAN jitter	Cycle to cycle at 1 MHz on 1000 samples.	-	330	-		
I _{DD(PLL)} ⁽⁴⁾	PLL power consumption on VDD	VCO freq = 100 MHz	0.15	-	0.40	mA	
		VCO freq = 432 MHz	0.45	-	0.75		
I _{DDA(PLL)} ⁽⁴⁾	PLL power consumption on VDDA	VCO freq = 100 MHz	0.30	-	0.40	mA	
		VCO freq = 432 MHz	0.55	-	0.85		

1. Take care of using the appropriate division factor M to obtain the specified PLL input clock values. The M factor is shared between PLL and PLLI2S.
2. Guaranteed by design.
3. The use of two PLLs in parallel could degraded the Jitter up to +30%.
4. Guaranteed by characterization results.

Table 48. PLLI2S (audio PLL) characteristics

Symbol	Parameter	Conditions	Min	Typ	Max	Unit
f_{PLL_IN}	PLL input clock ⁽¹⁾	-	0.95 ⁽²⁾	1	2.10	MHz
f_{PLL2SQ_OUT}	48 MHz PLLI2SQ multiplier output clock	-	-	48	75	
f_{PLL2SR_OUT}	PLLI2SR multiplier output clock for I2S and SAI	-	-	-	216	
f_{VCO_OUT}	PLLI2S VCO output	-	100	-	432	
t_{LOCK}	PLLI2S lock time	VCO freq = 100 MHz	75	-	200	µs
		VCO freq = 432 MHz	100	-	300	
Jitter ⁽³⁾	Master I2S clock jitter	Cycle to cycle at 12.288 MHz on 48 kHz period, N=432, R=5	RMS	-	90	ps
			peak to peak	-	±280	
	Average frequency of 12.288 MHz N = 432, R = 5 on 1000 samples	-	90	-		
	WS I2S clock jitter	Cycle to cycle at 48 KHz on 1000 samples	-	400	-	
$I_{DD(PLLI2S)}^{(4)}$	PLLI2S power consumption on V_{DD}	VCO freq = 100 MHz	0.15	-	0.40	mA
		VCO freq = 432 MHz	0.45	-	0.75	
$I_{DDA(PLLI2S)}^{(4)}$	PLLI2S power consumption on V_{DDA}	VCO freq = 100 MHz VCO freq = 432 MHz	0.30 0.55	-	0.40 0.85	

1. Take care of using the appropriate division factor M to have the specified PLL input clock values.
2. Guaranteed by design.
3. Value given with main PLL running.
4. Guaranteed by characterization results.

6.3.11 PLL spread spectrum clock generation (SSCG) characteristics

The spread spectrum clock generation (SSCG) feature allows to reduce electromagnetic interferences (see [Table 55: EMI characteristics for LQFP144](#)). It is available only on the main PLL.

Table 49. SSCG parameter constraints

Symbol	Parameter	Min	Typ	Max ⁽¹⁾	Unit
f_{Mod}	Modulation frequency	-	-	10	kHz
md	Peak modulation depth	0.25	-	2	%
MODEPER * INCSTEP	(Modulation period) * (Increment Step)	-	-	$2^{15}-1$	-

1. Guaranteed by design.

Equation 1

The frequency modulation period (MODEPER) is given by the equation below:

$$MODEPER = \text{round}[f_{PLL_IN} / (4 \times f_{Mod})]$$

f_{PLL_IN} and f_{Mod} must be expressed in Hz.

As an example:

If $f_{PLL_IN} = 1$ MHz, and $f_{MOD} = 1$ kHz, the modulation depth (MODEPER) is given by equation 1:

$$MODEPER = \text{round}[10^6 / (4 \times 10^3)] = 250$$

Equation 2

Equation 2 allows to calculate the increment step (INCSTEP):

$$INCSTEP = \text{round}[(2^{15} - 1) \times md \times PLLN] / (100 \times 5 \times MODEPER)$$

f_{VCO_OUT} must be expressed in MHz.

With a modulation depth (md) = ± 2 % (4 % peak to peak), and PLLN = 240 (in MHz):

$$INCSTEP = \text{round}[(2^{15} - 1) \times 2 \times 240] / (100 \times 5 \times 250) = 126md(\text{quantitized})\%$$

An amplitude quantization error may be generated because the linear modulation profile is obtained by taking the quantized values (rounded to the nearest integer) of MODPER and INCSTEP. As a result, the achieved modulation depth is quantized. The percentage quantized modulation depth is given by the following formula:

$$md_{\text{quantitized}}\% = (MODEPER \times INCSTEP \times 100 \times 5) / ((2^{15} - 1) \times PLLN)$$

As a result:

$$md_{\text{quantitized}}\% = (250 \times 126 \times 100 \times 5) / ((2^{15} - 1) \times 240) = 2.002\%(\text{peak})$$

Figure 33 and Figure 34 show the main PLL output clock waveforms in center spread and down spread modes, where:

- F0 is f_{PLL_OUT} nominal.
- T_{mode} is the modulation period.
- md is the modulation depth.

Figure 33. PLL output clock waveforms in center spread mode

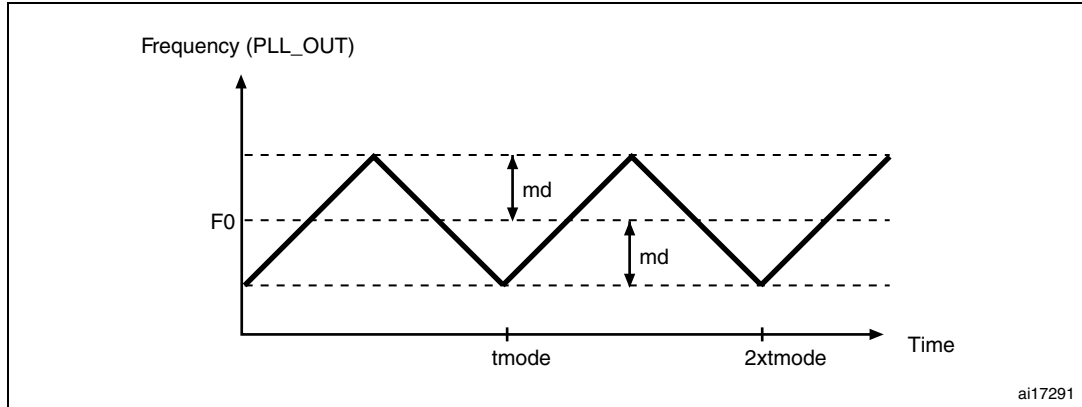
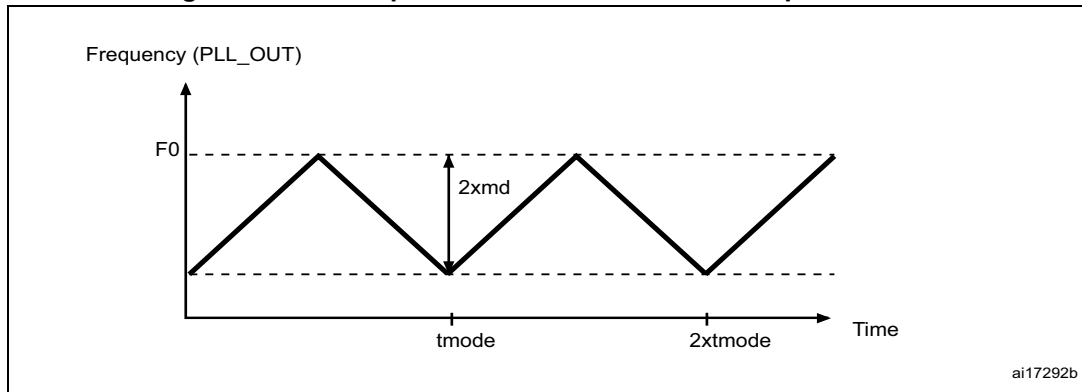

Figure 34. PLL output clock waveforms in down spread mode



6.3.12 Memory characteristics

Flash memory

The characteristics are given at $T_A = -40$ to 125 °C unless otherwise specified.

The devices are shipped to customers with the Flash memory erased.

Table 50. Flash memory characteristics

Symbol	Parameter	Conditions	Min	Typ	Max	Unit
I_{DD}	Supply current	Write / Erase 8-bit mode, $V_{DD} = 1.7$ V	-	5	-	mA
		Write / Erase 16-bit mode, $V_{DD} = 2.1$ V	-	8	-	
		Write / Erase 32-bit mode, $V_{DD} = 3.3$ V	-	12	-	

Table 51. Flash memory programming

Symbol	Parameter	Conditions	Min ⁽¹⁾	Typ	Max ⁽¹⁾	Unit
t_{prog}	Word programming time	Program/erase parallelism (PSIZE) = x 8/16/32	-	16	100 ⁽²⁾	μ s
$t_{ERASE16KB}$	Sector (16 KB) erase time	Program/erase parallelism (PSIZE) = x 8	-	400	800	ms
		Program/erase parallelism (PSIZE) = x 16	-	300	600	
		Program/erase parallelism (PSIZE) = x 32	-	250	500	
$t_{ERASE64KB}$	Sector (64 KB) erase time	Program/erase parallelism (PSIZE) = x 8	-	1200	2400	ms
		Program/erase parallelism (PSIZE) = x 16	-	700	1400	
		Program/erase parallelism (PSIZE) = x 32	-	550	1100	
$t_{ERASE128KB}$	Sector (128 KB) erase time	Program/erase parallelism (PSIZE) = x 8	-	2	4	s
		Program/erase parallelism (PSIZE) = x 16	-	1.3	2.6	
		Program/erase parallelism (PSIZE) = x 32	-	1	2	
t_{ME}	Mass erase time	Program/erase parallelism (PSIZE) = x 8	-	24	48	s
		Program/erase parallelism (PSIZE) = x 16	-	15	30	
		Program/erase parallelism (PSIZE) = x 32	-	11	22	
V_{prog}	Programming voltage	32-bit program operation	2.7	-	3.6	V
		16-bit program operation	2.1	-	3.6	V
		8-bit program operation	1.7	-	3.6	V

1. Guaranteed by characterization results.

2. The maximum programming time is measured after 100K erase operations.

Table 52. Flash memory programming with V_{PP} voltage

Symbol	Parameter	Conditions	Min ⁽¹⁾	Typ	Max ⁽¹⁾	Unit
t _{prog}	Double word programming	T _A = 0 to +40 °C V _{DD} = 3.3 V V _{PP} = 8.5 V	-	16	100 ⁽²⁾	μs
t _{ERASE16KB}	Sector (16 KB) erase time		-	230	-	ms
t _{ERASE64KB}	Sector (64 KB) erase time		-	490	-	
t _{ERASE128KB}	Sector (128 KB) erase time		-	875	-	
t _{ME}	Mass erase time		-	9.8	-	s
V _{prog}	Programming voltage	-	2.7	-	3.6	V
V _{PP}	V _{PP} voltage range	-	7	-	9	V
I _{PP}	Minimum current sunk on the V _{PP} pin	-	10	-	-	mA
t _{VPP} ⁽³⁾	Cumulative time during which V _{PP} is applied	-	-	-	1	hour

1. Guaranteed by design.
2. The maximum programming time is measured after 100K erase operations.
3. V_{PP} should only be connected during programming/erasing.

Table 53. Flash memory endurance and data retention

Symbol	Parameter	Conditions	Value	Unit
			Min ⁽¹⁾	
N _{END}	Endurance	T _A = -40 to +85 °C (temp. range 6) T _A = -40 to +105 °C (temp. range 7) T _A = -40 to +125 °C (temp. range 3)	10	kcycles
t _{RET}	Data retention	1 kcycle ⁽²⁾ at T _A = 85 °C	30	Years
		1 kcycle ⁽²⁾ at T _A = 105 °C	10	
		1 kcycle ⁽²⁾ at T _A = 125 °C	3	
		10 kcycle ⁽²⁾ at T _A = 55 °C	20	

1. Guaranteed by characterization results.
2. Cycling performed over the whole temperature range.

6.3.13 EMC characteristics

Susceptibility tests are performed on a sample basis during device characterization.

Functional EMS (electromagnetic susceptibility)

While a simple application is executed on the device (toggling 2 LEDs through I/O ports), the device is stressed by two electromagnetic events until a failure occurs. The failure is indicated by the LEDs:

- **Electrostatic discharge (ESD)** (positive and negative) is applied to all device pins until a functional disturbance occurs. This test is compliant with the IEC 61000-4-2 standard.
- **FTB**: A burst of fast transient voltage (positive and negative) is applied to V_{DD} and V_{SS} through a 100 pF capacitor, until a functional disturbance occurs. This test is compliant with the IEC 61000-4-4 standard.

A device reset allows normal operations to be resumed.

The test results are given in [Table 55](#). They are based on the EMS levels and classes defined in application note AN1709.

Table 54. EMS characteristics for LQFP144 package

Symbol	Parameter	Conditions	Level/Class
V_{FESD}	Voltage limits to be applied on any I/O pin to induce a functional disturbance	$V_{DD} = 3.3\text{ V}$, LQFP144 $T_A = +25\text{ }^\circ\text{C}$, $f_{HCLK} = 100\text{ MHz}$, conforms to IEC 61000-4-2	1B
V_{EFTB}	Fast transient voltage burst limits to be applied through 100 pF on V_{DD} and V_{SS} pins to induce a functional disturbance	$V_{DD} = 3.3\text{ V}$, LQFP144 $T_A = +25\text{ }^\circ\text{C}$, $f_{HCLK} = 100\text{ MHz}$, conforms to IEC 61000-4-4	3B

When the application is exposed to a noisy environment, it is recommended to avoid pin exposition to disturbances. The pins showing a middle range robustness are: PA0, PA1, PA2, on LQFP144 packages and PDR_ON on WLCSP81.

As a consequence, it is recommended to add a serial resistor (1 kΩ maximum) located as close as possible to the MCU to the pins exposed to noise (connected to tracks longer than 50 mm on PCB).

Designing hardened software to avoid noise problems

EMC characterization and optimization are performed at component level with a typical application environment and simplified MCU software. It should be noted that good EMC performance is highly dependent on the user application and the software in particular.

Therefore it is recommended that the user applies EMC software optimization and prequalification tests in relation with the EMC level requested for his application.

Software recommendations

The software flowchart must include the management of runaway conditions such as:

- Corrupted program counter
- Unexpected reset
- Critical Data corruption (control registers...)

Prequalification trials

Most of the common failures (unexpected reset and program counter corruption) can be reproduced by manually forcing a low state on the NRST pin or the Oscillator pins for 1 second.

To complete these trials, ESD stress can be applied directly on the device, over the range of specification values. When unexpected behavior is detected, the software can be hardened to prevent unrecoverable errors occurring (see application note AN1015).

Electromagnetic Interference (EMI)

The electromagnetic field emitted by the device are monitored while a simple application, executing EEMBC code, is running. This emission test is compliant with IEC61967-2 standard which specifies the test board and the pin loading.

Table 55. EMI characteristics for LQFP144

Symbol	Parameter	Conditions	Monitored frequency band	Max vs. [f _{HSE} /f _{CPU}]	Unit
				8/100 MHz	
S _{EMI}	Peak level	V _{DD} = 3.6 V, T _A = 25 °C, LQFP144 package, conforming to IEC 61967-2, EEMBC, ART ON, all peripheral clocks enabled, clock dithering disabled.	0.1 to 30 MHz	13	dBµV
			30 to 130 MHz	21	
			130 MHz to 1 GHz	25	
			1 GHz to 2 GHz	19	
			EMI Level	4	-

6.3.14 Absolute maximum ratings (electrical sensitivity)

Based on three different tests (ESD, LU) using specific measurement methods, the device is stressed in order to determine its performance in terms of electrical sensitivity.

Electrostatic discharge (ESD)

Electrostatic discharges (a positive then a negative pulse separated by 1 second) are applied to the pins of each sample according to each pin combination. The sample size depends on the number of supply pins in the device (3 parts × (n+1) supply pins). This test conforms to the JESD22-A114/C101 standard.

Table 56. ESD absolute maximum ratings

Symbol	Ratings	Conditions	Class	Maximum value ⁽¹⁾	Unit
$V_{ESD(HBM)}$	Electrostatic discharge voltage (human body model)	$T_A = +25\text{ °C}$ conforming to JESD22-A114	2	2000	V
$V_{ESD(CDM)}$	Electrostatic discharge voltage (charge device model)	$T_A = +25\text{ °C}$ conforming to ANSI/ESD STM5.3.1, UFBGA144, UFBGA100, LQFP144, LQFP100, WLCSP81, LQFP64	3	250	
		$T_A = +25\text{ °C}$ conforming to ANSI/ESD STM5.3.1, UFQFPN48	4	500	

1. Guaranteed by characterization results.

Static latchup

Two complementary static tests are required on six parts to assess the latchup performance:

- A supply overvoltage is applied to each power supply pin
- A current injection is applied to each input, output and configurable I/O pin

These tests are compliant with EIA/JESD 78A IC latchup standard.

Table 57. Electrical sensitivities

Symbol	Parameter	Conditions	Class
LU	Static latch-up class	$T_A = +125\text{ °C}$ conforming to JESD78A	II level A

6.3.15 I/O current injection characteristics

As a general rule, current injection to the I/O pins, due to external voltage below V_{SS} or above V_{DD} (for standard, 3 V-capable I/O pins) should be avoided during normal product operation. However, in order to give an indication of the robustness of the microcontroller in cases when abnormal injection accidentally happens, susceptibility tests are performed on a sample basis during device characterization.

Functional susceptibility to I/O current injection

While a simple application is executed on the device, the device is stressed by injecting current into the I/O pins programmed in floating input mode. While current is injected into the I/O pin, one at a time, the device is checked for functional failures.

The failure is indicated by an out of range parameter: ADC error above a certain limit (>5 LSB TUE), out of conventional limits of induced leakage current on adjacent pins (out of $-5\text{ }\mu\text{A}/+0\text{ }\mu\text{A}$ range), or other functional failure (for example reset, oscillator frequency deviation).

Negative induced leakage current is caused by negative injection and positive induced leakage current by positive injection.

The test results are given in [Table 58](#).

Table 58. I/O current injection susceptibility⁽¹⁾

Symbol	Description	Functional susceptibility		Unit
		Negative injection	Positive injection	
I _{INJ}	Injected current on BOOT0, PDR_ON, BYPASS_REG	- 0	0	mA
	Injected current on NRST	- 0	NA	
	Injected current on PE6, PC13, PC14, PC15, PF0, PF1, PF2, PC0, PC1, PC2, PC3	- 0	NA	
	Injected current on any other FT and FTf pins	- 5	NA	
	Injected current on any other pins	- 5	+ 5	

1. NA = not applicable.

Note: It is recommended to add a Schottky diode (pin to ground) to analog pins which may potentially inject negative currents.

6.3.16 I/O port characteristics

General input/output characteristics

Unless otherwise specified, the parameters given in [Table 59](#) are derived from tests performed under the conditions summarized in [Table 17](#). All I/Os are CMOS and TTL compliant.

Table 59. I/O static characteristics

Symbol	Parameter	Conditions	Min	Typ	Max	Unit
V _{IL}	FT, TTa, TC and NRST I/O input low level voltage	1.7 V ≤ V _{DD} ≤ 3.6 V	-	-	0.3V _{DD} ⁽¹⁾	V
	BOOT0 I/O input low level voltage	1.75 V ≤ V _{DD} ≤ 3.6 V, -40 °C ≤ T _A ≤ 125 °C	-	-	0.1V _{DD} +0.1 ⁽²⁾	
		1.7 V ≤ V _{DD} ≤ 3.6 V, 0 °C ≤ T _A ≤ 125 °C	-	-		
V _{IH}	FT, TTa, TC and NRST I/O input high level voltage ⁽⁶⁾	1.7 V ≤ V _{DD} ≤ 3.6 V	0.7V _{DD} ⁽¹⁾	-	-	V
	BOOT0 I/O input high level voltage	1.75 V ≤ V _{DD} ≤ 3.6 V, -40 °C ≤ T _A ≤ 125 °C	0.17V _{DD} +0.7 ⁽²⁾	-	-	
		1.7 V ≤ V _{DD} ≤ 3.6 V, 0 °C ≤ T _A ≤ 125 °C		-	-	
V _{HYS} ⁽³⁾	FT, TTa, TC and NRST I/O input hysteresis	1.7 V ≤ V _{DD} ≤ 3.6 V	10% V _{DD} ⁽²⁾⁽⁴⁾	-	-	V
	BOOT0 I/O input hysteresis	1.75 V ≤ V _{DD} ≤ 3.6 V, -40 °C ≤ T _A ≤ 125 °C	0.1	-	-	
		1.7 V ≤ V _{DD} ≤ 3.6 V, 0 °C ≤ T _A ≤ 125 °C		-	-	

Table 59. I/O static characteristics (continued)

Symbol	Parameter		Conditions	Min	Typ	Max	Unit
I _{lkg}	I/O input leakage current ⁽⁵⁾		$V_{SS} \leq V_{IN} \leq V_{DD}$	-	-	±1	µA
	I/O FT/TC input leakage current ⁽⁶⁾		$V_{IN} = 5\text{ V}$	-	-	3	
R _{PU}	Weak pull-up equivalent resistor ⁽⁷⁾	All pins except for PA10 (OTG_FS_ID)	$V_{IN} = V_{SS}$	30	40	50	kΩ
		PA10 (OTG_FS_ID)	-	7	10	14	
R _{PD}	Weak pull-down equivalent resistor ⁽⁸⁾	All pins except for PA10 (OTG_FS_ID)	$V_{IN} = V_{DD}$	30	40	50	
		PA10 (OTG_FS_ID)	-	7	10	14	
C _{IO}	I/O pin capacitance		-	-	5	-	pF

1. Guaranteed by test in production.
2. Guaranteed by design.
3. Hysteresis voltage between Schmitt trigger switching levels. Guaranteed by characterization results.
4. With a minimum of 200 mV.
5. Leakage could be higher than the maximum value, if negative current is injected on adjacent pins, Refer to [Table 58: I/O current injection susceptibility](#)
6. To sustain a voltage higher than VDD +0.3 V, the internal pull-up/pull-down resistors must be disabled. Leakage could be higher than the maximum value, if negative current is injected on adjacent pins. Refer to [Table 58: I/O current injection susceptibility](#)
7. Pull-up resistors are designed with a true resistance in series with a switchable PMOS. This PMOS contribution to the series resistance is minimum (~10% order).
8. Pull-down resistors are designed with a true resistance in series with a switchable NMOS. This NMOS contribution to the series resistance is minimum (~10% order).

All I/Os are CMOS and TTL compliant (no software configuration required). Their characteristics cover more than the strict CMOS-technology or TTL parameters. The coverage of these requirements for FT and TC I/Os is shown in [Figure 35](#).

Figure 35. FT/TC I/O input characteristics

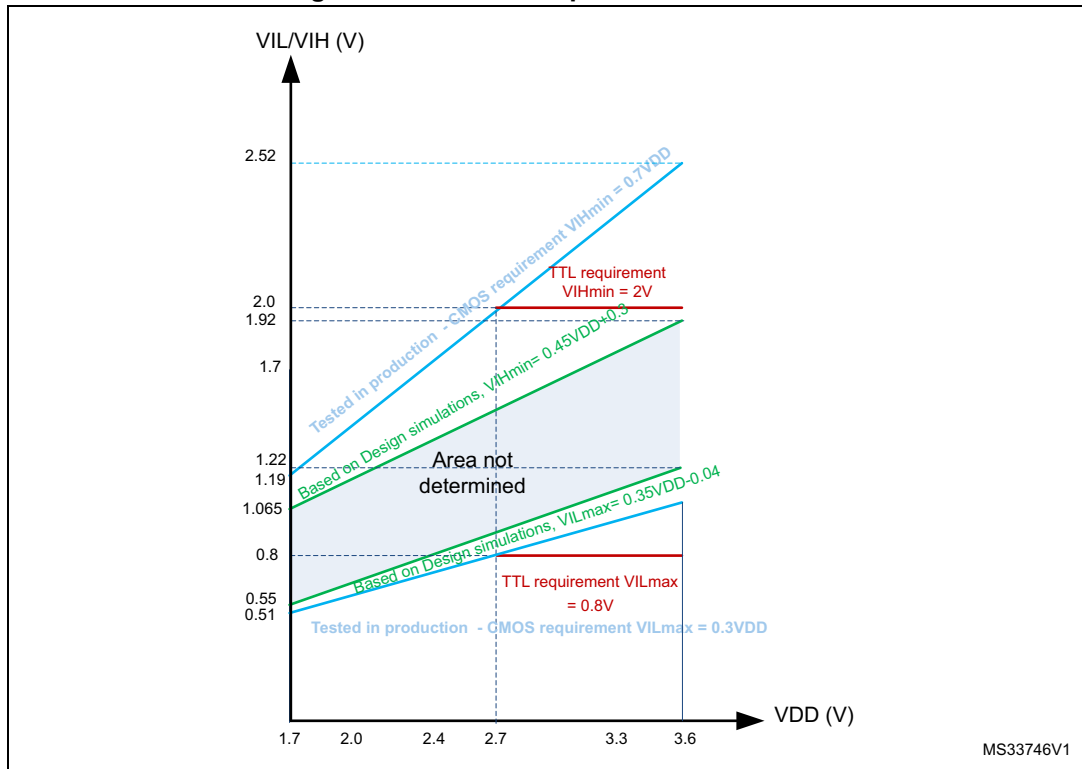

Output driving current

The GPIOs (general purpose input/outputs) can sink or source up to ± 8 mA, and sink or source up to ± 20 mA (with a relaxed V_{OL}/V_{OH}) except PC13, PC14 and PC15 which can sink or source up to ± 3 mA. When using the PC13 to PC15 GPIOs in output mode, the speed should not exceed 2 MHz with a maximum load of 30 pF.

In the user application, the number of I/O pins which can drive current must be limited to respect the absolute maximum rating specified in [Section 6.2](#). In particular:

- The sum of the currents sourced by all the I/Os on V_{DD} , plus the maximum Run consumption of the MCU sourced on V_{DD} , cannot exceed the absolute maximum rating ΣI_{VDD} (see [Table 15](#)).
- The sum of the currents sunk by all the I/Os on V_{SS} plus the maximum Run consumption of the MCU sunk on V_{SS} cannot exceed the absolute maximum rating ΣI_{VSS} (see [Table 15](#)).

Output voltage levels

Unless otherwise specified, the parameters given in [Table 60](#) are derived from tests performed under ambient temperature and V_{DD} supply voltage conditions summarized in [Table 17](#). All I/Os are CMOS and TTL compliant.

Table 60. Output voltage characteristics

Symbol	Parameter	Conditions	Min	Max	Unit
$V_{OL}^{(1)}$	Output low level voltage for an I/O pin	CMOS port ⁽²⁾ $I_{IO} = +8 \text{ mA}$ $2.7 \text{ V} \leq V_{DD} \leq 3.6 \text{ V}$	-	0.4	V
$V_{OH}^{(3)}$	Output high level voltage for an I/O pin		$V_{DD}-0.4$	-	
$V_{OL}^{(1)}$	Output low level voltage for an I/O pin	TTL port ⁽²⁾ $I_{IO} = +8 \text{ mA}$ $2.7 \text{ V} \leq V_{DD} \leq 3.6 \text{ V}$	-	0.4	V
$V_{OH}^{(3)}$	Output high level voltage for an I/O pin		2.4	-	
$V_{OL}^{(1)}$	Output low level voltage for an I/O pin	$I_{IO} = +20 \text{ mA}$ $2.7 \text{ V} \leq V_{DD} \leq 3.6 \text{ V}$	-	1.3 ⁽⁴⁾	V
$V_{OH}^{(3)}$	Output high level voltage for an I/O pin		$V_{DD}-1.3^{(4)}$	-	
$V_{OL}^{(1)}$	Output low level voltage for an I/O pin	$I_{IO} = +6 \text{ mA}$ $1.8 \text{ V} \leq V_{DD} \leq 3.6 \text{ V}$	-	0.4 ⁽⁴⁾	V
$V_{OH}^{(3)}$	Output high level voltage for an I/O pin		$V_{DD}-0.4^{(4)}$	-	
$V_{OL}^{(1)}$	Output low level voltage for an I/O pin	$I_{IO} = +4 \text{ mA}$ $1.7 \text{ V} \leq V_{DD} \leq 3.6 \text{ V}$	-	0.4 ⁽⁵⁾	V
$V_{OH}^{(3)}$	Output high level voltage for an I/O pin		$V_{DD}-0.4^{(5)}$	-	
$V_{OLFM}^{(1)}$	Output low level voltage for an FTf I/O pin in FM+ mode	$I_{IO} = +20 \text{ mA}$ $2.7 \text{ V} \leq V_{DD} \leq 3.6 \text{ V}$	-	0.4	V
$V_{OLFM}^{(1)}$	Output low level voltage for an FTf I/O pin in FM+ mode	$I_{IO} = +10 \text{ mA}$ $1.8 \text{ V} \leq V_{DD} \leq 3.6 \text{ V}$	-	0.4	V

1. The I_{IO} current sunk by the device must always respect the absolute maximum rating specified in [Table 15](#), and the sum of I_{IO} (I/O ports and control pins) must not exceed I_{VSS} .
2. TTL and CMOS outputs are compatible with JEDEC standards JESD36 and JESD52.
3. The I_{IO} current sourced by the device must always respect the absolute maximum rating specified in [Table 15](#) and the sum of I_{IO} (I/O ports and control pins) must not exceed I_{VDD} .
4. Guaranteed by characterization results.
5. Guaranteed by design.

Input/output AC characteristics

The definition and values of input/output AC characteristics are given in [Figure 36](#) and [Table 61](#), respectively.

Unless otherwise specified, the parameters given in [Table 61](#) are derived from tests performed under the ambient temperature and V_{DD} supply voltage conditions summarized in [Table 17](#).

Table 61. I/O AC characteristics⁽¹⁾⁽²⁾

OSPEEDRy [1:0] bit value ⁽¹⁾	Symbol	Parameter	Conditions	Min	Typ	Max	Unit
00	f _{max(IO)out}	Maximum frequency ⁽³⁾	C _L = 50 pF, V _{DD} ≥ 2.70 V	-	-	4	MHz
			C _L = 50 pF, V _{DD} ≥ 1.7 V	-	-	2	
			C _L = 10 pF, V _{DD} ≥ 2.70 V	-	-	8	
			C _L = 10 pF, V _{DD} ≥ 1.7 V	-	-	4	
	t _{f(IO)out} / t _{r(IO)out}	Output high to low level fall time and output low to high level rise time	C _L = 50 pF, V _{DD} = 1.7 V to 3.6 V	-	-	100	ns
01	f _{max(IO)out}	Maximum frequency ⁽³⁾	C _L = 50 pF, V _{DD} ≥ 2.70 V	-	-	25	MHz
			C _L = 50 pF, V _{DD} ≥ 1.7 V	-	-	12.5	
			C _L = 10 pF, V _{DD} ≥ 2.70 V	-	-	50	
			C _L = 10 pF, V _{DD} ≥ 1.7 V	-	-	20	
	t _{f(IO)out} / t _{r(IO)out}	Output high to low level fall time and output low to high level rise time	C _L = 50 pF, V _{DD} ≥ 2.7 V	-	-	10	ns
			C _L = 50 pF, V _{DD} ≥ 1.7 V	-	-	20	
			C _L = 10 pF, V _{DD} ≥ 2.70 V	-	-	6	
			C _L = 10 pF, V _{DD} ≥ 1.7 V	-	-	10	
10	f _{max(IO)out}	Maximum frequency ⁽³⁾	C _L = 40 pF, V _{DD} ≥ 2.70 V	-	-	50 ⁽⁴⁾	MHz
			C _L = 40 pF, V _{DD} ≥ 1.7 V	-	-	25	
			C _L = 10 pF, V _{DD} ≥ 2.70 V	-	-	100 ⁽⁴⁾	
			C _L = 10 pF, V _{DD} ≥ 1.7 V	-	-	50 ⁽⁴⁾	
	t _{f(IO)out} / t _{r(IO)out}	Output high to low level fall time and output low to high level rise time	C _L = 40 pF, V _{DD} ≥ 2.70 V	-	-	6	ns
			C _L = 40 pF, V _{DD} ≥ 1.7 V	-	-	10	
			C _L = 10 pF, V _{DD} ≥ 2.70 V	-	-	4	
			C _L = 10 pF, V _{DD} ≥ 1.7 V	-	-	6	
11	F _{max(IO)out}	Maximum frequency ⁽³⁾	C _L = 30 pF, V _{DD} ≥ 2.70 V	-	-	100 ⁽⁴⁾	MHz
			C _L = 30 pF, V _{DD} ≥ 1.7 V	-	-	50 ⁽⁴⁾	
	t _{f(IO)out} / t _{r(IO)out}	Output high to low level fall time and output low to high level rise time	C _L = 30 pF, V _{DD} ≥ 2.70 V	-	-	4	ns
			C _L = 30 pF, V _{DD} ≥ 1.7 V	-	-	6	
FM+	F _{max}	Maximum frequency	C _L = 50 pF, 1.6 ≤ V _{DD} ≤ 3.6 V	-	-	1	MHz
	T _f	Output high to low level fall time		-	-	5	ns
-	t _{EXTIpw}	Pulse width of external signals detected by the EXTI controller	-	10	-	-	ns

1. Guaranteed by characterization results.
2. The I/O speed is configured using the OSPEEDRy[1:0] bits. Refer to the STM32F4xx reference manual for a description of the GPIOx_SPEEDR GPIO port output speed register.
3. The maximum frequency is defined in [Figure 36](#).
4. For maximum frequencies above 50 MHz and $V_{DD} > 2.4$ V, the compensation cell should be used.

Figure 36. I/O AC characteristics definition

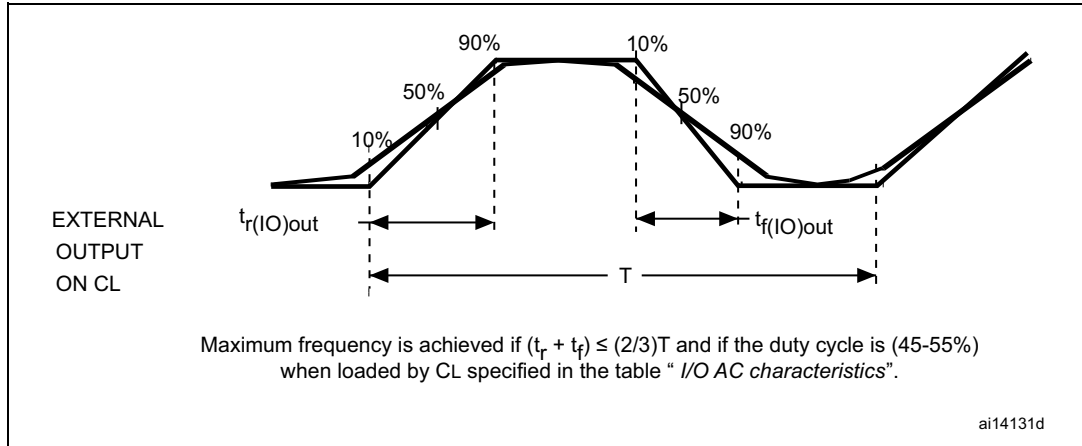

6.3.17 NRST pin characteristics

The NRST pin input driver uses CMOS technology. It is connected to a permanent pull-up resistor, R_{PU} (see [Table 59](#)).

Unless otherwise specified, the parameters given in [Table 62](#) are derived from tests performed under the ambient temperature and V_{DD} supply voltage conditions summarized in [Table 17](#). Refer to [Table 59: I/O static characteristics](#) for the values of V_{IH} and V_{IL} for NRST pin.

Table 62. NRST pin characteristics

Symbol	Parameter	Conditions	Min	Typ	Max	Unit
R_{PU}	Weak pull-up equivalent resistor ⁽¹⁾	$V_{IN} = V_{SS}$	30	40	50	k Ω
$V_{F(NRST)}^{(2)}$	NRST Input filtered pulse	-	-	-	100	ns
$V_{NF(NRST)}^{(2)}$	NRST Input not filtered pulse	$V_{DD} > 2.7$ V	300	-	-	ns
T_{NRST_OUT}	Generated reset pulse duration	Internal Reset source	20	-	-	μ s

1. The pull-up is designed with a true resistance in series with a switchable PMOS. This PMOS contribution to the series resistance must be minimum (~10% order).
2. Guaranteed by design.

Figure 37. Recommended NRST pin protection

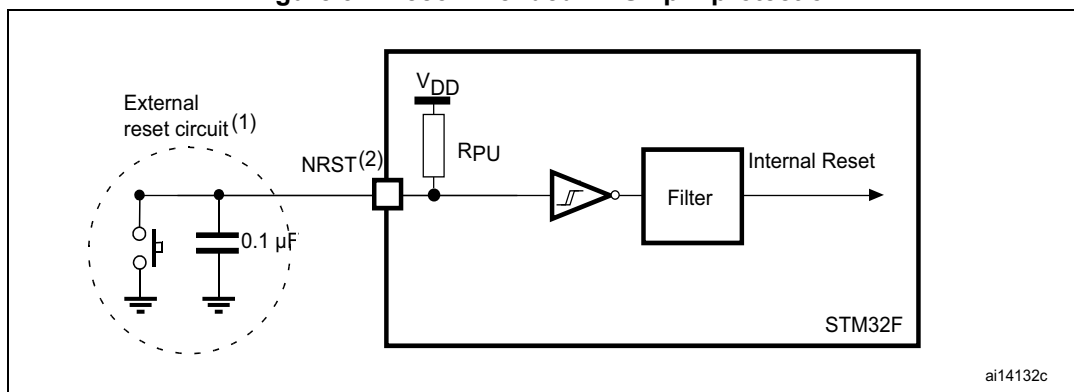

1. The reset network protects the device against parasitic resets.
2. The user must ensure that the level on the NRST pin can go below the $V_{IL(NRST)}$ max level specified in [Table 62](#). Otherwise the reset is not taken into account by the device.

6.3.18 TIM timer characteristics

The parameters given in [Table 63](#) are guaranteed by design.

Refer to [Section 6.3.16: I/O port characteristics](#) for details on the input/output alternate function characteristics (output compare, input capture, external clock, PWM output).

Table 63. TIMx characteristics⁽¹⁾⁽²⁾

Symbol	Parameter	Conditions ⁽³⁾	Min	Max	Unit
$t_{res(TIM)}$	Timer resolution time	AHB/APBx prescaler=1 or 2 or 4, $f_{TIMxCLK} = 100\text{ MHz}$	1	-	$t_{TIMxCLK}$
			11.9	-	ns
		AHB/APBx prescaler>4, $f_{TIMxCLK} = 100\text{ MHz}$	1	-	$t_{TIMxCLK}$
			11.9	-	ns
f_{EXT}	Timer external clock frequency on CH1 to CH4	$f_{TIMxCLK} = 100\text{ MHz}$	0	$f_{TIMxCLK}/2$	MHz
			0	50	MHz
Res_{TIM}	Timer resolution		-	16/32	bit
$t_{COUNTER}$	16-bit counter clock period when internal clock is selected	$f_{TIMxCLK} = 100\text{ MHz}$	0.0119	780	μs
t_{MAX_COUNT}	Maximum possible count with 32-bit counter	-	-	65536×65536	$t_{TIMxCLK}$
		$f_{TIMxCLK} = 100\text{ MHz}$	-	51.1	S

1. TIMx is used as a general term to refer to the TIM1 to TIM11 timers.
2. Guaranteed by design.
3. The maximum timer frequency on APB1 is 50 MHz and on APB2 is up to 100 MHz, by setting the TIMPRE bit in the RCC_DCKCFGR register, if APBx prescaler is 1 or 2 or 4, then $TIMxCLK = HCKL$, otherwise $TIMxCLK \geq 4 \times PCLKx$.

6.3.19 Communications interfaces

I²C interface characteristics

The I²C interface meets the requirements of the standard I²C communication protocol with the following restrictions: the I/O pins SDA and SCL are mapped to are not “true” open-drain. When configured as open-drain, the PMOS connected between the I/O pin and V_{DD} is disabled, but is still present.

The I²C characteristics are described in [Table 64](#). Refer also to [Section 6.3.16: I/O port characteristics](#) for more details on the input/output alternate function characteristics (SDA and SCL).

The I²C bus interface supports standard mode (up to 100 kHz) and fast mode (up to 400 kHz). The I²C bus frequency can be increased up to 1 MHz. For more details about the complete solution, contact your local ST sales representative.

Table 64. I²C characteristics

Symbol	Parameter	Standard mode I ² C ⁽¹⁾⁽²⁾		Fast mode I ² C ⁽¹⁾⁽²⁾		Unit
		Min	Max	Min	Max	
t _{w(SCLL)}	SCL clock low time	4.70	-	1.30	-	μs
t _{w(SCLH)}	SCL clock high time	4.0	-	0.60	-	
t _{su(SDA)}	SDA setup time	0.25	-	0.10	-	
t _{h(SDA)}	SDA data hold time	0	-	0	-	
t _{v(SDA,ACK)}	SDA data hold time	-	3.45 ⁽³⁾	-	0.90 ⁽⁴⁾	
t _{r(SDA)} t _{r(SCL)}	SDA and SCL rise time	-	0.100	-	0.30	
t _{f(SDA)} t _{f(SCL)}	SDA and SCL fall time	-	0.30	-	0.30	
t _{h(STA)}	Start condition hold time	4	-	0.6	-	
t _{su(STA)}	Repeated Start condition setup time	4.7	-	0.6	-	
t _{su(STO)}	Stop condition setup time	4	-	0.60	-	
t _{w(STO:STA)}	Stop to Start condition time (bus free)	4.70	-	1.3	-	
t _{SP}	Pulse width of the spikes that are suppressed by the analog filter for standard fast mode	-	-	0.05	0.10 ⁽⁵⁾	
C _b	Capacitive load for each bus line	-	400	-	400	pF

1. Guaranteed by design.
2. f_{CLK1} must be at least 2 MHz to achieve standard mode I²C frequencies. It must be at least 4 MHz to achieve fast mode I²C frequencies, and a multiple of 10 MHz to reach the 400 kHz maximum I²C fast mode clock.
3. The device must internally provide a hold time of at least 300 ns for the SDA signal in order to bridge the undefined region of the falling edge of SCL.
4. The maximum data hold time has only to be met if the interface does not stretch the low period of SCL signal.
5. The minimum width of the spikes filtered by the analog filter is above t_{SP} (max)

Figure 38. I²C bus AC waveforms and measurement circuit

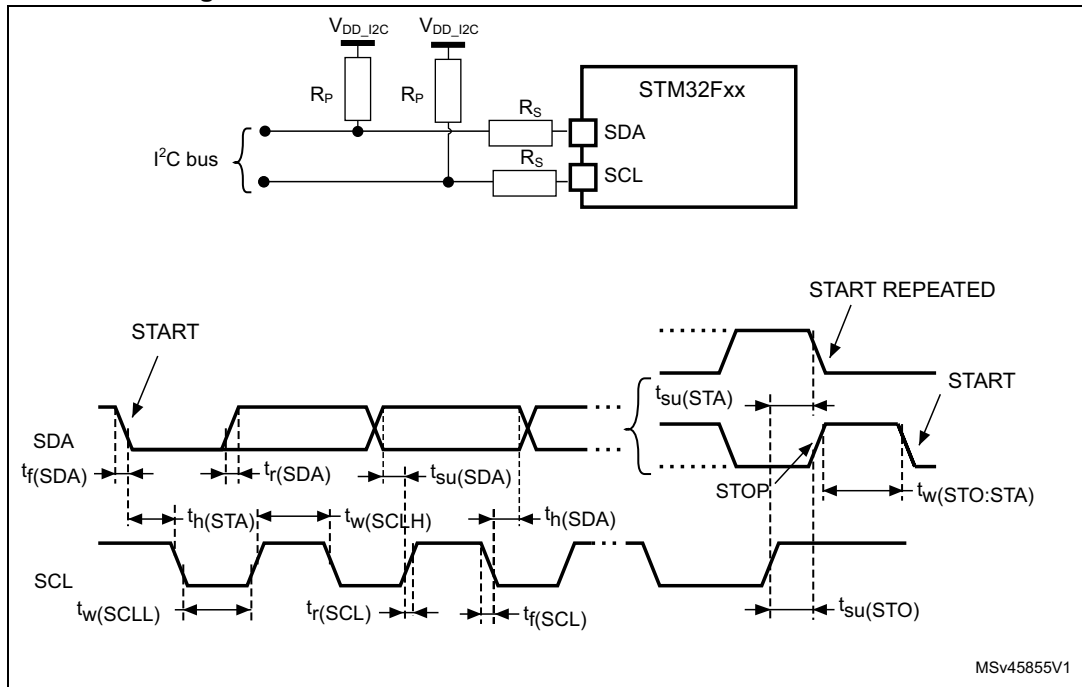

1. R_S = series protection resistor.
2. R_P = external pull-up resistor.
3. V_{DD_I2C} is the I2C bus power supply.

Table 65. SCL frequency ($f_{PCLK1} = 50 \text{ MHz}$, $V_{DD} = V_{DD_I2C} = 3.3 \text{ V}$)⁽¹⁾⁽²⁾

f_{SCL} (kHz)	I2C_CCR value
	$R_P = 4.7 \text{ k}\Omega$
400	0x8019
300	0x8021
200	0x8032
100	0x0096
50	0x012C
20	0x02EE

1. R_P = External pull-up resistance, $f_{SCL} = I^2C$ speed
2. For speeds around 200 kHz, the tolerance on the achieved speed is of $\pm 5\%$. For other speed ranges, the tolerance on the achieved speed is $\pm 2\%$. These variations depend on the accuracy of the external components used to design the application.

FMPI²C characteristics

The following table presents FMPI²C characteristics.

Refer also to [Section 6.3.16: I/O port characteristics](#) for more details on the input/output function characteristics (SDA and SCL).

Table 66. FMPI²C characteristics⁽¹⁾

	Parameter	Standard mode		Fast mode		Fast+ mode		Unit
		Min	Max	Min	Max	Min	Max	
f _{FMPI2CC}	FMPI2CCCLK frequency	2	-	8	-	18	-	μs
t _{w(SCLL)}	SCL clock low time	4.7	-	1.3	-	0.5	-	
t _{w(SCLH)}	SCL clock high time	4.0	-	0.6	-	0.26	-	
t _{su(SDA)}	SDA setup time	0.25	-	0.10	-	0.05	-	
t _{H(SDA)}	SDA data hold time	0	-	0	-	0	-	
t _{v(SDA,ACK)}	Data, ACK valid time	-	3.45	-	0.9	-	0.45	
t _{r(SDA)} t _{r(SCL)}	SDA and SCL rise time	-	1.0	-	0.30	-	0.12	
t _{f(SDA)} t _{f(SCL)}	SDA and SCL fall time	-	0.30	-	0.30	-0	0.12	
t _{H(STA)}	Start condition hold time	4	-	0.6	-	0.26	-	
t _{su(STA)}	Repeated Start condition setup time	4.7	-	0.6	-	0.26	-	
t _{su(STO)}	Stop condition setup time	4	-	0.6	-	0.26	-	
t _{w(STO:STA)}	Stop to Start condition time (bus free)	4.7	-	1.3	-	0.5	-	
t _{SPI}	Pulse width of the spikes that are suppressed by the analog filter for standard and fast mode	-	-	0.05	0.1	0.05	0.1	
C _b	Capacitive load for each bus Line	-	400	-	400	-	550 ⁽²⁾	pF

1. Based on characterization results.
2. Can be limited. Maximum supported value can be retrieved by referring to the following formulas:

$$t_{r(SDA/SCL)} = 0.8473 \times R_p \times C_{load}$$

$$R_{p(min)} = (V_{DD} - VOL_{(max)}) / IOL_{(max)}$$



Figure 39. FMPI²C timing diagram and measurement circuit

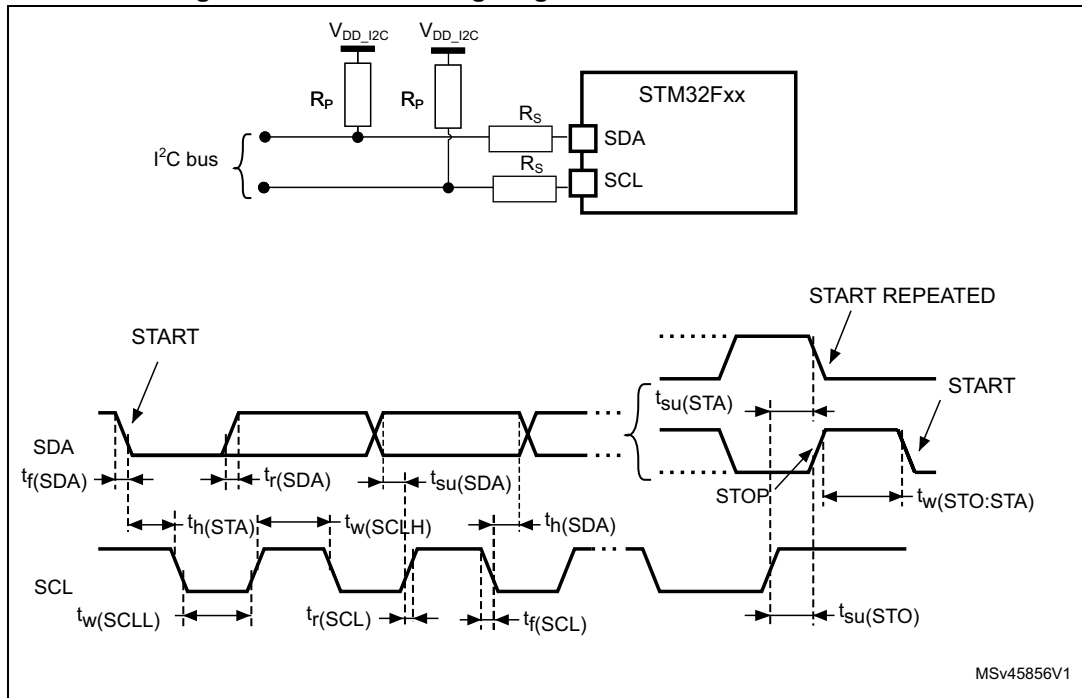

SPI interface characteristics

Unless otherwise specified, the parameters given in [Table 67](#) for the SPI interface are derived from tests performed under the ambient temperature, f_{PCLKx} frequency and V_{DD} supply voltage conditions summarized in [Table 17](#), with the following configuration:

- Output speed is set to $OSPEEDRy[1:0] = 10$
- Capacitive load $C = 30\text{ pF}$
- Measurement points are done at CMOS levels: $0.5V_{DD}$

Refer to [Section 6.3.16: I/O port characteristics](#) for more details on the input/output alternate function characteristics (NSS, SCK, MOSI, MISO for SPI).

Table 67. SPI dynamic characteristics⁽¹⁾

Symbol	Parameter	Conditions	Min	Typ	Max	Unit
f_{SCK} $1/t_{c(SCK)}$	SPI clock frequency	Master mode, SPI1,4,5 $3.0\text{ V} < V_{DD} < 3.6\text{ V}$	-	-	50	MHz
		Master mode, SPI1,4,5 $2.7\text{ V} < V_{DD} < 3.6\text{ V}$	-	-	42	
		Master mode SPI1,4,5 $1.7\text{ V} < V_{DD} < 3.6\text{ V}$	-	-	25	
		Master transmitter mode SPI1,4,5 $1.71\text{ V} < V_{DD} < 3.6\text{ V}$	-	-	50	
		Slave receiver mode SPI1,4,5 $1.71\text{ V} < V_{DD} < 3.6\text{ V}$	-	-	50	
		Slave mode transmitter/full duplex SPI1,4,5 $2.7\text{ V} < V_{DD} < 3.6\text{ V}$	-	-	40 ⁽²⁾	
		Slave mode transmitter/full duplex SPI1,4,5 $1.71\text{ V} < V_{DD} < 3.6\text{ V}$	-	-	26	
		Master & Slave mode, SPI2/3 $1.71\text{ V} < V_{DD} < 3.6\text{ V}$	-	-	25	
$t_{su(NSS)}$	NSS setup time	Slave mode, SPI presc = 2	$4 \cdot T_{PCLK}$	-	-	ns
$t_{h(NSS)}$	NSS hold time	Slave mode, SPI presc = 2	$2 \cdot T_{PCLK}$	-	-	ns
$t_{w(SCKH)}$ $t_{w(SCKL)}$	SCK high and low time	Master mode	$T_{PCLK} - 2$	T_{PCLK}	$T_{PCLK} + 2$	ns
$t_{su(MI)}$	Data input setup time	Master mode	2.5	-	-	ns
$t_{su(SI)}$		Slave mode	4.5	-	-	
$t_{h(MI)}$	Data input hold time	Master mode	5	-	-	ns
$t_{h(SI)}$		Slave mode	2	-	-	

Table 67. SPI dynamic characteristics⁽¹⁾ (continued)

Symbol	Parameter	Conditions	Min	Typ	Max	Unit
$t_{a(SO)}$	Data output access time	Slave mode	7	-	21	ns
$t_{dis(SO)}$	Data output disable time	Slave mode	5	-	12	ns
$t_{v(SO)}$	Data output valid time	Slave mode (after enable edge), 2.7 V < V_{DD} < 3.6 V	-	7	12.5	ns
		Slave mode (after enable edge), 1.71 V < V_{DD} < 3.6 V	-	7	19	
$t_{v(MO)}$		Master mode	-	2	3	
$t_{h(SO)}$	Data output hold time	Slave mode 1.71 V < V_{DD} < 3.6 V	6	-	-	ns
$t_{h(MO)}$		Master mode	1.5	-	-	

1. Guaranteed by characterization results.
2. Maximum frequency in Slave transmitter mode is determined by the sum of $t_{v(SO)}$ and $t_{su(MI)}$ which has to fit into SCK low or high phase preceding the SCK sampling edge. This value can be achieved when the SPI communicates with a master having $t_{su(MI)} = 0$ while Duty(SCK) = 50%

Figure 40. SPI timing diagram - slave mode and CPHA = 0

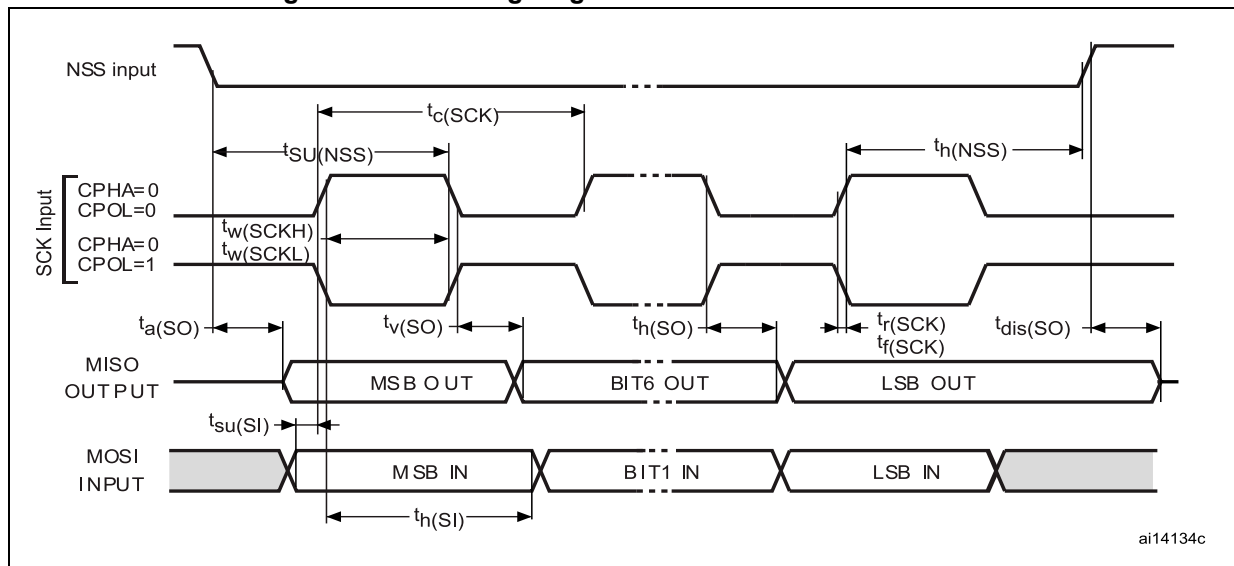

Figure 41. SPI timing diagram - slave mode and CPHA = 1

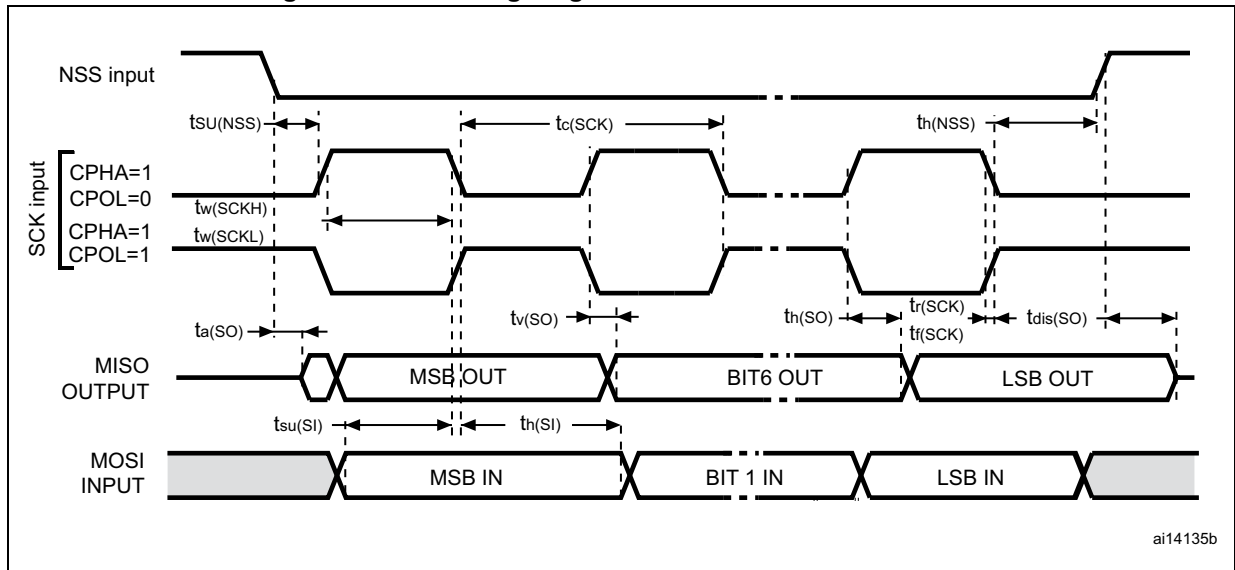
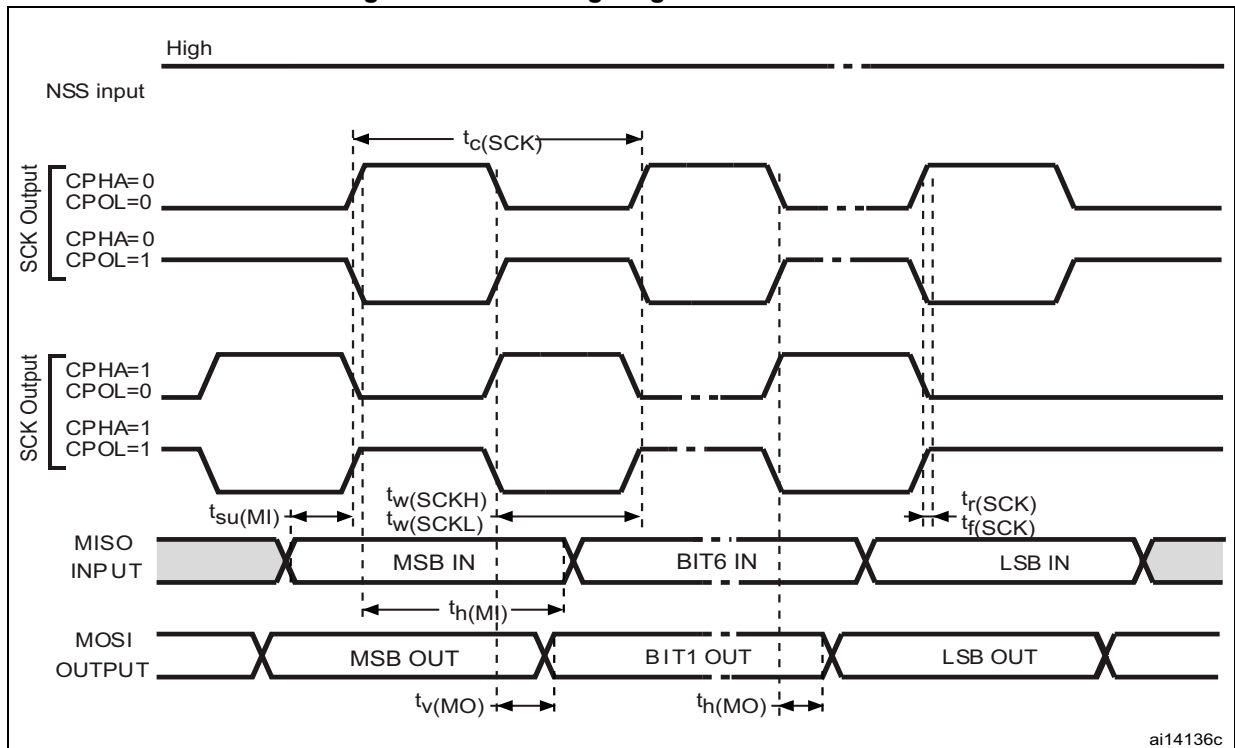

Figure 42. SPI timing diagram - master mode



I²S interface characteristics

Unless otherwise specified, the parameters given in [Table 68](#) for the I²S interface are derived from tests performed under the ambient temperature, f_{PCLKX} frequency and V_{DD} supply voltage conditions summarized in [Table 17](#), with the following configuration:

- Output speed is set to OSPEEDRy[1:0] = 10
- Capacitive load C = 30 pF
- Measurement points are done at CMOS levels: $0.5V_{DD}$

Refer to [Section 6.3.16: I/O port characteristics](#) for more details on the input/output alternate function characteristics (CK, SD, WS).

Table 68. I²S dynamic characteristics⁽¹⁾

Symbol	Parameter	Conditions	Min	Max	Unit
f_{MCK}	I2S Main clock output	-	256 * 8K	256 * F_S ⁽²⁾	MHz
f_{CK}	I2S clock frequency	Master data: 32 bits	-	64 * F_S	MHz
		Slave data: 32 bits	-	64 * F_S	
D_{CK}	I2S clock frequency duty cycle	Slave receiver	30	70	%
$t_{v(WS)}$	WS valid time	Master mode	-	3.5	ns
$t_{h(WS)}$	WS hold time	Master mode	1.5	-	
$t_{su(WS)}$	WS setup time	Slave mode	2.5	-	
$t_{h(WS)}$	WS hold time	Slave mode	0.5	-	
$t_{su(SD_MR)}$	Data input setup time	Master receiver	3	-	
$t_{su(SD_SR)}$		Slave receiver	2.5	-	
$t_{h(SD_MR)}$	Data input hold time	Master receiver	5	-	
$t_{h(SD_SR)}$		Slave receiver	1.5	-	
$t_{v(SD_ST)}$	Data output valid time	Slave transmitter (after enable edge)	-	15	
$t_{v(SD_MT)}$		Master transmitter (after enable edge)	-	6	
$t_{h(SD_ST)}$	Data output hold time	Slave transmitter (after enable edge)	3.5	-	
$t_{h(SD_MT)}$		Master transmitter (after enable edge)	1.5	-	

1. Guaranteed by characterization results.
2. The maximum value of 256x F_S is 50 MHz (APB1 maximum frequency).

Note: Refer to the I2S section of RM0430 reference manual for more details on the sampling frequency (F_S).

f_{MCK} , f_{CK} , and D_{CK} values reflect only the digital peripheral behavior. The values of these parameters might be slightly impacted by the source clock precision. D_{CK} depends mainly on the value of ODD bit. The digital contribution leads to a minimum value of $(I2SDIV/(2*I2SDIV+ODD))$ and a maximum value of $(I2SDIV+ODD)/(2*I2SDIV+ODD)$. F_S maximum value is supported for each mode/condition.

Figure 43. I²S slave timing diagram (Philips protocol)

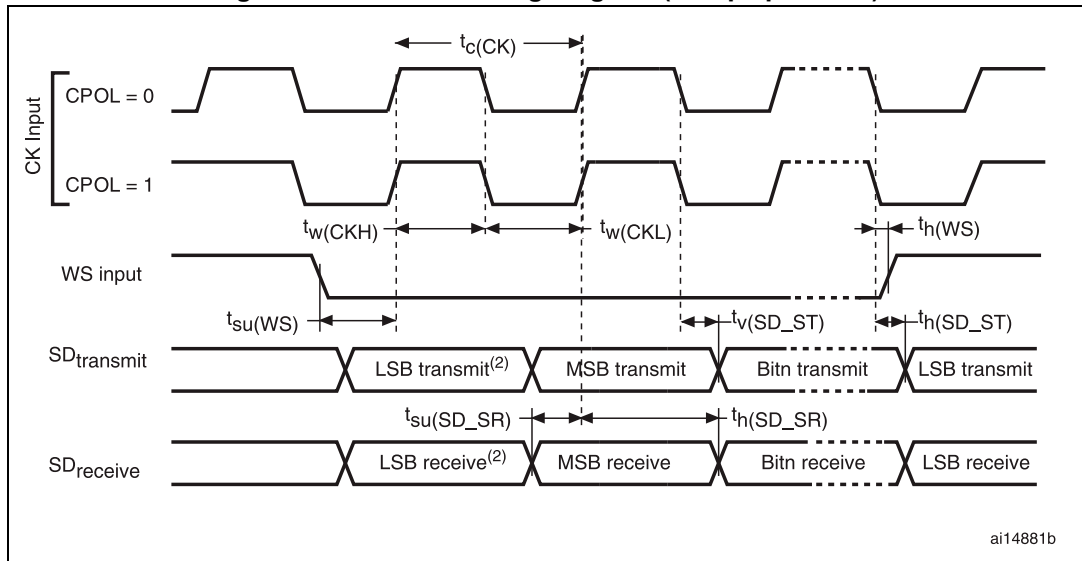

1. LSB transmit/receive of the previously transmitted byte. No LSB transmit/receive is sent before the first byte.

Figure 44. I²S master timing diagram (Philips protocol)

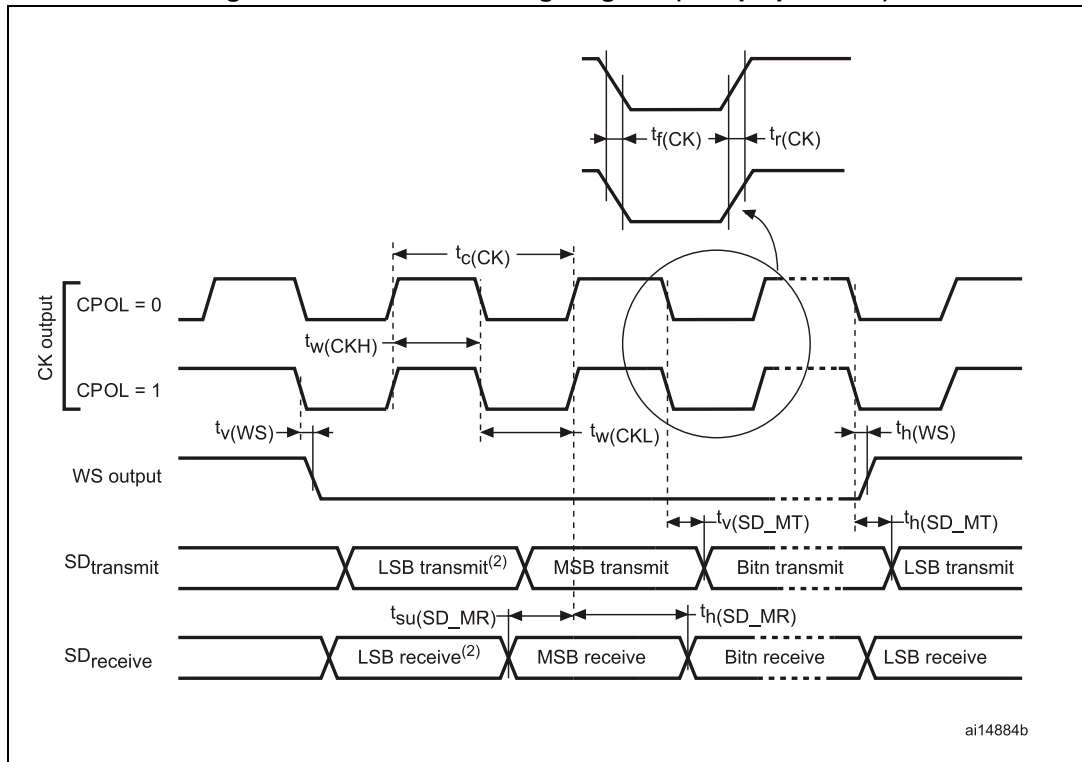

1. LSB transmit/receive of the previously transmitted byte. No LSB transmit/receive is sent before the first byte.

SAI characteristics

Unless otherwise specified, the parameters given in [Table 69](#) for SAI are derived from tests performed under the ambient temperature, f_{PCLKx} frequency and VDD supply voltage conditions summarized in [Table 17](#), with the following configuration:

- Output speed is set to OSPEEDRy[1:0] = 10
- Capacitive load C=30 pF
- Measurement points are performed at CMOS levels: $0.5V_{DD}$

Refer to [Section 6.3.16: I/O port characteristics](#) for more details on the input/output alternate function characteristics (SCK,SD,WS).

Table 69. SAI characteristics⁽¹⁾

Symbol	Parameter	Conditions	Min	Max	Unit
f_{MCKL}	SAI Main clock output	-	256 * 8K	256 * $F_s^{(2)}$	MHz
F_{SCK}	SAI clock frequency	Master data: 32 bits	-	128 * F_s	MHz
		Slave data: 32 bits	-	128 * F_s	
$t_{v(FS)}$	FS valid time	Master mode 2.7 V $\leq V_{DD} \leq$ 3.6 V	-	19	ns
		Master mode 1.71 V $\leq V_{DD} \leq$ 3.6 V	-	28	
$t_{h(FS)}$	FS hold time	Master mode	13	-	
		Slave mode	0	-	
$t_{su(FS)}$	FS setup time	Slave mode	3	-	
$t_{su(SD_A_MR)}$	Data input setup time	Master receiver	0.5	-	
$t_{su(SD_B_SR)}$		Slave receiver	1.5	-	
$t_{h(SD_A_MR)}$	Data input hold time	Master receiver	5	-	
$t_{h(SD_B_SR)}$		Slave receiver	2.5	-	
$t_{v(SD_B_ST)}$	Data output valid time	Slave transmitter (after enable edge) 2.7 V $\leq V_{DD} \leq$ 3.6 V	-	15	
		Slave transmitter (after enable edge) 1.71 V $\leq V_{DD} \leq$ 3.6 V	-	28	
$t_{h(SD_B_ST)}$	Data output hold time	Slave transmitter (after enable edge)	10	-	
$t_{v(SD_A_MT)}$	Data output valid time	Master transmitter (after enable edge) 2.7 V $\leq V_{DD} \leq$ 3.6 V	-	15	
		Master transmitter (after enable edge) 1.71 V $\leq V_{DD} \leq$ 3.6 V	-	29	
$t_{h(SD_A_MT)}$	Data output hold time	Master transmitter (after enable edge)	13	-	

1. Guaranteed by characterization results.
2. 256 * F_s maximum corresponds to 45 MHz (APB2 maximum frequency)

Figure 45. SAI master timing waveforms

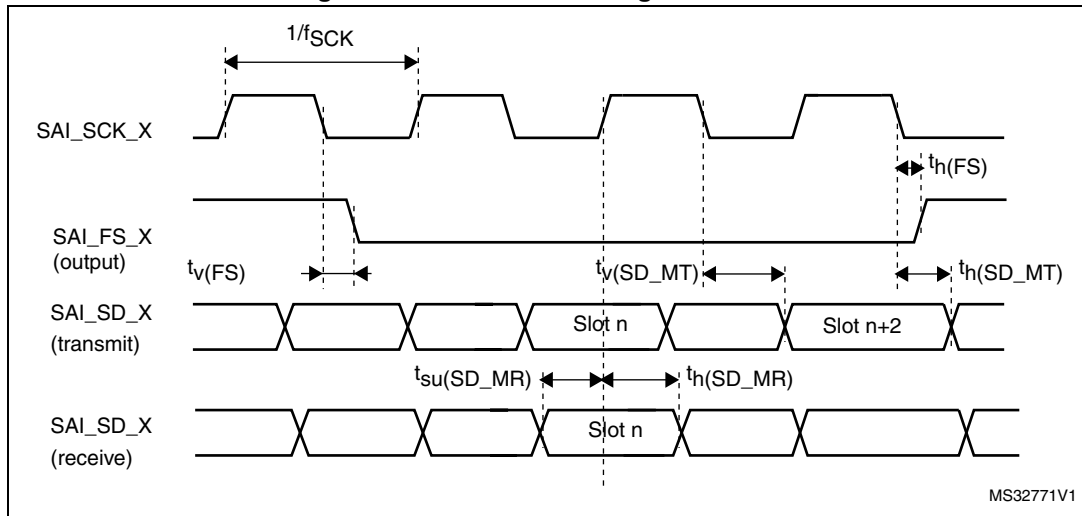
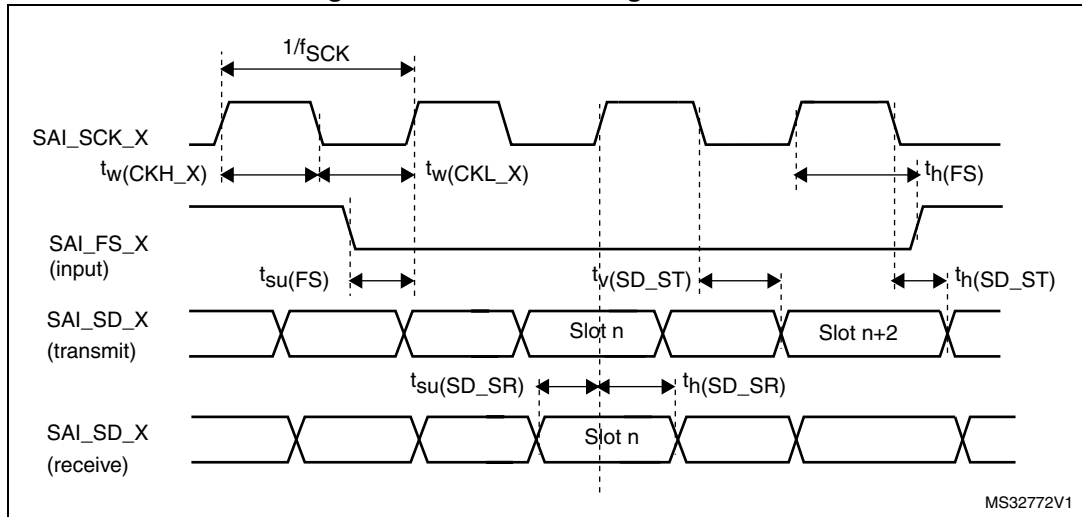

Figure 46. SAI slave timing waveforms



QSPI interface characteristics

Unless otherwise specified, the parameters given in the following tables for QSPI are derived from tests performed under the ambient temperature, f_{AHB} frequency and V_{DD} supply voltage conditions summarized in [Table 17](#), with the following configuration:

- Output speed is set to OSPEEDRy[1:0] = 11
- Capacitive load C=20pF
- Measurement points are done at CMOS levels: 0.5VDD

Refer to [Section 6.3.16: I/O port characteristics](#) for more details on the input/output alternate function characteristics.

Table 70. QSPI dynamic characteristics in SDR mode⁽¹⁾

Symbol	Parameter	Conditions	Min	Typ	Max	Unit
f_{SCK} $1/t_{c(SCK)}$	QSPI clock frequency	$2.7 V < V_{DD} < 3.6 V$ $C_{load} = 20 pF$	-	-	100	MHz
		$1.71 V < V_{DD} < 3.6 V$ $C_{load} = 15 pF$	-	-	80	
$t_{w(CKH)}$	QSPI clock high and low	-	$t_{(CK)} / 2 - 1$	-	$t_{(CK)} / 2$	ns
$t_{w(CKL)}$			$t_{(CK)} / 2$	-	$t_{(CK)} / 2 + 1$	
$t_{s(IN)}$	Data input setup time	-	1.5	-	-	
$t_{h(IN)}$	Data input hold time	-	3	-	-	
$t_{v(OUT)}$	Data output valid time	$2.7 V < V_{DD} < 3.6 V$	-	0.5	1	
		$1.71 V < V_{DD} < 3.6 V$	-	0.5	3	
$t_{h(OUT)}$	Data output hold time	-	0	-	0	

1. Guaranteed by characterization results.

Table 71. QSPI dynamic characteristics in DDR mode⁽¹⁾

Symbol	Parameter	Conditions	Min	Typ	Max	Unit
f_{SCK} $1/t_{c(SCK)}$	QSPI clock frequency	$2.7 V < V_{DD} < 3.6 V$ $C_{load} = 20 pF$	-	-	80	MHz
		$1.71 V < V_{DD} < 3.6 V$ $C_{load} = 15 pF$	-	-	70	

Table 71. QSPI dynamic characteristics in DDR mode⁽¹⁾ (continued)

Symbol	Parameter	Conditions	Min	Typ	Max	Unit
$t_{w(CKH)}$	QSPI clock high and low time	-	$t_{(CK)} / 2 - 1$	-	$t_{(CK)} / 2$	ns
$t_{w(CKL)}$			$t_{(CK)} / 2$	-	$t_{(CK)} / 2 + 1$	
$t_{sr(IN)}$, $t_{sf(IN)}$	Data input setup time	$2.7\text{ V} < V_{DD} < 3.6\text{ V}$	0.5	-	-	
		$1.71\text{ V} < V_{DD} < 3.6\text{ V}$	0.5	-	-	
$t_{hr(IN)}$, $t_{hf(IN)}$	Data input hold time	$2.7\text{ V} < V_{DD} < 3.6\text{ V}$	2	-	-	
		$1.71\text{ V} < V_{DD} < 3.6\text{ V}$	2	-	-	
$t_{vr(OUT)}$, $t_{vf(OUT)}$	Data output valid time	$2.7\text{ V} < V_{DD} < 3.6\text{ V}$	-	8.5	9	
		$1.71\text{ V} < V_{DD} < 3.6\text{ V}$	-	8.5	11.5	
$t_{hr(OUT)}$, $t_{hf(OUT)}$	Data output hold time	-	7.5	-	-	

1. Guaranteed by characterization results.

USB OTG full speed (FS) characteristics

This interface is present in USB OTG FS controller.

Table 72. USB OTG FS startup time

Symbol	Parameter	Max	Unit
$t_{STARTUP}^{(1)}$	USB OTG FS transceiver startup time	1	µs

1. Guaranteed by design.

Table 73. USB OTG FS DC electrical characteristics

Symbol	Parameter	Conditions	Min. ⁽¹⁾	Typ.	Max. ⁽¹⁾	Unit	
Input levels	V_{DD}	USB OTG FS operating voltage	3.0 ⁽²⁾	-	3.6	V	
	$V_{DI}^{(3)}$	Differential input sensitivity	I(USB_FS_DP/DM)	0.2	-	-	V
	$V_{CM}^{(3)}$	Differential common mode range	Includes V_{DI} range	0.8	-	2.5	
	$V_{SE}^{(3)}$	Single ended receiver threshold		1.3	-	2.0	
Output levels	V_{OL}	Static output level low	R_L of 1.5 kΩ to 3.6 V ⁽⁴⁾	-	-	0.3	V
	V_{OH}	Static output level high	R_L of 15 kΩ to $V_{SS}^{(4)}$	2.8	-	3.6	
R_{PD}	PA11, PA12 (USB_FS_DM/DP)	$V_{IN} = V_{DD}$	17	21	24	kΩ	
	PA9 (OTG_FS_VBUS)		0.65	1.1	2.0		
R_{PU}	PA11, PA12 (USB_FS_DM/DP)	$V_{IN} = V_{SS}$	1.5	1.8	2.1		
	PA9 (OTG_FS_VBUS)	$V_{IN} = V_{SS}$	0.25	0.37	0.55		

1. All the voltages are measured from the local ground potential.

2. The USB OTG FS functionality is ensured down to 2.7 V but not the full USB full speed electrical characteristics which are degraded in the 2.7-to-3.0 V V_{DD} voltage range.
3. Guaranteed by design.
4. R_L is the load connected on the USB OTG FS drivers.

Note: When VBUS sensing feature is enabled, PA9 should be left at their default state (floating input), not as alternate function. A typical 200 μ A current consumption of the embedded sensing block (current to voltage conversion to determine the different sessions) can be observed on PA9 when the feature is enabled.

Figure 47. USB OTG FS timings: definition of data signal rise and fall time

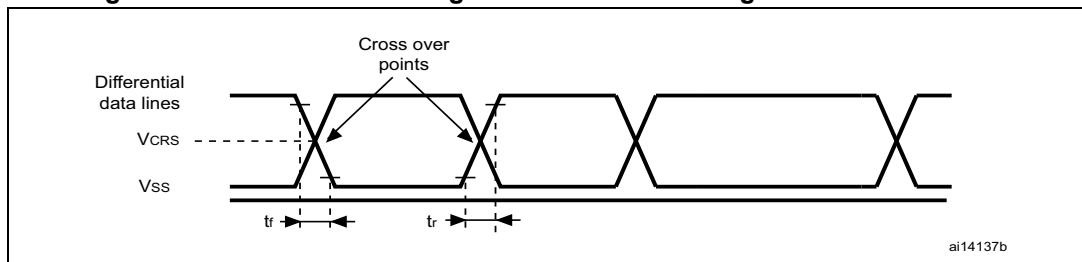

Table 74. USB OTG FS electrical characteristics⁽¹⁾

Driver characteristics					
Symbol	Parameter	Conditions	Min	Max	Unit
t_r	Rise time ⁽²⁾	$C_L = 50 \text{ pF}$	4	20	ns
t_f	Fall time ⁽²⁾	$C_L = 50 \text{ pF}$	4	20	ns
t_{rfm}	Rise/ fall time matching	t_r/t_f	90	110	%
V_{CRS}	Output signal crossover voltage		1.3	2.0	V

1. Guaranteed by design.
2. Measured from 10% to 90% of the data signal. For more detailed informations, refer to USB Specification - Chapter 7 (version 2.0).

CAN (controller area network) interface

Refer to [Section 6.3.16: I/O port characteristics](#) for more details on the input/output alternate function characteristics (CANx_TX and CANx_RX).

6.3.20 12-bit ADC characteristics

Unless otherwise specified, the parameters given in [Table 75](#) are derived from tests performed under the ambient temperature, f_{PCLK2} frequency and V_{DDA} supply voltage conditions summarized in [Table 17](#).

Table 75. ADC characteristics

Symbol	Parameter	Conditions	Min	Typ	Max	Unit
V_{DDA}	Power supply	$V_{DDA} - V_{REF+} < 1.2\text{ V}$	1.7 ⁽¹⁾	-	3.6	V
V_{REF+}	Positive reference voltage		1.7 ⁽¹⁾	-	V_{DDA}	
V_{REF-}	Negative reference voltage	-	-	0	-	
f_{ADC}	ADC clock frequency	$V_{DDA} = 1.7^{(1)}\text{ to }2.4\text{ V}$	0.6	15	18	MHz
		$V_{DDA} = 2.4\text{ to }3.6\text{ V}$	0.6	30	36	MHz
$f_{TRIG}^{(2)}$	External trigger frequency	$f_{ADC} = 30\text{ MHz}$, 12-bit resolution	-	-	1764	kHz
		-	-	-	17	$1/f_{ADC}$
V_{AIN}	Conversion voltage range ⁽³⁾	-	0 (V_{SSA} or V_{REF-} tied to ground)	-	V_{REF+}	V
$R_{AIN}^{(2)}$	External input impedance	See Equation 1 for details	-	-	50	k Ω
$R_{ADC}^{(2)(4)}$	Sampling switch resistance	-	-	-	6	k Ω
$C_{ADC}^{(2)}$	Internal sample and hold capacitor	-	-	4	7	pF
$t_{lat}^{(2)}$	Injection trigger conversion latency	$f_{ADC} = 30\text{ MHz}$	-	-	0.100	μs
		-	-	-	3 ⁽⁵⁾	$1/f_{ADC}$
$t_{latr}^{(2)}$	Regular trigger conversion latency	$f_{ADC} = 30\text{ MHz}$	-	-	0.067	μs
		-	-	-	2 ⁽⁵⁾	$1/f_{ADC}$
$t_S^{(2)}$	Sampling time	$f_{ADC} = 30\text{ MHz}$	0.100	-	16	μs
		-	3	-	480	$1/f_{ADC}$
$t_{STAB}^{(2)}$	Power-up time	-	-	2	3	μs
$t_{CONV}^{(2)}$	Total conversion time (including sampling time)	$f_{ADC} = 30\text{ MHz}$ 12-bit resolution	0.50	-	16.40	μs
		$f_{ADC} = 30\text{ MHz}$ 10-bit resolution	0.43	-	16.34	μs
		$f_{ADC} = 30\text{ MHz}$ 8-bit resolution	0.37	-	16.27	μs
		$f_{ADC} = 30\text{ MHz}$ 6-bit resolution	0.30	-	16.20	μs
		9 to 492 (t_S for sampling +n-bit resolution for successive approximation)				

Table 75. ADC characteristics (continued)

Symbol	Parameter	Conditions	Min	Typ	Max	Unit
$f_S^{(2)}$	Sampling rate ($f_{ADC} = 30$ MHz, and $t_S = 3$ ADC cycles)	12-bit resolution Single ADC	-	-	2	Msp/s
$I_{VREF+}^{(2)}$	ADC V_{REF} DC current consumption in conversion mode	-	-	300	500	μ A
$I_{VDDA}^{(2)}$	ADC V_{DDA} DC current consumption in conversion mode	-	-	1.6	1.8	mA

- V_{DDA} minimum value of 1.7 V is possible with the use of an external power supply supervisor (refer to [Section 3.17.2: Internal reset OFF](#)).
- Guaranteed by characterization results.
- V_{REF+} is internally connected to V_{DDA} and V_{REF-} is internally connected to V_{SSA} .
- R_{ADC} maximum value is given for $V_{DD}=1.7$ V, and minimum value for $V_{DD}=3.3$ V.
- For external triggers, a delay of $1/f_{PCLK2}$ must be added to the latency specified in [Table 75](#).

Equation 1: R_{AIN} max formula

$$R_{AIN} = \frac{(k - 0.5)}{f_{ADC} \times C_{ADC} \times \ln(2^{N+2})} - R_{ADC}$$

The formula above ([Equation 1](#)) is used to determine the maximum external impedance allowed for an error below 1/4 of LSB. N = 12 (from 12-bit resolution) and k is the number of sampling periods defined in the ADC_SMPR1 register.

Table 76. ADC accuracy at $f_{ADC} = 18$ MHz⁽¹⁾

Symbol	Parameter	Test conditions	Typ	Max ⁽²⁾	Unit
ET	Total unadjusted error	$f_{ADC} = 18$ MHz $V_{DDA} = 1.7$ to 3.6 V $V_{REF} = 1.7$ to 3.6 V $V_{DDA} - V_{REF} < 1.2$ V	± 3	± 4	LSB
EO	Offset error		± 2	± 3	
EG	Gain error		± 1	± 3	
ED	Differential linearity error		± 1	± 2	
EL	Integral linearity error		± 2	± 3	

- Better performance could be achieved in restricted V_{DD} , frequency and temperature ranges.
- Guaranteed by characterization results.

Table 77. ADC accuracy at $f_{ADC} = 30\text{ MHz}^{(1)}$

Symbol	Parameter	Test conditions	Typ	Max ⁽²⁾	Unit
ET	Total unadjusted error	$f_{ADC} = 30\text{ MHz}$, $R_{AIN} < 10\text{ k}\Omega$, $V_{DDA} = 2.4\text{ to }3.6\text{ V}$, $V_{REF} = 1.7\text{ to }3.6\text{ V}$, $V_{DDA} - V_{REF} < 1.2\text{ V}$	± 2	± 5	LSB
EO	Offset error		± 1.5	± 2.5	
EG	Gain error		± 1.5	± 4	
ED	Differential linearity error		± 1	± 2	
EL	Integral linearity error		± 1.5	± 3	

- Better performance could be achieved in restricted V_{DD} , frequency and temperature ranges.
- Guaranteed by characterization results.

Table 78. ADC accuracy at $f_{ADC} = 36\text{ MHz}^{(1)}$

Symbol	Parameter	Test conditions	Typ	Max ⁽²⁾	Unit
ET	Total unadjusted error	$f_{ADC} = 36\text{ MHz}$, $V_{DDA} = 2.4\text{ to }3.6\text{ V}$, $V_{REF} = 1.7\text{ to }3.6\text{ V}$, $V_{DDA} - V_{REF} < 1.2\text{ V}$	± 4	± 7	LSB
EO	Offset error		± 2	± 3	
EG	Gain error		± 3	± 6	
ED	Differential linearity error		± 2	± 3	
EL	Integral linearity error		± 3	± 6	

- Better performance could be achieved in restricted V_{DD} , frequency and temperature ranges.
- Guaranteed by characterization results.

Table 79. ADC dynamic accuracy at $f_{ADC} = 18\text{ MHz}$ - limited test conditions⁽¹⁾

Symbol	Parameter	Test conditions	Min	Typ	Max	Unit
ENOB	Effective number of bits	$f_{ADC} = 18\text{ MHz}$ $V_{DDA} = V_{REF+} = 1.7\text{ V}$ Input Frequency = 20 kHz Temperature = 25 °C	10.3	10.4	-	bits
SINAD	Signal-to-noise and distortion ratio		64	64.2	-	dB
SNR	Signal-to-noise ratio		64	65	-	
THD	Total harmonic distortion		-	-72	-67	

- Guaranteed by characterization results.

Table 80. ADC dynamic accuracy at $f_{ADC} = 36\text{ MHz}$ - limited test conditions⁽¹⁾

Symbol	Parameter	Test conditions	Min	Typ	Max	Unit
ENOB	Effective number of bits	$f_{ADC} = 36\text{ MHz}$ $V_{DDA} = V_{REF+} = 3.3\text{ V}$ Input Frequency = 20 kHz Temperature = 25 °C	10.6	10.8	-	bits
SINAD	Signal-to noise and distortion ratio		66	67	-	dB
SNR	Signal-to noise ratio		64	68	-	
THD	Total harmonic distortion		-	-72	-70	

- Guaranteed by characterization results.

Note: ADC accuracy vs. negative injection current: injecting a negative current on any analog input pins should be avoided as this significantly reduces the accuracy of the conversion being performed on another analog input. It is recommended to add a Schottky diode (pin to ground) to analog pins which may potentially inject negative currents.

Any positive injection current within the limits specified for $I_{INJ(PIN)}$ and $\Sigma I_{INJ(PIN)}$ in [Section 6.3.16](#) does not affect the ADC accuracy.

Figure 48. ADC accuracy characteristics

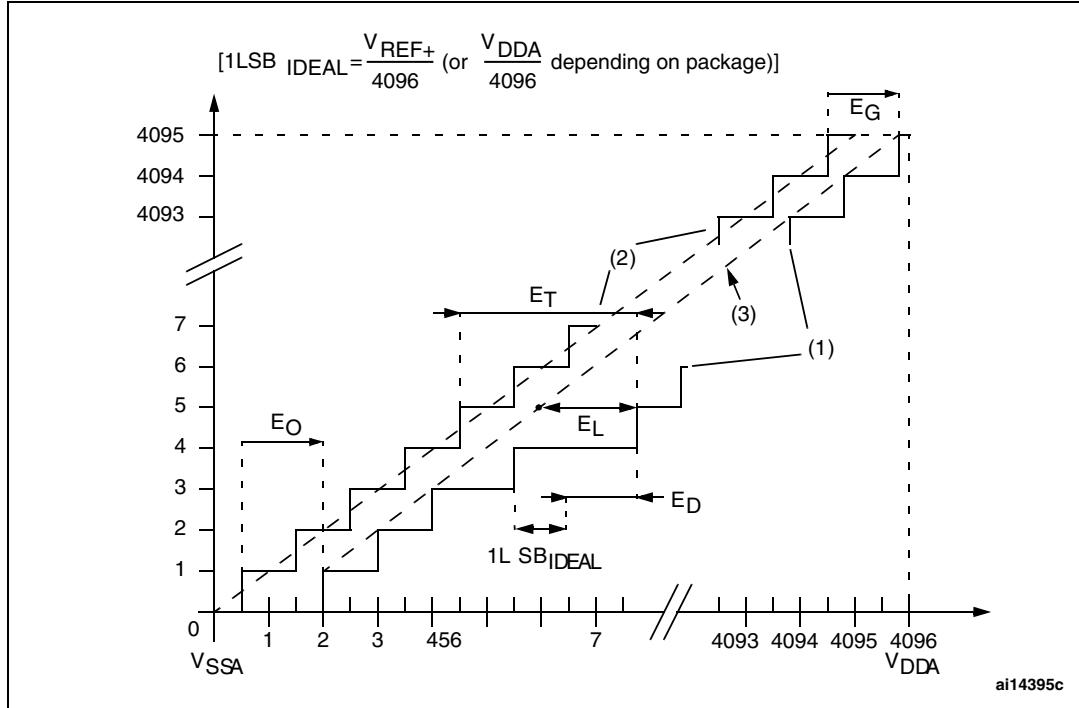

1. See also [Table 77](#).
2. Example of an actual transfer curve.
3. Ideal transfer curve.
4. End point correlation line.
5. E_T = Total Unadjusted Error: maximum deviation between the actual and the ideal transfer curves.
 E_O = Offset Error: deviation between the first actual transition and the first ideal one.
 E_G = Gain Error: deviation between the last ideal transition and the last actual one.
 E_D = Differential Linearity Error: maximum deviation between actual steps and the ideal one.
 E_L = Integral Linearity Error: maximum deviation between any actual transition and the end point correlation line.

Figure 49. Typical connection diagram using the ADC

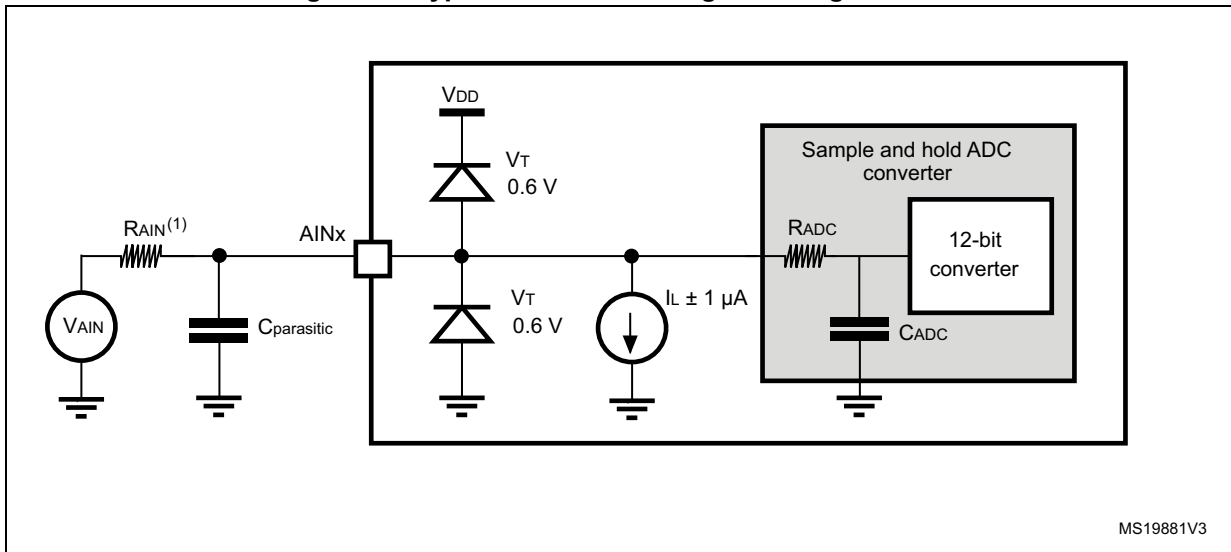

1. Refer to [Table 75](#) for the values of R_{AIN} , R_{ADC} and C_{ADC} .
2. $C_{parasitic}$ represents the capacitance of the PCB (dependent on soldering and PCB layout quality) plus the pad capacitance (roughly 5 pF). A high $C_{parasitic}$ value downgrades conversion accuracy. To remedy this, f_{ADC} should be reduced.

General PCB design guidelines

Power supply decoupling should be performed as shown in [Figure 50](#) or [Figure 51](#), depending on whether V_{REF+} is connected to V_{DDA} or not. The 10 nF capacitors should be ceramic (good quality). They should be placed them as close as possible to the chip.

Figure 50. Power supply and reference decoupling (V_{REF+} not connected to V_{DDA})

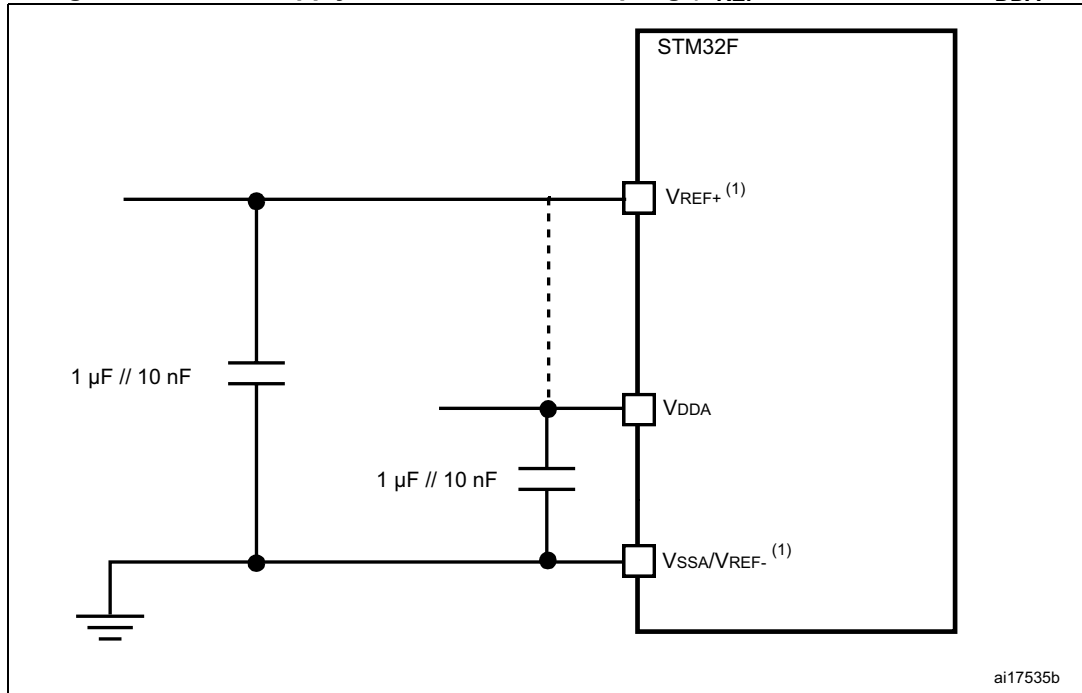

1. V_{REF+} and V_{REF-} inputs are both available on UFBGA100. V_{REF+} is also available on LQFP100. When V_{REF+} and V_{REF-} are not available, they are internally connected to V_{DDA} and V_{SSA} .

Figure 51. Power supply and reference decoupling (V_{REF+} connected to V_{DDA})

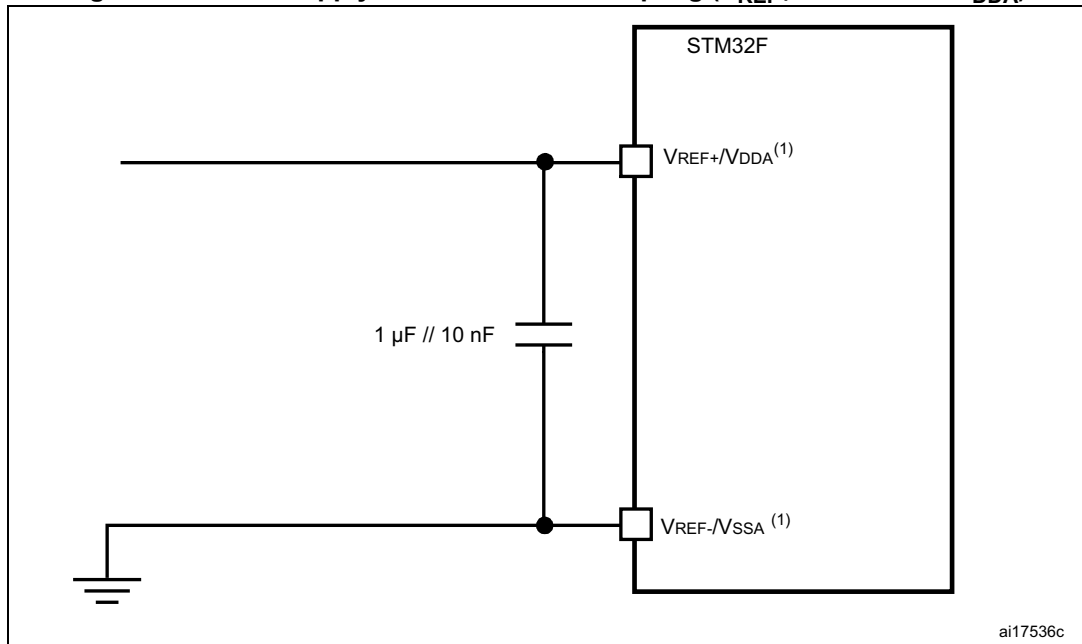

1. V_{REF+} and V_{REF-} inputs are both available on UFBGA100. V_{REF+} is also available on LQFP100. When V_{REF+} and V_{REF-} are not available, they are internally connected to V_{DDA} and V_{SSA} .

6.3.21 Temperature sensor characteristics

Table 81. Temperature sensor characteristics

Symbol	Parameter	Min	Typ	Max	Unit
$T_L^{(1)}$	V_{SENSE} linearity with temperature	-	± 1	± 2	$^{\circ}C$
Avg_Slope ⁽¹⁾	Average slope	-	2.5	-	mV/ $^{\circ}C$
$V_{25}^{(1)}$	Voltage at 25 $^{\circ}C$	-	0.76	-	V
$t_{START}^{(2)}$	Startup time	-	6	10	μs
$T_{S_temp}^{(2)}$	ADC sampling time when reading the temperature (1 $^{\circ}C$ accuracy)	10	-	-	μs

1. Guaranteed by characterization results.
2. Guaranteed by design.

Table 82. Temperature sensor calibration values

Symbol	Parameter	Memory address
TS_CAL1	TS ADC raw data acquired at temperature of 30 $^{\circ}C$, $V_{DDA} = 3.3 V$	0x1FFF 7A2C - 0x1FFF 7A2D
TS_CAL2	TS ADC raw data acquired at temperature of 110 $^{\circ}C$, $V_{DDA} = 3.3 V$	0x1FFF 7A2E - 0x1FFF 7A2F

6.3.22 V_{BAT} monitoring characteristics

Table 83. V_{BAT} monitoring characteristics

Symbol	Parameter	Min	Typ	Max	Unit
R	Resistor bridge for V_{BAT}	-	50	-	K Ω
Q	Ratio on V_{BAT} measurement	-	4	-	
$E_r^{(1)}$	Error on Q	-1	-	+1	%
$T_{S_vbat}^{(2)(2)}$	ADC sampling time when reading the V_{BAT} 1 mV accuracy	5	-	-	μ s

1. Guaranteed by design.
2. Shortest sampling time can be determined in the application by multiple iterations.

6.3.23 Embedded reference voltage

The parameters given in [Table 84](#) are derived from tests performed under ambient temperature and V_{DD} supply voltage conditions summarized in [Table 17](#).

Table 84. Embedded internal reference voltage

Symbol	Parameter	Conditions	Min	Typ	Max	Unit
V_{REFINT}	Internal reference voltage	$-40\text{ }^\circ\text{C} < T_A < +125\text{ }^\circ\text{C}$	1.18	1.21	1.24	V
$T_{S_refint}^{(1)}$	ADC sampling time when reading the internal reference voltage	-	10	-	-	μ s
$V_{RERINT_s}^{(2)}$	Internal reference voltage spread over the temperature range	$V_{DD} = 3V \pm 10\text{mV}$	-	3	5	mV
$T_{Ccoeff}^{(2)}$	Temperature coefficient	-	-	30	50	ppm/ $^\circ\text{C}$
$t_{START}^{(2)}$	Startup time	-	-	6	10	μ s

1. Shortest sampling time can be determined in the application by multiple iterations.
2. Guaranteed by design

Table 85. Internal reference voltage calibration values

Symbol	Parameter	Memory address
V_{REFIN_CAL}	Raw data acquired at temperature of $30\text{ }^\circ\text{C}$ $V_{DDA} = 3.3\text{ V}$	0x1FFF 7A2A - 0x1FFF 7A2B

6.3.24 DAC electrical characteristics

Table 86. DAC characteristics

Symbol	Parameter	Conditions	Min	Typ	Max	Unit	Comments	
V _{DDA}	Analog supply voltage	-	1.7 ⁽¹⁾	-	3.6	V		
V _{REF+}	Reference supply voltage	-	1.7 ⁽¹⁾	-	3.6	V	V _{REF+} ≤ V _{DDA}	
V _{SSA}	Ground	-	0	-	0	V	-	
R _{LOAD} ⁽²⁾	Resistive load	DAC output buffer ON	R _{LOAD} connected to V _{SSA}	5	-	-	kΩ	-
			R _{LOAD} connected to V _{DDA}	25	-	-	kΩ	-
R _O ⁽²⁾	Impedance output with buffer OFF	-	-	-	15	kΩ	When the buffer is OFF, the Minimum resistive load between DAC_OUT and V _{SS} to have a 1% accuracy is 1.5 MΩ	
C _{LOAD} ⁽²⁾	Capacitive load	-	-	-	50	pF	Maximum capacitive load at DAC_OUT pin (when the buffer is ON).	
DAC_OUT _{min} ⁽²⁾	Lower DAC_OUT voltage with buffer ON	-	0.2	-	-	V	It gives the maximum output excursion of the DAC. It corresponds to 12-bit input code (0x0E0) to (0xF1C) at V _{REF+} = 3.6 V and (0x1C7) to (0xE38) at V _{REF+} = 1.7 V	
DAC_OUT _{max} ⁽²⁾	Higher DAC_OUT voltage with buffer ON	-	-	-	V _{DDA} - 0.2	V		
DAC_OUT _{min} ⁽²⁾	Lower DAC_OUT voltage with buffer OFF	-	-	0.5	-	mV	It gives the maximum output excursion of the DAC.	
DAC_OUT _{max} ⁽²⁾	Higher DAC_OUT voltage with buffer OFF	-	-	-	V _{REF+} - 1LSB	V		
I _{VREF+} ⁽⁴⁾	DAC DC V _{REF} current consumption in quiescent mode (Standby mode)	-	-	170	240	μA	With no load, worst code (0x800) at V _{REF+} = 3.6 V in terms of DC consumption on the inputs	
		-	-	50	75		With no load, worst code (0xF1C) at V _{REF+} = 3.6 V in terms of DC consumption on the inputs	
I _{DDA} ⁽⁴⁾	DAC DC V _{DDA} current consumption in quiescent mode ⁽³⁾	-	-	280	380	μA	With no load, middle code (0x800) on the inputs	
		-	-	475	625	μA	With no load, worst code (0xF1C) at V _{REF+} = 3.6 V in terms of DC consumption on the inputs	



Table 86. DAC characteristics (continued)

Symbol	Parameter	Conditions	Min	Typ	Max	Unit	Comments
DNL ⁽⁴⁾	Differential non linearity Difference between two consecutive code-1LSB)	-	-	-	±0.5	LSB	Given for the DAC in 10-bit configuration.
		-	-	-	±2	LSB	Given for the DAC in 12-bit configuration.
INL ⁽⁴⁾	Integral non linearity (difference between measured value at Code i and the value at Code i on a line drawn between Code 0 and last Code 1023)	-	-	-	±1	LSB	Given for the DAC in 10-bit configuration.
		-	-	-	±4	LSB	Given for the DAC in 12-bit configuration.
Offset ⁽⁴⁾	Offset error (difference between measured value at Code (0x800) and the ideal value = $V_{REF+}/2$)	-	-	-	±10	mV	Given for the DAC in 12-bit configuration
		-	-	-	±3	LSB	Given for the DAC in 10-bit at $V_{REF+} = 3.6\text{ V}$
		-	-	-	±12	LSB	Given for the DAC in 12-bit at $V_{REF+} = 3.6\text{ V}$
Gain error ⁽⁴⁾	Gain error	-	-	-	±0.5	%	Given for the DAC in 12-bit configuration
$t_{SETTLING}^{(4)}$	Settling time (full scale: for a 10-bit input code transition between the lowest and the highest input codes when DAC_OUT reaches final value ±4LSB)	-	-	3	6	µs	$C_{LOAD} \leq 50\text{ pF}$, $R_{LOAD} \geq 5\text{ k}\Omega$
THD ⁽⁴⁾	Total Harmonic Distortion Buffer ON	-	-	-	-	dB	$C_{LOAD} \leq 50\text{ pF}$, $R_{LOAD} \geq 5\text{ k}\Omega$
Update rate ⁽²⁾	Max frequency for a correct DAC_OUT change when small variation in the input code (from code i to i+1LSB)	-	-	-	1	MS/s	$C_{LOAD} \leq 50\text{ pF}$, $R_{LOAD} \geq 5\text{ k}\Omega$
$t_{WAKEUP}^{(4)}$	Wakeup time from off state (Setting the ENx bit in the DAC Control register)	-	-	6.5	10	µs	$C_{LOAD} \leq 50\text{ pF}$, $R_{LOAD} \geq 5\text{ k}\Omega$ input code between lowest and highest possible ones.
PSRR+ ⁽²⁾	Power supply rejection ratio (to V_{DDA}) (static DC measurement)	-	-	-67	-40	dB	No R_{LOAD} , $C_{LOAD} = 50\text{ pF}$

1. V_{DDA} minimum value of 1.7 V is obtained with the use of an external power supply supervisor (refer to [Section 3.17.2: Internal reset OFF](#)).
2. Guaranteed by design.
3. The quiescent mode corresponds to a state where the DAC maintains a stable output level to ensure that no dynamic consumption occurs.
4. Guaranteed by characterization results.

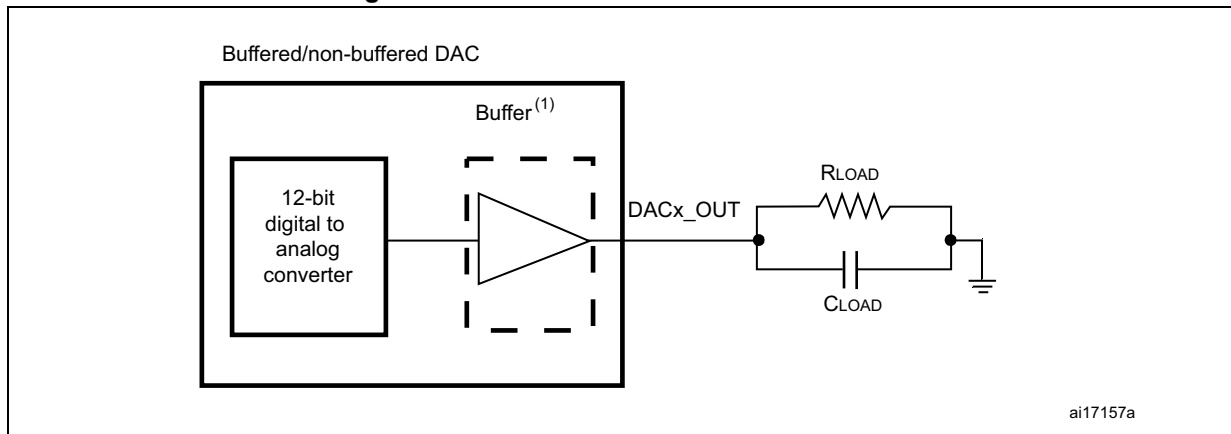
Figure 52. 12-bit buffered /non-buffered DAC

1. The DAC integrates an output buffer that can be used to reduce the output impedance and to drive external loads directly without the use of an external operational amplifier. The buffer can be bypassed by configuring the BOFFx bit in the DAC_CR register.

6.3.25 DFSDM characteristics

Unless otherwise specified, the parameters given in [Table 87](#) for DFSDM are derived from tests performed under the ambient temperature, f_{APB2} frequency and V_{DD} supply voltage conditions summarized in [Table 17: General operating conditions](#).

- Output speed is set to $OSPEEDRy[1:0] = 10$
- Capacitive load $C = 30$ pF
- Measurement points are done at CMOS levels: $0.5 * V_{DD}$

Refer to [Section 6.3.16: I/O port characteristics](#) for more details on the input/output alternate function characteristics (DFSDM_CKINy, DFSDM_DATINy, DFSDM_CKOUT for DFSDM).

Table 87. DFSDM characteristics⁽¹⁾

Symbol	Parameter	Conditions	Min	Typ	Max	Unit
$f_{DFSDMCLK}$	DFSDM clock	$1.71 < V_{DD} < 3.6$ V	-	-	f_{SYSCLK}	
f_{CKIN} ($1/T_{CKIN}$)	Input clock frequency	SPI mode (SITP[1:0] = 0,1), External clock mode (SPICKSEL[1:0] = 0, $1.71 < V_{DD} < 3.6$ V	-	-	20 ($f_{DFBDMCLK} / 4$)	MHz
		SPI mode (SITP[1:0] = 0,1), External clock mode (SPICKSEL[1:0] = 0, $2.7 < V_{DD} < 3.6$ V	-	-	20 ($f_{DFBDMCLK} / 4$)	
		SPI mode (SITP[1:0] = 0,1), Internal clock mode (SPICKSEL[1:0] ≠ 0, $1.71 < V_{DD} < 3.6$ V	-	-	20 ($f_{DFBDMCLK} / 4$)	
		SPI mode (SITP[1:0] = 0,1), Internal clock mode (SPICKSEL[1:0] ≠ 0, $2.7 < V_{DD} < 3.6$ V	-	-	20 ($f_{DFBDMCLK} / 4$)	
f_{CKOUT}	Output clock frequency	$1.71 < V_{DD} < 3.6$ V	-	-	20	
$DuCy_{CKOUT}$	Output clock frequency duty cycle	$1.71 < V_{DD} < 3.6$ V	45	50	55	%

Table 87. DFSDM characteristics⁽¹⁾ (continued)

Symbol	Parameter	Conditions	Min	Typ	Max	Unit
$t_{wh}(CKIN)$ $t_{wl}(CKIN)$	Input clock high and low time	SPI mode (SITP[1:0] = 01), External clock mode (SPICKSEL[1:0] = 0) $1.71 < V_{DD} < 3.6 V$	$t_{CKIN} / 2 - 0.5$	$t_{CKIN} / 2$	-	ns
t_{su}	Data input setup time	SPI mode (SITP[1:0]=01), External clock mode (SPICKSEL[1:0] = 0) $1.71 < V_{DD} < 3.6 V$	3.5	-	-	
t_h	Data input hold time	SPI mode (SITP[1:0]=01), External clock mode (SPICKSEL[1:0] = 0) $1.71 < V_{DD} < 3.6 V$	2.5	-	-	
$T_{Manchester}$	Manchester data period (recovered clock period)	Manchester mode (SITP[1:0] = 10 or 11), Internal clock mode (SPICKSEL[1:0] ≠ 0) $1.71 < V_{DD} < 3.6 V$	$(CKOUTDIV + 1) * t_{DFBDMCLK}$	-	$(2 * CKOUTDIV) * t_{DFBDMCLK}$	

1. Data based on characterization results.

Figure 16: DFSDM timing diagram

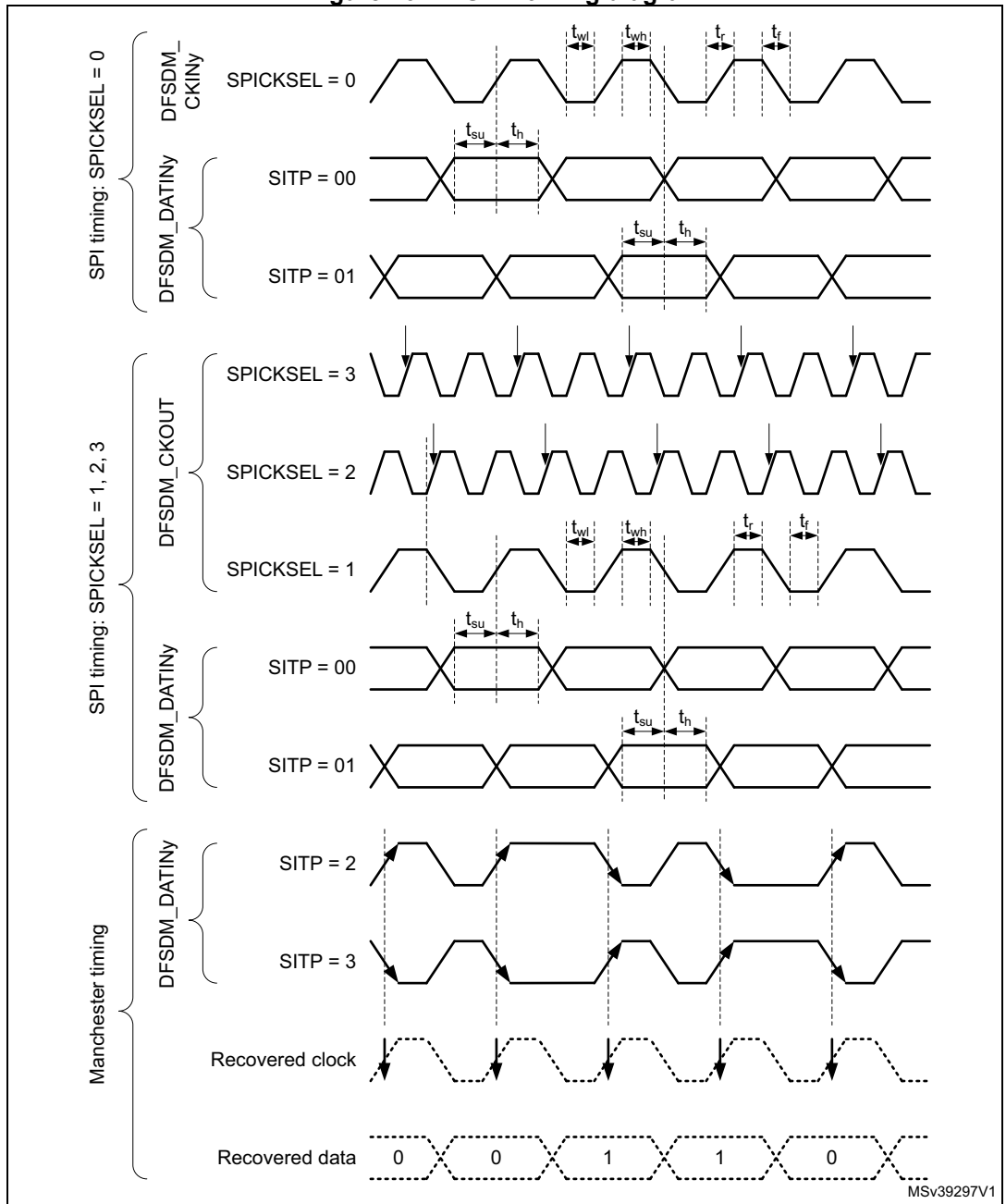

6.3.26 FSMC characteristics

Unless otherwise specified, the parameters given in [Table 88](#) to [Table 95](#) for the FSMC interface are derived from tests performed under the ambient temperature, f_{HCLK} frequency and V_{DD} supply voltage conditions summarized in [Table 16](#), with the following configuration:

- Output speed is set to $\text{OSPEEDRy}[1:0] = 10$
- Capacitance load $C = 30 \text{ pF}$
- Measurement points are done at CMOS levels: $0.5 \cdot V_{\text{DD}}$

Refer to [Section 6.3.16: I/O port characteristics](#) for more details on the input/output characteristics.

Asynchronous waveforms and timings

[Figure 53](#) through [Figure 56](#) represent asynchronous waveforms and [Table 88](#) through [Table 95](#) provide the corresponding timings. The results shown in these tables are obtained with the following FSMC configuration:

- $\text{AddressSetupTime} = 0x1$
- $\text{AddressHoldTime} = 0x1$
- $\text{DataSetupTime} = 0x1$ (except for asynchronous NWAIT mode, $\text{DataSetupTime} = 0x5$)
- $\text{BusTurnAroundDuration} = 0x0$

In all timing tables, the T_{HCLK} is the HCLK clock period.

Figure 53. Asynchronous non-multiplexed SRAM/PSRAM/NOR read waveforms

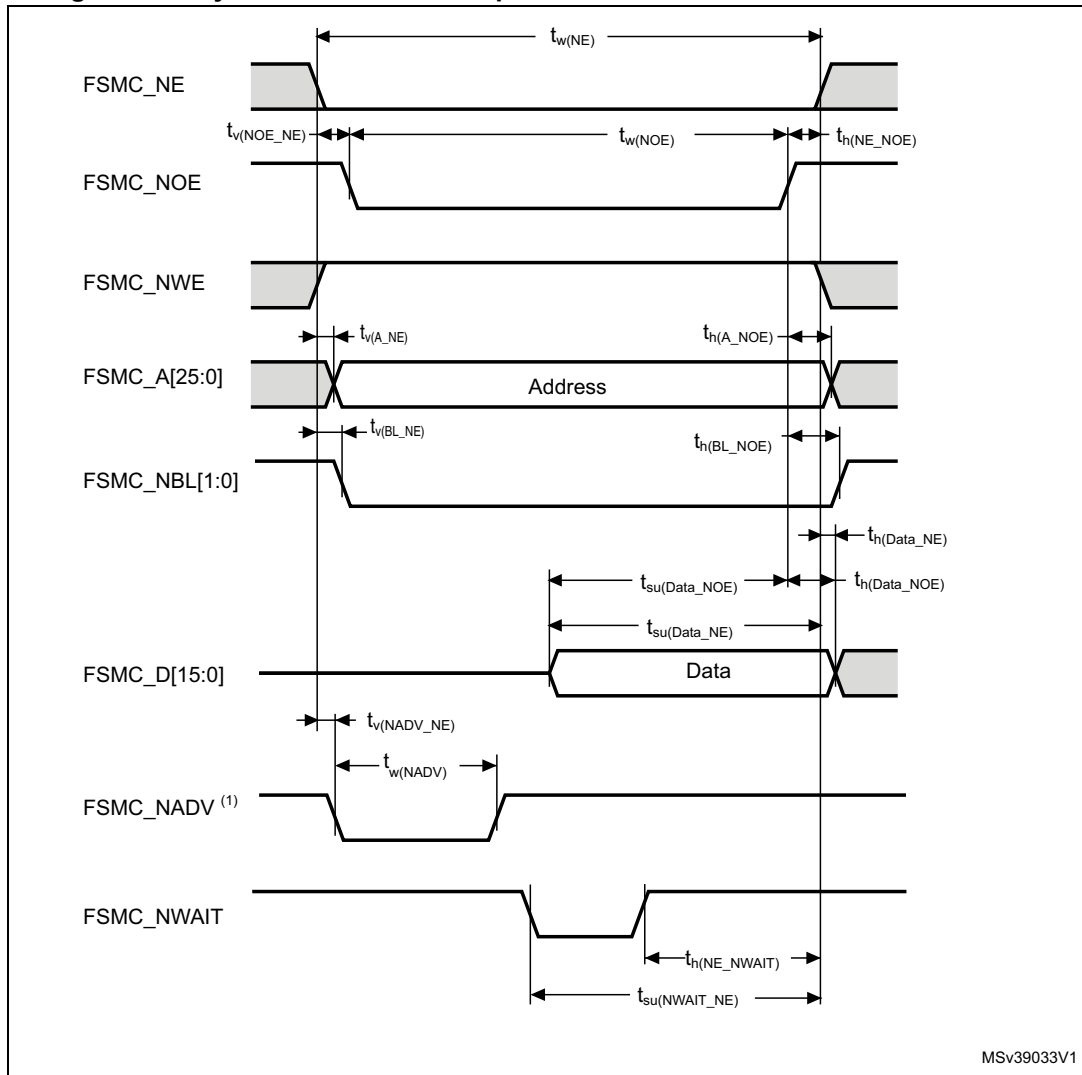

1. Mode 2/B, C and D only. In Mode 1, FSMC_NADV is not used.

Table 88. Asynchronous non-multiplexed SRAM/PSRAM/NOR - read timings⁽¹⁾⁽²⁾

Symbol	Parameter	Min	Max	Unit
$t_{w(NE)}$	FSMC_NE low time	$2 * t_{HCLK} - 1$	$2 * t_{HCLK} + 1$	ns
$t_{v(NOE_NE)}$	FSMC_NEx low to FSMC_NOE low	0	0.5	
$t_{w(NOE)}$	FSMC_NOE low time	$2 * t_{HCLK} - 1$	$2 * t_{HCLK} + 1$	
$t_{h(NE_NOE)}$	FSMC_NOE high to FSMC_NE high hold time	0	-	
$t_{v(A_NE)}$	FSMC_NEx low to FSMC_A valid	-	0.5	
$t_{h(A_NOE)}$	Address hold time after FSMC_NOE high	0	-	
$t_{v(BL_NE)}$	FSMC_NEx low to FSMC_BL valid	-	0.5	
$t_{h(BL_NOE)}$	FSMC_BL hold time after FSMC_NOE high	0	-	
$t_{su(Data_NE)}$	Data to FSMC_NEx high setup time	$t_{HCLK} - 2$	-	
$t_{su(Data_NOE)}$	Data to FSMC_NOEx high setup time	$t_{HCLK} - 2$	-	
$t_{h(Data_NOE)}$	Data hold time after FSMC_NOE high	0	-	
$t_{h(Data_NE)}$	Data hold time after FSMC_NEx high	0	-	
$t_{v(NADV_NE)}$	FSMC_NEx low to FSMC_NADV low	-	0	
$t_{w(NADV)}$	FSMC_NADV low time	-	$t_{HCLK} + 1$	

1. $C_L = 30$ pF.
2. Based on characterization.

Table 89. Asynchronous non-multiplexed SRAM/PSRAM/NOR read - NWAIT timings⁽¹⁾⁽²⁾

Symbol	Parameter	Min	Max	Unit
$t_{w(NE)}$	FSMC_NE low time	$7 * t_{HCLK} + 1$	$7 * t_{HCLK} + 1$	ns
$t_{w(NOE)}$	FSMC_NWE low time	$5 * t_{HCLK} - 1$	$5 * t_{HCLK} + 1$	
$t_{w(NWAIT)}$	FSMC_NWAIT low time	$t_{HCLK} - 0.5$	-	
$t_{su(NWAIT_NE)}$	FSMC_NWAIT valid before FSMC_NEx high	$5 * t_{HCLK} + 1.5$	-	
$t_{h(NE_NWAIT)}$	FSMC_NEx hold time after FSMC_NWAIT invalid	$4 * t_{HCLK} + 1$	-	

1. $C_L = 30$ pF.
2. Based on characterization.

Figure 54. Asynchronous non-multiplexed SRAM/PSRAM/NOR write waveforms

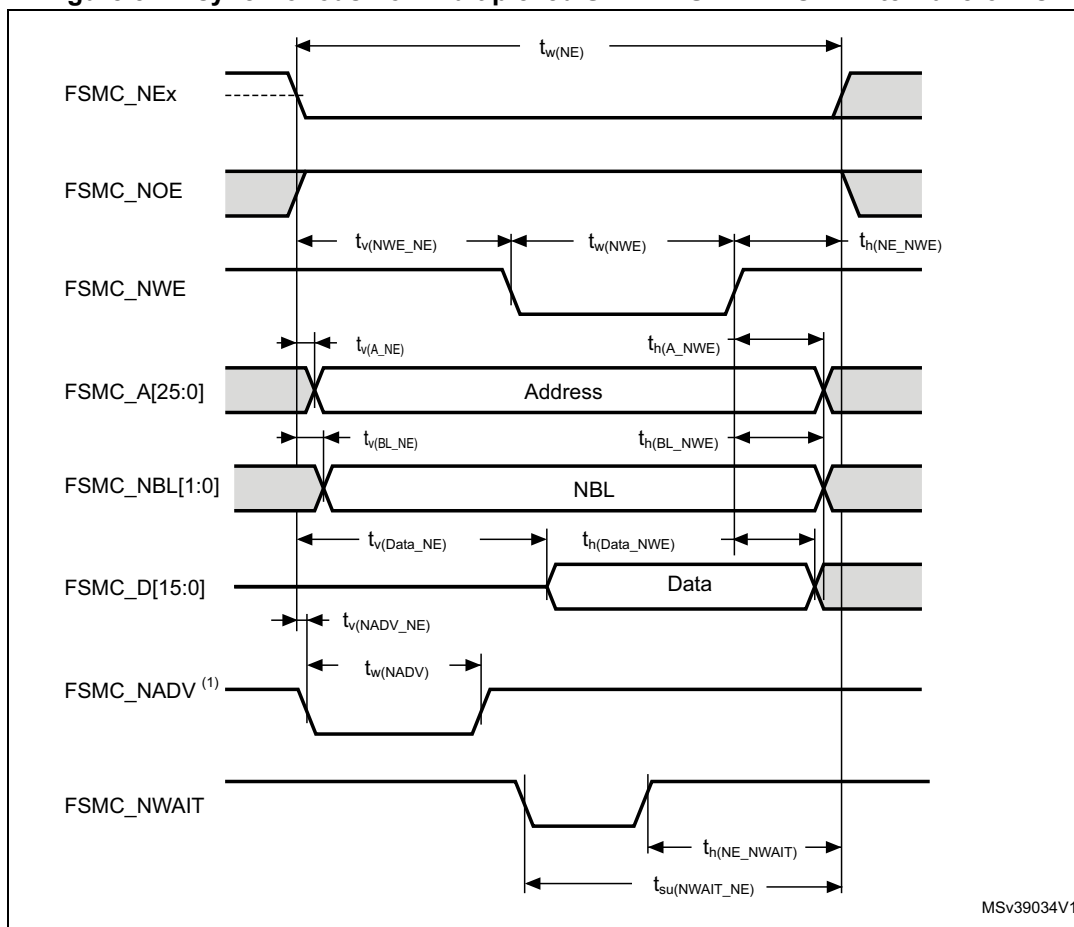

MSv39034V1

1. Mode 2/B, C and D only. In Mode 1, FSMC_NADV is not used.

Table 90. Asynchronous non-multiplexed SRAM/PSRAM/NOR write timings⁽¹⁾⁽²⁾

Symbol	Parameter	Min	Max	Unit
$t_{w(NE)}$	FSMC_NE low time	$3 * t_{Hclk} - 1$	$3 * t_{Hclk} - 1$	ns
$t_{v(NWE_NE)}$	FSMC_NEx low to FSMC_NWE low	$t_{HCLK} - 1$	$t_{HCLK} + 0.5$	
$t_{w(NWE)}$	FSMC_NWE low time	$t_{HCLK} - 1.5$	$t_{HCLK} + 0.5$	
$t_{h(NE_NWE)}$	FSMC_NWE high to FSMC_NE high hold time	t_{HCLK}	-	
$t_{v(A_NE)}$	FSMC_NEx low to FSMC_A valid	-	0	
$t_{h(A_NWE)}$	Address hold time after FSMC_NWE high	$t_{HCLK} - 0.5$	-	
$t_{v(BL_NE)}$	FSMC_NEx low to FSMC_BL valid	-	0.5	
$t_{h(BL_NWE)}$	FSMC_BL hold time after FSMC_NWE high	$t_{HCLK} - 0.5$	-	
$t_{v(Data_NE)}$	Data to FSMC_NEx low to Data valid	-	$t_{HCLK} + 2.5$	
$t_{h(Data_NWE)}$	Data hold time after FSMC_NWE high	t_{HCLK}	-	
$t_{v(NADV_NE)}$	FSMC_NEx low to FSMC_NADV low	-	0	
$t_{w(NADV)}$	FSMC_NADV low time	-	$t_{HCLK} + 1$	

- 1. $C_L = 30$ pF.
- 2. Based on characterization.

Table 91. Asynchronous non-multiplexed SRAM/PSRAM/NOR write - NWAIT timings⁽¹⁾⁽²⁾

Symbol	Parameter	Min	Max	Unit
$t_{w(NE)}$	FSMC_NE low time	$8 * t_{HCLK} - 1$	$8 * t_{HCLK} + 1$	ns
$t_{w(NWE)}$	FSMC_NWE low time	$6 * t_{HCLK} - 1.5$	$6 * t_{HCLK} + 0.5$	
$t_{su(NWAIT_NE)}$	FSMC_NWAIT valid before FSMC_NEx high	$6 * t_{HCLK} - 1$	-	
$t_h(NE_NWAIT)$	FSMC_NEx hold time after FSMC_NWAIT invalid	$4 * t_{HCLK} + 2$	-	

- 1. $C_L = 30$ pF.
- 2. Based on characterization.

Figure 55. Asynchronous multiplexed PSRAM/NOR read waveforms

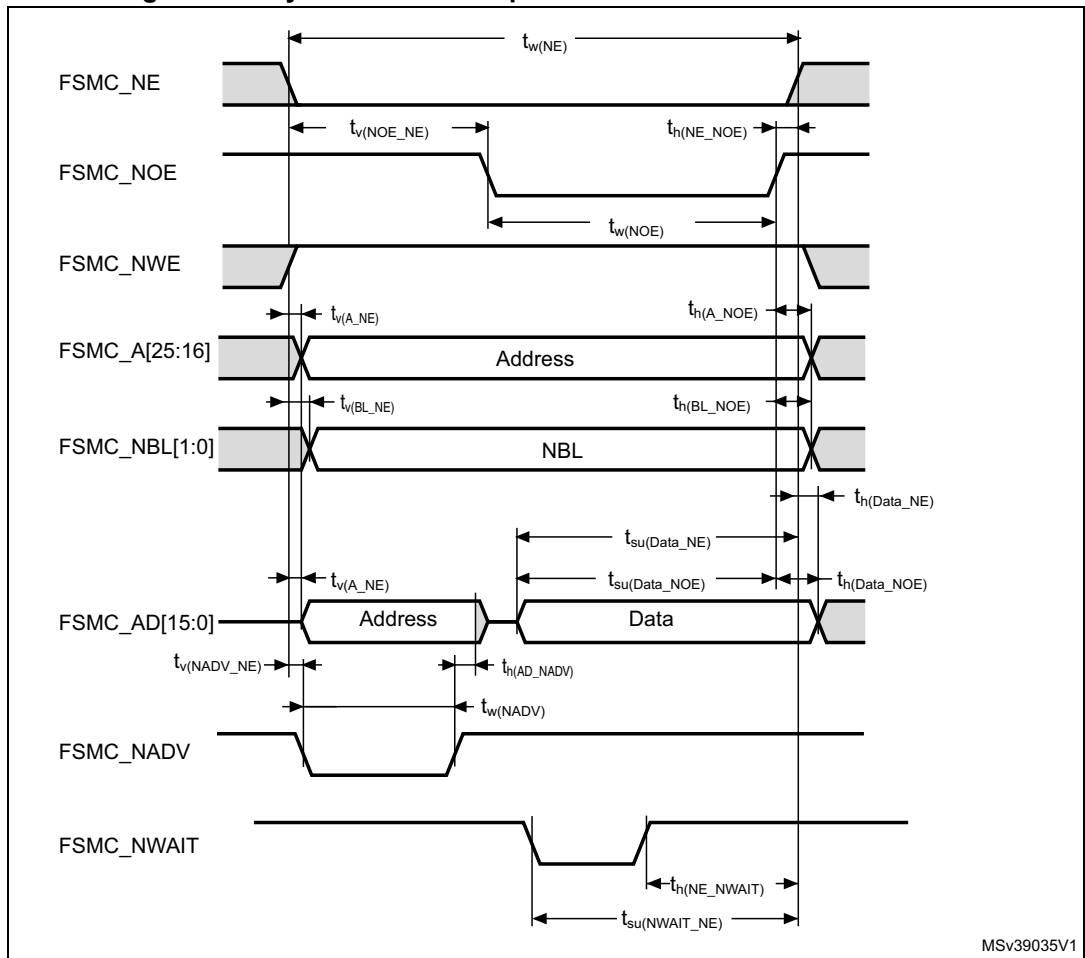

Table 92. Asynchronous multiplexed PSRAM/NOR read timings⁽¹⁾⁽²⁾

Symbol	Parameter	Min	Max	Unit
$t_{w(NE)}$	FSMC_NE low time	$3 * t_{HCLK} - 1$	$3 * t_{HCLK} + 1$	ns
$t_{v(NOE_NE)}$	FSMC_NEx low to FSMC_NOE low	$2 * t_{HCLK}$	$2 * t_{HCLK} + 0.5$	
$t_{w(NOE)}$	FSMC_NOE low time	$t_{HCLK} - 1$	$t_{HCLK} + 1$	
$t_{h(NE_NOE)}$	FSMC_NOE high to FSMC_NE high hold time	0	-	
$t_{v(A_NE)}$	FSMC_NEx low to FSMC_A valid	-	0.5	
$t_{v(NADV_NE)}$	FSMC_NEx low to FSMC_NADV low	0	0.5	
$t_{w(NADV)}$	FSMC_NADV low time	$t_{HCLK} - 0.5$	$t_{HCLK} + 1$	
$t_{h(AD_NADV)}$	FSMC_AD(address) valid hold time after FSMC_NADV high	$t_{HCLK} + 0.5$	-	
$t_{h(A_NOE)}$	Address hold time after FSMC_NOE high	$t_{HCLK} - 0.5$	-	
$t_{h(BL_NOE)}$	FSMC_BL time after FSMC_NOE high	0	-	
$t_{v(BL_NE)}$	FSMC_NEx low to FSMC_BL valid	-	0.5	
$t_{su(Data_NE)}$	Data to FSMC_NEx high setup time	$t_{HCLK} - 2$	-	
$t_{su(Data_NOE)}$	Data to FSMC_NOE high setup time	$t_{HCLK} - 2$	-	
$t_{h(Data_NE)}$	Data hold time after FSMC_NEx high	0	-	
$t_{h(Data_NOE)}$	Data hold time after FSMC_NOE high	0	-	

1. $C_L = 30$ pF.
2. Based on characterization.

Table 93. Asynchronous multiplexed PSRAM/NOR read-NWAIT timings⁽¹⁾⁽²⁾

Symbol	Parameter	Min	Max	Unit
$t_{w(NE)}$	FSMC_NE low time	$8 * t_{HCLK} - 1$	$8 * t_{HCLK} + 1$	ns
$t_{w(NOE)}$	FSMC_NWE low time	$5 * t_{HCLK} - 1.5$	$5 * t_{HCLK} + 0.5$	
$t_{su(NWAIT_NE)}$	FSMC_NWAIT valid before FSMC_NEx high	$5 * t_{HCLK} + 1.5$	-	
$t_{h(NE_NWAIT)}$	FSMC_NEx hold time after FSMC_NWAIT invalid	$4 * t_{HCLK} + 1$	-	

1. $C_L = 30$ pF.
2. Based on characterization.

Figure 56. Asynchronous multiplexed PSRAM/NOR write waveforms

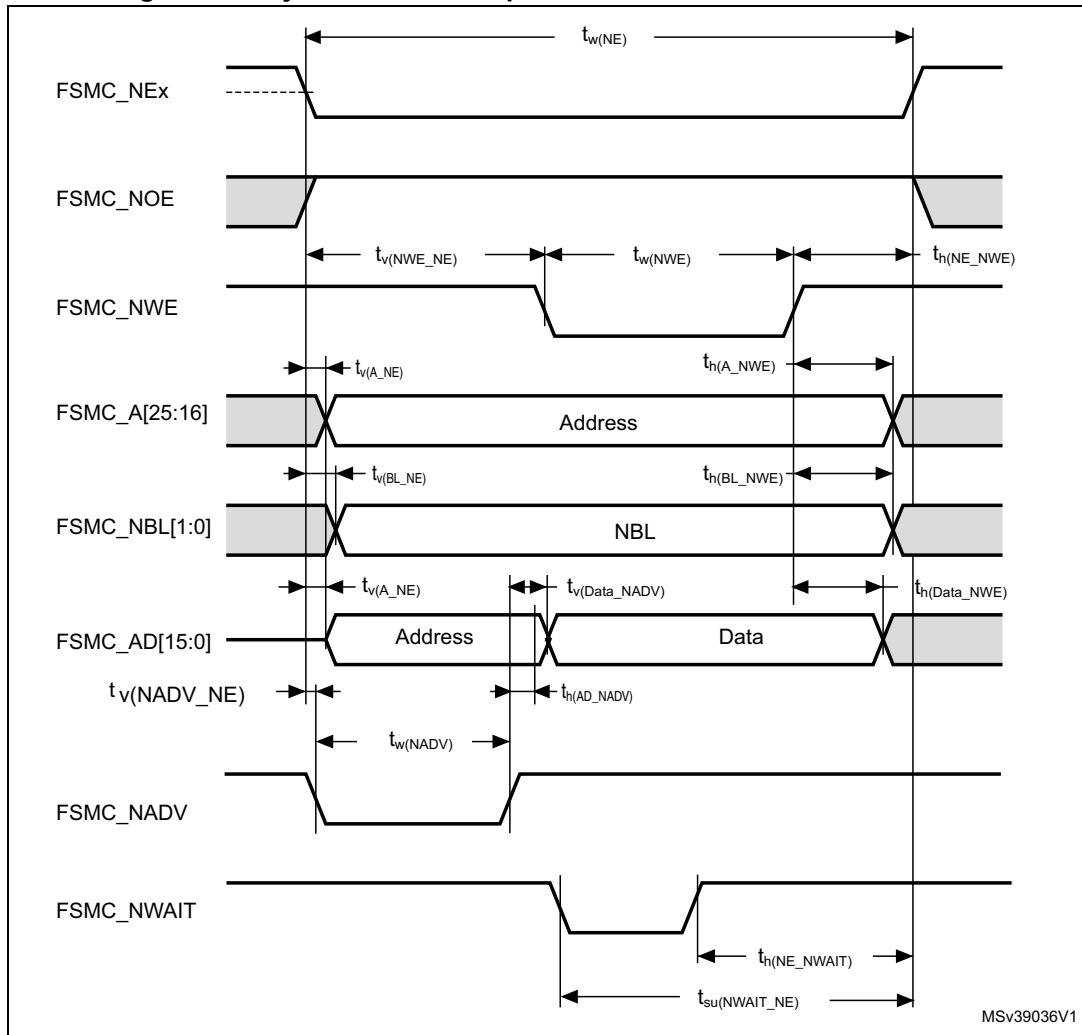

Table 94. Asynchronous multiplexed PSRAM/NOR write timings⁽¹⁾⁽²⁾

Symbol	Parameter	Min	Max	Unit
$t_{w(NE)}$	FSMC_NE low time	$4 * T_{HCLK} - 1$	$4 * T_{HCLK} + 1$	ns
$t_{v(NWE_NE)}$	FSMC_NEx low to FSMC_NWE low	$T_{HCLK} - 1$	$T_{HCLK} + 0.5$	
$t_{w(NWE)}$	FSMC_NWE low time	$2 * T_{HCLK} - 0.5$	$2 * T_{HCLK} - 0.5$	
$t_{h(NE_NWE)}$	FSMC_NWE high to FSMC_NE high hold time	$T_{HCLK} - 0.5$	-	
$t_{v(A_NE)}$	FSMC_NEx low to FSMC_A valid	-	0	
$t_{v(NADV_NE)}$	FSMC_NEx low to FSMC_NADV low	0	0.5	
$t_{w(NADV)}$	FSMC_NADV low time	T_{HCLK}	$T_{HCLK} + 1$	
$t_{h(AD_NADV)}$	FSMC_AD (address) valid hold time after FSMC_NADV high	$T_{HCLK} + 0.5$	-	
$t_{h(A_NWE)}$	Address hold time after FSMC_NWE high	$T_{HCLK} + 0.5$	-	
$t_{h(BL_NWE)}$	FSMC_BL hold time after FSMC_NWE high	$T_{HCLK} - 0.5$	-	
$t_{v(BL_NE)}$	FSMC_NEx low to FSMC_BL valid	-	0.5	
$t_{v(Data_NADV)}$	FSMC_NADV high to Data valid	-	$T_{HCLK} + 2.5$	
$t_{h(Data_NWE)}$	Data hold time after FSMC_NWE high	T_{HCLK}	-	

1. $C_L = 30$ pF.
2. Guaranteed by characterization results.

Table 95. Asynchronous multiplexed PSRAM/NOR write-NWAIT timings⁽¹⁾⁽²⁾

Symbol	Parameter	Min	Max	Unit
$t_{w(NE)}$	FSMC_NE low time	$9 * T_{HCLK} - 1$	$9 * T_{HCLK} + 1$	ns
$t_{w(NWE)}$	FSMC_NWE low time	$7 * T_{HCLK} - 0.5$	$7 * T_{HCLK} + 0.5$	
$t_{su(NWAIT_NE)}$	FSMC_NWAIT valid before FSMC_NEx high	$6 * T_{HCLK} + 2$	-	
$t_{h(NE_NWAIT)}$	FSMC_NEx hold time after FSMC_NWAIT invalid	$4 * T_{HCLK} - 1$	-	

1. $C_L = 30$ pF.
2. Guaranteed by characterization results.

Synchronous waveforms and timings

Figure 57 through Figure 60 represent synchronous waveforms and Table 96 through Table 99 provide the corresponding timings. The results shown in these tables are obtained with the following FSMC configuration:

- BurstAccessMode = FSMC_BurstAccessMode_Enable;
- MemoryType = FSMC_MemoryType_CRAM;
- WriteBurst = FSMC_WriteBurst_Enable;
- CLKDivision = 1; (0 is not supported, see the STM32F446 reference manual: RM0390)
- DataLatency = 1 for NOR Flash; DataLatency = 0 for PSRAM



In all timing tables, the T_{HCLK} is the HCLK clock period (with maximum FSMC_CLK = 90 MHz).

Figure 57. Synchronous multiplexed NOR/PSRAM read timings

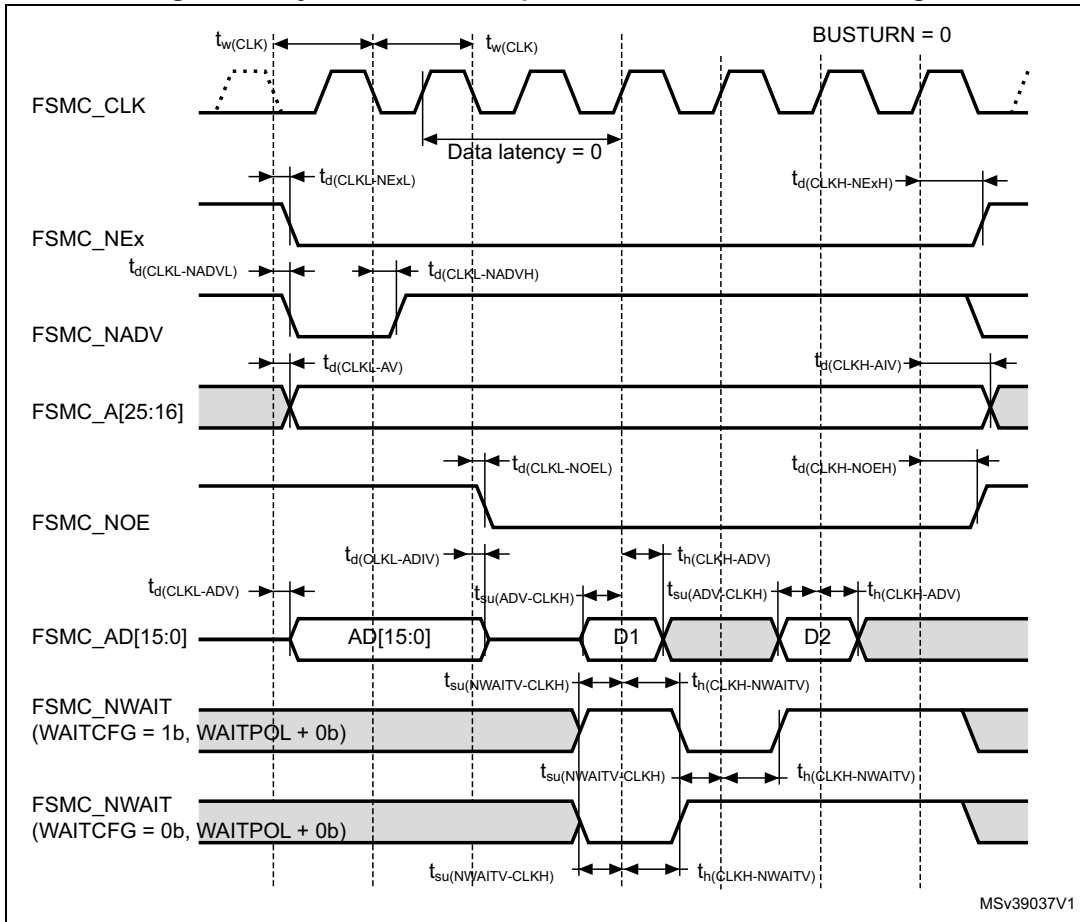

Table 96. Synchronous multiplexed NOR/PSRAM read timings⁽¹⁾⁽²⁾

Symbol	Parameter	Min	Max	Unit
$t_{w(CLK)}$	FSMC_CLK period	$2 * T_{HCLK} - 0.5$	-	ns
$t_{d(CLKL-NExL)}$	FSMC_CLK low to FSMC_NEx low (x=0..2)	-	2	
$t_{d(CLKH-NExH)}$	FSMC_CLK high to FSMC_NEx high (x= 0...2)	$T_{HCLK} + 0.5$	-	
$t_{d(CLKL-NADVl)}$	FSMC_CLK low to FSMC_NADV low	-	1	
$t_{d(CLKL-NADVh)}$	FSMC_CLK low to FSMC_NADV high	0	-	
$t_{d(CLKL-AV)}$	FSMC_CLK low to FSMC_Ax valid (x=16...25)	-	2.5	
$t_{d(CLKH-AIV)}$	FSMC_CLK high to FSMC_Ax invalid (x=16...25)	T_{HCLK}	-	
$t_{d(CLKL-NOEL)}$	FSMC_CLK low to FSMC_NOE low	-	1.5	
$t_{d(CLKH-NOEH)}$	FSMC_CLK high to FSMC_NOE high	$T_{HCLK} - 0.5$	-	
$t_{d(CLKL-ADV)}$	FSMC_CLK low to FSMC_AD[15:0] valid	-	3	
$t_{d(CLKL-ADIV)}$	FSMC_CLK low to FSMC_AD[15:0] invalid	0	-	
$t_{su(ADV-CLKH)}$	FSMC_A/D[15:0] valid data before FSMC_CLK high	1.5	-	
$t_h(CLKH-ADV)$	FSMC_A/D[15:0] valid data after FSMC_CLK high	3.5	-	
$t_{su(NWAIT-CLKH)}$	FSMC_NWAIT valid before FSMC_CLK high	2.5	-	
$t_h(CLKH-NWAIT)$	FSMC_NWAIT valid after FSMC_CLK high	3.5	-	

1. $C_L = 30$ pF.
2. Guaranteed by characterization results.

Figure 58. Synchronous multiplexed PSRAM write timings

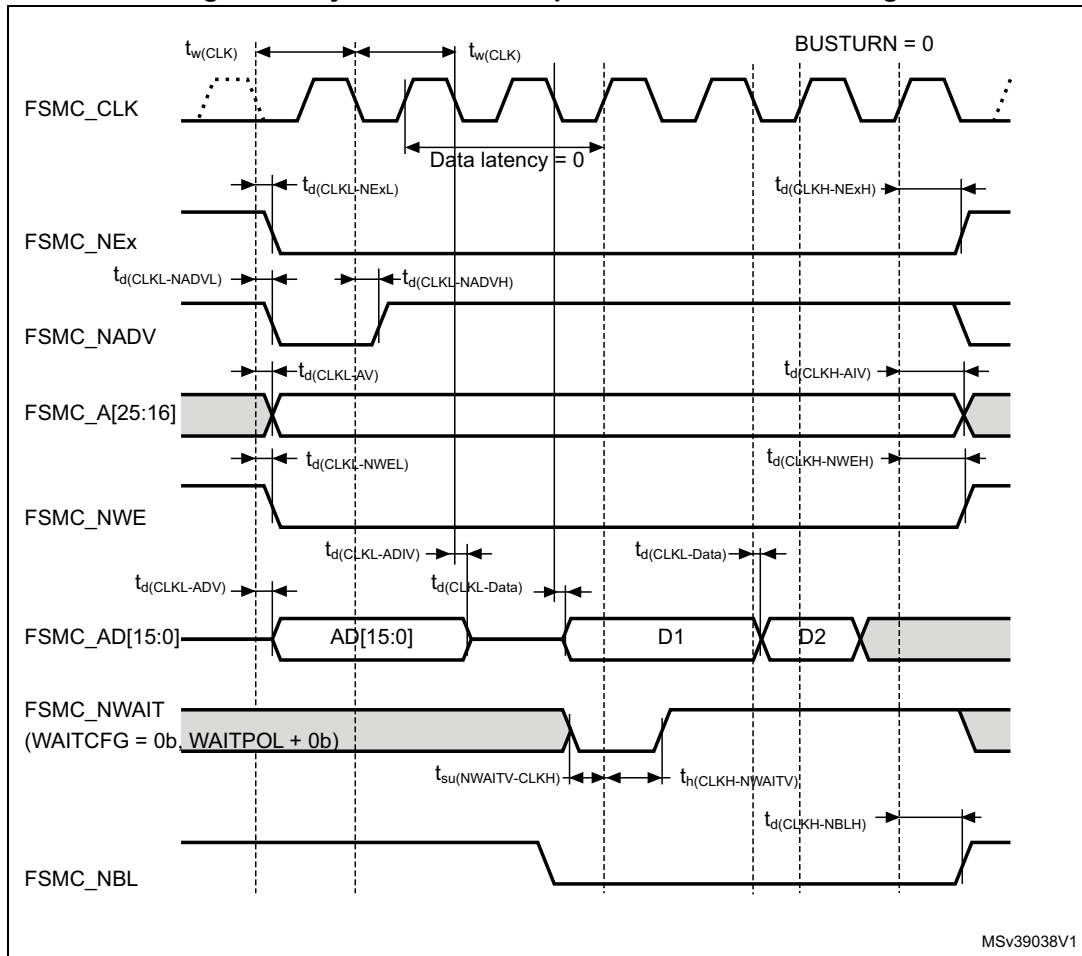

Table 97. Synchronous multiplexed PSRAM write timings⁽¹⁾⁽²⁾

Symbol	Parameter	Min	Max	Unit
$t_{w(CLK)}$	FSMC_CLK period, V_{DD} range= 2.7 to 3.6 V	$2 * T_{HCLK} - 0.5$	-	ns
$t_{d(CLKL-NExL)}$	FSMC_CLK low to FSMC_NEx low ($x= 0...2$)	-	2	
$t_{d(CLKH-NExH)}$	FSMC_CLK high to FSMC_NEx high ($x= 0...2$)	$T_{HCLK} + 0.5$	-	
$t_{d(CLKL-NADV L)}$	FSMC_CLK low to FSMC_NADV low	-	1	
$t_{d(CLKL-NADV H)}$	FSMC_CLK low to FSMC_NADV high	0	-	
$t_{d(CLKL-AV)}$	FSMC_CLK low to FSMC_Ax valid ($x=16...25$)	-	2.5	
$t_{d(CLKH-AIV)}$	FSMC_CLK high to FSMC_Ax invalid ($x=16...25$)	T_{HCLK}	-	
$t_{d(CLKL-NWEL)}$	FSMC_CLK low to FSMC_NWE low	-	1.5	
$t_{d(CLKH-NWEH)}$	FSMC_CLK high to FSMC_NWE high	$T_{HCLK} + 0.5$	-	
$t_{d(CLKL-ADV)}$	FSMC_CLK low to FSMC_AD[15:0] valid	-	3	
$t_{d(CLKL-ADIV)}$	FSMC_CLK low to FSMC_AD[15:0] invalid	0	-	
$t_{d(CLKL-DATA)}$	FSMC_A/D[15:0] valid data after FSMC_CLK low	-	4	
$t_{d(CLKL-NBLL)}$	FSMC_CLK low to FSMC_NBL low	0	2	
$t_{d(CLKH-NBLH)}$	FSMC_CLK high to FSMC_NBL high	$T_{HCLK} + 0.5$	-	
$t_{su(NWAIT-CLKH)}$	FSMC_NWAIT valid before FSMC_CLK high	2	-	
$t_{h(CLKH-NWAIT)}$	FSMC_NWAIT valid after FSMC_CLK high	3.5	-	

1. $C_L = 30$ pF.

2. Guaranteed by characterization results.

Figure 59. Synchronous non-multiplexed NOR/PSRAM read timings

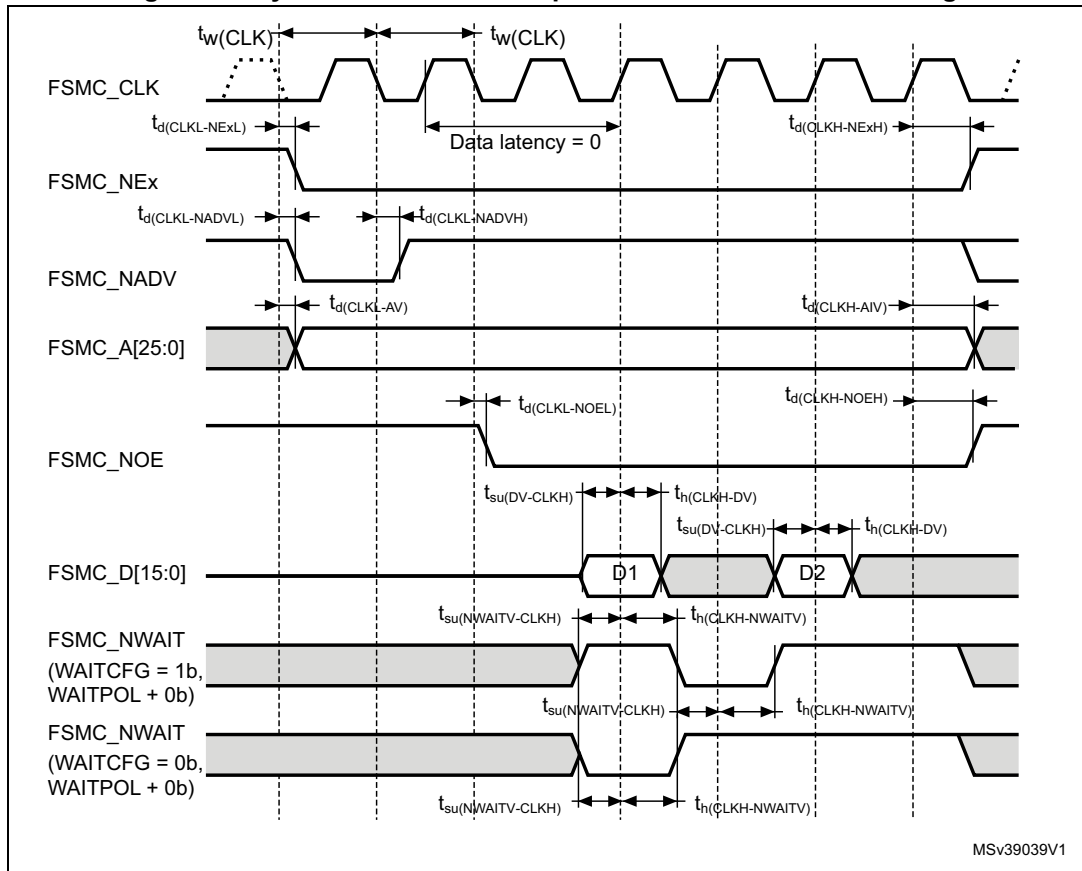

MSv39039V1

Table 98. Synchronous non-multiplexed NOR/PSRAM read timings⁽¹⁾⁽²⁾

Symbol	Parameter	Min	Max	Unit
$t_w(\text{CLK})$	FSMC_CLK period	$2T_{\text{HCLK}} - 0.5$	-	ns
$t_{\text{d}}(\text{CLKL-NExL})$	FSMC_CLK low to FSMC_NEx low ($x=0..2$)	-	2	
$t_{\text{d}}(\text{CLKH-NExH})$	FSMC_CLK high to FSMC_NEx high ($x=0..2$)	$T_{\text{HCLK}} + 0.5$	-	
$t_{\text{d}}(\text{CLKL-NADVl})$	FSMC_CLK low to FSMC_NADV low	-	0.5	
$t_{\text{d}}(\text{CLKL-NADVh})$	FSMC_CLK low to FSMC_NADV high	0	-	
$t_{\text{d}}(\text{CLKL-AV})$	FSMC_CLK low to FSMC_Ax valid ($x=16..25$)	-	2.5	
$t_{\text{d}}(\text{CLKH-AIV})$	FSMC_CLK high to FSMC_Ax invalid ($x=16..25$)	T_{HCLK}	-	
$t_{\text{d}}(\text{CLKL-NOEL})$	FSMC_CLK low to FSMC_NOE low	-	1.5	
$t_{\text{d}}(\text{CLKH-NOEH})$	FSMC_CLK high to FSMC_NOE high	$T_{\text{HCLK}} - 0.5$	-	
$t_{\text{su}}(\text{DV-CLKH})$	FSMC_D[15:0] valid data before FSMC_CLK high	1.5	-	
$t_{\text{h}}(\text{CLKH-DV})$	FSMC_D[15:0] valid data after FSMC_CLK high	3.5	-	
$t_{\text{su}}(\text{NWAIT-CLKH})$	FSMC_NWAIT valid before FSMC_CLK high	2.5	-	
$t_{\text{h}}(\text{CLKH-NWAIT})$	FSMC_NWAIT valid after FSMC_CLK high	3.5	-	

1. $C_L = 30 \text{ pF}$.

2. Guaranteed by characterization results.

Figure 60. Synchronous non-multiplexed PSRAM write timings

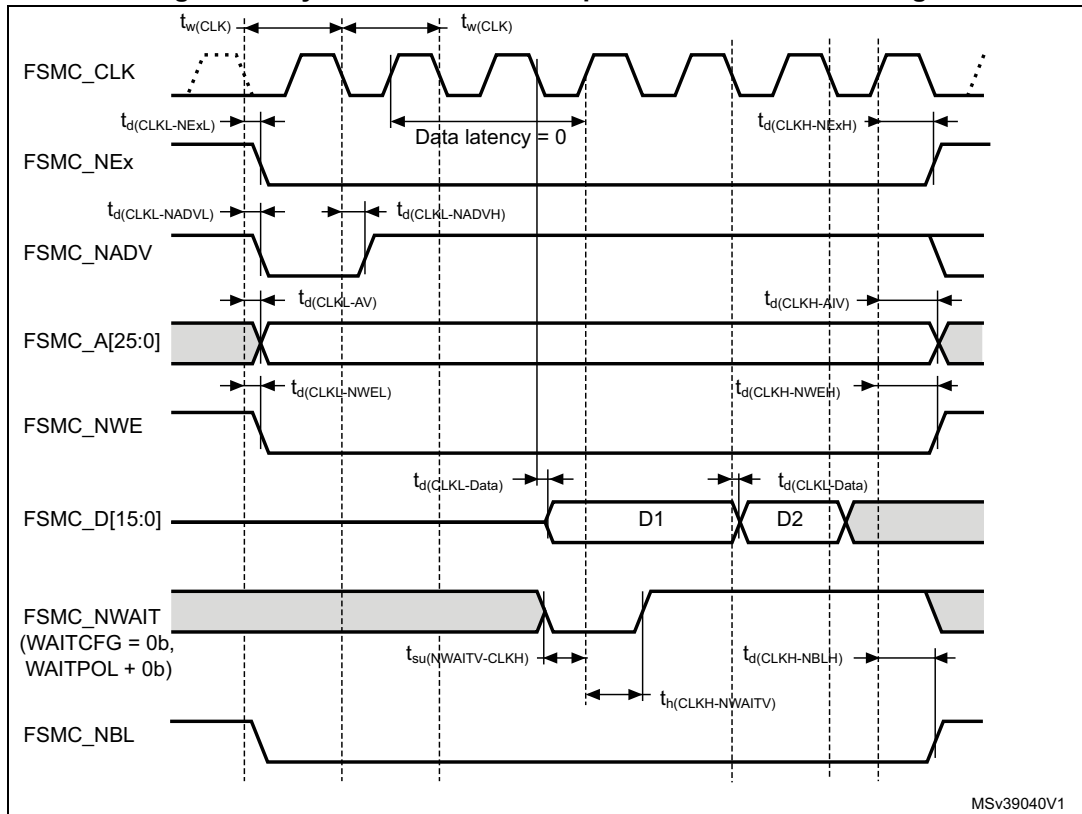

Table 99. Synchronous non-multiplexed PSRAM write timings⁽¹⁾⁽²⁾

Symbol	Parameter	Min	Max	Unit
$t_w(\text{CLK})$	FSMC_CLK period	$2 * T_{\text{HCLK}} - 0.5$	-	ns
$t_d(\text{CLKL-NExL})$	FSMC_CLK low to FSMC_NEx low ($x=0..2$)	-	2	
$t_d(\text{CLKH-NExH})$	FSMC_CLK high to FSMC_NEx high ($x=0..2$)	$T_{\text{HCLK}} + 0.5$	-	
$t_d(\text{CLKL-NADVL})$	FSMC_CLK low to FSMC_NADV low	-	0.5	
$t_d(\text{CLKL-NADVH})$	FSMC_CLK low to FSMC_NADV high	0	-	
$t_d(\text{CLKL-AV})$	FSMC_CLK low to FSMC_Ax valid ($x=16..25$)	-	2.5	
$t_d(\text{CLKH-AIV})$	FSMC_CLK high to FSMC_Ax invalid ($x=16..25$)	T_{HCLK}	-	
$t_d(\text{CLKL-NWEL})$	FSMC_CLK low to FSMC_NWE low	-	1.5	
$t_d(\text{CLKH-NWEH})$	FSMC_CLK high to FSMC_NWE high	$T_{\text{HCLK}} + 1$	-	
$t_d(\text{CLKL-Data})$	FSMC_D[15:0] valid data after FSMC_CLK low	-	4	
$t_d(\text{CLKL-NBLL})$	FSMC_CLK low to FSMC_NBL low	-	2	
$t_d(\text{CLKH-NBLH})$	FSMC_CLK high to FSMC_NBL high	$T_{\text{HCLK}} + 1$	-	
$t_{\text{su}}(\text{NWAIT-CLKH})$	FSMC_NWAIT valid before FSMC_CLK high	2	-	
$t_{\text{h}}(\text{CLKH-NWAIT})$	FSMC_NWAIT valid after FSMC_CLK high	3.5	-	

1. $C_L = 30 \text{ pF}$.
2. Guaranteed by characterization results.

6.3.27 SD/SDIO MMC/eMMC card host interface (SDIO) characteristics

Unless otherwise specified, the parameters given in [Table 100](#) for the SDIO are derived from tests performed under the ambient temperature, f_{PCLK2} frequency and V_{DD} supply voltage conditions summarized in [Table 17](#), with the following configuration:

- Output speed is set to $OSPEEDRy[1:0] = 10$
- Capacitive load $C = 30\text{ pF}$
- Measurement points are done at CMOS levels: $0.5V_{DD}$

Refer to [Section 6.3.16: I/O port characteristics](#) for more details on the input/output characteristics.

Figure 61. SDIO high-speed mode

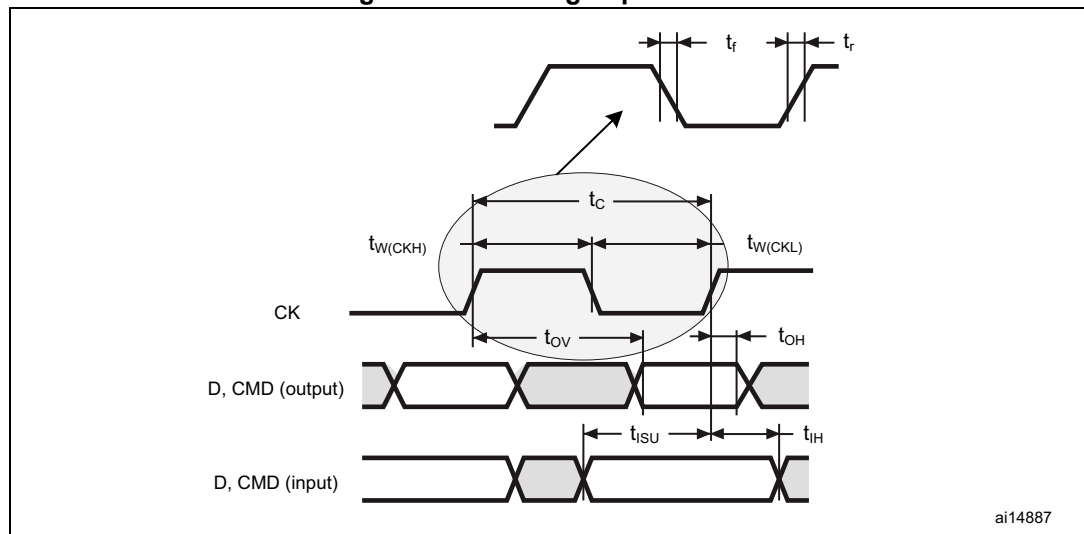

Figure 62. SD default mode

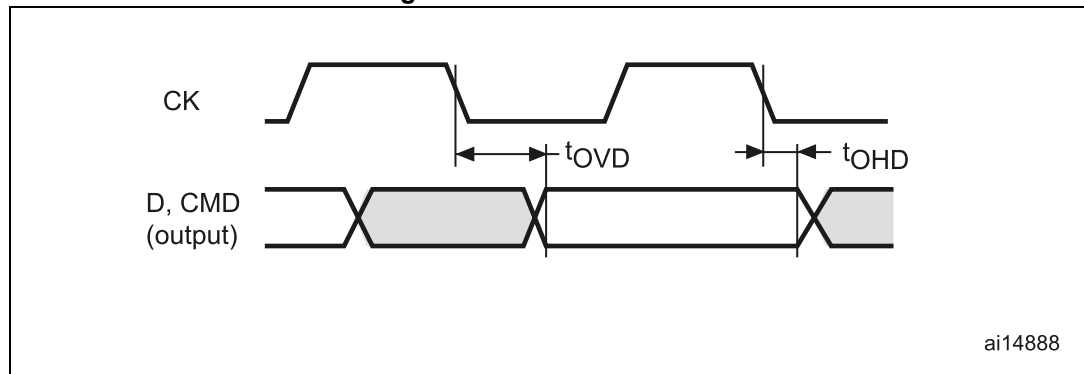

Table 100. SD / MMC characteristics⁽¹⁾⁽²⁾

Symbol	Parameter	Conditions	Min	Typ	Max	Unit
f _{PP}	Clock frequency in data transfer mode	-	0	-	50	MHz
-	SDIO_CK/fPCLK2 frequency ratio	-	-	-	8 / 3	-
t _{W(CKL)}	Clock low time	f _{pp} =50MHz	9.5	10.5	-	ns
t _{W(CKH)}	Clock high time	f _{pp} =50MHz	8.5	9.5	-	
CMD, D inputs (referenced to CK) in MMC and SD HS mode						
t _{ISU}	Input setup time HS	f _{pp} =50MHz	5	-	-	ns
t _{IH}	Input hold time HS	f _{pp} =50MHz	1	-	-	
CMD, D outputs (referenced to CK) in MMC and SD HS mode						
t _{OV}	Output valid time HS	f _{pp} =50MHz	-	12	13.5	ns
t _{OH}	Output hold time HS	f _{pp} =50MHz	10.5	-	-	
CMD, D inputs (referenced to CK) in SD default mode						
t _{ISUD}	Input setup time SD	f _{pp} =25MHz	5	-	-	ns
t _{IHD}	Input hold time SD	f _{pp} =25MHz	1	-	-	
CMD, D outputs (referenced to CK) in SD default mode						
t _{OVD}	Output valid default time SD	f _{pp} =25 MHz	-	2	3	ns
t _{OHD}	Output hold default time SD	f _{pp} =25 MHz	1	-	-	

1. Guaranteed by characterization results.

2. V_{DD} = 2.7 to 3.6 V.

Table 101. eMMC characteristics V_{DD} = 1.7 V to 1.9 V⁽¹⁾⁽²⁾

Symbol	Parameter	Conditions	Min	Typ	Max	Unit
f _{PP}	Clock frequency in data transfer mode	-	0	-	50	MHz
-	SDIO_CK/fPCLK2 frequency ratio	-	-	-	8 / 3	-
t _{W(CKL)}	Clock low time	f _{pp} =50MHz	9.5	10.5	-	ns
t _{W(CKH)}	Clock high time	f _{pp} =50MHz	8.5	9.5	-	
CMD, D inputs (referenced to CK) in eMMC mode						
t _{ISU}	Input setup time HS	f _{pp} =50MHz	3	-	-	ns
t _{IH}	Input hold time HS	f _{pp} =50MHz	2.5	-	-	
CMD, D outputs (referenced to CK) in eMMC mode						
t _{OV}	Output valid time HS	f _{pp} =50MHz	-	15	15.5	ns
t _{OH}	Output hold time HS	f _{pp} =50MHz	13	-	-	

1. Guaranteed by characterization results.

2. C_{LOAD} = 20 pF.

6.3.28 RTC characteristics**Table 102. RTC characteristics**

Symbol	Parameter	Conditions	Min	Max
-	$f_{PCLK1}/RTCCLK$ frequency ratio	Any read/write operation from/to an RTC register	4	-

7 Package information

In order to meet environmental requirements, ST offers these devices in different grades of ECOPACK[®] packages, depending on their level of environmental compliance. ECOPACK[®] specifications, grade definitions and product status are available at: www.st.com. ECOPACK[®] is an ST trademark.

7.1 WLCSP81 package information

Figure 63. WLCSP81 - 81-ball, 4.039 x 3.951 mm, 0.4 mm pitch wafer level chip scale package outline

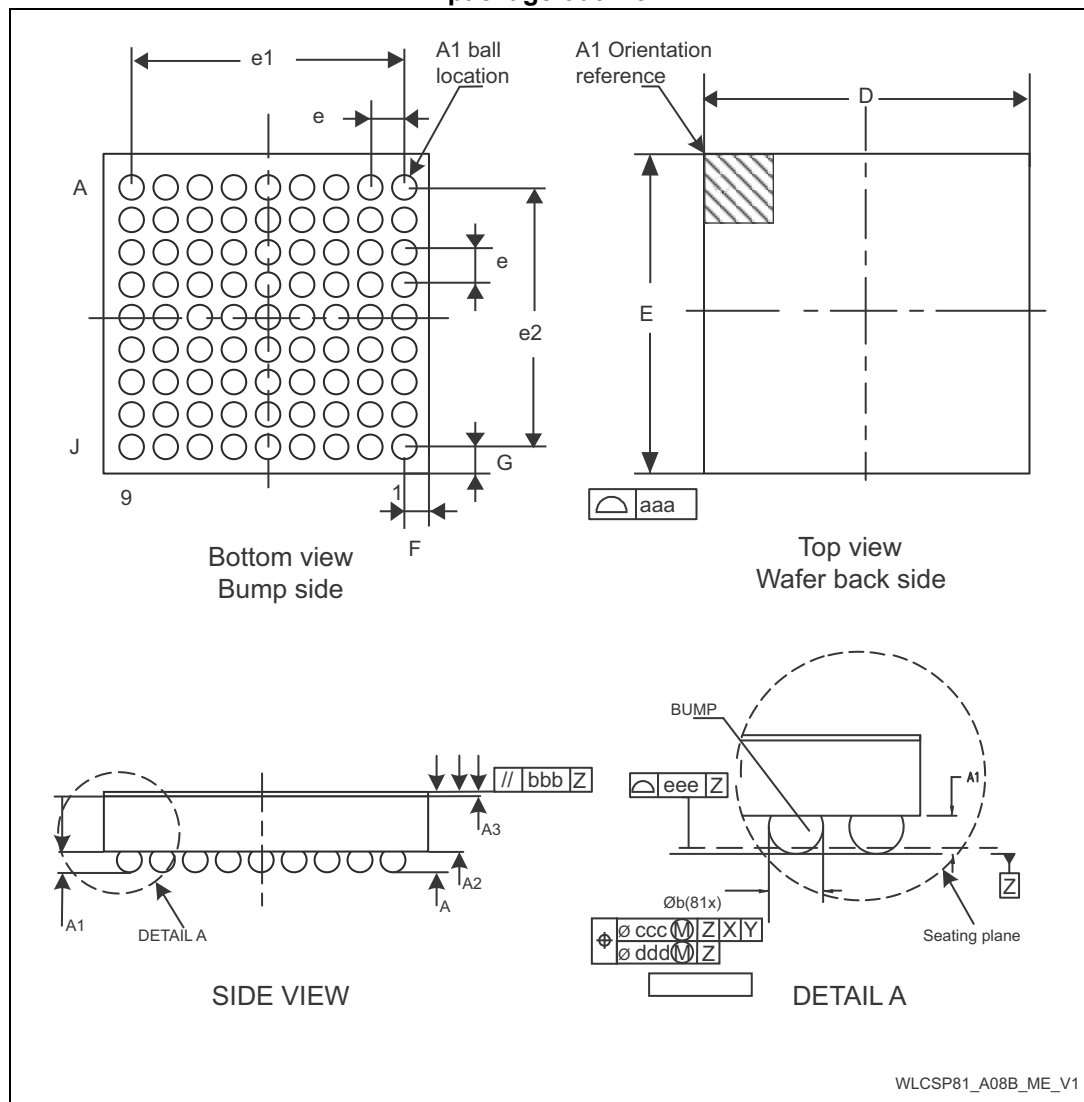

1. Drawing is not to scale.

Table 103. WLCSP81 - 81-ball, 4.039 x 3.951 mm, 0.4 mm pitch wafer level chip scale package mechanical data

Symbol	millimeters			inches ⁽¹⁾		
	Min	Typ	Max	Min	Typ	Max
A	0.525	0.555	0.585	0.0207	0.0219	0.0230
A1	-	0.175	-	-	0.0069	-
A2	-	0.380	-	-	0.0150	-
A3 ⁽²⁾	-	0.025	-	-	0.0010	-
Ø b ⁽³⁾	0.220	0.250	0.280	0.0087	0.0098	0.0110
D	4.004	4.039	4.074	0.1576	0.1590	0.1604
E	3.916	3.951	3.986	0.1542	0.1556	0.1569
e	-	0.400	-	-	0.0157	-
e1	-	3.200	-	-	0.1260	-
e2	-	3.200	-	-	0.1260	-
F	-	0.4195	-	-	0.0165	-
G	-	0.3755	-	-	0.0148	-
aaa	-	-	0.100	-	-	0.0039
bbb	-	-	0.100	-	-	0.0039
ccc	-	-	0.100	-	-	0.0039
ddd	-	-	0.050	-	-	0.0020
eee	-	-	0.050	-	-	0.0020

1. Values in inches are converted from mm and rounded to 4 decimal digits.
2. Back side coating
3. Dimension is measured at the maximum bump diameter parallel to primary datum Z.

Figure 64. WLCSP81- 81-ball, 4.039 x 3.951 mm, 0.4 mm pitch wafer level chip scale package recommended footprint

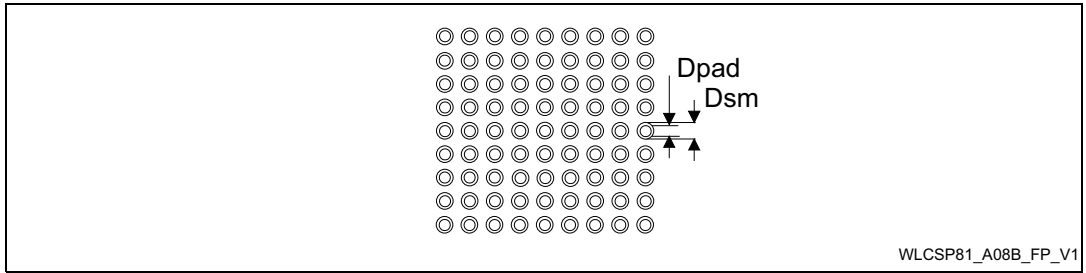

Table 104. WLCSP81 recommended PCB design rules (0.4 mm pitch)

Dimension	Recommended values
Pitch	0.4 mm
Dpad	0.225 mm
Dsm	0.290 mm typ. (depends on the soldermask registration tolerance)
Stencil opening	0.250 mm
Stencil thickness	0.100 mm

Device marking for WLCSP81

The following figure gives an example of topside marking orientation versus pin 1 identifier location.

Other optional marking or inset/upset marks, which identify the parts throughout supply chain operations, are not indicated below.

Figure 65. WLCSP81 marking example (package top view)

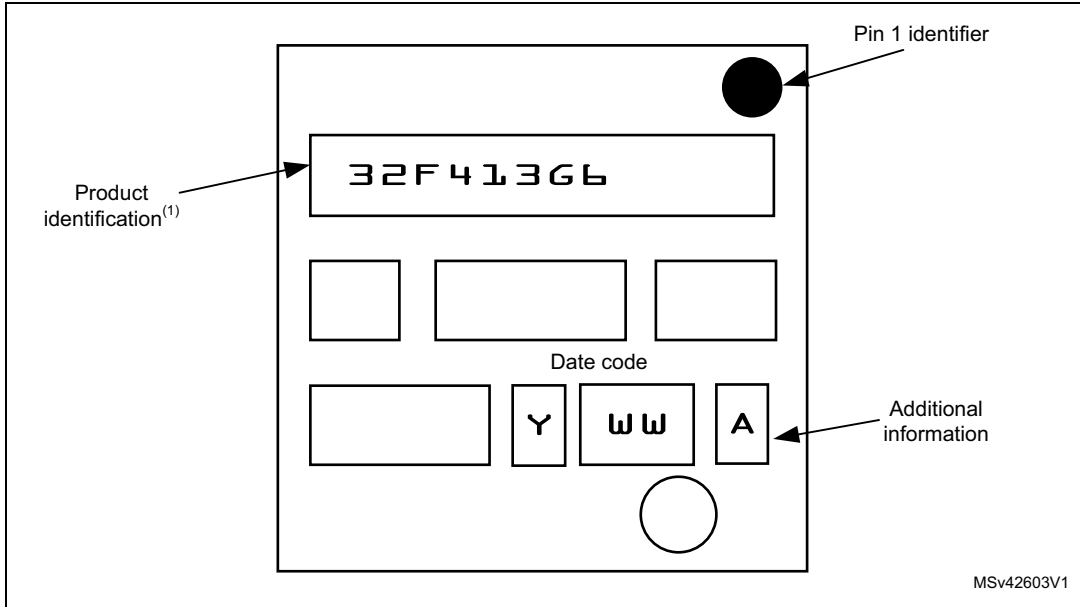

1. Parts marked as ES or E or accompanied by an Engineering Sample notification letter are not yet qualified and therefore not approved for use in production. ST is not responsible for any consequences resulting from such use. In no event will ST be liable for the customer using any of these engineering samples in production. ST's Quality department must be contacted prior to any decision to use these engineering samples to run a qualification activity.

7.2 UFQFPN48 package information

Figure 66. UFQFPN48 - 48-lead, 7x7 mm, 0.5 mm pitch, ultra thin fine pitch quad flat package outline

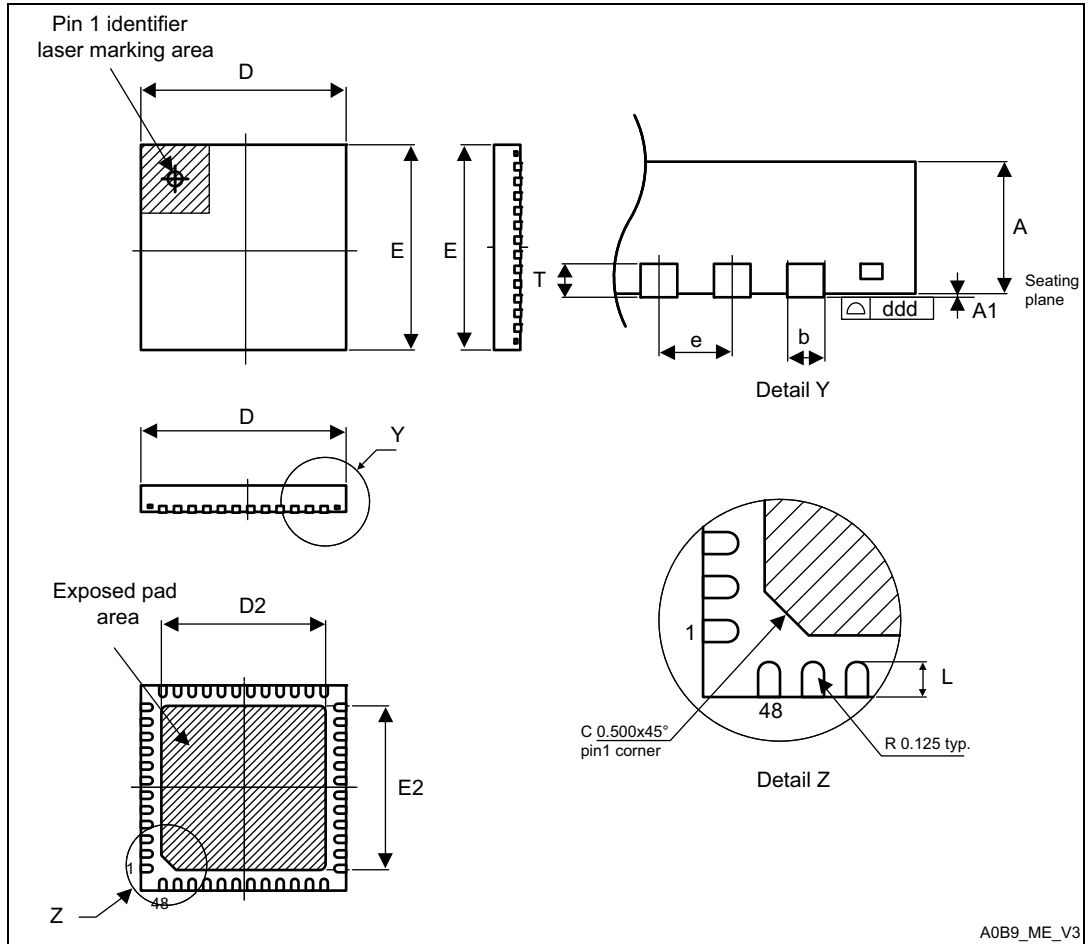

1. Drawing is not to scale.
2. All leads/pads should also be soldered to the PCB to improve the lead/pad solder joint life.
3. There is an exposed die pad on the underside of the UFQFPN package. It is recommended to connect and solder this back-side pad to PCB ground.

Table 105. UFQFPN48 - 48-lead, 7x7 mm, 0.5 mm pitch, ultra thin fine pitch quad flat package mechanical data

Symbol	millimeters			inches ⁽¹⁾		
	Min.	Typ.	Max.	Min.	Typ.	Max.
A	0.500	0.550	0.600	0.0197	0.0217	0.0236
A1	0.000	0.020	0.050	0.0000	0.0008	0.0020
D	6.900	7.000	7.100	0.2717	0.2756	0.2795
E	6.900	7.000	7.100	0.2717	0.2756	0.2795
D2	5.500	5.600	5.700	0.2165	0.2205	0.2244
E2	5.500	5.600	5.700	0.2165	0.2205	0.2244
L	0.300	0.400	0.500	0.0118	0.0157	0.0197
T	-	0.152	-	-	0.0060	-
b	0.200	0.250	0.300	0.0079	0.0098	0.0118
e	-	0.500	-	-	0.0197	-
ddd	-	-	0.080	-	-	0.0031

1. Values in inches are converted from mm and rounded to 4 decimal digits.

Figure 67. UFQFPN48 recommended footprint

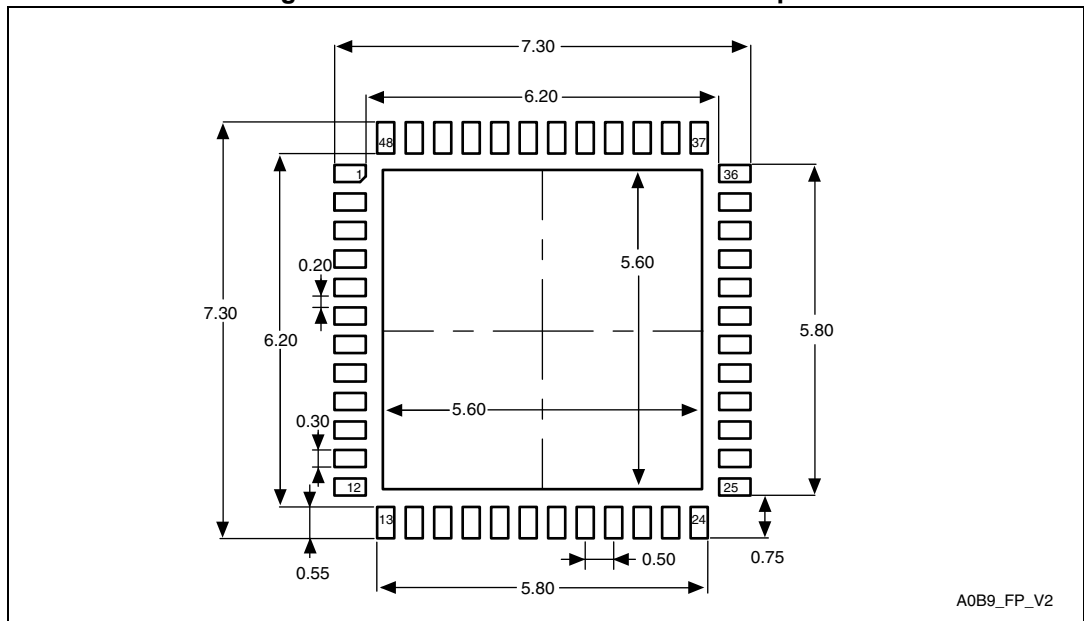

1. Dimensions are in millimeters.

Device marking for UFQFPN48

The following figure gives an example of topside marking orientation versus pin 1 identifier location.

Other optional marking or inset/upset marks, which identify the parts throughout supply chain operations, are not indicated below.

Figure 68. UFQFPN48 marking example (package top view)

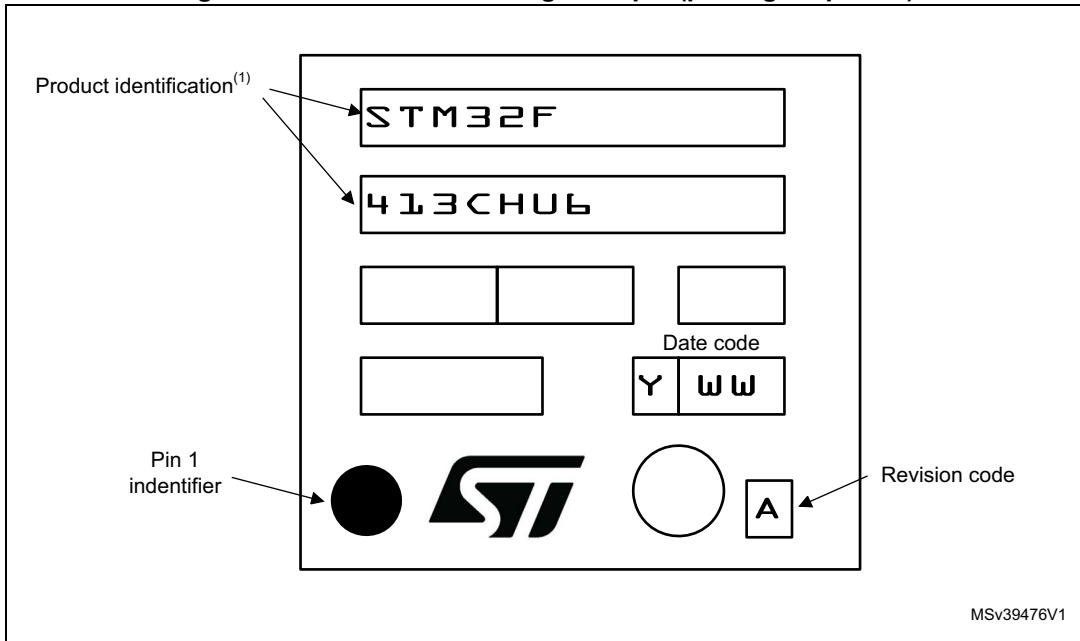

1. Parts marked as ES or E or accompanied by an Engineering Sample notification letter are not yet qualified and therefore not approved for use in production. ST is not responsible for any consequences resulting from such use. In no event will ST be liable for the customer using any of these engineering samples in production. ST's Quality department must be contacted prior to any decision to use these engineering samples to run a qualification activity.

7.3 LQFP64 package information

Figure 69. LQFP64 - 64-pin, 10 x 10 mm low-profile quad flat package outline

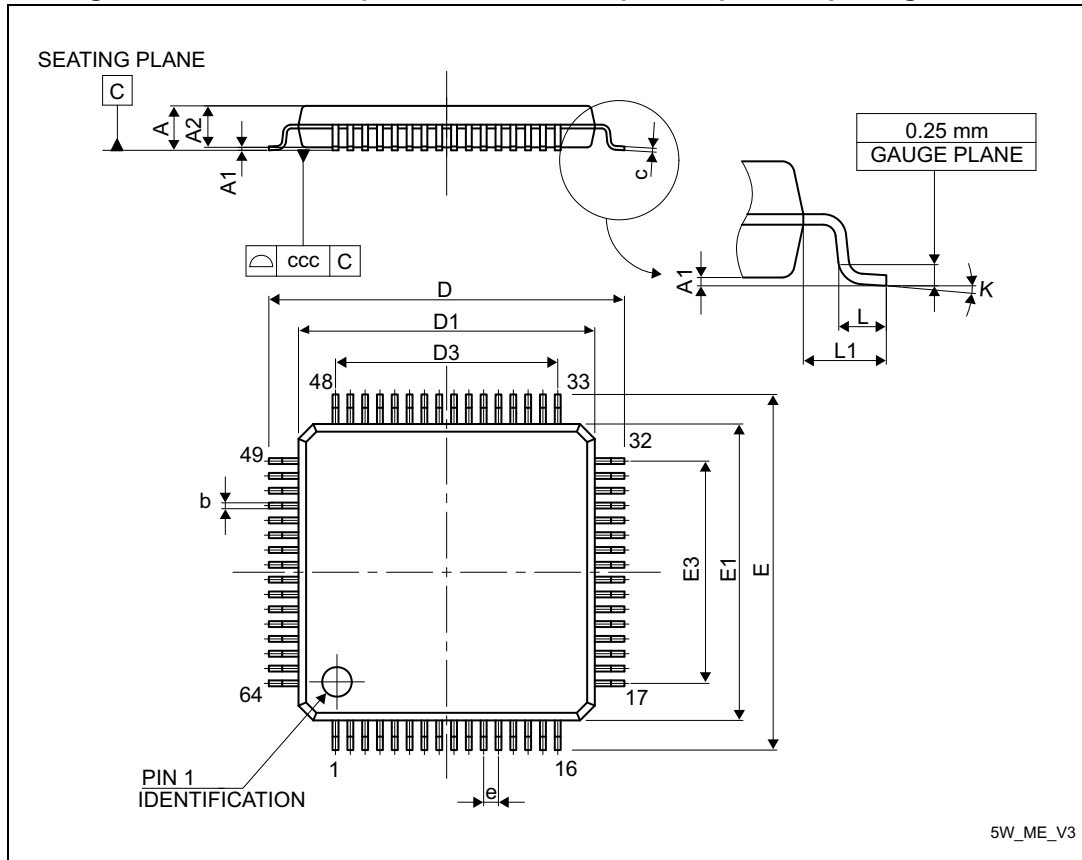

1. Drawing is not to scale.

Table 106. LQFP64 - 64-pin, 10 x 10 mm low-profile quad flat package mechanical data

Symbol	millimeters			inches ⁽¹⁾		
	Min.	Typ.	Max.	Min.	Typ.	Max.
A	-	-	1.600	-	-	0.0630
A1	0.050	-	0.150	0.0020	-	0.0059
A2	1.350	1.400	1.450	0.0531	0.0551	0.0571
b	0.170	0.220	0.270	0.0067	0.0087	0.0106
c	0.090	-	0.200	0.0035	-	0.0079
D	-	12.000	-	-	0.4724	-
D1	-	10.000	-	-	0.3937	-
D3	-	7.500	-	-	0.2953	-
E	-	12.000	-	-	0.4724	-
E1	-	10.000	-	-	0.3937	-
E3	-	7.500	-	-	0.2953	-
e	-	0.500	-	-	0.0197	-
K	0°	3.5°	7°	0°	3.5°	7°
L	0.450	0.600	0.750	0.0177	0.0236	0.0295
L1	-	1.000	-	-	0.0394	-
ccc	-	-	0.080	-	-	0.0031

1. Values in inches are converted from mm and rounded to 4 decimal digits.

Figure 70. LQFP64 recommended footprint

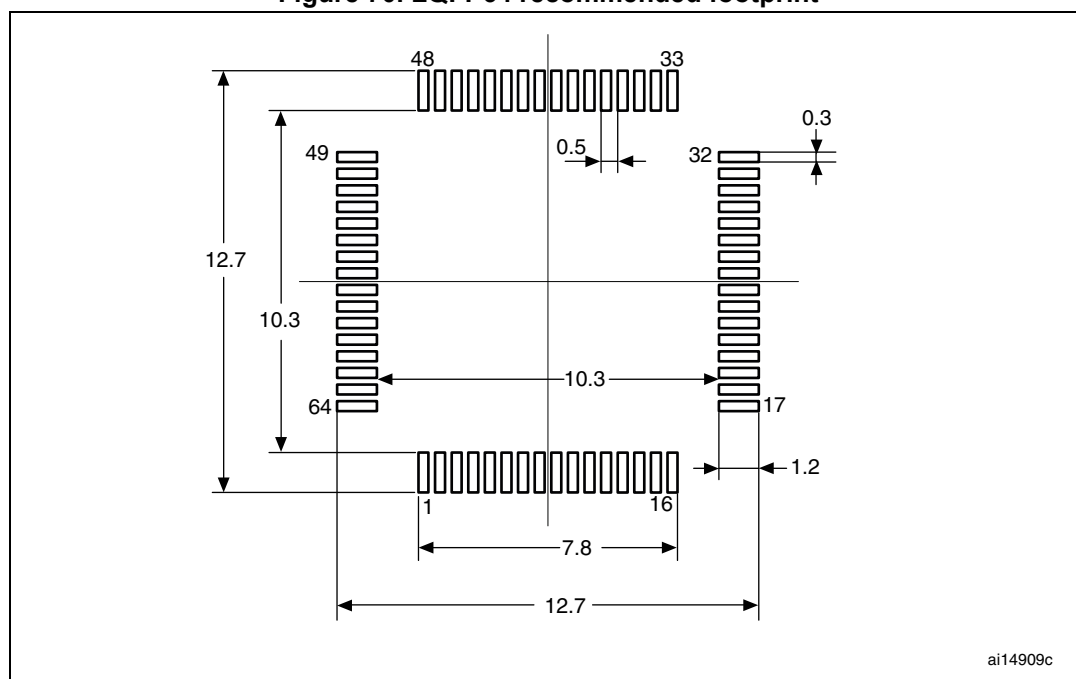

1. Dimensions are in millimeters.

Device marking for LQFP64

The following figure gives an example of topside marking orientation versus pin 1 identifier location.

Other optional marking or inset/upset marks, which identify the parts throughout supply chain operations, are not indicated below.

Figure 71. LQFP64 marking example (package top view)

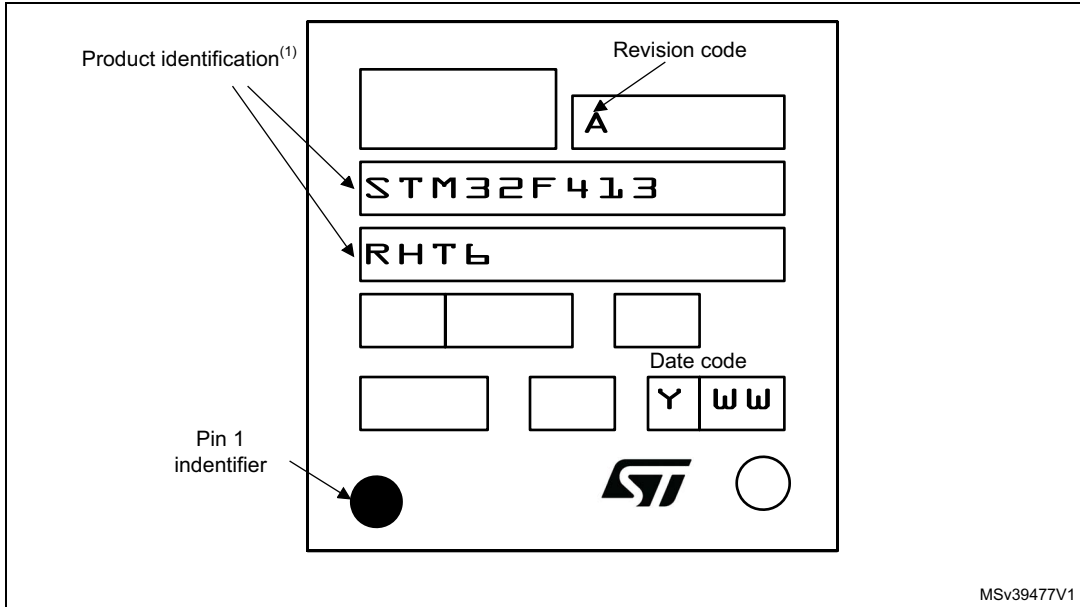

1. Parts marked as ES or E or accompanied by an Engineering Sample notification letter are not yet qualified and therefore not approved for use in production. ST is not responsible for any consequences resulting from such use. In no event will ST be liable for the customer using any of these engineering samples in production. ST's Quality department must be contacted prior to any decision to use these engineering samples to run a qualification activity.

7.4 LQFP100 package information

Figure 72. LQFP100 - 100-pin, 14 x 14 mm low-profile quad flat package outline

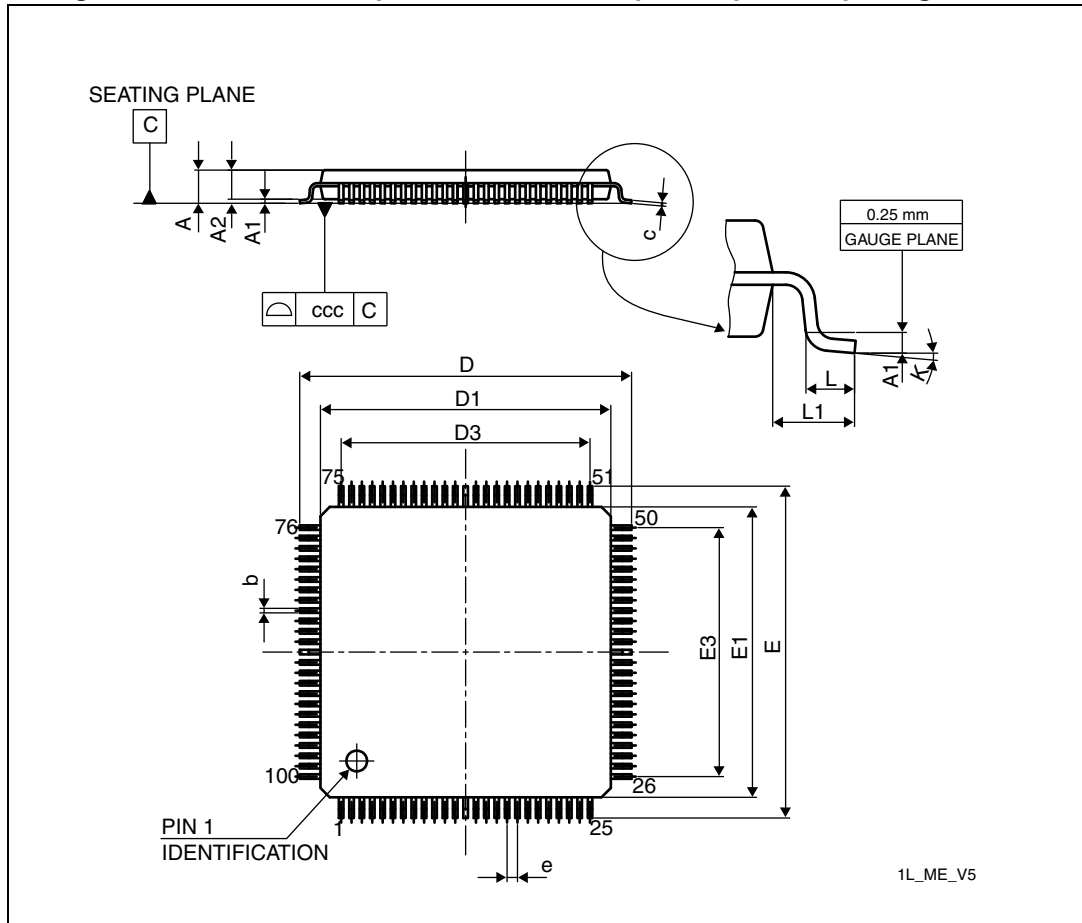

1. Drawing is not to scale. Dimensions are in millimeters.

Table 107. LQFP100 - 100-pin, 14 x 14 mm low-profile quad flat package mechanical data

Symbol	millimeters			inches ⁽¹⁾		
	Min	Typ	Max	Min	Typ	Max
A	-	-	1.600	-	-	0.0630
A1	0.050	-	0.150	0.0020	-	0.0059
A2	1.350	1.400	1.450	0.0531	0.0551	0.0571
b	0.170	0.220	0.270	0.0067	0.0087	0.0106
c	0.090	-	0.200	0.0035	-	0.0079
D	15.800	16.000	16.200	0.6220	0.6299	0.6378
D1	13.800	14.000	14.200	0.5433	0.5512	0.5591
D3	-	12.000	-	-	0.4724	-
E	15.800	16.000	16.200	0.6220	0.6299	0.6378

Table 107. LQPF100 - 100-pin, 14 x 14 mm low-profile quad flat package mechanical data (continued)

Symbol	millimeters			inches ⁽¹⁾		
	Min	Typ	Max	Min	Typ	Max
E1	13.800	14.000	14.200	0.5433	0.5512	0.5591
E3	-	12.000	-	-	0.4724	-
e	-	0.500	-	-	0.0197	-
L	0.450	0.600	0.750	0.0177	0.0236	0.0295
L1	-	1.000	-	-	0.0394	-
k	0.0°	3.5°	7.0°	0.0°	3.5°	7.0°
ccc	-	-	0.080	-	-	0.0031

1. Values in inches are converted from mm and rounded to 4 decimal digits.

Figure 73. LQFP100 - 100-pin, 14 x 14 mm low-profile quad flat recommended footprint

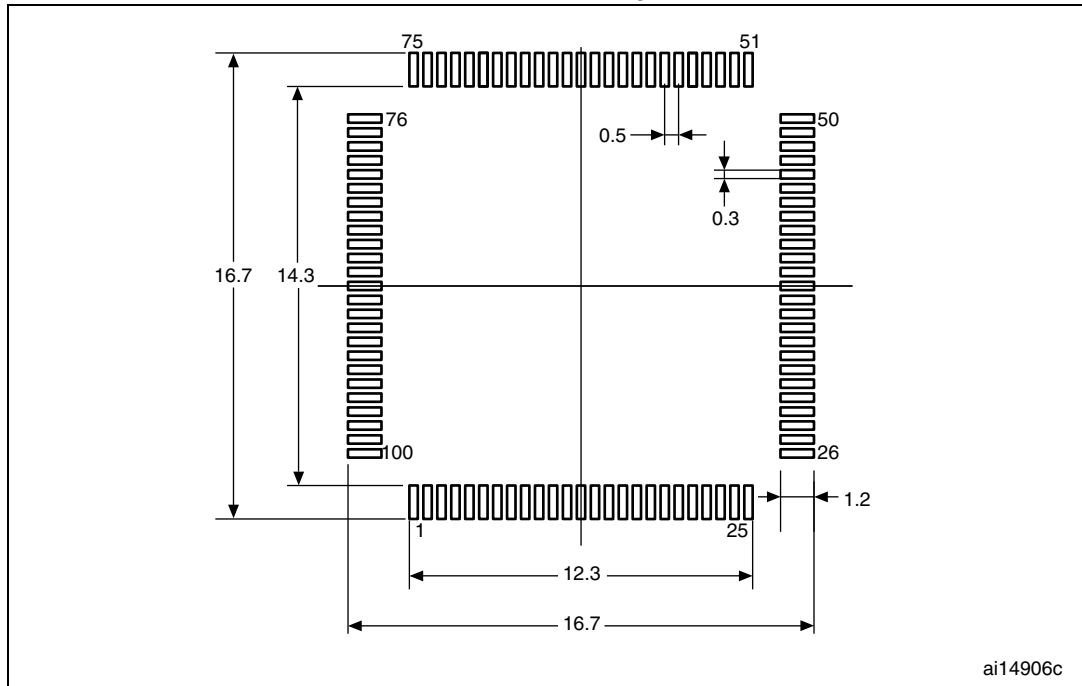

1. Dimensions are in millimeters.

Device marking for LQFP100

The following figure gives an example of topside marking orientation versus pin 1 identifier location.

Other optional marking or inset/upset marks, which identify the parts throughout supply chain operations, are not indicated below.

Figure 74. LQFP100 marking example (package top view)

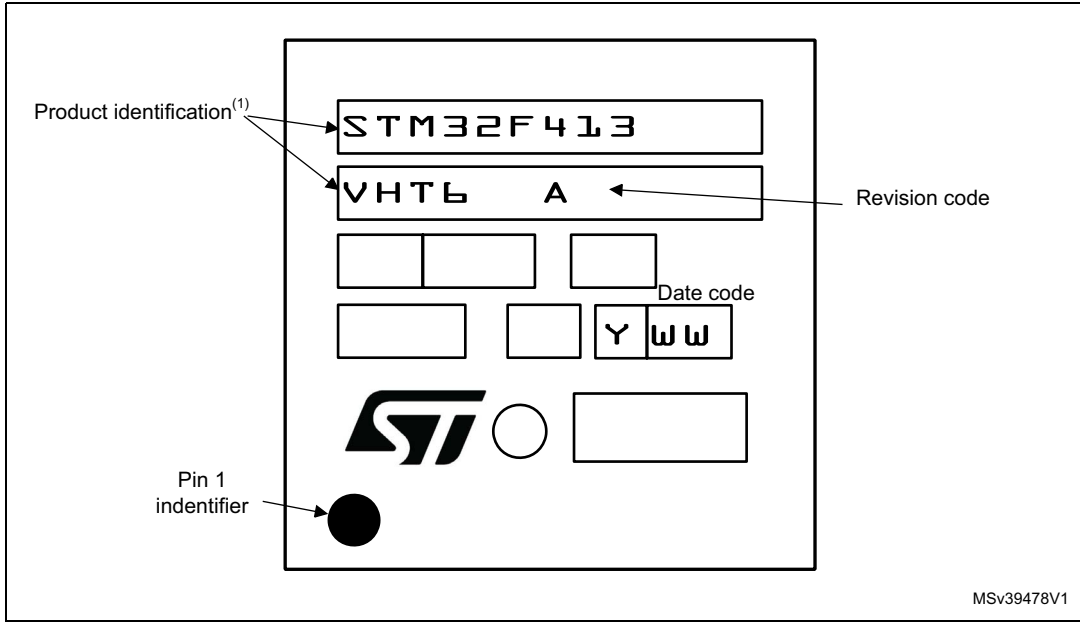

1. Parts marked as ES or E or accompanied by an Engineering Sample notification letter are not yet qualified and therefore not approved for use in production. ST is not responsible for any consequences resulting from such use. In no event will ST be liable for the customer using any of these engineering samples in production. ST's Quality department must be contacted prior to any decision to use these engineering samples to run a qualification activity.

7.5 LQFP144 package information

Figure 75. LQFP144 - 144-pin, 20 x 20 mm low-profile quad flat package outline

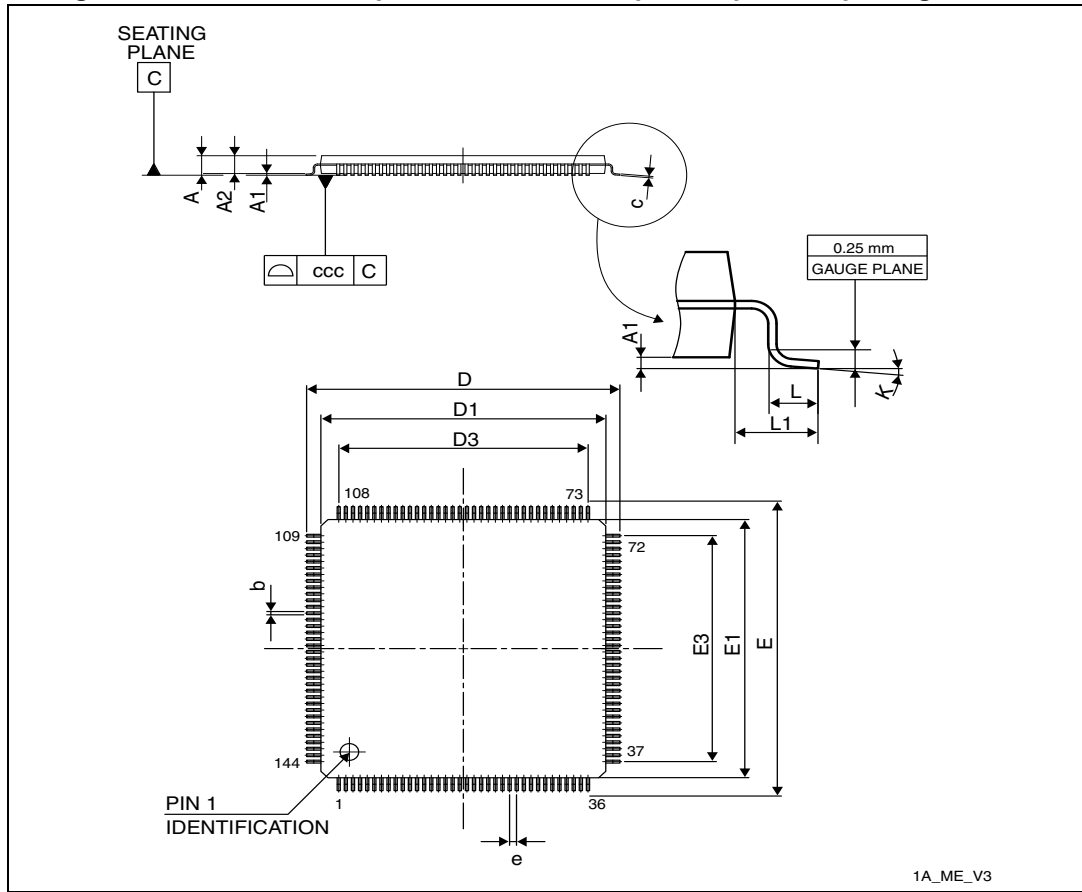

1. Drawing is not to scale.

Table 108. LQFP144 - 144-pin, 20 x 20 mm low-profile quad flat package mechanical data

Symbol	millimeters			inches ⁽¹⁾		
	Min	Typ	Max	Min	Typ	Max
A	-	-	1.600	-	-	0.0630
A1	0.050	-	0.150	0.0020	-	0.0059
A2	1.350	1.400	1.450	0.0531	0.0551	0.0571
b	0.170	0.220	0.270	0.0067	0.0087	0.0106
c	0.090	-	0.200	0.0035	-	0.0079
D	21.800	22.000	22.200	0.8583	0.8661	0.8740
D1	19.800	20.000	20.200	0.7795	0.7874	0.7953
D3	-	17.500	-	-	0.6890	-
E	21.800	22.000	22.200	0.8583	0.8661	0.8740
E1	19.800	20.000	20.200	0.7795	0.7874	0.7953
E3	-	17.500	-	-	0.6890	-
e	-	0.500	-	-	0.0197	-
L	0.450	0.600	0.750	0.0177	0.0236	0.0295
L1	-	1.000	-	-	0.0394	-
k	0°	3.5°	7°	0°	3.5°	7°
ccc	-	-	0.080	-	-	0.0031

1. Values in inches are converted from mm and rounded to 4 decimal digits.

Figure 76. LQFP144 - 144-pin, 20 x 20 mm low-profile quad flat package recommended footprint

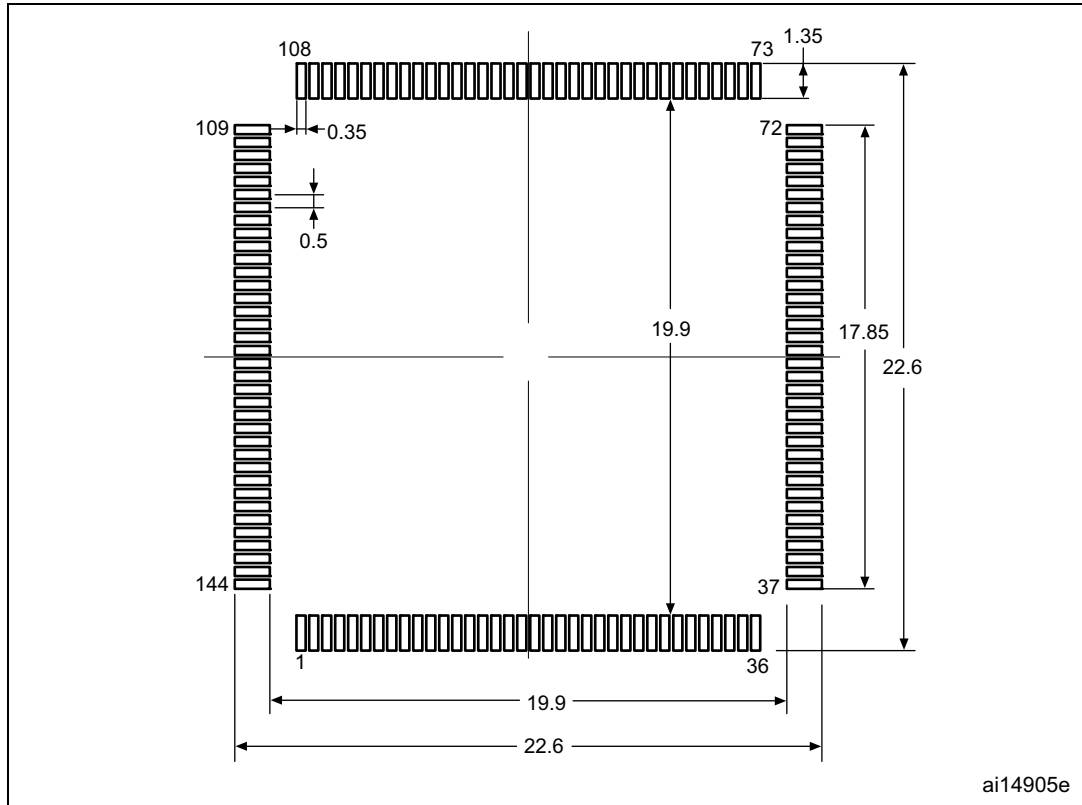

1. Dimensions are expressed in millimeters.

Device marking for LQFP144

The following figure gives an example of topside marking orientation versus pin 1 identifier location.

Other optional marking or inset/upset marks, which identify the parts throughout supply chain operations, are not indicated below.

Figure 77. LQFP144 marking example (package top view)

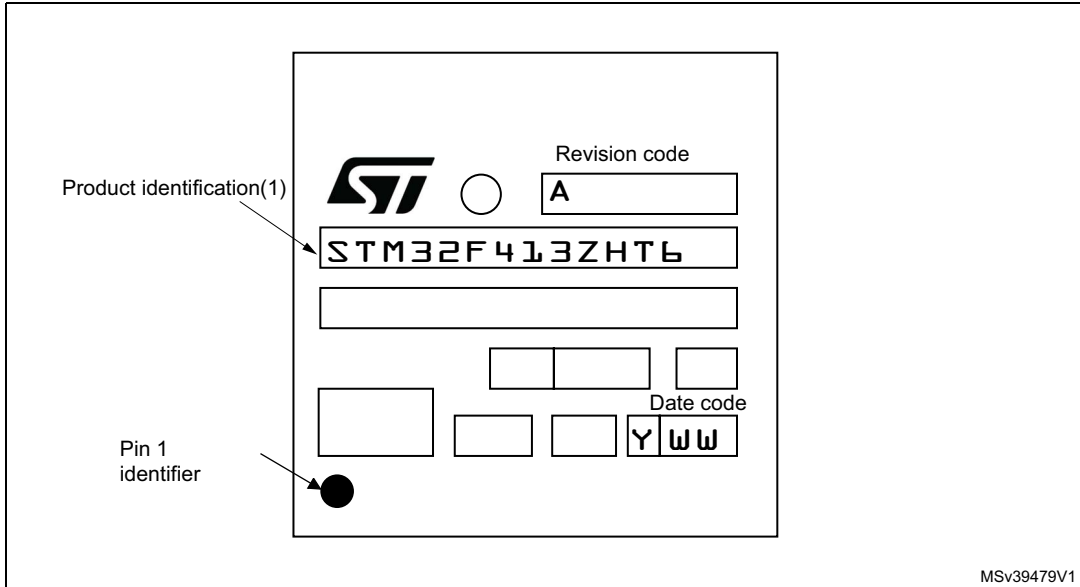

1. Parts marked as ES or E or accompanied by an Engineering Sample notification letter are not yet qualified and therefore not approved for use in production. ST is not responsible for any consequences resulting from such use. In no event will ST be liable for the customer using any of these engineering samples in production. ST's Quality department must be contacted prior to any decision to use these engineering samples to run a qualification activity.

7.6 UFBGA100 package information

Figure 78. UFBGA100 - 100-pin, 7 x 7 mm, 0.50 mm pitch, ultra fine pitch ball grid array package outline

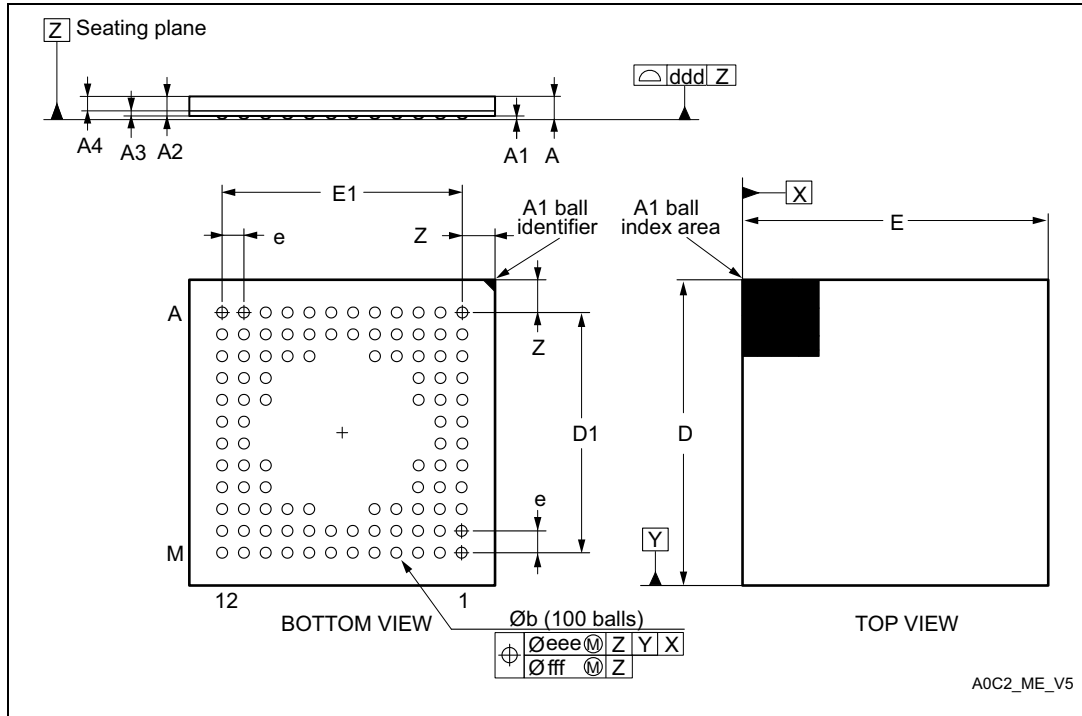

1. Drawing is not to scale.

Table 109. UFBGA100 - 100-ball, 7 x 7 mm, 0.50 mm pitch, ultra fine pitch ball grid array package mechanical data

Symbol	millimeters			inches ⁽¹⁾		
	Min.	Typ.	Max.	Min.	Typ.	Max.
A	-	-	0.600	-	-	0.0236
A1	-	-	0.110	-	-	0.0043
A2	-	0.450	-	-	0.0177	-
A3	-	0.130	-	-	0.0051	0.0094
A4	-	0.320	-	-	0.0126	-
b	0.240	0.290	0.340	0.0094	0.0114	0.0134
D	6.850	7.000	7.150	0.2697	0.2756	0.2815
D1	-	5.500	-	-	0.2165	-
E	6.850	7.000	7.150	0.2697	0.2756	0.2815
E1	-	5.500	-	-	0.2165	-
e	-	0.500	-	-	0.0197	-
Z	-	0.750	-	-	0.0295	-

Table 109. UFBGA100 - 100-ball, 7 x 7 mm, 0.50 mm pitch, ultra fine pitch ball grid array package mechanical data (continued)

Symbol	millimeters			inches ⁽¹⁾		
	Min.	Typ.	Max.	Min.	Typ.	Max.
ddd	-	-	0.080	-	-	0.0031
eee	-	-	0.150	-	-	0.0059
fff	-	-	0.050	-	-	0.0020

1. Values in inches are converted from mm and rounded to 4 decimal digits.

Figure 79. UFBGA100 - 100-pin, 7 x 7 mm, 0.50 mm pitch, ultra fine pitch ball grid array package recommended footprint

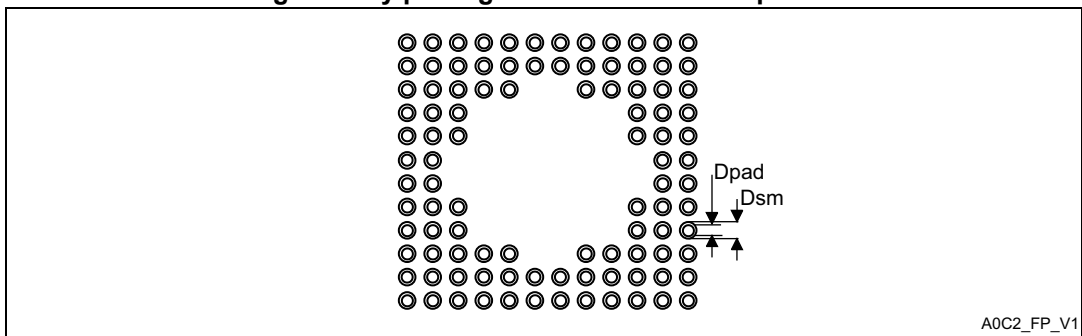

Table 110. UFBGA100 recommended PCB design rules (0.5 mm pitch BGA)

Dimension	Recommended values
Pitch	0.5
Dpad	0.280 mm
Dsm	0.370 mm typ. (depends on the soldermask registration tolerance)
Stencil opening	0.280 mm
Stencil thickness	Between 0.100 mm and 0.125 mm

Device marking for UFBGA100

The following figure gives an example of topside marking orientation versus ball A1 identifier location.

Other optional marking or inset/upset marks, which identify the parts throughout supply chain operations, are not indicated below.

Figure 80. UFBGA100 marking example (package top view)

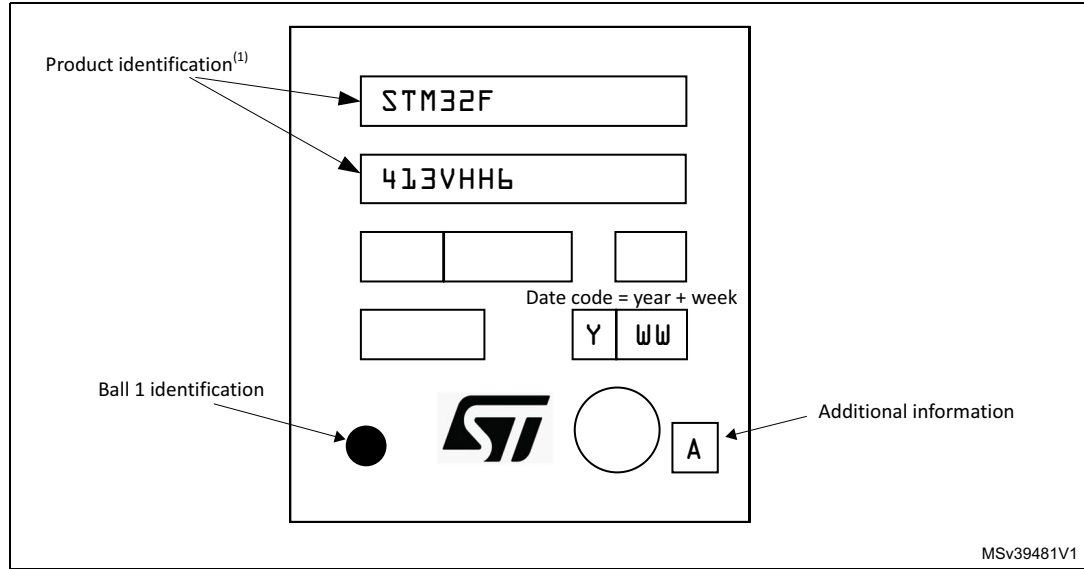

1. Parts marked as ES or E or accompanied by an Engineering Sample notification letter are not yet qualified and therefore not approved for use in production. ST is not responsible for any consequences resulting from such use. In no event will ST be liable for the customer using any of these engineering samples in production. ST's Quality department must be contacted prior to any decision to use these engineering samples to run a qualification activity.

7.7 UFBGA144 package information

Figure 81. UFBGA144 - 144-pin, 10 x 10 mm, 0.80 mm pitch, ultra fine pitch ball grid array package outline

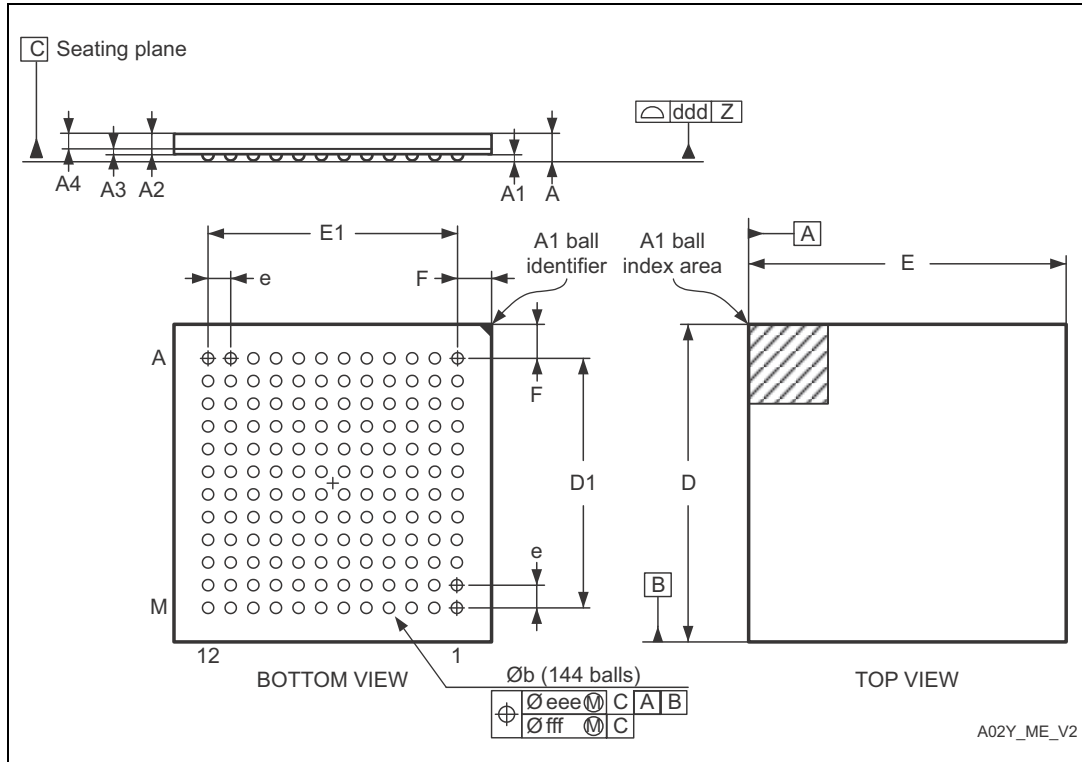

1. Drawing is not to scale.

Table 111. UFBGA144 - 144-ball, 10 x 10 mm, 0.80 mm pitch, ultra fine pitch ball grid array package mechanical data

Symbol	millimeters			inches ⁽¹⁾		
	Min.	Typ.	Max.	Min.	Typ.	Max.
A	0.460	0.530	0.600	0.0181	0.0209	0.0236
A1	0.050	0.080	0.110	0.0020	0.0031	0.0043
A2	0.400	0.450	0.500	0.0157	0.0177	0.0197
A3	-	0.130	-	-	0.0051	-
A4	-	0.320	-	-	0.0126	-
b	0.360	0.400	0.440	0.0091	0.0110	0.0130
D	9.950	10.000	10.050	0.2736	0.2756	0.2776
D1	8.750	8.800	8.850	0.2343	0.2362	0.2382
E	9.950	10.000	10.050	0.2736	0.2756	0.2776
E1	8.750	8.800	8.850	0.2343	0.2362	0.2382
e	0.750	0.800	0.850	-	0.0197	-

Table 111. UFBGA144 - 144-ball, 10 x 10 mm, 0.80 mm pitch, ultra fine pitch ball grid array package mechanical data (continued)

Symbol	millimeters			inches ⁽¹⁾		
	Min.	Typ.	Max.	Min.	Typ.	Max.
F	0.550	0.600	0.650	0.0177	0.0197	0.0217
ddd	-	-	0.080	-	-	0.0039
eee	-	-	0.150	-	-	0.0059
fff	-	-	0.080	-	-	0.0020

1. Values in inches are converted from mm and rounded to 4 decimal digits.

Figure 82. UFBGA144 - 144-pin, 10 x 10 mm, 0.80 mm pitch, ultra fine pitch ball grid array recommended footprint

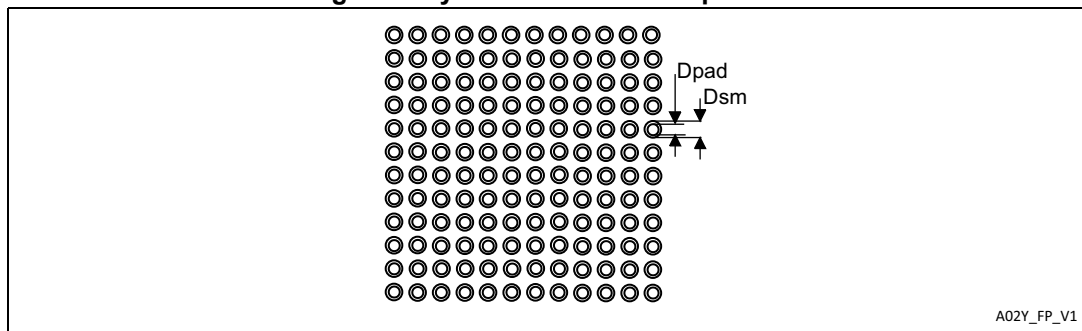

Table 112. UFBGA144 recommended PCB design rules (0.80 mm pitch BGA)

Dimension	Recommended values
Pitch	0.80 mm
Dpad	0.400 mm
Dsm	0.550 mm typ. (depends on the soldermask registration tolerance)

Note: Non solder mask defined (NSMD) pads are recommended.
 4 to 6 mils solder paste screen printing process.
 Stencil opening is 0.400 mm.
 Stencil thickness is between 0.100 mm and 0.125 mm.
 Pad trace width is 0.120 mm.

Device marking for UFBGA144

The following figure gives an example of topside marking orientation versus ball A1 identifier location.

Other optional marking or inset/upset marks, which identify the parts throughout supply chain operations, are not indicated below.

Figure 83. UFBGA144 marking example (package top view)

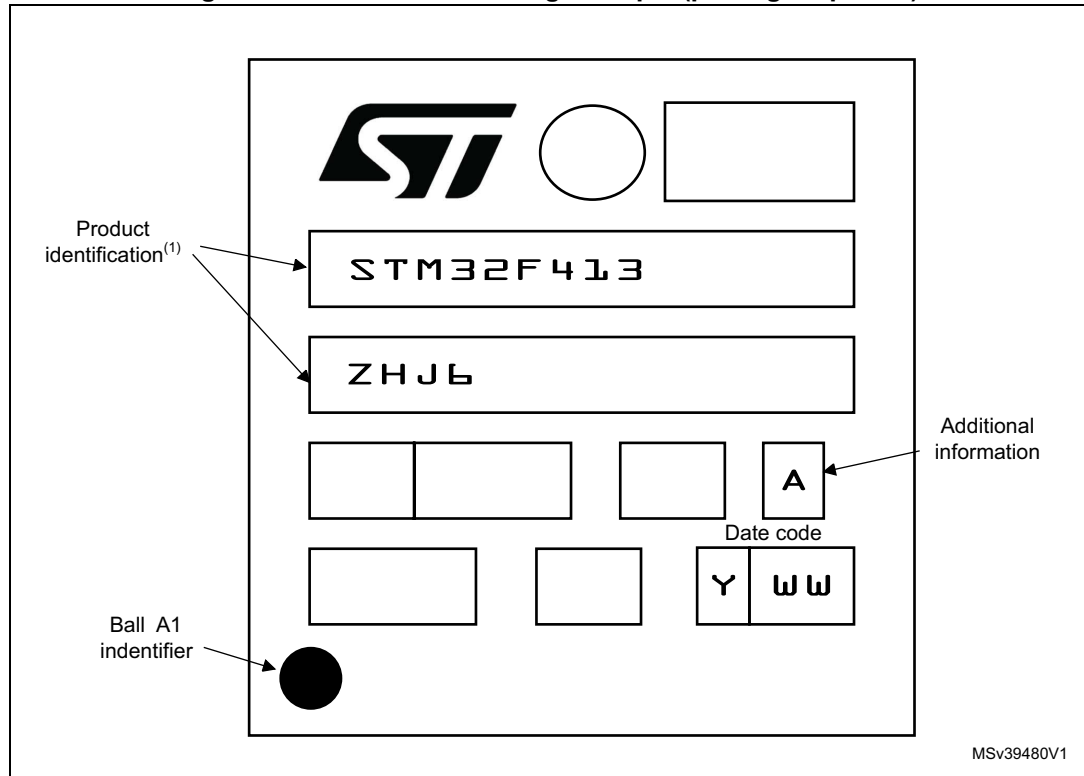

1. Parts marked as ES or E or accompanied by an Engineering Sample notification letter are not yet qualified and therefore not approved for use in production. ST is not responsible for any consequences resulting from such use. In no event will ST be liable for the customer using any of these engineering samples in production. ST's Quality department must be contacted prior to any decision to use these engineering samples to run a qualification activity.

7.8 Thermal characteristics

The maximum chip junction temperature (T_{Jmax}) must never exceed the values given in [Table 17: General operating conditions](#).

The maximum chip-junction temperature, T_J max., in degrees Celsius, may be calculated using the following equation:

$$T_J \text{ max} = T_A \text{ max} + (PD \text{ max} \times \Theta_{JA})$$

Where:

- T_A max is the maximum ambient temperature in °C,
- Θ_{JA} is the package junction-to-ambient thermal resistance, in °C/W,
- PD max is the sum of P_{INT} max and $P_{I/O}$ max ($PD \text{ max} = P_{INT} \text{ max} + P_{I/O} \text{ max}$),
- P_{INT} max is the product of I_{DD} and V_{DD} , expressed in Watts. This is the maximum chip internal power.

$P_{I/O}$ max represents the maximum power dissipation on output pins where:

$$P_{I/O} \text{ max} = \Sigma (V_{OL} \times I_{OL}) + \Sigma (V_{DD} - V_{OH}) \times I_{OH},$$

taking into account the actual V_{OL} / I_{OL} and V_{OH} / I_{OH} of the I/Os at low and high level in the application.

Table 113. Package thermal characteristics

Symbol	Parameter	Value	Unit
Θ_{JA}	Thermal resistance junction-ambient LQFP144 - 20 x 20 mm	35	°C/W
	Thermal resistance junction-ambient LQFP100 - 14 x 14 mm	43	
	Thermal resistance junction-ambient LQFP64 - 10 x 10 mm	47	
	Thermal resistance junction-ambient UFBGA144 - 10 x 10 mm / 0.8 mm pitch	48	
	Thermal resistance junction-ambient UFBGA100 - 7 x 7 mm	57	
	Thermal resistance junction-ambient WLCSP81 - 4.039 x 3.951 mm	39.7	
	Thermal resistance junction-ambient UFQFPN48 - 7 x 7 mm	32	

7.8.1 Reference document

JESD51-2 Integrated Circuits Thermal Test Method Environment Conditions - Natural Convection (Still Air). Available from www.jedec.org.

8 Ordering information

Table 114. Ordering information scheme

Example:	STM32	F	413	C	H	T	6	TR
Device family								
STM32 = Arm [®] -based 32-bit microcontroller								
Product type								
F = General-purpose								
Device subfamily								
413 = 413 line								
Pin count								
C = 48 pins								
R = 64 pins								
M = 81 pins								
V = 100 pins								
Z = 144 pins								
Flash memory size								
G = 1024 Kbytes of Flash memory								
H = 1536 Kbytes of Flash memory								
Package								
H = UFBGA 7 x 7 mm								
J = UFBGA 10 x 10 mm								
T = LQFP								
U = UFQFPN								
Y = WLCSP								
Temperature range								
6 = Industrial temperature range, – 40 to 85 °C								
3 = Industrial temperature range, – 40 to 125 °C								
Packing								
TR = tape and reel								
No character = tray or tube								

Appendix A **Recommendations when using the internal reset OFF**

When the internal reset is OFF, the following integrated features are no longer supported:

- The integrated power-on-reset (POR)/power-down reset (PDR) circuitry is disabled.
- The brownout reset (BOR) circuitry must be disabled. By default BOR is OFF.
- The embedded programmable voltage detector (PVD) is disabled.
- V_{BAT} functionality is no more available and VBAT pin should be connected to V_{DD} .

Appendix B Application block diagrams

B.1 Sensor Hub application example

Figure 84. Sensor Hub application example

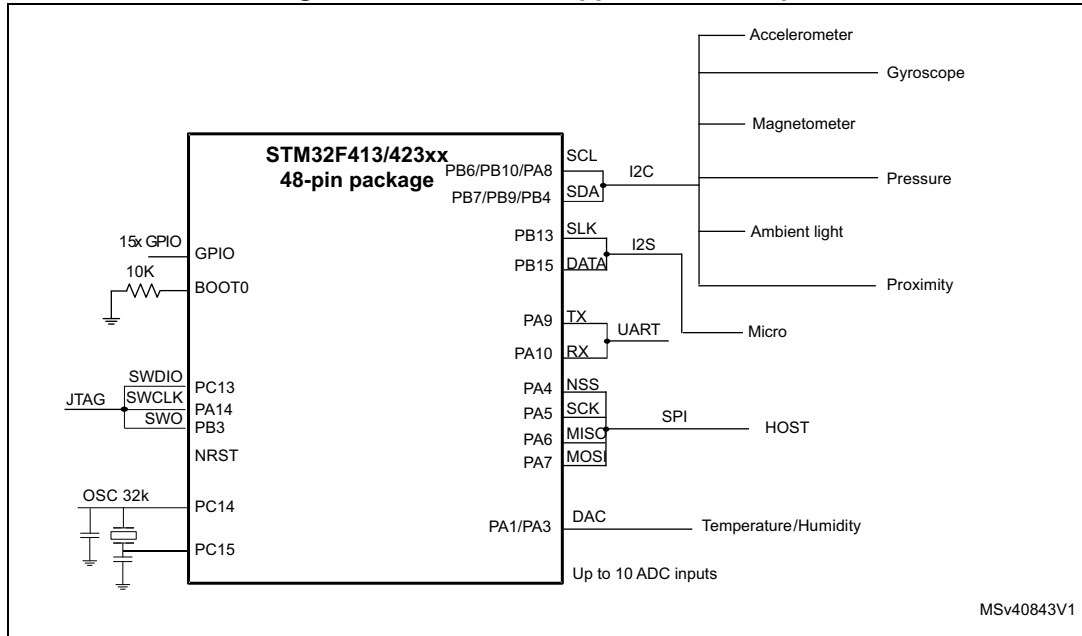

B.2 Display application example

Figure 85. Display application example

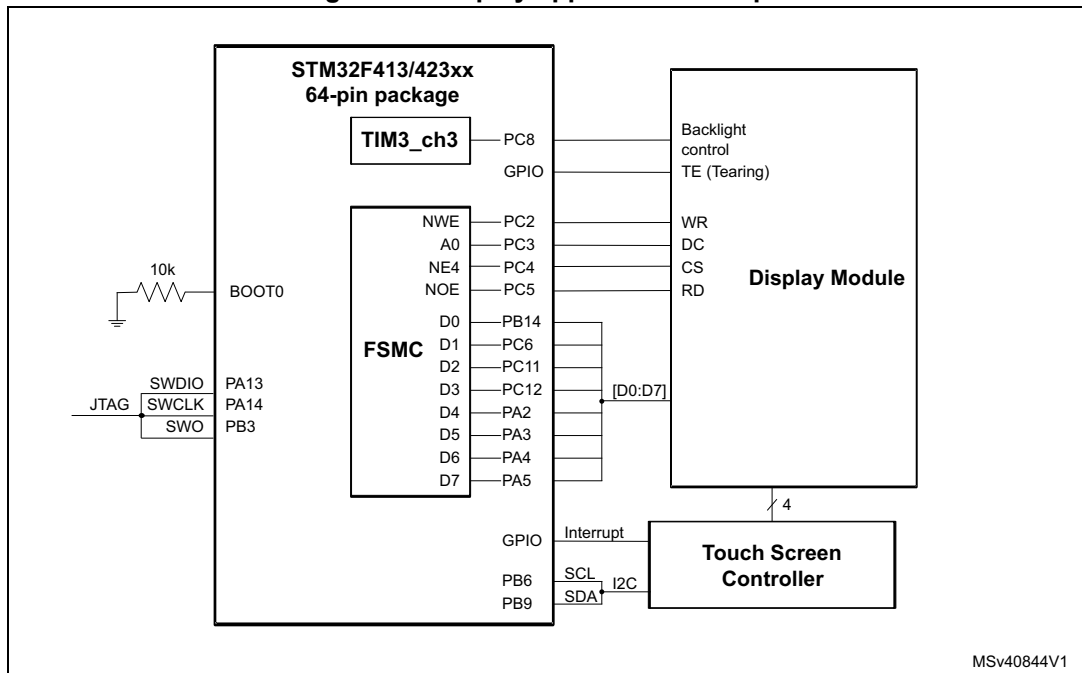

Note: 16 bit displays interfaces can be addressed with 100 and 144 pins packages.

MSv40843

B.3 USB OTG full speed (FS) interface solutions

Figure 86. USB controller configured as peripheral-only and used in Full speed mode

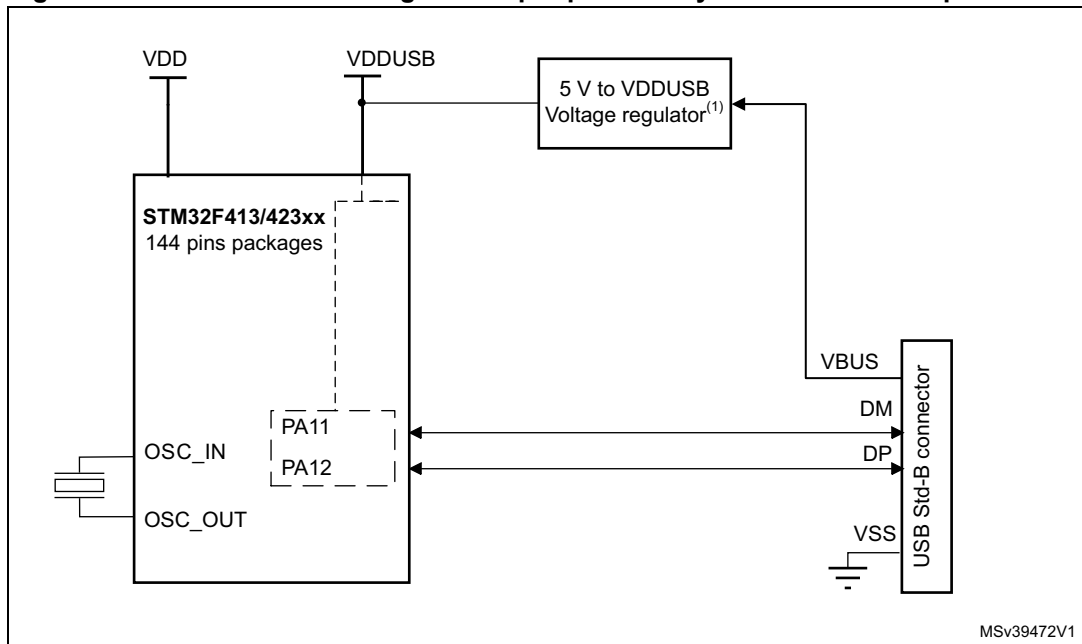

1. External voltage regulator only needed when building a V_{BUS} powered device.

Figure 87. USB peripheral-only Full speed mode with direct connection for VBUS sense

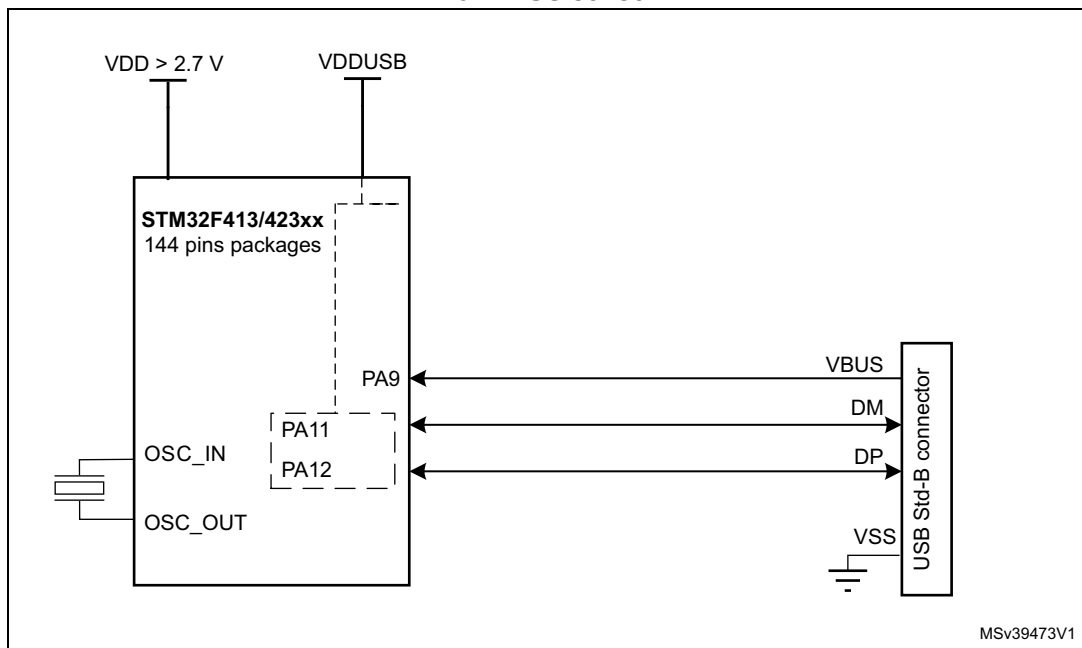

1. External voltage regulator only needed when building a V_{BUS} powered device.

Figure 88. USB peripheral-only Full speed mode, VBUS detection using GPIO

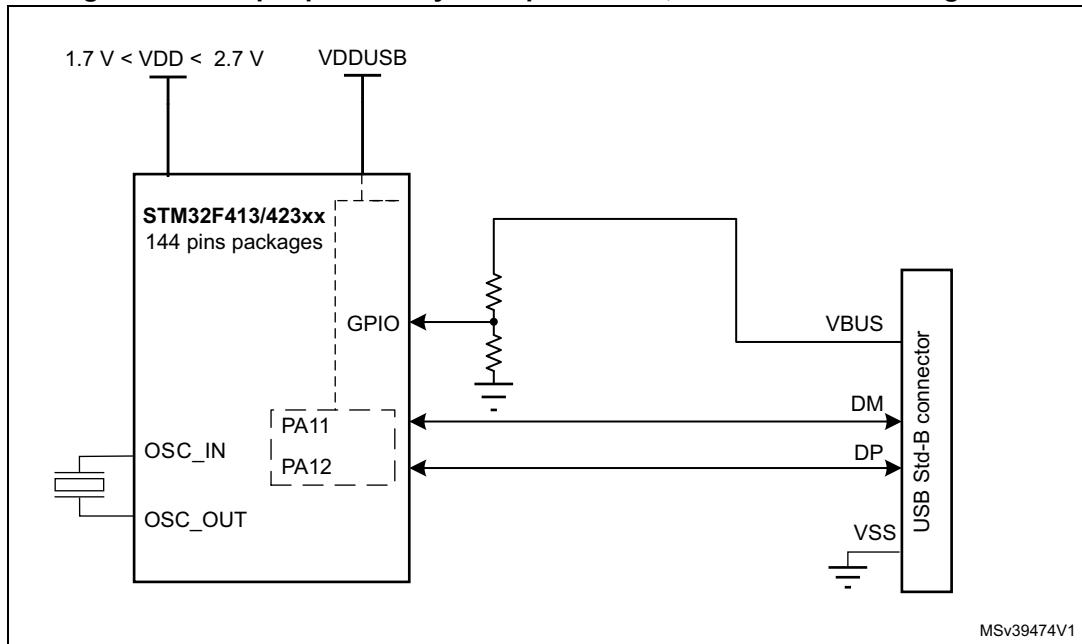

1. External voltage regulator only needed when building a V_{BUS} powered device.

Figure 89. USB controller configured as host-only and used in full speed mode

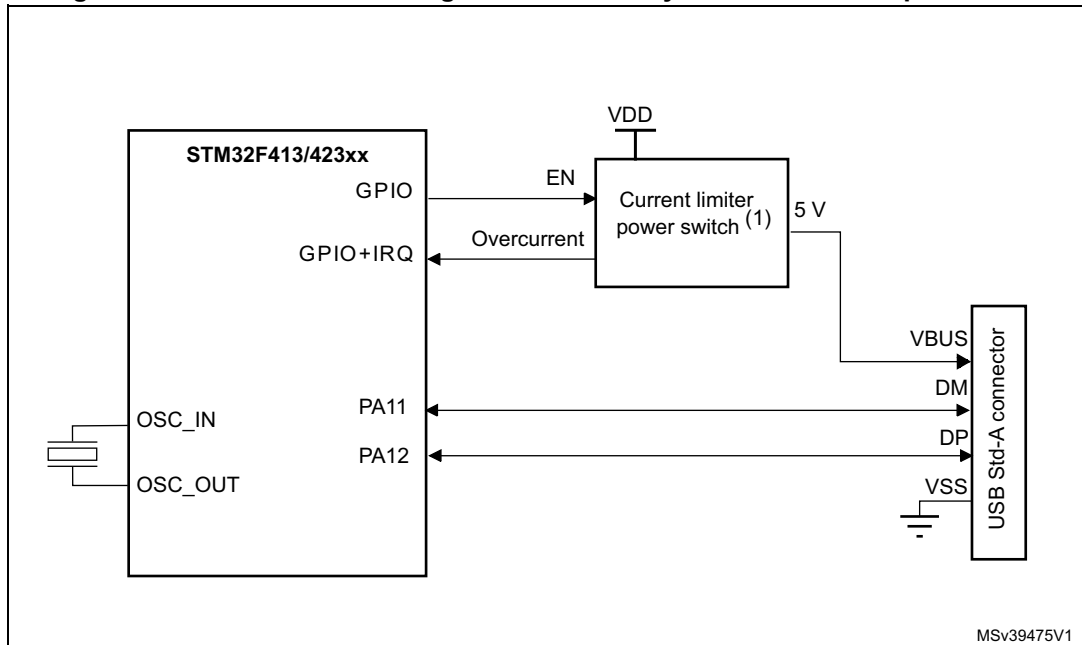

2. The current limiter is required only if the application has to support a V_{BUS} powered device. A basic power switch can be used if 5 V are available on the application board.

Revision history

Table 115. Document revision history

Date	Revision	Changes
29-Aug-2016	1	Initial release.
21-Oct-2016	2	Updated: <ul style="list-style-type: none"> – Table 10: STM32F413xG/H pin definition – Section 7: Package information – Figure 65: WLCSP81 marking example (package top view)
13-Dec-2016	3	Updated: <ul style="list-style-type: none"> – Table 39: Peripheral current consumption – Table 55: EMI characteristics for LQFP144 – Table 56: ESD absolute maximum ratings – Table 70: QSPI dynamic characteristics in SDR mode – Table 111: UFBGA144 - 144-ball, 10 x 10 mm, 0.80 mm pitch, ultra fine pitch ball grid array package mechanical data – Figure 81: UFBGA144 - 144-pin, 10 x 10 mm, 0.80 mm pitch, ultra fine pitch ball grid array package outline
09-Mar-2017	4	Updated: <ul style="list-style-type: none"> – Table 2: STM32F413xG/H features and peripheral counts – Table 12: STM32F413xG/H alternate functions Added: <ul style="list-style-type: none"> – Table 11: FSMC pin definition

Table 115. Document revision history

Date	Revision	Changes
14-Jun-2017	5	Added: – <i>Section 4.1: WLCSP81 pinout description</i> – <i>Section 4.2: UFQFPN48 pinout description</i> – <i>Section 4.3: LQFP64 pinout description</i> – <i>Section 4.4: LQFP100 pinout description</i> – <i>Section 4.5: LQFP144 pinout description</i> – <i>Section 4.6: UFBGA100 pinout description</i> – <i>Section 4.7: UFBGA144 pinout description</i> – <i>Section 4.8: Pins definition</i> – <i>Section 4.9: Alternate functions</i> Updated: – <i>Table 10: STM32F413xG/H pin definition</i> – <i>Table 11: FSMC pin definition</i> – <i>Table 38: Switching output I/O current consumption</i> – <i>Table 39: Peripheral current consumption</i>
19-Sep-2017	6	Updated: – <i>Section 3.29: Digital filter for sigma-delta modulators (DFSDM)</i> – <i>Table 53: Flash memory endurance and data retention</i> – <i>Table 59: I/O static characteristics</i> – <i>Table 75: ADC characteristics</i>

IMPORTANT NOTICE – PLEASE READ CAREFULLY

STMicroelectronics NV and its subsidiaries ("ST") reserve the right to make changes, corrections, enhancements, modifications, and improvements to ST products and/or to this document at any time without notice. Purchasers should obtain the latest relevant information on ST products before placing orders. ST products are sold pursuant to ST's terms and conditions of sale in place at the time of order acknowledgement.

Purchasers are solely responsible for the choice, selection, and use of ST products and ST assumes no liability for application assistance or the design of Purchasers' products.

No license, express or implied, to any intellectual property right is granted by ST herein.

Resale of ST products with provisions different from the information set forth herein shall void any warranty granted by ST for such product.

ST and the ST logo are trademarks of ST. All other product or service names are the property of their respective owners.

Information in this document supersedes and replaces information previously supplied in any prior versions of this document.

© 2017 STMicroelectronics – All rights reserved

Компания «Океан Электроники» предлагает заключение долгосрочных отношений при поставках импортных электронных компонентов на взаимовыгодных условиях!

Наши преимущества:

- Поставка оригинальных импортных электронных компонентов напрямую с производств Америки, Европы и Азии, а так же с крупнейших складов мира;
- Широкая линейка поставок активных и пассивных импортных электронных компонентов (более 30 млн. наименований);
- Поставка сложных, дефицитных, либо снятых с производства позиций;
- Оперативные сроки поставки под заказ (от 5 рабочих дней);
- Экспресс доставка в любую точку России;
- Помощь Конструкторского Отдела и консультации квалифицированных инженеров;
- Техническая поддержка проекта, помощь в подборе аналогов, поставка прототипов;
- Поставка электронных компонентов под контролем ВП;
- Система менеджмента качества сертифицирована по Международному стандарту ISO 9001;
- При необходимости вся продукция военного и аэрокосмического назначения проходит испытания и сертификацию в лаборатории (по согласованию с заказчиком);
- Поставка специализированных компонентов военного и аэрокосмического уровня качества (Xilinx, Altera, Analog Devices, Intersil, Interpoint, Microsemi, Actel, Aeroflex, Peregrine, VPT, Syfer, Eurofarad, Texas Instruments, MS Kennedy, Miteq, Cobham, E2V, MA-COM, Hittite, Mini-Circuits, General Dynamics и др.);

Компания «Океан Электроники» является официальным дистрибьютором и эксклюзивным представителем в России одного из крупнейших производителей разъемов военного и аэрокосмического назначения «JONHON», а так же официальным дистрибьютором и эксклюзивным представителем в России производителя высокотехнологичных и надежных решений для передачи СВЧ сигналов «FORSTAR».



JONHON

«JONHON» (основан в 1970 г.)

Разъемы специального, военного и аэрокосмического назначения:

(Применяются в военной, авиационной, аэрокосмической, морской, железнодорожной, горно- и нефтедобывающей отраслях промышленности)

«FORSTAR» (основан в 1998 г.)

ВЧ соединители, коаксиальные кабели, кабельные сборки и микроволновые компоненты:

(Применяются в телекоммуникациях гражданского и специального назначения, в средствах связи, РЛС, а так же военной, авиационной и аэрокосмической отраслях промышленности).



Телефон: 8 (812) 309-75-97 (многоканальный)

Факс: 8 (812) 320-03-32

Электронная почта: ocean@oceanchips.ru

Web: <http://oceanchips.ru/>

Адрес: 198099, г. Санкт-Петербург, ул. Калинина, д. 2, корп. 4, лит. А