



Is Now Part of



ON Semiconductor®

To learn more about ON Semiconductor, please visit our website at
www.onsemi.com

Please note: As part of the Fairchild Semiconductor integration, some of the Fairchild orderable part numbers will need to change in order to meet ON Semiconductor's system requirements. Since the ON Semiconductor product management systems do not have the ability to manage part nomenclature that utilizes an underscore (_), the underscore (_) in the Fairchild part numbers will be changed to a dash (-). This document may contain device numbers with an underscore (_). Please check the ON Semiconductor website to verify the updated device numbers. The most current and up-to-date ordering information can be found at www.onsemi.com. Please email any questions regarding the system integration to Fairchild_questions@onsemi.com.

ON Semiconductor and the ON Semiconductor logo are trademarks of Semiconductor Components Industries, LLC dba ON Semiconductor or its subsidiaries in the United States and/or other countries. ON Semiconductor owns the rights to a number of patents, trademarks, copyrights, trade secrets, and other intellectual property. A listing of ON Semiconductor's product/patent coverage may be accessed at www.onsemi.com/site/pdf/Patent-Marking.pdf. ON Semiconductor reserves the right to make changes without further notice to any products herein. ON Semiconductor makes no warranty, representation or guarantee regarding the suitability of its products for any particular purpose, nor does ON Semiconductor assume any liability arising out of the application or use of any product or circuit, and specifically disclaims any and all liability, including without limitation special, consequential or incidental damages. Buyer is responsible for its products and applications using ON Semiconductor products, including compliance with all laws, regulations and safety requirements or standards, regardless of any support or applications information provided by ON Semiconductor. "Typical" parameters which may be provided in ON Semiconductor data sheets and/or specifications can and do vary in different applications and actual performance may vary over time. All operating parameters, including "Typicals" must be validated for each customer application by customer's technical experts. ON Semiconductor does not convey any license under its patent rights nor the rights of others. ON Semiconductor products are not designed, intended, or authorized for use as a critical component in life support systems or any FDA Class 3 medical devices or medical devices with a same or similar classification in a foreign jurisdiction or any devices intended for implantation in the human body. Should Buyer purchase or use ON Semiconductor products for any such unintended or unauthorized application, Buyer shall indemnify and hold ON Semiconductor and its officers, employees, subsidiaries, affiliates, and distributors harmless against all claims, costs, damages, and expenses, and reasonable attorney fees arising out of, directly or indirectly, any claim of personal injury or death associated with such unintended or unauthorized use, even if such claim alleges that ON Semiconductor was negligent regarding the design or manufacture of the part. ON Semiconductor is an Equal Opportunity/Affirmative Action Employer. This literature is subject to all applicable copyright laws and is not for resale in any manner.



FSUSB22 — Low-Power, 2-Port, High-Speed USB 2.0 (480Mbps) Switch

Features

- -40dB Off Isolation at 250MHz
- -40dB Non-adjacent Channel Crosstalk at 250MHz
- On Resistance: 4.5Ω Typical (R_{ON})
- -3dB Bandwidth: 750MHz
- Low-Power Consumption: 1μA Maximum
- Control Input: TTL Compatible
- Bi-directional Operation
- USB High-Speed and Full-Speed Signaling Capability

Description

FSUSB22 is a low-power, high-bandwidth switch specially designed for applications switching high-speed USB 2.0 signals in handset and consumer applications; such as cell phone, digital camera, and notebook with hubs or controllers of limited USB I/O. The wide bandwidth (750MHz) allows signals to pass with minimum edge and phase distortion. Superior channel-to-channel crosstalk results in minimal interference. It is compatible with the USB2.0 Hi-Speed standard.

Applications

- Cell Phones, PDAs, Digital Cameras, Notebook Computers

Ordering Information

Part Number	Operating Temperature Range	Package	Packing Method
FSUSB22BQX	-40 to +85°C	16-Terminal Depopulated Quad Very-Thin Flat Pack No Leads (DQFN), JEDEC MO-241, 2.5 x 3.5mm	Tape and Reel
FSUSB22QSC	-40 to +85°C	16-Lead Quarter Size Outline Package (QSOP), JEDEC MO-137, 0.150-inch Wide	Tube
FSUSB22QSCX	-40 to +85°C	16-Lead Quarter Size Outline Package (QSOP), JEDEC MO-137, 0.150-inch Wide	Tape and Reel
FSUSB22MTC	-40 to +85°C	16-Lead Thin Shrink Small Outline Package (TSSOP), JEDEC MO-153, 4.4mm Wide	Tube
FSUSB22MTCX	-40 to +85°C	16-Lead Thin Shrink Small Outline Package (TSSOP), JEDEC MO-153, 4.4mm Wide	Tape and Reel

 All packages are lead free per JEDEC: J-STD-020B standard.

Logic Diagram

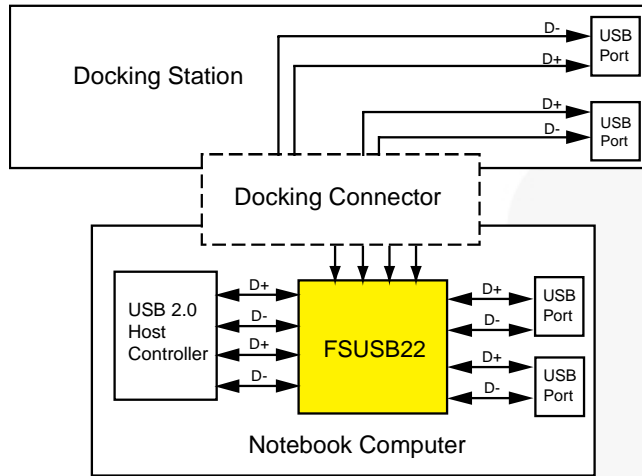

Figure 1. Logic Diagram

Analog Symbol

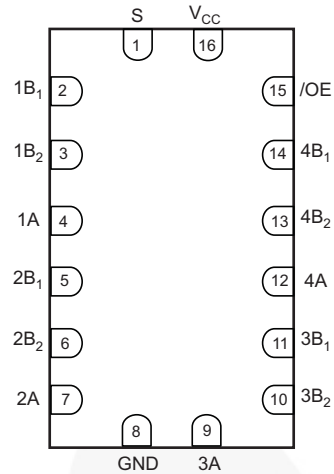

Figure 2. Analog Symbol

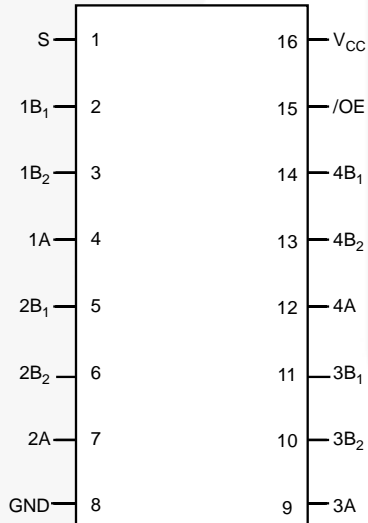

Figure 3. QSOPT and TSSOP Pin Configuration

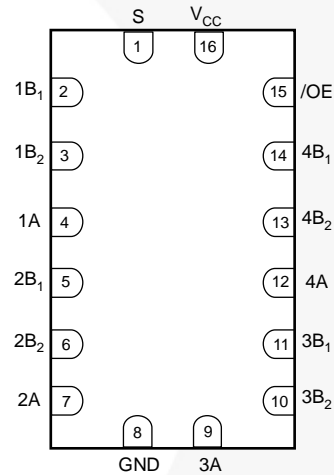

Figure 4. Pad Assignment for DQFN

Pin Descriptions

Pin #	Pin Names	Description
1	S	Select Input
2,3,5,6,10,11,13,14	1B ₁ ,1B ₂ , 2B ₁ ,2B ₂ ,3B ₁ ,3B ₂ ,4B ₁ ,4B ₂	Bus B
8	GND	Ground
4,7,9,12	1A,2A,3A,4A	Bus A
15	/OE	Bus Switch Enable
16	V _{cc}	Supply Voltage

Truth Table

S	OE	Function
Don't Care	HIGH	Disconnect
LOW	LOW	A=B ₁
HIGH	LOW	A=B ₂

Absolute Maximum Ratings

Stresses exceeding the absolute maximum ratings may damage the device. The device may not function or be operable above the recommended operating conditions and stressing the parts to these levels is not recommended. In addition, extended exposure to stresses above the recommended operating conditions may affect device reliability. The absolute maximum ratings are stress ratings only.

Symbol	Parameter	Min.	Max.	Unit
V_{CC}	Supply Voltage	-0.5	4.6	V
V_S	DC Switch Voltage	-0.5	$V_{CC} + 0.05$	V
V_{IN}	DC Input Voltage ⁽¹⁾	-0.5	4.6	V
I_{IK}	DC Input Diode Current, $V_{IN} < 0V$		-50	mA
I_{OUT}	DC Output Sink Current		128	mA
I_{CC} / I_{GND}	DC V_{CC} / GND Current		± 100	mA
T_{STG}	Storage Temperature Range	-65	+150	°C
ESD	Human Body Model, JESD22-A114		4	kV

Note:

- The input and output negative voltage ratings may be exceeded if the input and output diode current ratings are observed.

Recommended Operating Conditions

The Recommended Operating Conditions table defines the conditions for actual device operation. Recommended operating conditions are specified to ensure optimal performance to the datasheet specifications. Fairchild does not recommend exceeding them or designing to Absolute Maximum Ratings.

Symbol	Parameter	Min.	Max.	Unit	
V_{CC}	Power Supply Operating	3.0	3.6	V	
V_{IN}	Input Voltage	0	V_{CC}	V	
V_{OUT}	Output Voltage	0	V_{CC}	V	
t_r, t_f	Input Rise and Fall Time	Switch Control Input ⁽²⁾	0	5	ns/V
		Switch I/O	0	DC	
T_A	Operating Temperature, Free Air	-40	+85	°C	

Note:

- Unused control inputs must be held HIGH or LOW. They may not float.

DC Electrical Characteristics

Typical values are at $V_{CC} = 3.0V$ and $T_A = 25^\circ C$.

Symbol	Parameter	Conditions	V_{CC} (V)	$T_A = -40$ to $+85^\circ C$			Units
				Min.	Typ.	Max.	
V_{IK}	Clamp Diode Voltage	$I_{IN} = -18mA$	3.0			-1.2	V
V_{IH}	High-Level Input Voltage		3.0 to 3.6	2.0			V
V_{IL}	Low-Level Input Voltage		3.0 to 3.6			0.8	V
I_{IN}	Input Leakage Current	$0 \leq V_{IN} \leq 3.6V$	3.6			± 1.0	μA
I_{OFF}	Off-state Leakage Current	$0 \leq A, B \leq V_{CC}$	3.6			± 1.0	μA
R_{ON}	Switch On Resistance ⁽³⁾	$V_{IN} = 0.8V, I_{ON} = 8mA$	3.0		5	7	Ω
		$V_{IN} = 3.0V, I_{ON} = 8mA$	3.0		4.5	6.5	
ΔR_{ON}	Delta R_{ON}	$V_{IN} = 0.8V, V_{IN} = 0V - 1.5, I_{ON} = 8mA$	3.0		0.3		Ω
$R_{FLAT(ON)}$	On Resistance Flatness ⁽⁴⁾	$I_{OUT} = 8mA$	3.0		1		Ω
I_{CC}	Quiescent Supply Current	$V_{IN} = V_{CC}$ or GND, $I_{OUT} = 0$	3.6			1	μA

Notes:

3. Measured by the voltage drop between the A and B pins at the indicated current through the switch. On resistance is determined by the lower of the voltages on the A or B pins.
4. Flatness is defines as the difference between the maximum and the minimum value on resistance over the specified range of conditions.

AC Electrical Characteristics

Typical values are at $V_{CC} = 3.0V$ and $T_A = 25^\circ C$.

Symbol	Parameter	Conditions	$V_{CC}(V)$	Min.	Typ.	Max.	Units	Figure
t_{ON}	Turn-on Time S-to-Bus B		3.0 to 3.6		4.5	6.0	ns	Figure 9 Figure 10
t_{OFF}	Turn-off Time S-to-Bus B		3.0 to 3.6		2.5	4.0	ns	Figure 9 Figure 10
t_{PD}	Propagation Delay	$C_L = 10pF$	3.0 to 3.6		0.25		ns	Figure 14
O_{IRR}	Non-Adjacent Off Isolation	$f = 250MHz,$ $R_L = 50\Omega$	3.0 to 3.6		-30		dB	Figure 11
X_{TALK}	Non-Adjacent Channel Crosstalk	$f = 250MHz,$ $R_L = 50\Omega$	3.0 to 3.6		-38		dB	Figure 12
BW	-3dB Bandwidth	$R_L = 50\Omega$	3.0 to 3.6		750		MHz	Figure 13

USB Related AC Electrical Characteristics

Typical values are at $V_{CC} = 3.0V$ and $T_A = 25^\circ C$.

Symbol	Parameter	Conditions	$V_{CC} (V)$	Min.	Typ.	Max.	Units	Figure
$t_{SK(O)}$	Channel-to Channels Skew	$C_L = 10pF$	3.0 to 3.6		0.051		pF	Figure 14 Figure 16
$t_{SK(P)}$	Skew of Opposite Transition of the Same Output	$C_L = 10pF$	3.0 to 3.6		0.020		pF	Figure 14 Figure 16
T_J	Total Jitter	$R_L = 50\Omega,$ $C_L = 10pF$ $t_R = t_F = 750ps$ at 480MPs	3.0 to 3.6		0.210			

Capacitance

Typical values are at $V_{CC} = 3.0V$ and $T_A = 25^\circ C$.

Symbol	Parameter	Conditions	Typ.	Units
C_{IN}	Control Pin Input Capacitance	$V_{CC} = 0V$	2.5	pF
C_{ON}	A/B On Capacitance	$V_{CC} = 3.3V, /OE = 0V$	12	pF
C_{OFF}	Port B Off Capacitance	V_{CC} and $/OE = 3.3V$	4.5	pF

Performance Characteristics

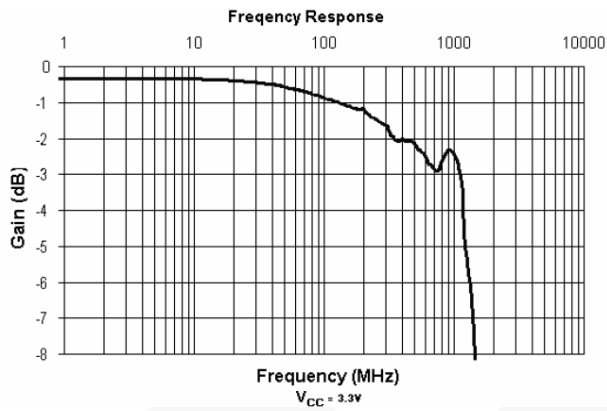

Figure 5. Gain vs. Frequency

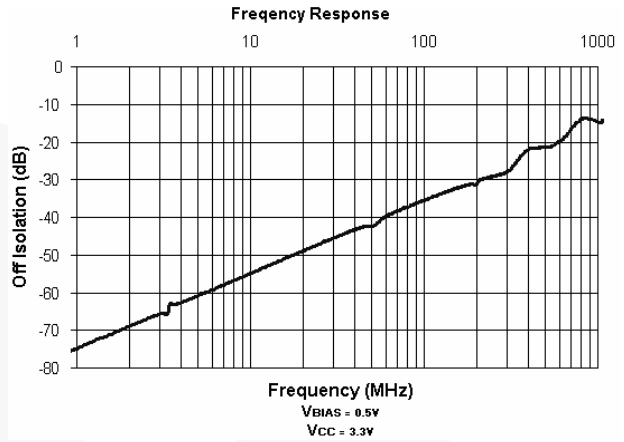

Figure 6. Off Isolation

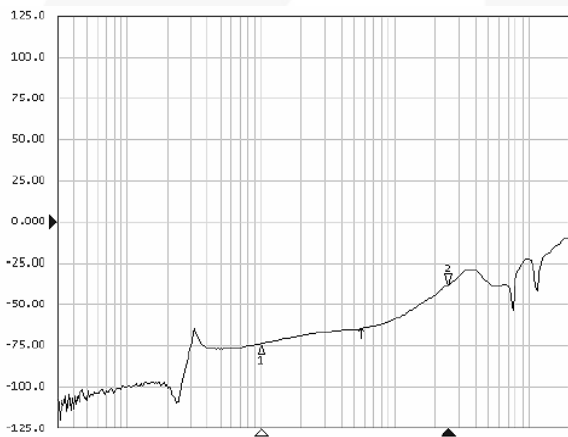

Figure 7. Crosstalk

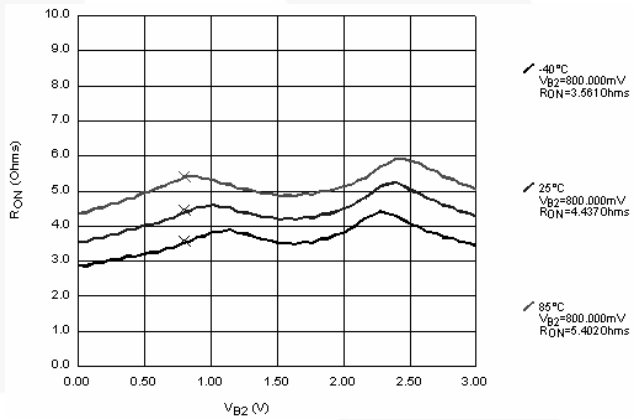
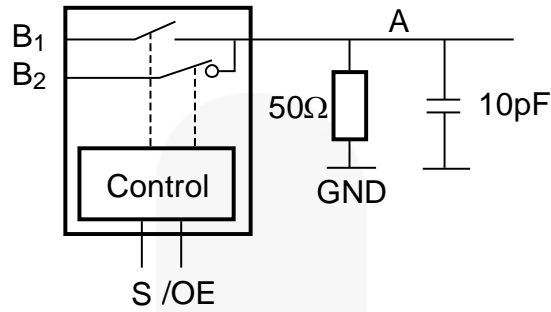

Figure 8. R_{ON}

AC Loadings and Waveforms



Notes: Input driven by 50Ω source terminated in 50Ω.
 CL includes load and stray capacitance.
 Input PRR-1.0MHz, $t_w = 500\text{ns}$.

Figure 9. AC Test Circuit

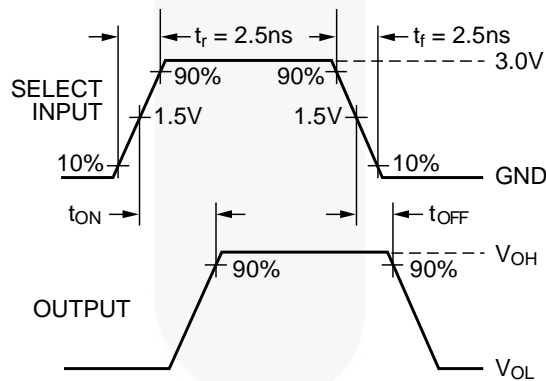

Figure 10. AC Waveforms

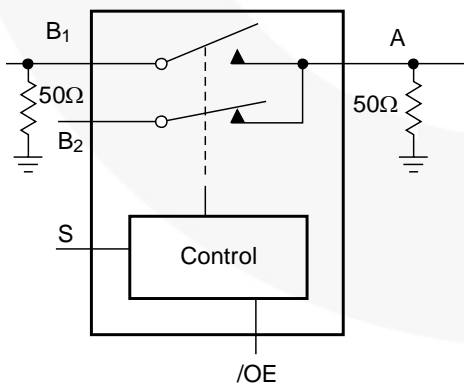

Figure 11. Off Isolation Test

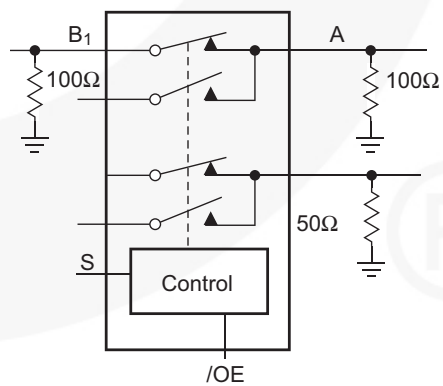

Figure 12. Crosstalk Test

AC Loadings and Waveforms

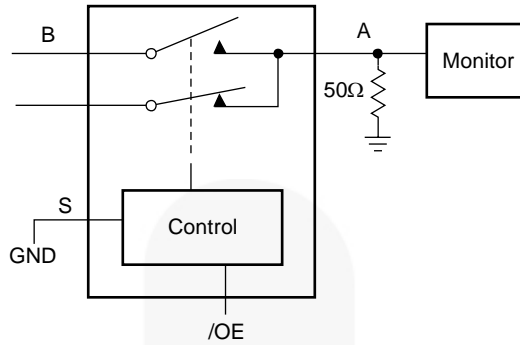

Figure 13. Bandwidth Test

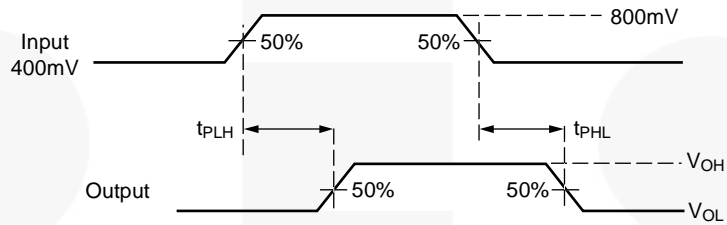

Figure 14. Propagation Delay

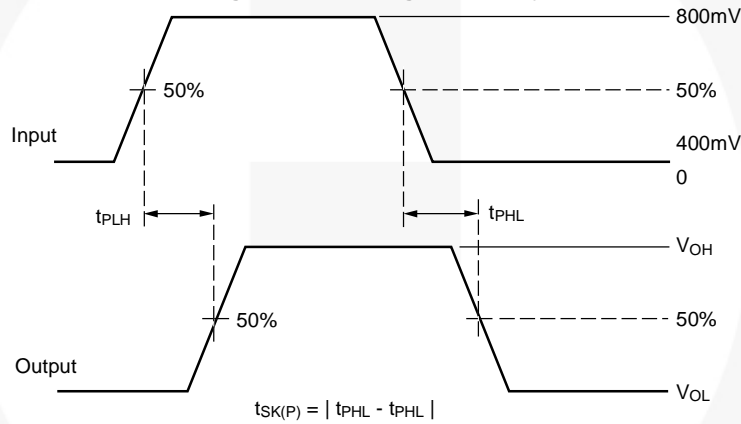

Figure 15. Pulse Skew $t_{SK(P)}$

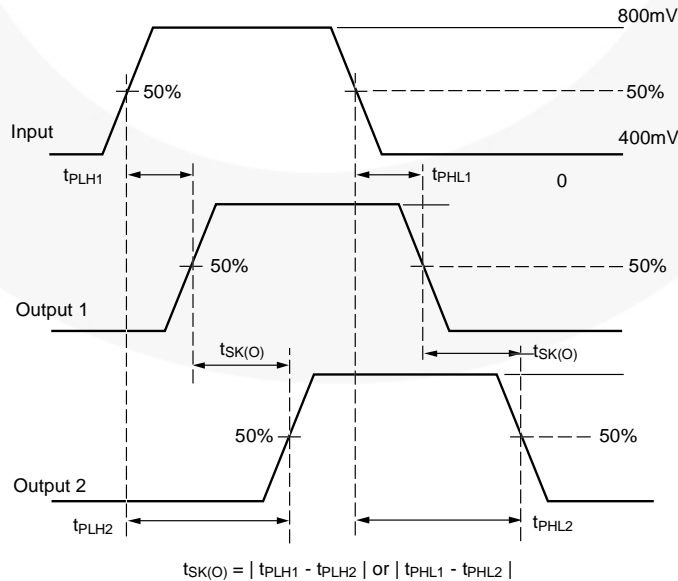
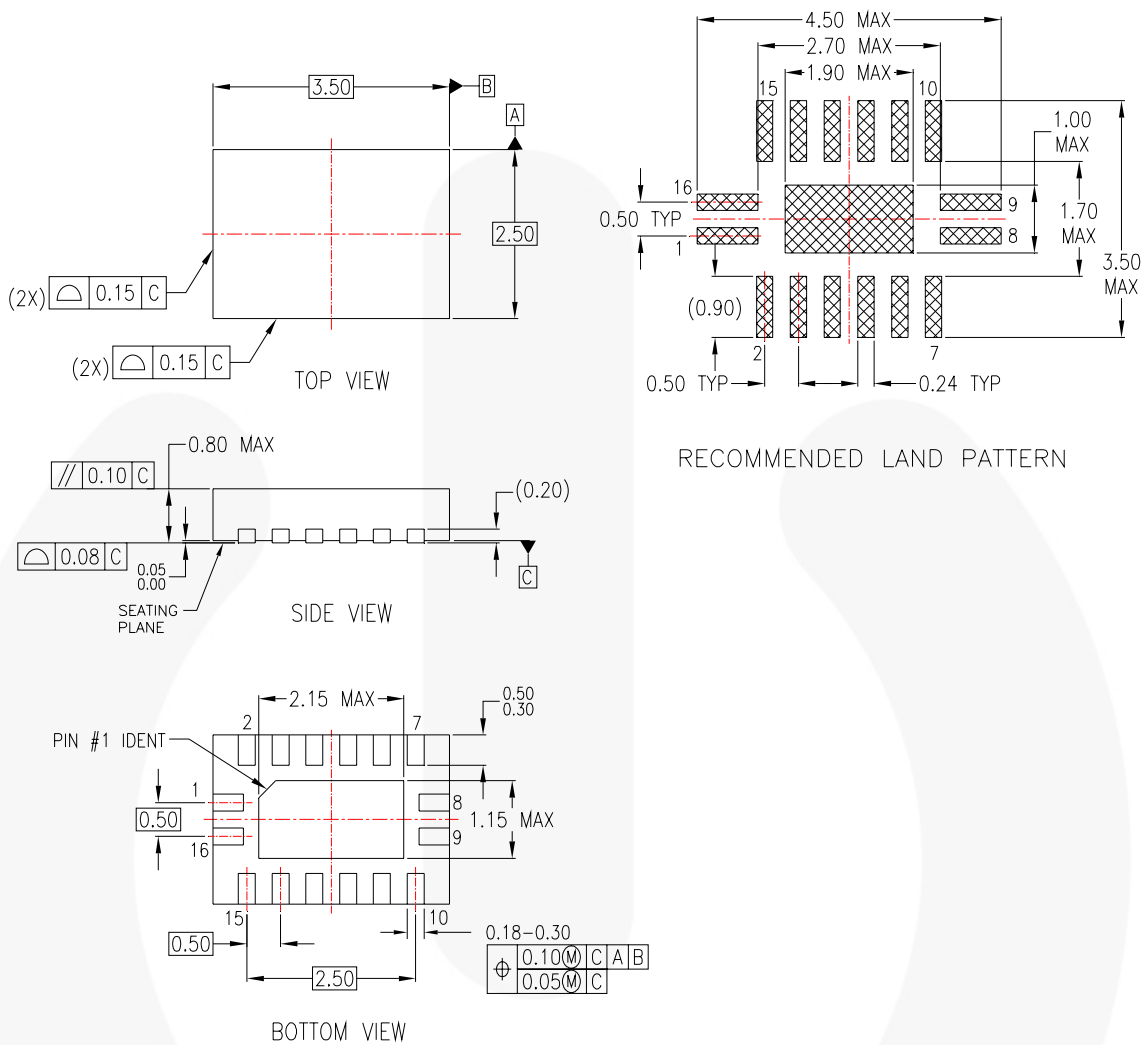

Figure 16. Output Skew $t_{SK(O)}$

Physical Dimensions



NOTES:

- A. CONFORMS TO JEDEC REGISTRATION MO-241, VARIATION AB
- B. DIMENSIONS ARE IN MILLIMETERS.
- C. DIMENSIONS AND TOLERANCES PER ASME Y14.5M, 1994

MLP16ErevA

Figure 17. 16-Terminal Depopulated Quad Very-Thin Flat Pack No Leads (DQFN), JEDEC MO-241, 2.5 x 3.5mm

Note: [click here for tape and reel specifications, available at: http://www.fairchildsemi.com/products/analog/pdf/MLP16_25x35_TNR.pdf](http://www.fairchildsemi.com/products/analog/pdf/MLP16_25x35_TNR.pdf)

Package drawings are provided as a service to customers considering Fairchild components. Drawings may change in any manner without notice. Please note the revision and/or date on the drawing and contact a Fairchild Semiconductor representative to verify or obtain the most recent revision. Package specifications do not expand the terms of Fairchild's worldwide terms and conditions, specifically the warranty therein, which covers Fairchild products.

Always visit Fairchild Semiconductor's online packaging area for the most recent package drawings:
<http://www.fairchildsemi.com/packaging/>

Physical Dimensions

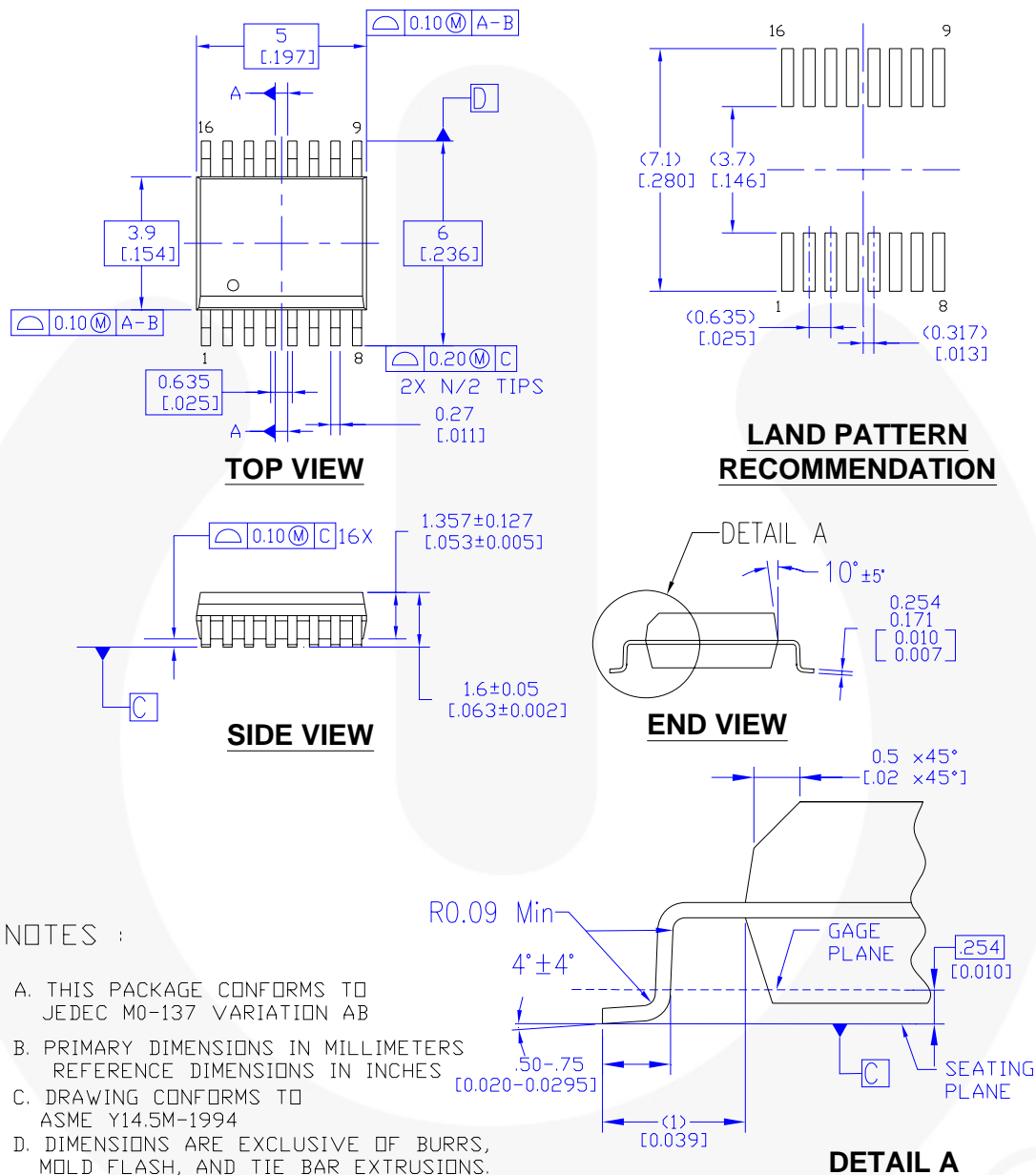

NOTES :

- A. THIS PACKAGE CONFORMS TO JEDEC MO-137 VARIATION AB
- B. PRIMARY DIMENSIONS IN MILLIMETERS
REFERENCE DIMENSIONS IN INCHES
- C. DRAWING CONFORMS TO ASME Y14.5M-1994
- D. DIMENSIONS ARE EXCLUSIVE OF BURRS, MOLD FLASH, AND TIE BAR EXTRUSIONS.

MQA16AREVB

Figure 18. 16-Lead Quarter Size Outline Package (QSOP), JEDEC MO-137, 0.150-inch Wide

Package drawings are provided as a service to customers considering Fairchild components. Drawings may change in any manner without notice. Please note the revision and/or date on the drawing and contact a Fairchild Semiconductor representative to verify or obtain the most recent revision. Package specifications do not expand the terms of Fairchild's worldwide terms and conditions, specifically the warranty therein, which covers Fairchild products.

Always visit Fairchild Semiconductor's online packaging area for the most recent package drawings:
<http://www.fairchildsemi.com/packaging/>

Physical Dimensions

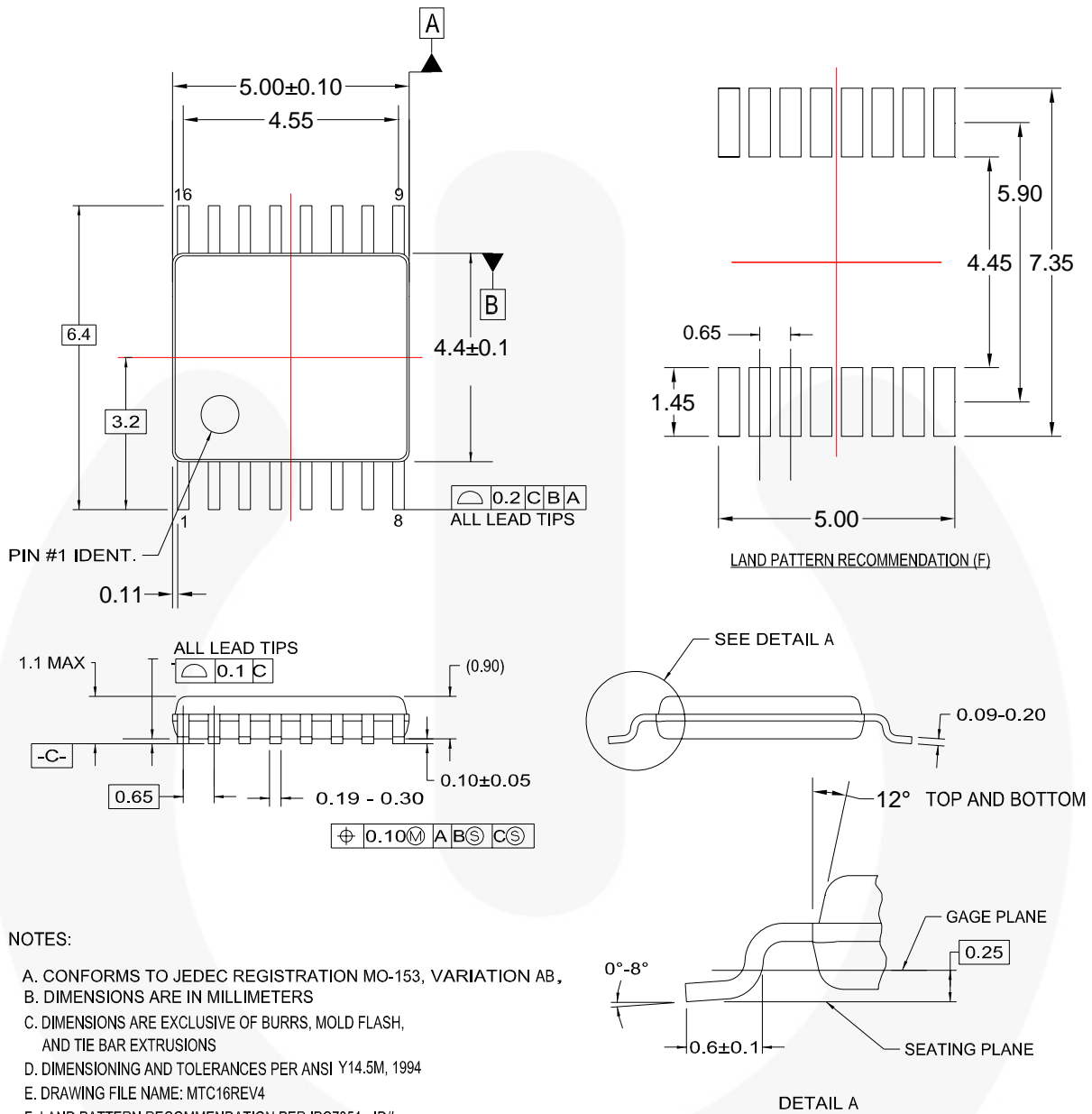

MTC16rev4

Figure 19. 16-Lead Thin Shrink Small Outline Package (TSSOP), JEDEC MO-153, 4.4mm Wide

Package drawings are provided as a service to customers considering Fairchild components. Drawings may change in any manner without notice. Please note the revision and/or date on the drawing and contact a Fairchild Semiconductor representative to verify or obtain the most recent revision. Package specifications do not expand the terms of Fairchild's worldwide terms and conditions, specifically the warranty therein, which covers Fairchild products.

Always visit Fairchild Semiconductor's online packaging area for the most recent package drawings:
<http://www.fairchildsemi.com/packaging/>



TRADEMARKS

The following includes registered and unregistered trademarks and service marks, owned by Fairchild Semiconductor and/or its global subsidiaries, and is not intended to be an exhaustive list of all such trademarks.

- | | | | |
|---|---|---|---|
| ACEx [®] | FPST [™] | PDP SPM [™] | The Power Franchise [®] |
| Build it Now [™] | F-PFS [™] | Power-SPM [™] |  |
| CorePLUS [™] | FRFET [®] | PowerTrench [®] | TinyBoost [™] |
| CorePOWER [™] | Global Power Resource SM | Programmable Active Droop [™] | TinyBuck [™] |
| CROSSVOLT [™] | Green FPST [™] | QFET [®] | TinyLogic [®] |
| CTL [™] | Green FPST [™] e-Series [™] | QST [™] | TINYOPTO [™] |
| Current Transfer Logic [™] | GTO [™] | Quiet Series [™] | TinyPower [™] |
| EcoSPARK [®] | IntelliMAX [™] | RapidConfigure [™] | TinyPWM [™] |
| EfficientMax [™] | ISOPLANAR [™] | Saving our world, 1mW at a time [™] | TinyWire [™] |
| EZSWITCH [™] * | MegaBuck [™] | SmartMax [™] | μSerDes [™] |
|  | MICROCOUPLER [™] | SMART START [™] |  |
|  | MicroFET [™] | SPM [®] | UHC [®] |
| Fairchild [®] | MicroPak [™] | STEALTH [™] | Ultra FRFET [™] |
| Fairchild Semiconductor [®] | MillerDrive [™] | SuperFET [™] | UniFET [™] |
| FACT Quiet Series [™] | MotionMax [™] | SuperSOT [™] -3 | VCX [™] |
| FACT [®] | Motion-SPM [™] | SuperSOT [™] -6 | VisualMax [™] |
| FAST [®] | OPTOLOGIC [®] | SuperSOT [™] -8 | |
| FastvCore [™] | OPTOPLANAR [®] | SupreMOS [™] | |
| FlashWriter [®] * | | SyncFET [™] | |
| | |  | |

* EZSWITCH[™] and FlashWriter[®] are trademarks of System General Corporation, used under license by Fairchild Semiconductor.

DISCLAIMER

FAIRCHILD SEMICONDUCTOR RESERVES THE RIGHT TO MAKE CHANGES WITHOUT FURTHER NOTICE TO ANY PRODUCTS HEREIN TO IMPROVE RELIABILITY, FUNCTION, OR DESIGN. FAIRCHILD DOES NOT ASSUME ANY LIABILITY ARISING OUT OF THE APPLICATION OR USE OF ANY PRODUCT OR CIRCUIT DESCRIBED HEREIN; NEITHER DOES IT CONVEY ANY LICENSE UNDER ITS PATENT RIGHTS, NOR THE RIGHTS OF OTHERS. THESE SPECIFICATIONS DO NOT EXPAND THE TERMS OF FAIRCHILD'S WORLDWIDE TERMS AND CONDITIONS, SPECIFICALLY THE WARRANTY THEREIN, WHICH COVERS THESE PRODUCTS.

LIFE SUPPORT POLICY

FAIRCHILD'S PRODUCTS ARE NOT AUTHORIZED FOR USE AS CRITICAL COMPONENTS IN LIFE SUPPORT DEVICES OR SYSTEMS WITHOUT THE EXPRESS WRITTEN APPROVAL OF FAIRCHILD SEMICONDUCTOR CORPORATION.

As used herein:

1. Life support devices or systems are devices or systems which, (a) are intended for surgical implant into the body or (b) support or sustain life, and (c) whose failure to perform when properly used in accordance with instructions for use provided in the labeling, can be reasonably expected to result in a significant injury of the user.
2. A critical component in any component of a life support, device, or system whose failure to perform can be reasonably expected to cause the failure of the life support device or system, or to affect its safety or effectiveness.

PRODUCT STATUS DEFINITIONS

Definition of Terms

Datasheet Identification	Product Status	Definition
Advance Information	Formative / In Design	This datasheet contains the design specifications for product development. Specifications may change in any manner without notice.
Preliminary	First Production	This datasheet contains preliminary data; supplementary data will be published at a later date. Fairchild Semiconductor reserves the right to make changes at any time without notice to improve design.
No Identification Needed	Full Production	This datasheet contains final specifications. Fairchild Semiconductor reserves the right to make changes at any time without notice to improve the design.
Obsolete	Not In Production	This datasheet contains specifications on a product that is discontinued by Fairchild Semiconductor. The datasheet is for reference information only.

Rev. I34

ON Semiconductor and  are trademarks of Semiconductor Components Industries, LLC dba ON Semiconductor or its subsidiaries in the United States and/or other countries. ON Semiconductor owns the rights to a number of patents, trademarks, copyrights, trade secrets, and other intellectual property. A listing of ON Semiconductor's product/patent coverage may be accessed at www.onsemi.com/site/pdf/Patent-Marking.pdf. ON Semiconductor reserves the right to make changes without further notice to any products herein. ON Semiconductor makes no warranty, representation or guarantee regarding the suitability of its products for any particular purpose, nor does ON Semiconductor assume any liability arising out of the application or use of any product or circuit, and specifically disclaims any and all liability, including without limitation special, consequential or incidental damages. Buyer is responsible for its products and applications using ON Semiconductor products, including compliance with all laws, regulations and safety requirements or standards, regardless of any support or applications information provided by ON Semiconductor. "Typical" parameters which may be provided in ON Semiconductor data sheets and/or specifications can and do vary in different applications and actual performance may vary over time. All operating parameters, including "Typicals" must be validated for each customer application by customer's technical experts. ON Semiconductor does not convey any license under its patent rights nor the rights of others. ON Semiconductor products are not designed, intended, or authorized for use as a critical component in life support systems or any FDA Class 3 medical devices or medical devices with a same or similar classification in a foreign jurisdiction or any devices intended for implantation in the human body. Should Buyer purchase or use ON Semiconductor products for any such unintended or unauthorized application, Buyer shall indemnify and hold ON Semiconductor and its officers, employees, subsidiaries, affiliates, and distributors harmless against all claims, costs, damages, and expenses, and reasonable attorney fees arising out of, directly or indirectly, any claim of personal injury or death associated with such unintended or unauthorized use, even if such claim alleges that ON Semiconductor was negligent regarding the design or manufacture of the part. ON Semiconductor is an Equal Opportunity/Affirmative Action Employer. This literature is subject to all applicable copyright laws and is not for resale in any manner.

PUBLICATION ORDERING INFORMATION

LITERATURE FULFILLMENT:

Literature Distribution Center for ON Semiconductor
19521 E. 32nd Pkwy, Aurora, Colorado 80011 USA
Phone: 303-675-2175 or 800-344-3860 Toll Free USA/Canada
Fax: 303-675-2176 or 800-344-3867 Toll Free USA/Canada
Email: orderlit@onsemi.com

N. American Technical Support: 800-282-9855 Toll Free
USA/Canada
Europe, Middle East and Africa Technical Support:
Phone: 421 33 790 2910
Japan Customer Focus Center
Phone: 81-3-5817-1050

ON Semiconductor Website: www.onsemi.com
Order Literature: <http://www.onsemi.com/orderlit>
For additional information, please contact your local
Sales Representative

Mouser Electronics

Authorized Distributor

Click to View Pricing, Inventory, Delivery & Lifecycle Information:

[ON Semiconductor:](#)

[FSUSB22MTCX](#) [FSUSB22BQX](#) [FSUSB22QSCX](#)

Компания «Океан Электроники» предлагает заключение долгосрочных отношений при поставках импортных электронных компонентов на взаимовыгодных условиях!

Наши преимущества:

- Поставка оригинальных импортных электронных компонентов напрямую с производств Америки, Европы и Азии, а так же с крупнейших складов мира;
- Широкая линейка поставок активных и пассивных импортных электронных компонентов (более 30 млн. наименований);
- Поставка сложных, дефицитных, либо снятых с производства позиций;
- Оперативные сроки поставки под заказ (от 5 рабочих дней);
- Экспресс доставка в любую точку России;
- Помощь Конструкторского Отдела и консультации квалифицированных инженеров;
- Техническая поддержка проекта, помощь в подборе аналогов, поставка прототипов;
- Поставка электронных компонентов под контролем ВП;
- Система менеджмента качества сертифицирована по Международному стандарту ISO 9001;
- При необходимости вся продукция военного и аэрокосмического назначения проходит испытания и сертификацию в лаборатории (по согласованию с заказчиком);
- Поставка специализированных компонентов военного и аэрокосмического уровня качества (Xilinx, Altera, Analog Devices, Intersil, Interpoint, Microsemi, Actel, Aeroflex, Peregrine, VPT, Syfer, Eurofarad, Texas Instruments, MS Kennedy, Miteq, Cobham, E2V, MA-COM, Hittite, Mini-Circuits, General Dynamics и др.);

Компания «Океан Электроники» является официальным дистрибьютором и эксклюзивным представителем в России одного из крупнейших производителей разъемов военного и аэрокосмического назначения «JONHON», а так же официальным дистрибьютором и эксклюзивным представителем в России производителя высокотехнологичных и надежных решений для передачи СВЧ сигналов «FORSTAR».



JONHON

«JONHON» (основан в 1970 г.)

Разъемы специального, военного и аэрокосмического назначения:

(Применяются в военной, авиационной, аэрокосмической, морской, железнодорожной, горно- и нефтедобывающей отраслях промышленности)

«FORSTAR» (основан в 1998 г.)

ВЧ соединители, коаксиальные кабели,
кабельные сборки и микроволновые компоненты:

(Применяются в телекоммуникациях гражданского и специального назначения, в средствах связи, РЛС, а так же военной, авиационной и аэрокосмической отраслях промышленности).



Телефон: 8 (812) 309-75-97 (многоканальный)

Факс: 8 (812) 320-03-32

Электронная почта: ocean@oceanchips.ru

Web: <http://oceanchips.ru/>

Адрес: 198099, г. Санкт-Петербург, ул. Калинина, д. 2, корп. 4, лит. А