



ON Semiconductor

## Utilizing GaN HEMTs in an All-in-One Workstation Power Supply

### Introduction

The all-in-one workstation is getting sleeker and lighter with every new model. One of the key enablers to this trend is lighter and small form-factor power converter which is typically achieved by switching the power converter at a high frequency. High frequency switching leads to smaller and lighter passive components such as transformers, inductors and capacitors. A key impediment for high switching frequency operation is the switching & driving losses of the traditional silicon MOSFETs. **GaN HEMTs** (Gallium Nitride –High Electron Mobility Transistor) offer low gate charge and on-resistance compared to the traditional MOSFETs enabling high frequency power conversion. *GaN HEMTs switch very fast and the resulting dv/dt is high. Therefore, it requires special probing techniques that are highlighted towards the end of this application note.*

This application note describes the performance of a 12 V/20 A all-in-one computer power supply using GaN HEMTs as the switching devices. The front-end of the power converter converts a universal AC line to a 385 DC bus while achieving near unity power factor. The second stage is a DC-DC stage that converts the 385 V DC bus to a 12 V output with a max rated load current of 20 A.

### Power Converter Specifications

The demo board has been designed as a universal input 240 watt board. It produces a 12 volt dc output voltage, at up to 20 A load current. The power factor is greater than 98% at low line and the T.H.D is less than 17% at full load. Table 1 list out all the specifications.

Requirement	Min.	Max.	Unit
Input Voltage (ac)	90	265	V
Output Voltage (dc)	-	12	V
Output Current(dc)	0	20	A
Output Power	0	240	W
Power Factor	-	>98	%

Table 1 Demo Board Specifications

### Overview of the Architecture

An overview of the architecture is shown in the Figure 1 below. The front- end converts the AC into a regulated 385 V DC bus. This is achieved using a power factor correction (PFC) IC employing a topology. The inductor current in the boost converter works in CCM (Continuous. Conduction Mode). The Boost PFC stage employs ON Semiconductor’s NCP1654 controller. The second stage is an isolated DC-DC converter that converts the 385 V DC bus to a 12 V dc voltage output. The isolated DC-DC conversion is achieved using a resonant topology popularly known as LLC topology. Synchronous rectifiers are used on the secondary for higher efficiency. The LLC power converter employs ON’s NCP1397 while the synchronous rectifier driver is NCP4304. The NCP432 is utilized in the feedback path to regulate the output voltage. The board utilizes GaN HEMTs from Transphorm Inc. as the switching devices in both the PFC stage and in the primary side of the LLC stage.

## DN05067/D

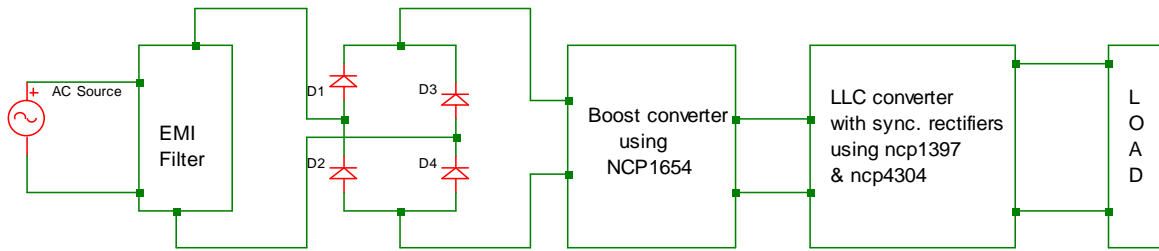

Figure1 Block Diagram of the demo board

## GaN HEMTs

The demonstration board uses TPH3002PS GaN based switches from Transphorm Inc. The TPH3002PS includes a GaN HEMT and a low-voltage, low Rds(on) silicon FET in a cascode structure as shown in the figure. Therefore, the control terminal aka gate is that of a standard silicon FET. These devices have a low Rds(on), and high dv/dt. Traditional silicon has a dv/dt of less than 50V/ns while TPH3002PS has a dv/dt of >100V/ns. These factors result in low switching and conduction losses. TPH3002PS has low Qrr which result in minimal reverse recovery losses. Some of the parameters of TPH3002PS are given in the table below

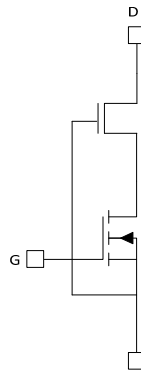

Figure 2. Cascoded GaN HEMT and Low Voltage Silicon FET

S.No	Parameter	Value	Unit	Conditions
1	Rds(on)	0.29	mOhm	Id = 9 A continuous current
2	Qg	6.2	nC	
3	Qrr	29	nC	
4	Eoss	3.1	uJ	

Table 2 TPH3002PS parameters[6]

## PFC Circuit Description

As explained earlier, the inductor current in the boost PFC is in CCM. The CCM operation results in lower peak and RMS currents compared to Critical Conduction Mode (CrM). The CrM operation brings in a number of other benefits but is typically employed at lower power levels. The CCM operation greatly simplifies the design of the boost inductor and reduces the stress on the boost FET and boost diode. Also, the CCM boost works in fixed frequency simplifying the EMI filter design. NCP1654 is a simplified CCM boost PFC converter in an 8-pin package that minimizes the number of external components. Figure 3 below show a typical application circuit of the NCP1654 based PFC [1]. Salient features NCP1654 provides are mentioned below:

1. Programmable Overcurrent Protection
2. Brownout Detection
3. Overvoltage Protection
4. Soft Start
5. Continuous Conduction Mode
6. Average Current-Mode or Peak Current-Mode Operation
7. Programmable Overpower Limitation
8. Under voltage Detection for Open Loop Detection (shutdown)
9. Inrush Currents Detection

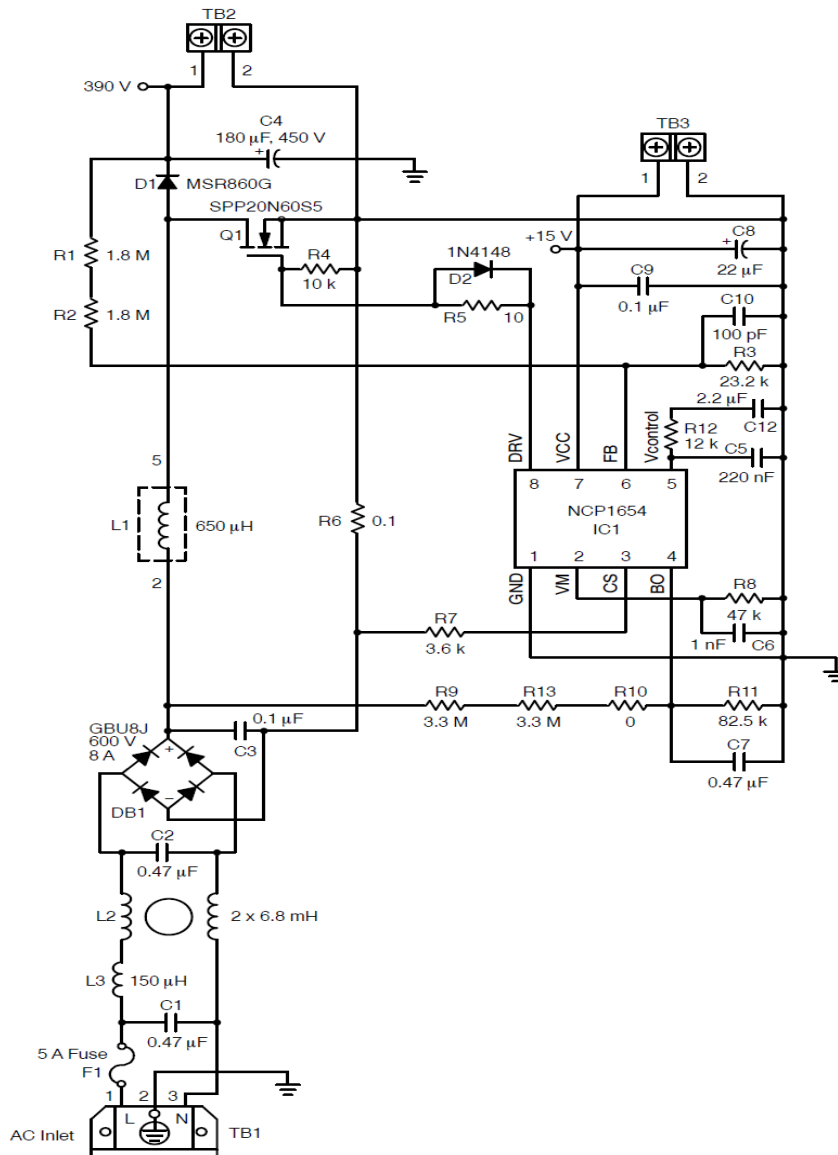

Figure 3 Typical application circuit of NCP1654 based PFC Circuit

The design table of PFC circuit is given in [6].

## LLC Circuit Description

The LLC power converter is a variant of a series resonant converter. The abbreviation LLC comes from the fact that this converter utilizes two inductors ( $L_{\text{Magnetizing}}$  and  $L_{\text{Resonant}}$ ) and a capacitor ( $C$ ) to form a resonant circuit. Typically, the leakage of the transformer acts as extra the resonant inductance in lieu of an extra discrete inductor. The LLC stage design is based on NCP1397 and NCP4304B and is explained in AND8460-D [4].

A typical application circuit of NCP1397 is shown in Figure 4[2]

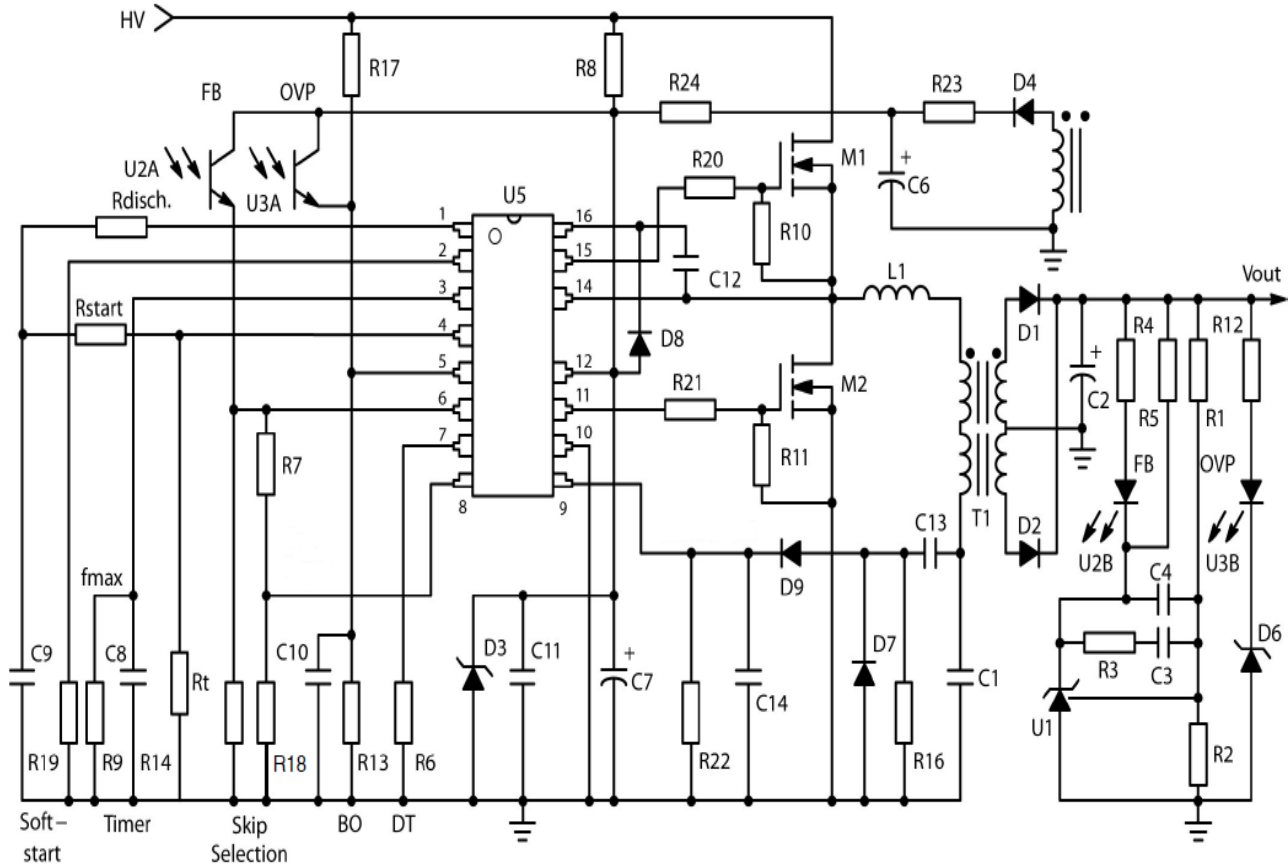

Figure 4 Typical application circuit of NCP1397

Following are the salient features of the NCP1397:

1. Adjustable minimum switching frequency with 3% accuracy
2. Brown-out input
3. 1 A / 0.5 A Peak Current Sink / Source Drive
4. Timer-based OCP input with auto-recovery
5. Second latched OCP level
6. Adjustable dead time from 100 ns to 2 us
7. Adjustable soft-start

To achieve better efficiency, synchronous rectifiers are used on the secondary of the LLC converter. The NCP4304 SR [3] controller is utilized for the control of secondary side FETs. NCP4304 is a proprietary SR controller from ON Semiconductor which provides true secondary zero current detection and automatic parasitic inductance compensation. Typical application circuit of the NCP4304 is given in Figure 5[3]. Some of its salient features are:

## DN05067/D

1. Precise True Secondary Zero Current Detection with Adjustable Threshold
2. Automatic Parasitic Inductance Compensation
3. Typically 40 ns Turn off Delay from Current Sense Input to Driver
4. Zero Current Detection Pin Capability up to 200 V
5. Optional Ultrafast Trigger Input
6. Disable Input
7. Adjustable Minimum ON Time and Minimum OFF Time
8. 5 A/2.5 A Peak Current Sink/Source Drive Capability
9. Operating Voltage Range up to 30V.

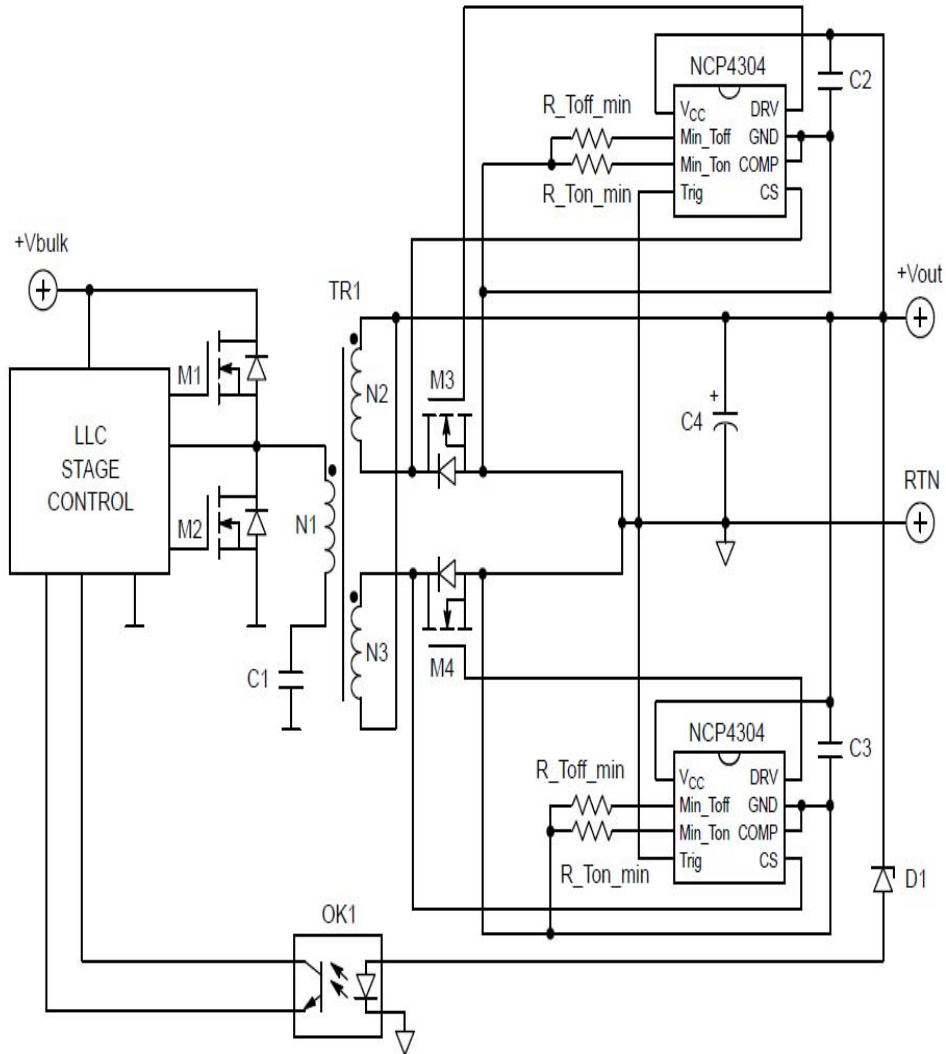

Figure 5 Typical application circuit of NCP4304B

## Performance

Efficiency, Power factor and THD were measured at low line and high line input voltages. Chroma programmable AC source 61604, Chroma power meter 66202 and Chroma electronic load 63107 were used for the measurement purpose. Table 3 and 4 show the T.H.D and Power Factor data at low and high line respectively. The graphs below show the efficiency of the boost converter, LLC converter and the complete board.

## P.F.C

### 115 Volts AC Input

S.No	Output Voltage	Output Current	T.H.D	Power Factor
1	12.062	4.997	18.537	0.9705
2	12.053	9.9663	11.62	0.9837
3	12.06	14.95	8.8442	0.9877
4	12.04	19.94	7.8168	0.9892

Table 3 T.H.D. and Power Factor at 115 Volt 60 Hz input

### 230 Volts AC Input

S.No	Output Voltage	Output Current	T.H.D	Power Factor
1	12.055	4.9975	19.936	0.9216
2	12.047	9.965	13.961	0.9659
3	12.04	14.953	13.594	0.9714
4	12.037	19.94	12.472	0.9737

Table 4 T.H.D. and Power Factor at 230 Volt 50 Hz input

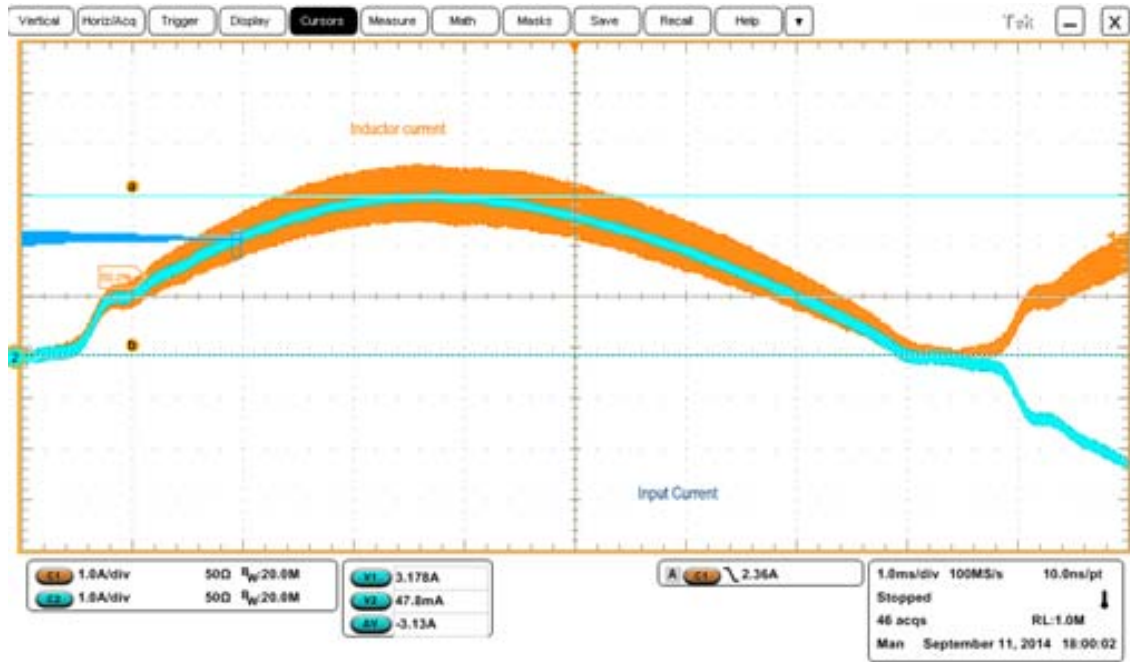

Figure 6 Inductor Current vs. Input current

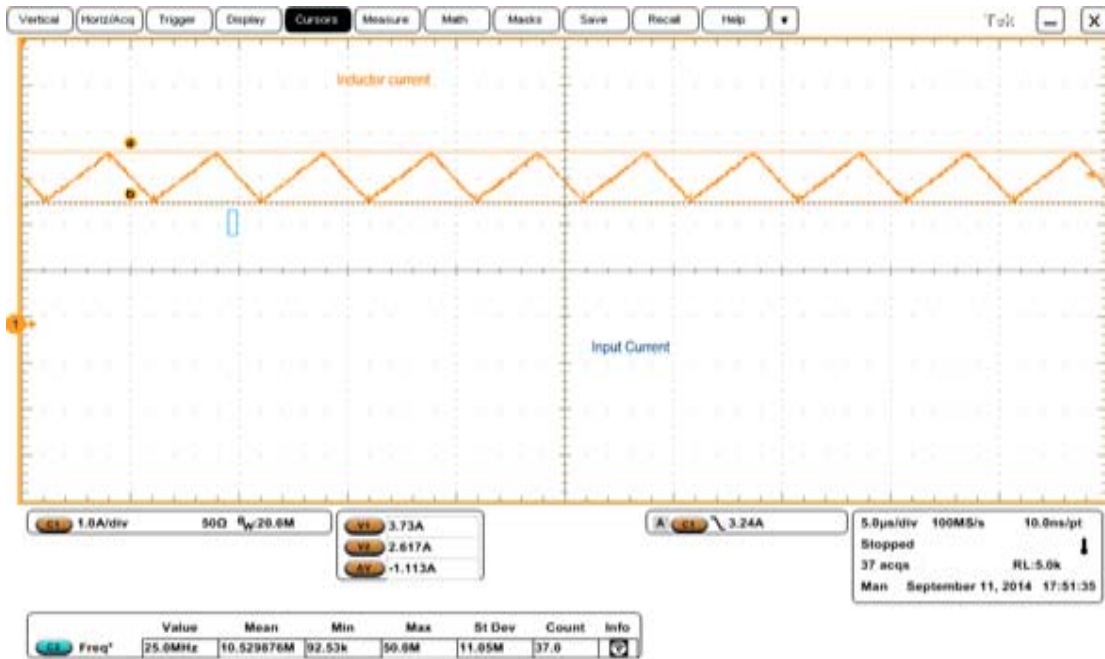

Figure 7 Inductor Current

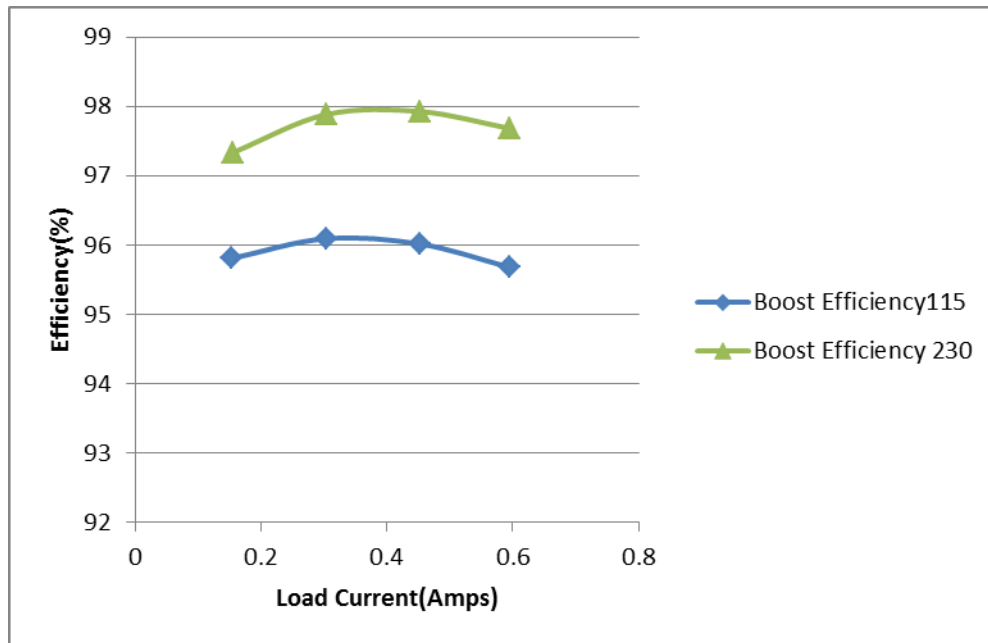

Figure 8 Boost Converter Efficiency

# LLC

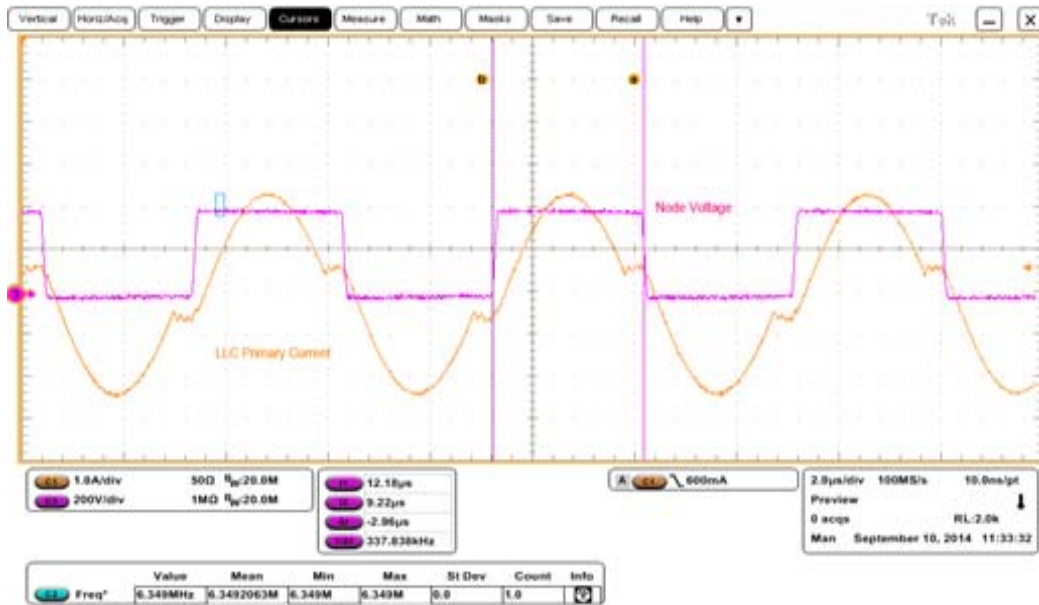

Figure 9 LLC inductor current vs node voltage (20 A load)



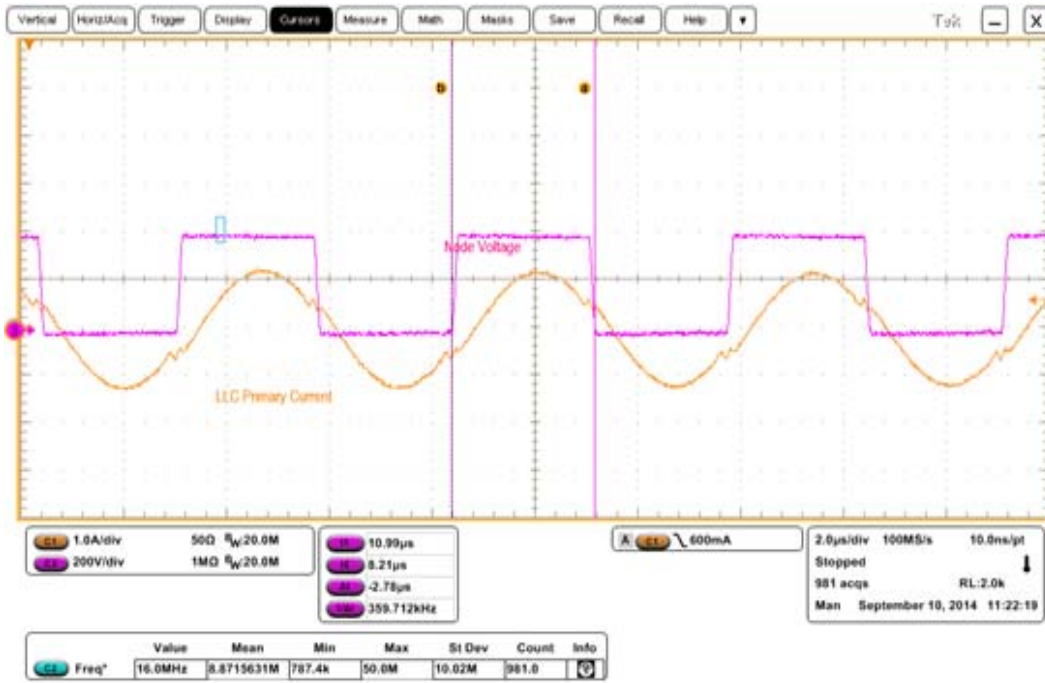

Figure 10 LLC inductor current vs node voltage (10 A load)

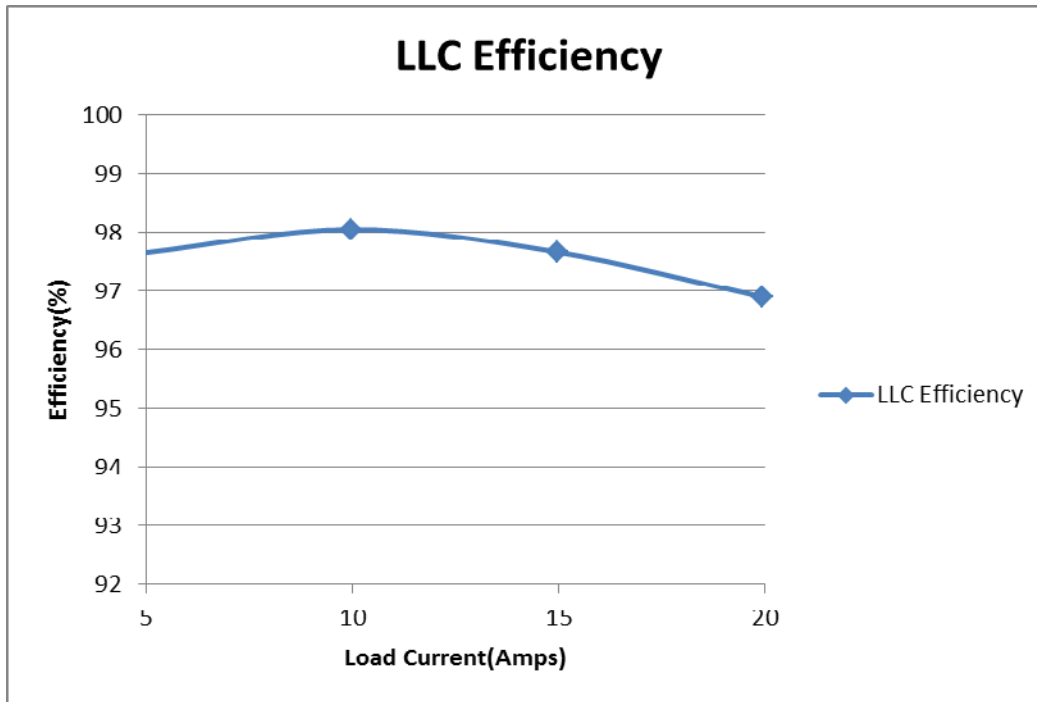

Figure 11 LLC Converter Efficiency

# Board Efficiency

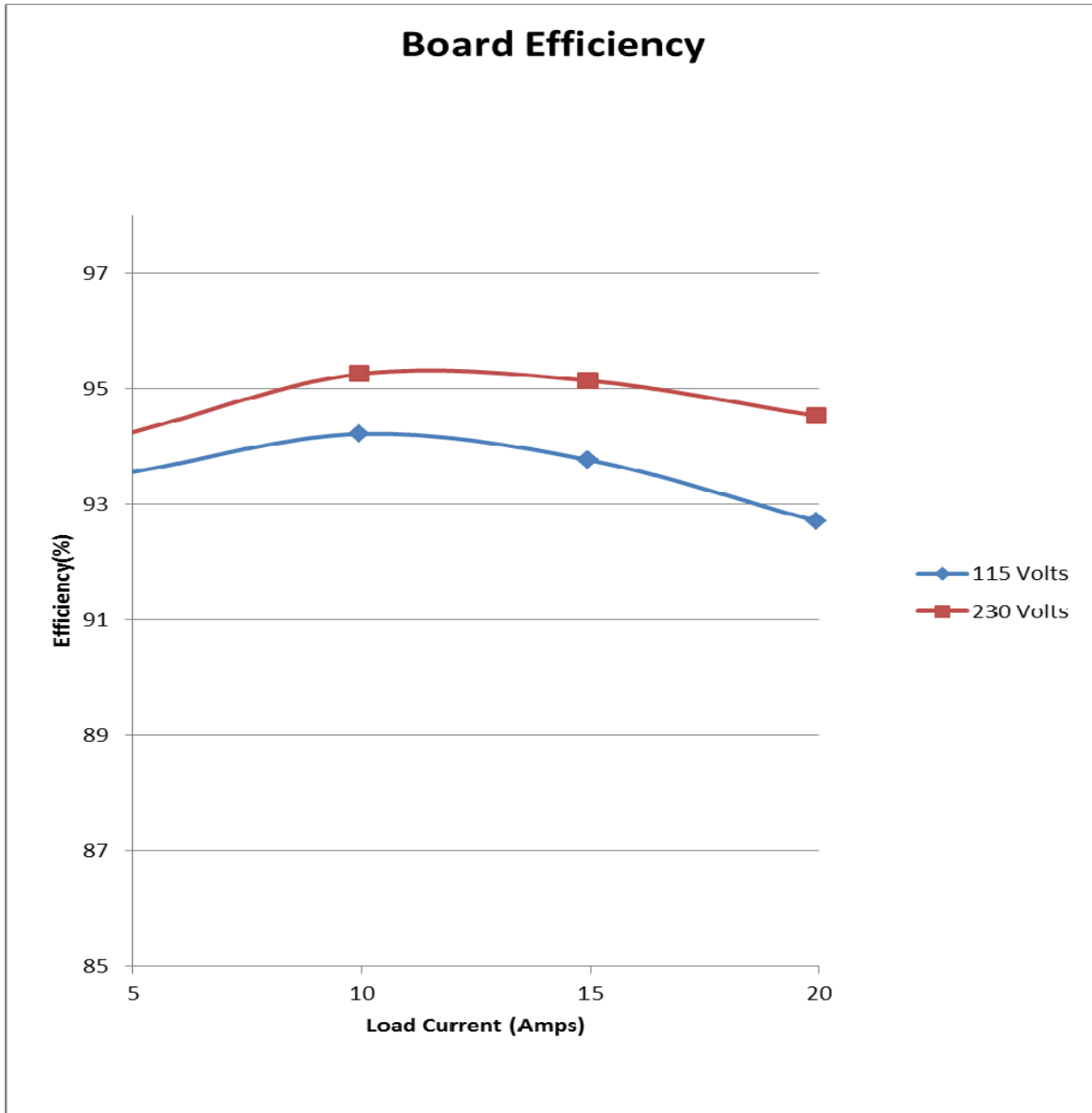
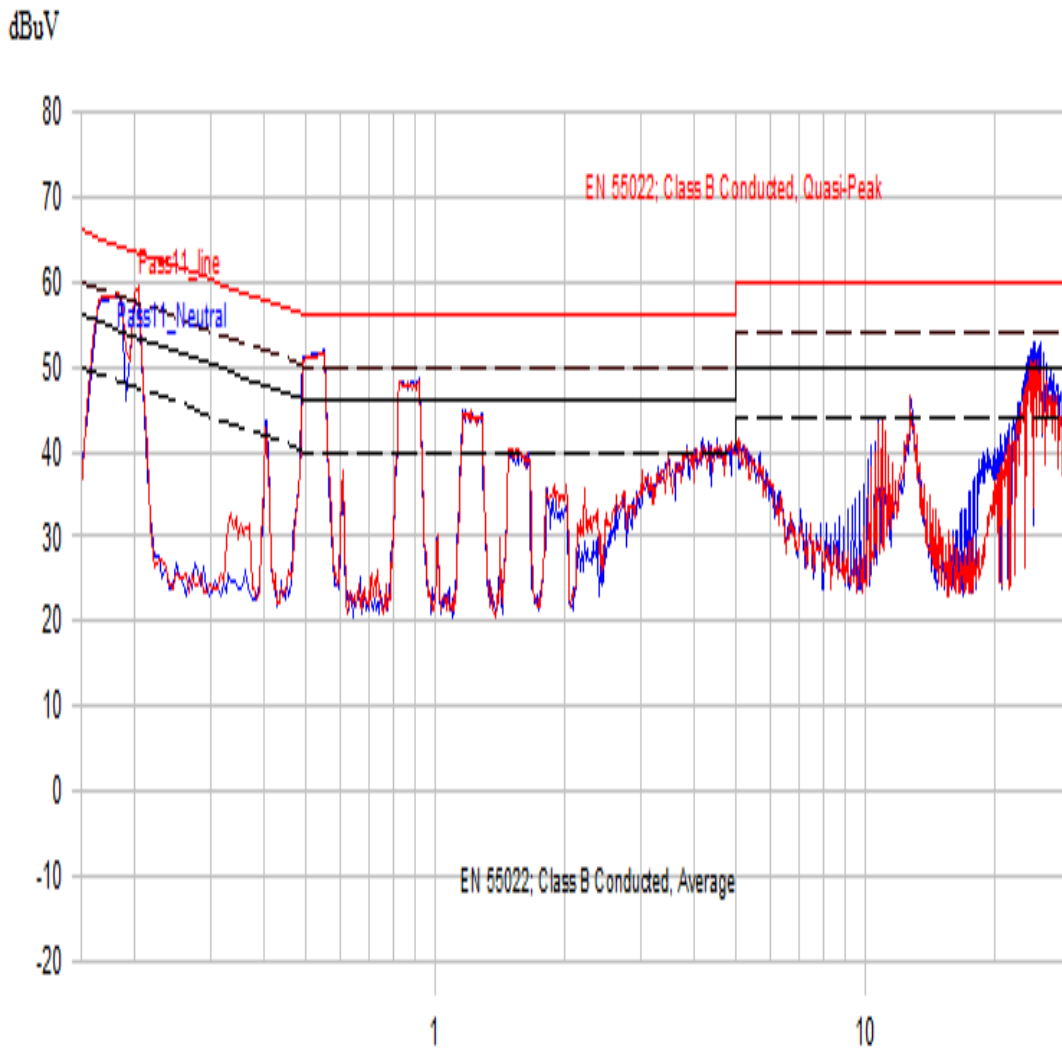

Figure 12 Complete Board Efficiency

## EMI Performance

EMI performance of the board was measured using spectrum analyzer and LISN. The board passes EN55022B standard. The results are shown below



8/18/2014 6:31:32 PM

(Start = 0.15, Stop = 30.00) MHz

Figure 13 Conducted Emission results as per EN55022

## Surge Test

The board passed surge test at 2.2 kV at common mode and 1.1 kV differential mode settings.

# Complete Schematic

Complete schematic of the board is shown in the figures below.

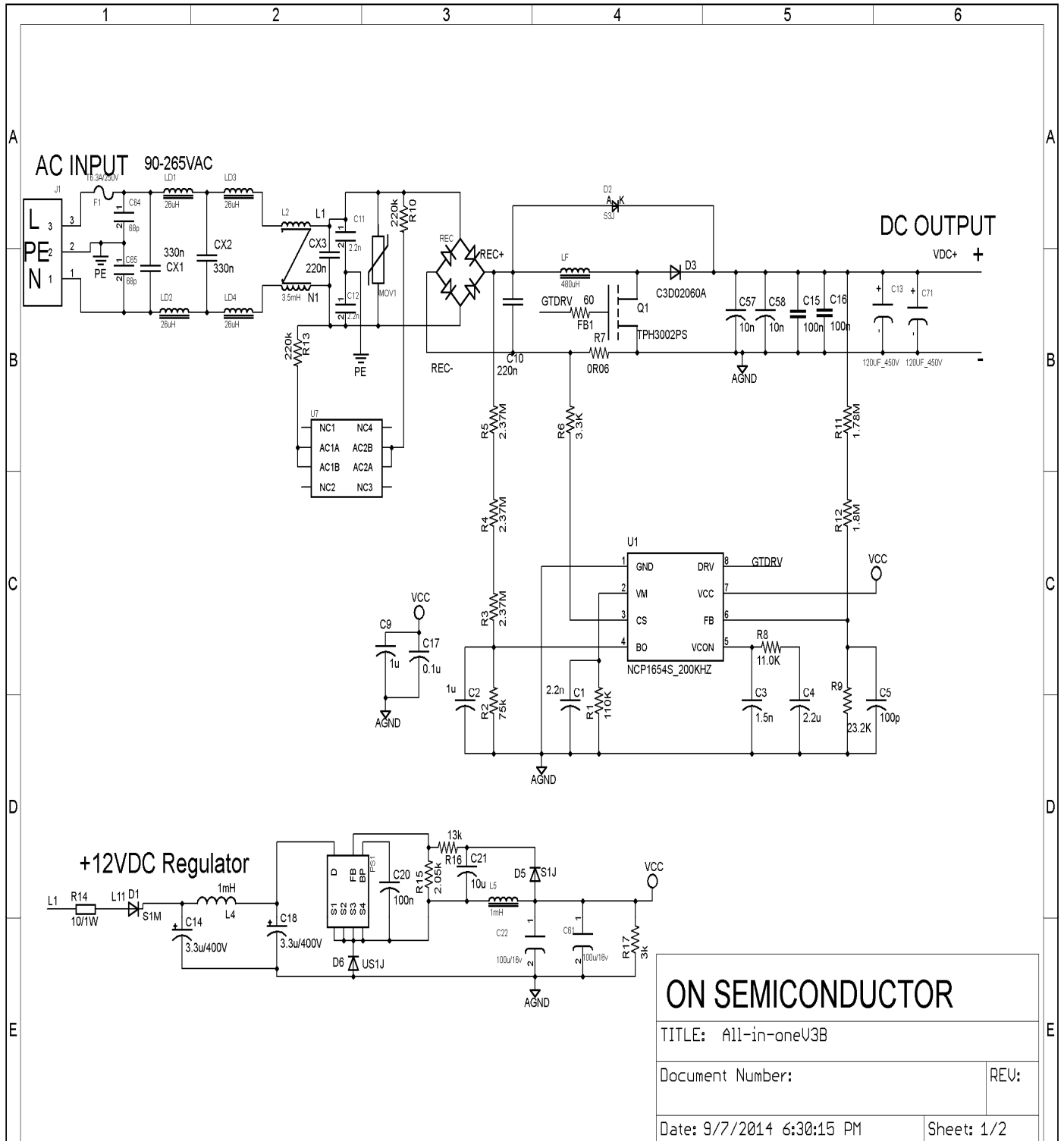
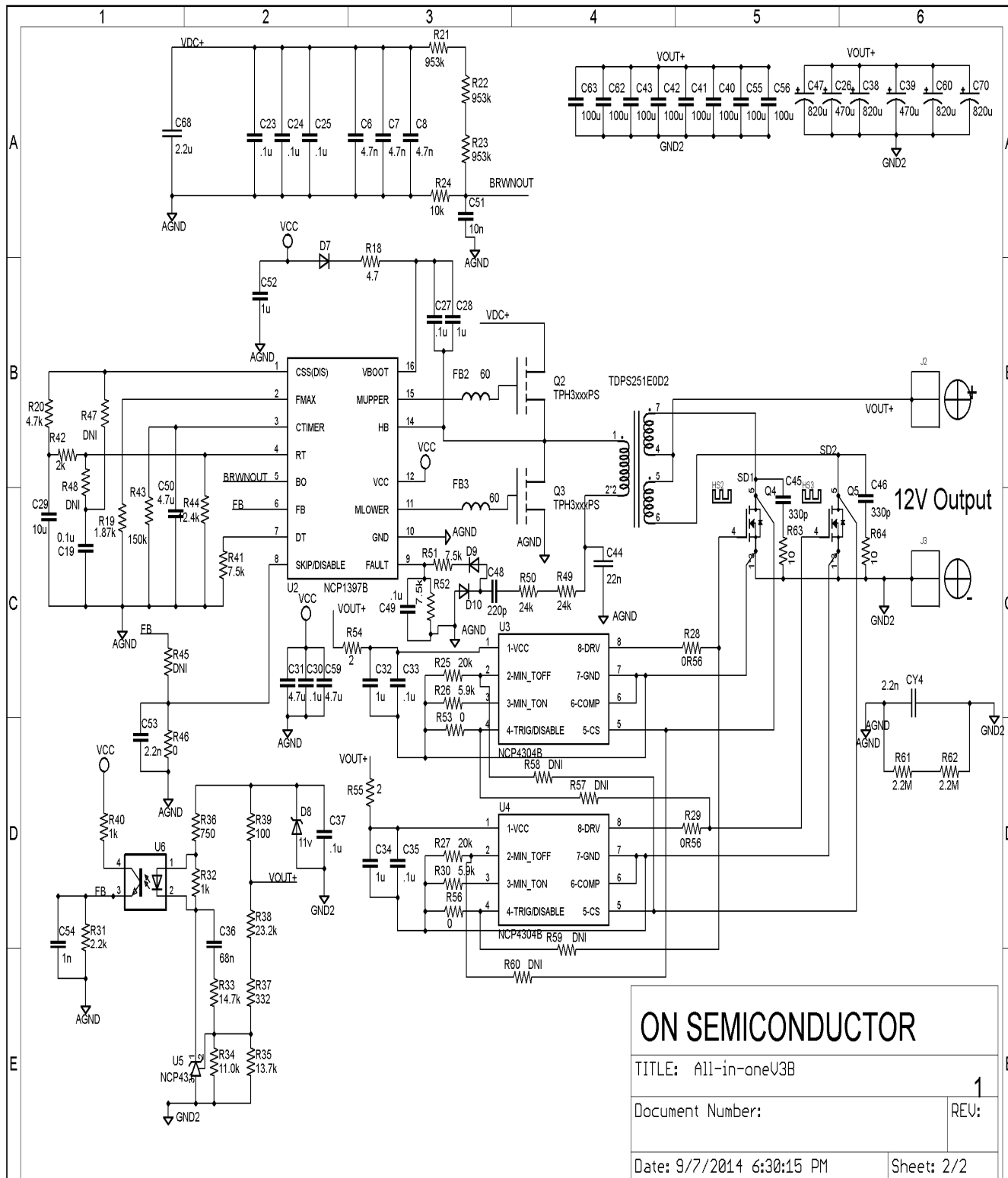

Figure 14 Complete schematic page 1

# DN05067/D



<b>ON SEMICONDUCTOR</b>	
TITLE: All-in-oneV3B	
Document Number:	1
Date: 9/7/2014 6:30:15 PM	Sheet: 2/2

Figure 15 Complete schematic page 2

## Bill of Material

Items	Qty	Reference	Part Description	Manufacture, Part No.
1	2	C1, C53	CAP., X7R, 2.2nF, 16V, 10%, 0603	AVX, 0603YC222KAT2A
2	6	C2, C9, C28, C32, C34, C52	CAP., X7R, 1μF, 16V, 10%, 0603	Taiyo Yuden, EMK107B7105KA-T
3	1	C3	CAP., X7R, 1.5nF, 16V, 10%, 0603	Kemet, C0603C152K4RACTU
4	1	C4	CAP., X5R, 2.2μF, 16V, 10%, 0603	TDK, C1608X5R1C225K080AB
5	1	C5	CAP., NP0, 100pF, 50V, 5%, 0603	AVX, C1608C0G1H101J080AA
6	3	C6, C7, C8	CAP., NP0, 4.7nF, 630V, 5%, 1206	TDK, C3216C0G2J472J085AA
7	2	C10	CAP., Film, 0.22μF, 630V, 20%, 7x15x17.5(mm)	Vishay, BFC233820224
8	3	CY1, CY2, CY4	CAP., X1Y2, 4.7nF, 250VAC, 20%, Rad.	Kemet, C947U472MYVDBA7317
9	2	C13, C71	CAP., Alum., 120μF, 450V, 20%, Rad. 18x33.5(mm)	Rubycon, 450QXW120MEFC18X31.5
10	2	C14, C18	CAP., Alum., 3.3μF, 400V, 20%, E3.5-8	Rubycon, 400LLE3R3MEFC8X11R5
11	5	C15, C16, C23, C24, C25	CAP., X7R, 0.1μF, 630V, 10%, 1812	TDK, C4532X7R2J104K230KA
12	7	C17, C19, C27, C30, C33, C35, C37	CAP., X7R, 0.1μF, 25V, 10%, 0603	Kemet, C0603C104K3RACTU
13	1	C20	CAP., X7R, 0.1μF, 25V, 10%, 1206	Kemet, C1206F104K3RACTU
14	2	C21, C29	CAP., X5R, 10μF, 16V, 20%, 0805	Kemet, C0805C106M4PACTU
15	2	C22, C61	CAP., Alum., 100μF, 16V, 20%, Rad. 5x2(mm)	Rubycon, 16PX100MEFCTA5X11
16	1	C26	CAP., Poly. Alum., 470μF, 16V, 20%, E3.5-8	Nichicon, PLG1C471MDO1
17	3	C31, C50, C59	CAP., X5R, 4.7μF, 16V, 10%, 0805	Kemet, C0805C475K4PACTU
18	1	C36	CAP., X7R, 68nF, 16V, 10%, 0603	Yageo, CC0603KRX7R7BB683
19	3	C38, C47, C70	CAP., Alum., 820μF, 16V, 20%, E5-10.5	Panasonic, EEU-FC1C821
20	1	C39	CAP., Alum., 680μF, 16V, 20%, E3.5-8	Panasonic, EEU-FC1C681L
21	8	C40, C41, C42, C43, C55, C56, C62, C63	CAP., X5R, 100μF, 16V, 20%, 1210	Taiyo Yuden, EMK325ABJ107MM-T
22	1	C44	CAP., Film, 22nF, 1kV, 5%, 26x6.5(mm)	Kemet, PHE450PD5220JR06L2
23	2	C45, C46	CAP., NP0, 330pF, 50V, 5%, 0805	Kemet, C0805C331J5GACTU
24	1	C51	CAP., X7R, 10nF, 16V, 10%, 0603	TDK, CGJ3E2X7R1C103K080AA
25	1	C54	CAP., X7R, 1nF, 16V, 5%, 0603	Kemet, C0603C102J4RACTU
26	2	C57, C58	CAP., NP0, 10nF, 630V, 5%, 1206	TDK, C3216C0G2J103J160AA
27	2	CX1, CX2	CAP., Film, 0.47 μF, 630VDC, 20%, 10x16.5x17.5(mm)	Vishay, BFC233920474
28	1	C60	CAP., Poly. Alum., 820μF, 16V, 20%, E5-10.5	Nichicon, PLG1C821MDO1
29	1	C68	CAP., Flim, 2.2μF, 450V, 5%, 18.8x12.8(mm)	Panasonic, ECW-F2W225JA
30	1	R1	RES., 110k, 0.1W, 1%, 0603	Vishay, CRCW0603110KFKEA
31	1	R2	RES., 75k, 0.1W, 5%, 0603	Vishay, CRCW060375K0JNEA
32	3	R3, R4, R5	RES., 2.37M, 1/8W, 1%, 0805	Yageo, RC0805FR-072M37L
33	2	R6, R19	RES., 3.3k, 0.1W, 1%, 0603	Stackpole, RMCF0603FT3K30
34	1	R7	RES., 60mΩ, 1W, 1%, 2512	Vishay, WSL2512R0600FEA
35	2	R8, R34	RES., 11k, 0.1W, 1%, 0603	Panasonic, ERJ-3EKF1102V

### DN05067/D

36	2	R9, R38	RES., 23.2k, 0.1W, 1%, 0603	Panasonic, ERA-3AEB2322V
37	2	R10, R13	RES., 220k, 1/4W, 1%, 1206	Yageo, RC1206FR-07220KL
38	1	R11	RES., 1.8M, 1/8W, 1%, 0805	Rohm, KTR10EZPF1804
39	1	R12	RES., 1.78M, 1/8W, 1%, 0805	Vishay, CRCW08051M78FKEA
40	1	R14	RES., 10 $\Omega$ , 1W, 1%, 2010	Stackpole, RMCP2010FT10R0
41	1	R15	RES., 2.05k, 0.1W, 1%, 0603	Yageo, RC0603FR-072K05L
42	1	R16	RES., 13k, 0.1W, 1%, 0603	Yageo, RC0603FR-0713KL
43	1	R17	RES., 13k, 1/4W, 5%, 1206	Panasonic, ERJ-8GEYJ133V
44	1	R18	RES., 4.7 $\Omega$ , 1/8W, 1%, 0805	Rohm, KTR10EZPF4R70
45	1	R20	RES., 4.7k, 0.1W, 1%, 0603	Rohm, MCR03ERTF4701
46	3	R21, R22, R23	RES., 953k, 1/8W, 1%, 0603	Panasonic, ERJ-6ENF9533V
47	1	R24	RES., 10k, 1/8W, 1%, 0805	Panasonic, ERJ-6ENF1002V
48	2	R25, R27	RES., 20k, 0.1W, 1%, 0603	Rohm, MCR03ERTF2002
49	2	R26, R30	RES., 5.9k, 0.1W, 1%, 0603	Yageo, RC0603FR-075K9L
50	2	R28, R29	RES., 0.56 $\Omega$ , 1/8W, 1%, 0805	Yageo, RL0805FR-070R56L
51	1	R31	RES., 2.2k, 0.1W, 1%, 0603	Yageo, RC0603FR-072K2L
52	3	R32, R40, R46	RES., 1k, 0.1W, 1%, 0603	Yageo, RC0603FR-071KL
53	1	R33	RES., 14.7k, 0.1W, 1%, 0603	Panasonic, ERJ-3EKF1472V
54	1	R35	RES., 13.7k, 0.1W, 1%, 0603	Panasonic, ERJ-3EKF1372V
55	1	R36	RES., 750 $\Omega$ , 0.1W, 1%, 0603	Yageo, RC0603FR-07750RL
56	1	R37	RES., 332 $\Omega$ , 0.1W, 1%, 0603	Vishay, CRCW0603332RFKEA
57	1	R39	RES., 100 $\Omega$ , 0.1W, 1%, 0603	Yageo, RC0603FR-07100RL
58	1	R41	RES., 7.5k, 0.1W, 1%, 0603	Yageo, MCR03ERTF7501
59	1	R42	RES., 2k, 0.1W, 1%, 0603	Panasonic, ERJ-3EKF2001V
60	1	R43	RES., 150k, 0.1W, 1%, 0603	Yageo, RC0603FR-07150KL
61	1	R44	RES., 12.4k, 0.1W, 1%, 0603	Yageo, RC0603FR-0712K4L
62	6	R47, R48, R57, R58, R59, R60	RES., N/A, 0603	N/A
63	1	R45	RES., 6.8k, 0.1W, 1%, 0603	Yageo, RC0603FR-076K8L
64	3	R53, R56, R52	RES., 0 $\Omega$ , 0.1W, 0603	Yageo, RC0603JR-070RL
65	2	R49, R50	RES., 24k, 1/8W, 5%, 0805	Yageo, RC0805JR-0724KL
66	2	R54, R55	RES., 4.7 $\Omega$ , 0.1W, 1%, 0603	Panasonic, P4.7AJCT-ND
67	2	R61, R62	RES., 2.2M, 1/4W, 5%, 1206	Yageo, RC1206JR-072M2L
68	2	R63, R64	RES., 10 $\Omega$ , 1/4W, 5%, 0805	Stackpole, RPC0805JT10R0
69	1	D1	Diode, 1000V, 1A, DO-214AC	Diode Inc, S1M-13-F
70	1	D2	Diode, 600V, 3A, DO-214AB	Fairchild, S3J
71	1	D3	Diode, SiC, 600V, 2A, TO220-2	Cree, C3D02060A
72	1	D5	Diode, 600V, 1A, DO-214AC	Diode Inc, S1J-13-F
73	1	D6	Diode, Ultra Fast, 600V, 1A, DO-214AC	Diode Inc, US1J-13-F
74	1	D7	Diode, Ultra Fast, 600V, 1A, DO-214AC	Micro Commercial Inc., ES1J-LTP
75	1	D8	Diode, Zener, 11V, 0.5W, SOD123	On-Semi., MMSZ5241BT1G
76	2	D9, D10	Diode, 75V, 0.15A, SOD323F	Fairchild, 1N4148WS
77	3	Q1, Q2, Q3	GaN HEMT, 600V, 9A, TO220	Transphorm, TPH3002PS
78	2	Ld1, Ld2	IND., 90 $\mu$ H, DCR<40m $\Omega$	Würth Elek., 7447013
79	1	L3	Common Mode Chk, 10mH, 1.9A, 22x15(mm)	Würth Elek., 744 824 310
80	1	L4	IND., 1mH, 70mA, 1812	Würth Elek., 744045102
81	2	Ld3, Ld4	Shorted	N/A

**DN05067/D**

82	1	L5	IND., 1mH, 0.235A, 7.6x7.6(mm)	Cooper Buss., DRA73-102-R
83	1	LF	IND., 480μH, 200kHz, CC30/19	Precision, 019-8202-00R
84	1	J1	CONN., 300V, 10A, 3Pin_3.5mm	Würth Elek., 691214110003
85	2	J2, J3	BUSH, 54A	Würth Elek., 7461093
86	2	HS2, HS3	HEATSINK, 10x10(mm)	Assmann WSW Comp., V2017B
87	1	PS1	PowerChip, Offline, 12V, 1.44W, SO-8C	Power Integ., LNK304DG-TL
88	1	MOV1	MOV, 504V, 3.5kA, Disc 10.5mm	Panasonic, ERZ-E08A561
89	1	U2	LLC Controller, 16-SOIC	On-Semi, NCP1397BDR2G
90	1	U1	PFC Controller, CCM, 200kHz, SO-08	On-Semi, NCP1654BD200R2G
91	2	U3,U4	Synchronous Rectifier Driver, SO-08	On-Semi, NCP4304BDR2G
92	1	U5	Voltage Reference, SOT23	On-Semi, NCP432BCSNT1G
93	1	U6	Optoisolator, 5kV, 4-SMD	Avargo, HCPL-817-50AE
94	1	U7	X2 CAP. DIS., SOIC-8	On-Semi, NCP4810DR2G
95	1	F1	FUSE, SLOW, 250V, 6.3A	Littlefuse Inc, 39216300000
96	2	Q4, Q5	MOSFET, N-CH, 40V, 100A, PG-TDSON-8	Infineon, BSC017N04NS G
97	1	Transformer	Transformer, LLC, 240W, 170kHz – 200kHz	Precision, 019-7896-00R
98	3	FB1, FB2, FB3	Ferrite Bead, 60Ω@100MHz, 500mA, 0603	TDK, MMZ1608Y600B
99	1	REC	Rectifier Bridge, 600V, 8A, D-72	Vishay, VS-KBPC806PBF
100	1	N/A	Thermal Pad, 0.9W/m-K, 18.42x13.21(mm)	Aavid Thermalloy, 53-77-9G
101	1	N/A	Ferrite Core, 47Ω@100MHz, 4.2mm OD	Würth Elek., 74270012

Table 5 Bill of Material

**Startup sequence:**

1. Connect a load. The load should be resistive, and maximum of 240watt at 12Vdc;
2. Connect an AC power source, set to the desired voltage higher than 90V.
3. Place a cooling fan facing the GaN HEMTs heat sink of PFC (provide a minimum of 30 CFM air flow).
4. Turn on the cooling fan if output power is higher than 155W (>70% Load);

**Probing Instructions:**

In order to minimize additional inductance during measurement, the tip and the ground of the probe should be directly attached to the sensing points to minimize the sensing loop; while the typical long ground lead should be avoided since it will form a sensing loop and could pick up the noise. The differential probes are not recommended for the GaN signal measurement.



## References:

- [1]. Datasheet of NCP1654, website: [www.onsemi.com](http://www.onsemi.com), On Semiconductor.
- [2]. Datasheet of NCP1397, website: [www.onsemi.com](http://www.onsemi.com), On Semiconductor.
- [3]. Datasheet of NCP4304, website: [www.onsemi.com](http://www.onsemi.com), On Semiconductor.
- [4]. AND8324-D Application Note, website: [www.onsemi.com](http://www.onsemi.com), On Semiconductor.
- [5]. Bo Yang, F.C. Lee, A.J. Zhang, H. Guisong, "LLC resonant converter for front end DC/DC conversion" *Proc. IEEE APEC'02*, pp.1108 – 1112, 2002.
- [6]. Application Note. TDPS250E2D2 All in One Power Supply, website: [www.transphormusa.com](http://www.transphormusa.com), Transphorm Inc.
- [7] Datasheet of TPH3002PS, website [www.transphorm.com](http://www.transphorm.com)

© 2014 ON Semiconductor.

**Disclaimer:** ON Semiconductor is providing this design note "AS IS" and does not assume any liability arising from its use; nor does ON Semiconductor convey any license to its or any third party's intellectual property rights. This document is provided only to assist customers in evaluation of the referenced circuit implementation and the recipient assumes all liability and risk associated with its use, including, but not limited to, compliance with all regulatory standards. ON Semiconductor may change any of its products at any time, without notice.

**DN05067/D**

*Design note created by Tim Kaske, e-mail: [Tim.Kaske@onsemi.com](mailto:Tim.Kaske@onsemi.com)*

Компания «Океан Электроники» предлагает заключение долгосрочных отношений при поставках импортных электронных компонентов на взаимовыгодных условиях!

Наши преимущества:

- Поставка оригинальных импортных электронных компонентов напрямую с производств Америки, Европы и Азии, а так же с крупнейших складов мира;
- Широкая линейка поставок активных и пассивных импортных электронных компонентов (более 30 млн. наименований);
- Поставка сложных, дефицитных, либо снятых с производства позиций;
- Оперативные сроки поставки под заказ (от 5 рабочих дней);
- Экспресс доставка в любую точку России;
- Помощь Конструкторского Отдела и консультации квалифицированных инженеров;
- Техническая поддержка проекта, помощь в подборе аналогов, поставка прототипов;
- Поставка электронных компонентов под контролем ВП;
- Система менеджмента качества сертифицирована по Международному стандарту ISO 9001;
- При необходимости вся продукция военного и аэрокосмического назначения проходит испытания и сертификацию в лаборатории (по согласованию с заказчиком);
- Поставка специализированных компонентов военного и аэрокосмического уровня качества (Xilinx, Altera, Analog Devices, Intersil, Interpoint, Microsemi, Actel, Aeroflex, Peregrine, VPT, Syfer, Eurofarad, Texas Instruments, MS Kennedy, Miteq, Cobham, E2V, MA-COM, Hittite, Mini-Circuits, General Dynamics и др.);

Компания «Океан Электроники» является официальным дистрибьютором и эксклюзивным представителем в России одного из крупнейших производителей разъемов военного и аэрокосмического назначения «JONHON», а так же официальным дистрибьютором и эксклюзивным представителем в России производителя высокотехнологичных и надежных решений для передачи СВЧ сигналов «FORSTAR».



## JONHON

«JONHON» (основан в 1970 г.)

Разъемы специального, военного и аэрокосмического назначения:

(Применяются в военной, авиационной, аэрокосмической, морской, железнодорожной, горно- и нефтедобывающей отраслях промышленности)

«FORSTAR» (основан в 1998 г.)

ВЧ соединители, коаксиальные кабели, кабельные сборки и микроволновые компоненты:

(Применяются в телекоммуникациях гражданского и специального назначения, в средствах связи, РЛС, а так же военной, авиационной и аэрокосмической отраслях промышленности).



Телефон: 8 (812) 309-75-97 (многоканальный)

Факс: 8 (812) 320-03-32

Электронная почта: [ocean@oceanchips.ru](mailto:ocean@oceanchips.ru)

Web: <http://oceanchips.ru/>

Адрес: 198099, г. Санкт-Петербург, ул. Калинина, д. 2, корп. 4, лит. А