

DESCRIPTION

The MP3313 is a step-up, white, LED converter. The MP3313 uses peak-current mode and a 3-channel current sink to regulate the LED current with up to 25mA on each channel (100mA at flash mode) with 2.7 - 5.5V input voltage.

The MP3313 integrates a 300mΩ, 42V MOSFET and supports selectable over-voltage protection (17/23/30/38V). The MP3313 can drive up to 10 LEDs in series for LCD panels greater than 5".

The MP3313 achieves ultra-high resolution analog dimming by converting the pulse-width input signal or internal register code to an 11-bit brightness code. The MP3313 is designed with two types of LED current dimming mapping: linear and exponential mapping.

An auto-switching frequency function is integrated to optimize efficiency performance. Full protection features include LED open and short protection, cycle-by-cycle current-limit protection, and thermal shutdown.

The I²C interface can set the internal register to program the MP3313 for flexible applications, such as dimming mode, LED current slope, and protection threshold.

The MP3313 is available in a small WLCSP-12 (1.3mmx1.7mm) package.

FEATURES

- 2.7 - 5.5V Input Voltage
- 300mΩ, 42V Internal MOSFET
- 3-Channel Current Sink, Each Channel Enable/Disable Respectively
- LED Current up to 25mA in Backlighting Mode
- LED Current up to 100mA in Flash Mode
- 250μA - 25mA LED Current with ±3% Accuracy
- ±1% Typical Current Matching
- Linear or Exponential Analog Dimming
- 11-Bit Dimming Resolution
- Selectable Switching Frequency: 500kHz or 1MHz with Optional -12% Shift
- Auto-Switching Frequency (250kHz, 500kHz, 1MHz)
- High-Speed I²C Interface (1.2MHz)
- I²C Address External Selectable (A0 Pin)
- Internal Soft Start (SS) to Reduce Inrush Current
- Current-Limit Protection (0.75/1/1.25/1.5A)
- LED Open Protection (17/23/30/38V)
- LED Short Protection (2/3/5V)
- Available in a WLCSP-12 (1.3mmx1.7mm) Package

APPLICATIONS

- Smart Phones
- Tablets
- GPS Receivers
- LCD Video Displays with One-Cell Li-Ion Battery

All MPS parts are lead-free, halogen-free, and adhere to the RoHS directive. For MPS green status, please visit the MPS website under Quality Assurance. "MPS" and "The Future of Analog IC Technology" are registered trademarks of Monolithic Power Systems, Inc.

TYPICAL APPLICATION

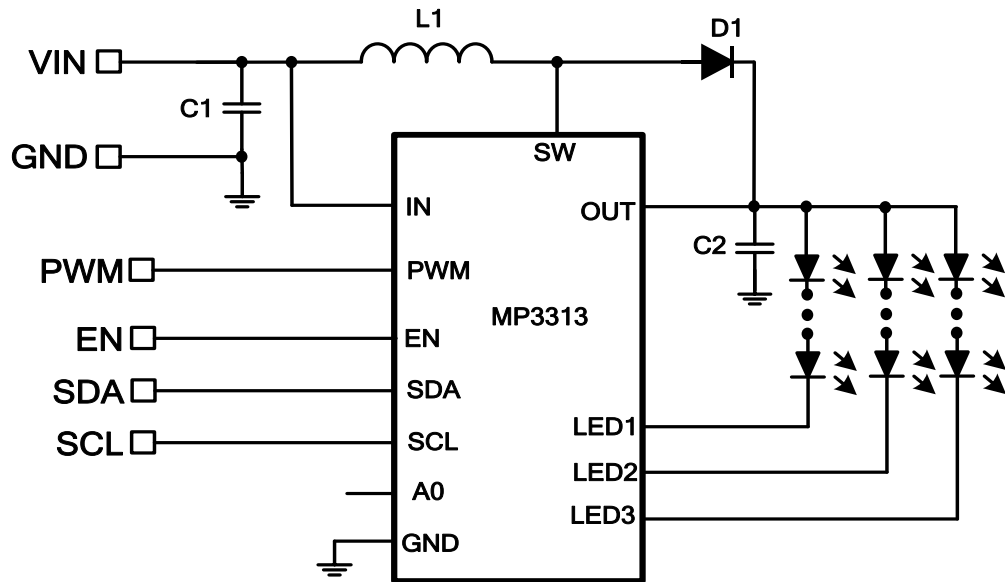

ORDERING INFORMATION

Part Number*	Package	Top Marking
MP3313GC	WLCSP-12 (1.3mmx1.7mm)	See Below

* For Tape & Reel, add suffix -Z (e.g. MP3313GC-Z)

TOP MARKING

—
GAY
LLL

GA: Product code of MP3313GC
 Y: Year code
 LLL: Lot number

PACKAGE REFERENCE

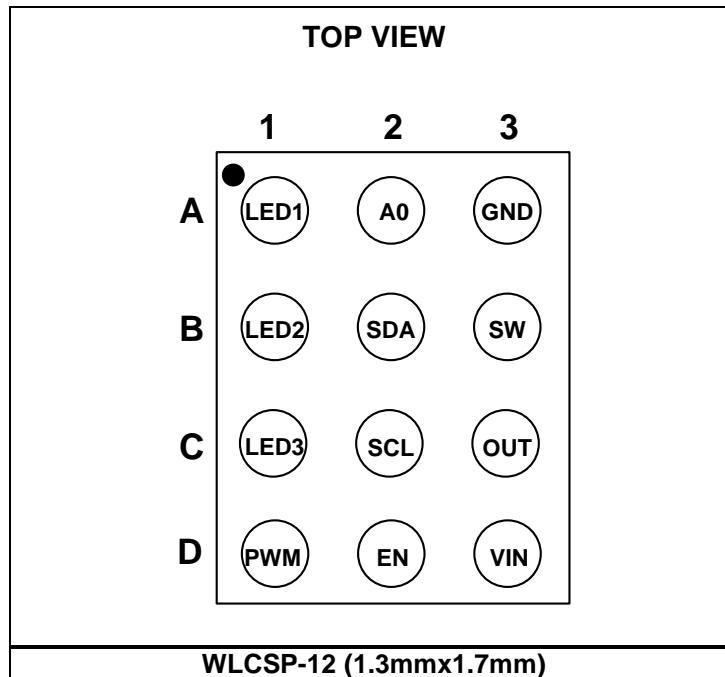

ABSOLUTE MAXIMUM RATINGS ⁽¹⁾

V _{IN}	-0.3V to +6V
V _{SW}	-1V to +42V
V _{LED1~3}	-0.3V to +40V
V _{OUT}	-1V to +40V
All other pins.....	-0.3V to +5.3V
Junction temperature	150°C
Lead temperature	260°C
Continuous power dissipation (T _A = 25°C) ⁽²⁾	
WLCSP-12 (1.3mmx1.7mm).....	1.14W

Recommended Operating Conditions ⁽³⁾

Supply voltage (V _{IN}).....	2.7V to 5.5V
Operating junction temp. (T _J) ...	-40°C to +125°C

Thermal Resistance ⁽⁴⁾	θ_{JA}	θ_{JC}
WLCSP-12 (1.3mmx1.7mm) ...	110 ...	12 ... °C/W

NOTE:

- 1) Exceeding these ratings may damage the device.
- 2) The maximum allowable power dissipation is a function of the maximum junction temperature T_J (MAX), the junction-to-ambient thermal resistance θ_{JA}, and the ambient temperature T_A. The maximum allowable continuous power dissipation at any ambient temperature is calculated by P_D (MAX) = (T_J (MAX)-T_A)/θ_{JA}. Exceeding the maximum allowable power dissipation produces an excessive die temperature, causing the regulator to go into thermal shutdown. Internal thermal shutdown circuitry protects the device from permanent damage.
- 3) The device is not guaranteed to function outside of its operating conditions.
- 4) Measured on JESD51-7, 4-layer PCB.

ELECTRICAL CHARACTERISTICS

V_{IN} = 3.6V, V_{EN} = V_{PWM} = high, typical values are at T_A = 25°C, unless otherwise noted.

Parameters	Symbol	Condition	Min	Typ	Max	Unit
Power Supply						
Operating input voltage	V _{IN}		2.7		5.5	V
Supply current (quiescent)	I _Q	V _{IN} = 3.6V, V _{EN} = V _{PWM} = high, no switching, I ² C active		2.4	2.7	mA
Supply current (shutdown)	I _{ST}	V _{EN} = 0V, V _{IN} = 3.6V			1	μA
Input UVLO threshold	V _{IN_UVLO}	Rising edge		2.4	2.6	V
Input UVLO hysteresis				200		mV
Oscillator						
Switching frequency	f _{SW}	FS bit = 1	950	1000	1050	kHz
		FS bit = 0	475	500	525	kHz
Maximum duty cycle	D _{MAX}	F _{SW} = 500kHz	93	95		%
		F _{SW} = 1.0MHz	90	93		%
Minimum on time	T _{ON_MIN}			100		ns
Power Switch						
Switch on resistance	R _{DS(on)}	V _{IN} = 3.6V		300		mΩ
Current Regulation						
Minimum output current	I _{LED_min}	Linear/exponential mode		50		μA
Maximum output current	I _{LED_max}	Linear/exponential mode		25		mA
LEDx regulation voltage	V _{REG}	I _{LED} = 25mA		220		mV
		I _{LED} = 5mA		130		mV
Current accuracy		I _{LED} = 250μA - 25mA, 2.7 - 5V, linear/exponential dimming	-3	0.1	3	%
Current matching ⁽⁵⁾		I _{LED} = 5 - 25mA, 2.7 - 5V, linear/exponential dimming	-1	0.1	1	%
		I _{LED} = 250μA - 5mA, 2.7 - 5V, linear/exponential dimming	-1	0.1	2	%
EN and PWM Logic						
PWM input low threshold	V _{PWM_LO}	V _{PWM} falling			0.4	V
PWM input high threshold	V _{PWM_HI}	V _{PWM} rising	1.2			V
EN low voltage	V _{EN_LOW}	V _{EN} falling			0.4	V
EN high voltage	V _{EN_HIGH}	V _{EN} rising	1.2			V
EN and PWM pull-down resistor	R _{PD}			1		MΩ

ELECTRICAL CHARACTERISTICS (continued)
V_{IN} = 3.6V, V_{EN} = V_{PWM} = high, typical values are at T_A = 25°C, unless otherwise noted.

Parameters	Symbol	Condition	Min	Typ	Max	Unit
Protection						
OVP voltage	V _{OVP}	OVP1:0 bit = 00	16	17	18	V
		OVP1:0 bit = 01	22	23	24	V
		OVP1:0 bit = 10	29	30	31	V
		OVP1:0 bit = 11	37	38	39	V
OUT under-voltage protection	V _{OUT_UV}		1.2		V	
Cycle-cycle current limit	I _{LIM}	OCP1:0 bit = 00	0.6	0.75	0.9	A
		OCP1:0 bit = 01	0.8	1	1.2	A
		OCP1:0 bit = 10	1.0	1.25	1.5	A
		OCP1:0 bit = 11	1.2	1.5	1.8	A
LEDX over-voltage threshold	V _{OVP_LED}		4.5	5	5.5	V
LEDX under-voltage threshold	V _{LEDX_UV}			40		mV
Thermal shutdown threshold	T _{ST}			150		°C
Thermal shutdown hysteresis				25		°C
PWM Input ⁽⁶⁾						
Minimum PWM frequency	F _{PWML}				50	Hz
Maximum PWM frequency	F _{PWMH}	24MHz sample rate	50			kHz
Minimum on time	T _{MIN_ON}	24MHz sample rate			183.3	ns
		4MHz sample rate			1100	ns
		800kHz sample rate			5500	ns
Minimum off time	T _{MIN_OFF}	24MHz sample rate			183.3	ns
		4MHz sample rate			1100	ns
		800kHz sample rate			5500	ns
PWM shutdown time	T _{PWM_SD}	24MHz sample rate		0.6		ms
		4MHz sample rate		3		ms
		800kHz sample rate		25		ms
PWM input glitch rejection	T _{GLITCH}	FILTER1:0 bit = 01		80		ns
		FILTER1:0 bit = 10		160		ns
		FILTER1:0 bit = 11		240		ns
Delay time at power-on	T _{POWERON}	EN power-on to start switching		3.5	5	ms

ELECTRICAL CHARACTERISTICS (continued)
V_{IN} = 3.6V, V_{EN} = V_{PWM} = high, typical values are at T_A = 25°C, unless otherwise noted.

Parameters	Symbol	Condition	Min	Typ	Max	Unit
I²C Interface						
Input logic low	V _{IL}				0.4	V
Input logic high	V _{IH}		1.3			V
Output logic low	V _{OL}	I _{LOAD} = 3mA			0.4	V
SCLH clock frequency	f _{SCL}				1200	kHz
Set-up time for (repeated) start condition	t _{SU,STA}		160			ns
Hold time for (repeated) start condition	t _{HD,STA}		160			ns
Low time for SCLH clock	t _{LOW}		160			ns
High time for SCLH clock	t _{HIGH}		60			ns
Data set-up time	t _{SU,DAT}		10			ns
Data hold time	t _{HD,DAT}		0 ⁽⁷⁾		70	ns
Rise time of SCLH clock	t _{R,SCL}		10		40	ns
Rise time of SCLH clock after repeated start and acknowledge bit	t _{R,SCL1}		10		80	ns
Fall time of SCLH clock	t _{F,SCL}		10		40	ns
Rise time of SDAH data	t _{R,SDA}		10		80	ns
Fall time of SDAH data	t _{F,SDA}		10		80	ns
Set-up time for stop condition	t _{SU,STO}		160			ns
Capacitive load for SDAH line and SCLH line	C _B ⁽⁸⁾				100	pF
Capacitive load for SDAH+SDA line and SCLH+SCL line	C _B				400	pF

NOTES:

- 5) Matching is defined as the difference of the maximum to minimum current divided by 2 times average currents.
- 6) Guaranteed by design.
- 7) A device must provide a data hold time internally to bridge the undefined part between V_{IL} and V_{IH} of the falling edge of the SCLH signal. An input circuit with a threshold as low as possible for the falling edge of SCLH signal minimizes the hold time.
- 8) For the bus line-load C_B between 100pF and 400pF, the timing parameters must be increased linearly.

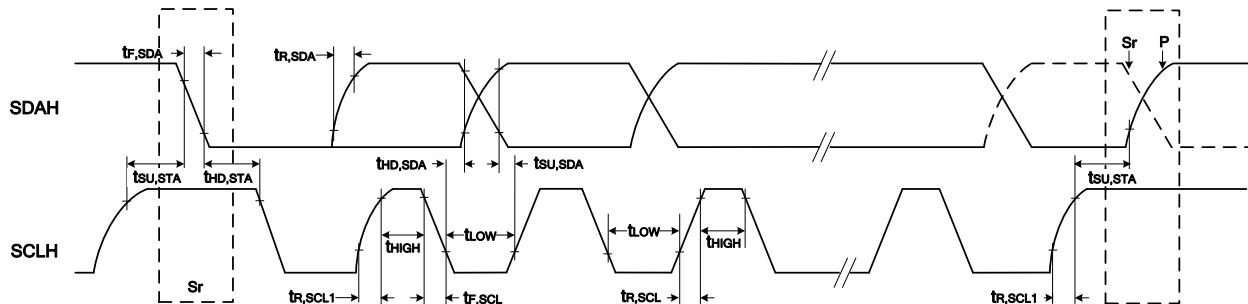

Sr: Repeated START Condition
P: STOP Condition

I²C-Compatible Interface Timing Diagram

TYPICAL PERFORMANCE CHARACTERISTICS

V_{IN} = 3.6V, 8*LEDs/string, I_{LED/Ch} = 20mA, L = 10μH, T_A = 25°C, unless otherwise noted.

LED Current for Each Channel with Register Code

Current Curve (Dimming by Code only)

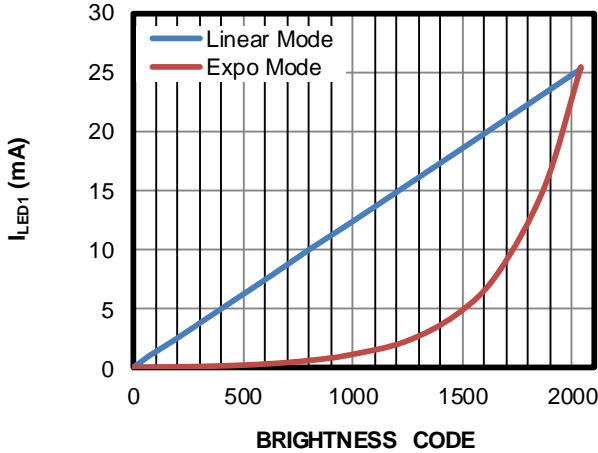

LED Current for Each Channel with PWM Input Duty

Current Curve (Dimming by PWM only)

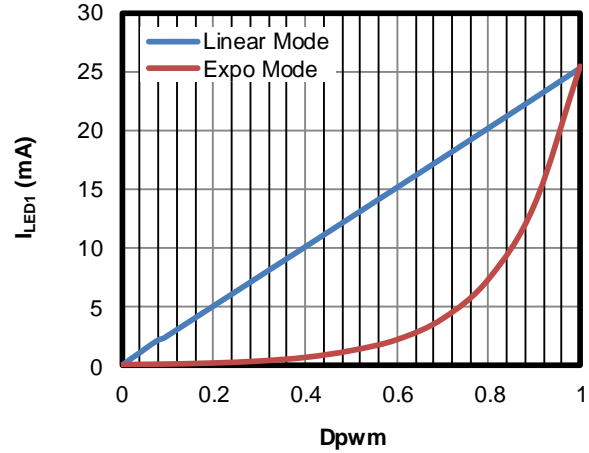

Efficiency Curve E-I_{OUT}

1MHz, 10μH, DCR = 49mΩ

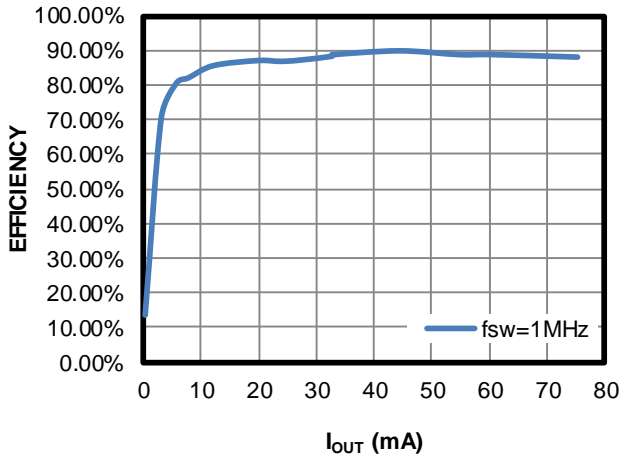

Efficiency Curve E-I_{OUT}

500kHz, 10μH, DCR = 49mΩ

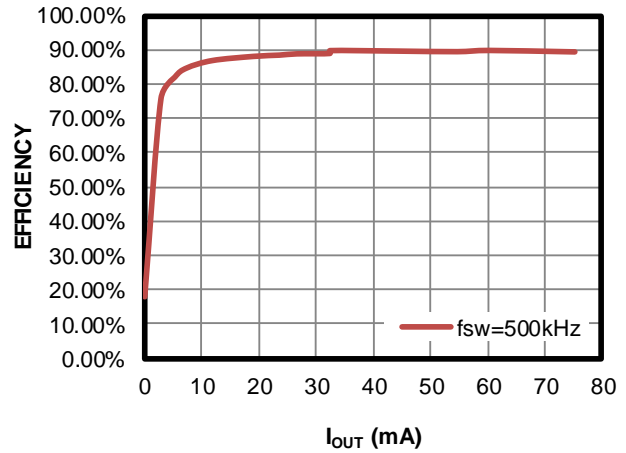

Efficiency Curve E-V_{IN}

10μH, DCR = 49mΩ

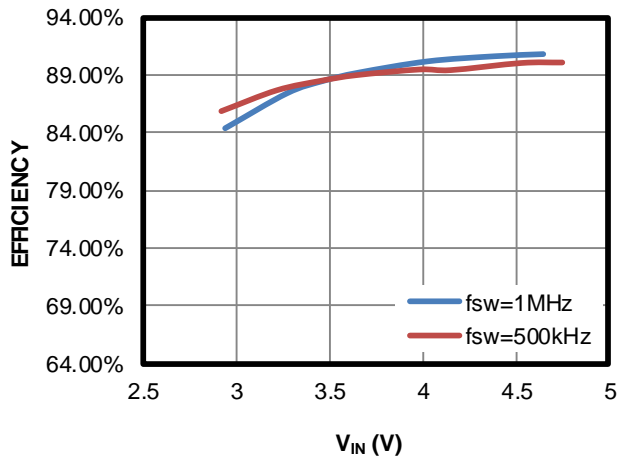

LEDx Voltage vs. LED Current

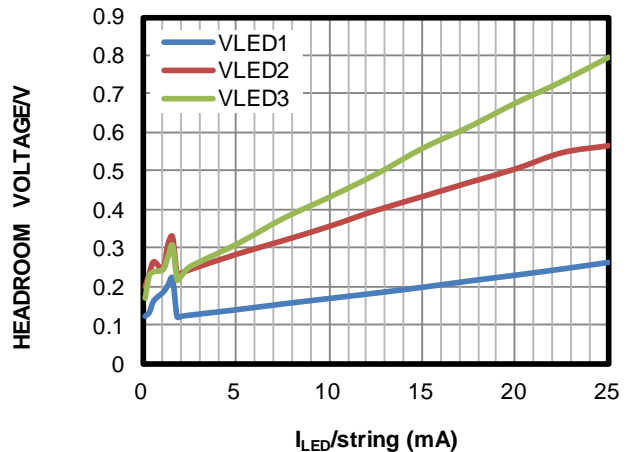

TYPICAL PERFORMANCE CHARACTERISTICS *(continued)*

V_{IN} = 3.6V, 8*LEDs/string, I_{LED/Ch} = 20mA, L = 10μH, T_A = 25°C, unless otherwise noted.

Steady State

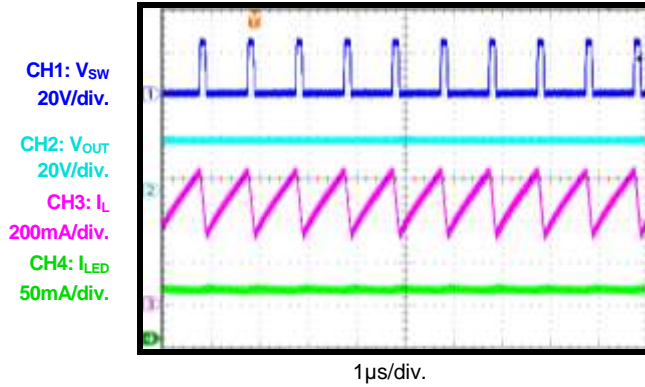

EN Power-On

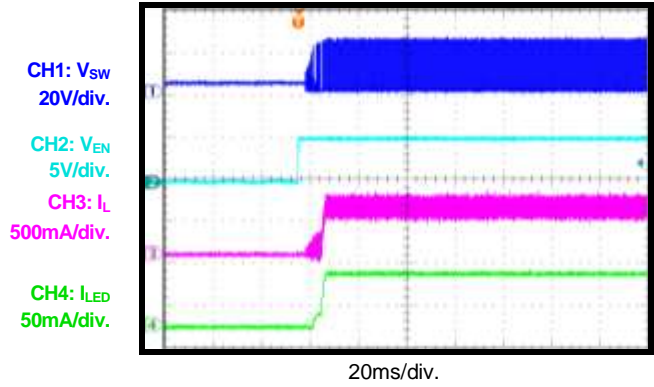

VIN Power On

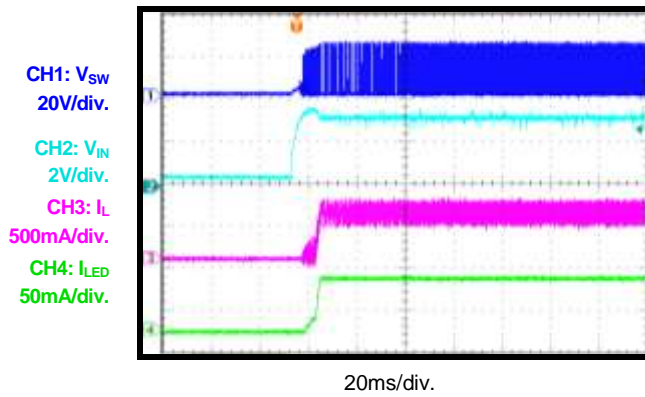

Flash Mode

Flash Time = 300ms, Flash Current = 40mA/ch

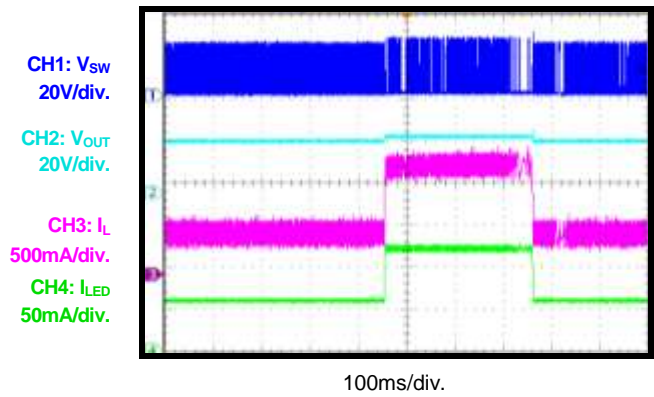

Short LED Protection (Mark Off)

Short one string

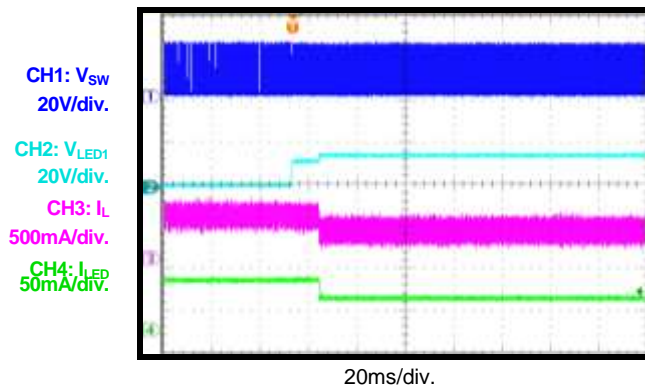

Short LED Protection (IC Latch Off)

Short LED1 String

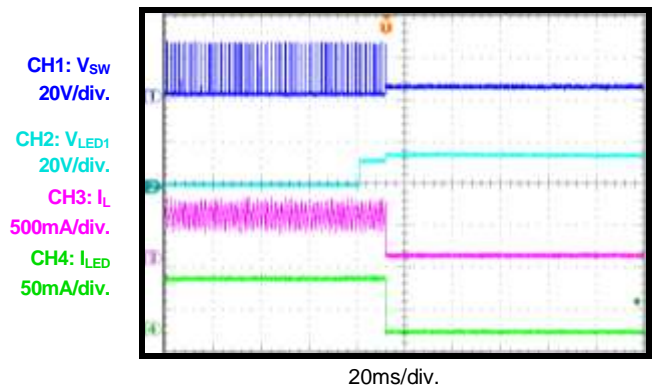

TYPICAL PERFORMANCE CHARACTERISTICS *(continued)*

V_{IN} = 3.6V, 8*LEDs/string, I_{LED/Ch} = 20mA, L = 10μH, T_A = 25°C, unless otherwise noted.

Open LED Protection (Mark Off)

V_{OVP} = 30V, Open 1 String

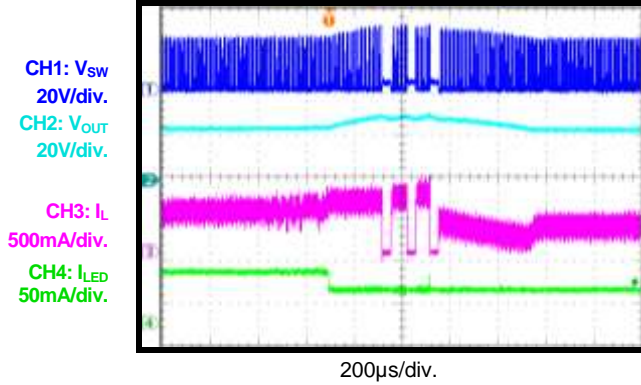

Open LED Protection (IC latch Off)

V_{OVP} = 30V, Open 1 String

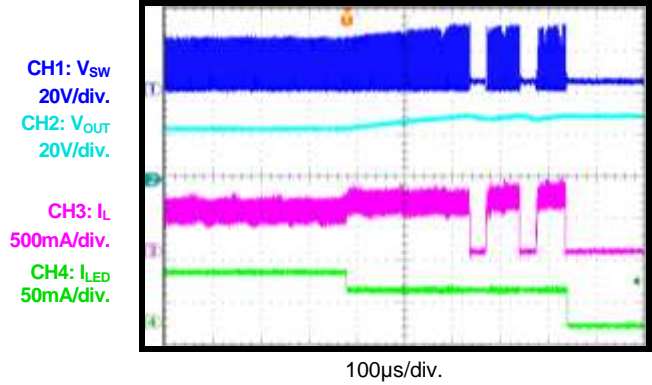

Thermal Shutdown Protection (IC Latch Off)

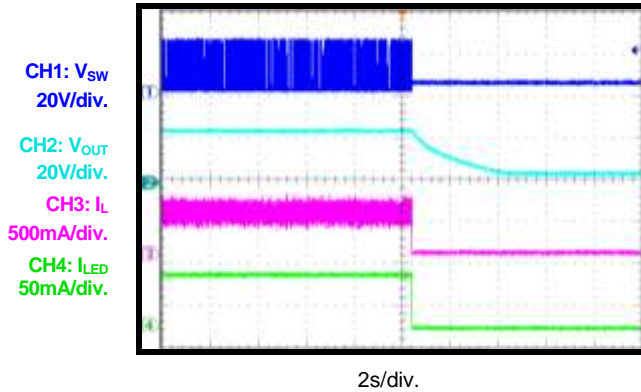

Thermal Shutdown Protection (Recoverable)

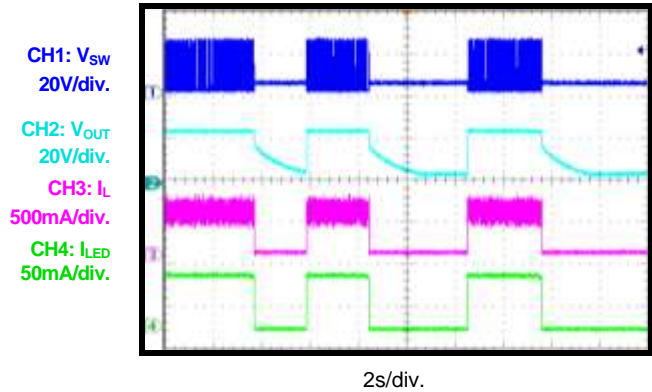

PIN FUNCTIONS

Pin #	Name	I/O	Description
A1	LED1	I	Current sink for LED1.
A2	A0	I	LSB of I²C interface address select. If A0 is floating, it must be pulled up or down externally. If A0 is pulled low, the I ² C address LSB is 0. If A0 is pulled high, the I ² C address LSB is 1.
A3	GND	I	Ground.
B1	LED2	I	Current sink for LED2.
B2	SDA	I/O	I²C interface data signal input.
B3	SW	I	Drain connection of the internal low-side MOSFET for boost converter.
C1	LED3	I	Current sink for LED3.
C2	SCL	I	I²C interface clock signal input.
C3	OUT	O	Boost converter output connection.
D1	PWM	I	PWM dimming input signal. Apply a 50Hz to 50kHz PWM pulse to the PWM pin for analog dimming.
D2	EN	I	IC enable input. Drive EN to logic high to enable the IC. Drive EN to logic low longer than 2.5ms to shut down the IC.
D3	VIN	I	Power supply input with 2.7V to 5.5V. Connect a ceramic capacitor close to VIN to bypass the IC.

BLOCK DIAGRAM

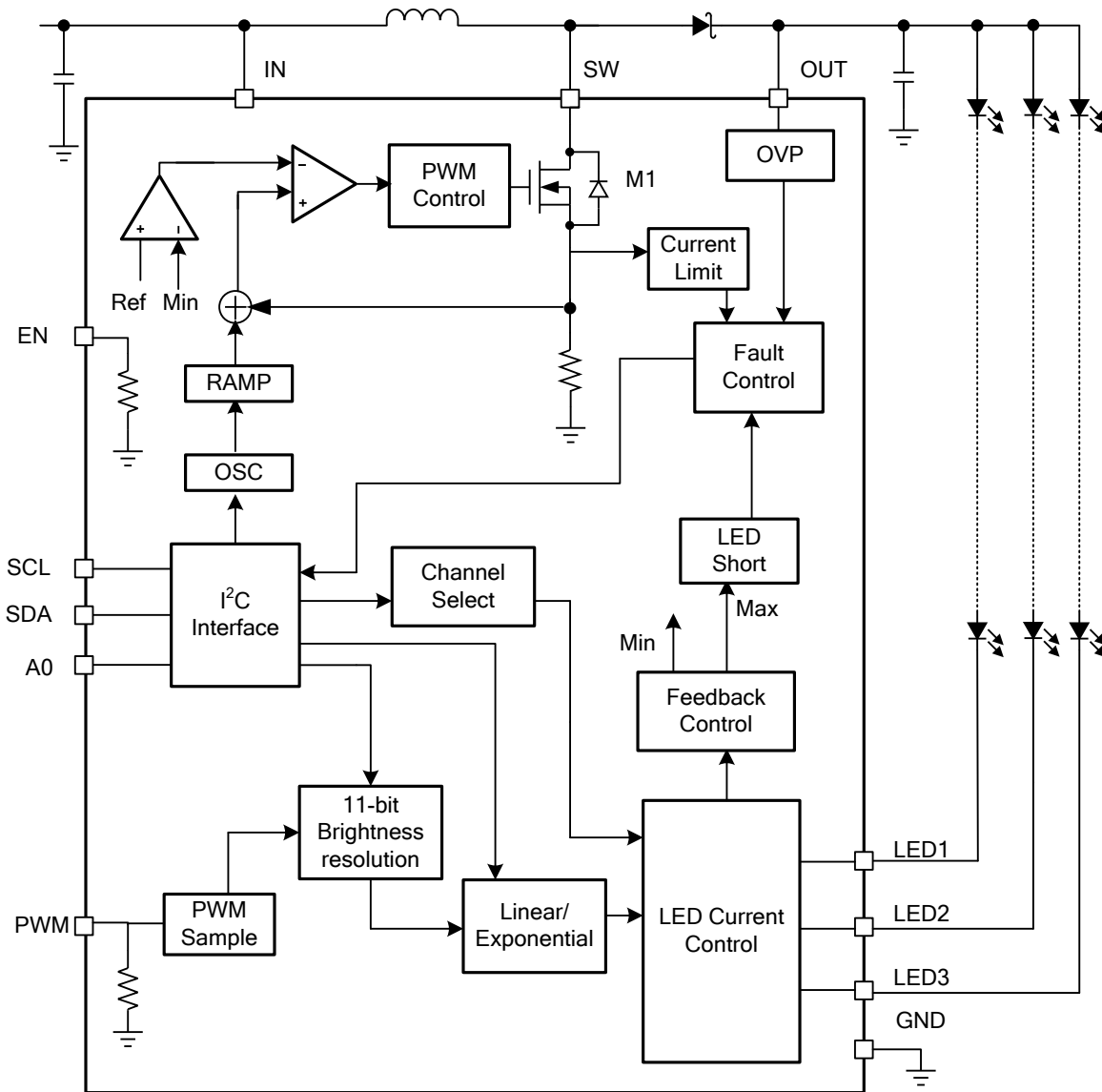

Figure 1: Functional Block Diagram

OPERATION

The MP3313 is a step-up converter with peak-current-mode control architecture that employs three channels of current sink to drive three strings of white LED for an LCD panel. The MP3313 supports 11-bit resolution analog dimming via an internal register or external pulse-width modulation (PWM) input signal.

Boost Converter Switching Frequency

The MP3313 has two selectable switching frequencies (FS) through the I²C interface. When the register bit FS = 1, the switching frequency is set to 1MHz. When the register bit FS = 0, the switching frequency is set to 500kHz. Additionally, the switching frequency can be shifted down 12% by the register FS_SHFT.

Auto-Switching Frequency

To optimize the efficiency in different loads, the MP3313 can select the switching frequency automatically by comparing the auto-switching frequency low threshold (register 0x16) and auto-switching frequency high threshold (register 0x15) to 8MSBs of the brightness code (register 0x19).

The auto-switching frequency function includes three different working frequency points: 1MHz, 500kHz, and 250kHz. At the high threshold, the device switches from 1MHz to 500kHz. At the low threshold, the device switches from 250kHz from 500kHz (see Table 1).

Table 1: Switching Frequency Auto-Function

8MSBs of Brightness Code (register 0x19)	Switching Frequency
<auto switching frequency low threshold (register 0x16)	250kHz
>auto switching frequency low threshold (register 0x16) <auto switching frequency high threshold (register 0x15)	500kHz
>auto switching frequency high threshold (register 0x15)	1MHz

To disable auto-frequency, both the auto-switching frequency high threshold and low threshold must be set to zero. Once the auto-function is disabled, the MP3313 works at a fixed frequency set by the FS bit. The auto-frequency function can be enabled by setting a non-zero code for any one of auto-switching frequency thresholds.

Note that the switching frequency -12% shift is still active when the auto-switching frequency function is enabled.

Minimum Inductor Selection

To optimize the boost converter control loop, the minimum inductance is limited for the MP3313, which is set by the minimum inductor L_MIN bit. When the L_MIN bit is set to 0, the minimum inductor is 4.7μH. When the L_MIN bit is set to 1, the minimum inductor is 10μH.

System Start-Up

If input voltage is higher than the under-voltage lockout (UVLO) threshold and EN is pulled high, the MP3313 enters standby mode. In this mode, only the I²C is active and ready to communicate with the host. Meanwhile, the MP3313 monitors the topology connection and safety limits, including two checks:

- The MP3313 checks whether the OUT pin connection is correct or not. An OUT voltage (V_{OUT}) of less than 1.2V cannot implement device switching and sets the FT_UVP bit to 1.
- The MP3313 checks if the device has triggered LED open/short protection, over-current limit protection, or over-temperature protection (OTP). If all protections pass, the MP3313 then starts boosting the step-up converter with an internal soft start.

To prevent a large inrush current, it is recommended that the power-on sequence be from VIN power-on to PWM power-on to EN power-on. If the external EN pin is always pulled high or to VIN by a resistor, it is requested to write EN to 1 after VIN powers on. When dimming is done by the internal code only, the PWM signal can be ignored.

Boost Converter Operation

The MP3313 uses peak-current mode to control the output voltage. At the start of the internal oscillator cycle, the low-side MOSFET (LS-FET) (M1) is turned on. To prevent sub-harmonic oscillation at duty cycles greater than 50%, a stabilizing ramp is added to the output of the current sense amplifier, and the result is fed into the positive input of the PWM generation comparator. When this voltage equals the

output voltage of the error amplifier, the LS-FET is turned off. Then the inductor current flows through the free-wheeling diode, which forces the inductor current to decrease. The output voltage of the internal error amplifier is an amplified signal of the difference between the reference voltage and the feedback voltage from the LED load cathode. The converter chooses the lowest active LEDx pin voltage automatically to provide a high enough bus voltage to power all of the LED arrays. If the feedback voltage drops below the reference, the output of the error amplifier increases. This results in more current flowing through the LS-FET and delivers more power to the output. This forms a closed control loop that regulates the output voltage.

LED String Selection

There are three LED strings for the MP3313, and each string has an independent EN bit. This allows for 1-string, 2-string, or 3-string application. By default, all three strings are enabled.

Flash Mode

The MP3313 can also work in flash mode by setting the FL_EN bit to 1. The flash time depends on the FL_T bit and ranges from 50 - 800ms. The flash current is set by I_FL bit.

When flash mode is enabled, the inductor peak-current limit value jumps to the flash current limit automatically, which is set by the FL_CL bit (2.5A/3A selectable), and the LED current jumps to the flash current. When the flash is timed out, the LED current and inductor peak current limit returns to backlight mode, and the FL_EN bit is reset to 0. When protection is triggered during the flash, flash mode ends, and the FL_EN bit is reset.

Dimming Control

The MP3313 supports ultra-high resolution analog dimming by converting the PWM input signal or internal register code to the 11-bit brightness code. Two kinds of LED current dimming curve are available: linear and exponential mapping.

The MP3313 converts the external PWM signal into an internal reference via the duty detection

circuit to regulate the current linearly or exponentially.

Calculate the linear analog dimming with Equation (1):

$$I_{LED} = 40.806\mu A + 12.195\mu A \times \text{Code} \quad (1)$$

Where Code ranges from 1 to 2047. Code 0 sets the LED current to 0.

Calculate the exponential analog dimming with Equation (2):

$$I_{LED} = 51.1\mu A \times 1.003040572^{\text{Code}} \quad (2)$$

Where Code ranges from 1 to 2047. Code 0 sets the LED current to 0.

Figure 2 shows the linear and exponential dimming curve for the LED current.

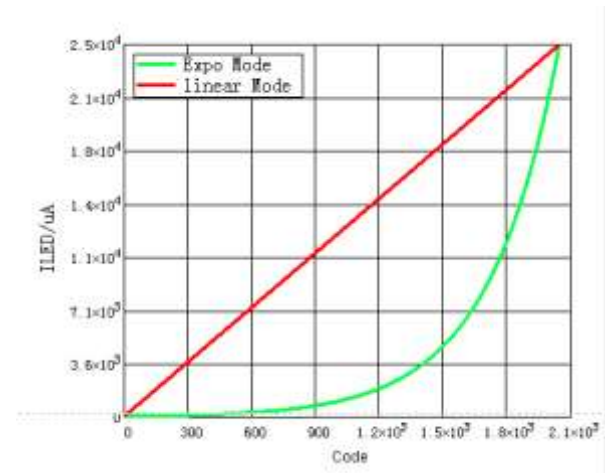

Figure 2: LED Current for Each Channel with Brightness Code

LED Current Ramp Up/Down

The LED current ramps up and down step-by-step from one brightness code to the next when the LED current slope function is enabled by setting the SLPEN bit to 1. The ramp time can be calculated with Equation (3):

$$t_{RAMP} = RAMP \times (\text{Code1} - \text{Code0} - 1) \quad (3)$$

Where RAMP is the slope rate set by the TSLP bit, Code 0 is the original brightness point, and Code 1 is the target brightness point.

PWM Sample Frequency

Three different sample frequencies can be chosen for the input PWM dimming signal for the MP3313.

- PWMSR1:0 bit = 00, sample frequency = 800kHz.
- PWMSR1:0 bit = 01, sample frequency = 4MHz (default).
- PWMSR1:0 bit = 1x, sample frequency = 24MHz.

Choose a PWM sample frequency based on the required dimming resolution, input dimming frequency, and efficiency (the higher the sample frequency, the higher the input consumption current is). A low-level PWM signal that lasts for a certain amount of time can disable the device (see Table 2). The lower the PWM sample frequency is, the longer the PWM shutdown time is.

Table 2: PWM Shutdown Time vs. Sample Frequency

f _{sample} (Hz)	T _{PWM_SD} (ms)
24M	0.6
4M	3
800k	25

PWM Hysteresis

To prevent the input PWM dimming signal jitter from causing LED flicker, the MP3313 offers selectable PWM hysteresis.

- HYS2:0 = 000: no hysteresis
- HYS2:0 = 001: 1 clock
- HYS2:0 = 100: 4 clock (default)
- HYS2:0 = 110: 6 clock

Where 1 clock = 1/fsample. Different sample rates produce different clocks.

The PWM hysteresis is active only when the direction of the LED brightness changes. Once the LED brightness direction changes, the input PWM signal must overcome the hysteresis, and then the brightness changes. Otherwise, if the LED brightness changing direction remains the same, the PWM signal hysteresis function is unused.

Brightness Control Mode

The LED current is controlled either by the input PWM dimming signal or internal brightness register. Five different brightness control modes can be selected and set by the BRTMD2:0 bit.

1. Internal register only: When the brightness control mode bits are set to 000, the LED current is controlled by the internal brightness register only without the PWM signal. The LED current changes only when the eight MSBs are written. Write three LSBs first, then write eight MSBs for 11-bit brightness change.

In linear mapping mode, the LEDs can be calculated with Equation (4) and Equation (5):

$$I_{ILED0} = 40.806\mu A + 12.195\mu A \times \text{Code0} \quad (4)$$

$$I_{ILED1} = 40.806\mu A + 12.195\mu A \times \text{Code1} \quad (5)$$

In exponential mapping mode, the LEDs can be calculated with Equation (6) and Equation (7):

$$I_{ILED0} = 51.1\mu A \times 1.003040572^{\text{Code0}} \quad (6)$$

$$I_{ILED1} = 51.1\mu A \times 1.003040572^{\text{Code1}} \quad (7)$$

The ramp time in either mapping mode can be calculated with Equation (8):

$$t_{RAMP} = RAMP \times (\text{Code1} - \text{Code0} - 1) \quad (8)$$

2. Input PWM duty only: When the brightness control mode bits are set to 001, the LED current is controlled by the input dimming signal only. The internal brightness code is ignored. The MP3313 samples the PWM signal and translates it into an 11-bit code to regulate the current. Choose the corresponding PWM frequency based on the PWM sample rate and resolution request.

In linear mapping mode, the LEDs can be calculated with Equation (9) and Equation (10):

$$I_{ILED0} = 40.806\mu A + 12.195\mu A \times 2047 \times D_{PWM0} \quad (9)$$

$$I_{ILED1} = 40.806\mu A + 12.195\mu A \times 2047 \times D_{PWM1} \quad (10)$$

In exponential mapping mode, the LEDs can be calculated with Equation (11) and Equation (12):

$$I_{ILED0} = 51.1\mu A \times 1.003040572^{2047 \times D_{PWM0}} \quad (11)$$

$$I_{ILED1} = 51.1\mu A \times 1.003040572^{2047 \times D_{PWM1}} \quad (12)$$

The ramp time in either mapping mode can be calculated with Equation (13):

$$t_{\text{RAMP}} = \text{RAMP} \times |2047 \times D_{\text{PWM1}} - 2047 \times D_{\text{PWM0}} - 1| \quad (13)$$

3. Internal register multiplies PWM duty before ramping: LED slope step controlled by internal register and PWM duty. When the brightness control mode bits are set to 010, the LED current is controlled by the input PWM dimming duty multiplied by the internal brightness register. The slope step is also controlled by the PWM dimming duty multiplied by the brightness register.

In linear mode, the LEDs can be calculated with Equation (14) and Equation (15):

$$I_{\text{ILED0}} = 40.806\mu\text{A} + 12.195\mu\text{A} \times \text{Code0} \times D_{\text{PWM0}} \quad (14)$$

$$I_{\text{ILED1}} = 40.806\mu\text{A} + 12.195\mu\text{A} \times \text{Code1} \times D_{\text{PWM1}} \quad (15)$$

In exponential mode, the LEDs can be calculated with Equation (16) and Equation (17):

$$I_{\text{ILED0}} = 51.1\mu\text{A} \times 1.003040572^{\text{Code0} \times D_{\text{PWM0}}} \quad (16)$$

$$I_{\text{ILED1}} = 51.1\mu\text{A} \times 1.003040572^{\text{Code1} \times D_{\text{PWM1}}} \quad (17)$$

The ramp time in either mapping mode can be calculated with Equation (18):

$$t_{\text{RAMP}} = \text{RAMP} \times | \text{Code1} \times D_{\text{PWM1}} - \text{Code0} \times D_{\text{PWM0}} - 1 | \quad (18)$$

4. Ramp before internal register multiplies input PWM dimming duty, LED slope step controlled by internal register only: When the brightness control mode bits are set to 011, the LED current is controlled by the input PWM dimming duty multiplied by the internal brightness register. The slope step is controlled by the internal brightness register only.

In this mode, the LED current jumps immediately when the external PWM dimming duty changes. Then the LED current changes step-by-step to the new brightness register.

In linear mapping mode, the original current can be calculated with Equation (19):

$$I_{\text{ILED0}} = 40.806\mu\text{A} + 12.195\mu\text{A} \times \text{Code0} \times D_{\text{PWM0}} \quad (19)$$

The LED current jumps immediately when the duty changes, as shown in Equation (20):

$$I_{\text{ILED0+}} = 40.806\mu\text{A} + 12.195\mu\text{A} \times \text{Code0} \times D_{\text{PWM1}} \quad (20)$$

The LED current follows the code changes shown in Equation (21):

$$I_{\text{ILED1}} = 40.806\mu\text{A} + 12.195\mu\text{A} \times \text{Code1} \times D_{\text{PWM1}} \quad (21)$$

In exponential mapping mode, the original current can be calculated with Equation (22):

$$I_{\text{ILED0-}} = 51.1\mu\text{A} \times 1.003040572^{\text{Code0} \times D_{\text{PWM0}}} \quad (22)$$

The LED current jumps immediately when the duty changes, as shown in Equation (23):

$$I_{\text{ILED0+}} = 51.1\mu\text{A} \times 1.003040572^{\text{Code0} \times D_{\text{PWM1}}} \quad (23)$$

Then, the LED current follows the code changes shown in Equation (24):

$$I_{\text{ILED1}} = 51.1\mu\text{A} \times 1.003040572^{\text{Code1} \times D_{\text{PWM1}}} \quad (24)$$

The ramp time in either mode can be calculated with Equation (25):

$$t_{\text{RAMP}} = \text{RAMP} \times | \text{Code1} - \text{Code0} - 1 | \quad (25)$$

For example, the PWM duty changes from 50% to 100%, and the brightness register changes from 1024 to 2047, the slope is 1ms/step in linear analog dimming.

The original LED current can be calculated with Equation (26):

$$I_{\text{ILED0-}} = 40.806\mu\text{A} + 12.195\mu\text{A} \times (1024 \times 0.5) = 6.28\text{mA} \quad (26)$$

Then the LED current jumps immediately, as shown in Equation (27):

$$I_{\text{ILED0+}} = 40.806\mu\text{A} + 12.195\mu\text{A} \times (1024 \times 1) = 12.52\text{mA} \quad (27)$$

The LED current rise up step-by-step, shown in Equation (28):

$$I_{\text{ILED1}} = 40.806\mu\text{A} + 12.195\mu\text{A} \times (2047 \times 1) = 25\text{mA} \quad (28)$$

The ramp-up time can be calculated with Equation (29):

$$t_{\text{RAMP}} = 1\text{ms/step} \times |2047 - 1024 - 1| = 1022\text{ms} \quad (29)$$

5. LED current multiplied by the input PWM duty, LED slope step controlled by the internal register only: When the brightness control mode bits are set to 100, the LED current is dimmed by the input PWM dimming duty, and slope step is controlled by the internal brightness register only.

In linear mode, the LEDs can be calculated with Equation (30) and Equation (31):

$$I_{LED0} = (40.806\mu A + 12.195\mu A \times \text{Code0}) \times D_{PWM0} \quad (30)$$

$$I_{LED1} = (40.806\mu A + 12.195\mu A \times \text{Code1}) \times D_{PWM1} \quad (31)$$

In exponential mode, the LEDs can be calculated with Equation (32) and Equation (33):

$$I_{LED0} = 51.1\mu A \times 1.003040572^{\text{Code0}} \times D_{PWM0} \quad (32)$$

$$I_{LED1} = 51.1\mu A \times 1.003040572^{\text{Code1}} \times D_{PWM1} \quad (33)$$

The ramp time in either mode can be calculated with Equation (34):

$$t_{RAMP} = RAMP \times |\text{Code1} - \text{Code0} - 1| \quad (34)$$

Cycle-by-Cycle Current Limit

To prevent the external components from exceeding the current stress rating, the MP3313 uses a cycle-by-cycle current limit protection. The limit value can be selected by the register bit CL1:0. When the internal LS-FET current exceeds the current limit threshold, the MOSFET turns off until the next clock cycle begins.

Over-Current Protection (OCP)

The FT_OCP flag is set when over-current protection (OCP) occurs. To prevent the transient over-current from setting the FT_OCP bit, the MP3313 designs an OCP counter. If the inductor current always reaches the threshold in a 128μs period, the counter increases by 1. Every eight 128μs periods, if the OCP counter is higher than 2, the FT_OCP bit is set to 1.

If OCP_SD = 0, the IC latches off when OCP is triggered. If OCP_SD = 1, the IC is recoverable when OCP is triggered.

Over-Voltage Protection and Open-String Protection

When V_{OUT} is higher than the over-voltage protection (OVP) threshold, OVP is triggered, the IC stops switching, and the FT_OVP bit is set. When the output voltage drops low, switching recovers.

The OVP threshold is set by the internal register OVP1:0. Four different thresholds can be selected.

- OVP1:0 = 00: 17V
- OVP1:0 = 01: 23V
- OVP1:0 = 10: 30V
- OVP1:0 = 11: 38V (default)

If the LED string is open, the feedback voltage is lower than the reference voltage, and V_{OUT} rises up and continues charging the output capacitor until OUT reaches the protection point (V_{OVP}), and OVP is triggered. The IC also monitors the LEDx voltage. When the LEDx voltage is lower than 40mV, open LED protection is triggered. Three different actions can be set by OVP_MD1:0 through the I²C after a fault is triggered.

- OVP_MD1:0 = 00: FT_OVP is set, and FT_OLP is set.
- OVP_MD1:0 = 01: FT_OVP is set, FT_OLP is set, and the string is marked off with LEDx < 40mV.
- OVP_MD1:0 = 10: FT_OVP is set, and the IC latches off when the OVP fault is detected.

Short LED Protection

The MP3313 monitors the LEDx voltage to determine if a short string has occurred. If a short occurs, the respective LEDx pin is pulled up and can tolerate high voltage stress. If the LEDx voltage is higher than the short-protection threshold and lasts for 2ms, a short string fault is detected. The threshold is set by S_TH1:0.

Short LED protection is programmed by SLP_MD1:0.

- SLP_MD1:0 = 00: The short LED fault detection is disabled.
- SLP_MD1:0 = 01: The short LED fault detection is enabled, and the FT_SLP is set when the fault is detected.
- SLP_MD1:0 = 10: The short LED fault detection is enabled, the FT_SLP is set, and the string is marked off with the LEDx voltage that is higher than the threshold.
- SLP_MD1:0 = 11: FT_SLP is set, and the IC latch off when the fault is detected.

Thermal Shutdown Protection

To prevent the IC from operating at an exceedingly high temperature, thermal shutdown is implemented in the MP3313 by detecting the silicon die temperature. When the die temperature exceeds the upper threshold (T_{ST}), the IC shuts down and resumes normal operation when the die temperature drops below the lower threshold. Typically, the hysteresis value is 25°C. If OTP_SD = 0, the IC latches off when OTP is triggered.

I²C Chip Address

The 7-bit MSB device address is 0x36 - 0x37 selected by A0. If A0 is floating, it must be pulled up or down externally to set the address.

After the start condition, the I²C-compatible master sends a 7-bit address followed by an eighth read (1) or write (0) bit. The following bit indicates the register address to or from which the data is written or read (see Figure 3).

0	1	1	0	1	1	A0	r/w
---	---	---	---	---	---	----	-----

Figure 3: The I²C Compatible Device Address

To avoid a glitch in the operation, the following bit changes only when the IC EN bit (0x10, bit[0]) or the three LED channel enable bits (0x10, bit[3:1]) are set to 0.

The following bit should contain these bits:

1. Mapping mode bit (MAPMOD, 0x11, bit[7])
2. Brightness mode bits (BRTMD2:0, 0x11, bit[6:4])
3. Slope enable bit (SLPEN, 0x11, bit[3])
4. Slope time bit (TSLP2:0, 0x11, bit[2:0])
5. PWM sample rate bit (PWMSR1:0, 0x12, bit[7:6])
6. PWM polarity bit (PWM_P, 0x12, bit[5])
7. PWM hysteresis bit (HYS2:0, 0x12, bit [4:2])
8. PWM filter bit (FILTER1:0, 0x12, bit[1:0])
9. Auto frequency high threshold bit (FS_AUTOH7:0, 0x15, bit[7:0])
10. Auto frequency low threshold bit (FS_AUTOL7:0, 0x16, bit[7:0])

Table 3: Register Mapping

Add	D7	D6	D5	D4	D3	D2	D1	D0
00H	DEV_ID3	DEV_ID2	DEV_ID1	DEV_ID0	REV_ID3	REV_ID2	REV_ID1	REV_ID0
01H	RESERVED							SRST
10H	RESERVED				CH3EN	CH2EN	CH1EN	EN
11H	MAPMD	BRTMD2:0			SLPEN	TSLP2:0		
12H	PWMSR1:0		PWM_P	HYS2:0			FILTER1:0	
13H	NA	FS_SHFT	FS	L_MIN	OVP1:0		CL1:0	
14H	FL_CL	IFL6:0						
15H	FS_AUTOH7:0							
16H	FS_AUTOL7:0							
17H	FL_T3:0				RESERVED			FL_EN
18H	RESERVED					BRT2:0		
19H	BRT10:3							
1EH	S_TH1:0		SLP_MD1:0		OVP_MD1:0		OTP_SD	OCP_SD
1FH	RESERVED		FT_UVP	FT_OLP	FT_SLP	FT_OTP	FT_OCP	FT_OVP

Table 4: Chip ID Register

Addr: 0x00				
Bit	Bit Name	Access	Default	Description
7:4	DEV_ID	r	000	Device ID.
3:0	REV_ID	r	0001	Revision ID.

Table 5: Software Reset Register

Addr: 0x01				
Bit	Bit Name	Access	Default	Description
7:1	N/A	r	N/A	Reserved.
0	SRST	r/w	0	Software reset bit. 0: normal operation 1: device resets, all registers are reset to default (this bit automatically resets back to 0)

Table 6: Enable Register

Addr: 0x10				
Bit	Bit Name	Access	Default	Description
7:4	N/A	r	N/A	Reserved.
3	CH3EN	r/w	1	LED3 enable bit. 1: LED3 enabled 0: LED3 disabled
2	CH2EN	r/w	1	LED2 enable bit. 1: LED2 enabled 0: LED2 disabled
1	CH1EN	r/w	1	LED1 enable bit. 1: LED1 enabled 0: LED1 disabled
0	EN	r/w	1	IC enable bit 1: IC enabled 0: IC disabled

Table 7: Brightness Control Register

Addr: 0x11				
Bit	Bit Name	Access	Default	Description
7	MAPMD	r/w	0	LED current mapping mode bit. 0: linear mapping 1: exponential mapping
6:4	BRTMD2:0	r/w	011	Brightness mode control bits. 000: brightness register only 001: PWM duty only 010: brightness register multiplies PWM duty before ramp 011: ramp before brightness register multiplies PWM duty 100: LED current multiplies PWM duty
3	SLPEN	r/w	0	LED current slope enable bit. 0: LED current slope disabled 1: LED current slope enabled
2:0	TSLP2:0	r/w	000	LED current slope time for each step. 000: 0.125ms/step 001: 0.25ms/step 010: 0.5ms/step 011: 1ms/step 100: 2ms/step 101: 4ms/step 110: 8ms/step 111: 16ms/step

Table 8: PWM Control Register

Addr: 0x12				
Bit	Bit Name	Access	Default	Description
7:6	PWMSR	r/w	01	PWM sample frequency set bits. 00: 800kHz 01: 4MHz 1x: 24MHz
5	PWM_P	r/w	1	PWM input polarity set bit. 0: active low 1: active high
4:2	HYS2:0	r/w	100	PWM hysteresis set bits. 000: no hysteresis 001: 1 clock 010: 2 clock 011: 3 clock 100: 4 clock 101: 5 clock 110: 6 clock 111: reserved
1:0	FILTER1:0	r/w	11	PWM input filter bits. 00: no filter 01: 80ns 10: 160ns 11: 240ns

Table 9: Boost Control Register

Addr: 0x13				
Bit	Bit Name	Access	Default	Description
7	N/A	r	N/A	Reserved.
6	FS_SHFT	r/w	1	Switching frequency shift bit. 0: -12% shift 1: no shift
5	FS	r/w	1	Boost switching frequency set bit. 0: 500kHz 1: 1MHz
4	L_MIN	r/w	0	Minimum inductor select bit. 0: 4.7μH 1: 10μH
3:2	OVP1:0	r/w	11	Over-voltage protection set bits. 00: 17V 01: 23V 10: 30V 11: 38V
1:0	CL1:0	r/w	11	Current limit set bits. 00: 0.75A 01: 1A 10: 1.25A 11: 1.5A

Table 10: Flash Current Set Register

Addr: 0x14				
Bit	Bit Name	Access	Default	Description
7	FL_CL	r/w	0	Current limit in flash mode. 0: 2.5A 1: 3A
6:0	IFL6:0	r/w	0101000	Flash current set register. 1mA/step. 0x0A: 10mA 0x0B: 11mA 0x28: 40mA (default) ... 0x64: 100mA 0x64~7F: reserved

Table 11: Auto-Switching Frequency High Threshold

Addr: 0x15				
Bit	Bit Name	Access	Default	Description
7:0	FS_AUTOH	r/w	00000000	Auto-switching frequency high threshold (500kHz to 1MHz). Compared with the 8 MSBs of the brightness code. The function is disabled when both FS_AUTOH and FS_AUTOL are set to 0.

Table 12: Auto-Switching Frequency Low Threshold

Addr: 0x16				
Bit	Bit Name	Access	Default	Description
7:0	FS_AUTOL	r/w	00000000	Auto-switching frequency low threshold (250kHz to 500kHz). Compared with the 8 MSBs of the brightness code. The function is disabled when both FS_AUTOH and FS_AUTOL are set to 0.

Table 13: Flash Mode Control Register

Addr: 0x17				
Bit	Bit Name	Access	Default	Description
7:4	FL_T	r/w	0101 (300ms)	Flash time set register. 50ms/step. 0000: 50ms 0001: 100ms 1111: 800ms
3:1	N/A	r	000	Reserved.
0	FL_EN	r/w	0	Backlight flash mode enable bit. 0: disable 1: enable Automatically resets to 0 when flash timeout or protection is triggered.

Table 14: Brightness Register LSB

Addr: 0x18				
Bit	Bit Name	Access	Default	Description
7:3	N/A	r	N/A	Reserved.
2:0	BRT2:0	r/w	111	3-bit LSB of the brightness register.

Table 15: Brightness Register MSB

Addr: 0x19				
Bit	Bit Name	Access	Default	Description
7:0	BRT10:3	r/w	11111111	8-bit MSB of the brightness register.

Table 16: Fault Control Register

Addr: 0x1E				
Bit	Bit Name	Access	Default	Description
7:6	S_TH	r/w	01	LED short-protection threshold setting. If the LEDx voltage is higher than the threshold, short protection is triggered. 00: 2V 01: 3V 10: 5V 11: reserved
5:4	SLP_MD	r/w	00	LED short protection mode selection. 00: LED short protection is disabled 01: FT_SLP is set when a fault is detected 10: FT_SLP is set and the fault string is marked off 11: FT_SLP is set and the IC latches off
3:2	OVP_MD	r/w	00	Over-voltage protection mode selection. 00: FT_OVP is set when a fault is detected 01: FT_OVP is set and the open string is marked off 10: FT_OVP is set and the IC latches off 11: reserved
1	OTP_SD	r/w	1	Thermal shutdown latch off disable bit. 0: IC latches off when OTP is triggered 1: no latch off
0	OCP_SD	r/w	1	Over-current protection latch off disable bit. 0: IC latches off when OCP is triggered 1: no latch off

Table 17: Fault Flag Register

Addr: 0x1F				
Bit	Bit Name	Access	Default	Description
7:6	N/A	r	N/A	Reserved.
5	FT_UVP	r	0	Output under-voltage fault flag. 0: no fault 1: fault, clear after readback
4	FT_OLP	r	0	LED open fault flag. 0: no fault 1: fault, clear after readback
3	FT_SLP	r	0	LED short fault flag. 0: no fault 1: fault, clear after readback
2	FT_OTP	r	0	Thermal shutdown fault flag. 0: no fault 1: fault, clear after readback
1	FT_OCP	r	0	Over-current protection fault flag. 0: no fault 1: fault, clear after readback
0	FT_OVP	r	0	Output voltage OVP fault flag. 0: no fault 1: fault, clear after readback

APPLICATION INFORMATION

Selecting the Input Capacitor

The input capacitor reduces the surge current drawn from the input supply and the switching noise from the device. The input capacitor impedance at the switching frequency should be much less than the input source impedance to prevent the high-frequency switching current from passing through to the input. Ceramic capacitors with X5R or X7R dielectrics are recommended for their low ESR and small temperature coefficients. For most applications, a 1 ~ 4.7µF ceramic capacitor is sufficient.

Selecting the Inductor

The converter requires an inductor to supply a high output voltage while being driven by the input voltage. A larger value inductor results in less ripple current, lower peak inductor current, and less stress on the internal N-channel MOSFET. However, the larger inductor also has a larger physical size, higher series resistance, and lower saturation current.

Choose an inductor that will not saturate under the worst-case load conditions. Select the minimum inductor value to ensure that the boost converter works in continuous conduction mode (CCM) with high efficiency and good EMI performance.

Calculate the required inductance value using Equation (35) and Equation (36):

$$L \geq \frac{\eta \times V_{OUT} \times D \times (1-D)^2}{2 \times f_{SW} \times I_{LOAD}} \quad (35)$$

$$D = 1 - \frac{V_{IN}}{V_{OUT}} \quad (36)$$

Where V_{IN} is the input voltage, V_{OUT} is the output voltage, f_{SW} is the switching frequency, I_{LOAD} is the LED load current, and η is the efficiency.

The switching current is used for peak-current-mode control. To prevent hitting the current limit, the worst-case inductor peak current should be less than 80% of the current limit (I_{LIM}). For most applications, a 4.7 ~ 10µH inductor is sufficient.

Selecting the Output Capacitor

The output capacitor keeps the output voltage ripple small and ensures feedback loop stability. The output capacitor impedance must be low at the switching frequency. Ceramic capacitors with X7R dielectrics are recommended for their low ESR characteristics. Note that the ceramic capacitance is dependent on the voltage rating. With a DC bias voltage, the capacitance can lose as much as 50% of its value at its rated voltage rating. Leave a large enough voltage rating margin when selecting the component. Too low a capacitance value causes loop instability. For most applications, a 10µF ceramic capacitor is sufficient.

Selecting the External Schottky Diode

To optimize the efficiency, a high-speed and low reverse-recovery current Schottky diode are recommended. Make sure the diode's average and peak current ratings exceed the output average LED current and the peak inductor current. In addition, the diode's break-down voltage rating should be large than the maximum voltage across the diode. Usually, unexpected high-frequency voltage spikes can be seen across the diode when the diode turns off. Therefore, leaving some voltage rating margin is always needed to guarantee normal long-term operation when selecting a diode.

PCB Layout Guidelines

Efficient PCB layout is critical for stable operation. Proper layout of the high-frequency switching path is critical to prevent noise and electromagnetic interference problems. For best results, refer to the guidelines below.

1. Minimize the loop of MP3313's internal LS-FET, Schottky diode, and output capacitor, since it is flowing with high-frequency ripple current.
2. Place the input and output capacitors as close to the IC as possible.

TYPICAL APPLICATION CIRCUIT

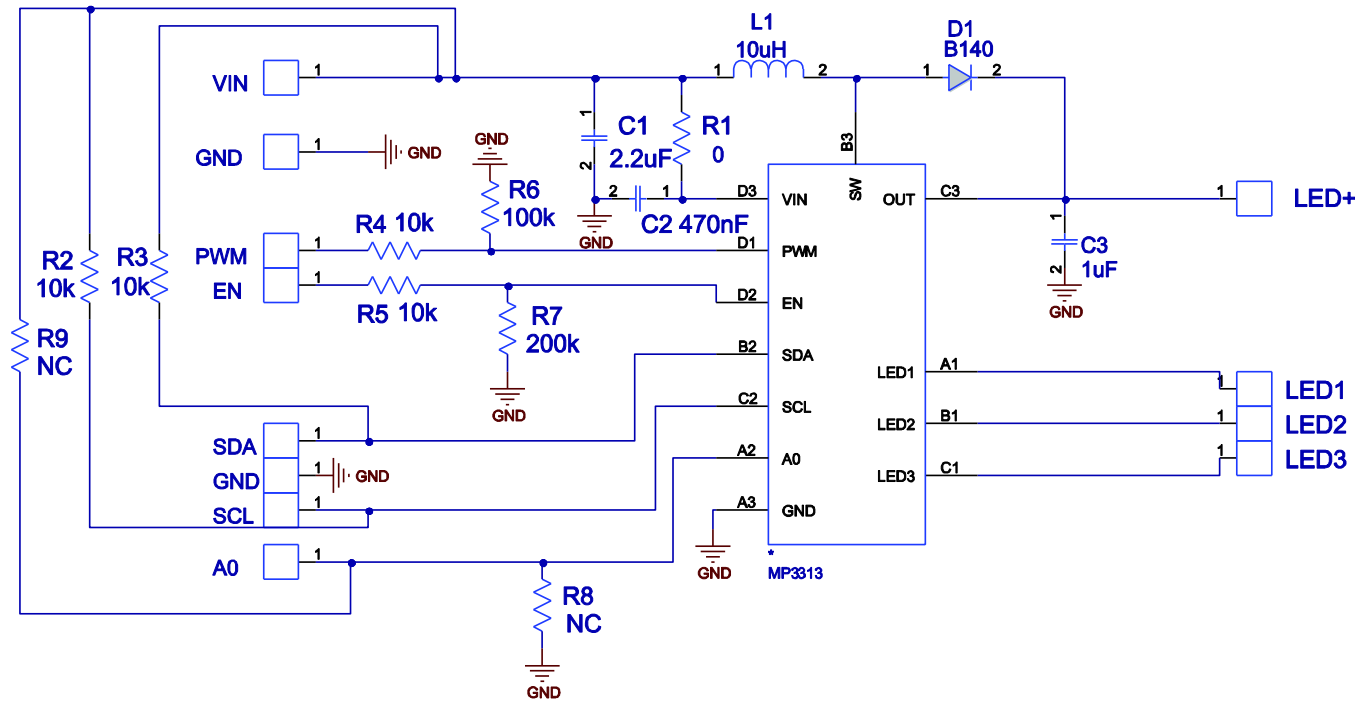
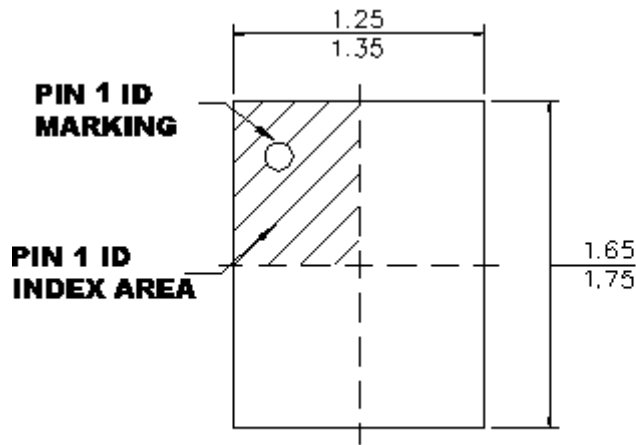

Figure 4: Typical Application for Single-String 3*7LEDs, 20mA/String

PACKAGE INFORMATION

CSP12 (1.3mmx1.7mm)



TOP VIEW

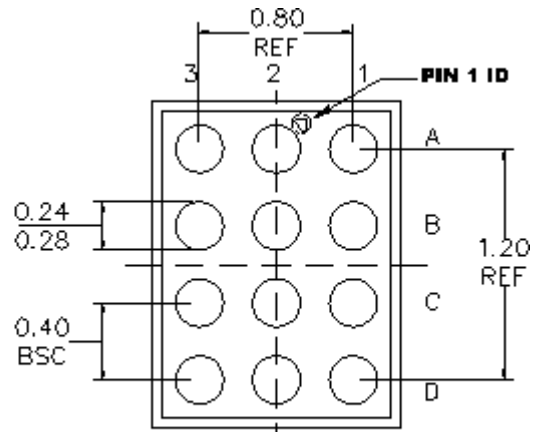

BOTTOM VIEW

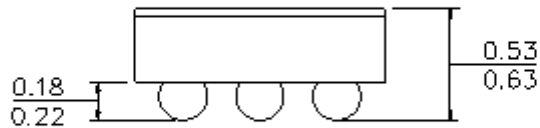

SIDE VIEW

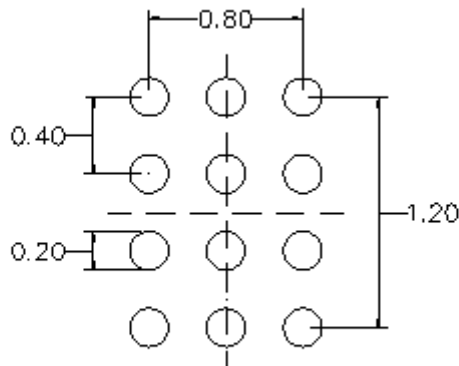

RECOMMENDED LAND PATTERN

NOTE:

- 1) ALL DIMENSIONS ARE IN MILLIMETERS.
- 2) BALL COPLANARITY SHALL BE 0.05 MILLIMETER MAX.
- 3) JEDEC REFERENCE IS MO-211.
- 4) DRAWING IS NOT TO SCALE.

NOTICE: The information in this document is subject to change without notice. Users should warrant and guarantee that third party Intellectual Property rights are not infringed upon when integrating MPS products into any application. MPS will not assume any legal responsibility for any said applications.

Компания «Океан Электроники» предлагает заключение долгосрочных отношений при поставках импортных электронных компонентов на взаимовыгодных условиях!

Наши преимущества:

- Поставка оригинальных импортных электронных компонентов напрямую с производств Америки, Европы и Азии, а так же с крупнейших складов мира;
- Широкая линейка поставок активных и пассивных импортных электронных компонентов (более 30 млн. наименований);
- Поставка сложных, дефицитных, либо снятых с производства позиций;
- Оперативные сроки поставки под заказ (от 5 рабочих дней);
- Экспресс доставка в любую точку России;
- Помощь Конструкторского Отдела и консультации квалифицированных инженеров;
- Техническая поддержка проекта, помощь в подборе аналогов, поставка прототипов;
- Поставка электронных компонентов под контролем ВП;
- Система менеджмента качества сертифицирована по Международному стандарту ISO 9001;
- При необходимости вся продукция военного и аэрокосмического назначения проходит испытания и сертификацию в лаборатории (по согласованию с заказчиком);
- Поставка специализированных компонентов военного и аэрокосмического уровня качества (Xilinx, Altera, Analog Devices, Intersil, Interpoint, Microsemi, Actel, Aeroflex, Peregrine, VPT, Syfer, Eurofarad, Texas Instruments, MS Kennedy, Miteq, Cobham, E2V, MA-COM, Hittite, Mini-Circuits, General Dynamics и др.);

Компания «Океан Электроники» является официальным дистрибьютором и эксклюзивным представителем в России одного из крупнейших производителей разъемов военного и аэрокосмического назначения «JONHON», а так же официальным дистрибьютором и эксклюзивным представителем в России производителя высокотехнологичных и надежных решений для передачи СВЧ сигналов «FORSTAR».



JONHON

«JONHON» (основан в 1970 г.)

Разъемы специального, военного и аэрокосмического назначения:

(Применяются в военной, авиационной, аэрокосмической, морской, железнодорожной, горно- и нефтедобывающей отраслях промышленности)

«FORSTAR» (основан в 1998 г.)

ВЧ соединители, коаксиальные кабели,
кабельные сборки и микроволновые компоненты:

(Применяются в телекоммуникациях гражданского и специального назначения, в средствах связи, РЛС, а так же военной, авиационной и аэрокосмической отраслях промышленности).



Телефон: 8 (812) 309-75-97 (многоканальный)

Факс: 8 (812) 320-03-32

Электронная почта: ocean@oceanchips.ru

Web: <http://oceanchips.ru/>

Адрес: 198099, г. Санкт-Петербург, ул. Калинина, д. 2, корп. 4, лит. А