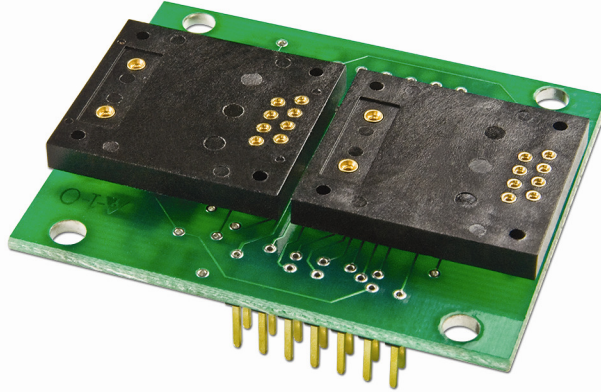

OLED Logic Boards Users Manual

Revision B

**NKK SWITCHES**7850 E. Gelding Drive
Scottsdale, AZ 85260

Toll Free 1-877-2BUYNKK (877-228-9655)

Phone 480-991-0942

Fax 480-998-1435

e-mail <engineering@nkkswitches.com>

All Rights Reserved Worldwide

NKK Switches makes no warranty for the use of these products and assumes no responsibility for any errors, which may appear in this document, nor does it make a commitment to update the information contained herein. Smart Switch is trademark of NKK Switches.

TABLE OF CONTENTS

Table of Contents	2
1. Preface.....	3
2. General Logic Board Features	3
3. Part Number Configuration	3
4. Standard Part Numbers	4
5. Connectors	5
6. Board Dimensions.....	7
7. Schematics.....	9
8. Key Terms & Definitions.....	11

1. Preface

The OLED 64x48 logic boards are used for mounting OLED 64x48 SmartSwitches or 52x36 SmartDisplays into panels and system assemblies. The 2 switch versions are also used in the SmartSwitch Dev Kits as demonstration platforms for the SmartSwitch and SmartDisplays. This user manual will go through general features. The NKK Switches' SmartSwitch web site is <http://www.nkksmartswitch.com/>.

2. General Logic Control Features

The OLED 64x48 logic boards are PCB's that have mount positions for one or more OLED 64x48 SmartSwitches or 52x36 SmartDisplays. The switches/displays can be mounted directly on the logic board or on a socket mounted on the board. One or two switch boards are the most common but logic boards with other configurations are available as well as custom designs. They have some "glue logic" for converting the select lines and switch scanning to serial, and therefore many logic boards can be daisy-chained via 14-pin ribbon cables. The switch numbering is according to their order in the daisy-chain, where the switch number one is on the logic board connected directly to the controller.

There are two types of OLED 64x48 logic boards; RGB pushbutton and RGB display.

3. Part Number Configuration

The logic board part numbers are divided up by their attributes.

1 2 3 4
IS - L02L1 - C - ISC15ANP4

1. IS Prefix.
2. The Logic Board base part number. The first number is the quantity of switch positions on the board. The second number is the version.
3. No code = No socket for IS switches.
C = Sockets are soldered to the PCB for IS switches.
4. No code = No IS switches.
IS15... = The logic board is populated by the IS Switches.

Logic boards can be customized based on customer requirements.

4. Standard Part Numbers

One or two switch boards are the most common but logic boards with other configurations are available as well as custom designs. NKK Switches will work with customers to design and build custom logic boards to fit customer requirements.

Part number examples used in IS Dev Kits:

SmartSwitch Configuration	Part Number	Description
Two OLED 64x48 RGB Pushbutton	IS-L02L1-C	With socket
	IS-L02L1-ISC15ANP4	With switches mounted directly
	IS-L02L1-C-ISC15ANP4	With switches mounted on sockets
Two OLED 52x36 RGB Display	IS-L02F1-C	With socket
	IS-L02F1-ISC01P	With switches mounted directly
	IS-L02F1-C-ISC01P	With switches mounted on sockets

5. Connectors

The SmartSwitch Controller connects to the J1 of the first logic board via 14 pin ribbon cables. The J2 of the first logic board connect to J1 of the second logic board and so on.

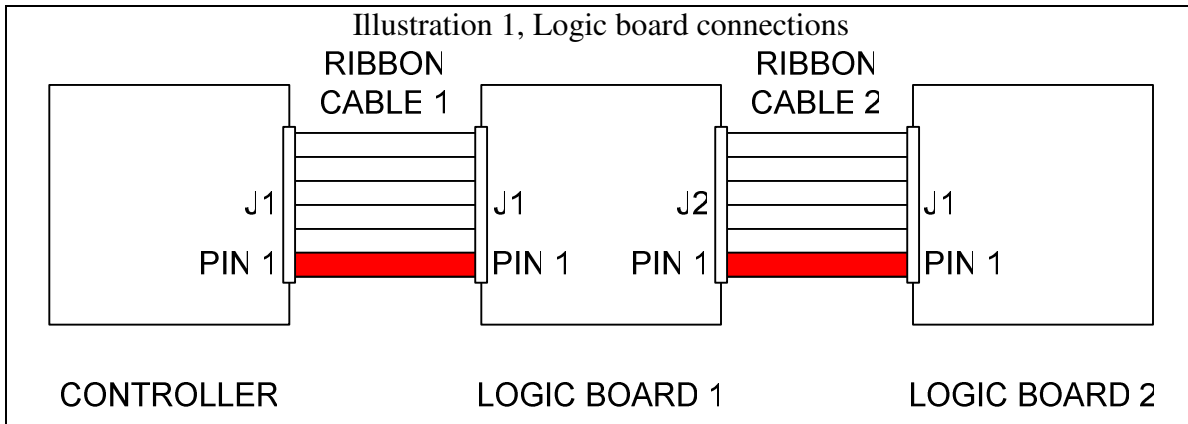

Note: Attaching the ribbon cable without the red line on pin 1 on each of the headers may cause damage to the controller or the logic board.

The logic boards have two connectors:

J1 Input port: 7x2 male header .1"x.1" spacing.

This connector connects to the controller port or J2 of the previous logic board in the daisy chain.

Pin	Function	
1	RES	Reset
2	GND	Ground
3	DIN	Din of all SmartSwitches
4	GND	Ground
5	SCK	SCK of all SmartSwitches
6	oe	Driver Output Enable. Can be connected to gnd.
7	VCC	3.3V Supply
8	V16	16V Supply
9	DC	Data Command
10	Pen	NC
11	CLKss	Clock for all shift registers
12	DATAss	Din of the first shift register
13	LPss	Latch all shift register outputs to the all drivers
14	SWRD	Switch Read bus for all SmartSwitches

J2 Output port: 7x2 male header .1"x.1" spacing.

This connector connects to J1 of the next logic board in the daisy chain.

Pin	Function	
1	RES	Connected to J1
2	GND	Connected to J1
3	DIN	Connected to J1
4	GND	Connected to J1
5	SCK	Connected to J1
6	oe	Connected to J1
7	VCC	Connected to J1
8	V16	Connected to J1
9	DC	Connected to J1
10	Pen	Connected to J1
11	CLKss	Connected to J1
12	DATAss	Connected to Dout of the last shift register
13	LPss	Connected to J1
14	SWRD	Connected to J1

6. Board Dimensions

Logic Board Dimensions for IS-L02L1:

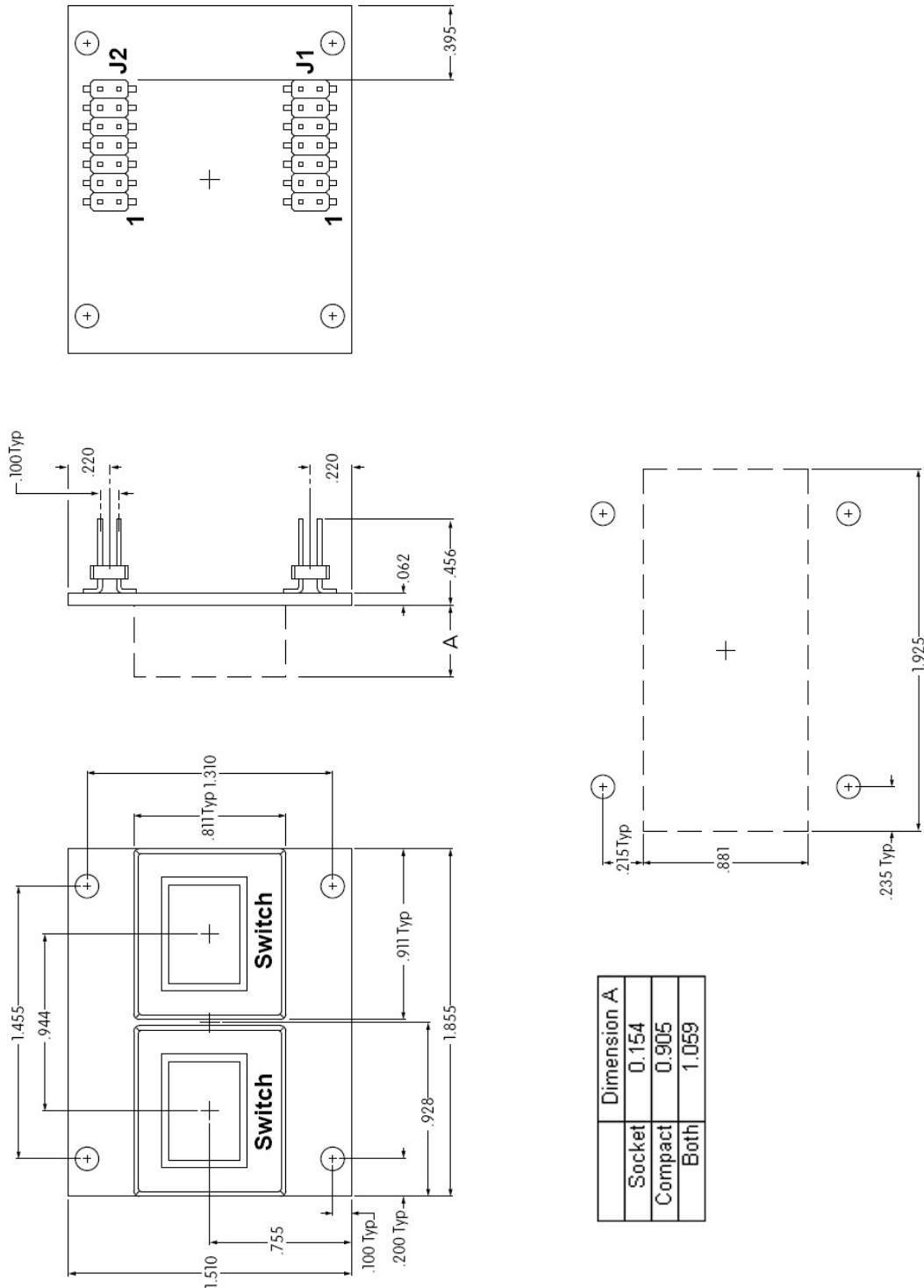

Dimension A	Socket	Compact	Both
	0.154	0.905	1.059

Logic Board Dimensions for IS-L02P1:

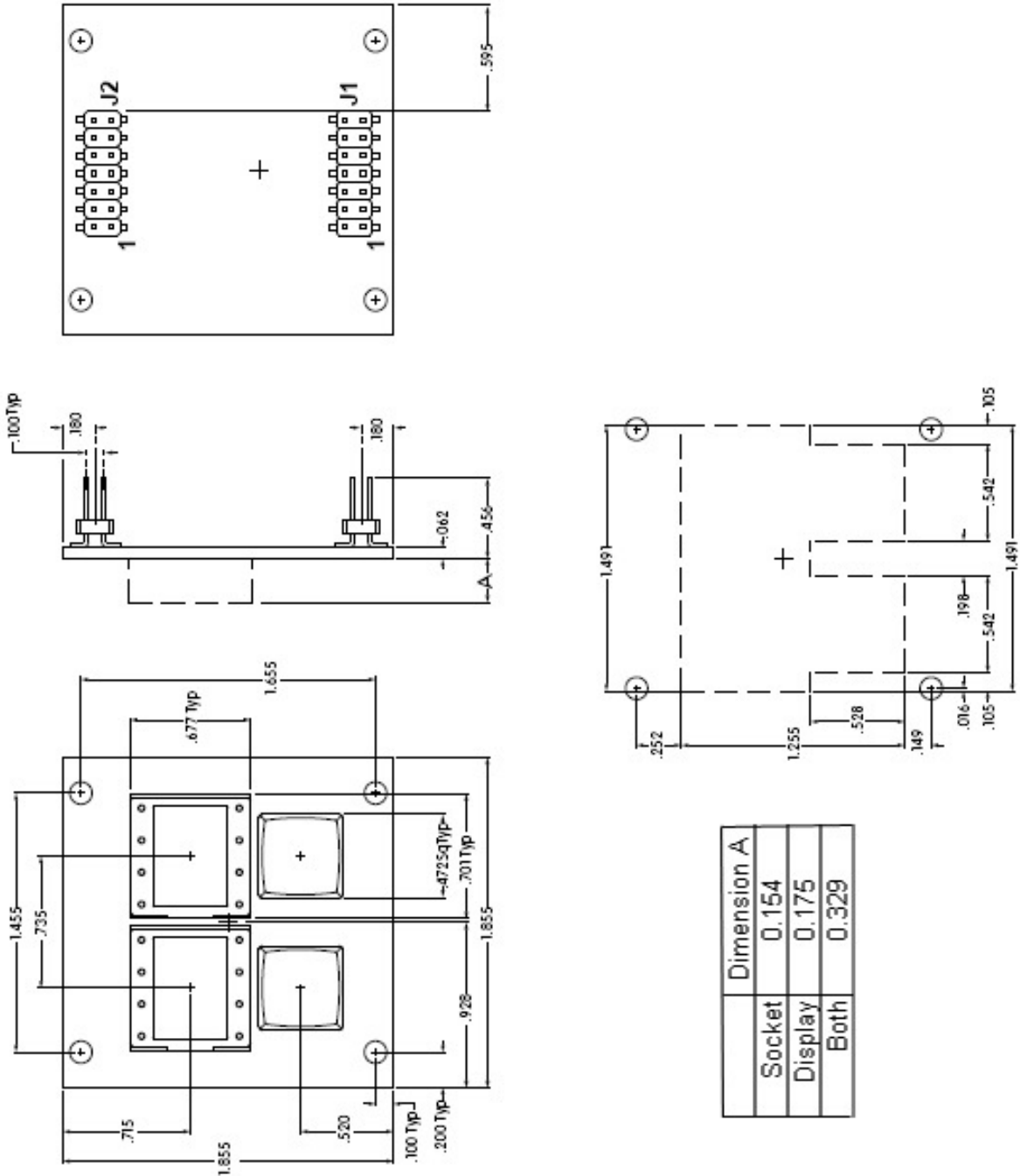

7. Schematics

Schematic for IS-L02L1:

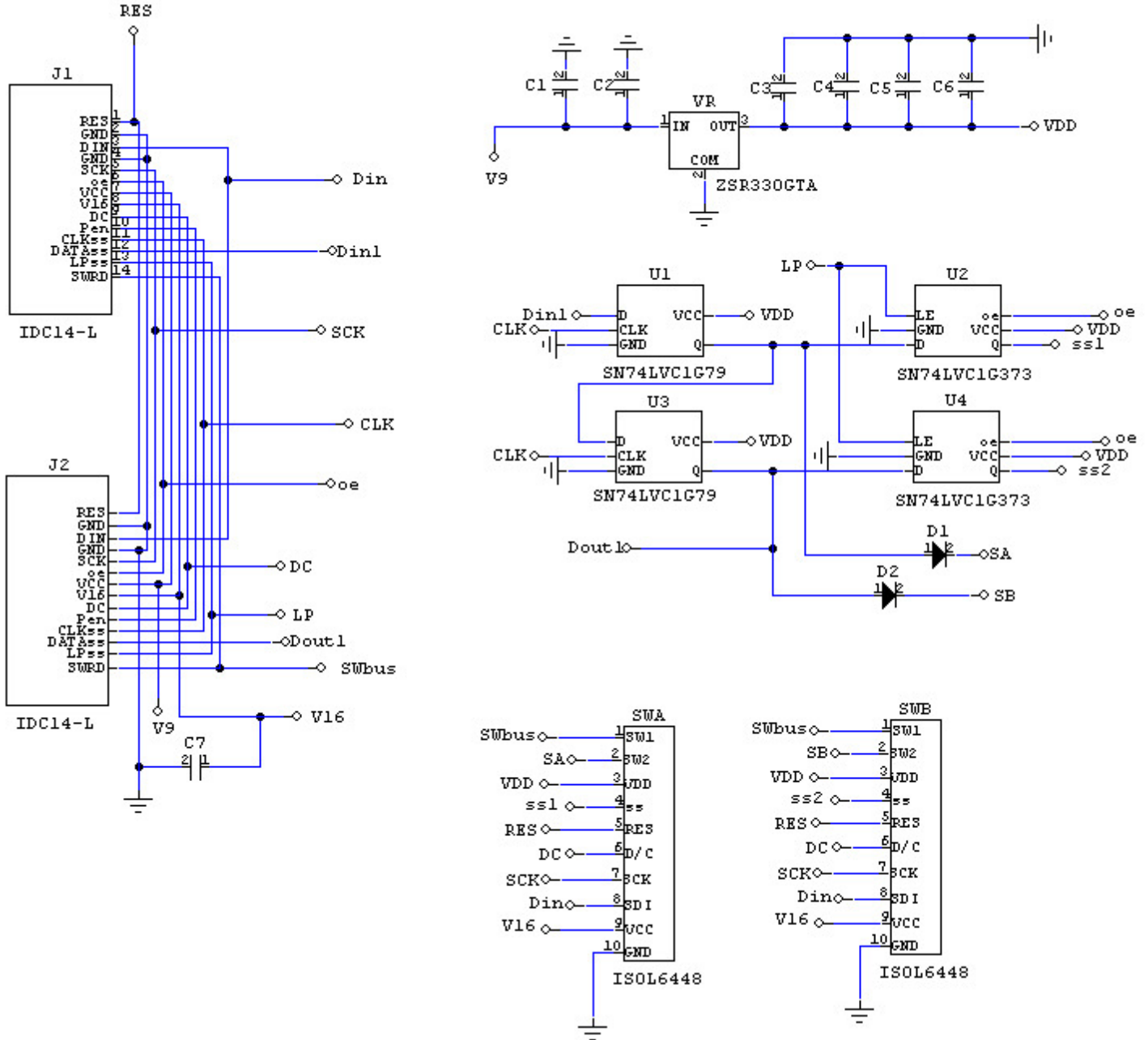

Schematic for IS-L02P1:

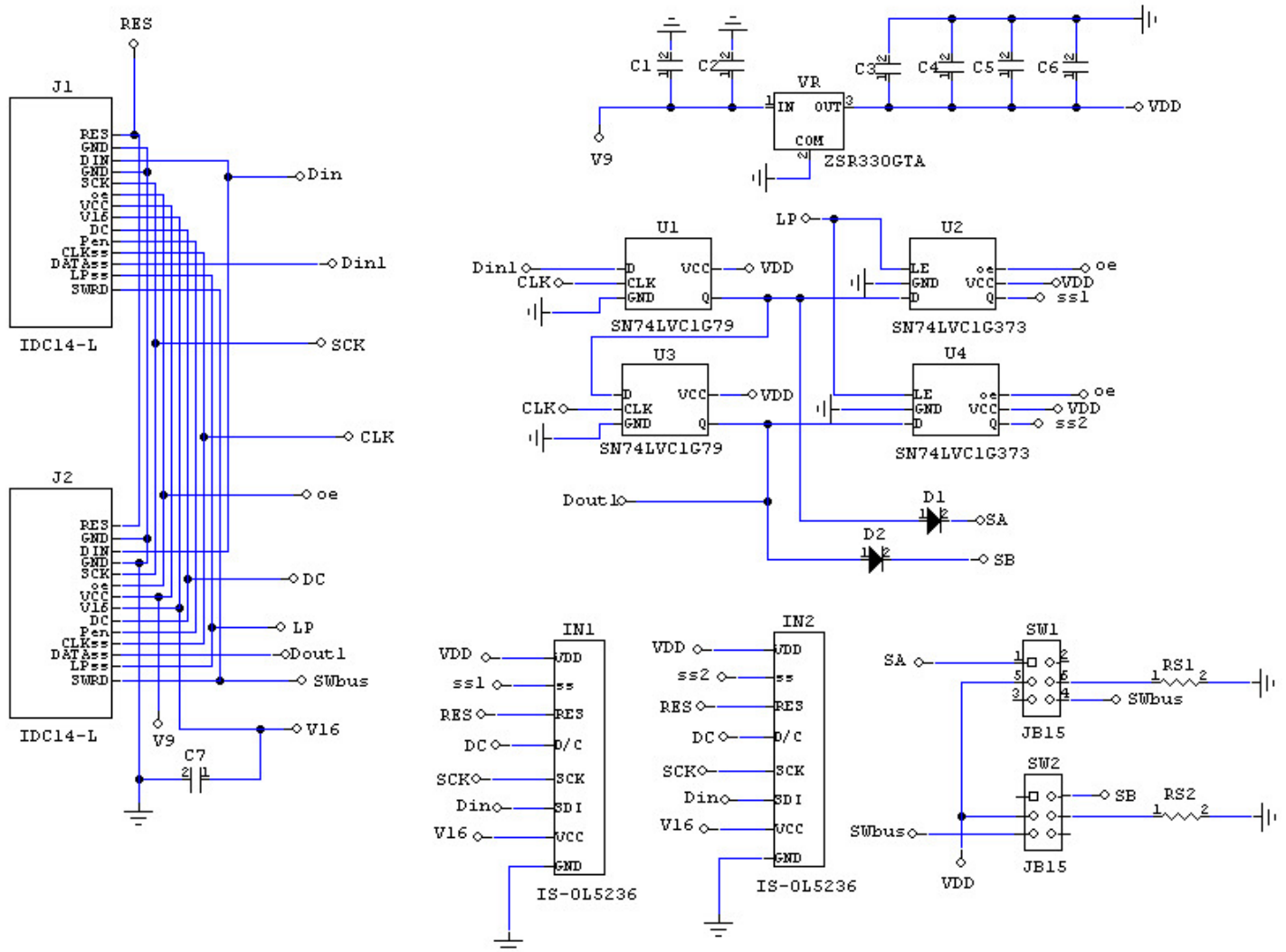

8. Key Terms & Definitions

OLED Module	NKK Switches' OLED SmartSwitches and SmartDisplays.
Host	Any computer, terminal, or other device that can communicate over the RS232 line.
Controller	A PCB assembly that controls one or more logic boards and the switches associated with them. It communicates with a host over the RS232 line.
Logic Board	A PCB assembly with “glue logic” for mounting switches. It is controlled by a controller.
Byte	An eight bit hex value ranging from 00H to FFH (Decimal 0 to 255). The bit format of a byte is: (B7 B6 B5 B4 B3 B2 B1 B0) where B7 is most significant and bit B0 is least significant bit.
Nibble/Hex digit	A four bit value ranging from 0H to FH. A byte consists of two nibbles.
ASCII	A byte value representing a symbol.
Communication Format	<p>There are two formats to transmit a byte:</p> <ol style="list-style-type: none">Hex format - A hex byte is transmitted without any change to it. [xxH] will be used to denote this. All commands and some data are sent by using this format.ASCII HEX format - Each nibble of the byte is converted to ASCII code and sent as a byte. [xxAH] will be used to denote this. For example, the hex byte 5AH is transmitted in two bytes, 35H and 41H. The ASCII value for 5 is 35H and the ASCII value for A is 41H. All addresses and most data are sent using this format.
Address	A two byte value ranging from 0001H to FFFFH representing the 65536 memory locations for pictures and attributes on microSD flash.

Mouser Electronics

Authorized Distributor

Click to View Pricing, Inventory, Delivery & Lifecycle Information:

[NKK Switches:](#)

[IS-L02L1-C](#) [IS-L02P1-C](#)

Компания «Океан Электроники» предлагает заключение долгосрочных отношений при поставках импортных электронных компонентов на взаимовыгодных условиях!

Наши преимущества:

- Поставка оригинальных импортных электронных компонентов напрямую с производств Америки, Европы и Азии, а так же с крупнейших складов мира;
- Широкая линейка поставок активных и пассивных импортных электронных компонентов (более 30 млн. наименований);
- Поставка сложных, дефицитных, либо снятых с производства позиций;
- Оперативные сроки поставки под заказ (от 5 рабочих дней);
- Экспресс доставка в любую точку России;
- Помощь Конструкторского Отдела и консультации квалифицированных инженеров;
- Техническая поддержка проекта, помощь в подборе аналогов, поставка прототипов;
- Поставка электронных компонентов под контролем ВП;
- Система менеджмента качества сертифицирована по Международному стандарту ISO 9001;
- При необходимости вся продукция военного и аэрокосмического назначения проходит испытания и сертификацию в лаборатории (по согласованию с заказчиком);
- Поставка специализированных компонентов военного и аэрокосмического уровня качества (Xilinx, Altera, Analog Devices, Intersil, Interpoint, Microsemi, Actel, Aeroflex, Peregrine, VPT, Syfer, Eurofarad, Texas Instruments, MS Kennedy, Miteq, Cobham, E2V, MA-COM, Hittite, Mini-Circuits, General Dynamics и др.);

Компания «Океан Электроники» является официальным дистрибьютором и эксклюзивным представителем в России одного из крупнейших производителей разъемов военного и аэрокосмического назначения «JONHON», а так же официальным дистрибьютором и эксклюзивным представителем в России производителя высокотехнологичных и надежных решений для передачи СВЧ сигналов «FORSTAR».



JONHON

«JONHON» (основан в 1970 г.)

Разъемы специального, военного и аэрокосмического назначения:

(Применяются в военной, авиационной, аэрокосмической, морской, железнодорожной, горно- и нефтедобывающей отраслях промышленности)

«FORSTAR» (основан в 1998 г.)

ВЧ соединители, коаксиальные кабели, кабельные сборки и микроволновые компоненты:

(Применяются в телекоммуникациях гражданского и специального назначения, в средствах связи, РЛС, а так же военной, авиационной и аэрокосмической отраслях промышленности).



Телефон: 8 (812) 309-75-97 (многоканальный)

Факс: 8 (812) 320-03-32

Электронная почта: ocean@oceanchips.ru

Web: <http://oceanchips.ru/>

Адрес: 198099, г. Санкт-Петербург, ул. Калинина, д. 2, корп. 4, лит. А