

AS3630

8A Supercap Flash Driver

General Description

The AS3630 is an inductive high efficient 4MHz dual DCDC step up converter with several sources. It supports the charging of a Supercap, its voltage balancing and a highly efficient DCDC step up from the Supercap to the LED and from VIN to the LED to power the flash LED with up to 8A. The AS3630 supports the pre-charging of the Supercap (to VIN) to reduce the startup time for the flash without reducing the lifetime of the Supercap.

The system concept supports an immediate torch function without first charging the Supercap.

The AS3630 includes flash timeout, over- undervoltage, overtemperature and LED short circuit protection.

The AS3630 is controlled by an I²C interface for adjustment of the currents and timings, set the end of charge voltage and measure the Supercap and LED parameters through the internal ADC. A dedicated TXMASK/TORCH input can be used for a torch button -or- reducing the battery current if a RF PA is operated at the same time (TX Masking). A hardware enable pin -ON can be used as a reset input.

The AS3630 is available in a space-saving WL-CSP 5x5 balls package measuring only 2.5x2.5x0.6mm and operates over the -30°C to +85°C temperature range.

Figure AS3630 – 1:
Key Benefits and Features

Benefits	Features
Reduce Supercap size	Dual high efficiency boost converter with soft start allows small coils
Instantaneous Torch operation for improved user experience	Immediate Torch functions with charging of the Supercap
Tiny external coils	4MHz fixed frequency DCDC
System Safety	10bit ADC converter for system monitoring with Protection functions: Automatic Flash Timeout timer to protect the LED Overvoltage and undervoltage Protection LED (NTC) and device Overtemperature Protection LED short/open circuit protection
Improved thermal performance (ground = heat sink)	Flash LED(s) cathode connected to ground:

Benefits	Features
Fine control of current to fit to applications	LED currents (fully adjustable by interface) <ul style="list-style-type: none"> • 8A for 33ms and 6A for 120ms (Flash), 2.9mA - 272mA for torch • 1mA-8mA indicator current
Full control and hardware ON pin for easier system integration	I ² C Interface with Interrupt output and ON pin

Applications

The device is ideal for Flash/Torch for mobile phones, DSC and Tablets.

Figure AS3630 – 2:
Typical Operating Circuit

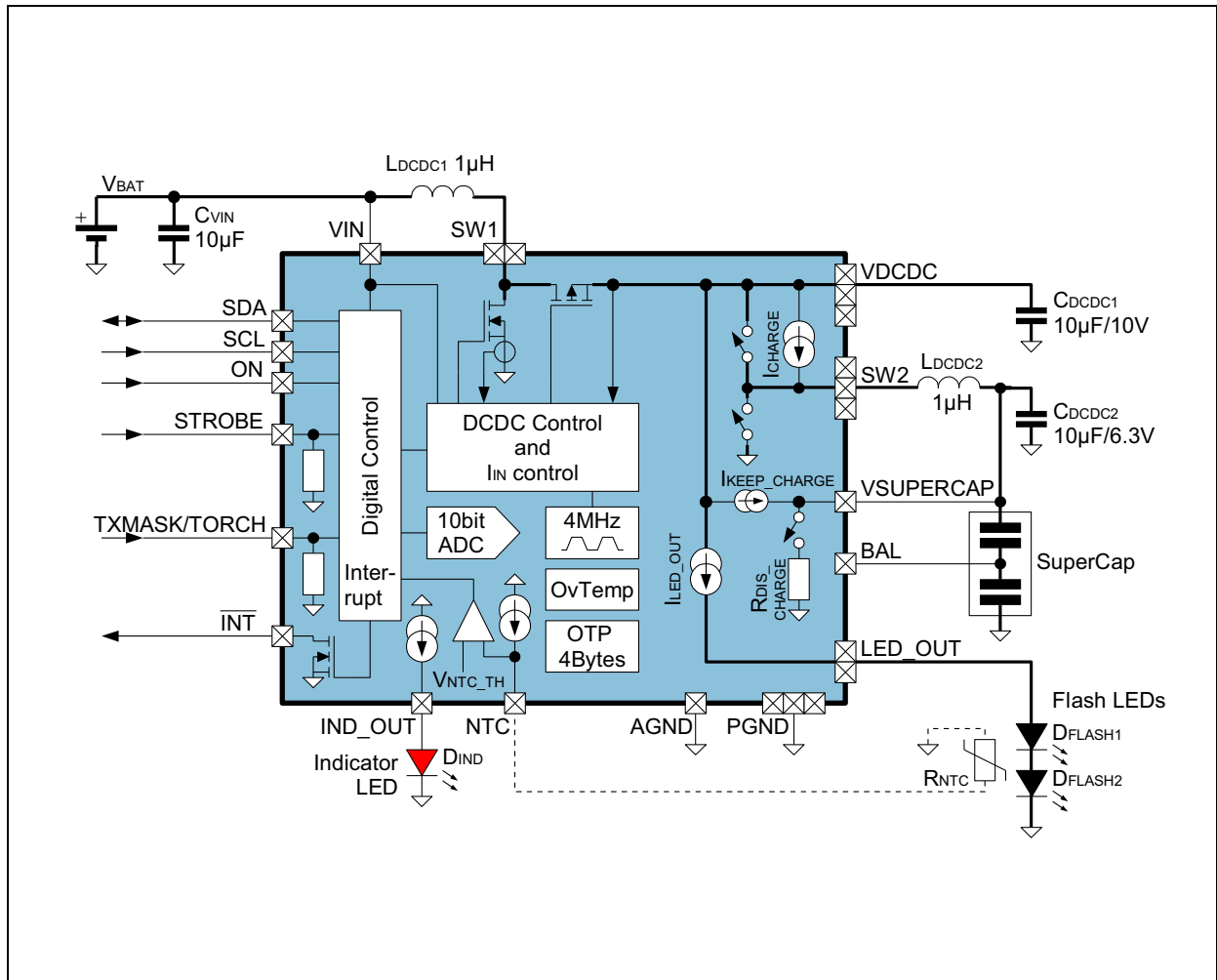

Typical Operating Circuit: Shows the main function blocks of the AS3630.

Pin Assignment

Figure AS3630 – 3:
Pin Assignments (Top View)

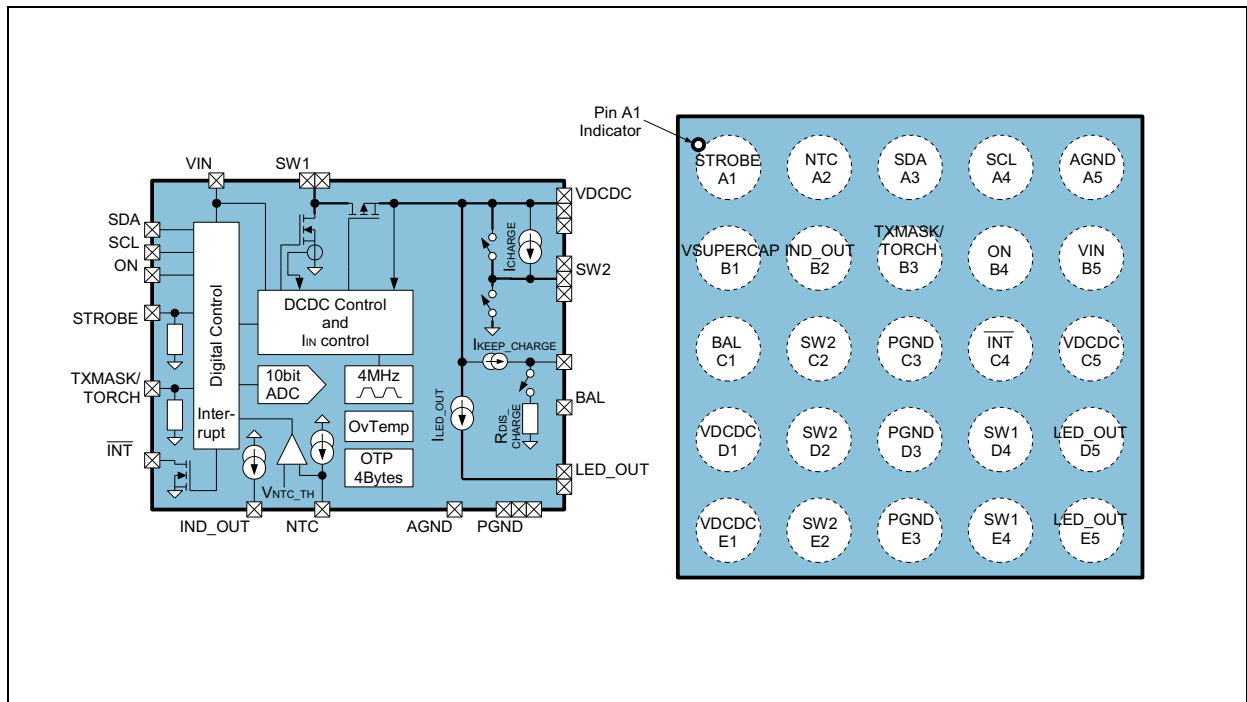

Pin Description

Figure AS3630 – 4:
Pin Description

Pin Number	Pin Name	Description
A1	STROBE	Digital input with pulldown to control strobe time for flash function ¹
A2	NTC	LED temperature sensor input - connect to NTC and connect its GND with a separate ground wire to AGND
A3	SDA ²	Digital input, open drain output - serial data input/output for I ² C interface (needs external pullup resistor)
A4	SCL ²	Digital Input ³ - serial clock input for I ² C mode
A5	AGND	Analog ground - connect to ground (GND)
B1	VSUPERCAP	Supercap connection
B2	IND_OUT	Indicator LED current source output
B3	TXMASK/TORCH	Function 1 <ul style="list-style-type: none"> • “TXMASK” Connect to RF power amplifier enable signal - reduces currents during flash to avoid a system shutdown due to parallel operation of the RF PA and the flash driver. Function 2 <ul style="list-style-type: none"> • “TORCH” Operate torch current level without using the I²C interface to operate the torch without need to start a camera processor (if the I²C is connected to the camera processor).
B4	ON	Digital Input active high - a logic 1 enables of the AS3630; a logic 0 resets the AS3630
B5	VIN	Positive supply voltage input - connect to supply and make a short connection to input capacitor CVIN and to coil L _{DCDC1}
C1	BAL	Supercap balance pin - balances both single capacitors inside the Supercap
C2	SW2	DCDC converter 2 switching node - make a short connection to the coil L _{DCDC2} and connect all SW2 pins together on top plane
C3	PGND	Power ground - connect to ground (GND) and connect all PGND pins together on top plane
C4	$\overline{\text{INT}}$	Open drain interrupt output - active low (needs external pullup resistor)
C5	VDCDC	DCDC converter 1 and 2 output capacitor - make a short connection to CVOUT1 and connect all VDCDC pins together as short as possible

Pin Number	Pin Name	Description
D1	VDCDC	DCDC converter 1 and 2 output capacitor - make a short connection to CVOUT1 and connect all VDCDC pins together as short as possible
D2	SW2	DCDC converter 2 switching node - make a short connection to the coil L_{DCDC2} and connect all SW2 pins together on top plane
D3	PGND	Power ground - connect to ground (GND) and connect all PGND pins together on top plane
D4	SW1	DCDC converter 1 switching node - make a short connection to the coil L_{DCDC1} and connect all SW1 pins together on top plane
D5	LED_OUT	Flash LED current source output and connect all LED_OUT pins together on top plane
E1	VDCDC	DCDC converter 1 and 2 output capacitor - make a short connection to CVOUT1 and connect all VDCDC pins together as short as possible
E2	SW2	DCDC converter 2 switching node - make a short connection to the coil L_{DCDC2} and connect all SW2 pins together on top plane
E3	PGND	Power ground - connect to ground (GND) and connect all PGND pins together on top plane
E4	SW1	DCDC converter 1 switching node - make a short connection to the coil L_{DCDC1} and connect all SW1 pins together on top plane
E5	LED_OUT	Flash LED current source output and connect all LED_OUT pins together on top plane

1. Application Information: The pin STROBE is usually connected directly to the camera processor.
2. When SCL and SDA exchanged, the AS3630 uses a different I²C address and the functionality of SCL/SDA is also exchanged - see "[I²C Address Selection](#)" on page 43.
3. Only input: The AS3630 does not perform clock stretching.

Absolute Maximum Ratings

Stresses beyond those listed under “Absolute Maximum Ratings” may cause permanent damage to the device. These are stress ratings only. Functional operation of the device at these or any other conditions beyond those indicated under “Operating Conditions” is not implied. Exposure to absolute maximum rating conditions for extended periods may affect device reliability.

Figure AS3630 – 5:
Absolute Maximum Ratings

Parameter	Min	Max	Units	Comments
VIN, SDA, SCL, ON, STROBE, TXMASK/TORCH, $\overline{\text{INT}}$, IND_OUT, NTC and BAL to GND	-0.3	+7.0	V	
SDA, SCL, ON, STROBE, TXMASK/TORCH, $\overline{\text{INT}}$, IND_OUT, NTC to GND	-0.3	VIN + 0.3	V	
V _{DCDC} , SW1, SW2, V _{DCDC} , LED_OUT and VSUPERCAP to GND	-0.3	+11	V	
V _{DCDC} to SW1 V _{DCDC} to SW2 V _{DCDC} to LED_OUT VSUPERCAP to BAL	-0.3		V	Diode between <ul style="list-style-type: none"> • V_{DCDC} and SW1 • V_{DCDC} and SW2 • V_{DCDC} and LED_OUT • VSUPERCAP and BAL
AGND, PGND to GND	0.0	0.0	V	Connect AGND and PGND to GND directly below the ball (short connection required)
Input Pin Current without causing latchup	-100	+100 +I _{IN}	mA	Norm: EIA/JESD78
Continuous Power Dissipation (T_A = +70°C)				
Continuous power dissipation		2770	mW	P _T ¹
Continuous power dissipation derating factor		37	mW/°C	P _{DERATE} ²
Electrostatic Discharge				
ESD HBM		±2000	V	Norm: JEDEC JESD22-A114F
ESD MM		±100	V	Norm: JEDEC JESD 22-A115-B

Parameter	Min	Max	Units	Comments
Temperature Ranges and Storage Conditions				
Junction Temperature		+125	°C	+150°C internally limited only during flash (max. 20000s)
Storage Temperature Range	-55	+125	°C	
Humidity	5	85	%	Non condensing
Body Temperature during Soldering		+260	°C	According to IPC/JEDEC J-STD-020
Moisture Sensitivity Level (MSL)	MSL 1			Represents a max. floor life time of unlimited

1. Depending on actual PCB layout and PCB used.
2. P_{DERATE} derating factor changes the total continuous power dissipation (P_T) if the ambient temperature is not 70°C. Therefore for e.g. $T_{\text{AMB}}=85^\circ\text{C}$ calculate P_T at $85^\circ\text{C} = P_T - P_{\text{DERATE}} * (85^\circ\text{C} - 70^\circ\text{C})$

Electrical Characteristics

All limits are guaranteed. The parameters with min and max values are guaranteed with production tests or SQC (Statistical Quality Control) methods.

$V_{VIN} = +2.5V$ to $+4.8V$, $T_{AMB} = -30^{\circ}C$ to $+85^{\circ}C$, unless otherwise specified. Typical values are at $V_{BAT} = +3.7V$, $T_{AMB} = +25^{\circ}C$, unless otherwise specified.

Figure AS3630 – 6:
Electrical Characteristics

Symbol	Parameter	Conditions	Min	Typ	Max	Units
General Operating Conditions						
V_{VIN}	Supply Voltage		2.5	3.7	4.8	V
$I_{SHUTDOWN}$	Shutdown Current	AS3630 off, $V_{BAT} < 3.7V$, $T_{AMB} \leq 50^{\circ}C$, ON=0		0.5	2.0	μA
$I_{STANDBY}$	Standby Current	AS3630 off, $V_{BAT} < 3.7V$, $T_{AMB} \leq 50^{\circ}C$, ON=1		1.0	10	μA
$I_{PRE_CHARGE_LOW_POWER}$	Supercap pre-charging current	<code>mode_setting</code> = Supercap pre-charge and <code>charge_current</code> = 00b		2		μA
T_{AMB}	Operating Temperature		-30	25	85	$^{\circ}C$
DCDC1/2 Step Up Converter						
V_{DCDC}	DCDC Boost output Voltage (pin V_{DCDC})	DCDC1 (L_{DCDC1}) and/or DCDC2 (L_{DCDC2}) is in operation			10	V
η	Efficiency	DCDC1 (L_{DCDC1}) or DCDC2 (L_{DCDC2})		90		%
f_{CLK}	Operating Frequency	All internal timings are derived from this oscillator	-10%	4.0	+10%	MHz
max_duty_{DCDC}	DCDC1/2 maximum duty cycle			84		%
R_{SW_P1}	DCDC Switch SW1 - V_{DCDC}			100		$m\Omega$
R_{SW_N1}	DCDC Switch SW1 - GND			100		$m\Omega$
R_{SW_P2}	DCDC Switch SW2 - V_{DCDC}			70		$m\Omega$
R_{SW_N2}	DCDC Switch SW2 - GND			100		$m\Omega$

Symbol	Parameter	Conditions	Min	Typ	Max	Units	
Supercap Charger / Discharge							
V _{SUPERCAP_EOC} ¹	End of charge voltage for Supercap	Programmable in 90mV steps by register end_of_charge_volt above 5.5V max. 60000s during lifetime of AS3630	0	4.469	4.57	4.671	V
			1	4.557	4.66	4.763	V
			2	4.646	4.75	4.855	V
			3	4.724	4.83	4.936	V
			4	4.820	4.93	5.036	V
			5	4.900	5.01	5.12	V
			6	4.995	5.11	5.219	V
			7	5.082	5.2	5.31	V
			8	5.170	5.29	5.402	V
			9	5.258	5.38	5.494	V
			Ah	5.345	5.47	5.585	V
			Bh	5.433	5.56	5.677	V
			Ch	5.526	5.65	5.774	V
			Dh	5.616	5.74	5.868	V
			Eh	5.704	5.83	5.96	V
Fh	5.793	5.92	6.053	V			
I _{SUPERCAP_CHARGE}	Pre-charging current of Supercap ²	Pre-charging and transition (to charge) of Supercap - see Supercap Charging/Discharge/Pre-charge to VIN ; final charging to V _{SUPERCAP_EOC} is controlled by coil1_peak	charge_current = 00b, low quiescent current mode	100	200	300	mA
			01b	380	500	650	
			10b	570	750	975	
			11b	760	1000	1300	
I _{KEEP_CHARGE}	Keeping Supercap charged current	During torch, charge or PWM operation keep V _{SUPERCAP} charged if keep_sc_charged = 1		10		mA	
R _{DIS_CHARGE}	Discharge resistance for V _{SUPERCAP}	mode_setting = 001b / shutdown and discharge Supercap		250*2		Ω	

Symbol	Parameter	Conditions	Min	Typ	Max	Units	
LED Current Sources							
I _{LED_OUT}	LED_OUT Current set by <code>led_current</code>	Limited lifetime max. 20000s, <code>mode_setting</code> = flash operation; current specified for each of the two flash LEDs	10		(2x) 3000	mA	
		<code>mode_setting</code> = torch operation	10		460		
		<code>mode_setting</code> = PWM operation duty cycle defined by <code>led_out_pwm</code>	10		303.9 * duty cycle		
			Accuracy, ΔI	-10		+10	%
I _{LED_OUT_RIPPLE}	LED_OUT ripple current	I _{LED} =2500mA, BW=20MHz		200		mApp	
V _{FLASH_COMP}	Flash current source voltage compliance	Minimum Voltage between VSUPERCAP and LED_OUT to generate the programmed current (<code>led_current</code>)	<code>led_current_range</code> = 00b or 01b		0.4	V	
		10b		0.5			
I _{IND_OUT}	Indicator Current	Set by <code>ind_current</code> in 1mA steps	Range	1.0		8.0	mA
			Accuracy, ΔI	-20		+20	%
V _{LED_OUT}	LED_OUT-forward voltage measured on pin LED_OUT	<code>led_current_range</code> = 00b...10b	2.6 x2		4.4 x2	V	
		<code>led_current_range</code> = 11b (4A)	2.6 x2		4.325 x2	V	
ADC							
Resolution				10		bits	
Range	ADC input range; channel selected by <code>ADC_channel</code>	ADC Code	'000h'		'3FFh'		
		BAL, VIN, IND_OUT, PGND, TXMASK/TORCH, STROBE, INT and ON	0.0		5.866	V	
		VSUPERCAP	0.0		6.666	V	
		NTC	0.0		2.2	V	
		V _{DCDC}	0.0		11	V	
		LED_OUT			12.1		
		T _{junc} (AS3630 junction temperature, in °C) = round (((4 * <code>ADC_D9-D2</code> + <code>ADC_D1-D0</code>) - 324) * -1.05042)					

Symbol	Parameter	Conditions		Min	Typ	Max	Units
Averaging	ADC internal averaging filter	Number of conversion per measurement (averaged); measurements can be started immediately, at begin of flash and end of flash - see ADC_convert			4		
Protection and Fault Detection Functions							
$V_{VOUTMAX}$	V_{DCDC} overvoltage protection	DCDC Converter Overvoltage Protection		9.3		10.0	V
I_{LDCDC1}	Current Limit for coil L_{DCDC1} (Pin SW1) measured at 75% PWM duty cycle ³	Set by coil1_peak and coil1_txmask_curr_red during TXMask	Range	500		3500	mA
			Accuracy, ΔI	-10		+10	%
I_{LDCDC2}	Current Limit for coil L_{DCDC2} (Pin SW1) measured at 75% PWM duty cycle ³	Set by coil2_peak	Range	1000		6000	mA
			Accuracy, ΔI	-10		+10	%
$V_{LEDSHORT}$	Flash LED short circuit detection voltage	Voltage measured on pin LED_OUT monitored once the LED_OUT current is at or above a minimum current - " Short/Open LED Protection - fault_led " on page 35			1.45		V
T_{OVTEMP}	Overtemperature Protection	Junction temperature			144		°C
T_{OVTEMP} HYST	Overtemperature Hysteresis				5		°C
$t_{FLASHTIMEOUT}$	Flash Timeout Timer	Set by flash_timeout	Range	4		760	ms
			Accuracy, Δt	-10% -2ms		+10% +2ms	
V_{UVLO}	Undervoltage Lockout	Falling V_{VIN}		2.3	2.4	2.5	V
		Rising V_{VIN}		$V_{UVLO} + 0.05$	$V_{UVLO} + 0.1$	$V_{UVLO} + 0.15$	V

Symbol	Parameter	Conditions	Min	Typ	Max	Units	
Protection and Fault Detection Functions - NTC							
I _{NTC}	NTC Current Source	Adjustable by NTC _{current} in 40µA steps, V(NTC) ≤ 1.7V	0		off		
			1	34.4	40	45.6	µA
			2	72	80	88	µA
			3	110	120	130	µA
			4	147	160	173	µA
			5	184	200	216	µA
			6	220	240	260	µA
			7	257	280	303	µA
			8	294	320	346	µA
			9	331	360	389	µA
			Ah	368	400	432	µA
			Bh	404	440	476	µA
			Ch	441	480	519	µA
			Dh	478	520	562	µA
			Eh	515	560	605	µA
Fh	552	600	648	µA			
V _{NTC_TH}	Threshold for overtemperature	If ntc_on=1 and the voltage on NTC drops below V _{NTC_TH} , any flash/torch or PWM operation of LED_OUT is stopped		1.0		V	
Digital Interface							
V _{IH}	High Level Input Voltage	Pins SDA, SCL, ON, STROBE and TXMASK/TORCH	1.28		V _{VIN}	V	
V _{IL}	Low Level Input Voltage		0.0		0.5	V	
V _{OL}	Low Level Output voltage	Pin $\overline{\text{INT}}$ and SDA at 2mA	0		0.2	V	
I _{LEAK}	Leakage current V _{VIN} or GND	Pins SDA, SCL, ON	-1.0		+1.0	µA	
R _{PULLDOWN}	Pulldown current to GND	Pins TXMASK/TORCH, STROBE	1.8V on pad	35		kΩ	
t _{DEBTORCH}	torch debounce time	TXMASK/TORCH input in torch mode		7.5		ms	

Symbol	Parameter	Conditions	Min	Typ	Max	Units
tDEBTXMASK	debounce timer	TXMASK/TORCH input in TXMask mode - see "TXMASK" on page 28		2.1		μs
I²C Mode Timings (page 14)						
f _{SCLK}	SCL Clock Frequency		0		400	kHz
t _{BUF}	Bus Free Time Between a STOP and START Condition		1.3			μs
t _{HD:STA}	Hold Time (Repeated) START Condition ⁴		0.6			μs
t _{LOW}	LOW Period of SCL Clock		1.3			μs
t _{HIGH}	HIGH Period of SCL Clock		0.6			μs
t _{SU:STA}	Setup Time for a Repeated START Condition		0.6			μs
t _{HD:DAT}	Data Hold Time ⁵		0		0.9	μs
t _{SU:DAT}	Data Setup Time ⁶		100			μs
t _R	Rise Time of Both SDA and SCL Signals		20 + 0.1C _B		300	ns
t _F	Fall Time of Both SDA and SCL Signals		20 + 0.1C _B		300	ns
t _{SU:STO}	Setup Time for STOP Condition		0.6			μs
C _B	Capacitive Load for Each Bus Line	C _B — total capacitance of one bus line in pF			400	pF
C _{I/O}	I/O Capacitance (SDA, SCL)				10	pF

1. In pre-charge the Supercap is always charged close to V_{VIN}; therefore VSUPERCAP_EOC ≥ V_{VIN} is possible
2. In order to reduce the total charging time of the Supercap, it is recommended to keep the Supercap pre-charged at VIN (can be enabled/disabled by mode_setting)
3. Due to slope compensation of the current limit, the current limit changes with duty cycle
4. After this period, the first clock pulse is generated.
5. A device must internally provide a hold time of at least 300ns for the SDA signal (referred to the V_{IHMIN} of the SCL signal) to bridge the undefined region of the falling edge of SCL.
6. A fast-mode device can be used in a standard-mode system, but the requirement t_{SU:DAT} = to 250ns must then be met. This is automatically the case if the device does not stretch the LOW period of the SCL signal. If such a device does stretch the LOW period of the SCL signal, it must output the next data bit to the SDA line t_R max + t_{SU:DAT} = 1000 + 250 = 1250ns before the SCL line is released.

Timing Diagrams

Figure AS3630 – 7:
I²C Mode Timing Diagram

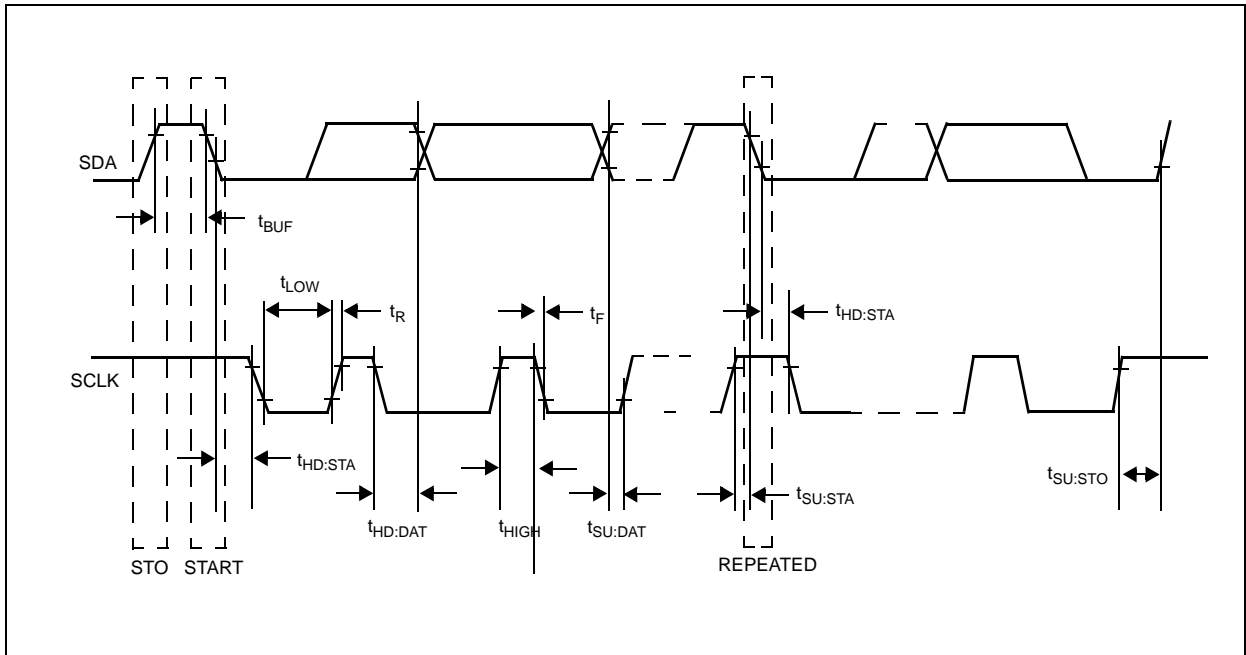

Typical Operating Characteristics

All measurements are performed at $V_{VIN}=3.7V$ and $T_{AMB}=25^{\circ}C$.
LED = LXCL-LW07.

Figure AS3630 – 8:
Efficiency vs. Supply Voltage V_{IN} for DCDC1

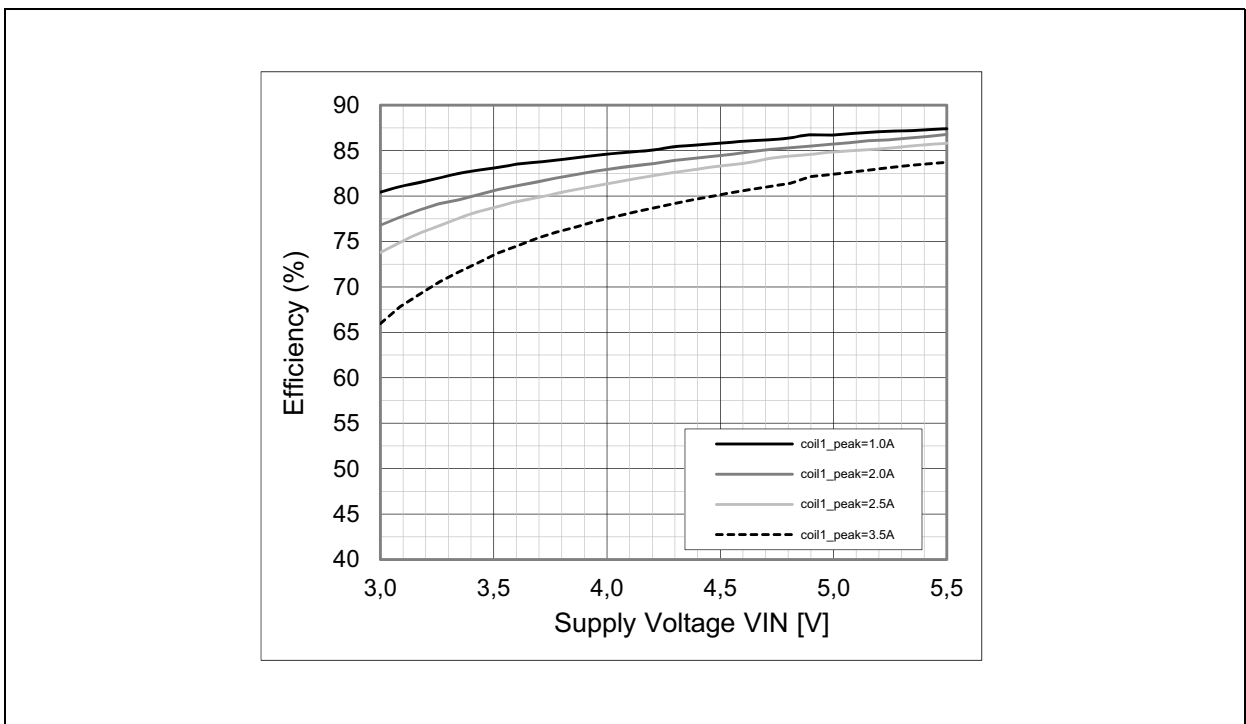

Efficiency vs. Supply Voltage: Shows efficiency (P_{OUT}/P_{IN}) of internal DCDC1 (V_{IN} to V_{DCDC}) vs. different supply

voltages.

Figure AS3630 – 9:
Efficiency vs. V_{SUPERCAP} for DCDC2

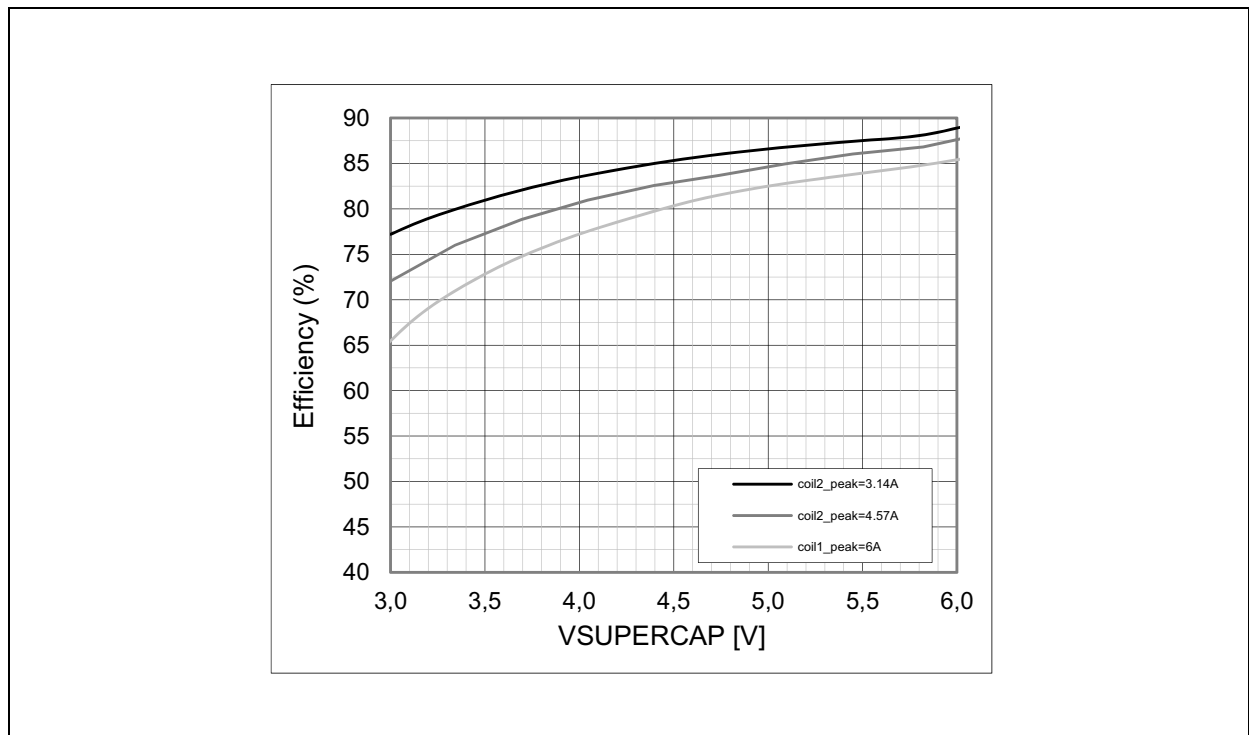

Efficiency vs. Supply Voltage: Shows efficiency ($P_{\text{OUT}}/P_{\text{IN}}$) of internal DCDC2 (V_{SUPERCAP} to V_{DCDC}) vs. voltage on V_{SUPERCAP} while discharging from 6V down to 3V.

**Figure AS3630 – 10:
Supercap Charging Cycle**

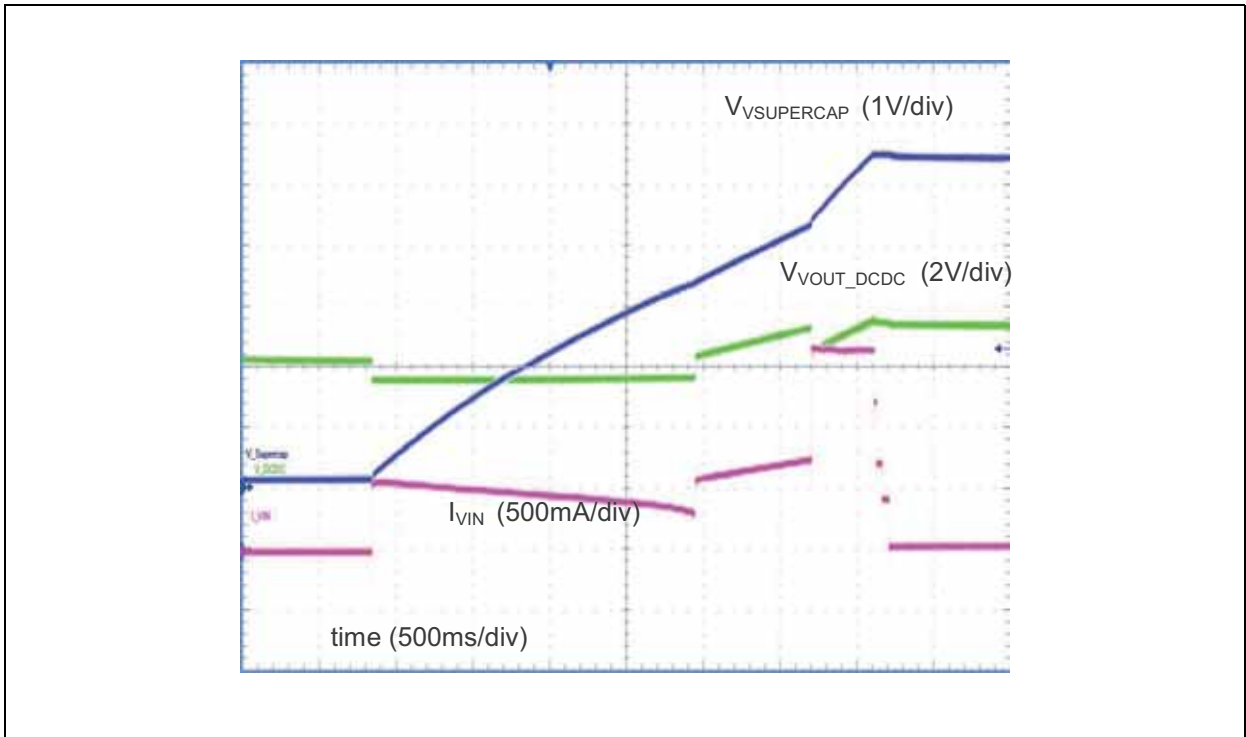

Supercap charging cycle: Shows all phases for charging of the Supercap starting from Pre-charge to transitions to charge until end of charge.

**Figure AS3630 – 11:
Complete Flash Cycle**

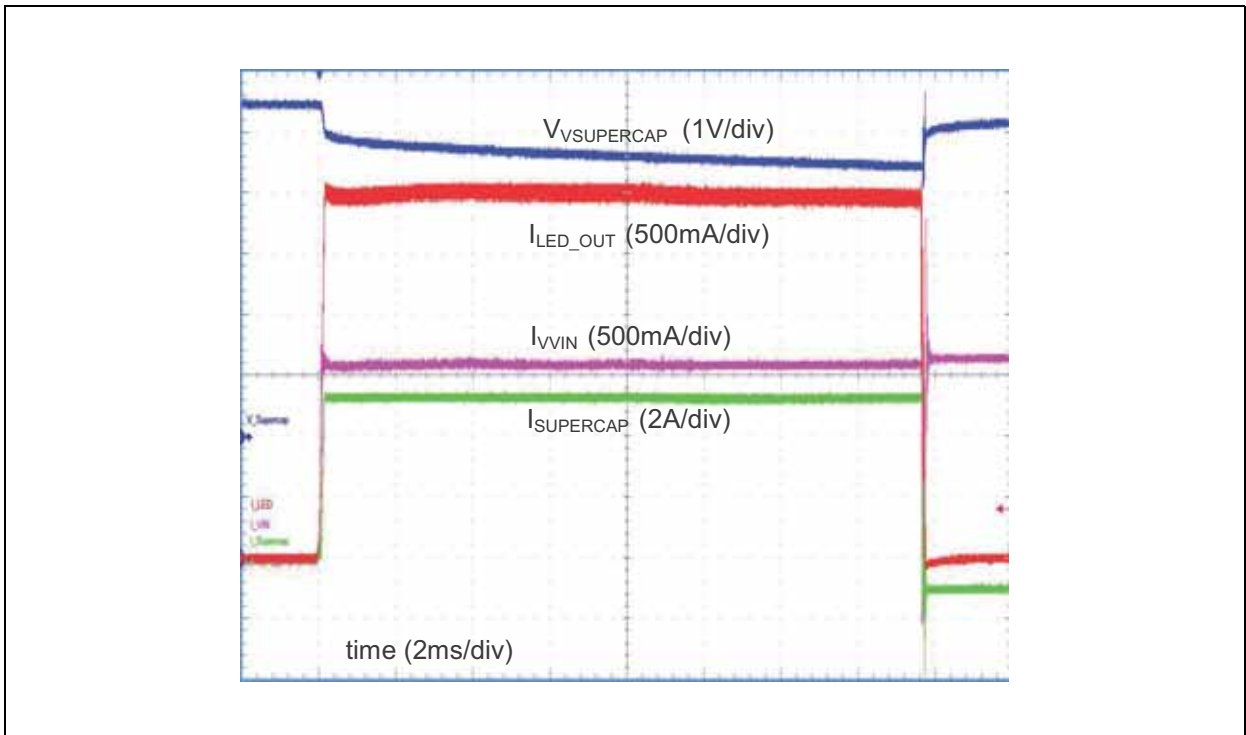

Complete flash cycle: Shows a complete LED flash cycle, flash time=16ms, $I_{LED_OUT}=3A$, automatic re-charge enabled at end of flash cycle.

**Figure AS3630 – 12:
Startup of Flash Cycle**

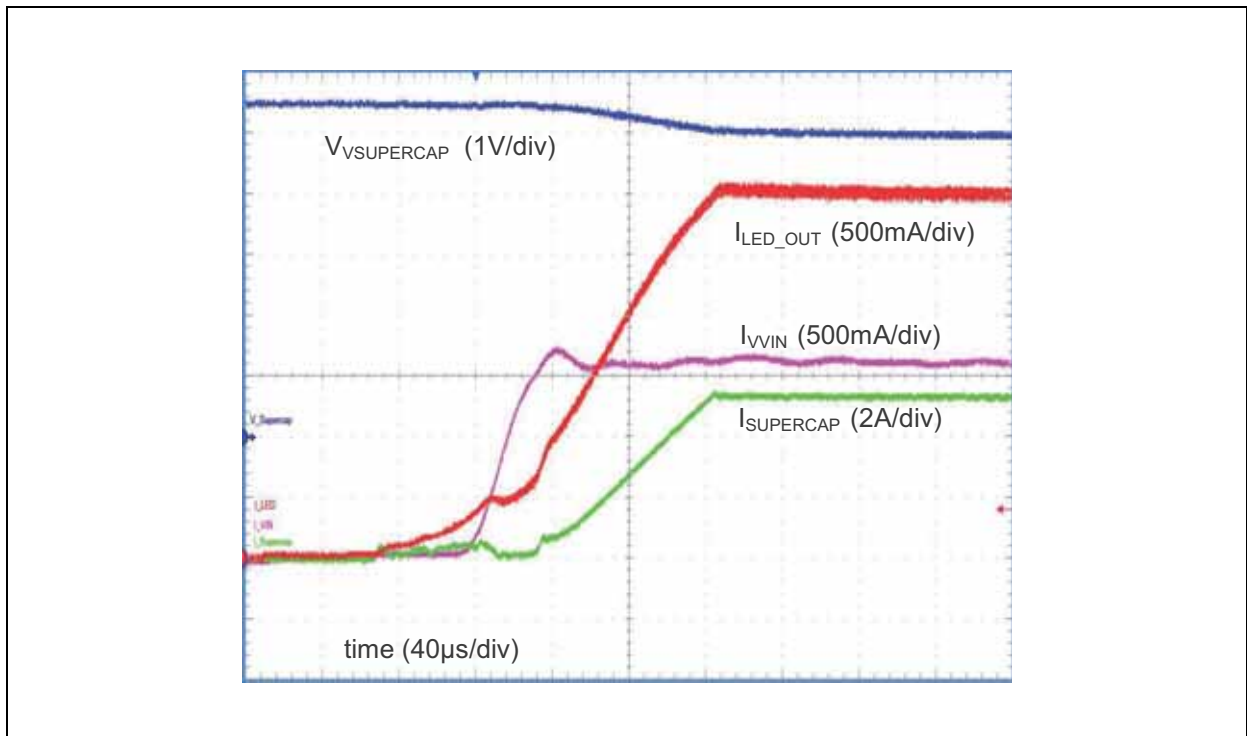

Startup flash cycle: Shows detailed (zoomed) of startup of a flash cycle, $I_{LED_OUT}=3A$.

**Figure AS3630 – 13:
Shutdown of Flash Cycle**

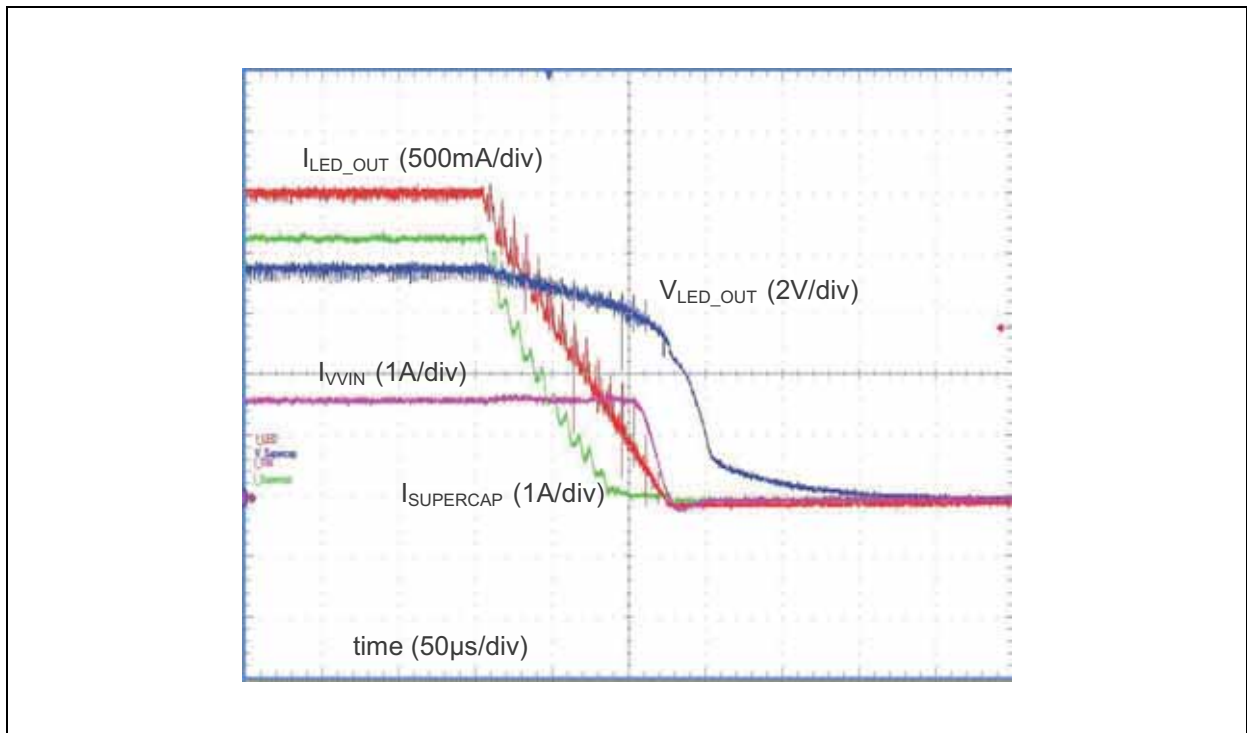

Shutdown flash cycle: Shows detailed (zoomed) of rampdown of a flash cycle, $I_{LED_OUT}=2.5A$.

Figure AS3630 – 14:
Torch Cycle

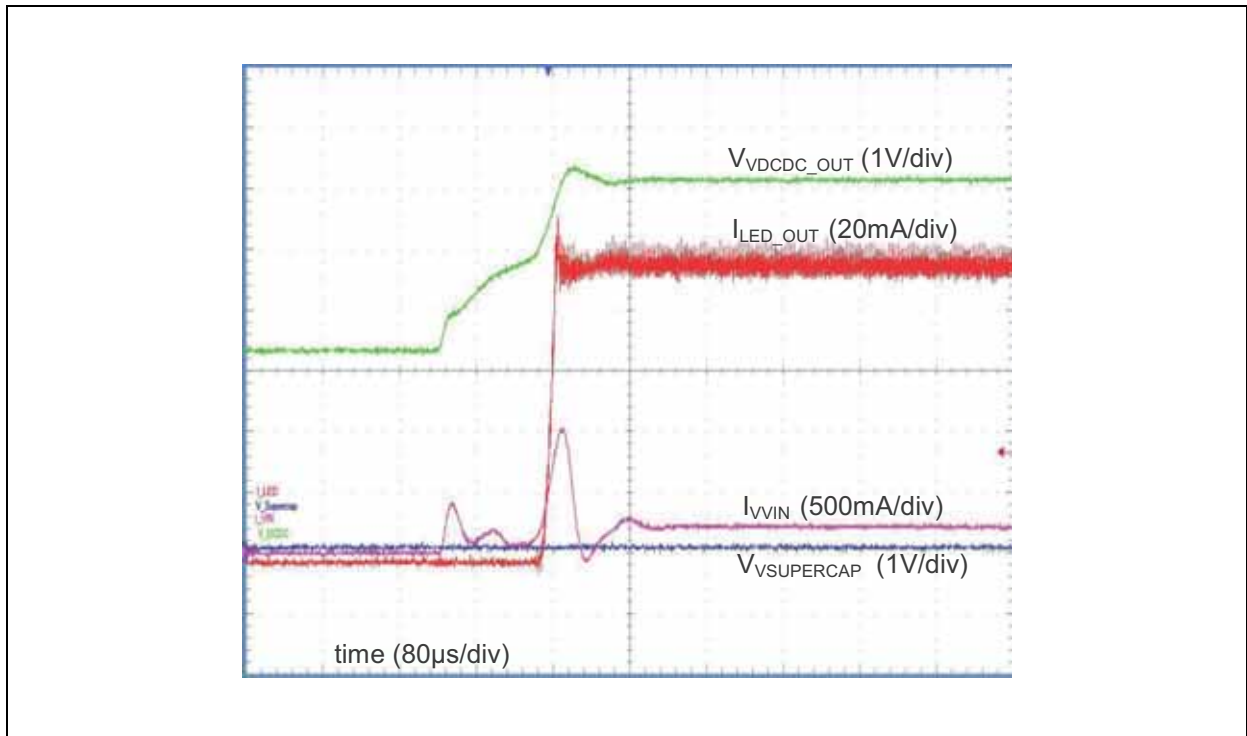

Torch cycle: Shows a torch operation. To operate the torch no charging of the Supercap is required (see voltage on $V_{SUPERCAP}$), $I_{LED_OUT}=100mA$.

Figure AS3630 – 15:
ILED_OUT Ripple Waveform

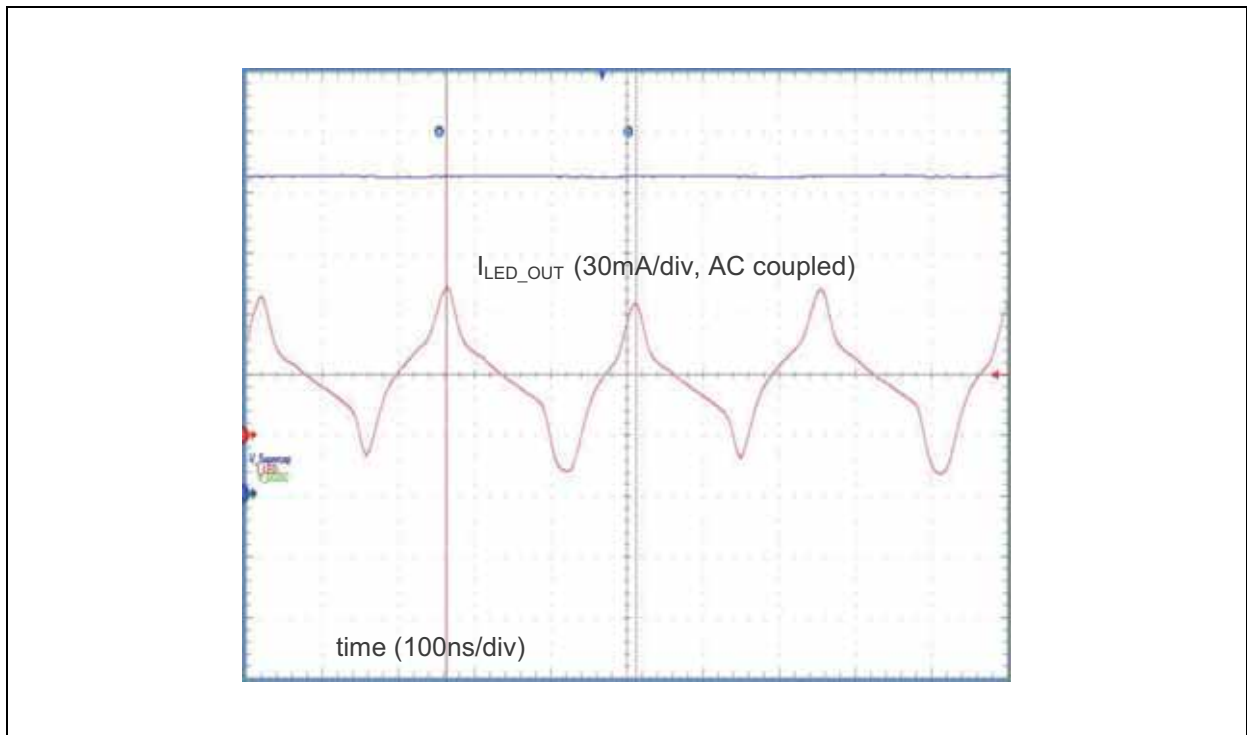

ILED_OUT ripple: Current ripple measured on ILED during flash with $I_{LED_OUT}=2A$.

**Figure AS3630 – 16:
Open LED Detection Waveform**

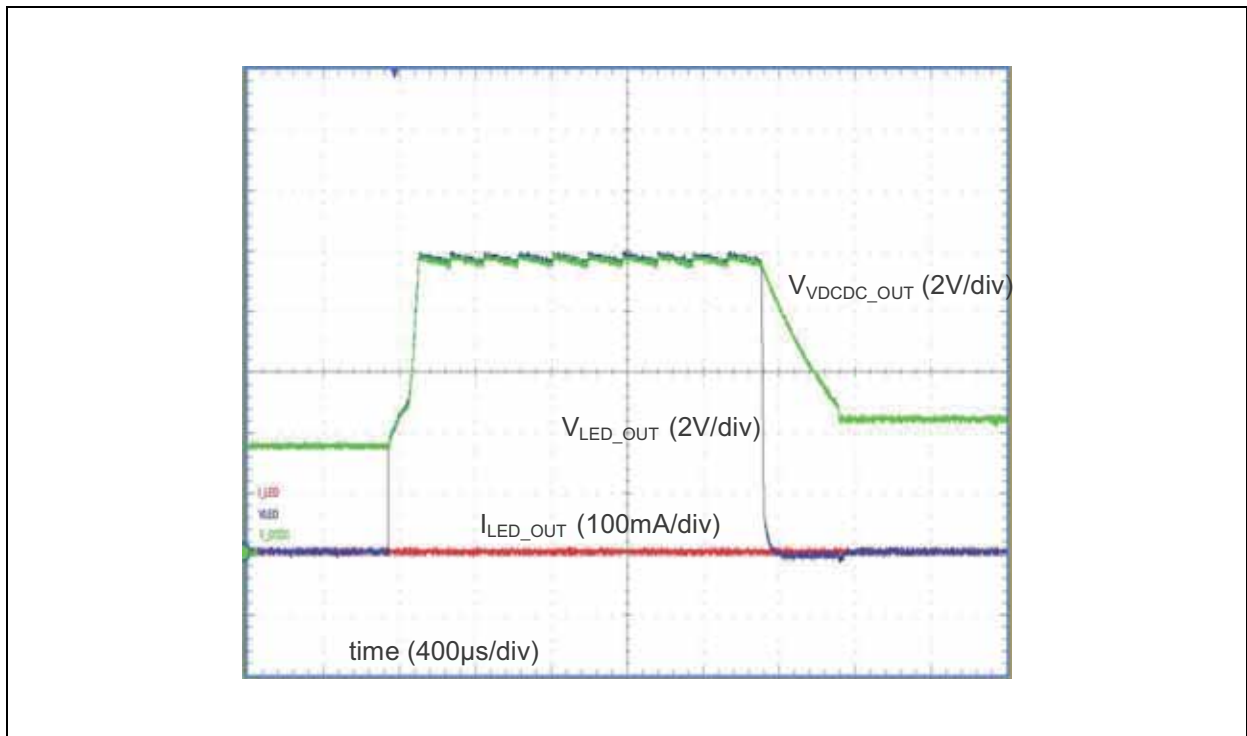

Open LED detection: Detailed measurement for detection of an open LED (LED disconnected) in torch mode.

**Figure AS3630 – 17:
Short LED Detection Waveform**

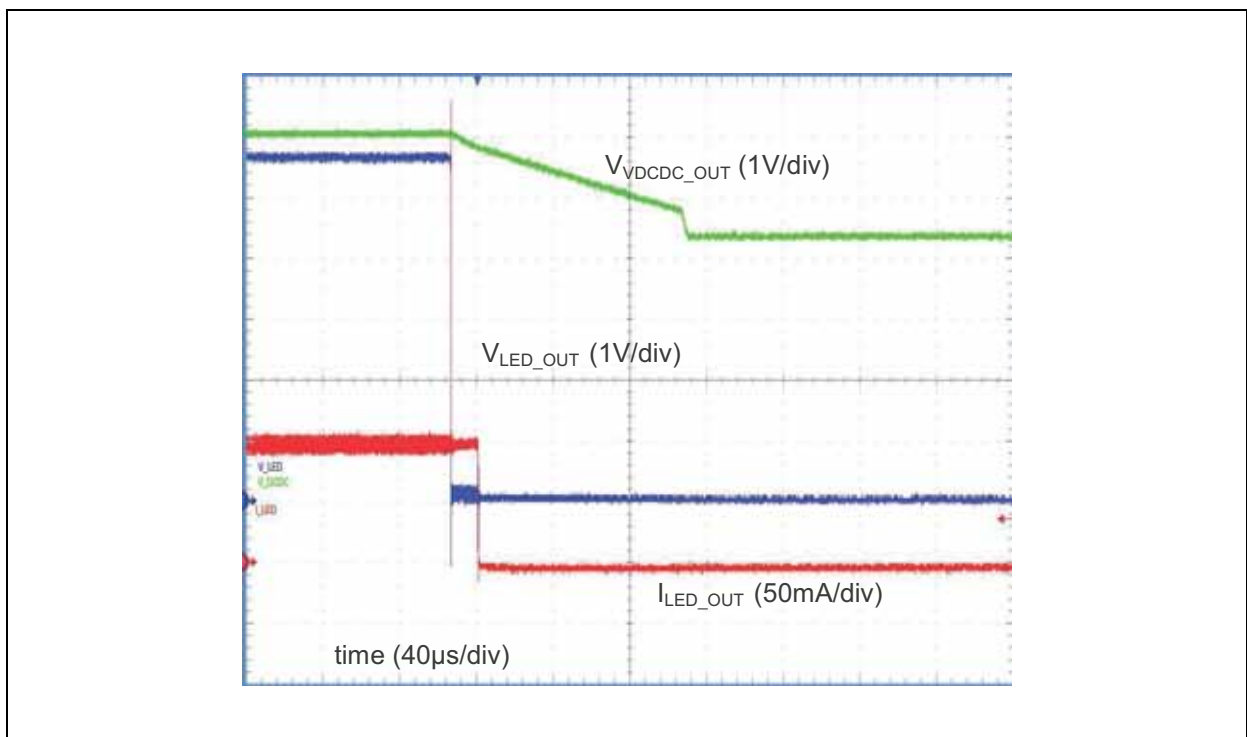

Short LED detection: Detailed measurement for detection of a shorted LED (short during operation).

Figure AS3630 – 18:
Switching Waveform

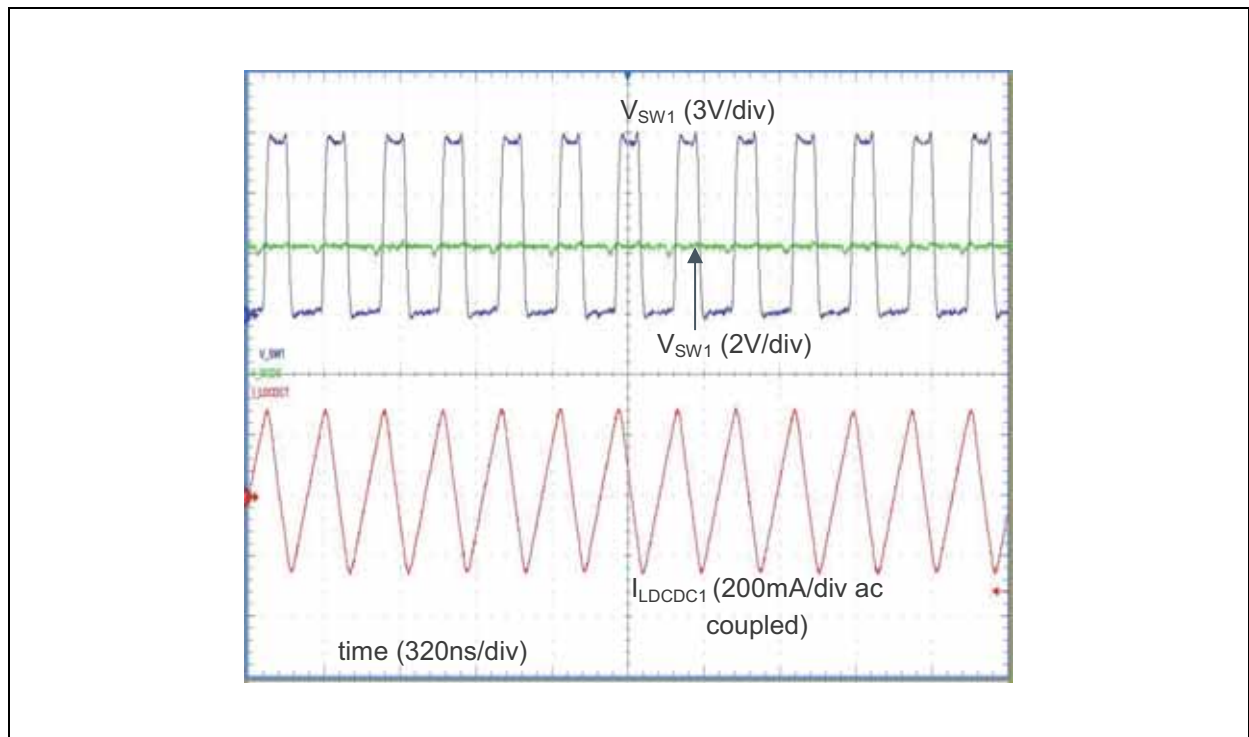

Switching waveform: Detailed measurement of the DCDC converters in operation during flash.

Detailed Descriptions

The AS3630 is a highly efficient dual DCDC Supercap charger charging and balancing the Supercap and operating a LED flash at up to 8A current.

The principle of operation of a AS3630 is as follows:

1. Charge the Supercap on VSUPERCAP to e.g. 5.5V - see [Supercap Charging/Discharge/Pre-charge to VIN](#)
2. Torch (or PWM) operation of the LED does not depend on a charge Supercap - see ["Torch/PWM Operation" on page 25](#).
3. Use DCDC1 to step up from VIN to V_{DCDC} to source one part of the LED_OUT current; in parallel use DCDC2 to step up from -VSUPERCAP to V_{DCDC} to source the remaining part of the flash current - see [Flash Operation](#).

Using this approach a very high current flash operation can be performed using considerable low current from the battery (usually batteries have a defined strict current limit, so the full flash current cannot be supplied directly from the battery only).

Supercap Charging/Discharge/Pre-charge to VIN

The charging of the Supercap is performed in following steps:

- **Pre-Charge** - (see Figure below): Charge the Supercap close to VIN - initiated by setting `mode_setting` = Supercap pre-charge^{1, 2}:

The switch between SW1 and V_{DCDC} is closed and I_{CHARGE} (set by `charge_current`) is used to control the charging current. Use `charge_current=00b` for a special low power mode only consuming $I_{PRE_CHARGE_LOW_POWER}$.

1. This mode is usually used during standby of the system - the Supercap is kept at VIN; this will reduce the charging time, when the camera is operated and the Supercap has to be charged to its final end of charge voltage (e.g. 5.5V)

2. In pre-charge the Supercap is always charged close to V_{VIN} ; therefore `VSUPERCAP_EOC` $\geq V_{VIN}$

Figure AS3630 – 20:
Supercap Charging

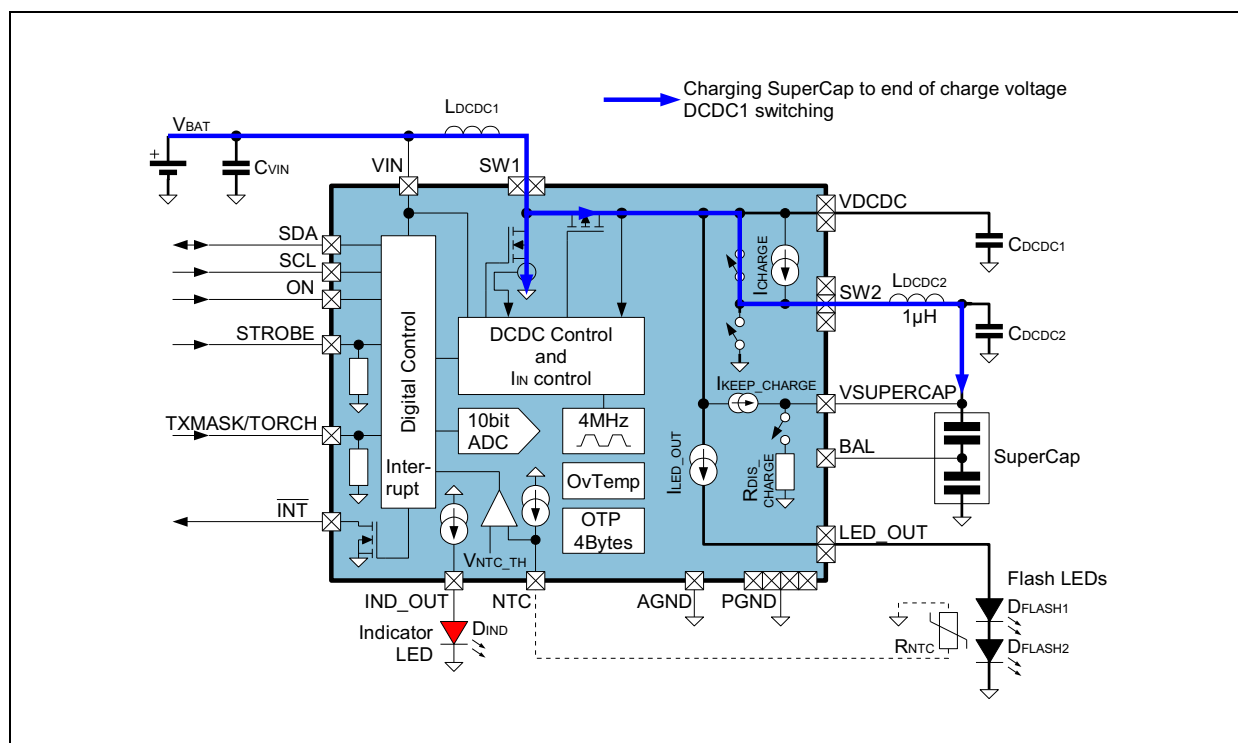

- Charging** - (see Figure above): Once the voltage on VSUPERCAP \geq VIN and `mode_setting = "Supercap charge"`, the main charging can start: The DCDC1 converter is operated and the switch between V_{DCDC} and SW2 is closed. The charging current in this phase is defined by the L_{DCDC1} peak current limit (programmed by `coil1_peak`). Once the voltage on VSUPERCAP reaches `end_of_charge_voltage`⁴, the peak current through L_{DCDC1} is reduced to 500mA. Charging is finished when the voltage on VSUPERCAP again reaches `end_of_charge_voltage`. Then the flash `status_eoc` is set and if enabled by `status_eoc_mask`, INT is pulled low. If `keep_sc_charged=1`, AS3630 will continuously check the voltage on VSUPERCAP if it drops below `end_of_charge_voltage` and automatically recharge the Supercap with 5mA.
- Keep charge**: Even in torch or PWM operation⁵ of the LED connected to LED_OUT the charge on VSUPERCAP can be maintained by setting `keep_sc_charged=1`. Then the current source I_{KEEP_CHARGE} will be used to charger VSUPERCAP from V_{DCDC} (without exceeding `end_of_charge_voltage`).

4. In pre-charge the Supercap is always charged close to VVIN; therefore VSUPERCAP_EOC \geq VVIN

5. In these modes DCDC2 is not used as LED_OUT can be driven directly with DCDC1 from VIN.

- **Shutdown:** Setting `mode_setting`="shutdown or external torch mode (leave Supercap charged)" will keep the Supercap charged and disables the balancing circuit. It can be forced on if `bal_force_on` is set. If the voltage on V_{DCDC} is above 5.35V, the Supercap will be discharged until V_{DCDC} is below 5.3V before shutdown mode is entered.
- **Shutdown and Discharge:** Setting `mode_setting`="shutdown and discharge Supercap" will slowly discharge the Supercap through `RDIS_CHARGE`⁶.
- **Pre-Charge after Charge or Flash:** Setting `mode_setting`="pre charge Supercap (to VIN)" will discharge the Supercap to approximately $V_{VIN}-0.3V$ by using `RDIS_CHARGE`. Afterwards the Supercap is charged to V_{VIN} as shown in [Figure 19](#).

Note: If the Supercap is charged above 5.5V it will be discharged to 5.5V even if the mode is set to "shutdown or external torch mode (leave Supercap charged)" to protect the Supercap. If during pre-charge, transition or charging operation, the junction temperature exceed T_{OVTEMP} the operation is temporarily stopped and automatically resumes, when the junction temperature has dropped below $T_{OVTEMP}-T_{OVTEMPHYST}$.

The Supercap balancing circuit keeps both parts of the Supercap at the same voltage level - see [Balancing Circuit - Pin BAL](#).

6. Implemented by a resistor between `VSUPERCAP` and `BAL` and another resistor between `BAL` and `GND`.

Torch/PWM Operation

Due to its concept, a torch or PWM operation can be performed without even charging the Supercap (this allows instantaneous video light or torch light):

Figure AS3630 – 21:
Immediate Torch (=Video Light) or PWM Operation

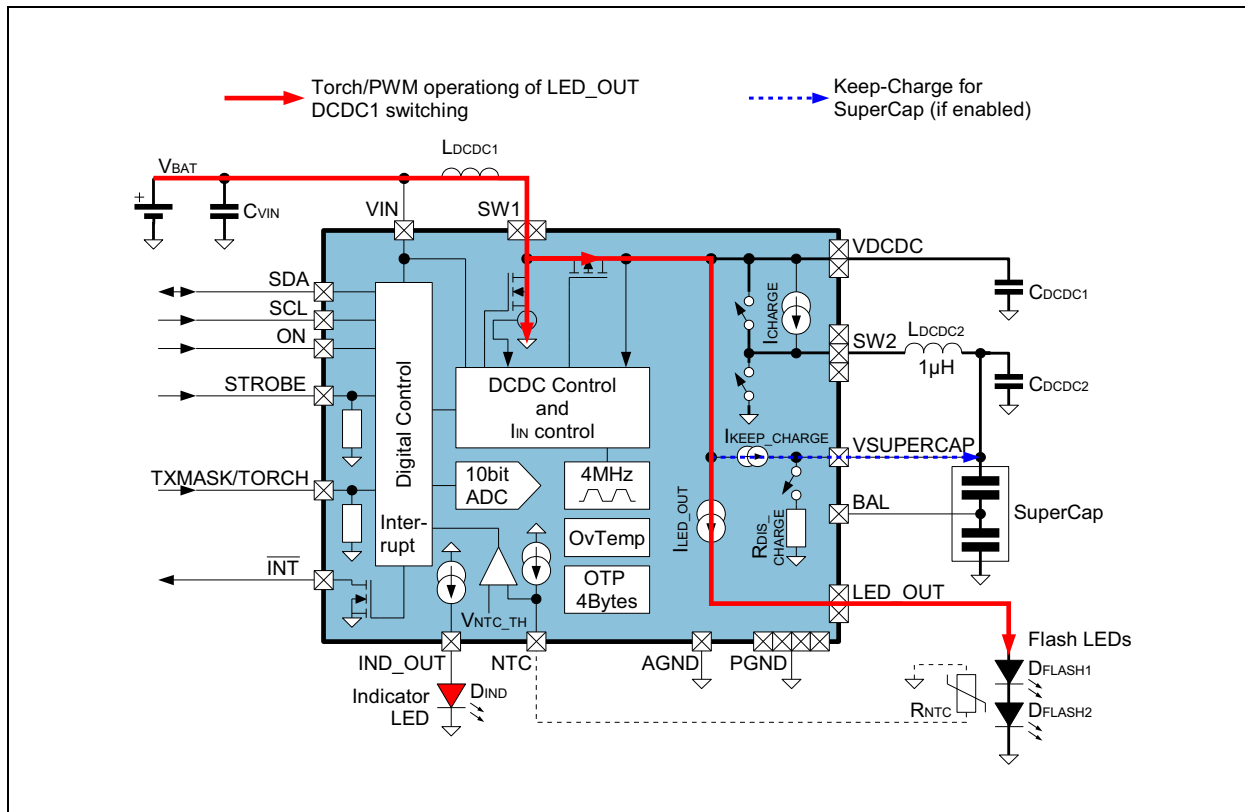

After setting `mode_setting = "Torch" or "PWM Operation"`⁷ the step-up DCDC1 converter is used to generate $-V_{DCDC}$ sufficiently high enough to drive the I_{LED_OUT} current (controlled by `led_current`). If `keep_sc_charged` (page 51)=1, `VSUPERCAP` is charged by the current source `IKEEP_CHARGE` (without exceeding `end_of_charge_voltage`) to maintain the charge on the Supercap during this operating mode.

7. In PWM operation the current source I_{LED_OUT} is PWM modulated with a duty cycle set by `led_out_pwm`.

Flash Operation

Additionally the step up converter DCDC1 (from VIN using L_{DCDC1}), the step up converter DCDC2 (from Supercap using L_{DCDC2}) is used in parallel operating at high efficiency for the flash operation. This allows to reduce the current for each of the DCDC's and therefore the size of the Supercap and/or current required from battery:

Figure AS3630 – 22:
Flash DCDC1 and DCDC2 Parallel Operation to Reduce Current and Size of Supercap

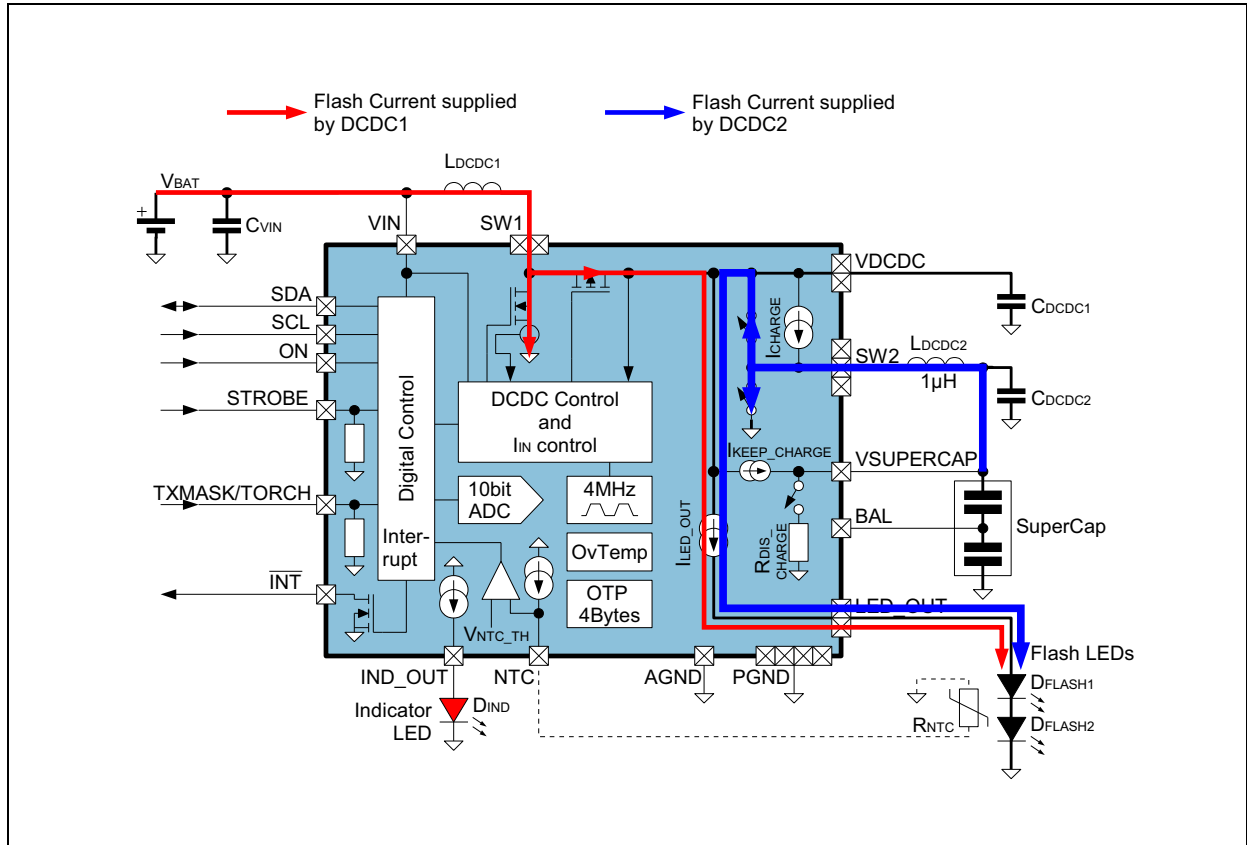

The flash operation is enabled by `mode_setting = "Flash"` and the timeout timer (register `flash_timeout`) defines the maximum flash duration.

Note: If the voltage on VSUPERCAP drops below 2.55V, DCDC2 is automatically stopped (and the flash current is supplied by DCDC1 only).

Once the flash is finished, the AS3630 will automatically select the operating mode according to register `mode_after_flash` (see page 51) shown in Figure 26:

**Figure AS3630 – 23:
Automatically Selected Operating Mode After Flash**

mode_after_flash (see page 51)	mode_setting updated to	Mode selected after flash has been finished
00	000b	Shutdown of AS3630, but leave Supercap at the voltage at the end of the flash
01	001b	Shutdown AS3630 and discharge Supercap
10	010b	Discharge the Supercap to approximately $V_{VIN}-0.3V$ by using <code>RDIS_CHARGE</code> . Afterwards the Supercap is charged to V_{VIN} as shown in Figure 19 and kept at this voltage
11	011b	Supercap is automatically recharged to end_of_charge_voltage

DCDC1 / DCDC2 Operating Principle During Flash

In order to supply the required LED output current during flash operation, DCDC1 (from VIN) and DCDC2 (from Supercap) are used in parallel as shown in [Figure 22](#).

Three different operating modes are used (automatically selected by the AS3630):

1. DCDC1 alone can deliver the full flash current.
 $I_{DCDC1} < \text{coil1_peak}$, $I_{DCDC2} = 0A$
DCDC1 is regulated to deliver the flash LED current alone; no current is used from DCDC2 or the Supercap.
2. DCDC1 and DCDC2 together deliver the flash current.
 I_{DCDC1} hits [coil1_peak](#), $I_{DCDC2} < \text{coil2_peak}$
DCDC1 is operating in peak current limit (controlled by [coil1_peak](#)) and DCDC2 is controlled to deliver the remaining current for the LED. DCDC2 peak current is below the setting [coil2_peak](#).
3. DCDC1 and DCDC2 together cannot deliver the full flash current.
 I_{DCDC1} hits [coil1_peak](#), I_{DCDC2} hits [coil2_peak](#)
In this operating mode both peak current settings together ([coil1_peak](#) and [coil2_peak](#)) are not able to deliver the programmed [led_current](#). Therefore both DCDCs are operating in coil current limit and the LED current is the resulting sum of these two currents. If the register bit [curr_limit_curr_red](#) is set, [led_current](#) is ramped down⁸ until DCDC2 leaves peak current limit and operation continuous at mode 2. (DCDC1 and DCDC2 together deliver the flash current) and [led_current_min](#) is set to the reduced LED current.
4. If the voltage on VSUPERCAP drops below 2.4V, DCDC2 is disabled and the flash current drops to the current supplied by DCDC1 only.

⁸ [fault_current_reduced](#) is set to indicate this condition.

Note: If DCDC1 shall not be used during flash (the whole current has to be delivered by DCDC2 using the Supercap only, no current from VIN) set the registers as follows:

`txmask_torch_mode` = 01b (TXMASK/TORCH is used as TXMask input),

pull TXMASK/TORCH to '1',

`coil1_peak` = 000b.

The AS3630 will then always operate in TXMask mode and switch off DCDC1 (as `coil1_peak` = 000b).

Battery and Flash LED Current Reductions in Flash Mode

Current Reduction by VIN Measurements In Flash Mode

Due to the load of the flash driver and the ESR of the battery (especially critical at low temperatures), the voltage on the battery drops. If the voltage drops below the system reset threshold, the system would reset. To prevent this condition the AS3630 monitors the battery voltage and keeps it above `vin_low_v` as follows:

During flash, if the voltage on VIN drops below the threshold defined by `vin_low_v`, `coil1_peak` current is reduced thus reducing the current from the battery and preventing a system shutdown. Due to the unique regulation scheme (see [DCDC1 / DCDC2 Operating Principle During Flash](#)) more current is automatically used from the Supercap and therefore the flash current is kept constant.

This function can be disabled by setting `vin_low_v` = 000b.

DCDC1 and DCDC2 in Current Limit

See [DCDC1 / DCDC2 Operating Principle During Flash](#) operating mode 3.

TXMASK

The coil L_{DCDC1} current limit is usually defined by `coil1_peak`. If this current is too high to allow parallel operation of another high power load (e.g. the RF power amplifier) without overloading of the battery, the TXMask function can be used.

Set `txmask_torch_mode` = 01b (TXMASK/TORCH is used as TXMask input) and connect the enable line of the other high power load to the AS3630 pin TXMASK/TORCH.

In the event of TXMASK/TORCH=1 during flash, the `coil1_peak` current is instantaneously reduced by `coil1_txmask_curr_red` steps (coding as for `coil1_peak`). If `coil1_peak` minus `coil1_txmask_curr_red` steps would be negative DCDC1 is switched off during TXMask.

Once TXMASK/TORCH=0, the coil peak current is ramped to the previous programmed value of `coil1_peak`.

Continuous LED Current Ramp Down During Flash

If the register `led_current_rampdown` is set, the LED current during flash is continuously ramped down. This has the benefit of using the Supercap energy most efficiently.

Balancing Circuit - Pin BAL

Figure AS3630 – 24:
Balancing Circuit

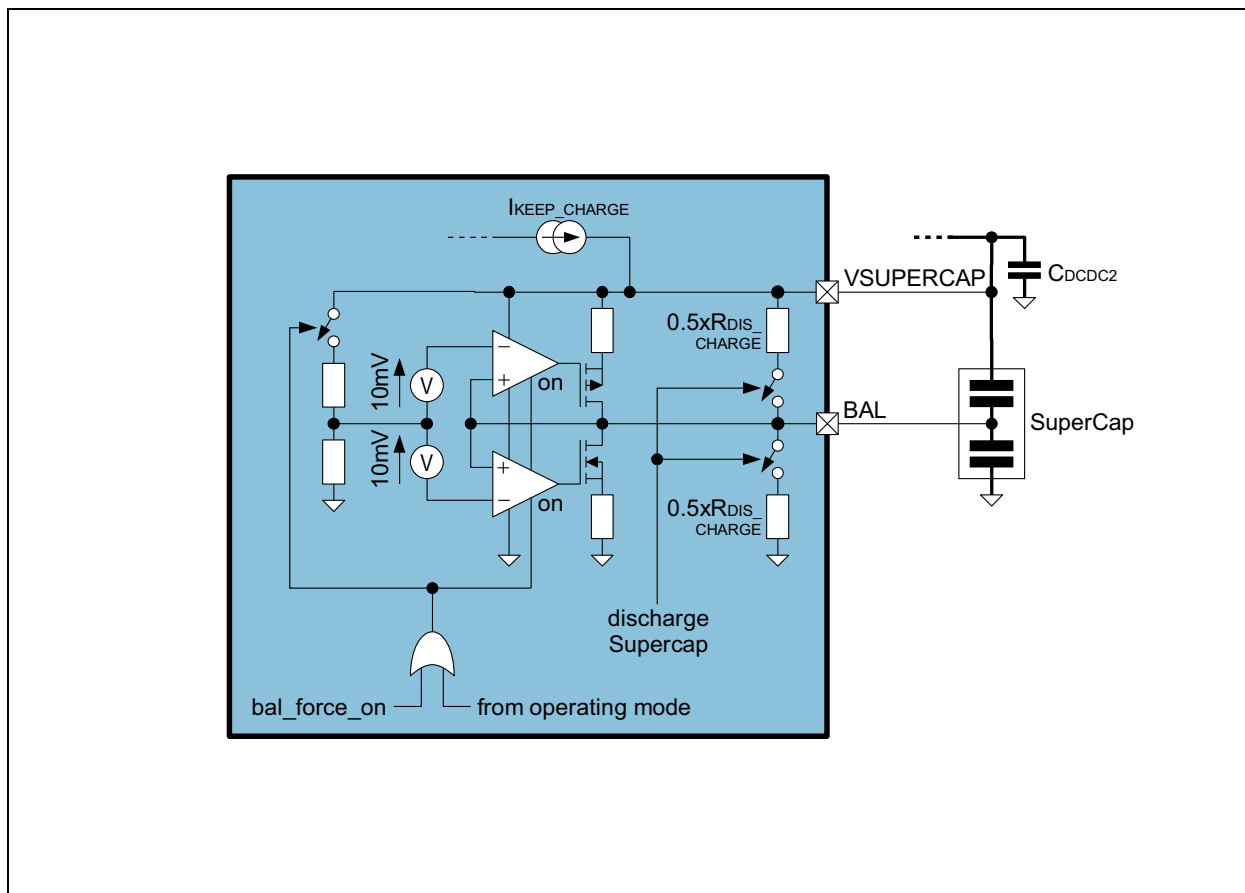

The internal balancing circuit (Figure 24) keeps the voltage between VSUPERCAP-BAL to BAL-GND equal in order to avoid overvoltage on one of the capacitors inside the SuperCap. It is powered from VSUPERCAP, therefore it can operate even if there is no voltage on VIN.

The SuperCap balancing circuit is active in pre-charge, transition, charge, keep charge and discharge. It can be forced on in flash and shutdown if [bal_force_on](#) is set.

Operating Mode and LED Currents

Currents and operating modes are selected according to the following figure:

Figure AS3630 – 25:
Operating Mode and Current Settings

AS3630 Configuration					Operating Mode and Currents		
ON, SCL, SDA	TXMASK/TORCH	STROBE	mode_setting	Condition	Mode	Supercap State	LED_OUT output current
X	No supply on VIN (0V)				Shutdown		
ON=0	X	X	X	VIN supplied	All registers are reset to their default values	Discharging	0
ON=1; I ² C commands are accepted on pins SCLK and SDA	X	X	000b, 001b	txmask_torch_mode not 10	Standby	Keep voltage as is if mode_setting =000b, discharging if mode_setting=001b	0mA
	0	X		txmask_torch_mode =10			
	1	X		txmask_torch_mode =10	External torch mode		led_current ¹ limited to 460mA
	X	X	010b		Pre-charge	Pre-charge Supercap to VIN	0mA
	X	X	011b		Charge	Charge Supercap to end_of_charge_voltage	0mA

AS3630 Configuration				Operating Mode and Currents				
ON, SCL, SDA	TXMASK/TORCH	STROBE	mode_setting	Condition	Mode	Supercap State	LED_OUT output current	
ON=1; I ² C commands are accepted on pins SCLK and SDA	X	X	100b		Torch light mode		led_current ¹ limited to 460mA	
	X	X	101b		PWM operation: Use for indicator with the main flash LED or low current PWM operation ²	If keep_sc_charged =0 keep voltage on Supercap as is; if keep_sc_charged =1 charge Supercap to end_of_charge_voltage with I _{KEEP_CHARGE} - Figure 21 on page 25	led_current ³ limited to 303.9mA PWM modulated by led_out_pwm (1/16...4/16 @ 31.25kHz, 1/32, 3/32 @ 15.625kHz)	
	X	0	110b		Torch operation sync to STROBE - see Figure 32 on page 35	I _{KEEP_CHARGE} - Figure 21 on page 25	0mA	
		1		led_current ¹ limited to 931mA				
	0 or 1 ⁴	X	0- > 1	111b	strobe_on = 0	Flash mode;	Supercap is discharged using DCDC2 to LED_OUT - Figure 22 on page 26 mode selected after flash: see Figure 23 on page 27	led_current for flash duration
					strobe_on = 1 and strobe_type = 0	flash duration defined by flash_timeout		
					strobe_on = 1 and strobe_type = 1	Flash mode; flash duration defined by STROBE input; timeout defined by flash_timeout		

1. If led_current_range=10 will use led_current_range=00.
2. The low current mode is a general purpose PWM mode to drive less current through the LED in average, but keep the actual pulsed current in a range where the light output from the LED is still specified.
3. Will use led_current_range=00.
4. If txmask_torch_mode=01b then the DCDC1 peak coil current is changed depending on input TXMASK/TORCH - see section "TXMASK" on page 28

Current Ranges

Depending on operating mode ([mode_setting](#) (see page 51)) the current settings according to [Figure 26](#) are possible⁹ :

**Figure AS3630 – 26:
LED Current Selections**

led_current_range	External Torch Mode or Torch Mode	PWM Operation	Flash Operation	Torch operation sync to STROBE
00 (10-2500mA range)	Ok, but limited to 460mA	Ok, but limited to 303.9mA	Ok	Ok, but limited to 931mA
01 (10-250mA range)	Ok	Will use 00 range (10-303.9mA)	Ok	Ok
10 (2500-3000mA range)	Will use 00 range (10mA - 460mA)	Will use 00 range (10-303.9mA)	Ok	Will use 00 range (10mA - 931mA)

SOFTSTART / Soft Ramp Down

During startup and ramp down the LED current is smoothly ramped up and ramped down. Additionally the DCDC converter on VIN has a startup mechanism to minimize or eliminate battery input current overshoots.

Indicator Blinking Function

Setting [ind_on=1](#) enabled the indicator current source on pin IND_OUT. If [ind_blink_delay=00](#) or [ind_blink_on_time= 00](#), the current source is constantly enabled with a current defined by [ind_current](#). All other conditions enable the indicator blinking feature as shown in [Figure 27](#) controlled by [ind_blink_on_time](#), [ind_rampup_smooth](#), [ind_rampdown_smooth](#), [ind_blink_delay](#) and [ind_current](#). Smooth current rampup and rampdown is done using PWM modulation.

9. The LED current is limited by hardware to protect the LEDs under any condition.

Figure AS3630 – 27:
Indicator Blinking Function Waveform

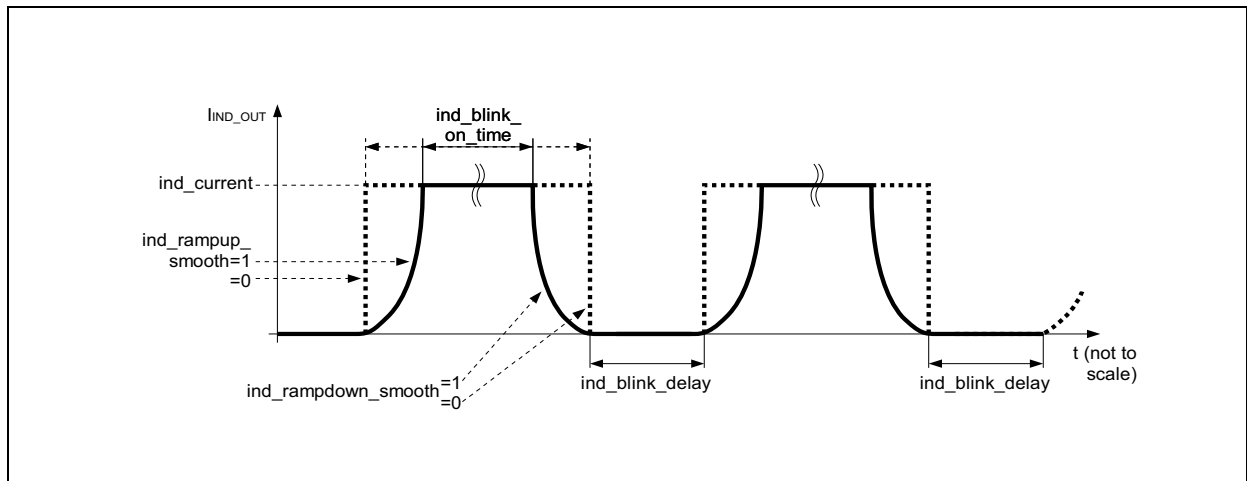

Flash Strobe and Torch Sync to STROBE Timings

The timings are defined as follows:

1. Flash duration defined by register `flash_timeout` and flash is started immediately when this mode is selected by the I²C command (see Figure 28):
 set `strobe_on` = 0, start the flash by setting `mode_setting` = 111b
2. Flash duration defined by register `flash_timeout` and flash started with a rising edge on pin STROBE (see Figure 29):
 set `strobe_on` = 1, `strobe_type` = 0 and setting `mode_setting` = 111b
3. Flash start and timing defined by the pin STROBE; the flash duration is limited by the timeout timer defined by `flash_timeout` (see Figure 30 and Figure 31):
 set `strobe_on` = 1, `strobe_type` = 1 and setting `mode_setting` = 111b
4. Torch operation synchronized to pin STROBE; the current is limited according to Figure 26:
 setting `mode_setting` = 110b

Figure AS3630 – 28:
AS3630 Flash Duration Defined by `flash_timeout` without Using STROBE Input

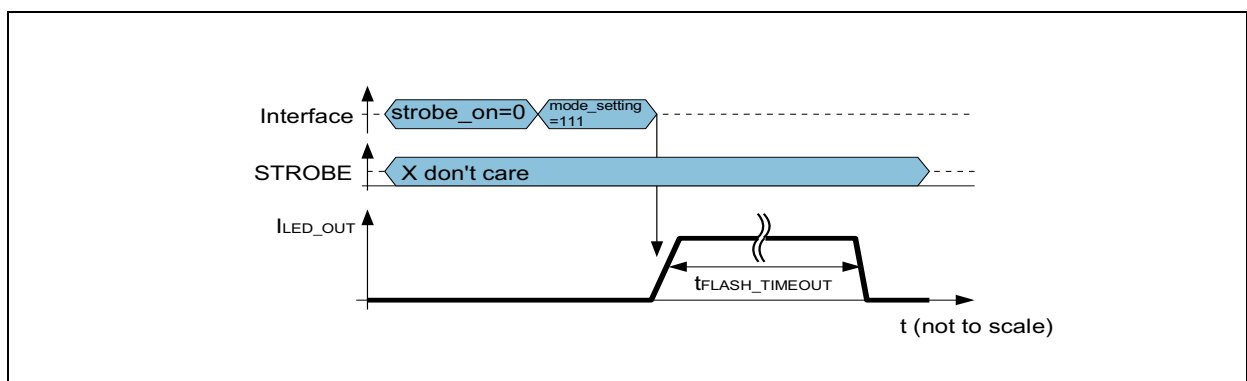

Figure AS3630 – 29:
AS3630 Flash Duration Defined by flash_timeout, Starting Flash with STROBE Rising Edge

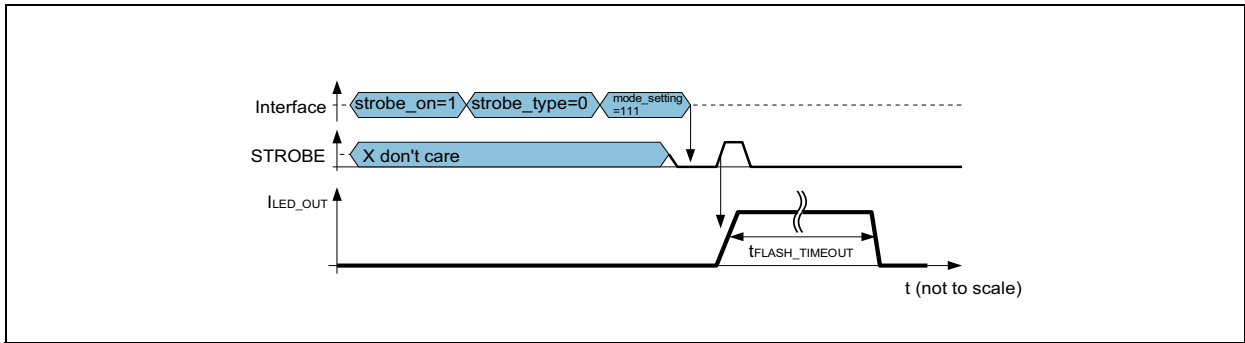

Figure AS3630 – 30:
AS3630 Flash Duration and Start Defined by STROBE, Limited by flash_timeout; Timer Not Expired

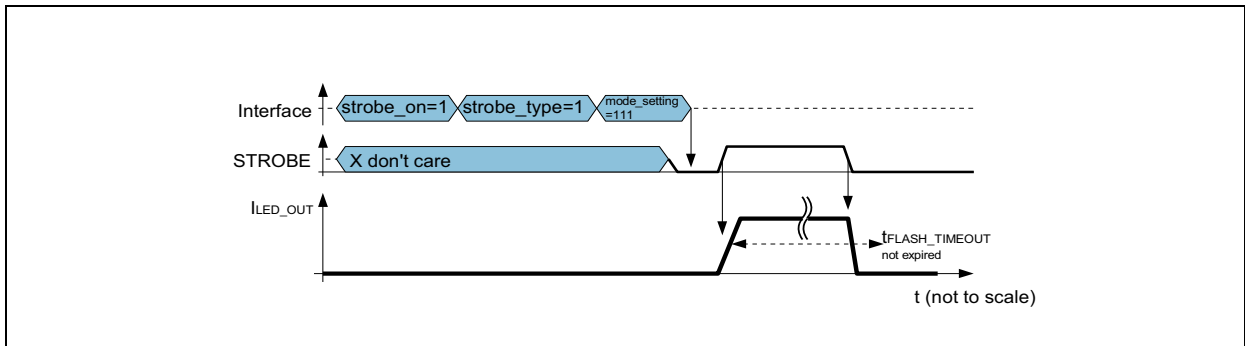

Figure AS3630 – 31:
AS3630 Flash Duration and Start Defined by STROBE, Limited by flash_timeout; Timer Expired

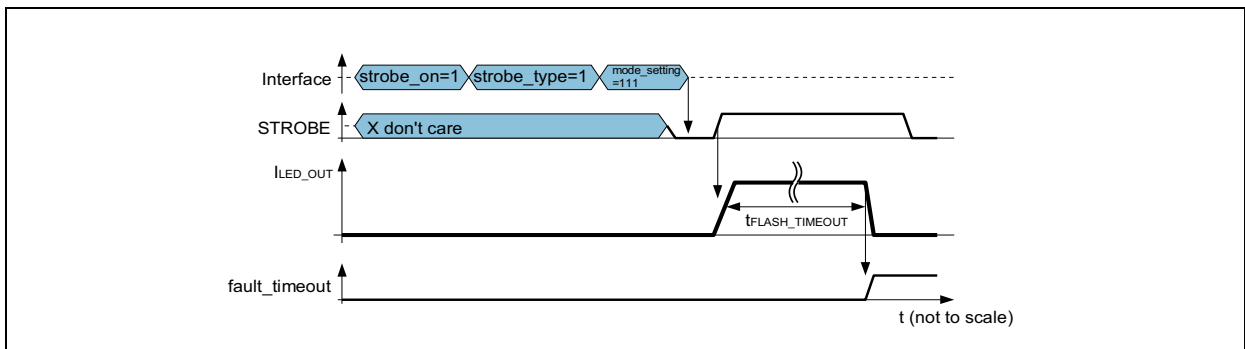
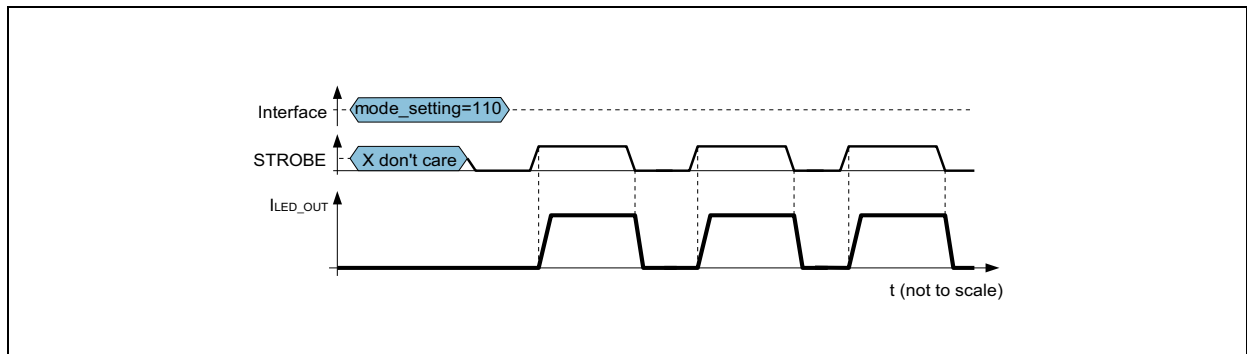

Figure AS3630 – 32:
AS3630 Torch Operation with Duration Synchronized to STROBE Input



Protection, Status, NTC and Fault Detection

Supercap End of Charge Detection - status_eoc

Charging of the Supercap is performed as described in [Figure 20](#). Once charging is finished the register [status_eoc](#) is set.

ADC End of Conversion - status_adc_eoc

Once the ADC conversion is finished, [status_eoc](#) is set - see "ADC" on page 38.

Short/Open LED Protection - fault_led

After the startup of the LED_OUT current source, the voltage on LED_OUT is continuously monitored and compared against V_{LED_SHORT} after the LED current has reached a minimum current depending on [led_current_range](#) (see page 47) - see the figure below:

Figure AS3630 – 33:
Short LED Detection Minimum Current

led_current_range	Short LED Detected Above
00 (10-2500mA range)	>29.4mA
01 (10-250mA range)	>20.58mA
10 (3000mA range)	>23.53mA
11 (4000mA range)	Disabled

If the voltage on LED_OUT stays below V_{LED_SHORT} , a shorted LED is detected.

If the voltage on V_{DCDC} reaches $V_{VOUTMAX}$ and the voltage across the current source between V_{DCDC} and LED_OUT is below V_{FLASH_COMP} an open LED is detected.

If an open or shorted LED is detected, bit `fault_led` is set. The DCDCs and current sinks are disabled and the Supercap is discharged by setting `mode_setting=001b`. In external torch mode, the register `txmask_torch_mode` is reset.

Note: Short/open LED detection is disabled in PWM operating mode (`mode_setting=101b`). The voltage on V_{DCDC} will nevertheless never exceed $V_{VOUTMAX}$.

AS3630 DIE Overtemperature Detected - fault_overtemp

The junction temperature of the AS3630 is continuously monitored. If the temperature exceeds T_{OVTEMP} , the DCDCs are stopped, the current sources are disabled (instantaneous) and the bit `fault_overtemp` is set (but the operating mode `mode_setting` is not changed). The driver is automatically re-enabled once the junction temperature drops below $T_{OVTEMP}-T_{OVTEMPHYST}$.

Note: If an overtemperature is detected in Supercap pre-charge, transition or charge mode, charging is temporarily disabled until the temperature drops, but the register bit `fault_overtemp` is not set.

Timeout Fault - fault_timeout

If the flash is started a timeout timer is started in parallel. If the flash duration defined by the STROBE input (`strobe_on=1` and `strobe_type=1`, see Figure 31) exceeds $t_{FLASH_TIMEOUT}$ (adjustable by register `flash_timeout`), the DCDCs are stopped and the flash current source (on pin LED_OUT) is disabled (ramping down) and `fault_timeout` is set.

If the flash duration is defined by the timeout timer itself (`strobe_on = 0`, see Figure 28), the register `fault_timeout` is not set after the flash has been finished.

AS3630 will automatically select the operating mode according to register `mode_after_flash` shown in Figure 26.

Supercap Short Detected - fault_sc_short

In all operating modes except shutdown (`mode_setting` not 000b or 001b) once $V_{SUPERCAP}$ is above 2.4V both internal capacitors of the Supercap ($V_{SUPERCAP-BAL}$ and BAL-GND) are monitored if they are shorted. If any of them is shorted¹⁰, charging is stopped and the Supercap is discharged by setting `mode_setting=001b` and `fault_sc_short` is set.

10. $V_{SUPERCAP-BAL}$ is compared with typ. 950mV, BAL-GND is compared with typ. 700mV.

NTC - Flash LED Overtemperature Protection - *fault_ntc*

Figure AS3630 – 34:
NTC Internal circuit

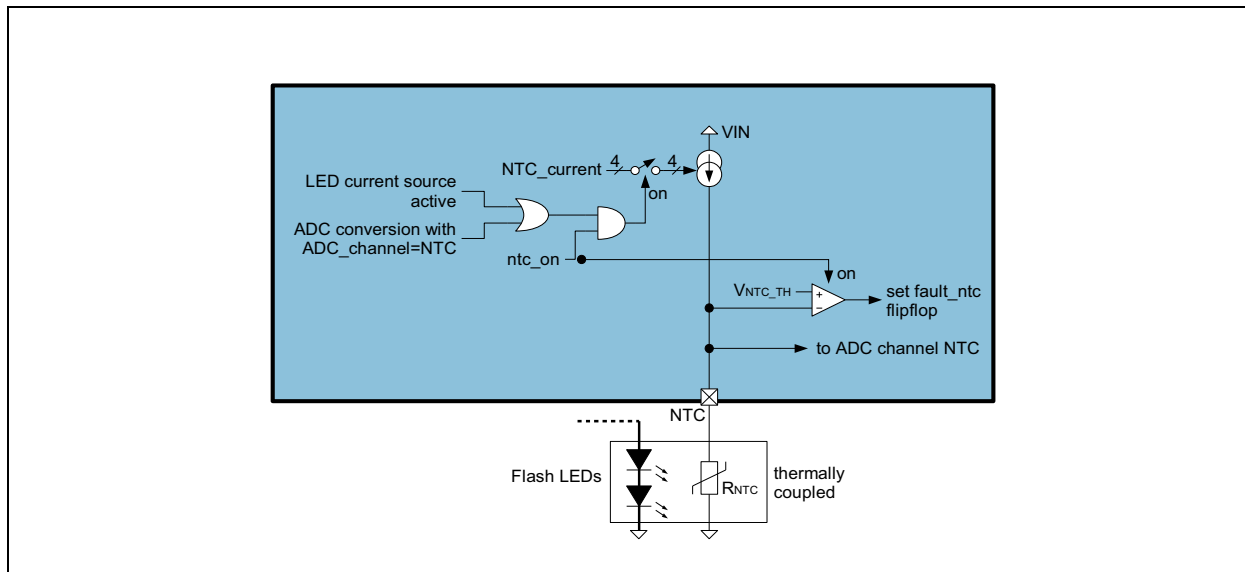

The NTC input can be used to monitor the flash LED temperature if *ntc_on*=1. A internal current source controlled by *NTC_current* sources a current on pin NTC - see Figure 34. If the voltage on pin NTC drops below *VNTC_TH*, *fault_ntc* is set, the DCDCs are stopped and the flash current source (on pin LED_OUT) is disabled (instantaneous) by setting *mode_setting* depending on register *mode_after_flash*. If *mode_after_flash*=001b then *mode_setting*=001b (shutdown and discharge Supercap). All other settings of *mode_after_flash* result in *mode_setting*=000b (shutdown).

As the external NTC cannot measure the LED temperature in real time during a short high current flash pulse (the duration from heating up of the LED until the NTC recognizes a too hot LED is usually too long), it is advisable to measure the LED temperature before the flash pulse (with the ADC and *NTC_current*) and judge how much current can be driven through the LED (to be estimated depending on LED heat sink and is usually specified by the LED manufacturer).

LED Current Reduction Triggered - fault_current_reduced

If during flash the LED current has been reduced (for conditions when this can occur see [DCDC1 / DCDC2 Operating Principle During Flash](#) operating mode 3.), the register bit *fault_current_reduced* is set for indication and *ILED_current_min* is set to the reduced LED current.

The operating mode is not changed and the DCDCs and current source continue operation.

Supply Undervoltage Protection

If the voltage on the pin VIN (=battery voltage) is or falls below V_{UVLO} , the AS3630 is kept in shutdown state and all registers are set to their default state.

Interrupt Output

\overline{INT} is an open drain, active low output. The internal circuit to control this pin is shown in Figure 35.

Figure AS3630 – 35:
Interrupts Processing

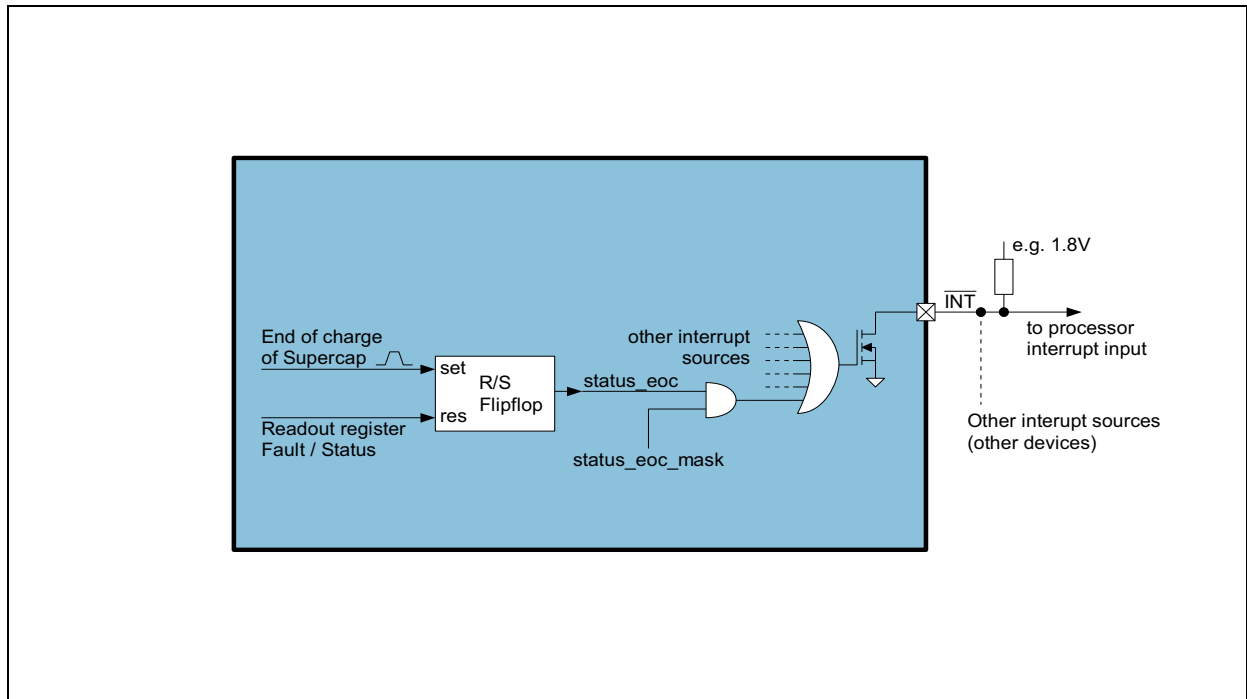

Once an interrupt event occurs (e.g. end of charge of Supercap; detailed description of interrupt events in [“AS3630 Torch Operation with Duration Synchronized to STROBE Input ”](#) on [page 35](#), the interrupt flip flop is set (register `status_eoc`=1). If the interrupt mask is high (register `status_eoc_mask`=1), the output \overline{INT} is pulled to low signaling an interrupt condition. All 8 interrupt flip flops are automatically cleared upon readout of register [Fault / Status](#).

ADC

The ADC is programmed by setting the ADC channel in register [ADC_channel](#) (page 52) and the ADC conversion is performed after setting [ADC_convert](#) (page 52).

The actual timing when the ADC conversion is started / finished is programmed with [ADC_convert](#) as shown in [Figure 36](#):

Figure AS3630 – 36:
ADC Timings

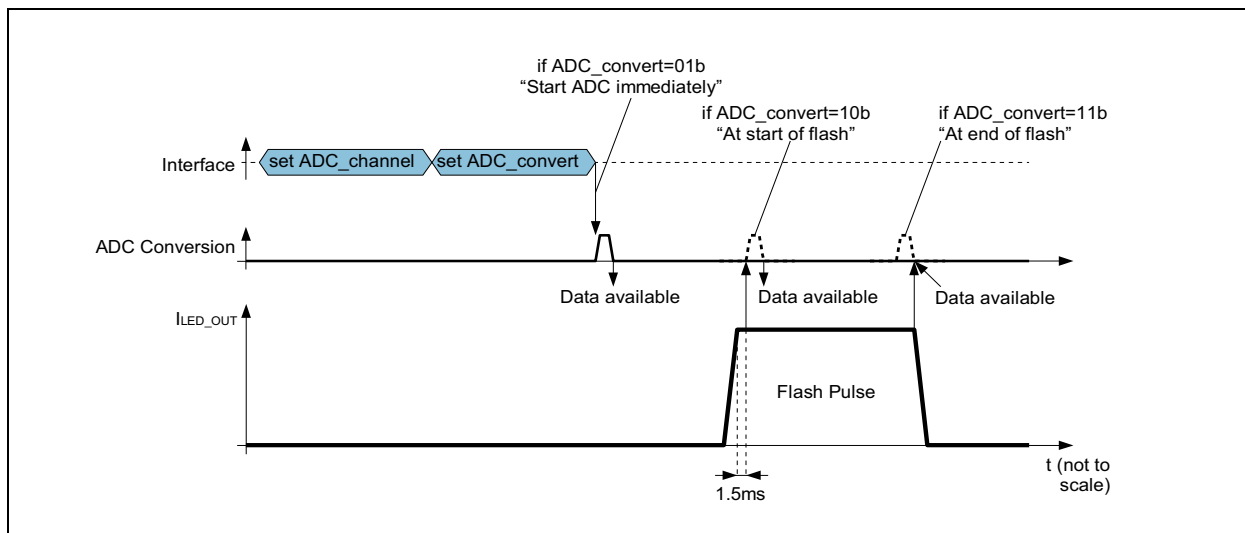

Once the conversion is finished `ADC_convert` returns to 00b, `status_adc_eoc` is set, and the result data is available from register 4 * `ADC_D9-D2 + ADC_D1-D0`.

Note: The ADC input ranges and gains are described in [Figure 6](#) subsection ADC.

I²C Mode Serial Data Bus

The AS3630 supports the I²C bus protocol. A device that sends data onto the bus is defined as a transmitter and a device receiving data as a receiver. The device that controls the message is called a master. The devices that are controlled by the master are referred to as slaves. A master device that generates the serial clock (SCL), controls the bus access, and generates the START and STOP conditions must control the bus. The AS3630 operates as a slave on the I²C bus. Within the bus specifications a standard mode (100kHz maximum clock rate) and a fast mode (400kHz maximum clock rate) are defined. The AS3630 works in both modes. Connections to the bus are made through the open-drain I/O lines SDA and SCL.

The following bus protocol has been defined ([Figure 37](#)):

- Data transfer may be initiated only when the bus is not busy.
- During data transfer, the data line must remain stable whenever the clock line is HIGH. Changes in the data line while the clock line is HIGH are interpreted as control signals.

Accordingly, the following bus conditions have been defined:

Bus Not Busy

Both data and clock lines remain HIGH.

Start Data Transfer

A change in the state of the data line, from HIGH to LOW, while the clock is HIGH, defines a START condition.

Stop Data Transfer

A change in the state of the data line, from LOW to HIGH, while the clock line is HIGH, defines the STOP condition.

Data Valid

The state of the data line represents valid data when, after a START condition, the data line is stable for the duration of the HIGH period of the clock signal. The data on the line must be changed during the LOW period of the clock signal. There is one clock pulse per bit of data.

Each data transfer is initiated with a START condition and terminated with a STOP condition. The number of data bytes transferred between START and STOP conditions are not limited, and are determined by the master device. The information is transferred byte-wise and each receiver acknowledges with a ninth bit.

Acknowledge

Each receiving device, when addressed, is obliged to generate an acknowledge after the reception of each byte. The master device must generate an extra clock pulse that is associated with this acknowledge bit.

A device that acknowledges must pull down the SDA line during the acknowledge clock pulse in such a way that the SDA line is stable LOW during the HIGH period of the acknowledge-related clock pulse. Of course, setup and hold times must be taken into account. A master must signal an end of data to the slave by not generating an acknowledge bit on the last byte that has been clocked out of the slave. In this case, the slave must leave the data line HIGH to enable the master to generate the STOP condition.

Figure AS3630 – 37:
Data Transfer on I²C Serial Bus

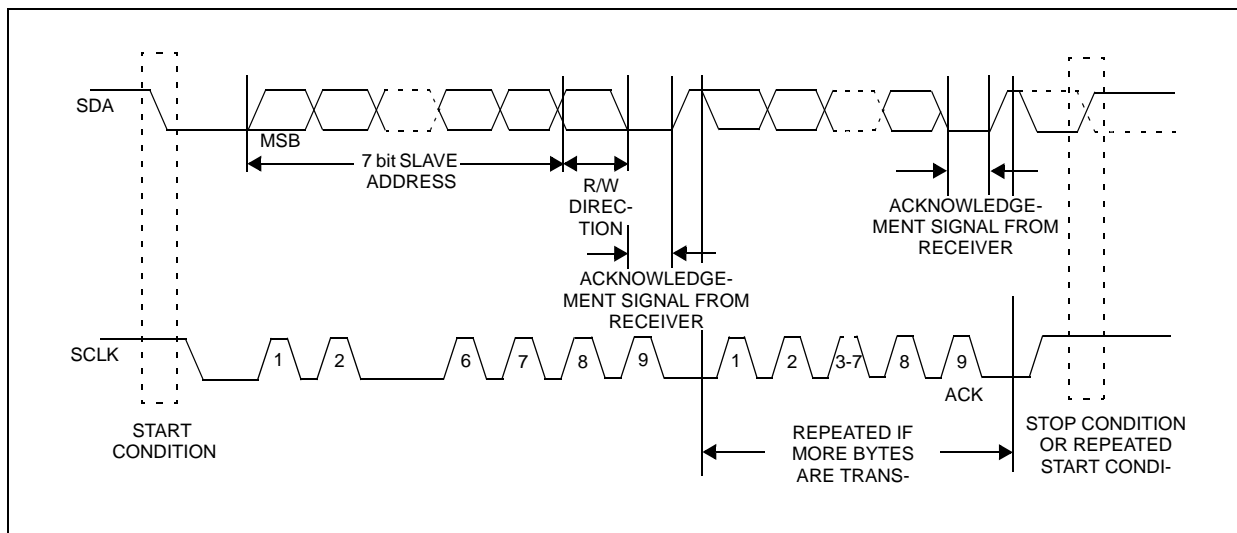

Depending upon the state of the R/W bit, two types of data transfer are possible:

1. **Data transfer from a master transmitter to a slave receiver.** The first byte transmitted by the master is the slave address. Next follows a number of data bytes. The slave returns an acknowledge bit after each received byte. Data is transferred with the most significant bit (MSB) first.
2. **Data transfer from a slave transmitter to a master receiver.** The master transmits the first byte (the slave address). The slave then returns an acknowledge bit, followed by the slave transmitting a number of data bytes. The master returns an acknowledge bit after all received bytes other than the last byte. At the end of the last received byte, a “not acknowledge” is returned. The master device generates all of the serial clock pulses and the START and STOP conditions. A transfer is ended with a STOP condition or with a repeated START condition. Since a repeated START condition is also the beginning of the next serial transfer, the bus is not released. Data is transferred with the most significant bit (MSB) first.

The AS3630 can operate in the following two modes:

1. **Slave Receiver Mode (Write Mode):** Serial data and clock are received through SDA and SCLK. After each byte is received an acknowledge bit is transmitted. START and STOP conditions are recognized as the beginning and end of a serial transfer. Address recognition is performed by hardware after reception of the slave address and direction bit (see Figure 38). The slave address byte is the first byte received after the master generates the START condition. The slave address byte contains the 7-bit AS3630 address, which is shown in Figure 42, followed by the direction bit (R/W), which, for a write, is 0.¹¹ After receiving and decoding the slave address byte the device outputs an acknowledge on the SDA line. After the AS3630

acknowledges the slave address + write bit, the master transmits a register address to the AS3630. This sets the register pointer on the AS3630. The master may then transmit zero or more bytes of data, with the AS3630 acknowledging each byte received. The address pointer will increment after each data byte is transferred. The master generates a STOP condition to terminate the data write.

2. **Slave Transmitter Mode (Read Mode):** The first byte is received and handled as in the slave receiver mode. However, in this mode, the direction bit indicates that the transfer direction is reversed. Serial data is transmitted on SDA by the AS3630 while the serial clock is input on SCLK. START and STOP conditions are recognized as the beginning and end of a serial transfer (Figure 39 and Figure 40). The slave address byte is the first byte received after the master generates a START condition. The slave address byte contains the 7-bit AS3630 address, which is shown in Figure 42, followed by the direction bit (R/W), which, for a read, is 1.¹² After receiving and decoding the slave address byte the device outputs an acknowledge on the SDA line. The AS3630 then begins to transmit data starting with the register address pointed to by the register pointer. If the register pointer is not written to before the initiation of a read mode the first address that is read is the last one stored in the register pointer. The AS3630 must receive a “not acknowledge” to end a read.

Figure AS3630 – 38:
Data Write - Slave Receiver Mode

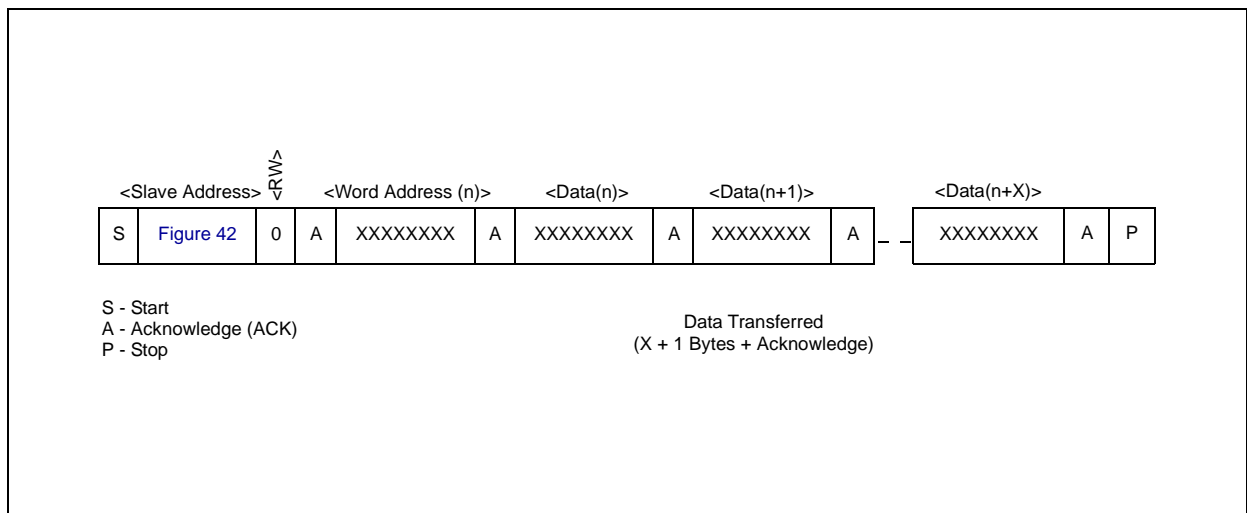

11. The address for writing to the AS3630 is shown in Figure 42

12. The address for read mode from the AS3630 is shown in Figure 42

Figure AS3630 – 39:
Data Read (from Current Pointer Location) - Slave Transmitter Mode

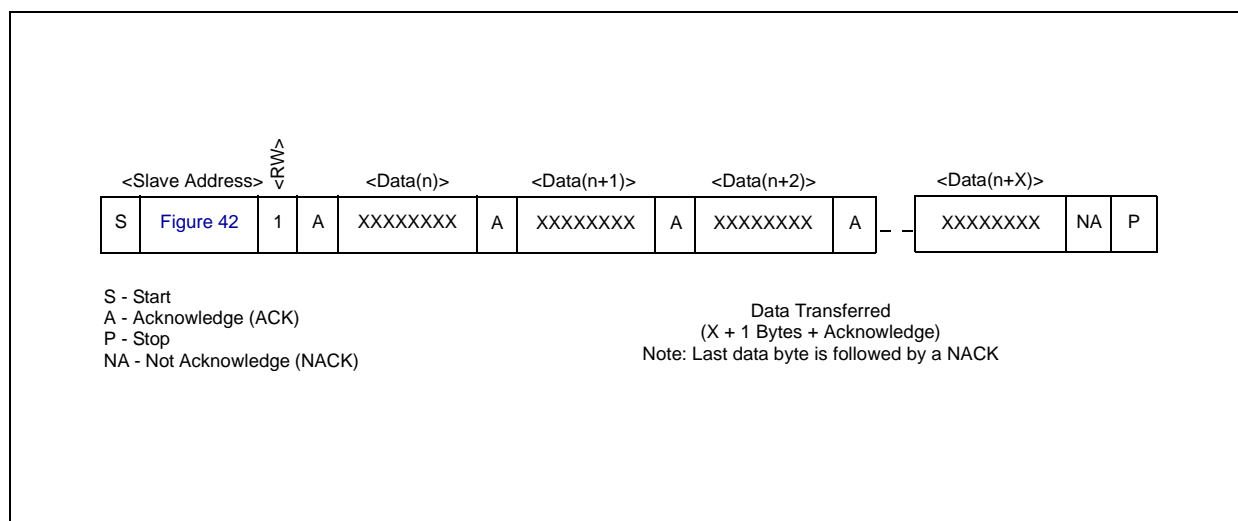
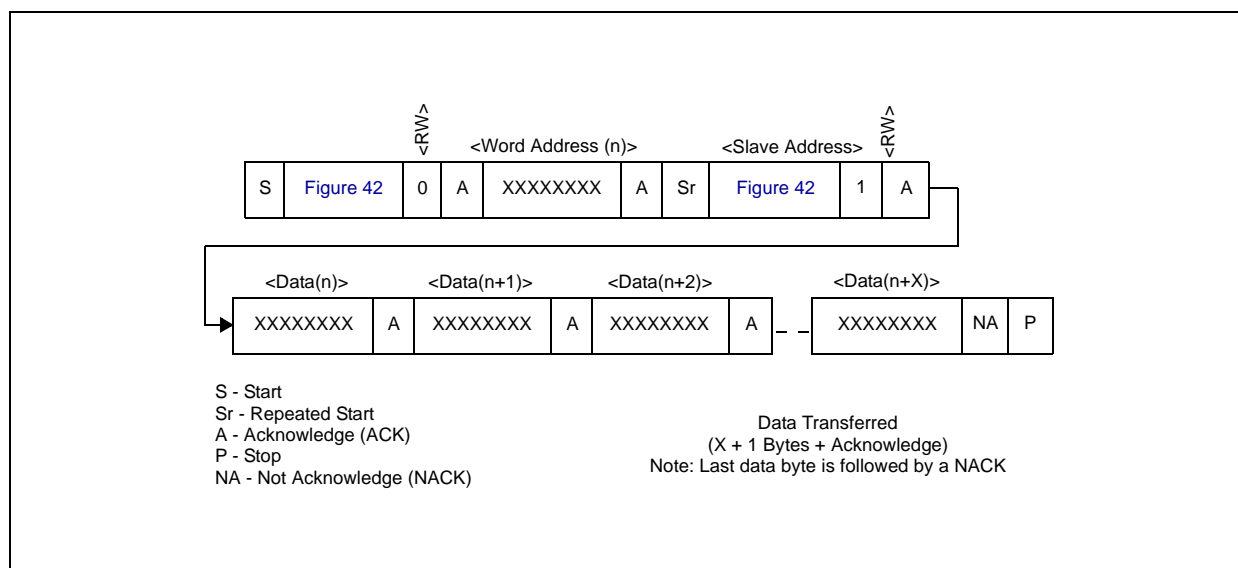

Figure AS3630 – 40:
Data Read (Write Pointer, Then Read) - Slave Receive and Transmit



I²C Address Selection

Note: It is required to read the register **Fixed ID** twice after startup in order for the I²C address selection to identify the I²C address used.

The AS3630 features two I²C slave addresses without having a dedicated address selection pin. The selection of the I²C address is done with the interconnection of AS3630 to the bus lines shown in the figure below. The serial interface logic inside AS3630 is able to distinguish between a direct I²C connection to the master or a second option where data and clock line are crossed. Therefore it is possible to address a maximum of two AS3630 slaves on one I²C bus.

Figure AS3630 – 41:
I²C Address Selection Application Diagram

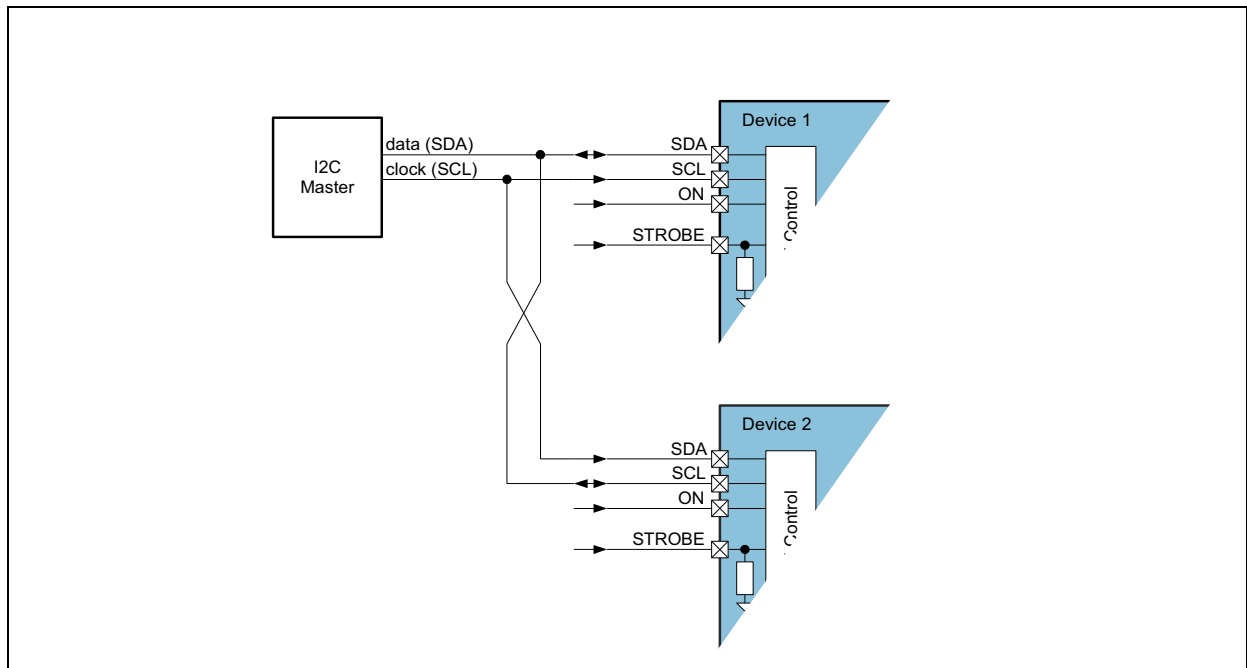

The I²C address use is defined according to the figure below:

Figure AS3630 – 42:
I²C Addresses for AS3630

Device Number Figure 41 on page 44	7 bit I ² C address	8 bit I ² C read address	8 bit I ² C write address
1 (default; SCLK and SDA directly connected)	30h	60h	61h
2 (SCLK and SDA exchanged)	31h	62h	63h

Register Description

Figure AS3630 – 43:
Register Overview

Addr	Name	<D7>	<D6>	<D5>	<D4>	<D3>	<D2>	<D1>	<D0>	
00h	Fixed ID	fixed_id								
	Access	RO								
	Reset Value	17h - fixed id (e.g. to check I ² C communication) Note: It is required to read the register Fixed ID twice after startup in order for the I ² C address selection to identify the I ² C address used.								
01h	Version	reserved					version			
	Access	RO					RO			
	Reset Value	NA					X			
		Don't use by application					Don't use by application			

Addr	Name	<D7>	<D6>	<D5>	<D4>	<D3>	<D2>	<D1>	<D0>		
02h	Current Set LED	led_current									
	Access	RW									
	Reset Value	15h (206mA)									
		LED Current pin LED_OUT; the range of this setting is defined by led_current_range LSB is 9.8mA (2500mA/255) for led_current_range=00b LSB is 980µA (250mA/255) for led_current_range=01b LSB is 11.76mA (3000mA/255) for led_current_range=10b									
			led_current_range								
		led_current		00b		01b		10b		11b	
		00h		0mA		0mA		0mA		0mA	
		01h		9.8mA		Don't use below 10mA (code 0Bh)		Don't use below 2506mA (code D5h)		Don't use below 2996mA (code BFh)	
		02h		19.6mA							
		03h		29.4mA							
								
	D5h		2088mA		209mA		2506mA		3341mA		
		
	FFh		2500mA		250mA		3000mA		4000mA		

Addr	Name	<D7>	<D6>	<D5>	<D4>	<D3>	<D2>	<D1>	<D0>
03h	Boost/TXMask Current	led_current_range		curr_limit_curr_reduced	coil1_txmask_curr_red			txmask_torch_mode	
	Access	RW		RW	RW			RW	
	Reset Value	00b		0b	011b			00b	
	Comment	Range setting for led_current 00...10-2500mA range 01...10-250mA range 10...2500-3000mA range 11...don't use use range "10" only for currents above 2500mA			Reduce L _{DCDC1} current in steps of coil1_peak currents during TXMask (this is a delta value; e.g. -1 means one current step reduction e.g. from 2.5A to 2.0A; -4 means four steps e.g. from 2.5A to 750mA. if the reduction would result in a negative value, DCDC1 is switch off during TXMask event) 000 ... -1 001 ... -2 010 ... -3 011 ... -4 - default value 100 ... -5 101 ... -6 110 ... -7 111 ... -8			Function of TXMASK/TORCH pin 00 ... no effect (default) 01 ... txmask operation mode (applies for flash mode, mode_setting =111b) 10 ... external torch mode (applies for shutdown mode, mode_setting =000b or 001b, max. led_current ≤ 460mA) 11 ... don't use	
				If set, reduce LED current if LDCDC1 and LDCDC2 currents are hit and current source ILED cannot drive the output current. Note: In flash mode LDCDC1 is usually operated in current limit.					

Addr	Name	<D7>	<D6>	<D5>	<D4>	<D3>	<D2>	<D1>	<D0>
04h	Coil and Charge Current	charge_current		coil2_peak			coil1_peak		
	Access	RW		RW			RW		
	Reset Value	01b		010b			100b		
	Comment	Defines charging current of Supercap for pre-charge and 'transition' (to charge); afterwards <code>coil1_peak</code> defines current 00 ... 200mA - low quiescent current mode 01 ... 500mA 10 ... 750mA 11 ... 1000mA	LDCDC2 Coil Peak current limit 000 ... don't use 001 ... don't use 010 ... 2.43A (default) 011 ... 3.14A 100 ... 3.86A 101 ... 4.57A 110 ... 5.29 A 111 ... 6.0A	LDCDC1 Coil Peak current limit 000 ... don't use 001 ... 750mA 010 ... 1A 011 ... 1.5A 100 ... 2A (default) 101 ... 2.5A 110 ... 3A 111 ... 3.5A					

Addr	Name	<D7>	<D6>	<D5>	<D4>	<D3>	<D2>	<D1>	<D0>
06h	Flash Timer	ind_rampup_smooth	ind_rampdown_smooth	flash_timeout					
	Access	RW	RW	RW					
	Reset Value	1	1	0Fh					
		Smooth rampup during indicator blinking if <code>ind_on=1</code> 0... none 1...smooth (380ms)	Smooth rampdown during indicator blinking if <code>ind_on=1</code> 0... none 1...smooth (380ms)	Flash timeout timer - define maximum flash time 4ms steps from 0...15h; 16ms steps from 16h to 63h					
			00h ... 4ms		16h ... 104ms		2Bh ... 440ms		
			01h ... 8ms		17h ... 120ms		2Ch ... 456ms		
			02h ... 12ms		18h ... 136ms		2Dh ... 472ms		
			03h ... 16ms		19h ... 152ms		2Eh ... 488ms		
			04h ... 20ms		1Ah ... 168ms		2Fh ... 504ms		
			05h ... 24ms		1Bh ... 184ms		30h ... 520ms		
			06h ... 28ms		1Ch ... 200ms		31h ... 536ms		
			07h ... 32ms		1Dh ... 216ms		32h ... 552ms		
			08h ... 36ms		1Eh ... 232ms		33h ... 568ms		
			09h ... 40ms		1Fh ... 248ms		34h ... 584ms		
			0Ah ... 44ms		20h ... 264ms		35h ... 600ms		
			0Bh ... 48ms		21h ... 280ms		36h ... 616ms		
			0Ch ... 52ms		22h ... 296ms		37h ... 632ms		
			0Dh ... 56ms		23h ... 312ms		38h ... 648ms		
			0Eh ... 60ms		24h ... 328ms		39h ... 664ms		
			0Fh ... 64ms		25h ... 344ms		3Ah ... 680ms		
			10h ... 68ms		26h ... 360ms		3Bh ... 696ms		
			11h ... 72ms		27h ... 376ms		3Ch ... 712ms		
			12h ... 76ms		28h ... 392ms		3Dh ... 728ms		
			13h ... 80ms		29h ... 408ms		3Eh ... 744ms		
			14h ... 84ms		2Ah ... 424ms		3Fh ... 760ms		
			15h ... 88ms						

Addr	Name	<D7>	<D6>	<D5>	<D4>	<D3>	<D2>	<D1>	<D0>
07h	Control	ind_on	mode_after_flash		keep_sc_charged	ntc_on	mode_setting		
	Access	RW	RW		RW	RW	RW		
	Reset Value	0b	11b		0b	0b	001b		
		indicator current source on IND_OUT 0 ... off 1 ... on, (current set by ind_current)	Set the operating mode after flash (see Figure 23 on page 27): 00... shutdown (leave Supercap charged) 01... shutdown and discharge Supercap 10... pre charge Supercap (to VIN) 11... charge Supercap		If set during PWM,Torch or Charge operation keep Supercap charged with 10mA current	Hardware NTC protection of LED_OUT 0...off 1...on	000 ... shutdown or external torch mode (leave Supercap charged) 001 ... shutdown or external torch mode and discharge Supercap with R _{DIS_CHARGE} - default 010 ... pre charge Supercap (to VIN) 011 ... charge Supercap 100 ... torch operation (wo/ Supercap) - max. led_current ≤ 460mA 101 ... PWM Operation (main LED); max. led_current ≤ 303.9mA; led_current_range is set to 00b 110 ... torch operation sync to STROBE (STROBE=1: LED on; STROBE=0: LED off) max. led_current ≤ 931mA 111 ... Flash Operation		

Addr	Name	<D7>	<D6>	<D5>	<D4>	<D3>	<D2>	<D1>	<D0>
08h	Strobe and ADC control	strobe_on	strobe_type	ADC_convert		ADC_channel			
	Access	RW	RW	RW		RW			
	Reset Value	1b	1b	00b		0h			
		Enable STROBE input	STROBE input is 0 ... edge sensitive 1 ... level sensitive	Control ADC conversion - register is automatically reset to 00 after the conversion is finished		Select ADC channel for conversion 0h ... V _{DCDC} 1h ... LED_OUT 2h ... Tjunc (DIE Junction temperature) 3h ... VSUPERCAP 4h ... don't use 5h ... BAL 6h ... VIN 7h ... NTC 8h ... IND_OUT 9h ... don't use Ah ... PGND. Bh ... don't use Ch ... STROBE Dh ... $\overline{\text{INT}}$ Eh ... ON Fh ... don't use			
			00 ... ADC shutdown (no conversion performed or end of conversion) 01 ... start ADC conversion immediately 10 ... do ADC conversion 1.5ms after current rampup (beginning of flash) 11 ... do ADC conversion just before current rampdown (at end of flash; flash duration is extended by 100µs)						

Addr	Name	<D7>	<D6>	<D5>	<D4>	<D3>	<D2>	<D1>	<D0>
09h	Fault / Status	status_eoc	status_adc_eoc	fault_led	fault_overnmp	fault_timeout	fault_sc_short	fault_ntc	fault_current_reduced
	Access	SS_RC ¹	SS_RC	SS_RC	SS_RC	SS_RC	SS_RC	SS_RC	SS_RC
	Reset Value	0b	0b	0b	0b	0b	0b	0b	0b
		End Of Supercap Charge (see page 35)	ADC end of conversion reached (see page 35)	Shorted or open LED (LED_OUT) detected (see page 35)	Overtemperature (Tjunction) triggered (see page 36)	Timeout has triggered (see page 36)	Detect a shorted Supercap (BAL-GND) or (VSUPERCAP-BAL) during charging (see page 36)	LED Overtemperature detection hit (monitored by NTC) (see page 36)	LED Current has been reduced and register
led_current_min reports min. led current during flash cycle (see page 37)									
0Ah	Interrupt Mask	status_eoc_mask	status_adc_eoc_mask	fault_led_mask	fault_overnmp_mask	fault_timeout_mask	fault_sc_short_mask	fault_ntc_mask	fault_current_reduced_mask
	Access	RW	RW	RW	RW	RW	RW	RW	RW
	Reset Value	0b	0b	0b	0b	0b	0b	0b	0b
		If set, end of Supercap charge triggers $\overline{\text{INT}}$	If set ADC end of conversion triggers $\overline{\text{INT}}$	If set, a shorted or open LED (LED_OUT) triggers $\overline{\text{INT}}$	If set, overtemperature (Tjunction) triggers $\overline{\text{INT}}$	If set timeout triggers $\overline{\text{INT}}$	If set fault_sc_short triggers $\overline{\text{INT}}$	If set fault_ntc triggers $\overline{\text{INT}}$	If set fault_current_reduced triggers $\overline{\text{INT}}$

Addr	Name	<D7>	<D6>	<D5>	<D4>	<D3>	<D2>	<D1>	<D0>
0Bh	PWM and Indicator	ind_blink_delay		ind_current			led_out_pwm		
	Access	RW		RW			RW		
	Reset Value	01b		000b			000b		
		Control indicator blinking function delay between blinks if ind_on=1 00 ... continuously on (no blinking) 01 ... 512ms 10 ... 1024ms 11 ... 2048ms		IND_OUT current setting if ind_on=1 000 ... 1mA 001 ... 2mA 010 ... 3mA 011 ... 4mA 100 ... 5mA 101 ... 6mA 110 ... 7mA 111 ... 8mA				PWM modulate LED_OUT current if mode_setting =PWM operation; automatically uses led_current_range =00 (10mA...2500mA) but limits current to 303.9mA (codes 00h...1Fh for led_current) 000 1/32 PWM at 15.625kHz- subharmonic oscillation are possible - not recommended to use 001 don't use - use 1/16 instead 010 3/32 PWM at 15.625kHz 011 don't use - use 2/16 instead 100 1/16 PWM at 31.25kHz 101 2/16 PWM at 31.25kHz 110 3/16 PWM at 31.25kHz 111 4/16 PWM at 31.25kHz	
0Ch	Minimum LED Current	led_current_min							
	Access	RO							
	Reset Value	00h							
		At the beginning of a flash pulse, led_current_min is set to led_current then it is reduced upon following condition: (coil1_peak hit and coil2_peak hit and curr_limit_curr_red =1); led_current_min has the same coding used as led_current (the current reduction happens in steps as the coding of led_current is done)							

Addr	Name	<D7>	<D6>	<D5>	<D4>	<D3>	<D2>	<D1>	<D0>
0Dh	ADC MSB	ADC_D9-D2							
	Access	RO							
	Reset Value	NA							
		ADC MSB results bit 9 to bit 2							
0Eh	ADC LSB	led_current_rampdown							ADC_D1-D0
	Access	RW							RO
	Reset Value	00							NA
		Automatically ramp-down of LED current register <code>led_current</code> during flash 00 ... no ramp-down 01 ...1LSB every 100µs 10 ...1LSB every 200µs 11 ...1LSB every 500µs							ADC LSB results bit 1 to bit 0

Addr	Name	<D7>	<D6>	<D5>	<D4>	<D3>	<D2>	<D1>	<D0>
0Fh	NTC	test6	skip_enable	ind_blink_on_time		NTC_current			
	Access	R/W	RW	RW		RW			
	Reset Value	0	1	10		8h			
		Test bit - don't use	Allow pulse-skip operation or force 4MHz operation 0...4MHz operation 1...pulse-skip	Control indicator blinking on-time if <code>ind_on=1</code> (excluding rampup/down) 00 ... 0ms (immediate ramp-down after ramp-up) 01 ... 128ms 10 ... 256ms - default 11 ... 512ms	Current through the NTC when overtemperature protection of the LEDs (LED_OUT) is monitored 0h ... off; use for an external drive of NTC 1h ... 40µA 2h ... 80µA 3h ... 120µA 4h ... 160µA 5h ... 200µA 6h ... 240µA 7h ... 280µA 8h ... 320µA - default 9h ... 360µA Ah ... 400µA Bh ... 440µA Ch ... 480µA Dh ... 520µA Eh ... 560µA Fh ... 600µA				
10h	OTP1	OTP_data1							
	Access	RO							
	Reset Value	NA							
		Data of OTP							

Addr	Name	<D7>	<D6>	<D5>	<D4>	<D3>	<D2>	<D1>	<D0>
11h	OTP2	OTP_data2							
	Access	RO							
	Reset Value	NA							
		Data of OTP							
12h	OTP3	OTP_data3							
	Access	RO							
	Reset Value	NA							
		Data of OTP							
13h	OTP4	OTP_lock	OTP_data4						
	Access	RO	RO						
	Reset Value	NA	NA						
			Data of OTP						
		0 ... OTP is program-able (unlocked) 1... OTP is locked and no further programming of OTP is possible							

1. SS_RC = automatically cleared upon readout

Register Map

Figure AS3630 – 44:
Register Map

Addr	Name	Default	<D7>	<D6>	<D5>	<D4>	<D3>	<D2>	<D1>	<D0>	
00h	Fixed ID	17h	fixed_id								
01h	Version	XXh	reserved					version			
02h	Current Set LED	15h	led_current								
03h	Boost/TXMask Current	0Ch	led_current_range		curr_limit_curr_red	coil1_txmask_curr_red			txmask_torch_mode		
04h	Coil and Charge Current	54h	charge_current		coil2_peak			coil1_peak			
05h	Charge / Low Voltage	2Dh	bal_force_on	end_of_charge_voltage				vin_low_v			
06h	Flash Timer	CFh	ind_rampup_smooth	ind_rampdown_smooth	flash_timeout						
07h	Control	61h	ind_on	mode_after_flash		keep_sc_charged	ntc_on	mode_setting			
08h	Strobe and ADC control	C0h	strobe_on	strobe_type	ADC_convert		ADC_channel				
09h	Fault / Status ¹	00h	status_eoc	status_adc_eoc	fault_led	fault_overtemp	fault_timeout	fault_sc_short	fault_ntc	fault_current_reduced	

Addr	Name	Default	<D7>	<D6>	<D5>	<D4>	<D3>	<D2>	<D1>	<D0>
0Ah	Interrupt Mask	00h	status_eoc_mask	status_adc_eoc_mask	fault_led_mask	fault_overtemp_mask	fault_timeout_mask	fault_sc_short_mask	fault_ntc_mask	fault_current_reduced_mask
0Bh	PWM and Indicator	40h	ind_blink_delay		ind_current			led_out_pwm		
0Ch	Minimum LED Current	NA	led_current_min							
0Dh	ADC MSB	NA	ADC_D9-D2							
0Eh	ADC LSB	0Xh	led_current_rampdown	0	0	0	0	ADC_D1-D0		
0Fh	NTC	68h	test6	skip_enable	ind_blink_on_time		NTC_current			
10h	OTP1	NA	OTP_data1 ²							
11h	OTP2	NA	OTP_data2							
12h	OTP3	NA	OTP_data3							
13h	OTP4	NA	OTP_lock	OTP_data4						

Read-Only Register
R/W Register

if writing to read-only register is required, write '0' to read-only positions (e.g. ADC LSB)

1. The register **Fault / Status** is a read only register, which is automatically cleared after readout. Therefore only a single I²C access is required to poll the status of the AS3630.
2. If OTP data are fused in-circuit, expect a small yield loss.

Application Information

External Components

Supercap

The Supercap performance is critical for the performance of AS3630. As the Supercap is affected by aging, the flash performance has to be checked at end of life conditions.

Figure AS3630 – 45:
Recommended Supercap's

Part Number	C	ESR	Rated Voltage Peak	Rated ¹ Voltage	Matching ²	Temp Range ³	Size	Manufacturer
DME2Z5R5K43 4M3BT	430mF ±20%	50mΩ	5.5V	4.2V	<5%	-30°C... +70°C	20.5x18.5 x3.2mm	Murata www.murata.com
DME2U5R5L35 4M3BT	350mF ±20%	60mΩ	5.5V	4.2V	<5%	-30°C... +70°C	20.5x18.5 x3.0mm	
DMF3R5R5L35 4M3DTA0	350mF ±20%	60mΩ	5.5V	4.2V	<5%	-30°C... +70°C	21.0x14.0 x2.5mm	
EDLC082644-3 31-2F-11	330mF	80mΩ	5.5V	3.2V		-20°C... +70°C	26x44 x0.8mm	TDK www.tdk-component.com

1. Can be applied constantly

2. Difference of Capacitance of top capacitor (between VSUPERCAP/BAL) to capacitance of bottom capacitor (between BAL/GND).

3. Operating temperature range

LEDs

The LED with its optics and its performance are a key element in a Supercap LED flash. Therefore use 2 high power LEDs with lowest forward voltage.

**Figure AS3630 – 46:
Recommended LEDs**

Part Number	V _f @ 1A	Brightness @ 1A	I _{LED} @ 25°C	I _{LED peak} @ 25°C	Size	Manufacturer
CUW CFUP	3.5V (max. 4.2V)	250-355lm	30mA-120 0mA	2500mA, t≤ 10ms, duty=0.005	2x1.64x0.6 3mm, max H 0.74mm	Osram-OS www.osram-os.com
CL-778					2.24x1.84x 0.75mm	Citizen Electronics ce.citizen.co.jp/lighting_led/en/index.html
LXCL-LW07				3000mA		Lumileds www.philipslumileds.com

Input Capacitor C_{VIN}

Low ESR input capacitors reduce input switching noise and reduce the peak current drawn from the battery. Ceramic capacitors are required for input decoupling and should be located as close to the device as is practical.

**Figure AS3630 – 47:
Recommended Input Capacitor**

Part Number	C	TC Code	Related Voltage	Size	Manufacturer
GRM188R60J106ME47	10μ >3μF@4.5V >2μF@5.25V	X5R	6V3	0603	Murata www.murata.com
LMK107BBJ106MA	10μ >3μF@4.5V	X5R	6V3	0603	Taiyo Yuden www.t-yuden.com

If a different input capacitor is chosen, ensure similar ESR value and at least 3μF capacitance at the maximum input supply voltage. Larger capacitor values (C) may be used without limitations.

Optionally add a smaller capacitor in parallel to the input pin VIN (e.g. Murata GRM155R61C104, >50nF @ 3V, 0402 size).

Output Capacitor C_{DCDC1} , C_{DCDC2}

Low ESR capacitors should be used to minimize V_{DCDC} ripple and therefore current ripple on the LED. Multi-layer ceramic capacitors are recommended since they have extremely low ESR and are available in small footprints. The capacitor should be located as close to the device as is practical.

X5R dielectric material is recommended due to their ability to maintain capacitance over wide voltage and temperature range.

Figure AS3630 – 48:
Recommended DCDCs Capacitor

Part Number	C	TC Code	Related Voltage	Size	Manufacturer
GRM219R61A106ME47	10 μ F \pm 20% >4.8 μ F@5V	X5R	10V	0805 (2.0x1.25x0.85mm max 1mm height)	Murata www.murata.com
GRM219R61A106ME44 ¹	10 μ F \pm 10% >4.05 μ F@5V				
2 x C2012X5R1A106M ²	10 μ F \pm 20%	X5R	10V	2x0805 (2.0x1.25x0.85mm max 0.95mm height)	TDK www.tdk.com

1. If $T_{AMB} < 70^{\circ}\text{C}$ or higher output voltage ripple can be tolerated.

2. Use 2 in parallel for C_{DCDC1} and C_{DCDC2} to reach the required output capacitor of >4.2 μ F capacitance at 5V.

If a different output capacitor is chosen, ensure similar ESR values and at least 4.2 μ F capacitance at 5V output voltage and for C_{DCDC1} 10V voltage rating, C_{DCDC2} 6.3V voltage rating.

Inductor L_{DCDC1}

L_{DCDC1} is used for charging of the Supercap, operate the LED in torch and PWM operation and in parallel to L_{DCDC2} to power the LED during flash. Due to the different durations of the operation modes, different peak current limits apply (see Figure 49).

The fast switching frequency (4MHz) of the AS3649 allows for the use of small SMDs for the external inductor. The saturation current $I_{SATURATION}$ should be chosen to be above the maximum value of I_{LDCDC1} ¹³. The inductor should have very low DC resistance (DCR) to reduce the I^2R power losses - high DCR values will reduce efficiency.

13. Can be adjusted in I²C mode with register coil1_peak

**Figure AS3630 – 49:
Recommended Inductor**

Part Number	L	DCR	max. coil1_peak setting for		Size	Manufacturer
			Other modes	Flash		
LQM32PN1R0MG0	1.0μH >0.6μH @ 3.0A	60mΩ	2.0A	3.0A ¹	3.2x2.5x0.9mm max 1.0mm height	Murata www.murata.com
SPM3012T-1R0M	1.0μH ±20%	57mΩ ±10%	2.5A	3.0A (3.5A ²)	3.2x3x1.2 mm height is max	TDK www.tdk.com
CIG32W1R0MNE	1.0μH >0.7μH @ 2.7A >0.6μH @ 3.0A	60mΩ ±25%	2.0A	3.0A	3.2x2.5mm max 1.0mm height	Samsung Electro-Mechancs www.sem.samsung.co.kr
CKP3225N1R0M	1.0μH >0.6μH @ 3.0A	<60mΩ	1.0A	3.0A ³	3.2x2.5x0.9mm max 1.0mm height	Taiyo Yuden www.t-yuden.com
MAMK2520T1R0M	1.0μH >0.6μH @ 2.75A	45mΩ	2.5A	2.5A	2.5x2.0x1.2mm height is max	

- Flash pattern: 200ms/3A, 200ms pause, 200ms/3A, 2s then repeat again (no limit on the number of total cycles)
Alternative pattern with 1000ms/1.6A, 200ms pause, 200ms/3A, 200ms pause, 200ms/3A, 2s then repeat again. (no limit on the number of total cycles)
- Check with coil supplier
- Check with coil supplier for worst case flash pattern.

If a different inductor is chosen, ensure similar DCR values and at least 0.6μH inductance at ILDCD1 set by `coil1_peak`.

Inductor L_{DCDC2}

L_{DCDC2} is used in parallel to L_{DCDC1} to power the LED during flash. The whole current from the Supercap flows through L_{DCDC2} therefore a high power inductor is required.

The fast switching frequency (4MHz) of the AS3649 allows for the use of small SMDs for the external inductor. The saturation current ISATURATION should be chosen to be above the maximum value of ILDCD2¹⁴. The inductor should have very low DC resistance (DCR) to reduce the I²R power losses - high DCR values will reduce efficiency

14. Can be adjusted in I²C mode with register coil2_peak

**Figure AS3630 – 50:
Recommended Inductor**

Part Number	L	DCR	max. coil2_peak setting	Size	Manufacturer
MPI4040R2-1R0-R	1.0μH >0.6μH @ 6.0A	25mΩ	6.0A ¹ (max. value)	4.06x4.45x1.5mm height is max	Coiltronics (Cooper Bussmann) www.cooperbussmann.com
MPI4040R1-1R0-R	1.0μH >0.6μH @ 6.0A	40mΩ	check with coiltronics	4.06x4.45x1.2mm height is max	
XAL4020-102ME_	1.0μH >0.6μH @ 6.0A	13.25mΩ	6.0A (max. value)	4x4x2mm max 2.1mm height	Coilcraft www.coilcraft.com
XFL4020-102ME_	1.0μH >0.6μH @ 5.29A	14.4mΩ	5.29A	4x4x2mm max 2.1mm height	
SPM4012T-1R0M	1.0μH ± 20%	38mΩ	4.57A	4.4x4.1x1.2 mm height is max	TDK www.tdk.com
SPM3012T-1R0M	1.0μH ± 20%	57mΩ ±10%	3.0A (3.5A ²)	3.2x3x1.2 mm height is max	
LQM32PN1R0MG0	1.0μH >0.6μH @ 3.0A	60mΩ	3.0A ³	3.2x2.5x0.9 mm max 1.0mm height	Murata www.murata.com
CIG32W1R0MNE	1.0μH >0.7μH @ 2.7A >0.6μH @ 3.0A	60mΩ ±25%	3.0A	3.2x2.5mm max 1.0mm height	Samsung Electro-Mechanics www.sem.samsung.co.kr
CKP3225N1R0M	1.0μH >0.6μH @ 3.0A	<60mΩ	3.0A ⁴	3.2x2.5x0.9 mm max 1.0mm height	Taiyo Yuden www.t-yuden.com

- Flash profile and max. TAMB to be checked with coil manufacturer.
- Check with coil supplier
- Flash pattern: 200ms/3A, 200ms pause, 200ms/3A, 2s then repeat again (no limit on the number of total cycles)
Alternative pattern with 1000ms/1.6A, 200ms pause, 200ms/3A, 200ms pause, 200ms/3A, 2s then repeat again. (no limit on the number of total cycles)
- Check with coil supplier for worst case flash pattern.

If a different inductor is chosen, ensure similar DCR values and at least 0.6μH inductance at ILDCD2 set by `coil2_peak`.

Thermistor (NTC)

The NTC is used to protect the LED against overheating (hardware protection inside the AS3649, which works without any software - see “[NTC - Flash LED Overtemperature Protection - fault_ntc](#)” on page 37.

The thermistor has to be thermally coupled to the LED (and therefore as close as possible to the LED) and it shall not share the same ground connection as the LED return ground (if they share the same ground connection the high current through the LED will offset the measurement of the NTC).

Figure AS3630 – 51:
Recommended Thermistors

Part Number	Resistance @ 25°C	B-constant 25/50°C	Size	Manufacturer
NCP02WF104F05RH	100kΩ ±1%	4250k ±1%	01005 (inch)	Murata www.murata.com
NCP02XH103F05RH	10kΩ ±1%	3380k ±1%	01005 (inch)	
NCP03WL224E05RL	220kΩ ± 3%	4485K ± 1%	0201 (inch)	
NCP03WL104E05RL	100kΩ ± 3%	4485K ± 1%		
NCP15WF104F03RC	100kΩ		0402 (inch)	
NCP15WL683J03RC	68kΩ			
NTCG104QH224HT	220kΩ ± 3%	4750k ± 3%	1.0x0.5mm	TDK www.tdk.com
NTCG104EF104FT	100kΩ ± 1%	4250k ± 1%		
NTCG104LH683JT	68kΩ ± 5%	4550k ± 3%		
NTCG104BF683JT		4085k ± 1%		

It is recommended to use 220kΩ resistance for a detection threshold of 125°C, 100kΩ for 110°C and 68kΩ for 80°C LED temperature detection threshold.

PCB Layout Guideline

The high speed operation requires proper layout for optimum performance. Route the power traces first and try to minimize the area and wire length.

At the pin GND a single via (or more vias, which are closely combined) connects to the common ground plane. This via(s) will isolate the DCDC high frequency currents from the common ground - see the 'ground via' in [Figure 52](#).

Figure AS3630 – 52:
Layout Recommendation Using a 3225 Coil for L_{DCDC1} and L_{DCDC2}

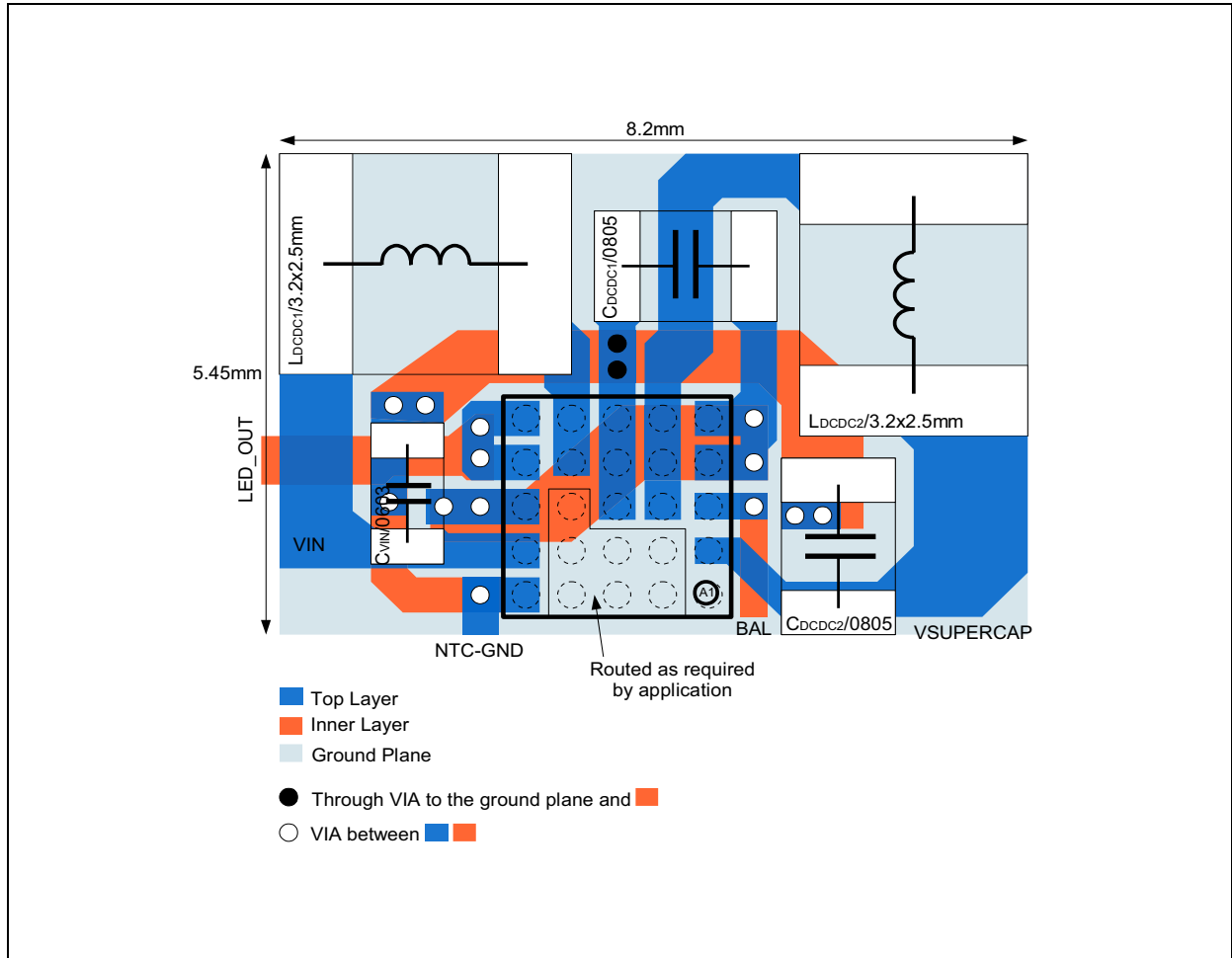

Note: If component placement rules allow, move all components close to the AS3630. The NTC ground connection shall be separated from the main ground and directly connected to AGND (Ball A5). The recommended PCB pad size for the AS3630 is 250µm.

Package Drawings and Markings

Figure AS3630 – 54:
25pin WL-CSP Marking

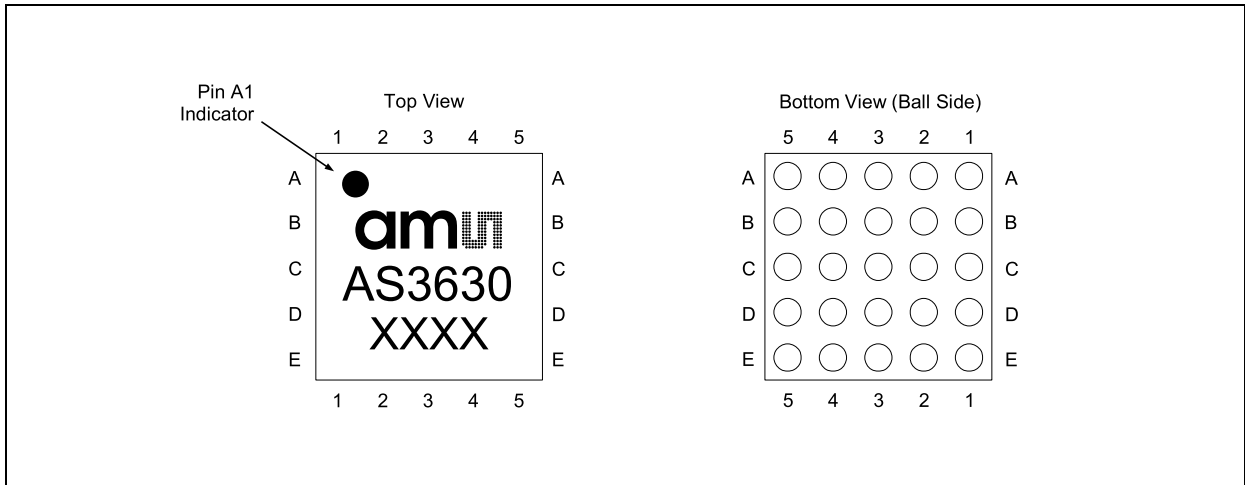

Notes:

1. Line 1 : ams AG logo
2. Line 2 : AS3630
3. Line 3 : <Code> (Encoded Datecode - 4 characters)

Figure AS3630 – 55:
25pin WL-CSP Package Dimensions

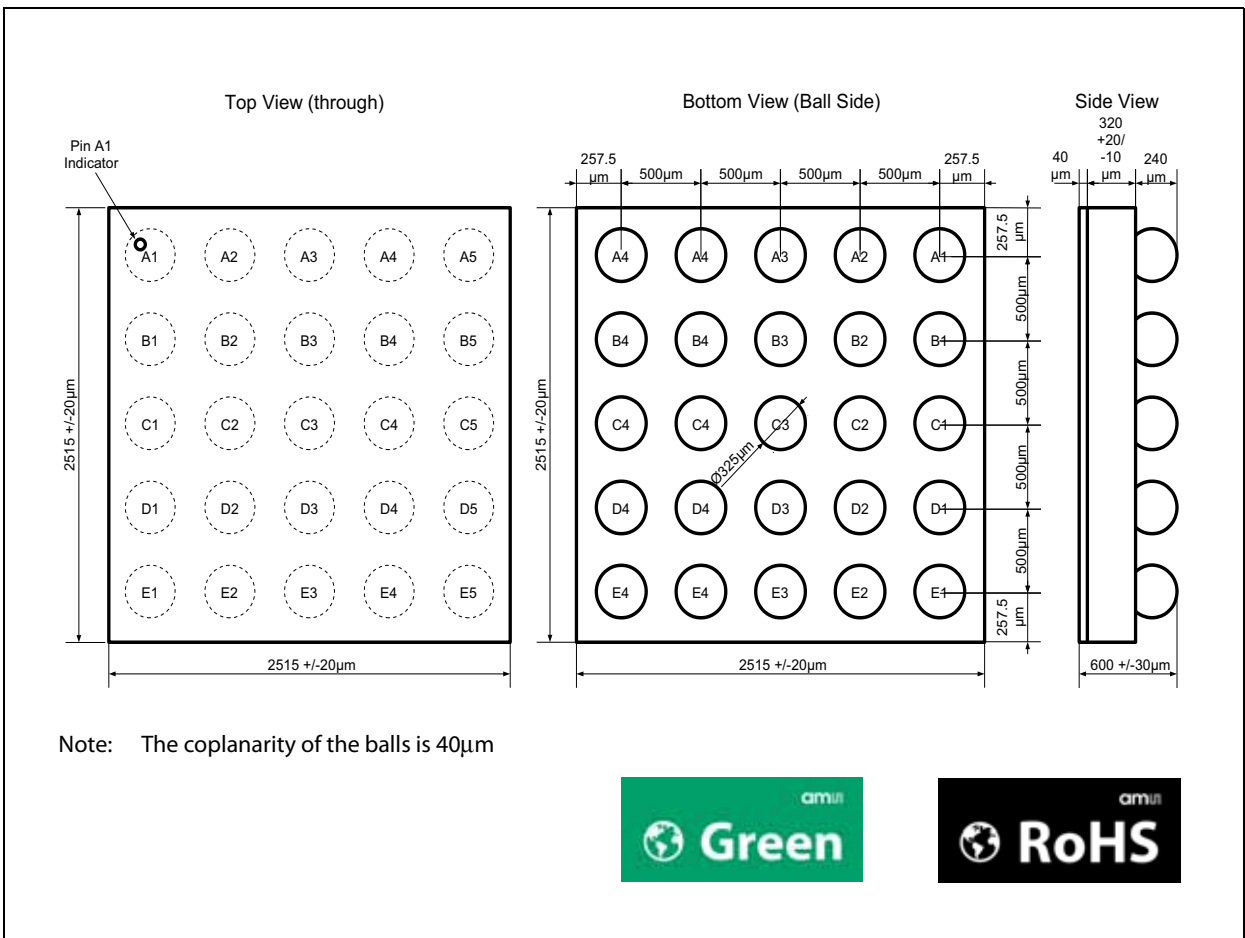

Ordering Information

The devices are available as standard products as shown below.

Figure AS3630 – 56:
Ordering Information

Ordering Code	Description	Delivery	Package
AS3630-ZWLT	8A Supercap Flash Driver with Torch and Indicator	Tape & Reel	25-pin WL-CSP 5x5 balls 0.5mm pitch, 2.5x2.5x0.6mm size RoHS compliant / Pb-Free

AS3630-ZWLT:

AS3630-

Z : Temperature Range: -30°C - 85°C

WL : Package: Wafer Level Chip Scale Package (WL-CSP)

T : Delivery Form: Tape & Reel

Note: All products are RoHS compliant and ams green.
Buy our products or get free samples online at www.ams.com/ICdirect

Technical Support is available at www.ams.com/Technical-Support

For further information and requests, email us at sales@ams.com
(or) find your local distributor at www.ams.com/distributor

Soldering Information

The PCB assembly should be instrumented and the reflow oven's process parameters established to ensure the solder paste manufacturer's reflow profile specification is met during the assembly process. See Figure below.

The maximum PCB temperature recommended by the supplier must not be exceeded.

Figure AS3630 – 57:
Solder Reflow Profile

Profile Feature	Lead-free Assembly
Average ramp-up rate ($T_{S_{max}}$ to T_P)	3 °C/second max.
Preheat <ul style="list-style-type: none"> • Temperature Min ($T_{S_{min}}$) • Temperature Max ($T_{S_{max}}$) • Time (t_L) 	150 °C 200 °C 60 – 120 seconds
Time maintained above: <ul style="list-style-type: none"> • Temperature (T_L) • Time (t_L) 	217 °C 60 – 150 seconds
Peak/classification temperature (T_P)	260 °C
Time within 5 °C of actual peak temperature (T_P)	30 seconds
Ramp-down rate	6 °C/second max.
Time 25 °C to peak temperature	8 minutes max.

JEDEC standard Lead-free reflow profile: According to J-STD-020D.

Figure AS3630 – 58:
Recommended Reflow Soldering Profile

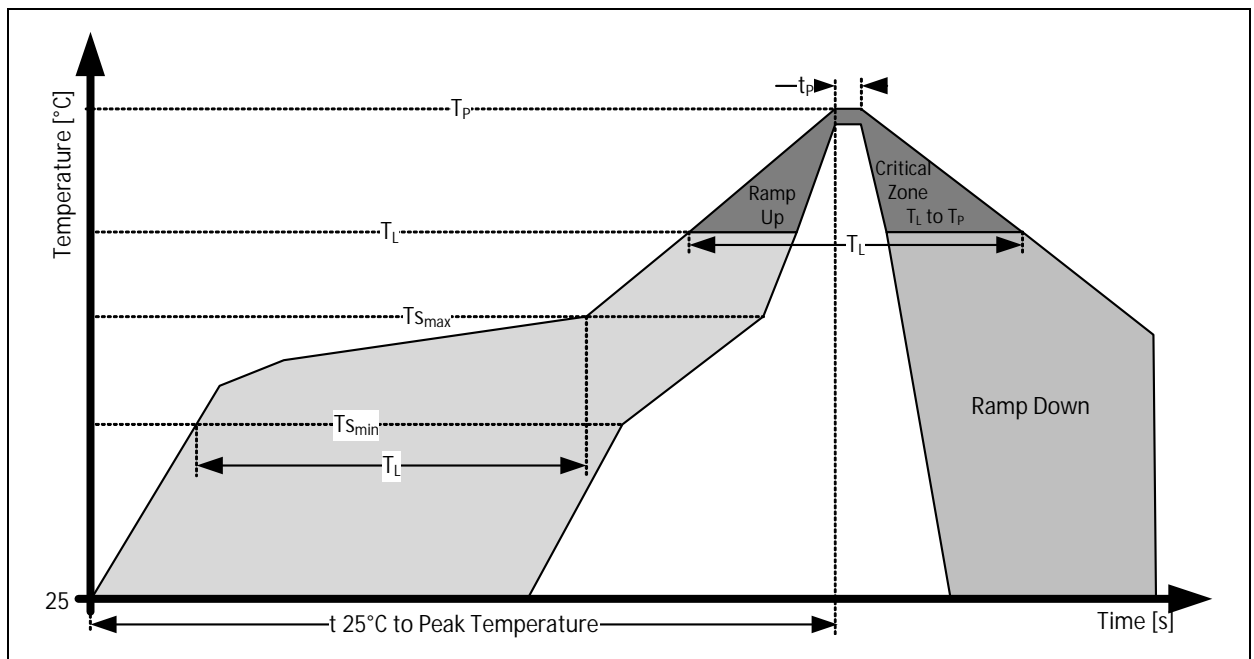

RoHS Compliant and ams Green Statement

The term RoHS compliant means that ams products fully comply with current RoHS directive. Our semiconductor products do not contain any chemicals for all 6 substance categories, including the requirement that lead not exceed 0.1% by weight in homogeneous materials. Where designed to be soldered at high temperatures, RoHS compliant products are suitable for use in specified lead-free processes. ams Green means RoHS compliant and no Sb/Br). ams defines Green that additionally to RoHS compliance our products are free of Bromine (Br) and Antimony (Sb) based flame retardants (Br or Sb do not exceed 0.1% by weight in homogeneous material).

Important Information and Disclaimer The information provided in this statement represents ams knowledge and belief as of the date that it is provided. ams bases its knowledge and belief on information provided by third parties, and makes no representation or warranty as to the accuracy of such information. Efforts are underway to better integrate information from third parties. ams has taken and continues to take reasonable steps to provide representative and accurate information but may not have conducted destructive testing or chemical analysis on incoming materials and chemicals. ams and ams suppliers consider certain information to be proprietary, and thus CAS numbers and other limited information may not be available for release.

Copyrights

Copyright © 1997-2013, ams AG, Tobelbaderstrasse 30, 8141 Unterpremstaetten, Austria-Europe. Trademarks Registered ®. All rights reserved. The material herein may not be reproduced, adapted, merged, translated, stored, or used without the prior written consent of the copyright owner.

Disclaimer

Devices sold by ams AG are covered by the warranty and patent indemnification provisions appearing in its Term of Sale. ams AG makes no warranty, express, statutory, implied, or by description regarding the information set forth herein or regarding the freedom of the described devices from patent infringement. ams AG reserves the right to change specifications and prices at any time and without notice. Therefore, prior to designing this product into a system, it is necessary to check with ams AG for current information. This product is intended for use in normal commercial applications. Applications requiring extended temperature range, unusual environmental requirements, or high reliability applications, such as military, medical life-support or life-sustaining equipment are specifically not recommended without additional processing by ams AG for each application. For shipments of less than 100 parts the manufacturing flow might show deviations from the standard production flow, such as test flow or test location.

The information furnished here by ams AG is believed to be correct and accurate. However, ams AG shall not be liable to recipient or any third party for any damages, including but not limited to personal injury, property damage, loss of profits, loss of use, interruption of business or indirect, special, incidental or consequential damages, of any kind, in connection with or arising out of the furnishing, performance or use of the technical data herein. No obligation or liability to recipient or any third party shall arise or flow out of ams AG rendering of technical or other services.

Компания «Океан Электроники» предлагает заключение долгосрочных отношений при поставках импортных электронных компонентов на взаимовыгодных условиях!

Наши преимущества:

- Поставка оригинальных импортных электронных компонентов напрямую с производств Америки, Европы и Азии, а так же с крупнейших складов мира;
- Широкая линейка поставок активных и пассивных импортных электронных компонентов (более 30 млн. наименований);
- Поставка сложных, дефицитных, либо снятых с производства позиций;
- Оперативные сроки поставки под заказ (от 5 рабочих дней);
- Экспресс доставка в любую точку России;
- Помощь Конструкторского Отдела и консультации квалифицированных инженеров;
- Техническая поддержка проекта, помощь в подборе аналогов, поставка прототипов;
- Поставка электронных компонентов под контролем ВП;
- Система менеджмента качества сертифицирована по Международному стандарту ISO 9001;
- При необходимости вся продукция военного и аэрокосмического назначения проходит испытания и сертификацию в лаборатории (по согласованию с заказчиком);
- Поставка специализированных компонентов военного и аэрокосмического уровня качества (Xilinx, Altera, Analog Devices, Intersil, Interpoint, Microsemi, Actel, Aeroflex, Peregrine, VPT, Syfer, Eurofarad, Texas Instruments, MS Kennedy, Miteq, Cobham, E2V, MA-COM, Hittite, Mini-Circuits, General Dynamics и др.);

Компания «Океан Электроники» является официальным дистрибьютором и эксклюзивным представителем в России одного из крупнейших производителей разъемов военного и аэрокосмического назначения «JONHON», а так же официальным дистрибьютором и эксклюзивным представителем в России производителя высокотехнологичных и надежных решений для передачи СВЧ сигналов «FORSTAR».



JONHON

«JONHON» (основан в 1970 г.)

Разъемы специального, военного и аэрокосмического назначения:

(Применяются в военной, авиационной, аэрокосмической, морской, железнодорожной, горно- и нефтедобывающей отраслях промышленности)

«FORSTAR» (основан в 1998 г.)

ВЧ соединители, коаксиальные кабели,
кабельные сборки и микроволновые компоненты:

(Применяются в телекоммуникациях гражданского и специального назначения, в средствах связи, РЛС, а так же военной, авиационной и аэрокосмической отраслях промышленности).



Телефон: 8 (812) 309-75-97 (многоканальный)

Факс: 8 (812) 320-03-32

Электронная почта: ocean@oceanchips.ru

Web: <http://oceanchips.ru/>

Адрес: 198099, г. Санкт-Петербург, ул. Калинина, д. 2, корп. 4, лит. А