

## 40V/3.0A CV/CC Buck Converter Featuring QC2.0, USB Auto-Detect and USB-PD

### FEATURES

- 12V Input Optimized (Automotive Applications)
- QC2.0 Decoding + USB Auto-Detect + USB-PD Type-C Support
- Apple MFi and 2.4A compatible
- Samsung and BC1.2 compatible
- 40V Input Voltage Surge
- 4.5V-36V Operational Input Voltage
- 5.1V/9.1V Output with +/-1% Accuracy
- Up to 3.0A Output current
- Constant Current Regulation Limit
- Hiccup Mode Protection at Output Short
- >90% Efficiency at Full Load
- 0.5mA Low Standby Input Current
- 5.7V/10.1V Output Over-voltage Protection for 5.1V/9.1V Outputs
- Cord Voltage Compensation
- Meet EN55022 Class B Radiated EMI Standard
- 8kV ESD HBM Protection on DP and DM
- SOP-8EP Package

### APPLICATIONS

- Car Charger
- Cigarette Lighter Adaptor (CLA)
- Rechargeable Portable Device
- CV/CC regulation DC/DC converter

### GENERAL DESCRIPTION

ACT4530 is a wide input voltage, high efficiency step-down DC/DC converter that operates in either CV (Constant Output Voltage) mode or CC (Constant Output Current) mode. It is an improvement over the ACT4529 with its QC2.0 compatibility in 12V automotive applications. The ACT4530 eliminates the issue with QC2.0 buck converters that try to operate with  $V_{in} = 12V$  to  $V_{out} = 12V$ . In addition to QC2.0, it also supports Apple, Samsung and BC1.2 protocols. ACT4530 also has an optional input pin, PDC, that accepts a tri-state input for USB-PD control. The ACT4530 also filters out non-QC2.0 compatible communication pulses generated by some phones' communication protocols.

ACT4530 has accurate output current limits under constant current regulation to meet MFi specification. It provides up to 3.0A output current at 125kHz switching frequency. ACT4530 utilizes adaptive drive technique to achieve good EMI performance while main >90% efficiency at full load for mini size CLA designs. It also has output short circuit protection with hiccup mode. The average output current is reduced to below 6mA when output is shorted to ground. Other features include output over voltage protection and thermal shutdown.

This device is available in a SOP-8EP package and require very few external components for operation.

#### Typical Application Circuit

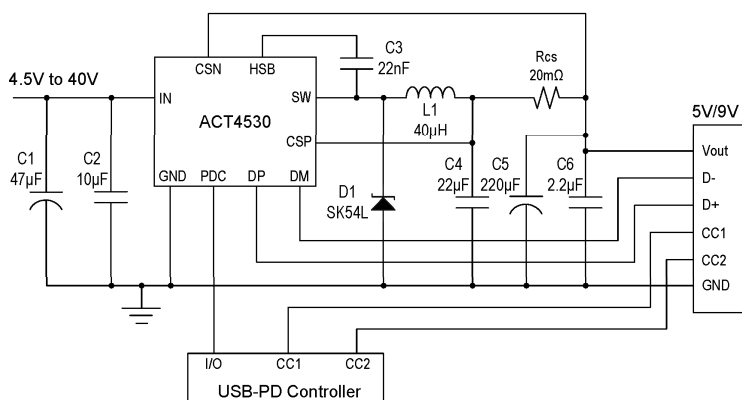

#### V/I Profile

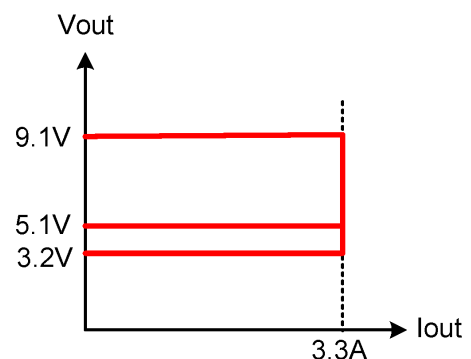

\* Patent Pending

## ORDERING INFORMATION

PART NUMBER	PDC	USB AUTO DETECT	QC2.0	CERTIFICATION	PACKAGE
ACT4530YH-T0010	Yes	No	Yes	n/a	SOP-8EP

## PIN CONFIGURATION

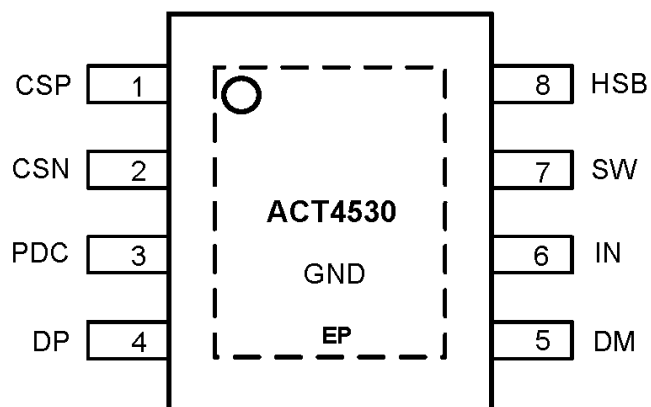

SOP-8EP

Top View

## PIN DESCRIPTIONS

PIN	NAME	DESCRIPTION
1	CSP	Voltage Feedback Input. Connect to node of the inductor and output capacitor. CSP and CSN Kevin sense is recommended.
2	CSN	Negative input terminal of output current sense. Connect to the negative terminal of current sense resistor.
3	PDC	USB-PD Control Pin. When PDC is floating, Vout = 5.1V. When PDC is pulled low, Vout = 9.1V. When PDC is pulled high, the IC ignores the PDC pin and the output voltage does not change from the previous setting.
4	DP	Data Line Positive Input. Connected to D+ of attached portable device data line. This pin passes 8kV HBM ESD.
5	DM	Data Line Negative Input. Connected to D- of attached portable device data line. This pin passes 8kV HBM ESD.
6	IN	Power Supply Input. Bypass this pin with a 10 $\mu$ F ceramic capacitor to GND, placed as close to the IC as possible.
7	SW	Power Switching Output to External Inductor.
8	HSB	High Side Bias Pin. This provides power to the internal high-side MOSFET gate driver. Connect a 22nF capacitor from HSB pin to SW pin.
9	GND	Ground and Heat Dissipation Pad. Connect this exposed pad to large ground copper area with copper and vias.

## ABSOLUTE MAXIMUM RATINGS<sup>①</sup>

PARAMETER	VALUE	UNIT
IN to GND	-0.3 to 40	V
SW to GND	-1 to V <sub>IN</sub> + 1	V
HSB to GND	V <sub>SW</sub> - 0.3 to V <sub>SW</sub> + 7	V
CSP, CSN to GND	-0.3 to +15	V
PDC to GND	-0.3 to +6	V
All other pins to GND	-0.3 to +6	V
Junction to Ambient Thermal Resistance	46	°C/W
Operating Junction Temperature	-40 to 150	°C
Storage Junction Temperature	-55 to 150	°C
Lead Temperature (Soldering 10 sec.)	300	°C

①: Do not exceed these limits to prevent damage to the device. Exposure to absolute maximum rating conditions for long periods may affect device reliability.

## ELECTRICAL CHARACTERISTICS

 ( $V_{IN} = 12V$ ,  $T_A = 25^\circ C$ , unless otherwise specified.)

Parameter	Symbol	Condition	Min	Typ	Max	Units
Input Over Voltage Protection	VIN_OVP	Rising	40	42	44	V
Input Over Voltage Hysteresis				4		V
Input Over Voltage Response Time	T_VIN_OVP	VIN step from 30V to 45V		250		ns
Input Under Voltage Lockout (UVLO)	VIN	Rising		4.5		V
Input UVLO Hysteresis				200		mV
Input Voltage Power Good Deglitch Time		No OVP		40		ms
Input Voltage Power Good Deglitch Time		No UVP		10		us
Input Standby Current		Vin=12V, Vout=5.1V, Iload=0		500		uA
Output Voltage Regulation	CSP	5.1V setting 9.1V setting	5.05 9.0	5.1 9.1	5.15 9.2	V
Output Over Voltage Protection (OVP)		Output rising, 5.1V setting Output rising, 9.1V setting		5.7 10.1		V
Output Over Voltage Deglitch Time				1.0		us
Output Voltage Load Compensation		ACT4530YH-T0010 - 66mV between CSP and CSN	-15%	200	+15%	mV
Output Under Voltage Protection (UVP)	VOUT	VOUT falling	-10%	3.2	10%	V
UVP Hysteresis	VOUT	VOUT rising		0.2		V
UVP Deglitch Time	VOUT			10		us
UVP Blanking Time at Startup				3.5		ms

## ELECTRICAL CHARACTERISTICS

 ( $V_{IN} = 12V$ ,  $T_A = 25^{\circ}C$ , unless otherwise specified.)

Parameter	Symbol	Condition	Min	Typ	Max	Units
Output Constant Current Limit		Rcs=20mΩ	3.1	3.3	3.5	A
Hiccup Waiting Time				4.13		S
Top FET Cycle by Cycle Current Limit			4.5	5.8		A
Top FET Rds on				70		mΩ
Bot FET Rds on				4.7		Ω
Maximum Duty Cycle			99			%
Switching Frequency			-10%	125	+10%	kHz
Soft-start Time				2.0		ms
Out Voltage Ripples		Cout=220uF/22uF ceramic		80		mV
VOUT Discharge Current		For high to lower voltage transitions		60		mA
Voltage transition time for QC 2.0 transition or USB PD Type C		9V-5V			100	ms
Voltage transition time for QC 2.0 transition or USB PD Type C		5V-9V			100	ms
Line Transient Response		Input 12V-40V-12V with 1V/us slew rate, Vout=5V, Iload=0A and 2.4A	4.75		5.25	V
Load Transient Response		80mA-1.0A-80mA load with 0.1A/us slew rate	4.9	5.15	5.4	V
		80mA-1.0A-80mA load with 0.1A/us slew rate	8.7	9.1	9.5	V
Thermal Shut Down				160		°C
Thermal Shut Down Hysteresis				30		°C
ESD of DP, DM		HBM		8		kV
PDC Floating				1.5		V
PDC High			2.0			V
PDC Low					0.8	V
PDC Maximum Voltage					5.5	V
PDC Drive Current				10		uA

## FUNCTIONAL BLOCK DIAGRAM

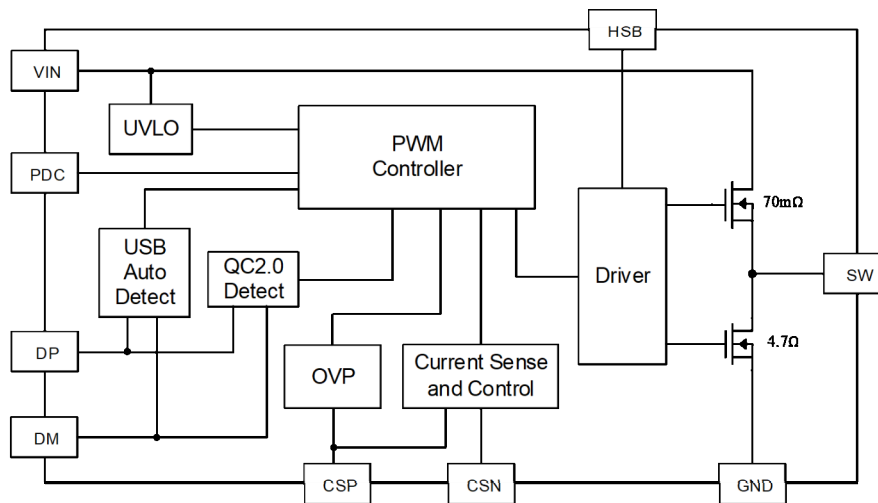

## FUNCTIONAL DESCRIPTION

The ACT4530 is wide input range (40V) buck converter that is optimized for CLA (cigarette lighter adapter) car charger applications. It operates at 125kHz for automotive EMI compatibility. It supports all major communication protocols including Q2.0, USB PD, Apple, Samsung, and BC1.2. It requires very few external components, resulting in small solution sizes.

### Improved QC2.0 Functionality (DP and DM communication)

The ACT4530 implements an improved QC2.0 functionality. It overcomes the typical issues seen with 12V automotive QC2.0 applications that request a 12V output. A typical buck converter cannot deliver a 12V output voltage from a 12V input voltage. The typical buck converter goes to maximum duty cycle and is unable to accurately regulate the output voltage or current. The ACT4530 resolves this issue by accepting all QC2.0 voltage requests, but it only responds to 5V and 9V requests. Any 12V request is ignored, and the output voltage does not change.

### PDC Pin

The PDC pin is an optional input that allows external controllers to program the ACT4530 output voltage. This pin is typically used in USB PD applications. Opening PDC (floating input) programs  $V_{out}$  to 5.1V. Pulling PDC low programs  $V_{out}$  to 9.1V. Pulling PDC high does not change the previously programmed output voltage. Starting the IC with PDC already pulled high results in  $V_{out}$  starting at 5V.

When PDC is pulled high or low, the PDC input takes priority over any DP and DM communication. DP and DM communication requests are only accepted when PDC is floating.

### Output Current Sensing and Regulation

The output current sense resistor is connected between CSP and CSN. The sensed differential voltage is compared with an internal reference voltage to regulate the maximum output current. CC loop and CV loop are in parallel. The current loop response has a slower response compared to voltage loop. During load current transients, the inductor current can be up to +/-25% higher than steady state condition. The customer should confirm that the inductor does not saturate during these peak conditions.

### Cycle-by-Cycle Current Control

The conventional cycle-by-cycle peak current mode is implemented with high-side FET current sense.

### Input Over Voltage Protection

The converter is disabled if the input voltage is above 42V (+/-2V). Device resumes operation automatically 40ms after OVP is cleared.

### Output Over Voltage Protection

Device stops switching when output over-voltage is sensed, and resumes operation automatically when output voltage drops to OVP- hysteresis.

## FUNCTIONAL DESCRIPTION

### Output Over Voltage Discharge

Discharge circuit starts to discharge output through CSP pins when output over voltage is detected. Discharge circuit brings 9V down to 5V in less than 100ms.

### Output Under-Voltage Protection / Hiccup Mode

The ACT4530 implements an under voltage protection (UVP) threshold to protect against fault conditions. If the output voltage is below UVP threshold for more than 10 $\mu$ s, an over current or short circuit is assumed, and the converter goes into hiccup mode by disabling the converter and restarting after hiccup waiting period of 4.3s.

### Thermal Shutdown

If the junction temperature,  $T_J$ , increases beyond 160°C, the ACT4530 shuts down until  $T_J$  drops below 130°C.

### Cord Compensation

The ACT4530 implements cord compensation to account for voltage drops due to output cable resistance. It accomplishes this by increasing the output voltage with increasing output current. The increased output voltage is measured at the CSP pin.

The cord compensation voltage is derived as:

$$\Delta V_{out} = (V_{CSP} - V_{CSN}) * K$$

Where  $K=3.03$

The cord compensation loop is very slow to avoid disturbing to the voltage loop when there are load transients.

## APPLICATIONS INFORMATION

### Inductor Selection

The inductor maintains a continuous current to the output load. This inductor current has a ripple that is dependent on the inductance value.

Higher inductance reduces the peak-to-peak ripple current. The trade off for high inductance value is the increase in inductor core size and series resistance, and the reduction in current handling capability. In general, select an inductance value L based on ripple current requirement:

$$L = \frac{V_{OUT} \times (V_{IN} - V_{OUT})}{V_{IN} f_{SW} I_{LOADMAX} K_{RIPPLE}} \quad (1)$$

Where  $V_{IN}$  is the input voltage,  $V_{OUT}$  is the output voltage,  $f_{SW}$  is the switching frequency,  $I_{LOADMAX}$  is the maximum load current, and  $K_{RIPPLE}$  is the ripple factor. Typically, choose  $K_{RIPPLE} = 30\%$  to correspond to the peak-to-peak ripple current being 30% of the maximum load current.

With a selected inductor value the peak-to-peak inductor current is estimated as:

$$I_{LPK-PK} = \frac{V_{OUT} \times (V_{IN} - V_{OUT})}{L \times V_{IN} \times f_{SW}} \quad (2)$$

The peak inductor current is estimated as:

$$I_{LPK} = I_{LOADMAX} + \frac{1}{2} I_{LPK-PK} \quad (3)$$

The selected inductor should not saturate at  $I_{LPK}$ . The maximum output current is calculated as:

$$I_{OUTMAX} = I_{LIM} - \frac{1}{2} I_{LPK-PK} \quad (4)$$

$I_{LIM}$  is the internal current limit.

### Input Capacitor

The input capacitor needs to be carefully selected to maintain sufficiently low ripple at the supply input of the converter. A low ESR capacitor is highly recommended. Since large currents flow in and out of this capacitor during switching, its ESR also affects efficiency.

The input capacitance needs to be higher than 10 $\mu$ F. The best choice is a ceramic capacitor. However, low ESR tantalum or electrolytic types may also be used provided that the RMS ripple current rating is higher than 50% of the output current. Active Semi recommends using a ceramic

capacitor in parallel with a tantalum or electrolytic. This combination provides the EMI and noise performance. The input capacitor must be placed close to the IN and GND pins of the IC, with the shortest traces possible. If using a tantalum or electrolytic capacitor in parallel with ceramic capacitor, the ceramic capacitor must be placed closer to the IC.

### Output Capacitor

The ACT4530 output capacitance must be split between the left and right side of the output current sense resistor. The left side of the current sense resistor (CSP pin) requires a 22 $\mu$ F ceramic capacitor. The right side of the current sense resistor should contain enough capacitance to keep the output voltage ripple below the require level.

$$V_{RIPPLE} = I_{OUTMAX} K_{RIPPLE} R_{ESR} + \frac{(V_{IN} - V_{OUT}) \times V_{OUT}}{8 \times f_{SW}^2 L C_{OUT} \times V_{IN}} \quad (5)$$

This output capacitance should have low ESR to keep low output voltage ripple. The output ripple voltage is:

Where  $I_{OUTMAX}$  is the maximum output current,  $K_{RIPPLE}$  is the ripple factor,  $R_{ESR}$  is the ESR of the output capacitor,  $f_{SW}$  is the switching frequency, L is the inductor value, and  $C_{OUT}$  is the output capacitance. From the equation above,  $V_{RIPPLE}$  is the combination of ESR and real capacitance.

In the case of ceramic output capacitors,  $R_{ESR}$  is very small and does not contribute to the ripple. Therefore, a lower capacitance value can be used. In the case of tantalum or electrolytic capacitors, the ripple is dominated by  $R_{ESR}$ . In this case, the output capacitor must chosen to have sufficiently low ESR.

For ceramic output capacitors, typically choose a capacitance of about 22 $\mu$ F. For tantalum or electrolytic capacitors, choose a capacitor with less than 50m $\Omega$  ESR. If an 330 $\mu$ F or 470 $\mu$ F electrolytic cap or tantalum cap is used and the output voltage ripple is dominated by ESR, add a 2.2 $\mu$ F ceramic in parallel with the tantalum or electrolytic.

### Rectifier Schottky Diode

Use a Schottky diode as the rectifier to conduct current when the High-Side Power Switch is off. The Schottky diode must have current rating higher than the maximum output current and a reverse voltage rating higher than the maximum input voltage. Further more, the low forward voltage Schottky is preferable for high efficiency and smoothly operation.



## APPLICATIONS INFORMATION

### Current Sense Resistor

The traces leading to and from the sense resistor can be significant error sources. With small value sense resistors, trace resistance shared with the load can cause significant errors. It is recommended to connect the sense resistor pads directly to the CSP and CSN pins using “Kelvin” or “4-wire” connection techniques as shown below.

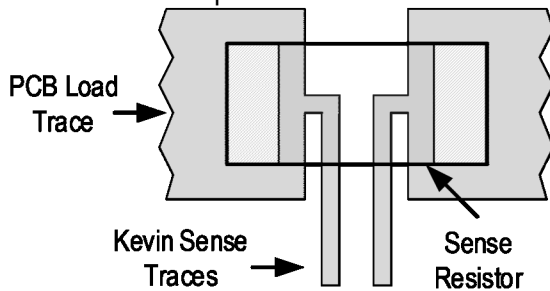

### Current Limit Setting

If output current hits current limit, output voltage drops to keep the current to a constant value.

The following equation calculates the constant current limit.

$$I_{Limit} (A) = \frac{66 mV}{R_{cs} (m\Omega)} \quad (6)$$

Where  $R_{cs}$  is current sense resistor.

## APPLICATIONS INFORMATION

### PCB Layout Guidance

When laying out the printed circuit board, the following checklist should be used to ensure proper operation of the IC.

- 1) Arrange the power components to reduce the AC loop size consisting of  $C_{IN}$ ,  $V_{IN}$  pin, SW pin and the Schottky diode.
- 2) The high power loss components, e.g. the controller, Schottky diode, and the inductor should be placed carefully to make the thermal spread evenly on the board.
- 3) Place input decoupling ceramic capacitor  $C_{IN}$  as close as possible to the  $V_{IN}$  pin and power pad.  $C_{IN}$  must be connected to power GND with a short and wide copper trace.
- 4) Schottky anode pad and IC exposed pad should be placed close to ground clips in CLA applications
- 5) Use “Kelvin” or “4-wire” connection techniques from the sense resistor pads directly to the CSP and CSN pins. The CSP and CSN traces should be in parallel to avoid interference.
- 6) Place multiple vias between top and bottom GND planes for best heat dissipation and noise immunity.
- 7) Use short traces connecting HSB- $C_{HSB}$ -SW loop.
- 8) SW pad is noise node switching from  $V_{IN}$  to GND. It should be isolated away from the rest of circuit for good EMI and low noise operation.

### Example PCB Layout

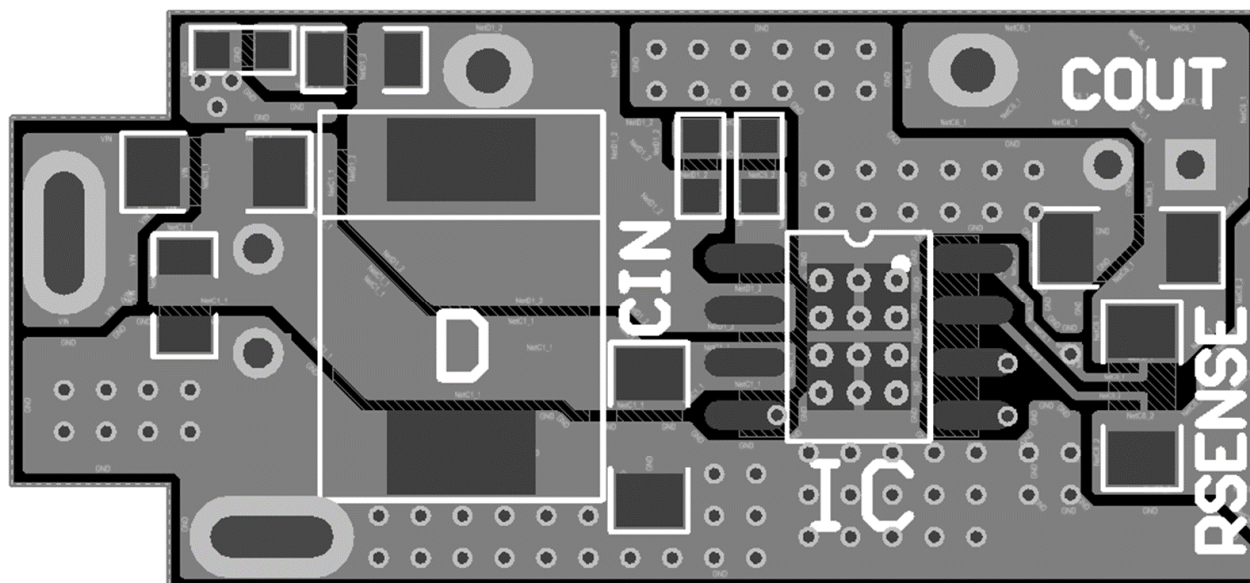

## Typical Application Circuit

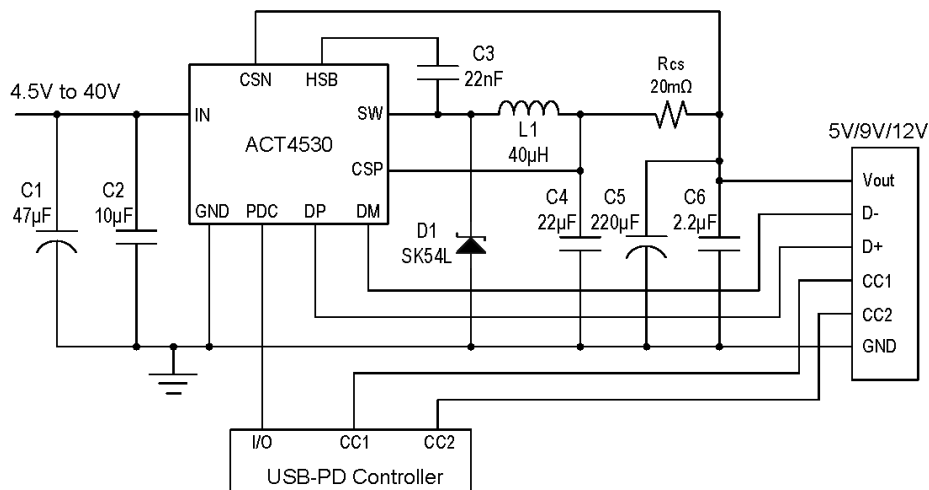

## BOM List for 2.4A Car Charger

ITEM	REFERENCE	DESCRIPTION	MANUFACTURER	QTY
1	U1	IC, ACT4530, SOP-8EP	Active-Semi	1
2	C1	Capacitor, Electrolytic, 47µF/35V	Murata, TDK	1
3	C2	Capacitor, Ceramic, 10µF/25V, 1206, SMD	Murata, TDK	1
4	C3	Capacitor, Ceramic, 22nF/25V, 0603, SMD	Murata, TDK	1
5	C4	Capacitor, Ceramic, 22µF/16V, 1206, SMD	Murata, TDK	1
6	C5	Capacitor, Electrolytic, 220µF/16V	Murata, TDK	1
7	C6	Capacitor, Ceramic, 2.2µF/16V, 0805, SMD	Murata, TDK	1
8	L1	Inductor, 40µH, 4A, 20%		1
9	D1	Diode, Schottky, 40V/5A, SK54L	Panjit	1
10	Rcs	Chip Resistor, 20mΩ, 1206, 1%	Murata, TDK	1

## TYPICAL PERFORMANCE CHARACTERISTICS

(Schematic as show in typical application circuit, Ta = 25°C, unless otherwise specified)

**Efficiency vs. Load current ( 5V Vout)**

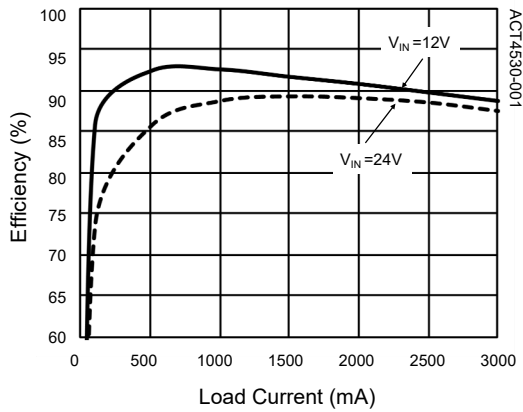

**Efficiency vs. Load current ( 9V Vout)**

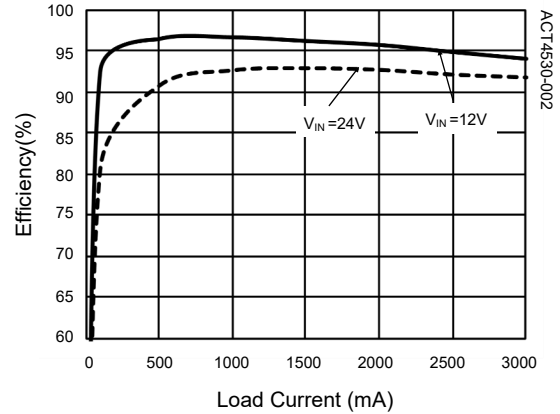

**Output CC/CV Curve (5V Vout)**

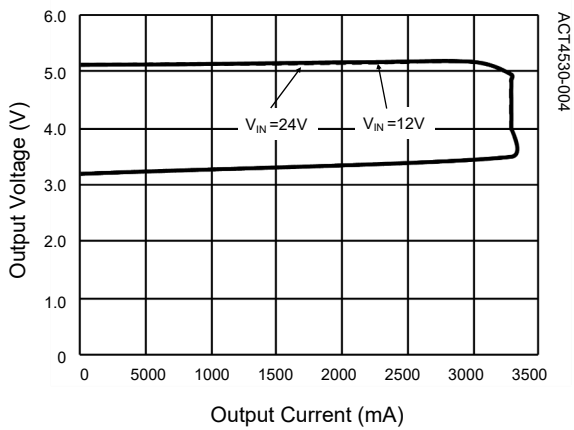

**Output CC/CV Curve (9V Vout)**

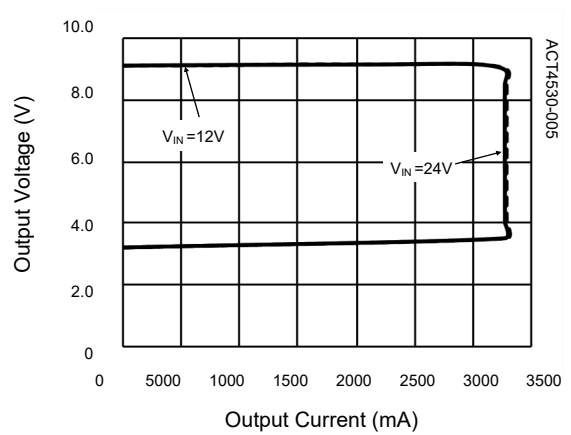

## TYPICAL PERFORMANCE CHARACTERISTICS

(Schematic as show in typical application circuit, Ta = 25°C, unless otherwise specified)

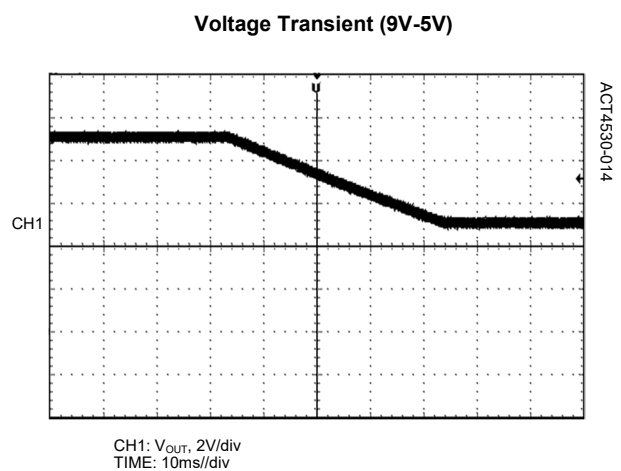
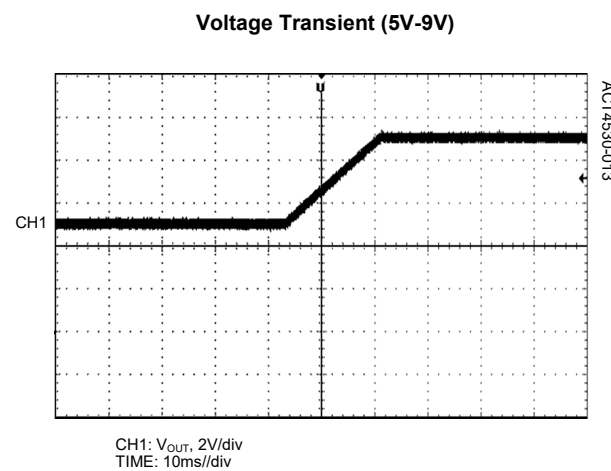
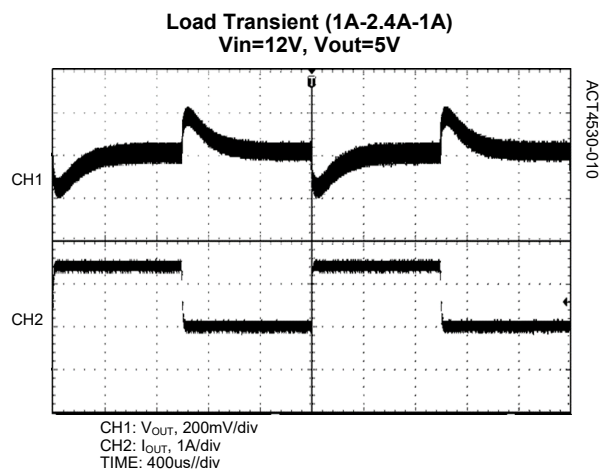
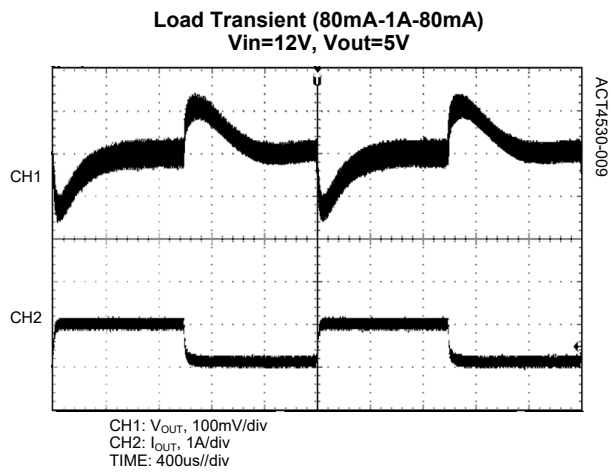
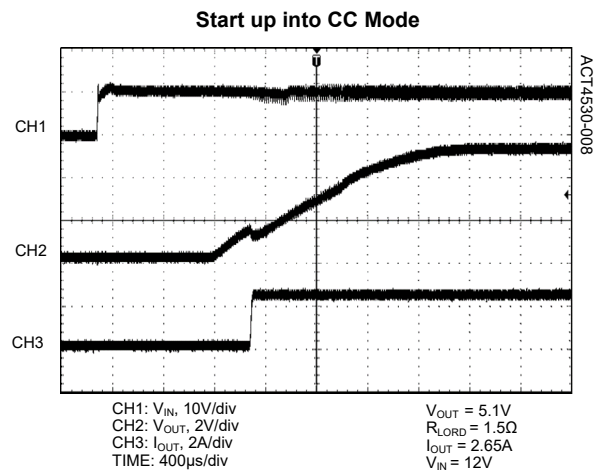
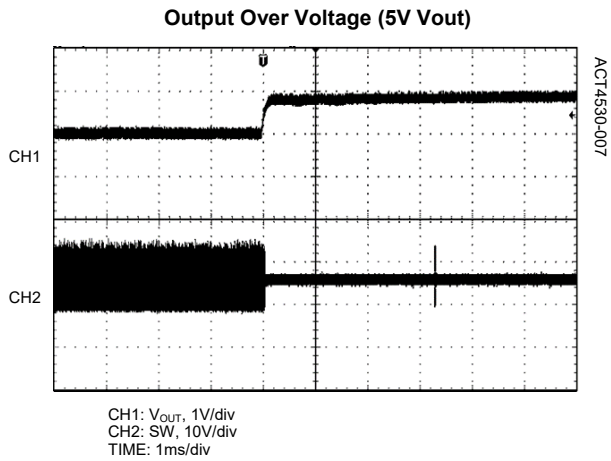

## PACKAGE OUTLINE

### SOP-8EP PACKAGE OUTLINE AND DIMENSIONS

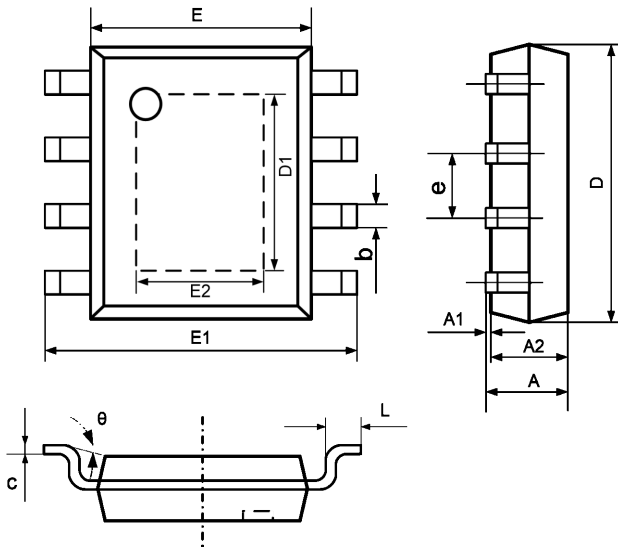

SYMBOL	DIMENSION IN MILLIMETERS		DIMENSION IN INCHES	
	MIN	MAX	MIN	MAX
A	1.350	1.727	0.053	0.068
A1	0.000	0.152	0.000	0.006
A2	1.245	1.550	0.049	0.061
b	0.330	0.510	0.013	0.020
c	0.170	0.250	0.007	0.010
D	4.700	5.100	0.185	0.200
D1	3.202	3.402	0.126	0.134
E	3.734	4.000	0.147	0.157
E1	5.800	6.200	0.228	0.244
E2	2.313	2.513	0.091	0.099
e	1.270 TYP		0.050 TYP	
L	0.400	1.270	0.016	0.050
θ	0°	8°	0°	8°

Active-Semi, Inc. reserves the right to modify the circuitry or specifications without notice. Users should evaluate each product to make sure that it is suitable for their applications. Active-Semi products are not intended or authorized for use as critical components in life-support devices or systems. Active-Semi, Inc. does not assume any liability arising out of the use of any product or circuit described in this datasheet, nor does it convey any patent license.

Active-Semi and its logo are trademarks of Active-Semi, Inc. For more information on this and other products, contact [sales@active-semi.com](mailto:sales@active-semi.com) or visit <http://www.active-semi.com>.

 active-semi<sup>®</sup> is a registered trademark of Active-Semi.

Компания «Океан Электроники» предлагает заключение долгосрочных отношений при поставках импортных электронных компонентов на взаимовыгодных условиях!

Наши преимущества:

- Поставка оригинальных импортных электронных компонентов напрямую с производств Америки, Европы и Азии, а так же с крупнейших складов мира;
- Широкая линейка поставок активных и пассивных импортных электронных компонентов (более 30 млн. наименований);
- Поставка сложных, дефицитных, либо снятых с производства позиций;
- Оперативные сроки поставки под заказ (от 5 рабочих дней);
- Экспресс доставка в любую точку России;
- Помощь Конструкторского Отдела и консультации квалифицированных инженеров;
- Техническая поддержка проекта, помощь в подборе аналогов, поставка прототипов;
- Поставка электронных компонентов под контролем ВП;
- Система менеджмента качества сертифицирована по Международному стандарту ISO 9001;
- При необходимости вся продукция военного и аэрокосмического назначения проходит испытания и сертификацию в лаборатории (по согласованию с заказчиком);
- Поставка специализированных компонентов военного и аэрокосмического уровня качества (Xilinx, Altera, Analog Devices, Intersil, Interpoint, Microsemi, Actel, Aeroflex, Peregrine, VPT, Syfer, Eurofarad, Texas Instruments, MS Kennedy, Miteq, Cobham, E2V, MA-COM, Hittite, Mini-Circuits, General Dynamics и др.);

Компания «Океан Электроники» является официальным дистрибьютором и эксклюзивным представителем в России одного из крупнейших производителей разъемов военного и аэрокосмического назначения «JONHON», а так же официальным дистрибьютором и эксклюзивным представителем в России производителя высокотехнологичных и надежных решений для передачи СВЧ сигналов «FORSTAR».



## JONHON

«JONHON» (основан в 1970 г.)

Разъемы специального, военного и аэрокосмического назначения:

(Применяются в военной, авиационной, аэрокосмической, морской, железнодорожной, горно- и нефтедобывающей отраслях промышленности)

«FORSTAR» (основан в 1998 г.)

ВЧ соединители, коаксиальные кабели, кабельные сборки и микроволновые компоненты:

(Применяются в телекоммуникациях гражданского и специального назначения, в средствах связи, РЛС, а так же военной, авиационной и аэрокосмической отраслях промышленности).



Телефон: 8 (812) 309-75-97 (многоканальный)

Факс: 8 (812) 320-03-32

Электронная почта: [ocean@oceanchips.ru](mailto:ocean@oceanchips.ru)

Web: <http://oceanchips.ru/>

Адрес: 198099, г. Санкт-Петербург, ул. Калинина, д. 2, корп. 4, лит. А