

## General Description

With its unique array of configurable blocks, PSoC<sup>®</sup> 3 is a true system level solution providing microcontroller unit (MCU), memory, analog, and digital peripheral functions in a single chip. The CY8C32 family offers a modern method of signal acquisition, signal processing, and control with high accuracy, high bandwidth, and high flexibility. Analog capability spans the range from thermocouples (near DC voltages) to ultrasonic signals. The CY8C32 family can handle dozens of data acquisition channels and analog inputs on every general-purpose input/output (GPIO) pin. The CY8C32 family is also a high-performance configurable digital system with some part numbers including interfaces such as USB, and multimaster inter-integrated circuit (I<sup>2</sup>C). In addition to communication interfaces, the CY8C32 family has an easy to configure logic array, flexible routing to all I/O pins, and a high-performance single cycle 8051 microprocessor core. You can easily create system-level designs using a rich library of prebuilt components and boolean primitives using PSoC Creator™, a hierarchical schematic design entry tool. The CY8C32 family provides unparalleled opportunities for analog and digital bill of materials integration while easily accommodating last minute design changes through simple firmware updates.

## Features

- Single cycle 8051 CPU core
  - DC to 50 MHz operation
  - Multiply and divide instructions
  - Flash program memory, up to 64 KB, 100,000 write cycles, 20 years retention, and multiple security features
  - Up to 8-KB flash error correcting code (ECC) or configuration storage
  - Up to 8 KB SRAM
  - Up to 2 KB electrically erasable programmable read-only memory (EEPROM), 1 M cycles, and 20 years retention
  - 24-channel direct memory access (DMA) with multilayer AHB<sup>[1]</sup> bus access
    - Programmable chained descriptors and priorities
    - High bandwidth 32-bit transfer support
- Low voltage, ultra low-power
  - Wide operating voltage range: 0.5 V to 5.5 V
  - High efficiency boost regulator from 0.5-V through 1.8-V to 5.0-V output
  - 0.8 mA at 3 MHz, 1.2 mA at 6 MHz, and 6.6 mA at 50 MHz
  - Low-power modes including:
    - 1-μA sleep mode with real-time clock (RTC) and low-voltage detect (LVD) interrupt
    - 200-nA hibernate mode with RAM retention
- Versatile I/O system
  - 28 to 72 I/O (62 GPIOs, eight special input/outputs (SIO), two USBIOs<sup>[2]</sup>)
  - Any GPIO to any digital or analog peripheral routability
  - LCD direct drive from any GPIO, up to 46×16 segments<sup>[2]</sup>
  - CapSense<sup>®</sup> support from any GPIO<sup>[3]</sup>
  - 1.2-V to 5.5-V I/O interface voltages, up to four domains
  - Maskable, independent IRQ on any pin or port
  - Schmitt-trigger transistor-transistor logic (TTL) inputs
  - All GPIO configurable as open drain high/low, pull-up/pull-down, High Z, or strong output
  - Configurable GPIO pin state at power-on reset (POR)
  - 25 mA sink on SIO
- Digital peripherals
  - 16 to 24 programmable PLD based universal digital blocks (UDB)
    - Full-speed (FS) USB 2.0 12 Mbps using internal oscillator<sup>[2]</sup>
    - Up to four 16-bit configurable timer, counter, and PWM blocks
    - Library of standard peripherals
      - 8-, 16-, 24-, and 32-bit timers, counters, and PWMs
      - Serial peripheral interface (SPI), universal asynchronous transmitter receiver (UART), and I<sup>2</sup>C
      - Many others available in catalog
    - Library of advanced peripherals
      - Cyclic redundancy check (CRC)
      - Pseudo random sequence (PRS) generator
      - Local interconnect network (LIN) bus 2.0
      - Quadrature decoder
  - Analog peripherals (1.71 V ≤ V<sub>D<sub>DA</sub></sub> ≤ 5.5 V)
    - 1.024 V ±0.9-percent internal voltage reference across -40°C to +85°C (14 ppm/°C)
    - Configurable delta-sigma ADC with 8- to 12-bit resolution
      - Programmable gain stage: ×0.25 to ×16
      - 12-bit mode, 192-ksps, 66-dB signal to noise and distortion ratio (SINAD), ±1-bit INL/DNL
    - One 8-bit, 8-Msps IDAC or 1-Msps VDAC
    - Two comparators with 95 ns response time
    - CapSense support
  - Programming, debug, and trace
    - JTAG (4-wire), serial wire debug (SWD) (2-wire), and single wire viewer (SWV) interfaces
    - Eight address and one data breakpoint
    - 4-KB instruction trace buffer
    - Bootloader programming supportable through I<sup>2</sup>C, SPI, UART, USB, and other interfaces
  - Precision, programmable clocking
    - 3- to 24-MHz internal oscillator over full temperature and voltage range
    - 4- to 25-MHz crystal oscillator for crystal PPM accuracy
    - Internal PLL clock generation up to 50 MHz
    - 32.768-kHz watch crystal oscillator
    - Low-power internal oscillator at 1, 33, and 100 kHz
  - Temperature and packaging
    - -40°C to +85°C degrees industrial temperature
    - 48-pin SSOP, 48-pin QFN, 68-pin QFN, and 100-pin TQFP package options

### Notes

1. AHB – AMBA (advanced microcontroller bus architecture) high-performance bus, an ARM data transfer bus
2. This feature on select devices only. See [Ordering Information](#) on page 108 for details.
3. GPIOs with opamp outputs are not recommended for use with CapSense.

## Contents

<b>1. Architectural Overview</b> .....	<b>3</b>	8.5 CapSense .....	57
<b>2. Pinouts</b> .....	<b>5</b>	8.6 Temp Sensor .....	57
<b>3. Pin Descriptions</b> .....	<b>10</b>	8.7 DAC .....	58
<b>4. CPU</b> .....	<b>11</b>	<b>9. Programming, Debug Interfaces, Resources</b> .....	<b>59</b>
4.1 8051 CPU .....	11	9.1 JTAG Interface .....	59
4.2 Addressing Modes .....	11	9.2 Serial Wire Debug Interface .....	61
4.3 Instruction Set .....	12	9.3 Debug Features .....	62
4.4 DMA and PHUB .....	16	9.4 Trace Features .....	62
4.5 Interrupt Controller .....	18	9.5 Single Wire Viewer Interface .....	62
<b>5. Memory</b> .....	<b>22</b>	9.6 Programming Features .....	62
5.1 Static RAM .....	22	9.7 Device Security .....	62
5.2 Flash Program Memory .....	22	<b>10. Development Support</b> .....	<b>63</b>
5.3 Flash Security .....	22	10.1 Documentation .....	63
5.4 EEPROM .....	22	10.2 Online .....	63
5.5 Nonvolatile Latches (NVLs) .....	23	10.3 Tools .....	63
5.6 External Memory Interface .....	24	<b>11. Electrical Specifications</b> .....	<b>64</b>
5.7 Memory Map .....	24	11.1 Absolute Maximum Ratings .....	64
<b>6. System Integration</b> .....	<b>26</b>	11.2 Device Level Specifications .....	65
6.1 Clocking System .....	26	11.3 Power Regulators .....	69
6.2 Power System .....	29	11.1 Inputs and Outputs .....	73
6.3 Reset .....	33	11.2 Analog Peripherals .....	81
6.4 I/O System and Routing .....	34	11.3 Digital Peripherals .....	93
<b>7. Digital Subsystem</b> .....	<b>40</b>	11.4 Memory .....	96
7.1 Example Peripherals .....	41	11.5 PSoC System Resources .....	102
7.2 Universal Digital Block .....	44	11.6 Clocking .....	104
7.3 UDB Array Description .....	47	<b>12. Ordering Information</b> .....	<b>108</b>
7.4 DSI Routing Interface Description .....	47	12.1 Part Numbering Conventions .....	109
7.5 USB .....	49	<b>13. Packaging</b> .....	<b>110</b>
7.6 Timers, Counters, and PWMs .....	49	<b>14. Acronyms</b> .....	<b>113</b>
7.7 I <sup>2</sup> C .....	49	<b>15. Reference Documents</b> .....	<b>114</b>
<b>8. Analog Subsystem</b> .....	<b>51</b>	<b>16. Document Conventions</b> .....	<b>115</b>
8.1 Analog Routing .....	52	16.1 Units of Measure .....	115
8.2 Delta-sigma ADC .....	54	<b>17. Revision History</b> .....	<b>116</b>
8.3 Comparators .....	55	<b>18. Sales, Solutions, and Legal Information</b> .....	<b>120</b>
8.4 LCD Direct Drive .....	57		

## 1. Architectural Overview

Introducing the CY8C32 family of ultra low-power, flash Programmable System-on-Chip (PSoC<sup>®</sup>) devices, part of a scalable 8-bit PSoC 3 and 32-bit PSoC 5 platform. The CY8C32 family provides configurable blocks of analog, digital, and interconnect circuitry around a CPU subsystem. The combination of a CPU with a flexible analog subsystem, digital subsystem, routing, and I/O enables a high level of integration in a wide variety of consumer, industrial, and medical applications.

Figure 1-1. Simplified Block Diagram

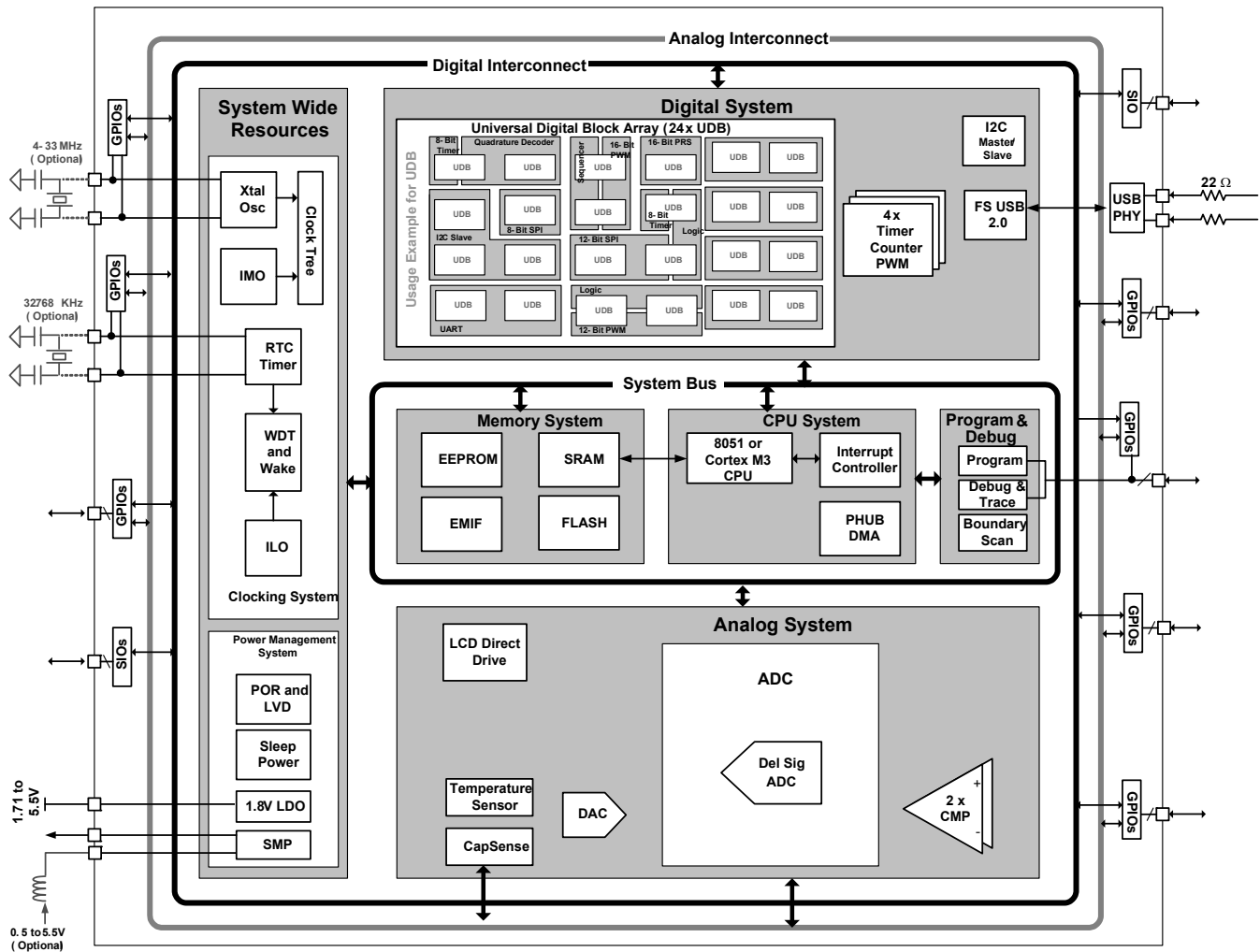


Figure 1-1 illustrates the major components of the CY8C32 family. They are:

- 8051 CPU subsystem
- Nonvolatile subsystem
- Programming, debug, and test subsystem
- Inputs and outputs
- Clocking
- Power
- Digital subsystem
- Analog subsystem

PSoC's digital subsystem provides half of its unique configurability. It connects a digital signal from any peripheral to any pin through the Digital System Interconnect (DSI). It also provides functional flexibility through an array of small, fast, low-power UDBs. PSoC Creator provides a library of prebuilt and tested standard digital peripherals (UART, SPI, LIN, PRS, CRC, timer, counter, PWM, AND, OR, and so on) that are mapped to the UDB array. You can also easily create a digital circuit using boolean primitives by means of graphical design entry. Each UDB contains programmable array logic (PAL)/programmable logic device (PLD) functionality, together with a small state machine engine to support a wide variety of peripherals.

In addition to the flexibility of the UDB array, PSoC also provides configurable digital blocks targeted at specific functions. For the CY8C32 family these blocks can include four 16-bit timers, counters, and PWM blocks; I<sup>2</sup>C slave, master, and multimaster; and FS USB.

For more details on the peripherals see the “[Example Peripherals](#)” section on page 41 of this datasheet. For information on UDBs, DSI, and other digital blocks, see the “[Digital Subsystem](#)” section on page 40 of this datasheet.

PSoC’s analog subsystem is the second half of its unique configurability. All analog performance is based on a highly accurate absolute voltage reference with less than 0.9-percent error over temperature and voltage. The configurable analog subsystem includes:

- Analog muxes
- Comparators
- Voltage references
- ADC
- DAC

All GPIO pins can route analog signals into and out of the device using the internal analog bus. This allows the device to interface up to 62 discrete analog signals. The heart of the analog subsystem is a fast, accurate, configurable delta-sigma ADC with these features:

- Less than 100  $\mu$ V offset
- A gain error of 0.2 percent
- INL less than  $\pm 1$  LSB
- DNL less than  $\pm 1$  LSB
- SINAD better than 66 dB

This converter addresses a wide variety of precision analog applications, including some of the most demanding sensors.

A high-speed voltage or current DAC supports 8-bit output signals at an update rate of 8 Msps in current DAC (IDAC) and 1 Msps in voltage DAC (VDAC). It can be routed out of any GPIO pin. You can create higher resolution voltage PWM DAC outputs using the UDB array. This can be used to create a pulse width modulated (PWM) DAC of up to 10 bits, at up to 48 kHz. The digital DACs in each UDB support PWM, PRS, or delta-sigma algorithms with programmable widths.

In addition to the ADC and DAC, the analog subsystem provides multiple comparators.

See the “[Analog Subsystem](#)” section on page 51 of this datasheet for more details.

PSoC’s 8051 CPU subsystem is built around a single cycle pipelined 8051 8-bit processor running at up to 50 MHz. The CPU subsystem includes a programmable nested vector interrupt controller, DMA controller, and RAM. PSoC’s nested vector interrupt controller provides low latency by allowing the CPU to vector directly to the first address of the interrupt service routine, bypassing the jump instruction required by other architectures. The DMA controller enables peripherals to

exchange data without CPU involvement. This allows the CPU to run slower (saving power) or use those CPU cycles to improve the performance of firmware algorithms. The single cycle 8051 CPU runs ten times faster than a standard 8051 processor. The processor speed itself is configurable, allowing you to tune active power consumption for specific applications.

PSoC’s nonvolatile subsystem consists of flash, byte-writable EEPROM, and nonvolatile configuration options. It provides up to 64 KB of on-chip flash. The CPU can reprogram individual blocks of flash, enabling bootloaders. You can enable an ECC for high reliability applications. A powerful and flexible protection model secures the user’s sensitive information, allowing selective memory block locking for read and write protection. Up to 2 KB of byte-writable EEPROM is available on-chip to store application data. Additionally, selected configuration options such as boot speed and pin drive mode are stored in nonvolatile memory. This allows settings to activate immediately after POR.

The three types of PSoC I/O are extremely flexible. All I/Os have many drive modes that are set at POR. PSoC also provides up to four I/O voltage domains through the V<sub>DDIO</sub> pins. Every GPIO has analog I/O, LCD drive<sup>[4]</sup>, CapSense<sup>[5]</sup>, flexible interrupt generation, slew rate control, and digital I/O capability. The SIOs on PSoC allow V<sub>oh</sub> to be set independently of V<sub>DDIO</sub> when used as outputs. When SIOs are in input mode they are high impedance. This is true even when the device is not powered or when the pin voltage goes above the supply voltage. This makes the SIO ideally suited for use on an I<sup>2</sup>C bus where the PSoC may not be powered when other devices on the bus are. The SIO pins also have high current sink capability for applications such as LED drives. The programmable input threshold feature of the SIO can be used to make the SIO function as a general purpose analog comparator. For devices with FS USB the USB physical interface is also provided (USBIO). When not using USB these pins may also be used for limited digital functionality and device programming. All of the features of the PSoC I/Os are covered in detail in the “[I/O System and Routing](#)” section on page 34 of this datasheet.

The PSoC device incorporates flexible internal clock generators, designed for high stability and factory trimmed for high accuracy. The Internal Main Oscillator (IMO) is the master clock base for the system, and has 1-percent accuracy at 3 MHz. The IMO can be configured to run from 3 MHz up to 24 MHz. Multiple clock derivatives can be generated from the main clock frequency to meet application needs. The device provides a PLL to generate system clock frequencies up to 50 MHz from the IMO, external crystal, or external reference clock. It also contains a separate, very low-power Internal Low-Speed Oscillator (ILO) for the sleep and watchdog timers. A 32.768-kHz external watch crystal is also supported for use in RTC applications. The clocks, together with programmable clock dividers, provide the flexibility to integrate most timing requirements.

The CY8C32 family supports a wide supply operating range from 1.71 V to 5.5 V. This allows operation from regulated supplies such as 1.8  $\pm$  5 percent, 2.5 V  $\pm$  10 percent, 3.3 V  $\pm$  10 percent, or 5.0 V  $\pm$  10 percent, or directly from a wide range of battery types. In addition, it provides an integrated high efficiency synchronous boost converter that can power the device from supply voltages as low as 0.5 V.

**Notes**

4. This feature on select devices only. See [Ordering Information](#) on page 108 for details.
5. GPIOs with opamp outputs are not recommended for use with CapSense.

This enables the device to be powered directly from a single battery or solar cell. In addition, you can use the boost converter to generate other voltages required by the device, such as a 3.3-V supply for LCD glass drive. The boost's output is available on the V<sub>BOOST</sub> pin, allowing other devices in the application to be powered from the PSoC.

PSoC supports a wide range of low-power modes. These include a 200-nA hibernate mode with RAM retention and a 1-μA sleep mode with RTC. In the second mode the optional 32.768-kHz watch crystal runs continuously and maintains an accurate RTC.

Power to all major functional blocks, including the programmable digital and analog peripherals, can be controlled independently by firmware. This allows low-power background processing when some peripherals are not in use. This, in turn, provides a total device current of only 1.2 mA when the CPU is running at 6 MHz, or 0.8 mA running at 3 MHz.

The details of the PSoC power modes are covered in the “Power System” section on page 29 of this datasheet.

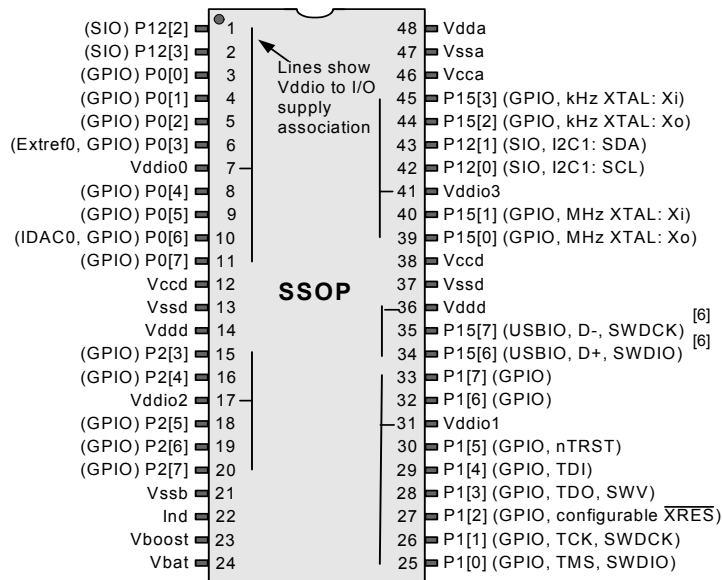
PSoC uses JTAG (4-wire) or SWD (2-wire) interfaces for programming, debug, and test. The 1-wire SWV may also be used for “printf” style debugging. By combining SWD and SWV,

you can implement a full debugging interface with just three pins. Using these standard interfaces enables you to debug or program the PSoC with a variety of hardware solutions from Cypress or third party vendors. PSoC supports on-chip break points and 4-KB instruction and data race memory for debug. Details of the programming, test, and debugging interfaces are discussed in the “Programming, Debug Interfaces, Resources” section on page 59 of this datasheet.

## 2. Pinouts

The V<sub>ddio</sub> pin that supplies a particular set of pins is indicated by the black lines drawn on the pinout diagrams in Figure 2-1 through Figure 2-4. Using the V<sub>ddio</sub> pins, a single PSoC can support multiple interface voltage levels, eliminating the need for off-chip level shifters. Each V<sub>ddio</sub> may sink up to 100 mA total to its associated I/O pins. On the 68 pin and 100 pin devices each set of V<sub>ddio</sub> associated pins may sink up to 100 mA. The 48-pin device may sink up to 100 mA total for all V<sub>ddio0</sub> plus V<sub>ddio2</sub> associated I/O pins and 100 mA total for all V<sub>ddio1</sub> plus V<sub>ddio3</sub> associated I/O pins.

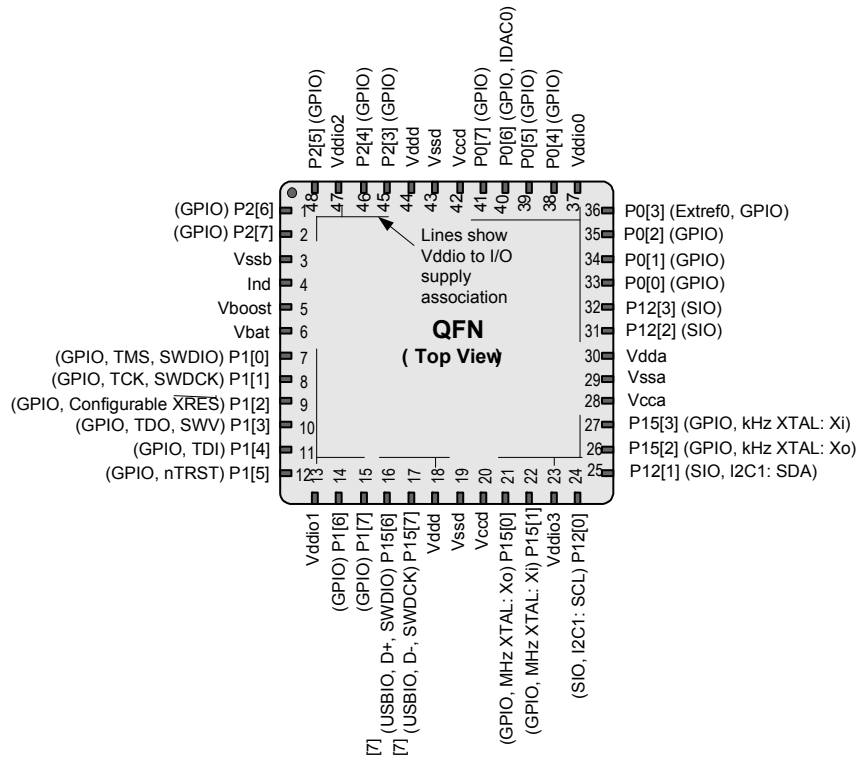
**Figure 2-1. 48-pin SSOP Part Pinout**



**Note**

6. Pins are Do Not Use (DNU) on devices without USB. The pin must be left floating.

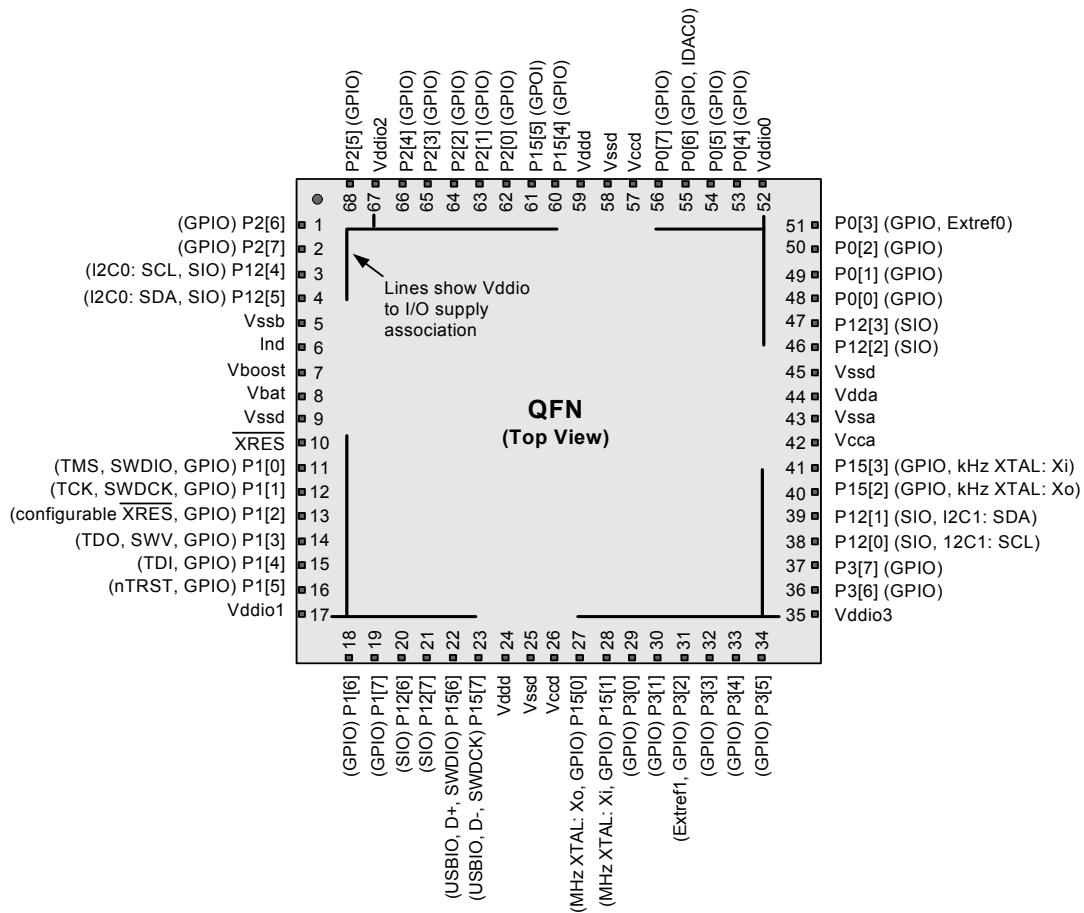
**Figure 2-2. 48-pin QFN Part Pinout<sup>[8]</sup>**



**Notes**

- The center pad on the QFN package should be connected to digital ground (Vssd) for best mechanical, thermal, and electrical performance. If not connected to ground, it should be electrically floated and not connected to any other signal.
- PPins are Do Not Use (DNU) on devices without USB. The pin must be left floating.

Figure 2-3. 68-pin QFN Part Pinout<sup>[10]</sup>



**Notes**

- 9. Pins are Do Not Use (DNU) on devices without USB. The pin must be left floating.
- 10. The center pad on the QFN package should be connected to digital ground (Vssd) for best mechanical, thermal, and electrical performance. If not connected to ground, it should be electrically floated and not connected to any other signal.

**Figure 2-4. 100-pin TQFP Part Pinout**

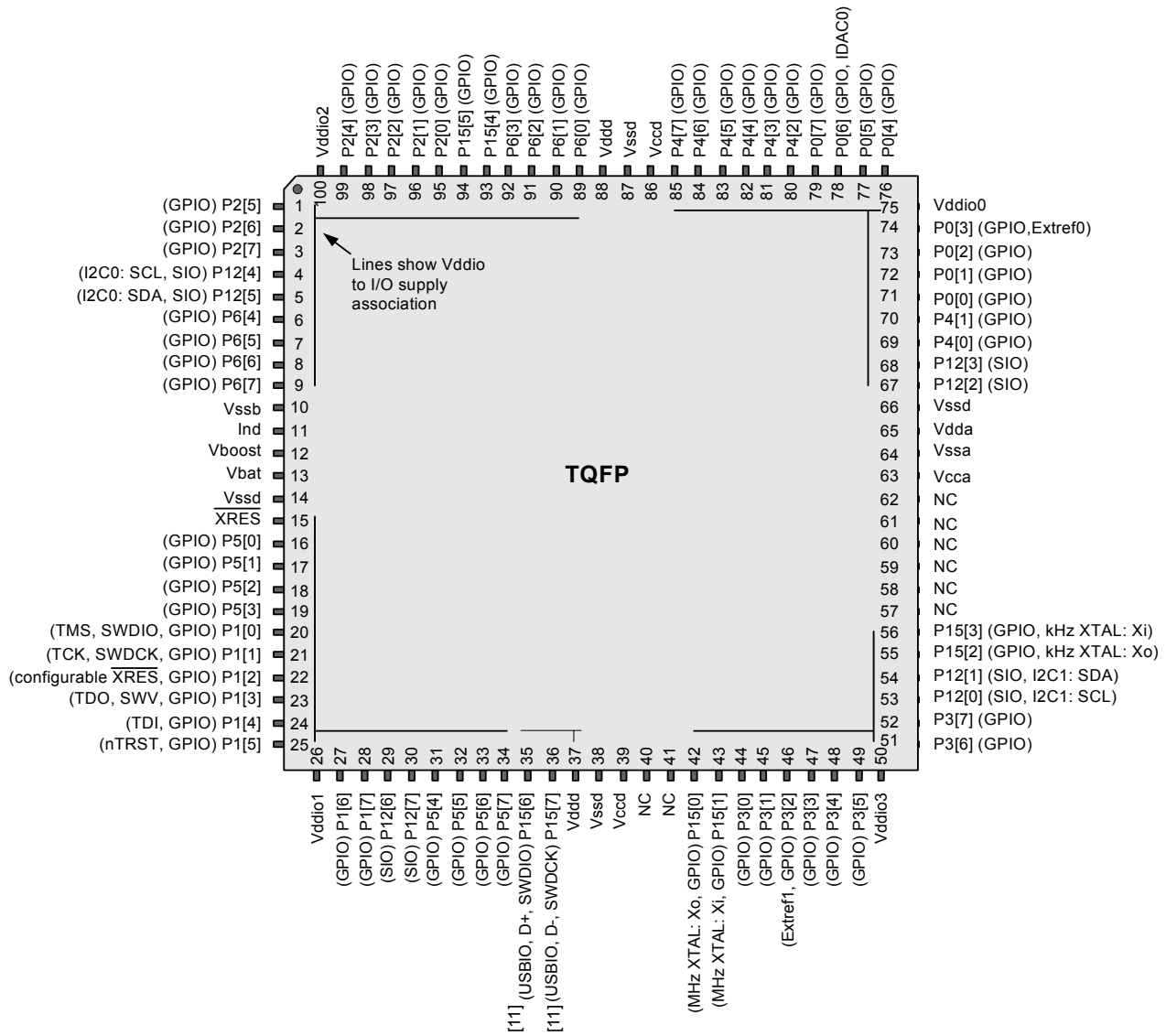


Figure 2-5 and Figure 2-6 show an example schematic and an example PCB layout, for the 100-pin TQFP part, for optimal analog performance on a two layer board.

- The two pins labeled Vdd must be connected together.
- The two pins labeled Vcc must be connected together, with capacitance added, as shown in Figure 2-5 and Power System on page 29. The trace between the two Vcc pins should be as short as possible.
- The two pins labeled Vss must be connected together.

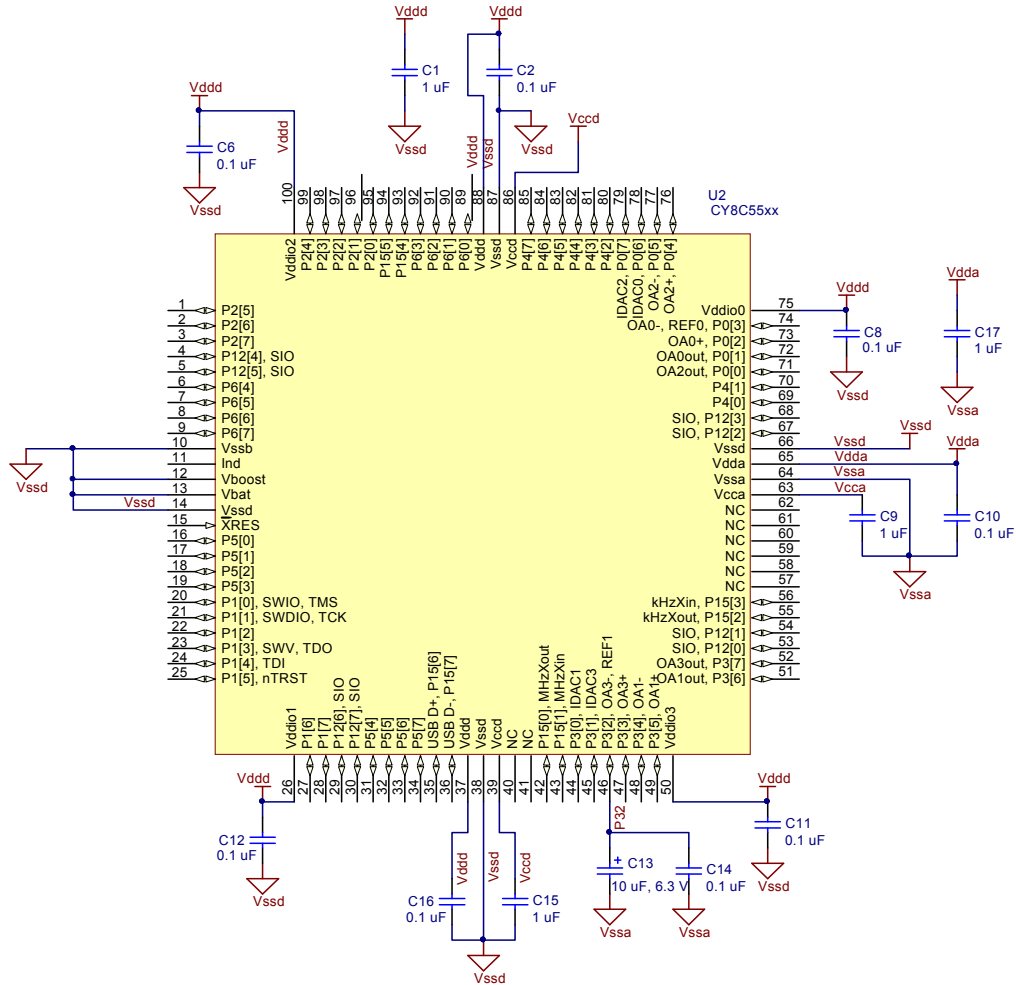
For information on circuit board layout issues for mixed signals, refer to the application note [AN57821 - Mixed Signal Circuit Board Layout Considerations for PSoC® 3 and PSoC 5](#).

**Note**

11. Pins are Do Not Use (DNU) on devices without USB. The pin must be left floating.

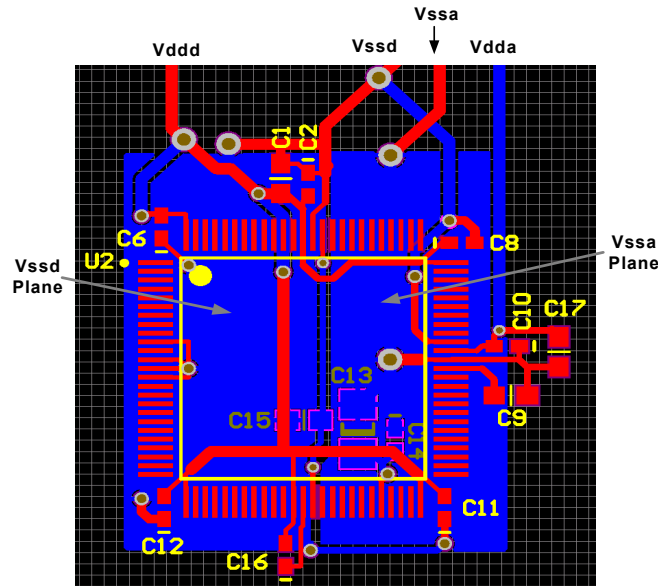


Figure 2-5. Example Schematic for 100-pin TQFP Part with Power Connections



**Note** The two Vccd pins must be connected together with as short a trace as possible. A trace under the device is recommended, as shown in [Figure 2-6](#) on page 10.

Figure 2-6. Example PCB Layout for 100-pin TQFP Part for Optimal Analog Performance



### 3. Pin Descriptions

#### IDAC0

Low resistance output pin for high current DAC (IDAC).

#### Extref0, Extref1

External reference input to the analog system.

#### GPIO

General purpose I/O pin provides interfaces to the CPU, digital peripherals, analog peripherals, interrupts, LCD segment drive, and CapSense.

#### I2C0: SCL, I2C1: SCL

I<sup>2</sup>C SCL line providing wake from sleep on an address match. Any I/O pin can be used for I<sup>2</sup>C SCL if wake from sleep is not required.

#### I2C0: SDA, I2C1: SDA

I<sup>2</sup>C SDA line providing wake from sleep on an address match. Any I/O pin can be used for I<sup>2</sup>C SDA if wake from sleep is not required.

#### Ind

Inductor connection to boost pump.

#### kHz XTAL: Xo, kHz XTAL: Xi

32.768-kHz crystal oscillator pin.

#### MHz XTAL: Xo, MHz XTAL: Xi

4- to 25- MHz crystal oscillator pin.

#### nTRST

Optional JTAG test reset programming and debug port connection to reset the JTAG connection.

#### SIO

Special I/O provides interfaces to the CPU, digital peripherals and interrupts with a programmable high threshold voltage, analog comparator, high sink current, and high impedance state when the device is unpowered.

#### SWDCK

Serial wire debug clock programming and debug port connection.

#### SWDIO

Serial wire debug input and output programming and debug port connection.

#### SWV.

Single wire viewer debug output.

#### TCK

JTAG test clock programming and debug port connection.

#### TDI

JTAG test data in programming and debug port connection.

#### TDO

JTAG test data out programming and debug port connection.

#### TMS

JTAG test mode select programming and debug port connection.

#### USBIO, D+

Provides D+ connection directly to a USB 2.0 bus. May be used as a digital I/O pin. Pins are Do Not Use (DNU) on devices without USB.

#### USBIO, D-

Provides D- connection directly to a USB 2.0 bus. May be used as a digital I/O pin. Pins are No Connect (NC) on devices without USB.

#### Vboost

Power sense connection to boost pump.

#### Vbat

Battery supply to boost pump.

#### Vcca

Output of analog core regulator and input to analog core. Requires a 1- $\mu$ F capacitor to  $V_{SSA}$ . Regulator output not for external use.

#### Vccd

Output of digital core regulator and input to digital core. The two  $V_{CCD}$  pins must be shorted together, with the trace between them as short as possible, and a 1- $\mu$ F capacitor to  $V_{SSD}$ ; see [Power System](#) on page 29. Regulator output not for external use.

#### Vdda

Supply for all analog peripherals and analog core regulator. **Vdda must be the highest voltage present on the device. All other supply pins must be less than or equal to  $V_{DDA}$ .**

#### Vddd

Supply for all digital peripherals and digital core regulator.  $V_{DDA}$  must be less than or equal to  $V_{DDA}$ .

#### Vssa

Ground for all analog peripherals.

#### Vssb

Ground connection for boost pump.

#### Vssd

Ground for all digital logic and I/O pins.

#### Vddio0, Vddio1, Vddio2, Vddio3

Supply for I/O pins. See pinouts for specific I/O pin to Vddio mapping. Each Vddio must be tied to a valid operating voltage (1.71 V to 5.5 V), and must be less than or equal to Vdda. If the I/O pins associated with Vddio0, Vddio2 or Vddio3 are not used then that Vddio should be tied to ground ( $V_{SSD}$  or  $V_{SSA}$ ).

#### XRES (and configurable XRES)

External reset pin. Active low with internal pull-up. Pin P1[2] may be configured to be a XRES pin; see [“Nonvolatile Latches \(NVLS\)”](#) on page 23.

## 4. CPU

### 4.1 8051 CPU

The CY8C32 devices use a single cycle 8051 CPU, which is fully compatible with the original MCS-51 instruction set. The CY8C32 family uses a pipelined RISC architecture, which executes most instructions in 1 to 2 cycles to provide peak performance of up to 24 MIPS with an average of 2 cycles per instruction. The single cycle 8051 CPU runs ten times faster than a standard 8051 processor.

The 8051 CPU subsystem includes these features:

- Single cycle 8051 CPU
- Up to 64 KB of flash memory, up to 2 KB of EEPROM, and up to 8 KB of SRAM
- Programmable nested vector interrupt controller
- Direct memory access (DMA) controller
- Peripheral HUB (PHUB)
- External memory interface (EMIF)

### 4.2 Addressing Modes

The following addressing modes are supported by the 8051:

- Direct Addressing: The operand is specified by a direct 8-bit address field. Only the internal RAM and the SFRs can be accessed using this mode.
- Indirect Addressing: The instruction specifies the register which contains the address of the operand. The registers R0 or R1 are used to specify the 8-bit address, while the data pointer (DPTR) register is used to specify the 16-bit address.
- Register Addressing: Certain instructions access one of the registers (R0 to R7) in the specified register bank. These instructions are more efficient because there is no need for an address field.
- Register Specific Instructions: Some instructions are specific to certain registers. For example, some instructions always act on the accumulator. In this case, there is no need to specify the operand.
- Immediate Constants: Some instructions carry the value of the constants directly instead of an address.
- Indexed Addressing: This type of addressing can be used only for a read of the program memory. This mode uses the data pointer as the base and the accumulator value as an offset to read a program memory.
- Bit Addressing: In this mode, the operand is one of 256 bits.

### 4.3 Instruction Set

The 8051 instruction set is highly optimized for 8-bit handling and Boolean operations. The types of instructions supported include:

- Arithmetic instructions
- Logical instructions
- Data transfer instructions
- Boolean instructions
- Program branching instructions

#### 4.3.1 Instruction Set Summary

##### 4.3.1.1 Arithmetic Instructions

Arithmetic instructions support the direct, indirect, register, immediate constant, and register-specific instructions. Arithmetic modes are used for addition, subtraction, multiplication, division, increment, and decrement operations. [Table 4-1 Table 4-1](#) on page 12 lists the different arithmetic instructions.

**Table 4-1. Arithmetic Instructions**

Mnemonic	Description	Bytes	Cycles
ADD A,Rn	Add register to accumulator	1	1
ADD A,Direct	Add direct byte to accumulator	2	2
ADD A,@Ri	Add indirect RAM to accumulator	1	2
ADD A,#data	Add immediate data to accumulator	2	2
ADDC A,Rn	Add register to accumulator with carry	1	1
ADDC A,Direct	Add direct byte to accumulator with carry	2	2
ADDC A,@Ri	Add indirect RAM to accumulator with carry	1	2
ADDC A,#data	Add immediate data to accumulator with carry	2	2
SUBB A,Rn	Subtract register from accumulator with borrow	1	1
SUBB A,Direct	Subtract direct byte from accumulator with borrow	2	2
SUBB A,@Ri	Subtract indirect RAM from accumulator with borrow	1	2
SUBB A,#data	Subtract immediate data from accumulator with borrow	2	2
INC A	Increment accumulator	1	1
INC Rn	Increment register	1	2
INC Direct	Increment direct byte	2	3
INC @Ri	Increment indirect RAM	1	3
DEC A	Decrement accumulator	1	1
DEC Rn	Decrement register	1	2
DEC Direct	Decrement direct byte	2	3
DEC @Ri	Decrement indirect RAM	1	3
INC DPTR	Increment data pointer	1	1
MUL	Multiply accumulator and B	1	2
DIV	Divide accumulator by B	1	6
DAA	Decimal adjust accumulator	1	3

#### 4.3.1.2 Logical Instructions

The logical instructions perform Boolean operations such as AND, OR, XOR on bytes, rotate of accumulator contents, and swap of nibbles in an accumulator. The Boolean operations on the bytes are performed on the bit-by-bit basis. [Table 4-2](#) on page 13 shows the list of logical instructions and their description.

**Table 4-2. Logical Instructions**

Mnemonic	Description	Bytes	Cycles
ANL A,Rn	AND register to accumulator	1	1
ANL A,Direct	AND direct byte to accumulator	2	2
ANL A,@Ri	AND indirect RAM to accumulator	1	2
ANL A,#data	AND immediate data to accumulator	2	2
ANL Direct, A	AND accumulator to direct byte	2	3
ANL Direct, #data	AND immediate data to direct byte	3	3
ORL A,Rn	OR register to accumulator	1	1
ORL A,Direct	OR direct byte to accumulator	2	2
ORL A,@Ri	OR indirect RAM to accumulator	1	2
ORL A,#data	OR immediate data to accumulator	2	2
ORL Direct, A	OR accumulator to direct byte	2	3
ORL Direct, #data	OR immediate data to direct byte	3	3
XRL A,Rn	XOR register to accumulator	1	1
XRL A,Direct	XOR direct byte to accumulator	2	2
XRL A,@Ri	XOR indirect RAM to accumulator	1	2
XRL A,#data	XOR immediate data to accumulator	2	2
XRL Direct, A	XOR accumulator to direct byte	2	3
XRL Direct, #data	XOR immediate data to direct byte	3	3
CLR A	Clear accumulator	1	1
CPL A	Complement accumulator	1	1
RL A	Rotate accumulator left	1	1
RLC A	Rotate accumulator left through carry	1	1
RR A	Rotate accumulator right	1	1
RRC A	Rotate accumulator right though carry	1	1
SWAP A	Swap nibbles within accumulator	1	1

#### 4.3.1.3 Data Transfer Instructions

The data transfer instructions are of three types: the core RAM, xdata RAM, and the lookup tables. The core RAM transfer includes transfer between any two core RAM locations or SFRs. These instructions can use direct, indirect, register, and immediate addressing. The xdata RAM transfer includes only the transfer between the accumulator and the xdata RAM location. It can use only indirect addressing. The lookup tables involve nothing but the read of program memory using the Indexed

addressing mode. [Table 4-3](#) lists the various data transfer instructions available.

#### 4.3.1.4 Boolean Instructions

The 8051 core has a separate bit-addressable memory location. It has 128 bits of bit addressable RAM and a set of SFRs that are bit addressable. The instruction set includes the whole menu of bit operations such as move, set, clear, toggle, OR, and AND instructions and the conditional jump instructions. [Table 4-4](#) on page 15 [Table 4-4](#) lists the available Boolean instructions.

**Table 4-3. Data Transfer Instructions**

Mnemonic	Description	Bytes	Cycles
MOV A,Rn	Move register to accumulator	1	1
MOV A,Direct	Move direct byte to accumulator	2	2
MOV A,@Ri	Move indirect RAM to accumulator	1	2
MOV A,#data	Move immediate data to accumulator	2	2
MOV Rn,A	Move accumulator to register	1	1
MOV Rn,Direct	Move direct byte to register	2	3
MOV Rn,#data	Move immediate data to register	2	2
MOV Direct,A	Move accumulator to direct byte	2	2
MOV Direct,Rn	Move register to direct byte	2	2
MOV Direct,Direct	Move direct byte to direct byte	3	3
MOV Direct,@Ri	Move indirect RAM to direct byte	2	3
MOV Direct,#data	Move immediate data to direct byte	3	3
MOV @Ri,A	Move accumulator to indirect RAM	1	2
MOV @Ri,Direct	Move direct byte to indirect RAM	2	3
MOV @Ri,#data	Move immediate data to indirect RAM	2	2
MOV DPTR,#data16	Load data pointer with 16-bit constant	3	3
MOVC A,@A+DPTR	Move code byte relative to DPTR to accumulator	1	5
MOVC A,@A+PC	Move code byte relative to PC to accumulator	1	4
MOVX A,@Ri	Move external RAM (8-bit) to accumulator	1	4
MOVX A,@DPTR	Move external RAM (16-bit) to accumulator	1	3
MOVX @Ri,A	Move accumulator to external RAM (8-bit)	1	5
MOVX @DPTR,A	Move accumulator to external RAM (16-bit)	1	4
PUSH Direct	Push direct byte onto stack	2	3
POP Direct	Pop direct byte from stack	2	2
XCH A,Rn	Exchange register with accumulator	1	2
XCH A,Direct	Exchange direct byte with accumulator	2	3
XCH A,@Ri	Exchange indirect RAM with accumulator	1	3
XCHD A,@Ri	Exchange low order indirect digit RAM with accumulator	1	3

**Table 4-4. Boolean Instructions**

Mnemonic	Description	Bytes	Cycles
CLR C	Clear carry	1	1
CLR bit	Clear direct bit	2	3
SETB C	Set carry	1	1
SETB bit	Set direct bit	2	3
CPL C	Complement carry	1	1
CPL bit	Complement direct bit	2	3
ANL C, bit	AND direct bit to carry	2	2
ANL C, /bit	AND complement of direct bit to carry	2	2
ORL C, bit	OR direct bit to carry	2	2
ORL C, /bit	OR complement of direct bit to carry	2	2
MOV C, bit	Move direct bit to carry	2	2
MOV bit, C	Move carry to direct bit	2	3
JC rel	Jump if carry is set	2	3
JNC rel	Jump if no carry is set	2	3
JB bit, rel	Jump if direct bit is set	3	5
JNB bit, rel	Jump if direct bit is not set	3	5
JBC bit, rel	Jump if direct bit is set and clear bit	3	5

#### 4.3.1.5 Program Branching Instructions

The 8051 supports a set of conditional and unconditional jump instructions that help to modify the program execution flow. Table 4-5 shows the list of jump instructions.

**Table 4-5. Jump Instructions**

Mnemonic	Description	Bytes	Cycles
ACALL addr11	Absolute subroutine call	2	4
LCALL addr16	Long subroutine call	3	4
RET	Return from subroutine	1	4
RETI	Return from interrupt	1	4
AJMP addr11	Absolute jump	2	3
LJMP addr16	Long jump	3	4
SJMP rel	Short jump (relative address)	2	3
JMP @A + DPTR	Jump indirect relative to DPTR	1	5
JZ rel	Jump if accumulator is zero	2	4
JNZ rel	Jump if accumulator is nonzero	2	4
CJNE A,Direct, rel	Compare direct byte to accumulator and jump if not equal	3	5
CJNE A, #data, rel	Compare immediate data to accumulator and jump if not equal	3	4
CJNE Rn, #data, rel	Compare immediate data to register and jump if not equal	3	4
CJNE @Ri, #data, rel	Compare immediate data to indirect RAM and jump if not equal	3	5
DJNZ Rn,rel	Decrement register and jump if not zero	2	4
DJNZ Direct, rel	Decrement direct byte and jump if not zero	3	5
NOP	No operation	1	1

#### 4.4 DMA and PHUB

The PHUB and the DMA controller are responsible for data transfer between the CPU and peripherals, and also data transfers between peripherals. The PHUB and DMA also control device configuration during boot. The PHUB consists of:

- A central hub that includes the DMA controller, arbiter, and router
- Multiple spokes that radiate outward from the hub to most peripherals

There are two PHUB masters: the CPU and the DMA controller. Both masters may initiate transactions on the bus. The DMA channels can handle peripheral communication without CPU intervention. The arbiter in the central hub determines which DMA channel is the highest priority if there are multiple requests.

##### 4.4.1 PHUB Features

- CPU and DMA controller are both bus masters to the PHUB
- Eight Multi-layer AHB Bus parallel access paths (spokes) for peripheral access

- Simultaneous CPU and DMA access to peripherals located on different spokes
- Simultaneous DMA source and destination burst transactions on different spokes
- Supports 8, 16, 24, and 32-bit addressing and data

**Table 4-6. PHUB Spokes and Peripherals**

PHUB Spokes	Peripherals
0	SRAM
1	IOs, PICU, EMIF
2	PHUB local configuration, Power manager, Clocks, IC, SWV, EEPROM, Flash programming interface
3	Analog interface and trim, Decimator
4	USB, USB, I <sup>2</sup> C, Timers, Counters, and PWMs
5	Reserved
6	UDBs group 1
7	UDBs group 2



#### 4.4.2 DMA Features

- 24 DMA channels
- Each channel has one or more transaction descriptors (TDs) to configure channel behavior. Up to 128 total TDs can be defined
- TDs can be dynamically updated
- Eight levels of priority per channel
- Any digitally routable signal, the CPU, or another DMA channel, can trigger a transaction
- Each channel can generate up to two interrupts per transfer
- Transactions can be stalled or canceled
- Supports transaction size of infinite or 1 to 64k bytes
- TDs may be nested and/or chained for complex transactions

#### 4.4.3 Priority Levels

The CPU always has higher priority than the DMA controller when their accesses require the same bus resources. Due to the system architecture, the CPU can never starve the DMA. DMA channels of higher priority (lower priority number) may interrupt current DMA transfers. In the case of an interrupt, the current transfer is allowed to complete its current transaction. To ensure latency limits when multiple DMA accesses are requested simultaneously, a fairness algorithm guarantees an interleaved minimum percentage of bus bandwidth for priority levels 2 through 7. Priority levels 0 and 1 do not take part in the fairness algorithm and may use 100 percent of the bus bandwidth. If a tie occurs on two DMA requests of the same priority level, a simple round robin method is used to evenly share the allocated bandwidth. The round robin allocation can be disabled for each DMA channel, allowing it to always be at the head of the line. Priority levels 2 to 7 are guaranteed the minimum bus bandwidth

shown in [Table 4-7](#) after the CPU and DMA priority levels 0 and 1 have satisfied their requirements.

**Table 4-7. Priority Levels**

Priority Level	% Bus Bandwidth
0	100.0
1	100.0
2	50.0
3	25.0
4	12.5
5	6.2
6	3.1
7	1.5

When the fairness algorithm is disabled, DMA access is granted based solely on the priority level; no bus bandwidth guarantees are made.

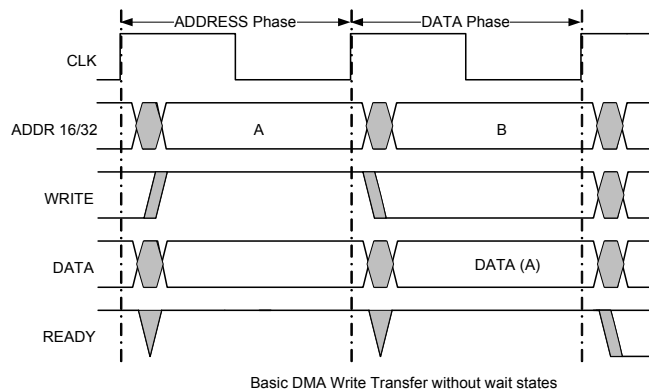
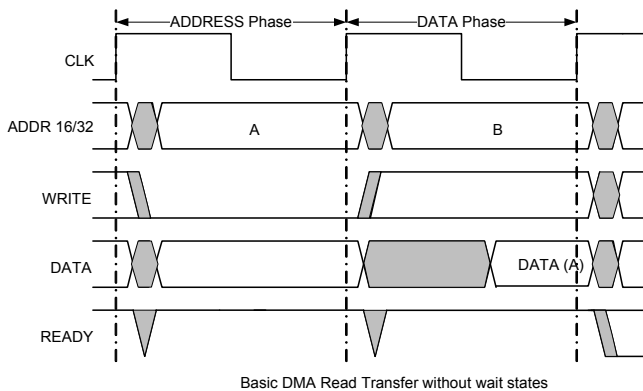
#### 4.4.4 Transaction Modes Supported

The flexible configuration of each DMA channel and the ability to chain multiple channels allow the creation of both simple and complex use cases. General use cases include, but are not limited to:

##### 4.4.4.1 Simple DMA

In a simple DMA case, a single TD transfers data between a source and sink (peripherals or memory location). The basic timing diagrams of DMA read and write cycles are shown in [Figure 4-1](#). For more description on other transfer modes, refer to the Technical Reference Manual.

**Figure 4-1. DMA Timing Diagram**



##### 4.4.4.2 Auto Repeat DMA

Auto repeat DMA is typically used when a static pattern is repetitively read from system memory and written to a peripheral. This is done with a single TD that chains to itself.

##### 4.4.4.3 Ping Pong DMA

A ping pong DMA case uses double buffering to allow one buffer to be filled by one client while another client is consuming the

data previously received in the other buffer. In its simplest form, this is done by chaining two TDs together so that each TD calls the opposite TD when complete.

##### 4.4.4.4 Circular DMA

Circular DMA is similar to ping pong DMA except it contains more than two buffers. In this case there are multiple TDs; after the last TD is complete it chains back to the first TD.

#### 4.4.4.5 Scatter Gather DMA

In the case of scatter gather DMA, there are multiple noncontiguous sources or destinations that are required to effectively carry out an overall DMA transaction. For example, a packet may need to be transmitted off of the device and the packet elements, including the header, payload, and trailer, exist in various noncontiguous locations in memory. Scatter gather DMA allows the segments to be concatenated together by using multiple TDs in a chain. The chain gathers the data from the multiple locations. A similar concept applies for the reception of data onto the device. Certain parts of the received data may need to be scattered to various locations in memory for software processing convenience. Each TD in the chain specifies the location for each discrete element in the chain.

#### 4.4.4.6 Packet Queuing DMA

Packet queuing DMA is similar to scatter gather DMA but specifically refers to packet protocols. With these protocols, there may be separate configuration, data, and status phases associated with sending or receiving a packet.

For instance, to transmit a packet, a memory mapped configuration register can be written inside a peripheral, specifying the overall length of the ensuing data phase. The CPU can set up this configuration information anywhere in system memory and copy it with a simple TD to the peripheral. After the configuration phase, a data phase TD (or a series of data phase TDs) can begin (potentially using scatter gather). When the data phase TD(s) finish, a status phase TD can be invoked that reads some memory mapped status information from the peripheral and copies it to a location in system memory specified by the CPU for later inspection. Multiple sets of configuration, data, and status phase “subchains” can be strung together to create larger chains that transmit multiple packets in this way. A similar concept exists in the opposite direction to receive the packets.

#### 4.4.4.7 Nested DMA

One TD may modify another TD, as the TD configuration space is memory mapped similar to any other peripheral. For example, a first TD loads a second TD's configuration and then calls the second TD. The second TD moves data as required by the application. When complete, the second TD calls the first TD, which again updates the second TD's configuration. This process repeats as often as necessary.

## 4.5 Interrupt Controller

The interrupt controller provides a mechanism for hardware resources to change program execution to a new address, independent of the current task being executed by the main code. The interrupt controller provides enhanced features not found on original 8051 interrupt controllers:

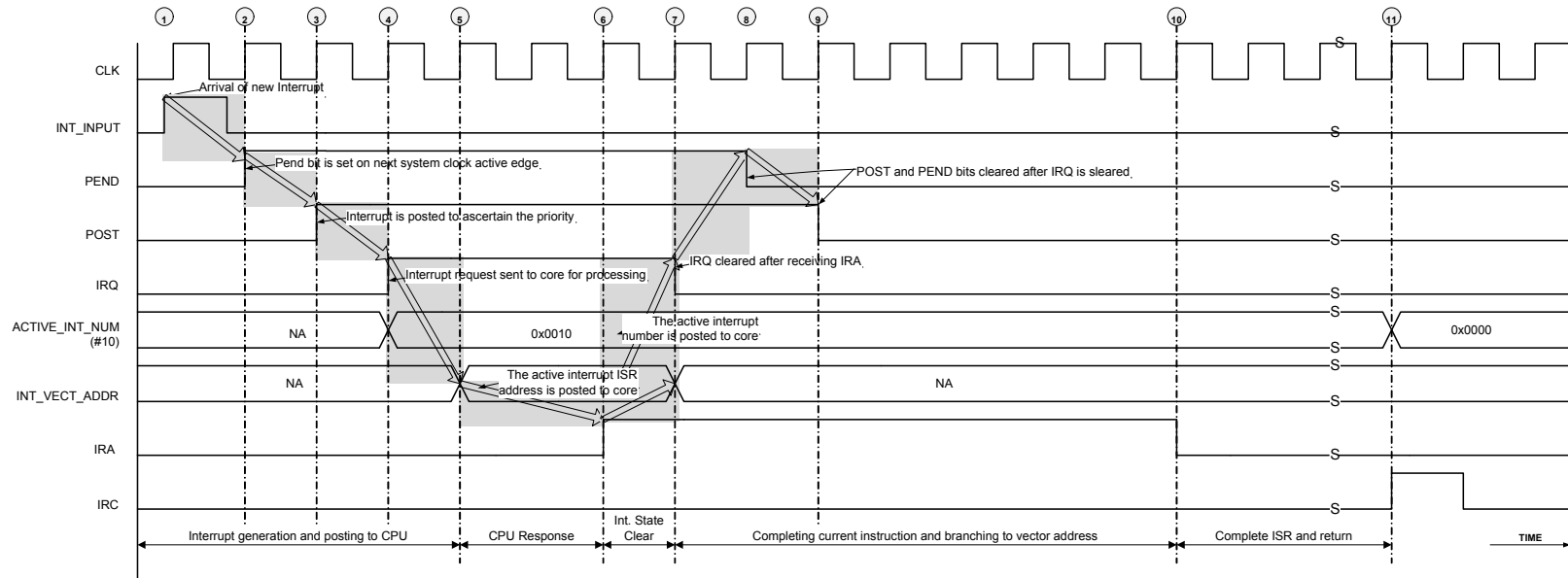
- Thirty two interrupt vectors
- Jumps directly to ISR anywhere in code space with dynamic vector addresses
- Multiple sources for each vector
- Flexible interrupt to vector matching
- Each interrupt vector is independently enabled or disabled
- Each interrupt can be dynamically assigned one of eight priorities
- Eight level nestable interrupts
- Multiple I/O interrupt vectors
- Software can send interrupts
- Software can clear pending interrupts

When an interrupt is pending, the current instruction is completed and the program counter is pushed onto the stack. Code execution then jumps to the program address provided by the vector. After the ISR is completed, a RETI instruction is executed and returns execution to the instruction following the previously interrupted instruction. To do this the RETI instruction pops the program counter from the stack.

If the same priority level is assigned to two or more interrupts, the interrupt with the lower vector number is executed first. Each interrupt vector may choose from three interrupt sources: Fixed Function, DMA, and UDB. The fixed function interrupts are direct connections to the most common interrupt sources and provide the lowest resource cost connection. The DMA interrupt sources provide direct connections to the two DMA interrupt sources provided per DMA channel. The third interrupt source for vectors is from the UDB digital routing array. This allows any digital signal available to the UDB array to be used as an interrupt source. Fixed function interrupts and all interrupt sources may be routed to any interrupt vector using the UDB interrupt source connections.

Figure 4-2 on page 19 represents typical flow of events when an interrupt triggered. Figure 4-3 on page 20 shows the interrupt structure and priority polling.

Figure 4-2. Interrupt Processing Timing Diagram

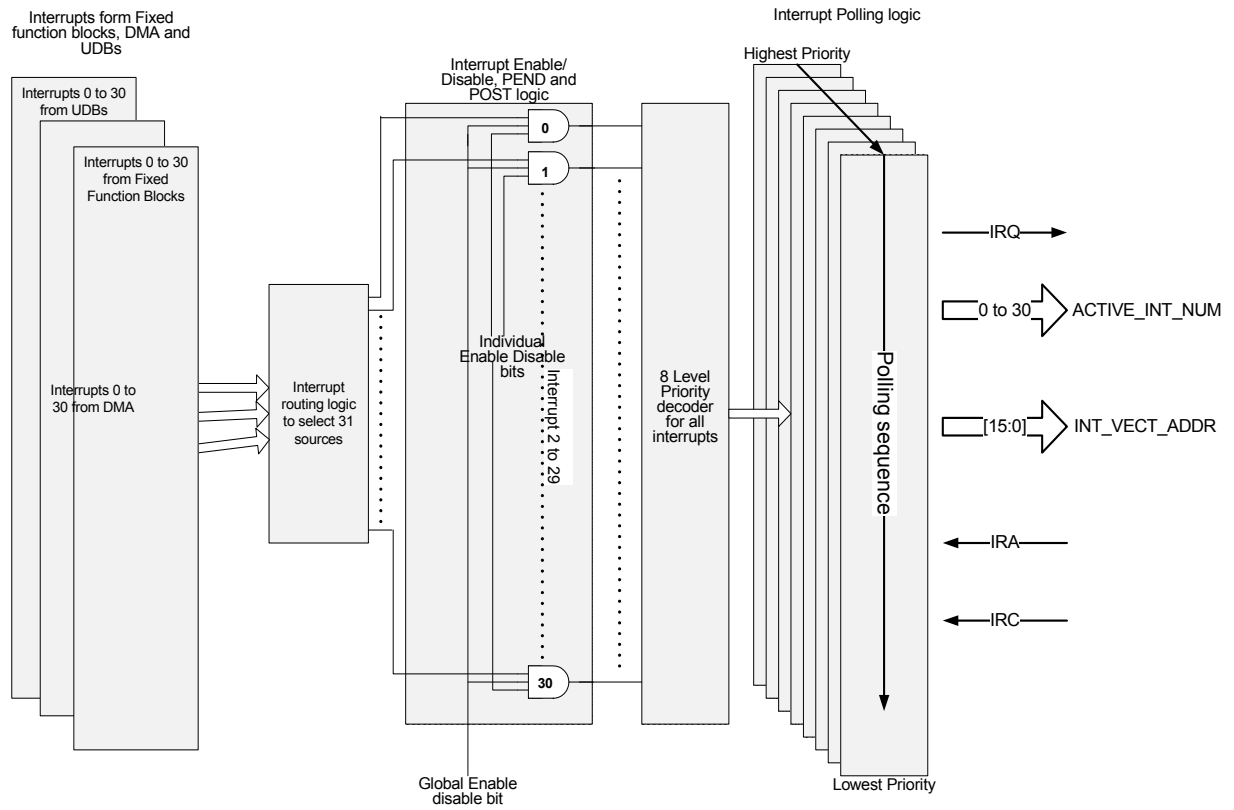


**Notes**

- 1: Interrupt triggered asynchronous to the clock
- 2: The PEND bit is set on next active clock edge to indicate the interrupt arrival
- 3: POST bit is set following the PEND bit
- 4: Interrupt request and the interrupt number sent to CPU core after evaluation priority (Takes 3 clocks)
- 5: ISR address is posted to CPU core for branching
- 6: CPU acknowledges the interrupt request
- 7: ISR address is read by CPU for branching
- 8, 9: PEND and POST bits are cleared respectively after receiving the IRA from core
- 10: IRA bit is cleared after completing the current instruction and starting the instruction execution from ISR location (Takes 7 cycles)
- 11: IRC is set to indicate the completion of ISR, Active int. status is restored with previous status

The total interrupt latency (ISR execution)  
 = POST + PEND + IRQ + IRA + Completing current instruction and branching  
 = 1+1+1+2+7 cycles  
 = 12 cycles

Figure 4-3. Interrupt Structure



**Table 4-8. Interrupt Vector Table**

#	Fixed Function	DMA	UDB
0	LVD	phub_termout0[0]	udb_intr[0]
1	ECC	phub_termout0[1]	udb_intr[1]
2	Reserved	phub_termout0[2]	udb_intr[2]
3	Sleep (Pwr Mgr)	phub_termout0[3]	udb_intr[3]
4	PICU[0]	phub_termout0[4]	udb_intr[4]
5	PICU[1]	phub_termout0[5]	udb_intr[5]
6	PICU[2]	phub_termout0[6]	udb_intr[6]
7	PICU[3]	phub_termout0[7]	udb_intr[7]
8	PICU[4]	phub_termout0[8]	udb_intr[8]
9	PICU[5]	phub_termout0[9]	udb_intr[9]
10	PICU[6]	phub_termout0[10]	udb_intr[10]
11	PICU[12]	phub_termout0[11]	udb_intr[11]
12	PICU[15]	phub_termout0[12]	udb_intr[12]
13	Comparators Combined	phub_termout0[13]	udb_intr[13]
14	Reserved	phub_termout0[14]	udb_intr[14]
15	I <sup>2</sup> C	phub_termout0[15]	udb_intr[15]
16	Reserved	phub_termout1[0]	udb_intr[16]
17	Timer/Counter0	phub_termout1[1]	udb_intr[17]
18	Timer/Counter1	phub_termout1[2]	udb_intr[18]
19	Timer/Counter2	phub_termout1[3]	udb_intr[19]
20	Timer/Counter3	phub_termout1[4]	udb_intr[20]
21	USB SOF Int	phub_termout1[5]	udb_intr[21]
22	USB Arb Int	phub_termout1[6]	udb_intr[22]
23	USB Bus Int	phub_termout1[7]	udb_intr[23]
24	USB Endpoint[0]	phub_termout1[8]	udb_intr[24]
25	USB Endpoint Data	phub_termout1[9]	udb_intr[25]
26	Reserved	phub_termout1[10]	udb_intr[26]
27	LCD	phub_termout1[11]	udb_intr[27]
28	Reserved	phub_termout1[12]	udb_intr[28]
29	Decimator Int	phub_termout1[13]	udb_intr[29]
30	PHUB Error Int	phub_termout1[14]	udb_intr[30]
31	EEPROM Fault Int	phub_termout1[15]	udb_intr[31]

## 5. Memory

### 5.1 Static RAM

CY8C32 Static RAM (SRAM) is used for temporary data storage. Up to 8 KB of SRAM is provided and can be accessed by the 8051 or the DMA controller. See [Memory Map](#) on page 24. Simultaneous access of SRAM by the 8051 and the DMA controller is possible if different 4-KB blocks are accessed.

### 5.2 Flash Program Memory

Flash memory in PSoC devices provides nonvolatile storage for user firmware, user configuration data, bulk data storage, and optional ECC data. The main flash memory area contains up to 64 KB of user program space.

Up to an additional 8 KB of flash space is available for Error Correcting Codes (ECC). If ECC is not used this space can store device configuration data and bulk user data. User code may not be run out of the ECC flash memory section. ECC can correct one bit error and detect two bit errors per 8 bytes of firmware memory; an interrupt can be generated when an error is detected.

Flash is read in units of rows; each row is 9 bytes wide with 8 bytes of data and 1 byte of ECC data. When a row is read, the data bytes are copied into an 8-byte instruction buffer. The CPU fetches its instructions from this buffer, for improved CPU performance.

Flash programming is performed through a special interface and preempts code execution out of flash. The flash programming interface performs flash erasing, programming and setting code protection levels. Flash in-system serial programming (ISSP), typically used for production programming, is possible through both the SWD and JTAG interfaces. In-system programming, typically used for bootloaders, is also possible using serial interfaces such as I<sup>2</sup>C, USB, UART, and SPI, or any communications protocol.

### 5.3 Flash Security

All PSoC devices include a flexible flash-protection model that prevents access and visibility to on-chip flash memory. This prevents duplication or reverse engineering of proprietary code. Flash memory is organized in blocks, where each block contains 256 bytes of program or data and 32 bytes of ECC or configuration data. A total of up to 256 blocks is provided on 64-KB flash devices.

The device offers the ability to assign one of four protection levels to each row of flash. [Table 5-1](#) lists the protection modes available. Flash protection levels can only be changed by performing a complete flash erase. The Full Protection and Field Upgrade settings disable external access (through a debugging tool such as PSoC Creator, for example). If your application requires code update through a boot loader, then use the Field Upgrade setting. Use the Unprotected setting only when no

security is needed in your application. The PSoC device also offers an advanced security feature called Device Security which permanently disables all test, programming, and debug ports, protecting your application from external access (see the [“Device Security”](#) section on page 62). For more information about how to take full advantage of the security features in PSoC, see the PSoC 3 TRM.

**Table 5-1. Flash Protection**

Protection Setting	Allowed	Not Allowed
Unprotected	External read and write + internal read and write	–
Factory Upgrade	External write + internal read and write	External read
Field Upgrade	Internal read and write	External read and write
Full Protection	Internal read	External read and write + internal write

#### Disclaimer

Note the following details of the flash code protection features on Cypress devices.

Cypress products meet the specifications contained in their particular Cypress datasheets. Cypress believes that its family of products is one of the most secure families of its kind on the market today, regardless of how they are used. There may be methods, unknown to Cypress, that can breach the code protection features. Any of these methods, to our knowledge, would be dishonest and possibly illegal. Neither Cypress nor any other semiconductor manufacturer can guarantee the security of their code. Code protection does not mean that we are guaranteeing the product as “unbreakable.”

Cypress is willing to work with the customer who is concerned about the integrity of their code. Code protection is constantly evolving. We at Cypress are committed to continuously improving the code protection features of our products.

### 5.4 EEPROM

PSoC EEPROM memory is a byte-addressable nonvolatile memory. The CY8C32 has up to 2 KB of EEPROM memory to store user data. Reads from EEPROM are random access at the byte level. Reads are done directly; writes are done by sending write commands to an EEPROM programming interface. CPU code execution can continue from flash during EEPROM writes. EEPROM is erasable and writeable at the row level. The EEPROM is divided into 128 rows of 16 bytes each.

The CPU can not execute out of EEPROM. There is no ECC hardware associated with EEPROM. If ECC is required it must be handled in firmware.

### 5.5 Nonvolatile Latches (NVLs)

PSoC has a 4-byte array of nonvolatile latches (NVLs) that are used to configure the device at reset. The NVL register map is shown in [Table 5-2](#).

**Table 5-2. Device Configuration NVL Register Map**

Register Address	7	6	5	4	3	2	1	0
0x00	PRT3RDM[1:0]		PRT2RDM[1:0]		PRT1RDM[1:0]		PRT0RDM[1:0]	
0x01	PRT12RDM[1:0]		PRT6RDM[1:0]		PRT5RDM[1:0]		PRT4RDM[1:0]	
0x02	XRESMEN						PRT15RDM[1:0]	
0x03	DIG_PHS_DLY[3:0]				ECCEN	DPS[1:0]		

The details for individual fields and their factory default settings are shown in [Table 5-3](#).

**Table 5-3. Fields and Factory Default Settings**

Field	Description	Settings
PRTxRDM[1:0]	Controls reset drive mode of the corresponding IO port. See <a href="#">“Reset Configuration”</a> on page 40. All pins of the port are set to the same mode.	00b (default) - high impedance analog 01b - high impedance digital 10b - resistive pull up 11b - resistive pull down
XRESMEN	Controls whether pin P1[2] is used as a GPIO or as an external reset. See <a href="#">“Pin Descriptions”</a> on page 10, XRES description.	0 (default for 68-pin and 100-pin parts) - GPIO 1 (default for 48-pin parts) - external reset
DPS{1:0}	Controls the usage of various P1 pins as a debug port. See <a href="#">“Programming, Debug Interfaces, Resources”</a> on page 59.	00b - 5-wire JTAG 01b (default) - 4-wire JTAG 10b - SWD 11b - debug ports disabled
ECCEN	Controls whether ECC flash is used for ECC or for general configuration and data storage. See <a href="#">“Flash Program Memory”</a> on page 22.	0 (default) - ECC disabled 1 - ECC enabled
DIG_PHS_DLY[3:0]	Selects the digital clock phase delay.	See the TRM for details.

Although PSoC Creator provides support for modifying the device configuration NVLs, the number of NVL erase / write cycles is limited – see [“Nonvolatile Latches \(NVL\)”](#) on page 97.

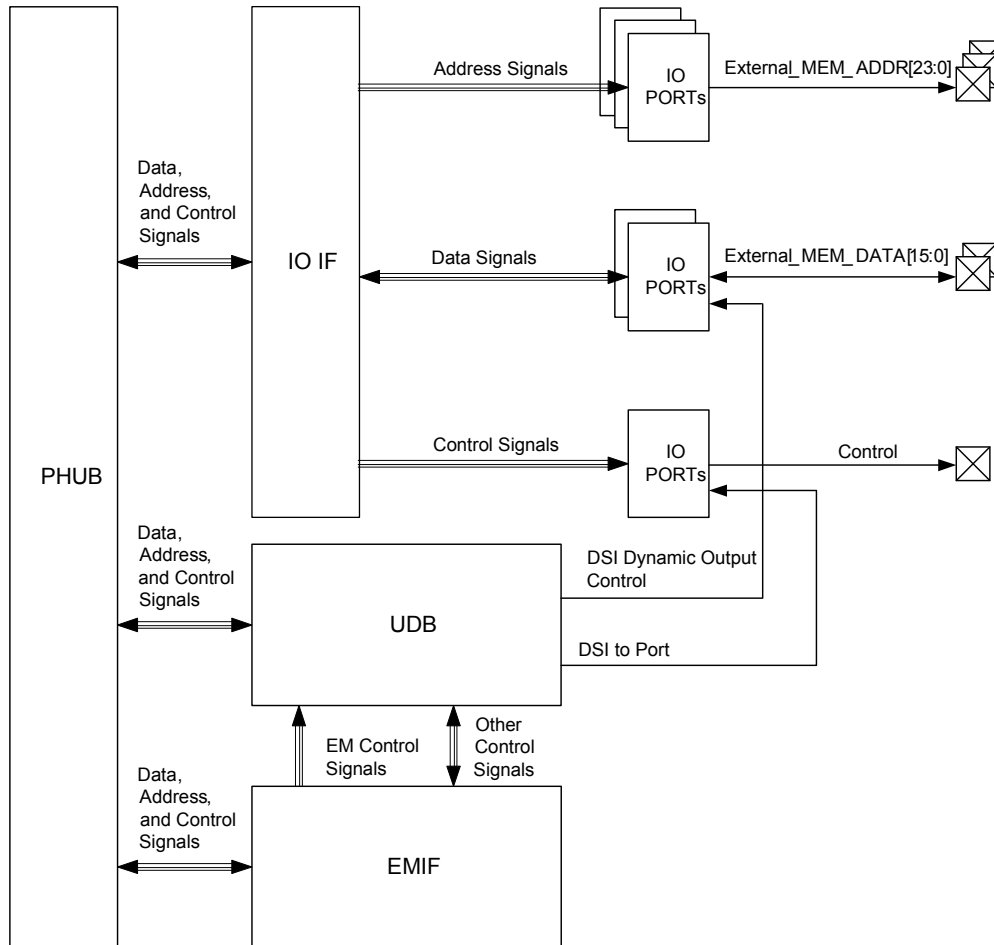
### 5.6 External Memory Interface

CY8C32 provides an external memory interface (EMIF) for connecting to external memory devices. The connection allows read and write accesses to external memories. The EMIF operates in conjunction with UDBs, I/O ports, and other hardware to generate external memory address and control signals. At 33 MHz, each memory access cycle takes four bus clock cycles.

Figure 5-1 is the EMIF block diagram. The EMIF supports synchronous and asynchronous memories. The CY8C32 supports only one type of external memory device at a time.

External memory can be accessed via the 8051 xdata space; up to 24 address bits can be used. See “xdata Space” section on page 26. The memory can be 8 or 16 bits wide.

Figure 5-1. EMIF Block Diagram



### 5.7 Memory Map

The CY8C32 8051 memory map is very similar to the MCS-51 memory map.

#### 5.7.1 Code Space

The CY8C32 8051 code space is 64 KB. Only main flash exists in this space. See the “Flash Program Memory” section on page 22.

#### 5.7.2 Internal Data Space

The CY8C32 8051 internal data space is 384 bytes, compressed within a 256-byte space. This space consists of 256 bytes of RAM (in addition to the SRAM mentioned in [Static RAM](#) on page 22) and a 128-byte space for Special Function Registers (SFRs). See [Figure 5-2](#). The lowest 32 bytes are used for 4 banks of registers R0-R7. The next 16 bytes are bit-addressable.



**Figure 5-2. 8051 Internal Data Space**

0x00 0x1F	4 Banks, R0-R7 Each	
0x20 0x2F	Bit-Addressable Area	
0x30 0x7F	Lower Core RAM Shared with Stack Space (direct and indirect addressing)	
0x80 0xFF	Upper Core RAM Shared with Stack Space (indirect addressing)	SFR Special Function Registers (direct addressing)

In addition to the register or bit address modes used with the lower 48 bytes, the lower 128 bytes can be accessed with direct or indirect addressing. With direct addressing mode, the upper 128 bytes map to the SFRs. With indirect addressing mode, the upper 128 bytes map to RAM. Stack operations use indirect addressing; the 8051 stack space is 256 bytes. See the “Addressing Modes” section on page 11

### 5.7.3 SFRs

The special function register (SFR) space provides access to frequently accessed registers. The memory map for the SFR memory space is shown in Table 5-4.

**Table 5-4. SFR Map**

Address	0/8	1/9	2/A	3/B	4/C	5/D	6/E	7/F
0xF8	SFRPRT15DR	SFRPRT15PS	SFRPRT15SEL	–	–	–	–	–
0xF0	B	–	SFRPRT12SEL	–	–	–	–	–
0xE8	SFRPRT12DR	SFRPRT12PS	MXAX	–	–	–	–	–
0xE0	ACC	–	–	–	–	–	–	–
0xD8	SFRPRT6DR	SFRPRT6PS	SFRPRT6SEL	–	–	–	–	–
0xD0	PSW	–	–	–	–	–	–	–
0xC8	SFRPRT5DR	SFRPRT5PS	SFRPRT5SEL	–	–	–	–	–
0xC0	SFRPRT4DR	SFRPRT4PS	SFRPRT4SEL	–	–	–	–	–
0xB8	–	–	–	–	–	–	–	–
0xB0	SFRPRT3DR	SFRPRT3PS	SFRPRT3SEL	–	–	–	–	–
0xA8	IE	–	–	–	–	–	–	–
0xA0	P2AX	–	SFRPRT1SEL	–	–	–	–	–
0x98	SFRPRT2DR	SFRPRT2PS	SFRPRT2SEL	–	–	–	–	–
0x90	SFRPRT1DR	SFRPRT1PS	–	DPX0	–	DPX1	–	–
0x88	–	SFRPRT0PS	SFRPRT0SEL	–	–	–	–	–
0x80	SFRPRT0DR	SP	DPL0	DPH0	DPL1	DPH1	DPS	–

The CY8C32 family provides the standard set of registers found on industry standard 8051 devices. In addition, the CY8C32 devices add SFRs to provide direct access to the I/O ports on the device. The following sections describe the SFRs added to the CY8C32 family.

### XData Space Access SFRs

The 8051 core features dual DPTR registers for faster data transfer operations. The data pointer select SFR, DPS, selects which data pointer register, DPTR0 or DPTR1, is used for the following instructions:

- MOVX @DPTR, A
- MOVX A, @DPTR
- MOVC A, @A+DPTR

- JMP @A+DPTR
- INC DPTR
- MOV DPTR, #data16

The extended data pointer SFRs, DPX0, DPX1, MXAX, and P2AX, hold the most significant parts of memory addresses during access to the xdata space. These SFRs are used only with the MOVX instructions.

During a MOVX instruction using the DPTR0/DPTR1 register, the most significant byte of the address is always equal to the contents of DPX0/DPX1.

During a MOVX instruction using the R0 or R1 register, the most significant byte of the address is always equal to the contents of MXAX, and the next most significant byte is always equal to the contents of P2AX.

**I/O Port SFRs**

The I/O ports provide digital input sensing, output drive, pin interrupts, connectivity for analog inputs and outputs, LCD, and access to peripherals through the DSI. Full information on I/O ports is found in [I/O System and Routing](#) on page 34.

I/O ports are linked to the CPU through the PHUB and are also available in the SFRs. Using the SFRs allows faster access to a limited set of I/O port registers, while using the PHUB allows boot configuration and access to all I/O port registers.

Each SFR supported I/O port provides three SFRs:

- SFRPRTxDR sets the output data state of the port (where x is port number and includes ports 0 – 6, 12 and 15).
- The SFRPRTxSEL selects whether the PHUB PRTxDR register or the SFRPRTxDR controls each pin’s output buffer within the port. If a SFRPRTxSEL[y] bit is high, the corresponding SFRPRTxDR[y] bit sets the output state for that pin. If a SFRPRTxSEL[y] bit is low, the corresponding PRTxDR[y] bit sets the output state of the pin (where y varies from 0 to 7).
- The SFRPRTxPS is a read only register that contains pin state values of the port pins.

**5.7.3.1 xdata Space**

The 8051 xdata space is 24-bit, or 16 MB in size. The majority of this space is not “external”—it is used by on-chip components. See [Table 5-5](#). External, that is, off-chip, memory can be accessed using the EMIF. See [External Memory Interface](#) on page 24.

**Table 5-5. XDATA Data Address Map**

Address Range	Purpose
0x00 0000 – 0x00 1FFF	SRAM
0x00 4000 – 0x00 42FF	Clocking, PLLs, and oscillators
0x00 4300 – 0x00 43FF	Power management
0x00 4400 – 0x00 44FF	Interrupt controller
0x00 4500 – 0x00 45FF	Ports interrupt control
0x00 4700 – 0x00 47FF	Flash programming interface
0x00 4900 – 0x00 49FF	I <sup>2</sup> C controller
0x00 4E00 – 0x00 4EFF	Decimator
0x00 4F00 – 0x00 4FFF	Fixed timer/counter/PWMs
0x00 5000 – 0x00 51FF	I/O ports control
0x00 5400 – 0x00 54FF	External Memory Interface (EMIF) control registers
0x00 5800 – 0x00 5FFF	Analog Subsystem interface
0x00 6000 – 0x00 60FF	USB controller
0x00 6400 – 0x00 6FFF	UDB configuration
0x00 7000 – 0x00 7FFF	PHUB configuration
0x00 8000 – 0x00 8FFF	EEPROM

**Table 5-5. XDATA Data Address Map (continued)**

Address Range	Purpose
0x01 0000 – 0x01 FFFF	Digital Interconnect configuration
0x05 0220 – 0x05 02F0	Debug controller
0x08 0000 – 0x08 1FFF	Flash ECC bytes
0x80 0000 – 0xFF FFFF	External Memory Interface

**6. System Integration**

**6.1 Clocking System**

The clocking system generates, divides, and distributes clocks throughout the PSoC system. For the majority of systems, no external crystal is required. The IMO and PLL together can generate up to a 50 MHz clock, accurate to ±1 percent over voltage and temperature. Additional internal and external clock sources allow each design to optimize accuracy, power, and cost. All of the system clock sources can be used to generate other clock frequencies in the 16-bit clock dividers and UDBs for anything the user wants, for example a UART baud rate generator.

Clock generation and distribution is automatically configured through the PSoC Creator IDE graphical interface. This is based on the complete system’s requirements. It greatly speeds the design process. PSoC Creator allows you to build clocking systems with minimal input. You can specify desired clock frequencies and accuracies, and the software locates or builds a clock that meets the required specifications. This is possible because of the programmability inherent PSoC.

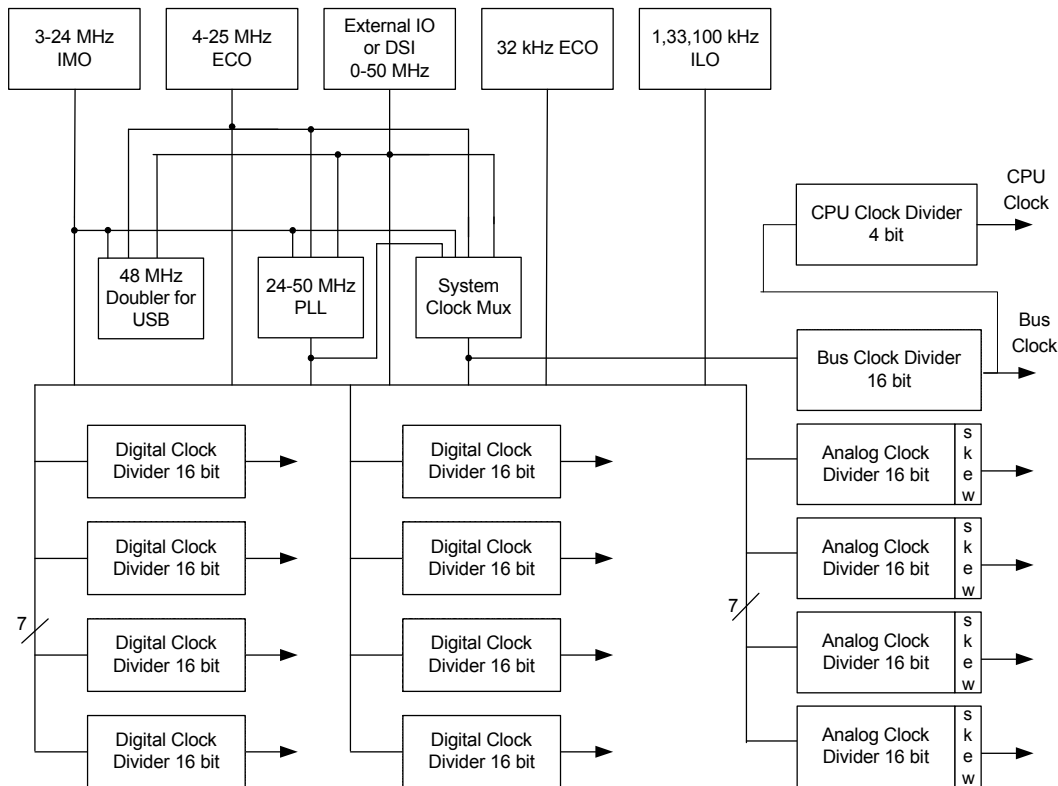
Key features of the clocking system include:

- Seven general purpose clock sources
  - 3- to 24-MHz IMO, ±1 percent at 3 MHz
  - 4- to 25-MHz external crystal oscillator (MHzECO)
  - Clock doubler provides a doubled clock frequency output for the USB block, see [USB Clock Domain](#) on page 29
  - DSI signal from an external I/O pin or other logic
  - 24- to 50- MHz fractional PLL sourced from IMO, MHzECO, or DSI
  - 1-kHz, 33-kHz, 100-kHz ILO for watchdog timer (WDT) and sleep timer
  - 32.768-kHz external crystal oscillator (kHzECO) for RTC
- IMO has a USB mode that auto locks to the USB bus clock requiring no external crystal for USB. (USB equipped parts only)
- Independently sourced clock in all clock dividers
- Eight 16-bit clock dividers for the digital system
- Four 16-bit clock dividers for the analog system
- Dedicated 16-bit divider for the bus clock
- Dedicated 4-bit divider for the CPU clock
- Automatic clock configuration in PSoC Creator

**Table 6-1. Oscillator Summary**

Source	Fmin	Tolerance at Fmin	Fmax	Tolerance at Fmax	Startup Time
IMO	3 MHz	±1% over voltage and temperature	24 MHz	±4%	10 μs max
MHzECO	4 MHz	Crystal dependent	25 MHz	Crystal dependent	5 ms typ, max is crystal dependent
DSI	0 MHz	Input dependent	50 MHz	Input dependent	Input dependent
PLL	24 MHz	Input dependent	50 MHz	Input dependent	250 μs max
Doubler	48 MHz	Input dependent	48 MHz	Input dependent	1 μs max
ILO	1 kHz	-50%, +100%	100 kHz	-55%, +100%	15 ms max in lowest power mode
kHzECO	32 kHz	Crystal dependent	32 kHz	Crystal dependent	500 ms typ, max is crystal dependent

**Figure 6-1. Clocking Subsystem**



**6.1.1 Internal Oscillators**

**6.1.1.1 Internal Main Oscillator**

In most designs the IMO is the only clock source required, due to its ±1-percent accuracy. The IMO operates with no external components and outputs a stable clock. A factory trim for each frequency range is stored in the device. With the factory trim, tolerance varies from ±1 percent at 3 MHz, up to ±4-percent at 24 MHz. The IMO, in conjunction with the PLL, allows generation of CPU and system clocks up to the device's maximum frequency (see [Phase-locked Loop](#))

The IMO provides clock outputs at 3, 6, 12, and 24 MHz.

**6.1.1.2 Clock Doubler**

The clock doubler outputs a clock at twice the frequency of the input clock. The doubler works at input frequency of 24 MHz, providing 48 MHz for the USB. It can be configured to use a clock from the IMO, MHzECO, or the DSI (external pin).

**6.1.1.3 Phase-locked Loop**

The PLL allows low-frequency, high-accuracy clocks to be multiplied to higher frequencies. This is a tradeoff between higher clock frequency and accuracy and, higher power consumption and increased startup time.

The PLL block provides a mechanism for generating clock frequencies based upon a variety of input sources. The PLL

outputs clock frequencies in the range of 24 to 50 MHz. Its input and feedback dividers supply 4032 discrete ratios to create almost any desired system clock frequency. The accuracy of the PLL output depends on the accuracy of the PLL input source. The most common PLL use is to multiply the IMO clock at 3 MHz, where it is most accurate to generate the CPU and system clocks up to the device's maximum frequency.

The PLL achieves phase lock within 250  $\mu$ s (verified by bit setting). It can be configured to use a clock from the IMO, MHzECO or DSI (external pin). The PLL clock source can be used until lock is complete and signaled with a lock bit. The lock signal can be routed through the DSI to generate an interrupt. Disable the PLL before entering low-power modes.

#### 6.1.1.4 Internal Low-Speed Oscillator

The ILO provides clock frequencies for low-power consumption, including the watchdog timer, and sleep timer. The ILO generates up to three different clocks: 1 kHz, 33 kHz, and 100 kHz.

The 1 kHz clock (CLK1K) is typically used for a background 'heartbeat' timer. This clock inherently lends itself to low-power supervisory operations such as the watchdog timer and long sleep intervals using the central timewheel (CTW).

The central timewheel is a 1 kHz, free running, 13-bit counter clocked by the ILO. The central timewheel is always enabled, except in hibernate mode and when the CPU is stopped during debug on chip mode. It can be used to generate periodic interrupts for timing purposes or to wake the system from a low-power mode. Firmware can reset the central timewheel. Systems that require accurate timing should use the RTC capability instead of the central timewheel.

The 100-kHz clock (CLK100K) works as a low-power system clock to run the CPU. It can also generate time intervals such as fast sleep intervals using the fast timewheel.

The fast timewheel is a 100-kHz, 5-bit counter clocked by the ILO that can also be used to wake the system. The fast timewheel settings are programmable, and the counter automatically resets when the terminal count is reached. This enables flexible, periodic wakeups of the CPU at a higher rate than is allowed using the central timewheel. The fast timewheel can generate an optional interrupt each time the terminal count is reached.

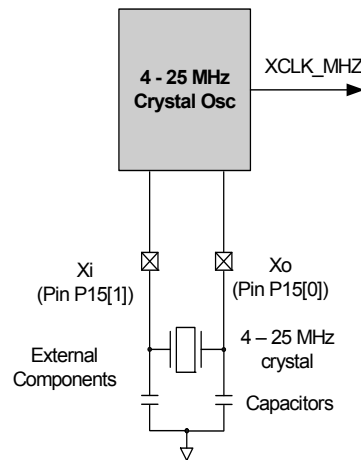
The 33-kHz clock (CLK33K) comes from a divide-by-3 operation on CLK100K. This output can be used as a reduced accuracy version of the 32.768-kHz ECO clock with no need for a crystal.

### 6.1.2 External Oscillators

#### 6.1.2.1 MHz External Crystal Oscillator

The MHzECO provides high frequency, high precision clocking using an external crystal (see Figure 6-2). It supports a wide variety of crystal types, in the range of 4 to 25 MHz. When used in conjunction with the PLL, it can generate CPU and system clocks up to the device's maximum frequency (see "Phase-locked Loop" section on page 27). The GPIO pins connecting to the external crystal and capacitors are fixed. MHzECO accuracy depends on the crystal chosen.

Figure 6-2. MHzECO Block Diagram

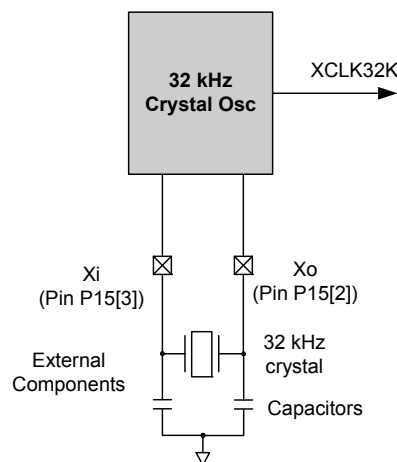


#### 6.1.2.2 32.768-kHz ECO

The 32.768-kHz External Crystal Oscillator (32kHzECO) provides precision timing with minimal power consumption using an external 32.768-kHz watch crystal (see Figure 6-3). The 32kHzECO also connects directly to the sleep timer and provides the source for the RTC. The RTC uses a 1-second interrupt to implement the RTC functionality in firmware.

The oscillator works in two distinct power modes. This allows users to trade off power consumption with noise immunity from neighboring circuits. The GPIO pins connected to the external crystal and capacitors are fixed.

Figure 6-3. 32kHzECO Block Diagram



#### 6.1.2.3 Digital System Interconnect

The DSI provides routing for clocks taken from external clock oscillators connected to I/O. The oscillators can also be generated within the device in the digital system and Universal Digital Blocks.

While the primary DSI clock input provides access to all clocking resources, up to eight other DSI clocks (internally or externally generated) may be routed directly to the eight digital clock

dividers. This is only possible if there are multiple precision clock sources.

### 6.1.3 Clock Distribution

All seven clock sources are inputs to the central clock distribution system. The distribution system is designed to create multiple high precision clocks. These clocks are customized for the design's requirements and eliminate the common problems found with limited resolution prescalers attached to peripherals. The clock distribution system generates several types of clock trees.

- The system clock is used to select and supply the fastest clock in the system for general system clock requirements and clock synchronization of the PSoC device.
- Bus Clock 16-bit divider uses the system clock to generate the system's bus clock used for data transfers. Bus clock is the source clock for the CPU clock divider.
- Eight fully programmable 16-bit clock dividers generate digital system clocks for general use in the digital system, as configured by the design's requirements. Digital system clocks can generate custom clocks derived from any of the seven clock sources for any purpose. Examples include baud rate generators, accurate PWM periods, and timer clocks, and many others. If more than eight digital clock dividers are required, the Universal Digital Blocks (UDBs) and fixed function Timer/Counter/PWMs can also generate clocks.
- Four 16-bit clock dividers generate clocks for the analog system components that require clocking, such as ADC. The analog clock dividers include skew control to ensure that critical analog events do not occur simultaneously with digital switching events. This is done to reduce analog system noise.

Each clock divider consists of an 8-input multiplexer, a 16-bit clock divider (divide by 2 and higher) that generates ~50 percent duty cycle clocks, system clock resynchronization logic, and deglitch logic. The outputs from each digital clock tree can be routed into the digital system interconnect and then brought back into the clock system as an input, allowing clock chaining of up to 32 bits.

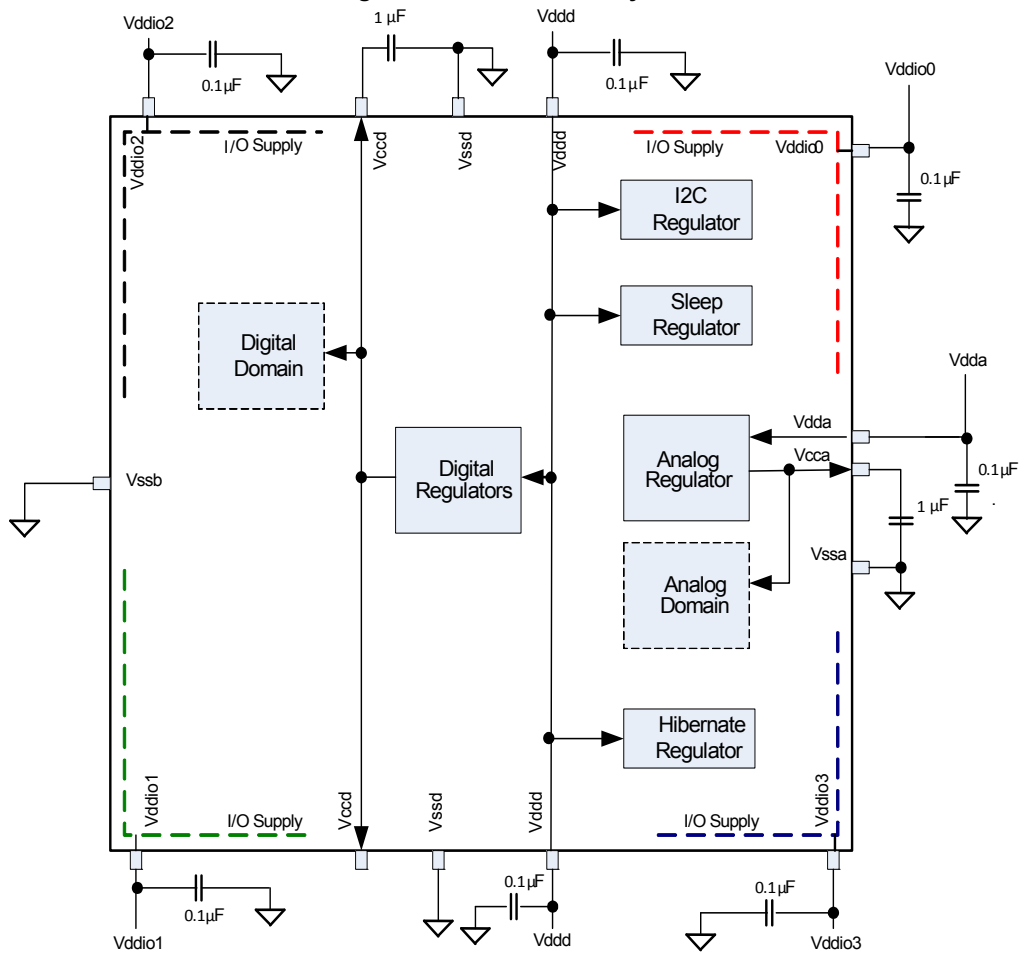
### 6.1.4 USB Clock Domain

The USB clock domain is unique in that it operates largely asynchronously from the main clock network. The USB logic contains a synchronous bus interface to the chip, while running on an asynchronous clock to process USB data. The USB logic requires a 48 MHz frequency. This frequency can be generated from different sources, including DSI clock at 48 MHz or doubled value of 24 MHz from internal oscillator, DSI signal, or crystal oscillator.

## 6.2 Power System

The power system consists of separate analog, digital, and I/O supply pins, labeled Vdda, Vddd, and Vddiox, respectively. It also includes two internal 1.8 V regulators that provide the digital (Vccd) and analog (Vcca) supplies for the internal core logic. The output pins of the regulators (Vccd and Vcca) and the Vddio pins must have capacitors connected as shown in [Figure 6-4](#). The two Vccd pins must be shorted together, with as short a trace as possible, and connected to a 1- $\mu$ F  $\pm$ 10-percent X5R capacitor. The power system also contains a sleep regulator, an I<sup>2</sup>C regulator, and a hibernate regulator.

**Figure 6-4. PSoC Power System**



**Note** The two V<sub>ccdd</sub> pins must be connected together with as short a trace as possible. A trace under the device is recommended, as shown in Figure 2-6.

### 6.2.1 Power Modes

PSoC 3 devices have four different power modes, as shown in [Table 6-2](#) and [Table 6-3](#). The power modes allow a design to easily provide required functionality and processing power while simultaneously minimizing power consumption and maximizing battery life in low-power and portable devices.

PSoC 3 power modes, in order of decreasing power consumption are:

- Active
- Alternate Active
- Sleep
- Hibernate

Active is the main processing mode. Its functionality is configurable. Each power controllable subsystem is enabled or disabled by using separate power configuration template registers. In alternate active mode, fewer subsystems are enabled, reducing power. In sleep mode most resources are disabled regardless of the template settings. Sleep mode is optimized to provide timed sleep intervals and RTC functionality. The lowest power mode is hibernate, which retains register and SRAM state, but no clocks, and allows wakeup only from I/O pins. [Figure 6-5](#) illustrates the allowable transitions between power modes.

**Table 6-2. Power Modes**

Power Modes	Description	Entry Condition	Wakeup Source	Active Clocks	Regulator
Active	Primary mode of operation, all peripherals available (programmable)	Wakeup, reset, manual register entry	Any interrupt	Any (programmable)	All regulators available. Digital and analog regulators can be disabled if external regulation used.
Alternate Active	Similar to Active mode, and is typically configured to have fewer peripherals active to reduce power. One possible configuration is to use the UDBs for processing, with the CPU turned off	Manual register entry	Any interrupt	Any (programmable)	All regulators available. Digital and analog regulators can be disabled if external regulation used.
Sleep	All subsystems automatically disabled	Manual register entry	Comparator, PICU, I <sup>2</sup> C, RTC, CTW, LVD	ILO/kHzECO	Both digital and analog regulators buzzed. Digital and analog regulators can be disabled if external regulation used.
Hibernate	All subsystems automatically disabled Lowest power consuming mode with all peripherals and internal regulators disabled, except hibernate regulator is enabled Configuration and memory contents retained	Manual register entry	PICU		Only hibernate regulator active.

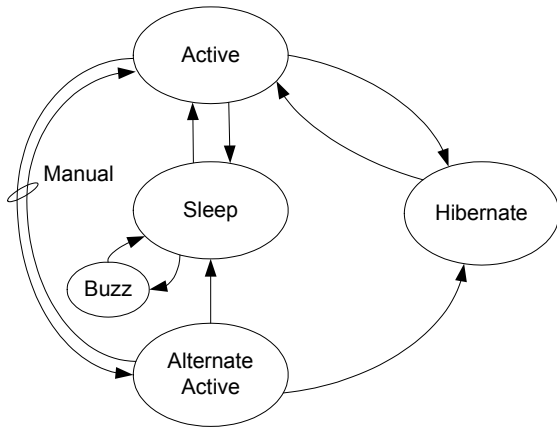
**Table 6-3. Power Modes Wakeup Time and Power Consumption**

Sleep Modes	Wakeup Time	Current (typ)	Code Execution	Digital Resources	Analog Resources	Clock Sources Available	Wakeup Sources	Reset Sources
Active	–	1.2 mA <sup>[12]</sup>	Yes	All	All	All	–	All
Alternate Active	–	–	User defined	All	All	All	–	All
Sleep	<15 μs	1 μA	No	I <sup>2</sup> C	Comparator	ILO/kHzECO	Comparator, PICU, I <sup>2</sup> C, RTC, CTW, LVD	XRES, LVD, WDR
Hibernate	<100 μs	200 nA	No	None	None	None	PICU	XRES

**Note**

12. Bus clock off. Execute from CPU instruction buffer at 6 MHz. See [Table 11-2](#) on page 65.

Figure 6-5. Power Mode Transitions



6.2.1.1 Active Mode

Active mode is the primary operating mode of the device. When in active mode, the active configuration template bits control which available resources are enabled or disabled. When a resource is disabled, the digital clocks are gated, analog bias currents are disabled, and leakage currents are reduced as appropriate. User firmware can dynamically control subsystem power by setting and clearing bits in the active configuration template. The CPU can disable itself, in which case the CPU is automatically reenabled at the next wakeup event.

When a wakeup event occurs, the global mode is always returned to active, and the CPU is automatically enabled, regardless of its template settings. Active mode is the default global power mode upon boot.

6.2.1.2 Alternate Active Mode

Alternate Active mode is very similar to Active mode. In alternate active mode, fewer subsystems are enabled, to reduce power consumption. One possible configuration is to turn off the CPU and flash, and run peripherals at full speed.

6.2.1.3 Sleep Mode

Sleep mode reduces power consumption when a resume time of 15  $\mu$ s is acceptable. The wake time is used to ensure that the regulator outputs are stable enough to directly enter active mode.

6.2.1.4 Hibernate Mode

In hibernate mode nearly all of the internal functions are disabled. Internal voltages are reduced to the minimal level to keep vital systems alive. Configuration state is preserved in hibernate mode and SRAM memory is retained. GPIOs configured as digital outputs maintain their previous values and external GPIO pin interrupt settings are preserved. The device can only return from hibernate mode in response to an external I/O interrupt. The resume time from hibernate mode is less than 100  $\mu$ s.

6.2.1.5 Wakeup Events

Wakeup events are configurable and can come from an interrupt or device reset. A wakeup event restores the system to active mode. Firmware enabled interrupt sources include internally generated interrupts, power supervisor, central timewheel, and I/O interrupts. Internal interrupt sources can come from a variety of peripherals, such as analog comparators and UDBs. The central timewheel provides periodic interrupts to allow the system to wake up, poll peripherals, or perform real-time functions. Reset event sources include the external reset I/O pin (XRES), WDT, and Precision Reset (PRES).

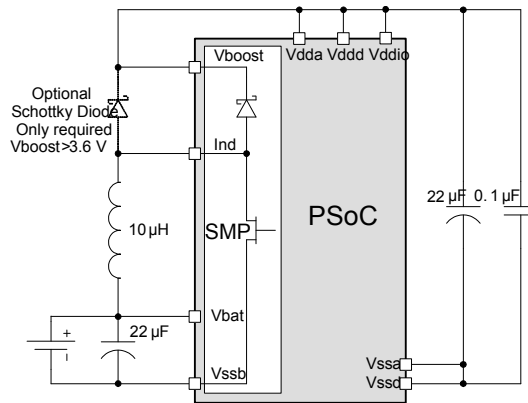
6.2.2 Boost Converter

Applications that use a supply voltage of less than 1.71 V, such as solar or single cell battery supplies, may use the on-chip boost converter. The boost converter may also be used in any system that requires a higher operating voltage than the supply provides. For instance, this includes driving 5.0 V LCD glass in a 3.3 V system. The boost converter accepts an input voltage as low as 0.5 V. With one low cost inductor it produces a selectable output voltage sourcing enough current to operate the PSoC and other on-board components.

The boost converter accepts an input voltage from 0.5 V to 5.5 V ( $V_{BAT}$ ), and can start up with  $V_{BAT}$  as low as 0.5 V. The converter provides a user configurable output voltage of 1.8 to 5.0 V ( $V_{BOOST}$ ).  $V_{BAT}$  is typically less than  $V_{BOOST}$ ; if  $V_{BAT}$  is greater than or equal to  $V_{BOOST}$ , then  $V_{BOOST}$  will be the same as  $V_{BAT}$ . The block can deliver up to 50 mA ( $I_{BOOST}$ ) depending on configuration.

Four pins are associated with the boost converter:  $V_{BAT}$ ,  $V_{SSB}$ ,  $V_{BOOST}$ , and  $Ind$ . The boosted output voltage is sensed at the  $V_{BOOST}$  pin and must be connected directly to the chip's supply inputs. An inductor is connected between the  $V_{BAT}$  and  $Ind$  pins. You can optimize the inductor value to increase the boost converter efficiency based on input voltage, output voltage, current and switching frequency. The External Schottky diode shown in Figure 6-6 is required only in cases when  $V_{BOOST} > 3.6$  V.

Figure 6-6. Application for Boost Converter





The switching frequency can be set to 100 kHz, 400 kHz, 2 MHz, or 32 kHz to optimize efficiency and component cost. The 100 kHz, 400 kHz, and 2 MHz switching frequencies are generated using oscillators internal to the boost converter block. When the 32-kHz switching frequency is selected, the clock is derived from a 32 kHz external crystal oscillator. The 32-kHz external clock is primarily intended for boost standby mode.

At 2 MHz the Vboost output is limited to 2 × Vbat, and at 400 kHz Vboost is limited to 4 × Vbat.

The boost converter can be operated in two different modes: active and standby. Active mode is the normal mode of operation where the boost regulator actively generates a regulated output voltage. In standby mode, most boost functions are disabled, thus reducing power consumption of the boost circuit. The converter can be configured to provide low-power, low-current regulation in the standby mode. The external 32 kHz crystal can be used to generate inductor boost pulses on the rising and falling edge of the clock when the output voltage is less than the programmed value. This is called automatic thump mode (ATM).

The boost typically draws 200 µA in active mode and 12 µA in standby mode. The boost operating modes must be used in conjunction with chip power modes to minimize the total chip power consumption. Table 6-4 lists the boost power modes available in different chip power modes.

**Table 6-4. Chip and Boost Power Modes Compatibility**

Chip Power Modes	Boost Power Modes
Chip – Active mode	Boost can be operated in either active or standby mode.
Chip – Sleep mode	Boost can be operated in either active or standby mode. However, it is recommended to operate boost in standby mode for low-power consumption
Chip – Hibernate mode	Boost can only be operated in active mode. However, it is recommended not to use boost in chip hibernate mode due to high current consumption in boost active mode

If the boost converter is not used in a given application, tie the V<sub>BAT</sub>, V<sub>SSB</sub>, and V<sub>BOOST</sub> pins to ground and leave the Ind pin unconnected.

### 6.3 Reset

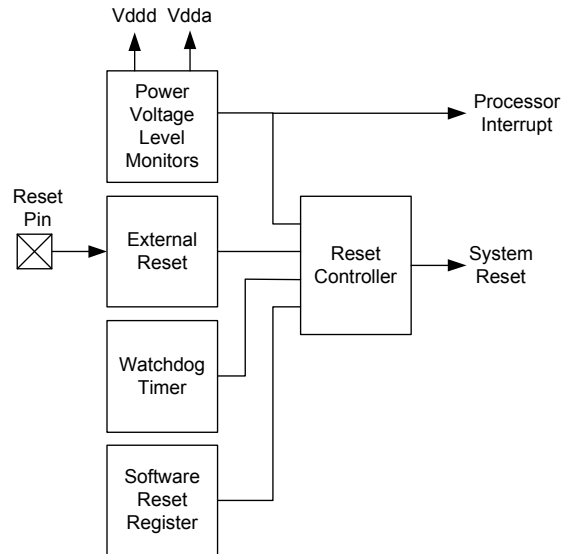
CY8C32 has multiple internal and external reset sources available. The reset sources are:

- Power source monitoring – The analog and digital power voltages, V<sub>DDA</sub>, V<sub>DDD</sub>, V<sub>CCA</sub>, and V<sub>CCD</sub> are monitored in several different modes during power up, active mode, and sleep mode (buzzing). If any of the voltages goes outside predetermined ranges then a reset is generated. The monitors are programmable to generate an interrupt to the processor under certain conditions before reaching the reset thresholds.
- External – The device can be reset from an external source by pulling the reset pin (XRES) low. The XRES pin includes an internal pull-up to V<sub>DDIO1</sub>. V<sub>DDD</sub>, V<sub>DDA</sub>, and V<sub>DDIO1</sub> must all have voltage applied before the part comes out of reset.
- Watchdog timer – A watchdog timer monitors the execution of instructions by the processor. If the watchdog timer is not reset

by firmware within a certain period of time, the watchdog timer generates a reset.

- Software – The device can be reset under program control.

**Figure 6-7. Resets**



The term **device reset** indicates that the processor as well as analog and digital peripherals and registers are reset.

A reset status register holds the source of the most recent reset or power voltage monitoring interrupt. The program may examine this register to detect and report exception conditions. This register is cleared after a power-on reset.

#### 6.3.1 Reset Sources

##### 6.3.1.1 Power Voltage Level Monitors

- IPOR – Initial Power-on Reset

At initial power-on, IPOR monitors the power voltages V<sub>DDD</sub> and V<sub>DDA</sub>, both directly at the pins and at the outputs of the corresponding internal regulators. The trip level is not precise. It is set to approximately 1 volt, which is below the lowest specified operating voltage but high enough for the internal circuits to be reset and to hold their reset state. The monitor generates a reset pulse that is at least 100 ns wide. It may be much wider if one or more of the voltages ramps up slowly.

To save power the IPOR circuit is disabled when the internal digital supply is stable. Voltage supervision is then handed off to the precise low voltage reset (PRES) circuit. When the voltage is high enough for PRES to release, the IMO starts.

- PRES – Precise Low Voltage Reset

This circuit monitors the outputs of the analog and digital internal regulators after power up. The regulator outputs are compared to a precise reference voltage. The response to a PRES trip is identical to an IPOR reset.

In normal operating mode, the program cannot disable the digital PRES circuit. The analog regulator can be disabled, which also disables the analog portion of the PRES. The PRES circuit is disabled automatically during sleep and hibernate modes, with one exception: During sleep mode the regulators are periodically activated (buzzed) to provide supervisory

services and to reduce wakeup time. At these times the PRES circuit is also buzzed to allow periodic voltage monitoring.

■ **ALVI, DLVI, AHVI – Analog/Digital Low Voltage Interrupt, Analog High Voltage Interrupt**

Interrupt circuits are available to detect when  $V_{DDA}$  and  $V_{DDD}$  go outside a voltage range. For AHVI,  $V_{DDA}$  is compared to a fixed trip level. For ALVI and DLVI,  $V_{DDA}$  and  $V_{DDD}$  are compared to trip levels that are programmable, as listed in Table 6-5. ALVI and DLVI can also be configured to generate a device reset instead of an interrupt.

**Table 6-5. Analog/Digital Low Voltage Interrupt, Analog High Voltage Interrupt**

Interrupt	Supply	Normal Voltage Range	Available Trip Settings	Accuracy
DLVI	$V_{DDD}$	1.71 V – 5.5 V	1.70 V – 5.45 V in 250 mV increments	±2%
ALVI	$V_{DDA}$	1.71 V – 5.5 V	1.70 V – 5.45 V in 250 mV increments	±2%
AHVI	$V_{DDA}$	1.71 V – 5.5 V	5.75 V	±2%

The monitors are disabled until after IPOR. During sleep mode these circuits are periodically activated (buzzed). If an interrupt occurs during buzzing then the system first enters its wake up sequence. The interrupt is then recognized and may be serviced.

6.3.1.2 *Other Reset Sources*

■ **XRES – External Reset**

PSoC 3 has either a single GPIO pin that is configured as an external reset or a dedicated XRES pin. Either the dedicated XRES pin or the GPIO pin, if configured, holds the part in reset while held active (low). The response to an XRES is the same as to an IPOR reset.

The external reset is active low. It includes an internal pull-up resistor. XRES is active during sleep and hibernate modes.

■ **SRES – Software Reset**

A reset can be commanded under program control by setting a bit in the software reset register. This is done either directly by the program or indirectly by DMA access. The response to a SRES is the same as after an IPOR reset.

Another register bit exists to disable this function.

■ **WRES – Watchdog Timer Reset**

The watchdog reset detects when the software program is no longer being executed correctly. To indicate to the watchdog timer that it is running correctly, the program must periodically reset the timer. If the timer is not reset before a user-specified amount of time, then a reset is generated.

**Note** IPOR disables the watchdog function. The program must enable the watchdog function at an appropriate point in the code by setting a register bit. When this bit is set, it cannot be cleared again except by an IPOR power-on reset event.

**6.4 I/O System and Routing**

PSoC I/Os are extremely flexible. Every GPIO has analog and digital I/O capability. All I/Os have a large number of drive modes, which are set at POR. PSoC also provides up to four individual I/O voltage domains through the  $V_{DDIO}$  pins.

There are two types of I/O pins on every device; those with USB provide a third type. Both GPIO and Special I/O (SIO) provide similar digital functionality. The primary differences are their analog capability and drive strength. Devices that include USB also provide two USBIO pins that support specific USB functionality as well as limited GPIO capability.

All I/O pins are available for use as digital inputs and outputs for both the CPU and digital peripherals. In addition, all I/O pins can generate an interrupt. The flexible and advanced capabilities of the PSoC I/O, combined with any signal to any pin routability, greatly simplify circuit design and board layout. All GPIO pins can be used for analog input, CapSense, and LCD segment drive, while SIO pins are used for voltages in excess of  $V_{DDA}$  and for programmable output voltages.

- Features supported by both GPIO and SIO:
  - User programmable port reset state
  - Separate I/O supplies and voltages for up to four groups of I/O
  - Digital peripherals use DSI to connect the pins
  - Input or output or both for CPU and DMA
  - Eight drive modes
  - Every pin can be an interrupt source configured as rising edge, falling edge or both edges. If required, level sensitive interrupts are supported through the DSI
  - Dedicated port interrupt vector for each port
  - Slew rate controlled digital output drive mode
  - Access port control and configuration registers on either port basis or pin basis
  - Separate port read (PS) and write (DR) data registers to avoid read modify write errors
  - Special functionality on a pin by pin basis
- Additional features only provided on the GPIO pins:
  - LCD segment drive on LCD equipped devices
  - CapSense
  - Analog input and output capability
  - Continuous 100  $\mu$ A clamp current capability
  - Standard drive strength down to 1.7 V
- Additional features only provided on SIO pins:
  - Higher drive strength than GPIO
  - Hot swap capability (5 V tolerance at any operating  $V_{DD}$ )
  - Programmable and regulated high input and output drive levels down to 1.2 V
  - No analog input, CapSense, or LCD capability
  - Over voltage tolerance up to 5.5 V
  - SIO can act as a general purpose analog comparator
- USBIO features:
  - Full speed USB 2.0 compliant I/O
  - Highest drive strength for general purpose use
  - Input, output, or both for CPU and DMA
  - Input, output, or both for digital peripherals
  - Digital output (CMOS) drive mode
  - Each pin can be an interrupt source configured as rising edge, falling edge, or both edges

**Figure 6-8. GPIO Block Diagram**

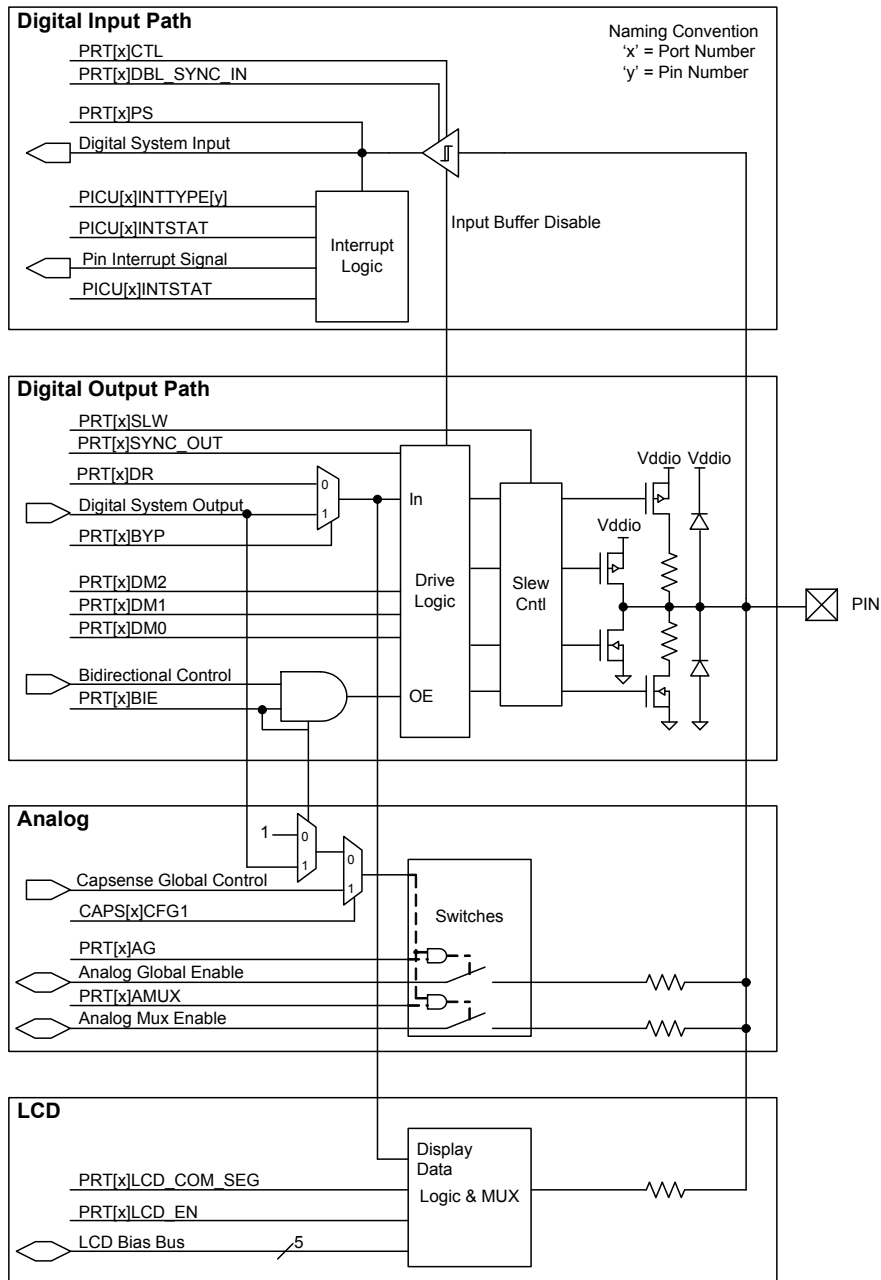


Figure 6-9. SIO Input/Output Block Diagram

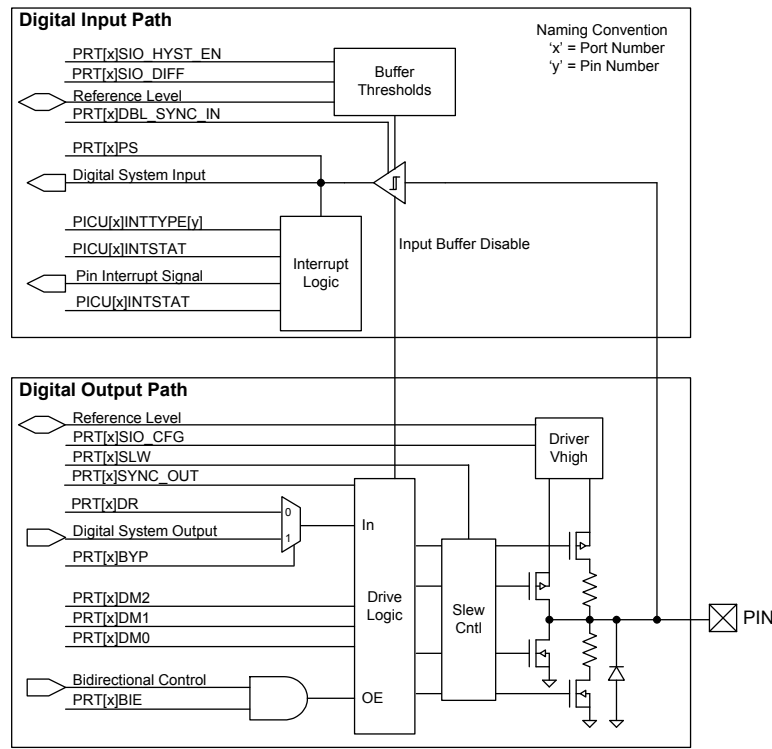
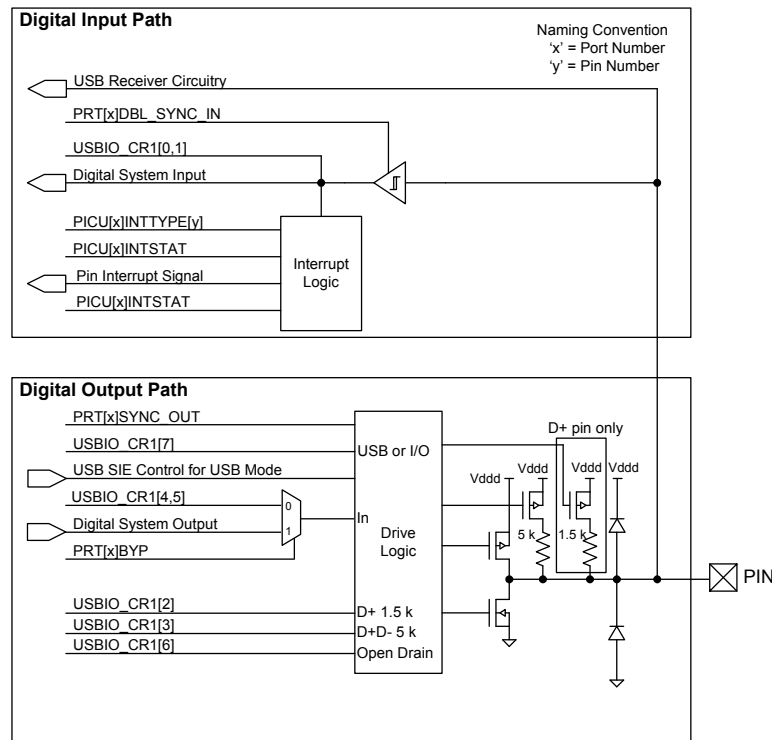


Figure 6-10. USBIO Block Diagram



### 6.4.1 Drive Modes

Each GPIO and SIO pin is individually configurable into one of the eight drive modes listed in Table 6-6. Three configuration bits are used for each pin (DM[2:0]) and set in the PRTxDM[2:0] registers. Figure 6-11 depicts a simplified pin view based on each of the eight drive modes. Table 6-6 shows the I/O pin's drive state based on the port data register value or digital array signal if bypass mode is selected. Note that the actual I/O pin voltage is determined by a combination of the selected drive mode and the load at the pin. For example, if a GPIO pin is configured for resistive pull-up mode and driven high while the pin is floating, the voltage measured at the pin is a high logic state. If the same GPIO pin is externally tied to ground then the voltage unmeasured at the pin is a low logic state.

Figure 6-11. Drive Mode

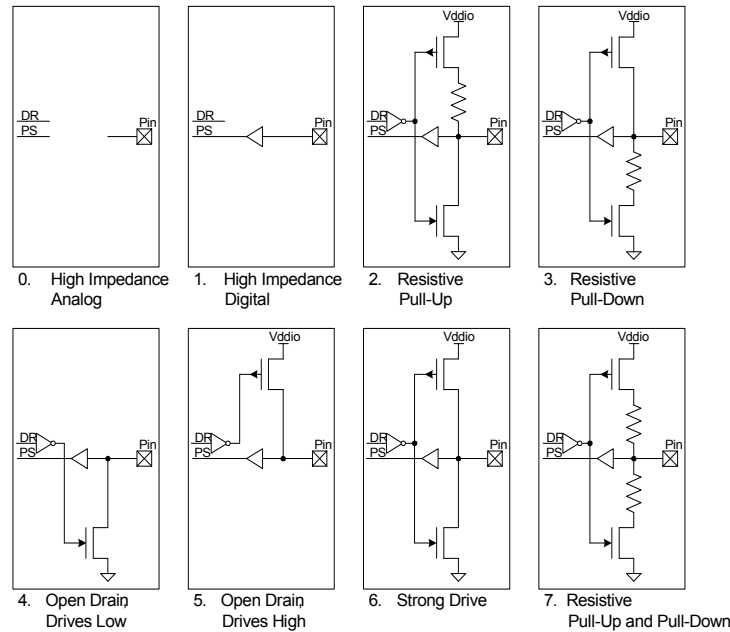


Table 6-6. Drive Modes

Diagram	Drive Mode	PRTxDM2	PRTxDM1	PRTxDM0	PRTxDR = 1	PRTxDR = 0
0	High impedance analog	0	0	0	High Z	High Z
1	High Impedance digital	0	0	1	High Z	High Z
2	Resistive pull-up <sup>[13]</sup>	0	1	0	Res High (5K)	Strong Low
3	Resistive pull-down <sup>[13]</sup>	0	1	1	Strong High	Res Low (5K)
4	Open drain, drives low	1	0	0	High Z	Strong Low
5	Open drain, drive high	1	0	1	Strong High	High Z
6	Strong drive	1	1	0	Strong High	Strong Low
7	Resistive pull-up and pull-down <sup>[13]</sup>	1	1	1	Res High (5K)	Res Low (5K)

**Note**

<sup>13</sup>. Resistive pull-up and pull-down are not available with SIO in regulated output mode.

## ■ High Impedance Analog

The default reset state with both the output driver and digital input buffer turned off. This prevents any current from flowing in the I/O's digital input buffer due to a floating voltage. This state is recommended for pins that are floating or that support an analog voltage. High impedance analog pins do not provide digital input functionality.

To achieve the lowest chip current in sleep modes, all I/Os must either be configured to the high impedance analog mode, or have their pins driven to a power supply rail by the PSoC device or by external circuitry.

## ■ High Impedance Digital

The input buffer is enabled for digital signal input. This is the standard high impedance (HiZ) state recommended for digital inputs.

## ■ Resistive pull-up or resistive pull-down

Resistive pull-up or pull-down, respectively, provides a series resistance in one of the data states and strong drive in the other. Pins can be used for digital input and output in these modes. Interfacing to mechanical switches is a common application for these modes. Resistive pull-up and pull-down are not available with SIO in regulated output mode.

## ■ Open Drain, Drives High and Open Drain, Drives Low

Open drain modes provide high impedance in one of the data states and strong drive in the other. Pins can be used for digital input and output in these modes. A common application for these modes is driving the I<sup>2</sup>C bus signal lines.

## ■ Strong Drive

Provides a strong CMOS output drive in either high or low state. This is the standard output mode for pins. Strong Drive mode pins must not be used as inputs under normal circumstances. This mode is often used to drive digital output signals or external FETs.

## ■ Resistive pull-up and pull-down

Similar to the resistive pull-up and resistive pull-down modes except the pin is always in series with a resistor. The high data state is pull-up while the low data state is pull-down. This mode is most often used when other signals that may cause shorts can drive the bus. Resistive pull-up and pull-down are not available with SIO in regulated output mode.

### 6.4.2 Pin Registers

Registers to configure and interact with pins come in two forms that may be used interchangeably.

All I/O registers are available in the standard port form, where each bit of the register corresponds to one of the port pins. This register form is efficient for quickly reconfiguring multiple port pins at the same time.

I/O registers are also available in pin form, which combines the eight most commonly used port register bits into a single register for each pin. This enables very fast configuration changes to individual pins with a single register write.

### 6.4.3 Bidirectional Mode

High-speed bidirectional capability allows pins to provide both the high impedance digital drive mode for input signals and a second user selected drive mode such as strong drive (set using PRT×DM[2:0] registers) for output signals on the same pin, based on the state of an auxiliary control bus signal. The bidirectional capability is useful for processor busses and communications interfaces such as the SPI Slave MISO pin that requires dynamic hardware control of the output buffer.

The auxiliary control bus routes up to 16 UDB or digital peripheral generated output enable signals to one or more pins.

### 6.4.4 Slew Rate Limited Mode

GPIO and SIO pins have fast and slow output slew rate options for strong and open drain drive modes, not resistive drive modes. Because it results in reduced EMI, the slow edge rate option is recommended for signals that are not speed critical, generally less than 1 MHz. The fast slew rate is for signals between 1 MHz and 33 MHz. The slew rate is individually configurable for each pin, and is set by the PRT×SLW registers.

### 6.4.5 Pin Interrupts

All GPIO and SIO pins are able to generate interrupts to the system. All eight pins in each port interface to their own Port Interrupt Control Unit (PICU) and associated interrupt vector. Each pin of the port is independently configurable to detect rising edge, falling edge, both edge interrupts, or to not generate an interrupt.

Depending on the configured mode for each pin, each time an interrupt event occurs on a pin, its corresponding status bit of the interrupt status register is set to "1" and an interrupt request is sent to the interrupt controller. Each PICU has its own interrupt vector in the interrupt controller and the pin status register providing easy determination of the interrupt source down to the pin level.

Port pin interrupts remain active in all sleep modes allowing the PSoC device to wake from an externally generated interrupt.

While level sensitive interrupts are not directly supported; Universal Digital Blocks (UDB) provide this functionality to the system when needed.

### 6.4.6 Input Buffer Mode

GPIO and SIO input buffers can be configured at the port level for the default CMOS input thresholds or the optional LVTTTL input thresholds. All input buffers incorporate Schmitt triggers for input hysteresis. Additionally, individual pin input buffers can be disabled in any drive mode.

### 6.4.7 I/O Power Supplies

Up to four I/O pin power supplies are provided depending on the device and package. Each I/O supply must be less than or equal to the voltage on the chip's analog (V<sub>DDA</sub>) pin. This feature allows users to provide different I/O voltage levels for different pins on the device. Refer to the specific device package pinout to determine V<sub>DDIO</sub> capability for a given port and pin.

The SIO port pins support an additional regulated high output capability, as described in [Adjustable Output Level](#).

#### 6.4.8 Analog Connections

These connections apply only to GPIO pins. All GPIO pins may be used as analog inputs or outputs. The analog voltage present on the pin must not exceed the  $V_{DDIO}$  supply voltage to which the GPIO belongs. Each GPIO may connect to one of the analog global busses or to one of the analog mux buses to connect any pin to any internal analog resource such as ADC or comparators. In addition, one select pin provides direct connection to the high current DAC.

#### 6.4.9 CapSense

This section applies only to GPIO pins. All GPIO pins may be used to create CapSense buttons and sliders. See the “CapSense” section on page 57 for more information.

#### 6.4.10 LCD Segment Drive

This section applies only to GPIO pins. All GPIO pins may be used to generate Segment and Common drive signals for direct glass drive of LCD glass. See the “LCD Direct Drive” section on page 57 for details.

#### 6.4.11 Adjustable Output Level

This section applies only to SIO pins. SIO port pins support the ability to provide a regulated high output level for interface to external signals that are lower in voltage than the SIO’s respective  $V_{DDIO}$ . SIO pins are individually configurable to output either the standard  $V_{DDIO}$  level or the regulated output, which is based on an internally generated reference. Typically the voltage DAC (VDAC) is used to generate the reference (see Figure 6-12). The “DAC” section on page 58 has more details on VDAC use and reference routing to the SIO pins. Resistive pull-up and pull-down drive modes are not available with SIO in regulated output mode.

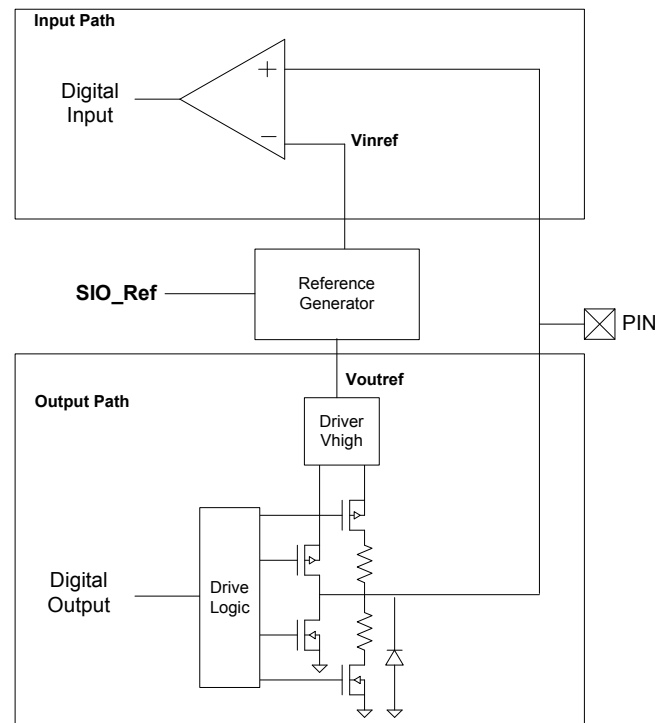
#### 6.4.12 Adjustable Input Level

This section applies only to SIO pins. SIO pins by default support the standard CMOS and LVTTTL input levels but also support a differential mode with programmable levels. SIO pins are grouped into pairs. Each pair shares a reference generator block which, is used to set the digital input buffer reference level for interface to external signals that differ in voltage from  $V_{DDIO}$ . The reference sets the pins voltage threshold for a high logic level (see Figure 6-12). Available input thresholds are:

- $0.5 \times V_{ddio}$
- $0.4 \times V_{ddio}$
- $0.5 \times V_{REF}$
- $V_{REF}$

Typically the voltage DAC (VDAC) generates the  $V_{REF}$  reference. The “DAC” section on page 58 has more details on VDAC use and reference routing to the SIO pins.

Figure 6-12. SIO Reference for Input and Output



#### 6.4.13 SIO as Comparator

This section applies only to SIO pins. The adjustable input level feature of the SIOs as explained in the Adjustable Input Level section can be used to construct a comparator. The threshold for the comparator is provided by the SIO’s reference generator. The reference generator has the option to set the analog signal routed through the analog global line as threshold for the comparator. Note that a pair of SIO pins share the same threshold.

The digital input path in Figure 6-9 on page 36 illustrates this functionality. In the figure, ‘Reference level’ is the analog signal routed through the analog global. The hysteresis feature can also be enabled for the input buffer of the SIO, which increases noise immunity for the comparator.

#### 6.4.14 Hot Swap

This section applies only to SIO pins. SIO pins support ‘hot swap’ capability to plug into an application without loading the signals that are connected to the SIO pins even when no power is applied to the PSoC device. This allows the unpowered PSoC to maintain a high impedance load to the external device while also preventing the PSoC from being powered through a GPIO pin’s protection diode.

#### 6.4.15 Over Voltage Tolerance

All I/O pins provide an over voltage tolerance feature at any operating  $V_{DD}$ .

- There are no current limitations for the SIO pins as they present a high impedance load to the external circuit where  $V_{DDIO} \leq V_{IN} \leq 5.5\text{ V}$ .
- The GPIO pins must be limited to 100  $\mu\text{A}$  using a current limiting resistor. GPIO pins clamp the pin voltage to approximately one diode above the  $V_{DDIO}$  supply where  $V_{DDIO} \leq V_{IN} \leq V_{DDA}$ .
- In case of a GPIO pin configured for analog input/output, the analog voltage on the pin must not exceed the  $V_{DDIO}$  supply voltage to which the GPIO belongs.

A common application for this feature is connection to a bus such as I<sup>2</sup>C where different devices are running from different supply voltages. In the I<sup>2</sup>C case, the PSoC chip is configured into the Open Drain, Drives Low mode for the SIO pin. This allows an external pull-up to pull the I<sup>2</sup>C bus voltage above the PSoC pin supply. For example, the PSoC chip could operate at 1.8 V, and an external device could run from 5 V. Note that the SIO pin's  $V_{IH}$  and  $V_{IL}$  levels are determined by the associated  $V_{DDIO}$  supply pin.

The I/O pin must be configured into a high impedance drive mode, open drain low drive mode, or pull-down drive mode, for over voltage tolerance to work properly. Absolute maximum ratings for the device must be observed for all I/O pins.

#### 6.4.16 Reset Configuration

While reset is active all I/Os are reset to and held in the High Impedance Analog state. After reset is released, the state can be reprogrammed on a port-by-port basis to pull-down or pull-up. To ensure correct reset operation, the port reset configuration data is stored in special nonvolatile registers. The stored reset data is automatically transferred to the port reset configuration registers at reset release.

#### 6.4.17 Low-Power Functionality

In all low-power modes the I/O pins retain their state until the part is awakened and changed or reset. To awaken the part, use a pin interrupt, because the port interrupt logic continues to function in all low-power modes.

#### 6.4.18 Special Pin Functionality

Some pins on the device include additional special functionality in addition to their GPIO or SIO functionality. The specific special function pins are listed in [Pinouts](#) on page 5. The special features are:

- Digital
  - 4- to 25- MHz crystal oscillator
  - 32.768-kHz crystal oscillator
  - Wake from sleep on I<sup>2</sup>C address match. Any pin can be used for I<sup>2</sup>C if wake from sleep is not required.
  - JTAG interface pins
  - SWD interface pins
  - SWV interface pins
  - External reset

- Analog

- High current IDAC output
- External reference inputs

#### 6.4.19 JTAG Boundary Scan

The device supports standard JTAG boundary scan chains on all I/O pins for board level test.

## 7. Digital Subsystem

The digital programmable system creates application specific combinations of both standard and advanced digital peripherals and custom logic functions. These peripherals and logic are then interconnected to each other and to any pin on the device, providing a high level of design flexibility and IP security.

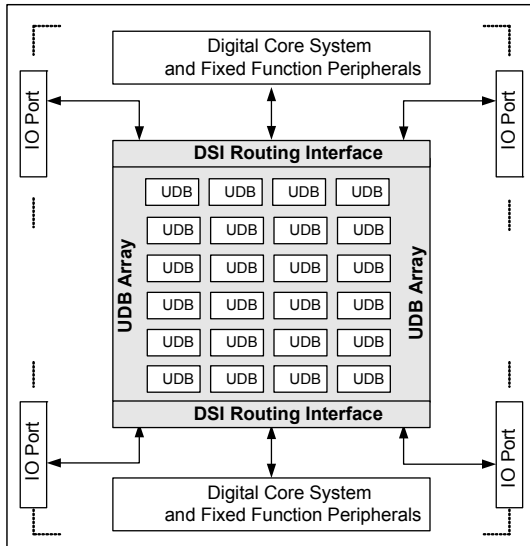
The features of the digital programmable system are outlined here to provide an overview of capabilities and architecture. You do not need to interact directly with the programmable digital system at the hardware and register level. PSoC Creator provides a high level schematic capture graphical interface to automatically place and route resources similar to PLDs.

The main components of the digital programmable system are:

- Universal Digital Blocks (UDB) – These form the core functionality of the digital programmable system. UDBs are a collection of uncommitted logic (PLD) and structural logic (Datapath) optimized to create all common embedded peripherals and customized functionality that are application or design specific.
- Universal Digital Block Array – UDB blocks are arrayed within a matrix of programmable interconnect. The UDB array structure is homogeneous and allows for flexible mapping of digital functions onto the array. The array supports extensive and flexible routing interconnects between UDBs and the Digital System Interconnect.
- Digital System Interconnect (DSI) – Digital signals from Universal Digital Blocks (UDBs), fixed function peripherals, I/O pins, interrupts, DMA, and other system core signals are attached to the Digital System Interconnect to implement full featured device connectivity. The DSI allows any digital function to any pin or other feature routability when used with the Universal Digital Block Array.



**Figure 7-1. CY8C32 Digital Programmable Architecture**



**7.1 Example Peripherals**

The flexibility of the CY8C32 family’s Universal Digital Blocks (UDBs) and Analog Blocks allow the user to create a wide range of components (peripherals). The most common peripherals were built and characterized by Cypress and are shown in the PSoC Creator component catalog, however, users may also create their own custom components using PSoC Creator. Using PSoC Creator, users may also create their own components for reuse within their organization, for example sensor interfaces, proprietary algorithms, and display interfaces.

The number of components available through PSoC Creator is too numerous to list in the datasheet, and the list is always growing. An example of a component available for use in CY8C32 family, but, not explicitly called out in this datasheet is the UART component.

**7.1.1 Example Digital Components**

The following is a sample of the digital components available in PSoC Creator for the CY8C32 family. The exact amount of hardware resources (UDBs, routing, RAM, flash) used by a component varies with the features selected in PSoC Creator for the component.

- Communications
  - I<sup>2</sup>C
  - UART
  - SPI
- Functions
  - EMIF
  - PWMs
  - Timers
  - Counters
- Logic
  - NOT
  - OR
  - XOR
  - AND

**7.1.2 Example Analog Components**

The following is a sample of the analog components available in PSoC Creator for the CY8C32 family. The exact amount of hardware resources (routing, RAM, flash) used by a component varies with the features selected in PSoC Creator for the component.

- ADC
  - Delta-sigma
- DACs
  - Current
  - Voltage
  - PWM
- Comparators

**7.1.3 Example System Function Components**

The following is a sample of the system function components available in PSoC Creator for the CY8C32 family. The exact amount of hardware resources (UDBs, routing, RAM, flash) used by a component varies with the features selected in PSoC Creator for the component.

- CapSense
- LCD Drive
- LCD Control

**7.1.4 Designing with PSoC Creator**

**7.1.4.1 More Than a Typical IDE**

A successful design tool allows for the rapid development and deployment of both simple and complex designs. It reduces or eliminates any learning curve. It makes the integration of a new design into the production stream straightforward.

PSoC Creator is that design tool.

PSoC Creator is a full featured Integrated Development Environment (IDE) for hardware and software design. It is optimized specifically for PSoC devices and combines a modern, powerful software development platform with a sophisticated graphical design tool. This unique combination of tools makes PSoC Creator the most flexible embedded design platform available.

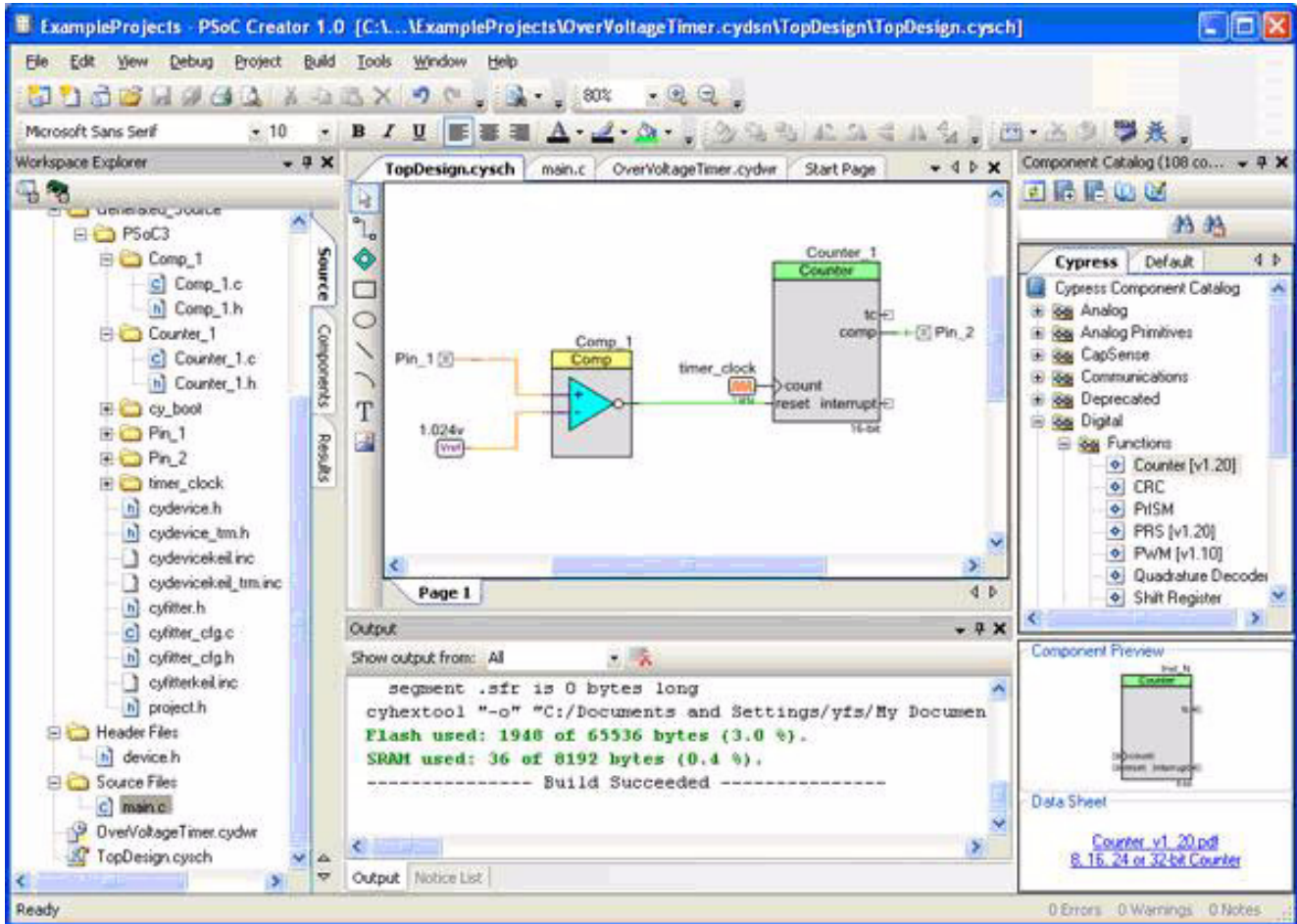
Graphical design entry simplifies the task of configuring a particular part. You can select the required functionality from an extensive catalog of components and place it in your design. All components are parameterized and have an editor dialog that allows you to tailor functionality to your needs.

PSoC Creator automatically configures clocks and routes the I/O to the selected pins and then generates APIs to give the application complete control over the hardware. Changing the PSoC device configuration is as simple as adding a new component, setting its parameters, and rebuilding the project.

At any stage of development you are free to change the hardware configuration and even the target processor. To retarget your application (hardware and software) to new devices, even from 8- to 32-bit families, just select the new device and rebuild.

You also have the ability to change the C compiler and evaluate an alternative. Components are designed for portability and are validated against all devices, from all families, and against all supported tool chains. Switching compilers is as easy as editing the from the project options and rebuilding the application with no errors from the generated APIs or boot code.

Figure 7-2. PSoC Creator Framework





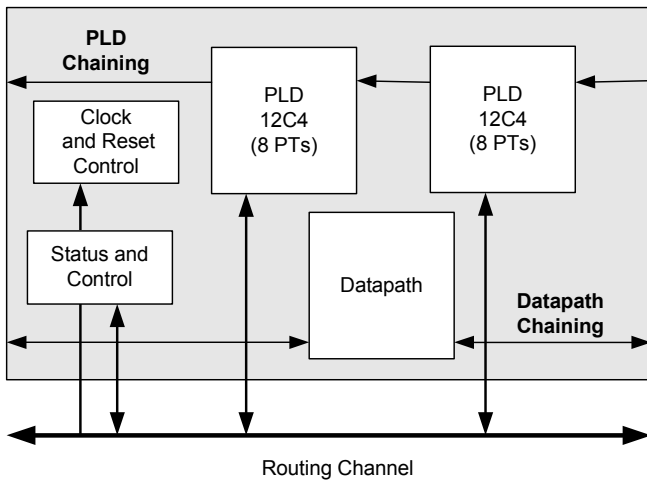
PSoC Creator contains all the tools necessary to complete a design, and then to maintain and extend that design for years to come. All steps of the design flow are carefully integrated and optimized for ease-of-use and to maximize productivity.

### 7.2 Universal Digital Block

The Universal Digital Block (UDB) represents an evolutionary step to the next generation of PSoC embedded digital peripheral functionality. The architecture in first generation PSoC digital blocks provides coarse programmability in which a few fixed functions with a small number of options are available. The new UDB architecture is the optimal balance between configuration granularity and efficient implementation. A cornerstone of this approach is to provide the ability to customize the devices digital operation to match application requirements.

To achieve this, UDBs consist of a combination of uncommitted logic (PLD), structured logic (Datapath), and a flexible routing scheme to provide interconnect between these elements, I/O connections, and other peripherals. UDB functionality ranges from simple self contained functions that are implemented in one UDB, or even a portion of a UDB (unused resources are available for other functions), to more complex functions that require multiple UDBs. Examples of basic functions are timers, counters, CRC generators, PWMs, dead band generators, and communications functions, such as UARTs, SPI, and I<sup>2</sup>C. Also, the PLD blocks and connectivity provide full featured general purpose programmable logic within the limits of the available resources.

Figure 7-6. UDB Block Diagram



The main component blocks of the UDB are:

- **PLD blocks** – There are two small PLDs per UDB. These blocks take inputs from the routing array and form registered or combinational sum-of-products logic. PLDs are used to implement state machines, state bits, and combinational logic equations. PLD configuration is automatically generated from graphical primitives.
- **Datapath Module** – This 8-bit wide datapath contains structured logic to implement a dynamically configurable ALU, a variety of compare configurations and condition generation. This block

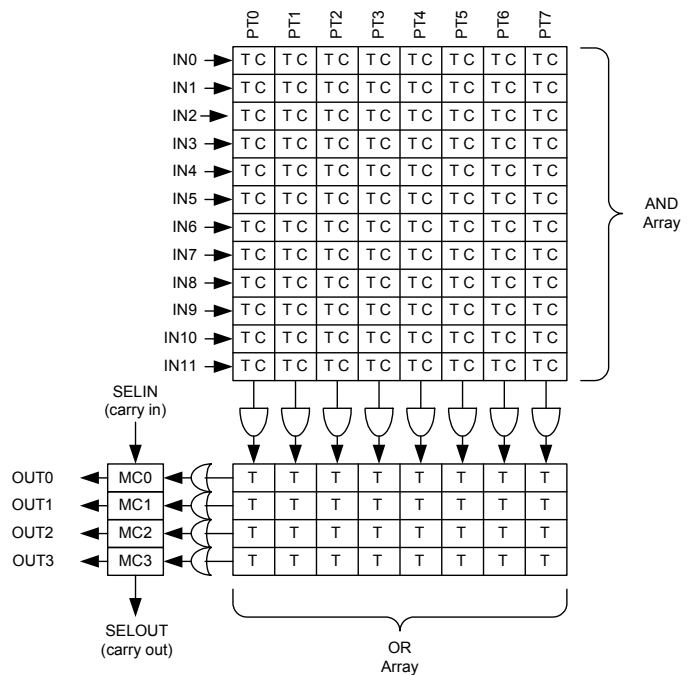
also contains input/output FIFOs, which are the primary parallel data interface between the CPU/DMA system and the UDB.

- **Status and Control Module** – The primary role of this block is to provide a way for CPU firmware to interact and synchronize with UDB operation.
- **Clock and Reset Module** – This block provides the UDB clocks and reset selection and control.

#### 7.2.1 PLD Module

The primary purpose of the PLD blocks is to implement logic expressions, state machines, sequencers, lookup tables, and decoders. In the simplest use model, consider the PLD blocks as a standalone resource onto which general purpose RTL is synthesized and mapped. The more common and efficient use model is to create digital functions from a combination of PLD and datapath blocks, where the PLD implements only the random logic and state portion of the function while the datapath (ALU) implements the more structured elements.

Figure 7-7. PLD 12C4 Structure

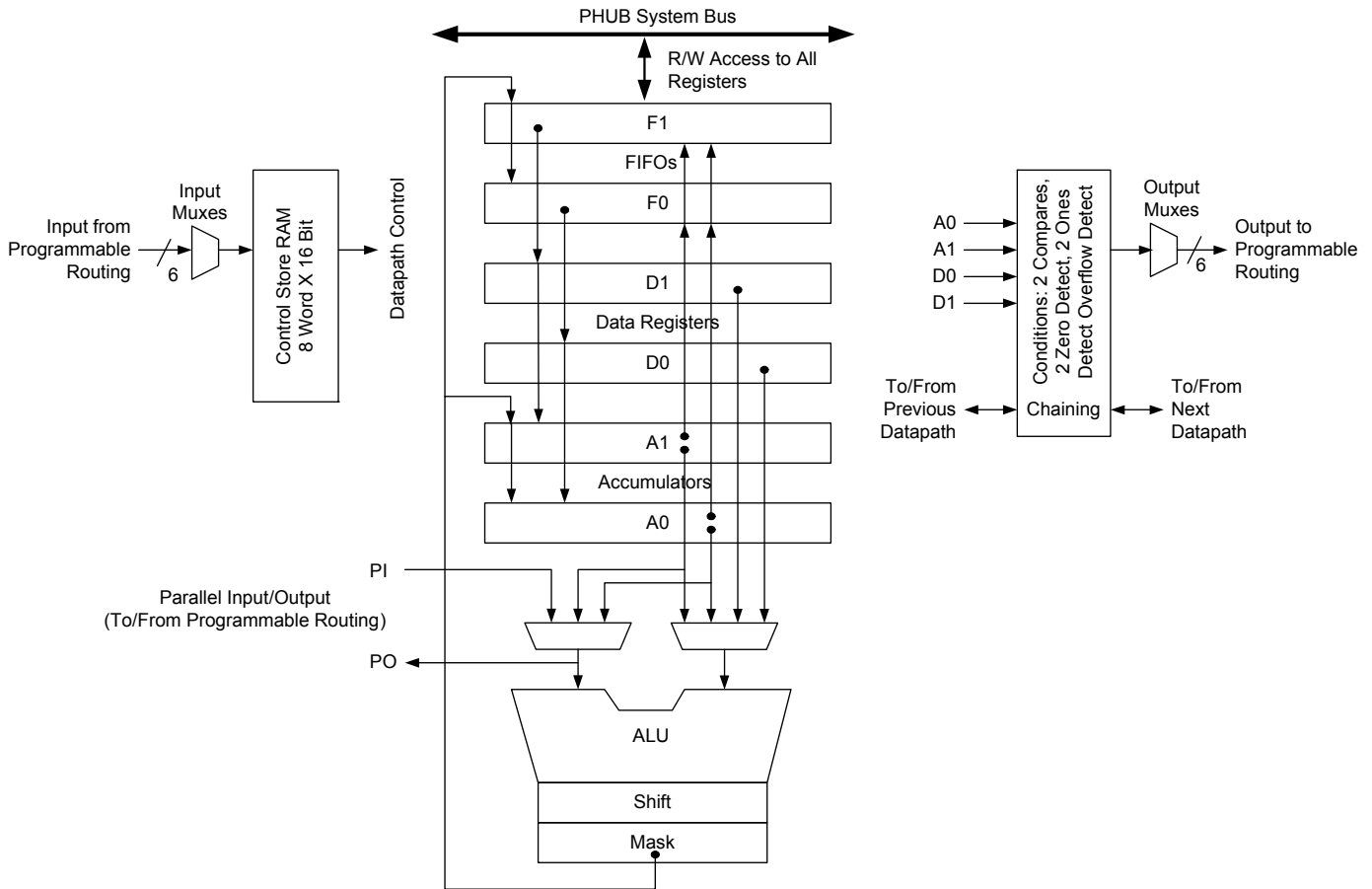


One 12C4 PLD block is shown in Figure 7-7. This PLD has 12 inputs, which feed across eight product terms. Each product term (AND function) can be from 1 to 12 inputs wide, and in a given product term, the true (T) or complement (C) of each input can be selected. The product terms are summed (OR function) to create the PLD outputs. A sum can be from 1 to 8 product terms wide. The 'C' in 12C4 indicates that the width of the OR gate (in this case 8) is constant across all outputs (rather than variable as in a 22V10 device). This PLA like structure gives maximum flexibility and insures that all inputs and outputs are permutable for ease of allocation by the software tools. There are two 12C4 PLDs in each UDB.

**7.2.2 Datapath Module**

The datapath contains an 8-bit single cycle ALU, with associated compare and condition generation logic. This datapath block is optimized to implement embedded functions, such as timers, counters, integrators, PWMs, PRS, CRC, shifters and dead band generators and many others.

**Figure 7-8. Datapath Top Level**



**7.2.2.1 Working Registers**

The datapath contains six primary working registers, which are accessed by CPU firmware or DMA during normal operation.

**Table 7-1. Working Datapath Registers**

Name	Function	Description
A0 and A1	Accumulators	These are sources and sinks for the ALU and also sources for the compares.
D0 and D1	Data Registers	These are sources for the ALU and sources for the compares.
F0 and F1	FIFOs	These are the primary interface to the system bus. They can be a data source for the data registers and accumulators or they can capture data from the accumulators or ALU. Each FIFO is four bytes deep.

**7.2.2.2 Dynamic Datapath Configuration RAM**

Dynamic configuration is the ability to change the datapath function and internal configuration on a cycle-by-cycle basis, under sequencer control. This is implemented using the 8-word × 16-bit configuration RAM, which stores eight unique 16-bit wide configurations. The address input to this RAM controls the sequence, and can be routed from any block connected to the UDB routing matrix, most typically PLD logic, I/O pins, or from the outputs of this or other datapath blocks.

**ALU**

The ALU performs eight general purpose functions. They are:

- Increment
- Decrement
- Add
- Subtract
- Logical AND
- Logical OR
- Logical XOR
- Pass, used to pass a value through the ALU to the shift register, mask, or another UDB register

Independent of the ALU operation, these functions are available:

- Shift left
- Shift right
- Nibble swap
- Bitwise OR mask

### 7.2.2.3 Conditionals

Each datapath has two compares, with bit masking options. Compare operands include the two accumulators and the two data registers in a variety of configurations. Other conditions include zero detect, all ones detect, and overflow. These conditions are the primary datapath outputs, a selection of which can be driven out to the UDB routing matrix. Conditional computation can use the built in chaining to neighboring UDBs to operate on wider data widths without the need to use routing resources.

### 7.2.2.4 Variable MSB

The most significant bit of an arithmetic and shift function can be programmatically specified. This supports variable width CRC and PRS functions, and in conjunction with ALU output masking, can implement arbitrary width timers, counters and shift blocks.

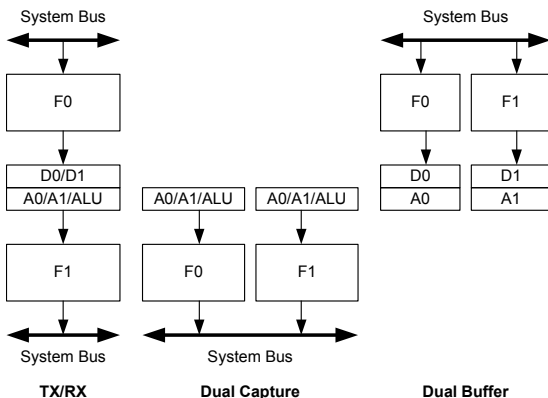
### 7.2.2.5 Built in CRC/PRS

The datapath has built in support for single cycle Cyclic Redundancy Check (CRC) computation and Pseudo Random Sequence (PRS) generation of arbitrary width and arbitrary polynomial. CRC/PRS functions longer than 8 bits may be implemented in conjunction with PLD logic, or built in chaining may be use to extend the function into neighboring UDBs.

### 7.2.2.6 Input/Output FIFOs

Each datapath contains two four-byte deep FIFOs, which can be independently configured as an input buffer (system bus writes to the FIFO, datapath internal reads the FIFO), or an output buffer (datapath internal writes to the FIFO, the system bus reads from the FIFO). The FIFOs generate status that are selectable as datapath outputs and can therefore be driven to the routing, to interact with sequencers, interrupts, or DMA.

**Figure 7-9. Example FIFO Configurations**



### 7.2.2.7 Chaining

The datapath can be configured to chain conditions and signals such as carries and shift data with neighboring datapaths to create higher precision arithmetic, shift, CRC/PRS functions.

### 7.2.2.8 Time Multiplexing

In applications that are over sampled, or do not need high clock rates, the single ALU block in the datapath can be efficiently shared with two sets of registers and condition generators. Carry and shift out data from the ALU are registered and can be selected as inputs in subsequent cycles. This provides support for 16-bit functions in one (8-bit) datapath.

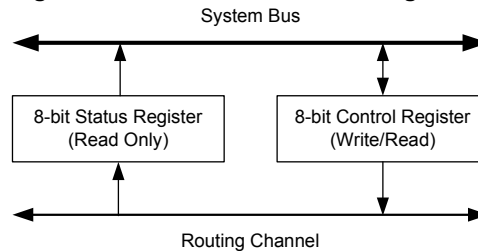
### 7.2.2.9 Datapath I/O

There are six inputs and six outputs that connect the datapath to the routing matrix. Inputs from the routing provide the configuration for the datapath operation to perform in each cycle, and the serial data inputs. Inputs can be routed from other UDB blocks, other device peripherals, device I/O pins, and so on. The outputs to the routing can be selected from the generated conditions, and the serial data outputs. Outputs can be routed to other UDB blocks, device peripherals, interrupt and DMA controller, I/O pins, and so on.

### 7.2.3 Status and Control Module

The primary purpose of this circuitry is to coordinate CPU firmware interaction with internal UDB operation.

**Figure 7-10. Status and Control Registers**



The bits of the control register, which may be written to by the system bus, are used to drive into the routing matrix, and thus provide firmware with the opportunity to control the state of UDB processing. The status register is read-only and it allows internal UDB state to be read out onto the system bus directly from internal routing. This allows firmware to monitor the state of UDB processing. Each bit of these registers has programmable connections to the routing matrix and routing connections are made depending on the requirements of the application.

### 7.2.3.1 Usage Examples

As an example of control input, a bit in the control register can be allocated as a function enable bit. There are multiple ways to enable a function. In one method the control bit output would be routed to the clock control block in one or more UDBs and serve as a clock enable for the selected UDB blocks. A status example is a case where a PLD or datapath block generated a condition, such as a “compare true” condition that is captured and latched by the status register and then read (and cleared) by CPU firmware.

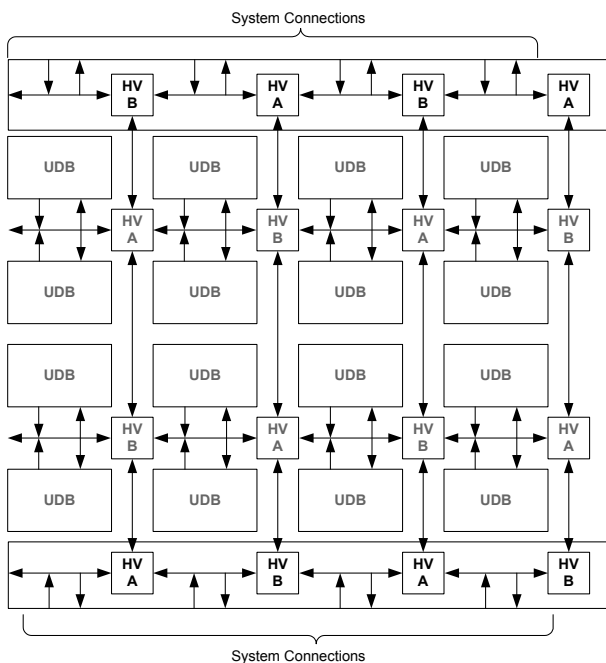
### 7.2.3.2 Clock Generation

Each subcomponent block of a UDB including the two PLDs, the datapath, and Status and Control, has a clock selection and control block. This promotes a fine granularity with respect to allocating clocking resources to UDB component blocks and allows unused UDB resources to be used by other functions for maximum system efficiency.

## 7.3 UDB Array Description

Figure 7-11 shows an example of a 16 UDB array. In addition to the array core, there are DSI routing interfaces at the top and bottom of the array. Other interfaces that are not explicitly shown include the system interfaces for bus and clock distribution. The UDB array includes multiple horizontal and vertical routing channels each comprised of 96 wires. The wire connections to UDBs, at horizontal/vertical intersection and at the DSI interface are highly permutable providing efficient automatic routing in PSoC Creator. Additionally the routing allows wire by wire segmentation along the vertical and horizontal routing to further increase routing flexibility and capability.

Figure 7-11. Digital System Interface Structure

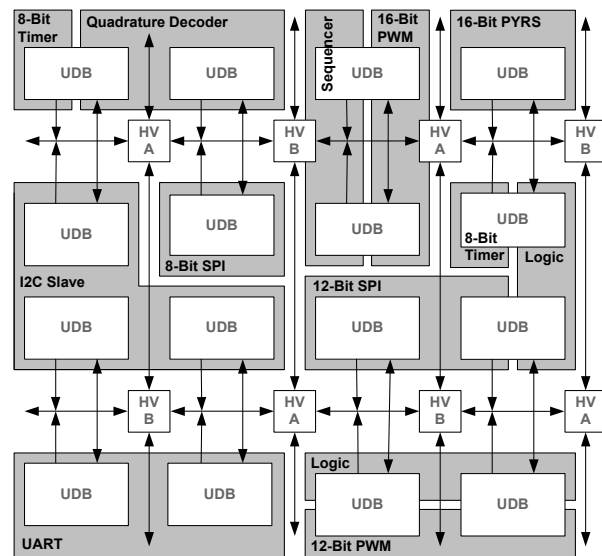


### 7.3.1 UDB Array Programmable Resources

Figure 7-12 shows an example of how functions are mapped into a bank of 16 UDBs. The primary programmable resources of the UDB are two PLDs, one datapath and one status/control register. These resources are allocated independently, because they have independently selectable clocks, and therefore unused blocks are allocated to other unrelated functions.

An example of this is the 8-bit Timer in the upper left corner of the array. This function only requires one datapath in the UDB, and therefore the PLD resources may be allocated to another function. A function such as a Quadrature Decoder may require more PLD logic than one UDB can supply and in this case can utilize the unused PLD blocks in the 8-bit Timer UDB. Programmable resources in the UDB array are generally homogeneous so functions can be mapped to arbitrary boundaries in the array.

Figure 7-12. Function Mapping Example in a Bank of UDBs



## 7.4 DSI Routing Interface Description

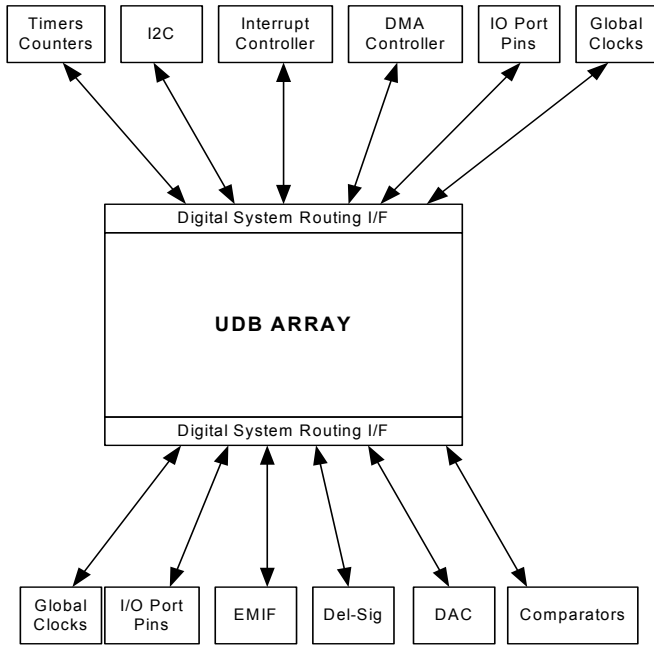
The DSI routing interface is a continuation of the horizontal and vertical routing channels at the top and bottom of the UDB array core. It provides general purpose programmable routing between device peripherals, including UDBs, I/Os, analog peripherals, interrupts, DMA and fixed function peripherals.

Figure 7-13 illustrates the concept of the digital system interconnect, which connects the UDB array routing matrix with other device peripherals. Any digital core or fixed function peripheral that needs programmable routing is connected to this interface.

Signals in this category include:

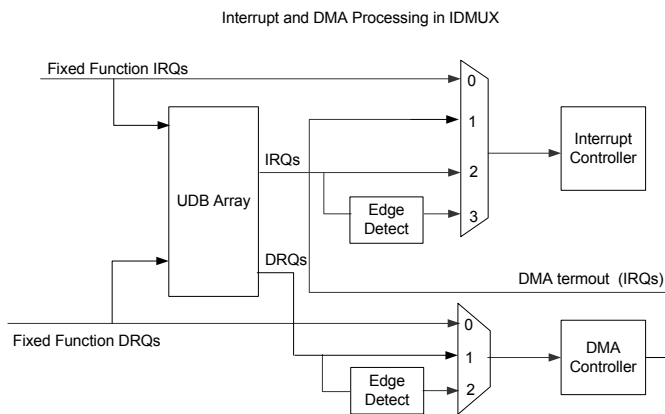
- Interrupt requests from all digital peripherals in the system.
- DMA requests from all digital peripherals in the system.
- Digital peripheral data signals that need flexible routing to I/Os.
- Digital peripheral data signals that need connections to UDBs.
- Connections to the interrupt and DMA controllers.
- Connection to I/O pins.
- Connection to analog system digital signals.

**Figure 7-13. Digital System Interconnect**



Interrupt and DMA routing is very flexible in the CY8C32 programmable architecture. In addition to the numerous fixed function peripherals that can generate interrupt requests, any data signal in the UDB array routing can also be used to generate a request. A single peripheral may generate multiple independent interrupt requests simplifying system and firmware design. Figure 7-14 shows the structure of the IDMUX (Interrupt/DMA Multiplexer).

**Figure 7-14. Interrupt and DMA Processing in the IDMUX**



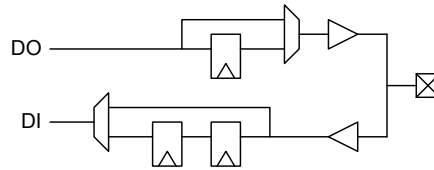
**7.4.1 I/O Port Routing**

There are a total of 20 DSI routes to a typical 8-bit I/O port, 16 for data and four for drive strength control.

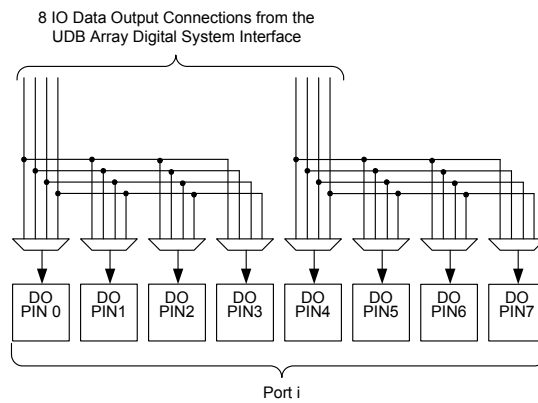
When an I/O pin is connected to the routing, there are two primary connections available, an input and an output. In

conjunction with drive strength control, this can implement a bidirectional I/O pin. A data output signal has the option to be single synchronized (pipelined) and a data input signal has the option to be double synchronized. The synchronization clock is the system clock (see Figure 6-1). Normally all inputs from pins are synchronized as this is required if the CPU interacts with the signal or any signal derived from it. Asynchronous inputs have rare uses. An example of this is a feed through of combinational PLD logic from input pins to output pins.

**Figure 7-15. I/O Pin Synchronization Routing**

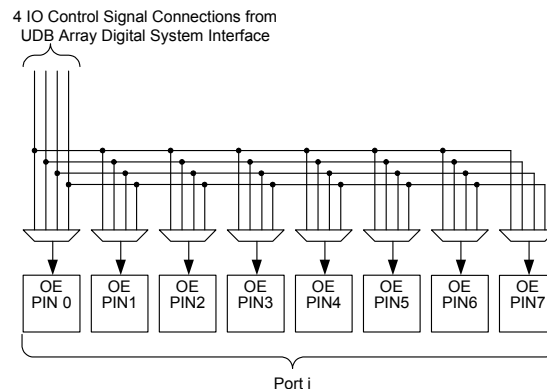


**Figure 7-16. I/O Pin Output Connectivity**



There are four more DSI connections to a given I/O port to implement dynamic output enable control of pins. This connectivity gives a range of options, from fully ganged 8-bits controlled by one signal, to up to four individually controlled pins. The output enable signal is useful for creating tri-state bidirectional pins and buses.

**Figure 7-17. I/O Pin Output Enable Connectivity**





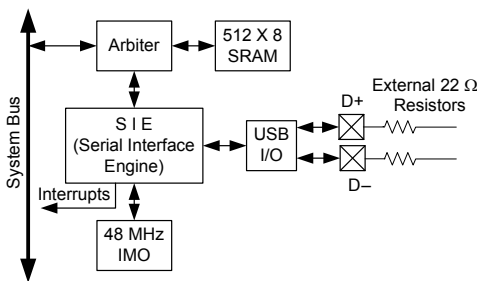
### 7.5 USB

PSoC includes a dedicated Full-Speed (12 Mbps) USB 2.0 transceiver supporting all four USB transfer types: control, interrupt, bulk, and isochronous. PSoC Creator provides full configuration support. USB interfaces to hosts through two dedicated USBIO pins, which are detailed in the “I/O System and Routing” section on page 34.

USB includes the following features:

- Eight unidirectional data endpoints
- One bidirectional control endpoint 0 (EP0)
- Shared 512-byte buffer for the eight data endpoints
- Dedicated 8-byte buffer for EP0
- Three memory modes
  - Manual Memory Management with No DMA Access
  - Manual Memory Management with Manual DMA Access
  - Automatic Memory Management with Automatic DMA Access
- Internal 3.3 V regulator for transceiver
- Internal 48 MHz main oscillator mode that auto locks to USB bus clock, requiring no external crystal for USB (USB equipped parts only)
- Interrupts on bus and each endpoint event, with device wakeup
- USB Reset, Suspend, and Resume operations
- Bus powered and self powered modes

**Figure 7-18. USB**



### 7.6 Timers, Counters, and PWMs

The Timer/Counter/PWM peripheral is a 16-bit dedicated peripheral providing three of the most common embedded peripheral features. As almost all embedded systems use some combination of timers, counters, and PWMs. Four of them have been included on this PSoC device family. Additional and more advanced functionality timers, counters, and PWMs can also be instantiated in Universal Digital Blocks (UDBs) as required. PSoC Creator allows you to choose the timer, counter, and PWM features that they require. The tool set utilizes the most optimal resources available.

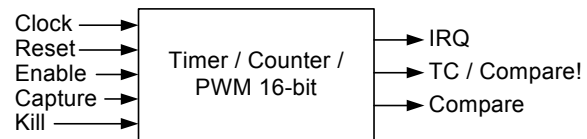
The Timer/Counter/PWM peripheral can select from multiple clock sources, with input and output signals connected through the DSI routing. DSI routing allows input and output connections

to any device pin and any internal digital signal accessible through the DSI. Each of the four instances has a compare output, terminal count output (optional complementary compare output), and programmable interrupt request line. The Timer/Counter/PWMs are configurable as free running, one shot, or Enable input controlled. The peripheral has timer reset and capture inputs, and a kill input for control of the comparator outputs. The peripheral supports full 16-bit capture.

Timer/Counter/PWM features include:

- 16-bit Timer/Counter/PWM (down count only)
- Selectable clock source
- PWM comparator (configurable for LT, LTE, EQ, GTE, GT)
- Period reload on start, reset, and terminal count
- Interrupt on terminal count, compare true, or capture
- Dynamic counter reads
- Timer capture mode
- Count while enable signal is asserted mode
- Free run mode
- One Shot mode (stop at end of period)
- Complementary PWM outputs with deadband
- PWM output kill

**Figure 7-19. Timer/Counter/PWM**



### 7.7 I<sup>2</sup>C

The I<sup>2</sup>C peripheral provides a synchronous two wire interface designed to interface the PSoC device with a two wire I<sup>2</sup>C serial communication bus. The bus is compliant with Philips ‘The I<sup>2</sup>C Specification’ version 2.1. Additional I<sup>2</sup>C interfaces can be instantiated using Universal Digital Blocks (UDBs) in PSoC Creator, as required.

To eliminate the need for excessive CPU intervention and overhead, I<sup>2</sup>C specific support is provided for status detection and generation of framing bits. I<sup>2</sup>C operates as a slave, a master, or multimaster (Slave and Master). In slave mode, the unit always listens for a start condition to begin sending or receiving data. Master mode supplies the ability to generate the Start and Stop conditions and initiate transactions. Multimaster mode provides clock synchronization and arbitration to allow multiple masters on the same bus. If Master mode is enabled and Slave mode is not enabled, the block does not generate interrupts on externally generated Start conditions. I<sup>2</sup>C interfaces through the DSI routing and allows direct connections to any GPIO or SIO pins.

I<sup>2</sup>C provides hardware address detect of a 7-bit address without CPU intervention. Additionally the device can wake from low-power modes on a 7-bit hardware address match. If wakeup functionality is required, I<sup>2</sup>C pin connections are limited to the two special sets of SIO pins.

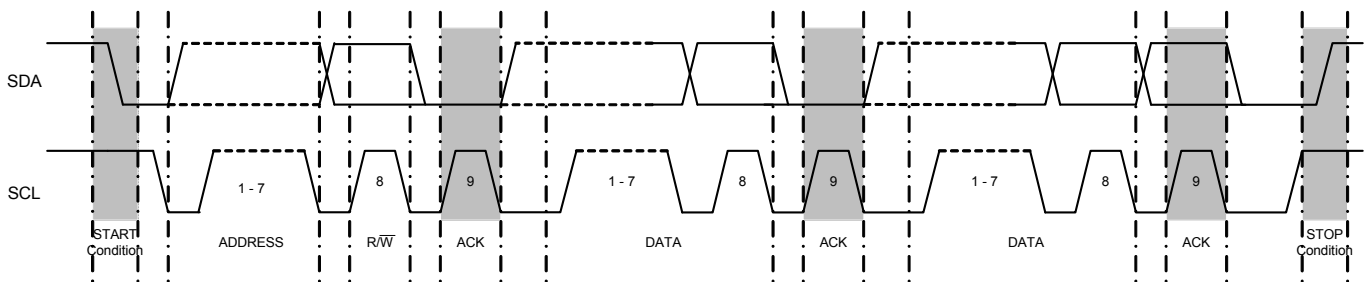
I<sup>2</sup>C features include:

- Slave and Master, Transmitter, and Receiver operation
- Byte processing for low CPU overhead
- Interrupt or polling CPU interface
- Support for bus speeds up to 1 Mbps (3.4 Mbps in UDBs)
- 7 or 10-bit addressing (10-bit addressing requires firmware support)

- SMBus operation (through firmware support – SMBus supported in hardware in UDBs)
- 7-bit hardware address compare
- Wake from low-power modes on address match

Data transfers follow the format shown in [Figure 7-20](#). After the START condition (S), a slave address is sent. This address is 7 bits long followed by an eighth bit which is a data direction bit (R/W) - a 'zero' indicates a transmission (WRITE), a 'one' indicates a request for data (READ). A data transfer is always terminated by a STOP condition (P) generated by the master. However, if a master still wishes to communicate on the bus, it can generate a repeated START condition (Sr) and address another slave without first generating a STOP condition. Various combinations of read/write formats are then possible within such a transfer.

**Figure 7-20. I<sup>2</sup>C Complete Transfer Timing**



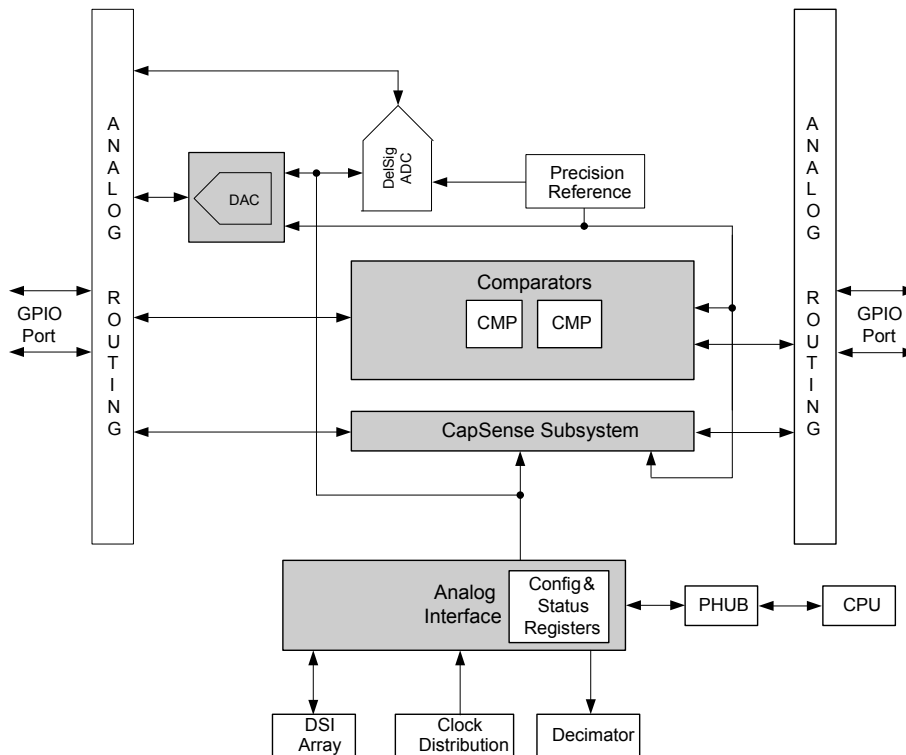
## 8. Analog Subsystem

The analog programmable system creates application specific combinations of both standard and advanced analog signal processing blocks. These blocks are then interconnected to each other and also to any pin on the device, providing a high level of design flexibility and IP security. The features of the analog subsystem are outlined here to provide an overview of capabilities and architecture.

- Flexible, configurable analog routing architecture provided by analog globals, analog mux bus, and analog local buses.

- High resolution delta-sigma ADC.
- One 8-bit DAC that provides either voltage or current output.
- Two comparators with optional connection to configurable LUT outputs.
- CapSense subsystem to enable capacitive touch sensing.
- Precision reference for generating an accurate analog voltage for internal analog blocks.

Figure 8-1. Analog Subsystem Block Diagram



The PSoC Creator software program provides a user friendly interface to configure the analog connections between the GPIO and various analog resources and connections from one analog resource to another. PSoC Creator also provides component libraries that allow you to configure the various analog blocks to perform application specific functions. The tool also generates API interface libraries that allow you to write firmware that allows the communication between the analog peripheral and CPU/Memory.

## 8.1 Analog Routing

The CY8C32 family of devices has a flexible analog routing architecture that provides the capability to connect GPIOs and different analog blocks, and also route signals between different analog blocks. One of the strong points of this flexible routing architecture is that it allows dynamic routing of input and output connections to the different analog blocks.

For information on how to make pin selections for optimal analog routing, refer to the application note, [AN58304 - PSoC<sup>®</sup> 3 and PSoC<sup>®</sup> 5 - Pin Selection for Analog Designs](#).

### 8.1.1 Features

- Flexible, configurable analog routing architecture
- 16 analog globals (AG) and two analog mux buses (AMUXBUS) to connect GPIOs and the analog blocks
- Each GPIO is connected to one analog global and one analog mux bus

- Eight analog local buses (abus) to route signals between the different analog blocks
- Multiplexers and switches for input and output selection of the analog blocks

### 8.1.2 Functional Description

Analog globals (AGs) and analog mux buses (AMUXBUS) provide analog connectivity between GPIOs and the various analog blocks. There are 16 AGs in the CY8C32 family. The analog routing architecture is divided into four quadrants as shown in [Figure 8-2](#). Each quadrant has four analog globals (AGL[0..3], AGL[4..7], AGR[0..3], AGR[4..7]). Each GPIO is connected to the corresponding AG through an analog switch. The analog mux bus is a shared routing resource that connects to every GPIO through an analog switch. There are two AMUXBUS routes in CY8C32, one in the left half (AMUXBUSL) and one in the right half (AMUXBUSR), as shown in [Figure 8-2](#).



Analog local buses (abus) are routing resources located within the analog subsystem and are used to route signals between different analog blocks. There are eight abus routes in CY8C32, four in the left half (abusl [0:3]) and four in the right half (abusr [0:3]) as shown in Figure 8-2. Using the abus saves the analog globals and analog mux buses from being used for interconnecting the analog blocks.

Multiplexers and switches exist on the various buses to direct signals into and out of the analog blocks. A multiplexer can have only one connection on at a time, whereas a switch can have multiple connections on simultaneously. In Figure 8-2, multiplexers are indicated by grayed ovals and switches are indicated by transparent ovals.

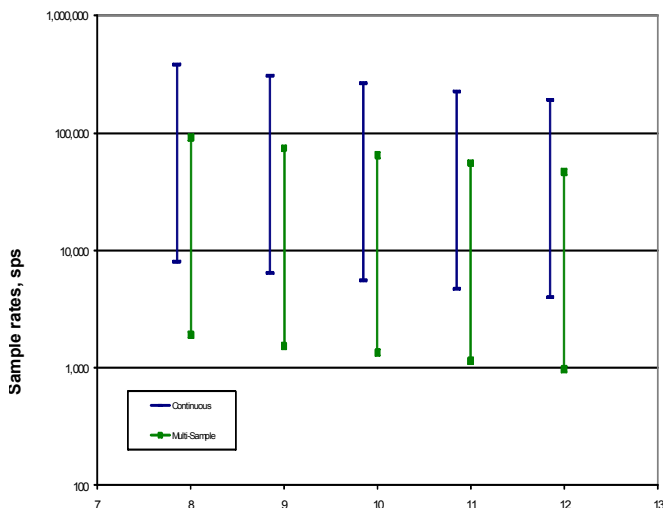
## 8.2 Delta-sigma ADC

The CY8C32 device contains one delta-sigma ADC. This ADC offers differential input, high resolution and excellent linearity, making it a good ADC choice for measurement applications. The converter can be configured to output 12-bit resolution at data rates of up to 192 ksps. At a fixed clock rate, resolution can be traded for faster data rates as shown in Table 8-1 and Figure 8-3.

Table 8-1. Delta-sigma ADC Performance

Bits	Maximum Sample Rate (sps)	SINAD (dB)
12	192 k	66
8	384 k	43

Figure 8-3. Delta-sigma ADC Sample Rates, Range = ±1.024 V



### 8.2.1 Functional Description

The ADC connects and configures three basic components, input buffer, delta-sigma modulator, and decimator. The basic block diagram is shown in Figure 8-4. The signal from the input

muxes is delivered to the delta-sigma modulator either directly or through the input buffer. The delta-sigma modulator performs the actual analog to digital conversion. The modulator over-samples the input and generates a serial data stream output. This high speed data stream is not useful for most applications without some type of post processing, and so is passed to the decimator through the Analog Interface block. The decimator converts the high speed serial data stream into parallel ADC results. The modulator/decimator frequency response is  $[(\sin x)/x]^4$ ; a typical frequency response is shown in Figure 8-5.

Figure 8-4. Delta-sigma ADC Block Diagram

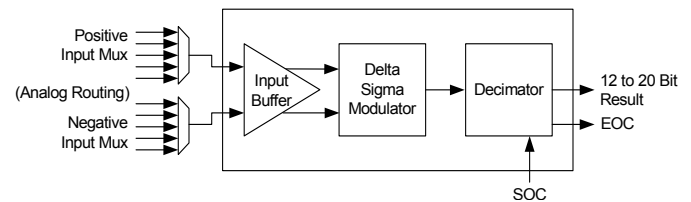
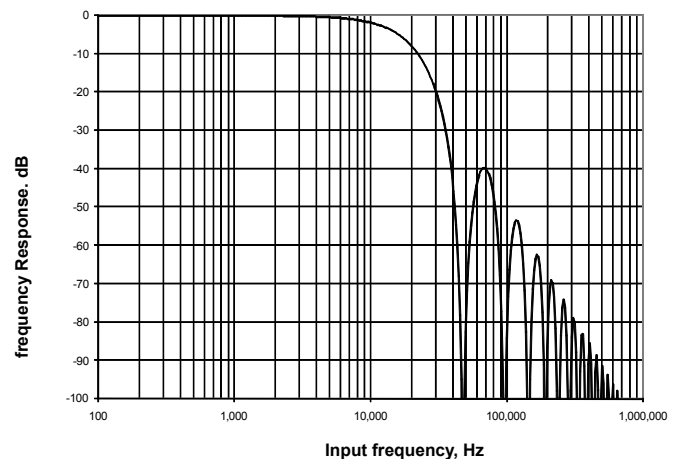


Figure 8-5. Delta-sigma ADC Frequency Response, Normalized to Output, Sample Rate = 48 kHz



Resolution and sample rate are controlled by the Decimator. Data is pipelined in the decimator; the output is a function of the last four samples. When the input multiplexer is switched, the output data is not valid until after the fourth sample after the switch.

### 8.2.2 Operational Modes

The ADC can be configured by the user to operate in one of four modes: Single Sample, Multi Sample, Continuous, or Multi Sample (Turbo). All four modes are started by either a write to the start bit in a control register or an assertion of the Start of Conversion (SoC) signal. When the conversion is complete, a status bit is set and the output signal End of Conversion (EoC) asserts high and remains high until the value is read by either the DMA controller or the CPU.

#### 8.2.2.1 Single Sample

In Single Sample mode, the ADC performs one sample conversion on a trigger. In this mode, the ADC stays in standby state waiting for the SoC signal to be asserted. When SoC is signaled the ADC performs four successive conversions. The first three conversions prime the decimator. The ADC result is valid and available after the fourth conversion, at which time the EoC signal is generated. To detect the end of conversion, the system may poll a control register for status or configure the external EoC signal to generate an interrupt or invoke a DMA request. When the transfer is done the ADC reenters the standby state where it stays until another SoC event.

#### 8.2.2.2 Continuous

Continuous sample mode is used to take multiple successive samples of a single input signal. Multiplexing multiple inputs should not be done with this mode. There is a latency of three conversion times before the first conversion result is available. This is the time required to prime the decimator. After the first result, successive conversions are available at the selected sample rate.

#### 8.2.2.3 Multi Sample

Multi sample mode is similar to continuous mode except that the ADC is reset between samples. This mode is useful when the input is switched between multiple signals. The decimator is re-primed between each sample so that previous samples do not affect the current conversion. Upon completion of a sample, the next sample is automatically initiated. The results can be transferred using either firmware polling, interrupt, or DMA.

More information on output formats is provided in the Technical Reference Manual.

#### 8.2.3 Start of Conversion Input

The SoC signal is used to start an ADC conversion. A digital clock or UDB output can be used to drive this input. It can be used when the sampling period must be longer than the ADC conversion time or when the ADC must be synchronized to other hardware. This signal is optional and does not need to be connected if ADC is running in a continuous mode.

#### 8.2.4 End of Conversion Output

The EoC signal goes high at the end of each ADC conversion. This signal may be used to trigger either an interrupt or DMA request.

### 8.3 Comparators

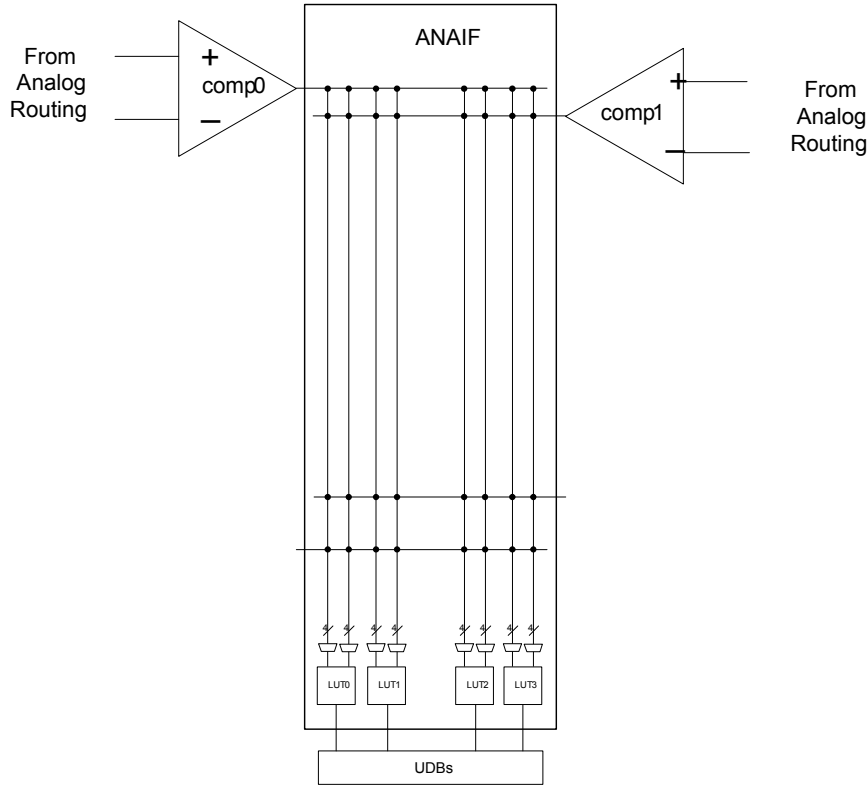
The CY8C32 family of devices contains two comparators in a device. Comparators have these features:

- Input offset factory trimmed to less than 5 mV
- Rail-to-rail common mode input range ( $V_{SSA}$  to  $V_{DDA}$ )
- Speed and power can be traded off by using one of three modes: fast, slow, or ultra low-power
- Comparator outputs can be routed to lookup tables to perform simple logic functions and then can also be routed to digital blocks
- The positive input of the comparators may be optionally passed through a low pass filter. Two filters are provided
- Comparator inputs can be connections to GPIO or DAC output

#### 8.3.1 Input and Output Interface

The positive and negative inputs to the comparators come from the analog global buses, the analog mux line, the analog local bus and precision reference through multiplexers. The output from each comparator could be routed to any of the two input LUTs. The output of that LUT is routed to the UDB Digital System Interface.

**Figure 8-6. Analog Comparator**



**8.3.2 LUT**

The CY8C32 family of devices contains four LUTs. The LUT is a two input, one output lookup table that is driven by any one or two of the comparators in the chip. The output of any LUT is routed to the digital system interface of the UDB array. From the digital system interface of the UDB array, these signals can be connected to UDBs, DMA controller, I/O, or the interrupt controller.

The LUT control word written to a register sets the logic function on the output. The available LUT functions and the associated control word is shown in [Table 8-2](#).

**Table 8-2. LUT Function vs. Program Word and Inputs**

Control Word	Output (A and B are LUT inputs)
0000b	<b>FALSE ('0')</b>
0001b	<b>A AND B</b>
0010b	<b>A AND (NOT B)</b>
0011b	<b>A</b>
0100b	<b>(NOT A) AND B</b>
0101b	<b>B</b>
0110b	<b>A XOR B</b>
0111b	<b>A OR B</b>
1000b	<b>A NOR B</b>
1001b	<b>A XNOR B</b>
1010b	<b>NOT B</b>
1011b	<b>A OR (NOT B)</b>
1100b	<b>NOT A</b>
1101b	<b>(NOT A) OR B</b>
1110b	<b>A NAND B</b>
1111b	<b>TRUE ('1')</b>



### 8.4 LCD Direct Drive

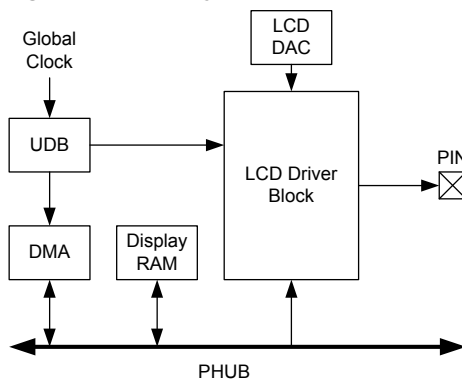
The PSoC Liquid Crystal Display (LCD) driver system is a highly configurable peripheral designed to allow PSoC to directly drive a broad range of LCD glass. All voltages are generated on chip, eliminating the need for external components. With a high multiplex ratio of up to 1/16, the CY8C32 family LCD driver system can drive a maximum of 736 segments. The PSoC LCD driver module was also designed with the conservative power budget of portable devices in mind, enabling different LCD drive modes and power down modes to conserve power.

PSoC Creator provides an LCD segment drive component. The component wizard provides easy and flexible configuration of LCD resources. You can specify pins for segments and commons along with other options. The software configures the device to meet the required specifications. This is possible because of the programmability inherent to PSoC devices.

Key features of the PSoC LCD segment system are:

- LCD panel direct driving
- Type A (standard) and Type B (low-power) waveform support
- Wide operating voltage range support (2 V to 5 V) for LCD panels
- Static, 1/2, 1/3, 1/4, 1/5 bias voltage levels
- Internal bias voltage generation through internal resistor ladder
- Up to 62 total common and segment outputs
- Up to 1/16 multiplex for a maximum of 16 backplane/common outputs
- Up to 62 front plane/segment outputs for direct drive
- Drives up to 736 total segments (16 backplane × 46 front plane)
- Up to 64 levels of software controlled contrast
- Ability to move display data from memory buffer to LCD driver through DMA (without CPU intervention)
- Adjustable LCD refresh rate from 10 Hz to 150 Hz
- Ability to invert LCD display for negative image
- Three LCD driver drive modes, allowing power optimization

**Figure 8-7. LCD System**



#### 8.4.1 LCD Segment Pin Driver

Each GPIO pin contains an LCD driver circuit. The LCD driver buffers the appropriate output of the LCD DAC to directly drive the glass of the LCD. A register setting determines whether the pin is a common or segment. The pin's LCD driver then selects one of the six bias voltages to drive the I/O pin, as appropriate for the display data.

#### 8.4.2 Display Data Flow

The LCD segment driver system reads display data and generates the proper output voltages to the LCD glass to produce the desired image. Display data resides in a memory buffer in the system SRAM. Each time you need to change the common and segment driver voltages, the next set of pixel data moves from the memory buffer into the Port Data Registers via DMA.

#### 8.4.3 UDB and LCD Segment Control

A UDB is configured to generate the global LCD control signals and clocking. This set of signals is routed to each LCD pin driver through a set of dedicated LCD global routing channels. In addition to generating the global LCD control signals, the UDB also produces a DMA request to initiate the transfer of the next frame of LCD data.

#### 8.4.4 LCD DAC

The LCD DAC generates the contrast control and bias voltage for the LCD system. The LCD DAC produces up to five LCD drive voltages plus ground, based on the selected bias ratio. The bias voltages are driven out to GPIO pins on a dedicated LCD bias bus, as required.

### 8.5 CapSense

The CapSense system provides a versatile and efficient means for measuring capacitance in applications such as touch sense buttons, sliders, proximity detection, etc. The CapSense system uses a configuration of system resources, including a few hardware functions primarily targeted for CapSense. Specific resource usage is detailed in each CapSense component in PSoC Creator.

A capacitive sensing method using a delta-sigma modulator (CSD) is used. It provides capacitance sensing using a switched capacitor technique with a delta-sigma modulator to convert the sensing current to a digital code.

### 8.6 Temp Sensor

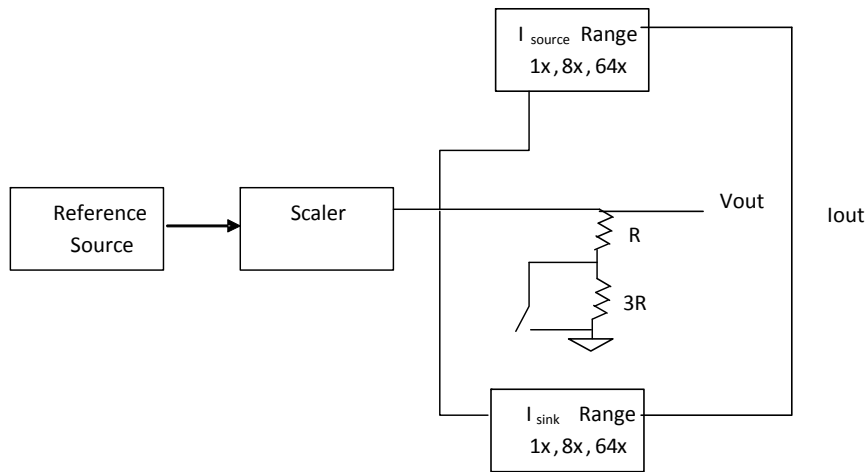
Die temperature is used to establish programming parameters for writing flash. Die temperature is measured using a dedicated sensor based on a forward biased transistor. The temperature sensor has its own auxiliary ADC.

### 8.7 DAC

The CY8C32 parts contain a Digital to Analog Converter (DAC). The DAC is 8-bit and can be configured for either voltage or current output. The DAC supports CapSense, power supply regulation, and waveform generation. The DAC has the following features:

- Adjustable voltage or current output in 255 steps
- Programmable step size (range selection)
- Eight bits of calibration to correct  $\pm 25$  percent of gain error
- Source and sink option for current output
- 8 Msps conversion rate for current output
- 1 Msps conversion rate for voltage output
- Monotonic in nature
- Data and strobe inputs can be provided by the CPU or DMA, or routed directly from the DSI
- Dedicated low-resistance output pin for high-current mode

**Figure 8-8. DAC Block Diagram**



#### 8.7.1 Current DAC

The current DAC (IDAC) can be configured for the ranges 0 to 32  $\mu$ A, 0 to 256  $\mu$ A, and 0 to 2.048 mA. The IDAC can be configured to source or sink current.

#### 8.7.2 Voltage DAC

For the voltage DAC (VDAC), the current DAC output is routed through resistors. The two ranges available for the VDACC are 0 to 1.024 V and 0 to 4.096 V. In voltage mode any load connected to the output of a DAC should be purely capacitive (the output of the VDACC is not buffered).

## 9. Programming, Debug Interfaces, Resources

PSoC devices include extensive support for programming, testing, debugging, and tracing both hardware and firmware. Three interfaces are available: JTAG, SWD, and SWV. JTAG and SWD support all programming and debug features of the device. JTAG also supports standard JTAG scan chains for board level test and chaining multiple JTAG devices to a single JTAG connection.

For more information on PSoC 3 Programming, refer to the application note [AN62391 - In-System Programming for PSoC<sup>®</sup> 3](#).

Complete Debug on Chip (DoC) functionality enables full device debugging in the final system using the standard production device. It does not require special interfaces, debugging pods, simulators, or emulators. Only the standard programming connections are required to fully support debug.

The PSoC Creator IDE software provides fully integrated programming and debug support for PSoC devices. The low cost MiniProg3 programmer and debugger is designed to provide full programming and debug support of PSoC devices in conjunction with the PSoC Creator IDE. PSoC JTAG, SWD, and SWV interfaces are fully compatible with industry standard third party tools.

All DOC circuits are disabled by default and can only be enabled in firmware. If not enabled, the only way to reenables them is to erase the entire device, clear flash protection, and reprogram the device with new firmware that enables DOC. Disabling DOC features, robust flash protection, and hiding custom analog and digital functionality inside the PSoC device provide a level of

security not possible with multichip application solutions. Additionally, all device interfaces can be permanently disabled (Device Security) for applications concerned about phishing attacks due to a maliciously reprogrammed device. Permanently disabling interfaces is not recommended in most applications because you cannot access the device later. Because all programming, debug, and test interfaces are disabled when Device Security is enabled, PSoCs with Device Security enabled may not be returned for failure analysis.

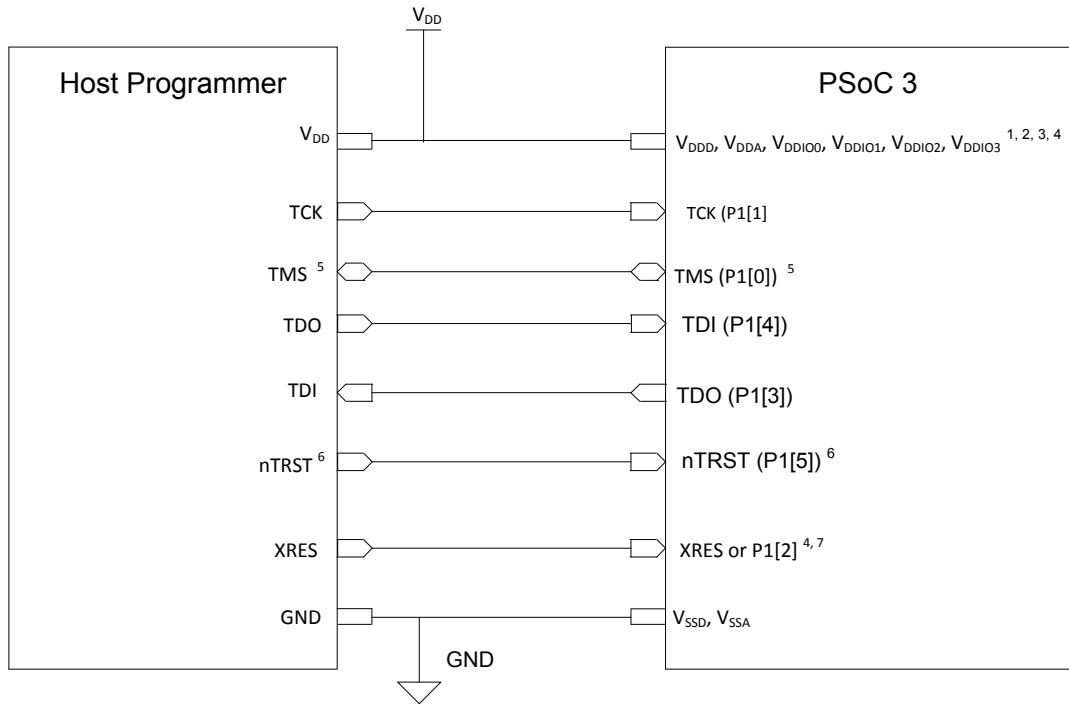
**Table 9-1. Debug Configurations**

Debug and Trace Configuration	GPIO Pins Used
All debug and trace disabled	0
JTAG	4 or 5
SWD	2
SWV	1
SWD + SWV	3

### 9.1 JTAG Interface

The IEEE 1149.1 compliant JTAG interface exists on four or five pins (the nTRST pin is optional). The JTAG clock frequency can be up to 8 MHz, or 1/3 of the CPU clock frequency for 8 and 16-bit transfers, or 1/5 of the CPU clock frequency for 32-bit transfers, whichever is least. By default, the JTAG pins are enabled on new devices but the JTAG interface can be disabled, allowing these pins to be used as General Purpose I/O (GPIO) instead. The JTAG interface is used for programming the flash memory, debugging, I/O scan chains, and JTAG device chaining.

**Figure 9-1. JTAG Interface Connections between PSoC 3 and Programmer**



<sup>1</sup> The voltage levels of Host Programmer and the PSoC 3 voltage domains involved in Programming should be same. The Port 1 JTAG pins, XRES pin (XRES\_N or P1[2]) are powered by V<sub>DDIO1</sub>. So, V<sub>DDIO1</sub> of PSoC 3 should be at same voltage level as host V<sub>DD</sub>. Rest of PSoC 3 voltage domains ( V<sub>DDD</sub>, V<sub>DDA</sub>, V<sub>DDIO0</sub>, V<sub>DDIO2</sub>, V<sub>DDIO3</sub>) need not be at the same voltage level as host Programmer.

<sup>2</sup> V<sub>DDA</sub> must be greater than or equal to all other power supplies (V<sub>DDD</sub>, V<sub>DDIO</sub>'s) in PSoC 3.

<sup>3</sup> For Power cycle mode Programming, XRES pin is not required. But the Host programmer must have the capability to toggle power (V<sub>DDD</sub>, V<sub>DDA</sub>, All V<sub>DDIO</sub>'s) to PSoC 3. This may typically require external interface circuitry to toggle power which will depend on the programming setup. The power supplies can be brought up in any sequence, however, once stable, V<sub>DDA</sub> must be greater than or equal to all other supplies.

<sup>4</sup> For JTAG Programming, Device reset can also be done without connecting to the XRES pin or Power cycle mode by using the TMS, TCK, TDI, TDO pins of PSoC 3, and writing to a specific register. But this requires that the DPS setting in NVL is not equal to "Debug Ports Disabled".

<sup>5</sup> By default, PSoC 3 is configured for 4-wire JTAG mode unless user changes the DPS setting. So the TMS pin is unidirectional. But if the DPS setting is changed to non-JTAG mode, the TMS pin in JTAG is bi-directional as the SWD Protocol has to be used for acquiring the PSoC 3 device initially. After switching from SWD to JTAG mode, the TMS pin will be uni-directional. In such a case, unidirectional buffer should not be used on TMS line.

<sup>6</sup> nTRST JTAG pin (P1[5]) cannot be used to reset the JTAG TAP controller during first time programming of PSoC 3 as the default setting is 4-wire JTAG (nTRST disabled). Use the TMS, TCK pins to do a reset of JTAG TAP controller.

<sup>7</sup> If XRES pin is used by host, P1[2] will be configured as XRES by default only for 48-pin devices (without dedicated XRES pin). For devices with dedicated XRES pin, P1[2] is GPIO pin by default. So use P1[2] as Reset pin only for 48-pin devices, but use dedicated XRES pin for rest of devices.

### 9.2 Serial Wire Debug Interface

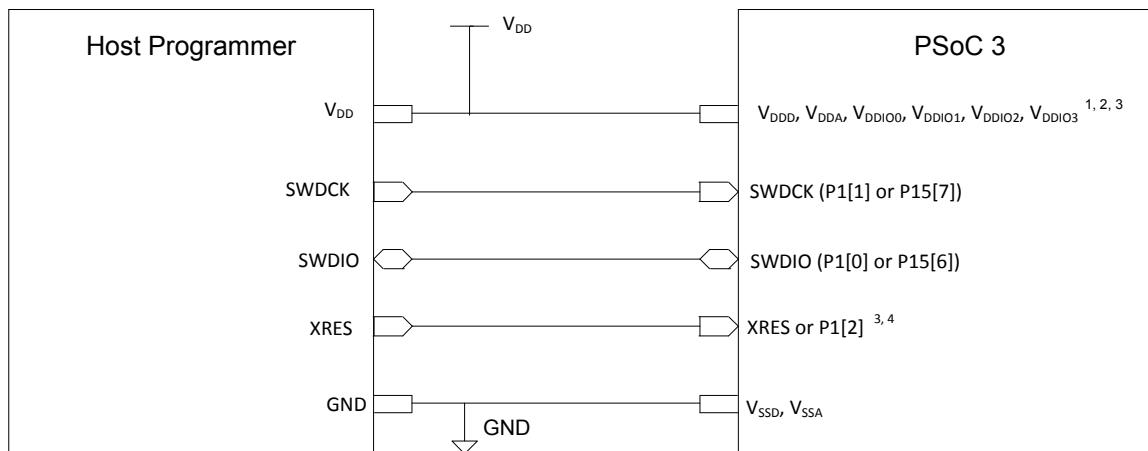
The SWD interface is the preferred alternative to the JTAG interface. It requires only two pins instead of the four or five needed by JTAG. SWD provides all of the programming and debugging features of JTAG at the same speed. SWD does not provide access to scan chains or device chaining. The SWD clock frequency can be up to 1/3 of the CPU clock frequency.

SWD uses two pins, either two of the JTAG pins (TMS and TCK) or the USBIO D+ and D- pins. The USBIO pins are useful for in system programming of USB solutions that would otherwise require a separate programming connector. One pin is used for the data clock and the other is used for data input and output.

SWD can be enabled on only one of the pin pairs at a time. This only happens if, within 8  $\mu$ s (key window) after reset, that pin pair (JTAG or USB) receives a predetermined sequence of 1s and 0s. SWD is used for debugging or programming the flash memory.

The SWD interface can be enabled from the JTAG interface or disabled, allowing its pins to be used as GPIO. Unlike JTAG, the SWD interface can always be reacquired on any device during the key window. It can then be used to reenables the JTAG interface, if desired. When using SWD or JTAG pins as standard GPIO, make sure that the GPIO functionality and PCB circuits do not interfere with SWD or JTAG use.

**Figure 9-2. SWD Interface Connections between PSoC 3 and Programmer**



<sup>1</sup> The voltage levels of the Host Programmer and the PSoC 3 voltage domains involved in Programming should be the same. XRES pin (XRES\_N or P1[2]) is powered by  $V_{DDIO1}$ . The USB SWD pins are powered by  $V_{DD}$ . So for Programming using the USB SWD pins with XRES pin, the  $V_{DD}$ ,  $V_{DDIO1}$  of PSoC 3 should be at the same voltage level as Host  $V_{DD}$ . Rest of PSoC 3 voltage domains ( $V_{DDA}$ ,  $V_{DDIO0}$ ,  $V_{DDIO2}$ ,  $V_{DDIO3}$ ) need not be at the same voltage level as host Programmer. The Port 1 SWD pins are powered by  $V_{DDIO1}$ . So  $V_{DDIO1}$  of PSoC 3 should be at same voltage level as host  $V_{DD}$  for Port 1 SWD programming. Rest of PSoC 3 voltage domains ( $V_{DD}$ ,  $V_{DDA}$ ,  $V_{DDIO0}$ ,  $V_{DDIO2}$ ,  $V_{DDIO3}$ ) need not be at the same voltage level as host Programmer.

<sup>2</sup>  $V_{DDA}$  must be greater than or equal to all other power supplies ( $V_{DD}$ ,  $V_{DDIO}$ 's) in PSoC 3.

<sup>3</sup> For Power cycle mode Programming, XRES pin is not required. But the Host programmer must have the capability to toggle power ( $V_{DD}$ ,  $V_{DDA}$ , All  $V_{DDIO}$ 's) to PSoC 3. This may typically require external interface circuitry to toggle power which will depend on the programming setup. The power supplies can be brought up in any sequence, however, once stable,  $V_{DDA}$  must be greater than or equal to all other supplies.

<sup>4</sup> P1[2] will be configured as XRES by default only for 48-pin devices (without dedicated XRES pin). For devices with dedicated XRES pin, P1[2] is GPIO pin by default. So use P1[2] as Reset pin only for 48-pin devices, but use dedicated XRES pin for rest of devices.

### 9.3 Debug Features

Using the JTAG or SWD interface, the CY8C32 supports the following debug features:

- Halt and single-step the CPU
- View and change CPU and peripheral registers, and RAM addresses
- Eight program address breakpoints
- One memory access breakpoint—break on reading or writing any memory address and data value
- Break on a sequence of breakpoints (non recursive)
- Debugging at the full speed of the CPU
- Debug operations are possible while the device is reset, or in low-power modes
- Compatible with PSoC Creator and MiniProg3 programmer and debugger
- Standard JTAG programming and debugging interfaces make CY8C32 compatible with other popular third-party tools (for example, ARM / Keil)

### 9.4 Trace Features

The CY8C32 supports the following trace features when using JTAG or SWD:

- Trace the 8051 program counter (PC), accumulator register (ACC), and one SFR / 8051 core RAM register
- Trace depth up to 1000 instructions if all registers are traced, or 2000 instructions if only the PC is traced (on devices that include trace memory)
- Program address trigger to start tracing
- Trace windowing, that is, only trace when the PC is within a given range
- Two modes for handling trace buffer full: continuous (overwriting the oldest trace data) or break when trace buffer is full

### 9.5 Single Wire Viewer Interface

The SWV interface is closely associated with SWD but can also be used independently. SWV data is output on the JTAG interface's TDO pin. If using SWV, you must configure the device for SWD, not JTAG. SWV is not supported with the JTAG interface.

SWV is ideal for application debug where it is helpful for the firmware to output data similar to 'printf' debugging on PCs. The SWV is ideal for data monitoring, because it requires only a single pin and can output data in standard UART format or Manchester encoded format. For example, it can be used to tune a PID control loop in which the output and graphing of the three error terms greatly simplifies coefficient tuning.

The following features are supported in SWV:

- 32 virtual channels, each 32 bits long
- Simple, efficient packing and serializing protocol
- Supports standard UART format (N81)

### 9.6 Programming Features

The JTAG and SWD interfaces provide full programming support. The entire device can be erased, programmed, and

verified. You can increase flash protection levels to protect firmware IP. Flash protection can only be reset after a full device erase. Individual flash blocks can be erased, programmed, and verified, if block security settings permit.

### 9.7 Device Security

PSoC 3 offers an advanced security feature called device security, which permanently disables all test, programming, and debug ports, protecting your application from external access. The device security is activated by programming a 32-bit key (0x50536F43) to a Write Once Latch (WOL).

The Write Once Latch is a type of nonvolatile latch (NVL). The cell itself is an NVL with additional logic wrapped around it. Each WOL device contains four bytes (32 bits) of data. The wrapper outputs a '1' if a super-majority (28 of 32) of its bits match a pre-determined pattern (0x50536F43); it outputs a '0' if this majority is not reached. When the output is 1, the Write Once NV latch locks the part out of Debug and Test modes; it also permanently gates off the ability to erase or alter the contents of the latch. Matching all bits is intentionally not required, so that single (or few) bit failures do not deassert the WOL output. The state of the NVL bits after wafer processing is truly random with no tendency toward 1 or 0.

The WOL only locks the part after the correct 32-bit key (0x50536F43) is loaded into the NVL's volatile memory, programmed into the NVL's nonvolatile cells, and the part is reset. The output of the WOL is only sampled on reset and used to disable the access. This precaution prevents anyone from reading, erasing, or altering the contents of the internal memory.

The user can write the key into the WOL to lock out external access only if no flash protection is set (see "Flash Security" on page 22). However, after setting the values in the WOL, a user still has access to the part until it is reset. Therefore, a user can write the key into the WOL, program the flash protection data, and then reset the part to lock it.

If the device is protected with a WOL setting, Cypress cannot perform failure analysis and, therefore, cannot accept RMAs from customers. The WOL can be read out via SWD port to electrically identify protected parts. The user can write the key in WOL to lock out external access only if no flash protection is set. For more information on how to take full advantage of the security features in PSoC see the PSoC 3 TRM.

#### Disclaimer

Note the following details of the flash code protection features on Cypress devices.

Cypress products meet the specifications contained in their particular Cypress datasheets. Cypress believes that its family of products is one of the most secure families of its kind on the market today, regardless of how they are used. There may be methods, unknown to Cypress, that can breach the code protection features. Any of these methods, to our knowledge, would be dishonest and possibly illegal. Neither Cypress nor any other semiconductor manufacturer can guarantee the security of their code. Code protection does not mean that we are guaranteeing the product as "unbreakable."

Cypress is willing to work with the customer who is concerned about the integrity of their code. Code protection is constantly evolving. We at Cypress are committed to continuously improving the code protection features of our products.

## 10. Development Support

The CY8C32 family has a rich set of documentation, development tools, and online resources to assist you during your development process. Visit [psoc.cypress.com/getting-started](http://psoc.cypress.com/getting-started) to find out more.

### 10.1 Documentation

A suite of documentation, supports the CY8C32 family to ensure that you can find answers to your questions quickly. This section contains a list of some of the key documents.

**Software User Guide:** A step-by-step guide for using PSoC Creator. The software user guide shows you how the PSoC Creator build process works in detail, how to use source control with PSoC Creator, and much more.

**Component Datasheets:** The flexibility of PSoC allows the creation of new peripherals (components) long after the device has gone into production. Component datasheets provide all of the information needed to select and use a particular component, including a functional description, API documentation, example code, and AC/DC specifications.

**Application Notes:** PSoC application notes discuss a particular application of PSoC in depth; examples include brushless DC motor control and on-chip filtering. Application notes often include example projects in addition to the application note document.

**Technical Reference Manual:** The Technical Reference Manual (TRM) contains all the technical detail you need to use a PSoC device, including a complete description of all PSoC registers.

### 10.2 Online

In addition to print documentation, the Cypress PSoC forums connect you with fellow PSoC users and experts in PSoC from around the world, 24 hours a day, 7 days a week.

### 10.3 Tools

With industry standard cores, programming, and debugging interfaces, the CY8C32 family is part of a development tool ecosystem. Visit us at [www.cypress.com/go/psoccreator](http://www.cypress.com/go/psoccreator) for the latest information on the revolutionary, easy to use PSoC Creator IDE, supported third party compilers, programmers, debuggers, and development kits.

## 11. Electrical Specifications

Specifications are valid for  $-40\text{ }^{\circ}\text{C} \leq T_A \leq 85\text{ }^{\circ}\text{C}$  and  $T_J \leq 100\text{ }^{\circ}\text{C}$ , except where noted. Specifications are valid for 1.71 V to 5.5 V, except where noted. The unique flexibility of the PSoC UDBs and analog blocks enable many functions to be implemented in PSoC Creator components, see the component datasheets for full AC/DC specifications of individual functions. See the “[Example Peripherals](#)” section on page 41 for further explanation of PSoC Creator components.

### 11.1 Absolute Maximum Ratings

**Table 11-1. Absolute Maximum Ratings DC Specifications**

Parameter	Description	Conditions	Min	Typ	Max	Units
$T_{STG}$	Storage temperature	Higher storage temperatures reduce NVL data retention time. Recommended storage temperature is $+25\text{ }^{\circ}\text{C} \pm 25\text{ }^{\circ}\text{C}$ . Extended duration storage temperatures above $85\text{ }^{\circ}\text{C}$ degrade reliability.	-55	25	100	$^{\circ}\text{C}$
$V_{DDA}$	Analog supply voltage relative to $V_{SSA}$		-0.5	-	6	V
$V_{DDD}$	Digital supply voltage relative to $V_{SSD}$		-0.5	-	6	V
$V_{DDIO}$	I/O supply voltage relative to $V_{SSD}$		-0.5	-	6	V
$V_{CCA}$	Direct analog core voltage input		-0.5	-	1.95	V
$V_{CCD}$	Direct digital core voltage input		-0.5	-	1.95	V
$V_{SSA}$	Analog ground voltage		$V_{SSD} - 0.5$	-	$V_{SSD} + 0.5$	V
$V_{GPIO}^{[14]}$	DC input voltage on GPIO	Includes signals sourced by $V_{DDA}$ and routed internal to the pin	$V_{SSD} - 0.5$	-	$V_{DDIO} + 0.5$	V
$V_{SIO}$	DC input voltage on SIO	Output disabled	$V_{SSD} - 0.5$	-	7	V
		Output enabled	$V_{SSD} - 0.5$	-	6	V
$V_{IND}$	Voltage at boost converter input		0.5	-	5.5	V
$V_{BAT}$	Boost converter supply		$V_{SSD} - 0.5$	-	5.5	V
$I_{VDDIO}$	Current per $V_{DDIO}$ supply pin		-	-	100	mA
$V_{extref}$	ADC external reference inputs	Pins P0[3], P3[2]	-	-	2	V
LU	Latch up current <sup>[15]</sup>		-140	-	140	mA
$ESD_{HBM}$	Electrostatic discharge voltage	Human body model	750	-	-	V
$ESD_{CDM}$	Electrostatic discharge voltage	Charge device model	500	-	-	V

**Note** Usage above the absolute maximum conditions listed in [Table 11-1](#) may cause permanent damage to the device. Exposure to maximum conditions for extended periods of time may affect device reliability. When used below maximum conditions but above normal operating conditions the device may not operate to specification.

#### Notes

14. The  $V_{DDIO}$  supply voltage must be greater than the maximum analog voltage on the associated GPIO pins. Maximum analog voltage on GPIO pin  $\leq V_{DDIO} \leq V_{DDA}$ .

15. Meets or exceeds JEDEC Spec EIA/JESD78 IC Latch-up Test.



## 11.2 Device Level Specifications

Specifications are valid for  $-40\text{ }^{\circ}\text{C} \leq T_A \leq 85\text{ }^{\circ}\text{C}$  and  $T_J \leq 100\text{ }^{\circ}\text{C}$ , except where noted. Specifications are valid for 1.71 V to 5.5 V, except where noted.

### 11.2.1 Device Level Specifications

**Table 11-2. DC Specifications**

Parameter	Description	Conditions	Min	Typ	Max	Units	
V <sub>DDA</sub>	Analog supply voltage and input to analog core regulator	Analog core regulator enabled	1.8	–	5.5	V	
V <sub>DDA</sub>	Analog supply voltage, analog regulator bypassed	Analog core regulator disabled	1.71	1.8	1.89	V	
V <sub>DDD</sub>	Digital supply voltage relative to V <sub>SSD</sub>	Digital core regulator enabled	1.8	–	V <sub>DDA</sub> <sup>[16]</sup>	V	
V <sub>DDD</sub>	Digital supply voltage, digital regulator bypassed	Digital core regulator disabled	1.71	1.8	1.89	V	
V <sub>DDIO</sub> <sup>[17]</sup>	I/O supply voltage relative to V <sub>SSIO</sub>		1.71	–	V <sub>DDA</sub> <sup>[16]</sup>	V	
V <sub>CCA</sub>	Direct analog core voltage input (Analog regulator bypass)	Analog core regulator disabled	1.71	1.8	1.89	V	
V <sub>CCD</sub>	Direct digital core voltage input (Digital regulator bypass)	Digital core regulator disabled	1.71	1.8	1.89	V	
I <sub>DD</sub> <sup>[18]</sup>	<b>Active Mode, V<sub>DD</sub> = 1.71 V–5.5 V</b>						
	Bus clock off. Execute from CPU instruction buffer. See “Flash Program Memory” on page 22.	CPU at 3 MHz	T = –40 °C	–	–	–	mA
			T = 25 °C	–	0.8	–	mA
			T = 85 °C	–	–	–	mA
		CPU at 6 MHz	T = –40 °C	–	–	–	mA
			T = 25 °C	–	1.2	–	mA
			T = 85 °C	–	–	–	mA
		CPU at 12 MHz	T = –40 °C	–	–	–	mA
			T = 25 °C	–	2.0	–	mA
			T = 85 °C	–	–	–	mA
		CPU at 24 MHz	T = –40 °C	–	–	–	mA
			T = 25 °C	–	3.5	–	mA
			T = 85 °C	–	–	–	mA
		CPU at 48 MHz	T = –40 °C	–	–	–	mA
			T = 25 °C	–	6.6	–	mA
			T = 85 °C	–	–	–	mA
V <sub>DD</sub> = 3.3 V, T = 25 °C, IMO and bus clock enabled, ILO = 1 kHz, CPU executing from flash and accessing SRAM, all other blocks off, all I/Os tied low.	CPU at 3 MHz	–	1.4	–	mA		
	CPU at 6 MHz	–	2.2	–	mA		
	CPU at 12 MHz	–	3.6	–	mA		
	CPU at 24 MHz	–	6.4	–	mA		
	CPU at 48 MHz	–	11.8	–	mA		

#### Notes

16. The power supplies can be brought up in any sequence however once stable V<sub>DDA</sub> must be greater than or equal to all other supplies.
17. The V<sub>DDIO</sub> supply voltage must be greater than the maximum analog voltage on the associated GPIO pins. Maximum analog voltage on GPIO pin  $\leq V_{DDIO} \leq V_{DDA}$ .
18. The current consumption of additional peripherals that are implemented only in programmed logic blocks can be found in their respective datasheets, available in PSoC Creator, the integrated design environment. To estimate total current, find CPU current at frequency of interest and add peripheral currents for your particular system from the device datasheet and component datasheets.

**Table 11-2. DC Specifications (continued)**

Parameter	Description	Conditions	Min	Typ	Max	Units		
<b>Sleep Mode<sup>[20]</sup></b>								
	CPU = OFF RTC = ON (= ECO32K ON, in low-power mode) Sleep timer = ON (= ILO ON at 1 kHz) <sup>[21]</sup> WDT = OFF I <sup>2</sup> C Wake = OFF Comparator = OFF POR = ON Boost = OFF SIO pins in single ended input, unregulated output mode	$V_{DD} = V_{DDIO} = 4.5-5.5\text{ V}$	T = -40 °C	-	-	-	μA	
			T = 25 °C	-	-	-	μA	
			T = 85 °C	-	-	-	μA	
		$V_{DD} = V_{DDIO} = 2.7-3.6\text{ V}$	T = -40 °C	-	-	-	μA	
			T = 25 °C	-	1	-	μA	
			T = 85 °C	-	-	-	μA	
		$V_{DD} = V_{DDIO} = 1.71-1.95\text{ V}$	T = -40 °C	-	-	-	μA	
			T = 25 °C	-	-	-	μA	
			T = 85 °C	-	-	-	μA	
	Comparator = ON CPU = OFF RTC = OFF Sleep timer = OFF WDT = OFF I <sup>2</sup> C Wake = OFF POR = ON Boost = OFF SIO pins in single ended input, unregulated output mode	$V_{DD} = V_{DDIO} = 2.7-3.6\text{ V}$	T = 25 °C	-	-	-	μA	
	I <sup>2</sup> C Wake = ON CPU = OFF RTC = OFF Sleep timer = OFF WDT = OFF Comparator = OFF POR = ON Boost = OFF SIO pins in single ended input, unregulated output mode	$V_{DD} = V_{DDIO} = 2.7-3.6\text{ V}$	T = 25 °C	-	-	-	μA	
<b>Hibernate Mode<sup>[20]</sup></b>								
	Hibernate mode current All regulators and oscillators off. SRAM retention GPIO interrupts are active Boost = OFF SIO pins in single ended input, unregulated output mode	$V_{DD} = V_{DDIO} = 4.5-5.5\text{ V}$	T = -40 °C	-	-	-	nA	
			T = 25 °C	-	-	-	nA	
			T = 85 °C	-	-	-	nA	
			$V_{DD} = V_{DDIO} = 2.7-3.6\text{ V}$	T = -40 °C	-	-	-	nA
				T = 25 °C	-	200	-	nA
				T = 85 °C	-	-	-	nA
			$V_{DD} = V_{DDIO} = 1.71-1.95\text{ V}$	T = -40 °C	-	-	-	nA
				T = 25 °C	-	-	-	nA
				T = 85 °C	-	-	-	nA

**Notes**

- 19. The current consumption of additional peripherals that are implemented only in programmed logic blocks can be found in their respective datasheets, available in PSoC Creator, the integrated design environment. To compute total current, find CPU current at frequency of interest and add peripheral currents for your particular system from the device datasheet and component datasheets.
- 20. If  $V_{CCD}$  and  $V_{CCA}$  are externally regulated, the voltage difference between  $V_{CCD}$  and  $V_{CCA}$  must be less than 50 mV.
- 21. Sleep timer generates periodic interrupts to wake up the CPU. This specification applies only to those times that the CPU is off.

Figure 11-1. Active Mode Current vs  $F_{CPU}$ ,  $V_{DD} = 3.3\text{ V}$ , Temperature =  $25\text{ }^{\circ}\text{C}$

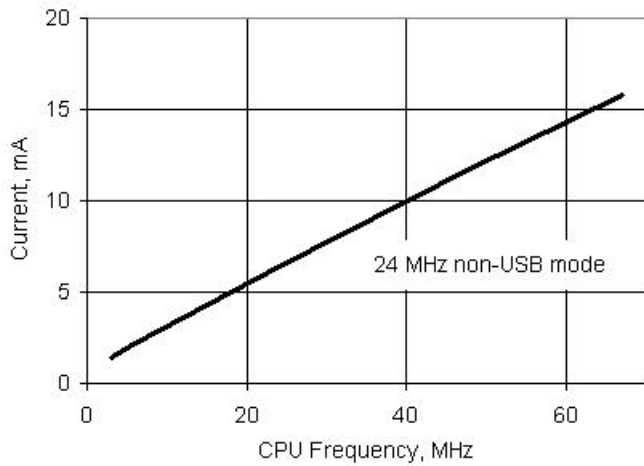


Figure 11-2. Active Mode Current vs Temperature and  $F_{CPU}$ ,  $V_{DD} = 3.3\text{ V}$

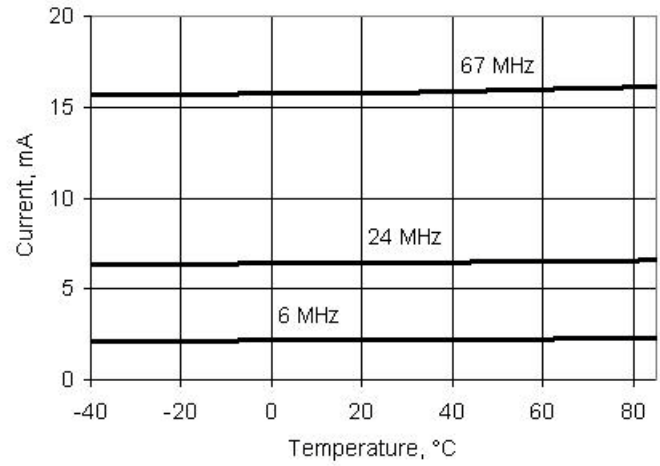
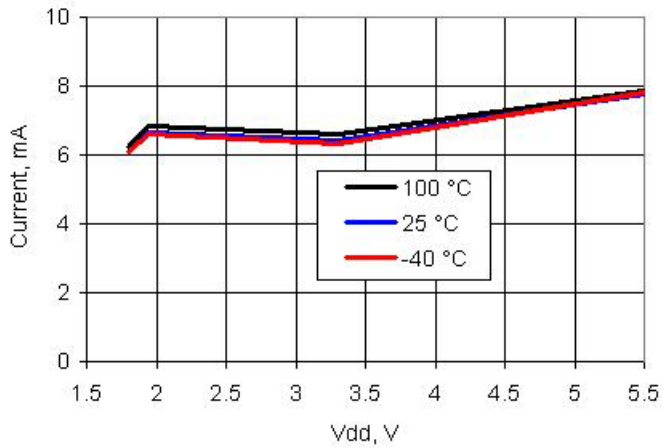


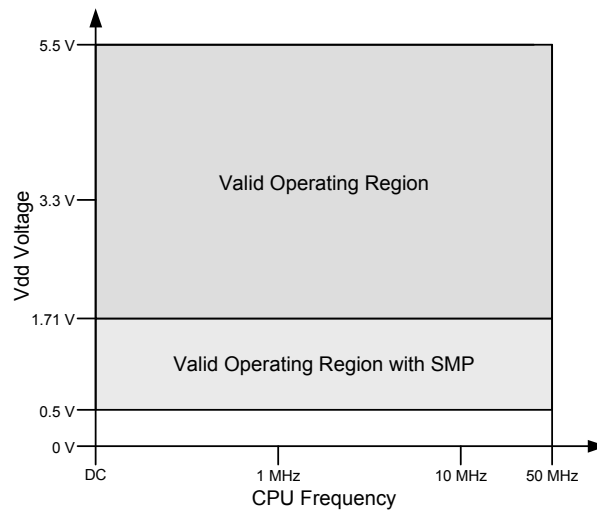
Figure 11-3. Active Mode Current vs  $V_{DD}$  and Temperature,  $F_{CPU} = 24\text{ MHz}$



**Table 11-3. AC Specifications<sup>[22]</sup>**

Parameter	Description	Conditions	Min	Typ	Max	Units
F <sub>CPU</sub>	CPU frequency	1.71 V ≤ V <sub>DDD</sub> ≤ 5.5 V	DC	–	50.01	MHz
F <sub>BUSCLK</sub>	Bus frequency	1.71 V ≤ V <sub>DDD</sub> ≤ 5.5 V	DC	–	50.01	MHz
Sv <sub>dd</sub>	V <sub>DD</sub> ramp rate		–	–	1	V/ns
T <sub>IO_INIT</sub>	Time from V <sub>DDD</sub> /V <sub>DDA</sub> /V <sub>CCD</sub> /V <sub>CCA</sub> ≥ IPOR to I/O ports set to their reset states		–	–	10	μs
T <sub>STARTUP</sub>	Time from V <sub>DDD</sub> /V <sub>DDA</sub> /V <sub>CCD</sub> /V <sub>CCA</sub> ≥ PRES to CPU executing code at reset vector	V <sub>CCA</sub> /V <sub>CCD</sub> = regulated from V <sub>DDA</sub> /V <sub>DDD</sub> , no PLL used, IMO boot mode (12 MHz typ.)	–	–	66	μs
T <sub>SLEEP</sub>	Wakeup from sleep mode – Application of non-LVD interrupt to beginning of execution of next CPU instruction		–	–	15	μs
T <sub>HIBERNATE</sub>	Wakeup from hibernate mode – Application of external interrupt to beginning of execution of next CPU instruction		–	–	100	μs

**Figure 11-4. F<sub>CPU</sub> vs. V<sub>DD</sub>**



**Note**  
22. Based on device characterization (Not production tested).

### 11.3 Power Regulators

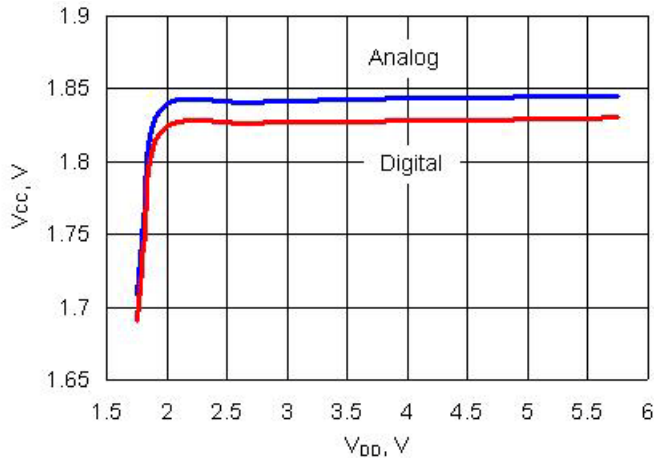
Specifications are valid for  $-40\text{ }^{\circ}\text{C} \leq T_A \leq 85\text{ }^{\circ}\text{C}$  and  $T_J \leq 100\text{ }^{\circ}\text{C}$ , except where noted. Specifications are valid for 1.71 V to 5.5 V, except where noted.

#### 11.3.1 Digital Core Regulator

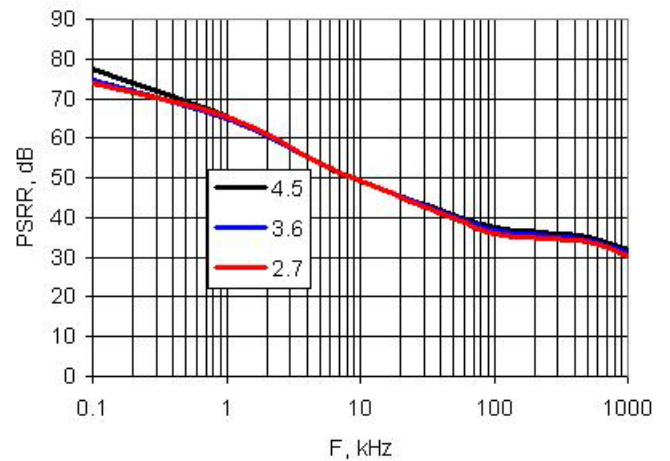
**Table 11-4. Digital Core Regulator DC Specifications**

Parameter	Description	Conditions	Min	Typ	Max	Units
V <sub>DDD</sub>	Input voltage		1.8	–	5.5	V
V <sub>CCD</sub>	Output voltage		–	1.80	–	V
	Regulator output capacitor	±10%, X5R ceramic or better. The two V <sub>CCD</sub> pins must be shorted together, with as short a trace as possible, see <a href="#">Power System</a> on page 29	–	1	–	μF

**Figure 11-5. Regulators V<sub>CC</sub> vs V<sub>DD</sub>**



**Figure 11-6. Digital Regulator PSRR vs Frequency and V<sub>DD</sub>**

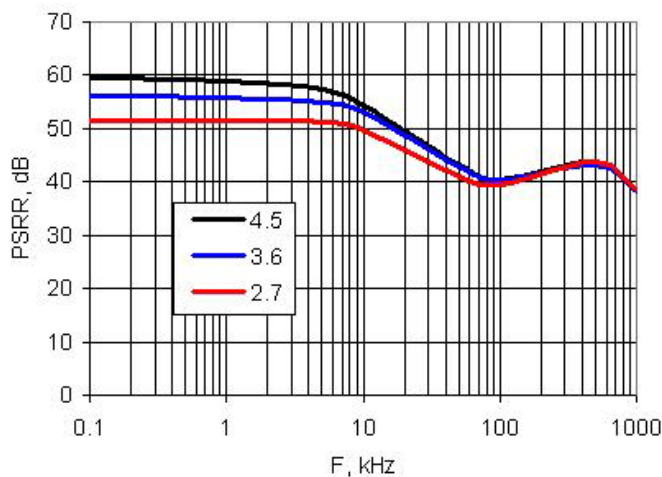


#### 11.3.2 Analog Core Regulator

**Table 11-5. Analog Core Regulator DC Specifications**

Parameter	Description	Conditions	Min	Typ	Max	Units
V <sub>DDA</sub>	Input voltage		1.8	–	5.5	V
V <sub>CCA</sub>	Output voltage		–	1.80	–	V
	Regulator output capacitor	±10%, X5R ceramic or better	–	1	–	μF

**Figure 11-7. Analog Regulator PSRR vs Frequency and V<sub>DD</sub>**



### 11.3.3 Inductive Boost Regulator.

**Table 11-6. Inductive Boost Regulator DC Specifications**

Unless otherwise specified, operating conditions are:  $V_{BAT} = 2.4\text{ V}$ ,  $V_{OUT} = 2.7\text{ V}$ ,  $I_{OUT} = 40\text{ mA}$ ,  $F_{SW} = 400\text{ kHz}$ ,  $L_{BOOST} = 10\text{ }\mu\text{H}$ ,  $C_{BOOST} = 22\text{ }\mu\text{F} \parallel 0.1\text{ }\mu\text{F}$

Parameter	Description	Conditions	Min	Typ	Max	Units
$V_{BAT}$	Input voltage Includes startup	$T = -35\text{ }^{\circ}\text{C}$ to $+65\text{ }^{\circ}\text{C}$	0.5	–	3.6	V
		Over entire temperature range	0.68	–	3.6	V
$I_{OUT}$	Load current <sup>[23, 24]</sup>	$V_{BAT} = 1.6 - 3.6\text{ V}$ , $V_{OUT} = 3.6 - 5.0\text{ V}$ , external diode	–	–	50	mA
		$V_{BAT} = 1.6 - 3.6\text{ V}$ , $V_{OUT} = 1.6 - 3.6\text{ V}$ , internal diode	–	–	75	mA
		$V_{BAT} = 0.8 - 1.6\text{ V}$ , $V_{OUT} = 1.6 - 3.6\text{ V}$ , internal diode	–	–	30	mA
		$V_{BAT} = 0.8 - 1.6\text{ V}$ , $V_{OUT} = 3.6 - 5.0\text{ V}$ , external diode	–	–	20	mA
		$V_{BAT} = 0.5 - 0.8\text{ V}$ , $V_{OUT} = 1.6 - 3.6\text{ V}$ , internal diode	–	–	15	mA
$I_{LPK}$	Inductor peak current		–	–	700	mA
$I_Q$	Quiescent current	Boost active mode	–	200	–	$\mu\text{A}$
		Boost standby mode, 32 khz external crystal oscillator, $I_{OUT} < 1\text{ iA}$	–	12	–	$\mu\text{A}$
$V_{OUT}$	Boost voltage range <sup>[25, 26]</sup>					
	1.8 V		1.71	1.80	1.89	V
	1.9 V		1.81	1.90	2.00	V
	2.0 V		1.90	2.00	2.10	V
	2.4 V		2.28	2.40	2.52	V
	2.7 V		2.57	2.70	2.84	V
	3.0 V		2.85	3.00	3.15	V
	3.3 V		3.14	3.30	3.47	V
	3.6 V		3.42	3.60	3.78	V
5.0 V	External diode required	4.75	5.00	5.25	V	
$Reg_{LOAD}$	Load regulation		–	–	3.8	%
$Reg_{LINE}$	Line regulation		–	–	4.1	%
$\eta$	Efficiency	$L_{BOOST} = 10\text{ }\mu\text{H}$	70	85	–	%
		$L_{BOOST} = 22\text{ }\mu\text{H}$	82	90	–	%

**Notes**

23. For output voltages above 3.6 V, an external diode is required.

24. Maximum output current applies for output voltages  $\leq 4x$  input voltage.

25. Based on device characterization (Not production tested).

26. At boost frequency of 2 MHz,  $V_{OUT}$  is limited to  $2x V_{BAT}$ . At 400 kHz,  $V_{OUT}$  is limited to  $4x V_{BAT}$ .

**Table 11-7. Inductive Boost Regulator AC Specifications**

Unless otherwise specified, operating conditions are:  $V_{BAT} = 2.4\text{ V}$ ,  $V_{OUT} = 2.7\text{ V}$ ,  $I_{OUT} = 40\text{ mA}$ ,  $F_{SW} = 400\text{ kHz}$ ,  $L_{BOOST} = 10\text{ }\mu\text{H}$ ,  $C_{BOOST} = 22\text{ }\mu\text{F} \parallel 0.1\text{ }\mu\text{F}$ .

Parameter	Description	Conditions	Min	Typ	Max	Units
$V_{RIPPLE}$	Ripple voltage (peak-to-peak)	$V_{OUT} = 1.8\text{ V}$ , $F_{SW} = 400\text{ kHz}$ , $I_{OUT} = 10\text{ mA}$	–	–	100	mV
$F_{SW}$	Switching frequency		–	0.1, 0.4, or 2	–	MHz

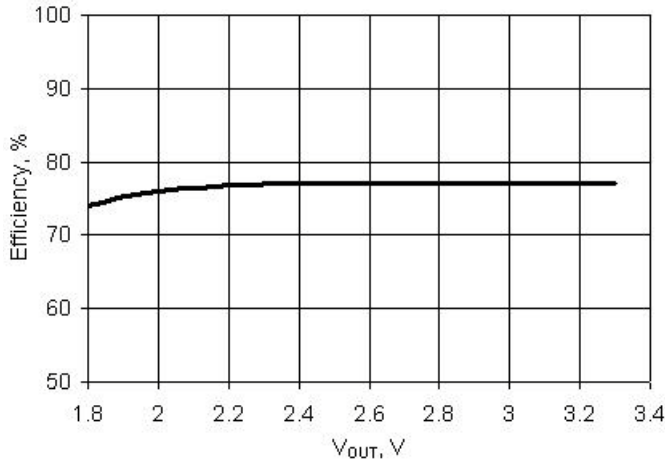
**Table 11-8. Recommended External Components for Boost Circuit**

Parameter	Description	Conditions	Min	Typ	Max	Units
$L_{BOOST}$	Boost inductor		4.7	10	47	$\mu\text{H}$
$C_{BOOST}$	Filter capacitor <sup>[27]</sup>		10	22	47	$\mu\text{F}$
$I_F$	External Schottky diode average forward current	External Schottky diode is required for $V_{OUT} > 3.6\text{ V}$	1	–	–	A
$V_R$			20	–	–	V

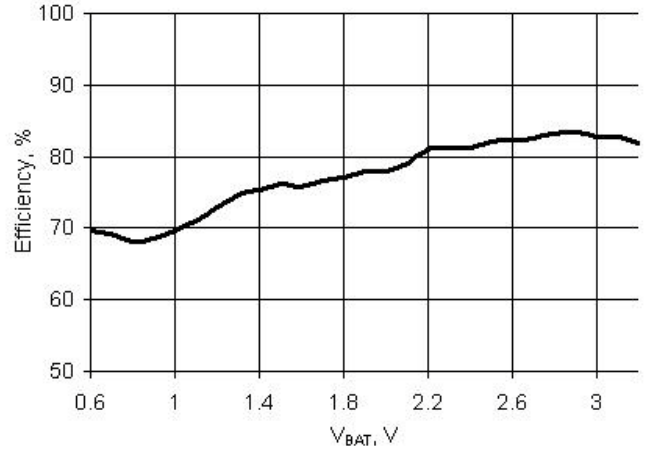
**Note**

27. Based on device characterization (Not production tested).

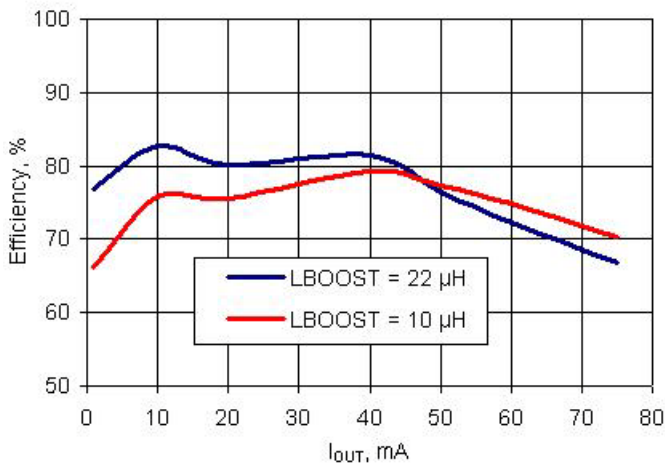
**Figure 11-8. Efficiency vs  $V_{OUT}$**   
 $I_{OUT} = 30\text{ mA}$ ,  $V_{BAT}$  ranges from 0.7 V to  $V_{OUT}$ ,  $L_{BOOST} = 22\text{ }\mu\text{H}$



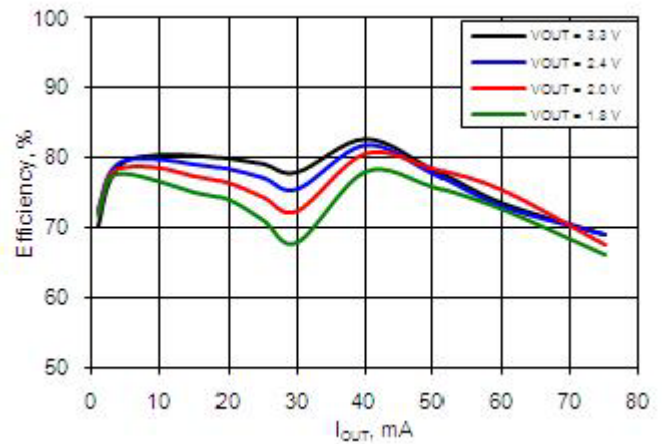
**Figure 11-9. Efficiency vs  $V_{BAT}$**   
 $I_{OUT} = 30\text{ mA}$ ,  $V_{OUT} = 3.3\text{ V}$ ,  $L_{BOOST} = 22\text{ }\mu\text{H}$



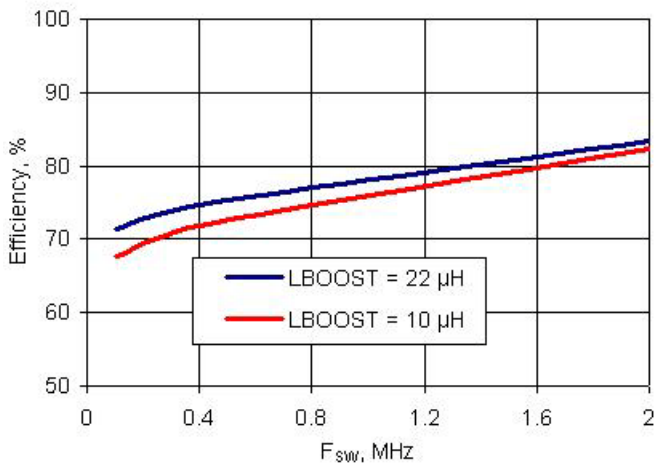
**Figure 11-10. Efficiency vs  $I_{OUT}$**   
 $V_{BAT} = 2.4\text{ V}$ ,  $V_{OUT} = 3.3\text{ V}$



**Figure 11-11. Efficiency vs  $I_{OUT}$**   
 $V_{BAT}$  ranges from 0.7 V to 3.3 V,  $L_{BOOST} = 22\text{ }\mu\text{H}$



**Figure 11-12. Efficiency vs Switching Frequency**  
 $V_{OUT} = 3.3\text{ V}$ ,  $V_{BAT} = 2.4\text{ V}$ ,  $I_{OUT} = 40\text{ mA}$





### 11.1 Inputs and Outputs

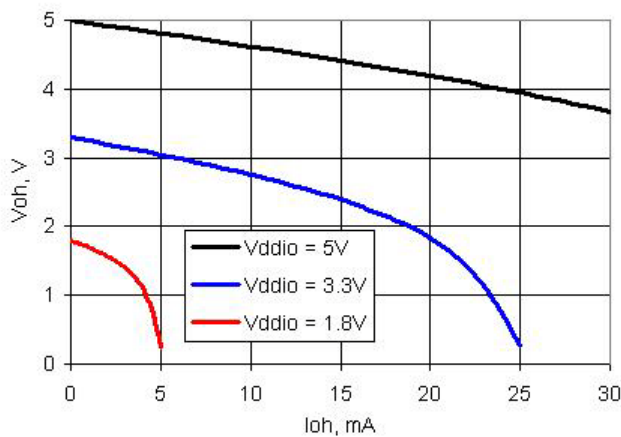
Specifications are valid for  $-40\text{ }^{\circ}\text{C} \leq T_A \leq 85\text{ }^{\circ}\text{C}$  and  $T_J \leq 100\text{ }^{\circ}\text{C}$ , except where noted. Specifications are valid for 1.71 V to 5.5 V, except where noted. Unless otherwise specified, all charts and graphs show typical values.

#### 11.1.1 GPIO

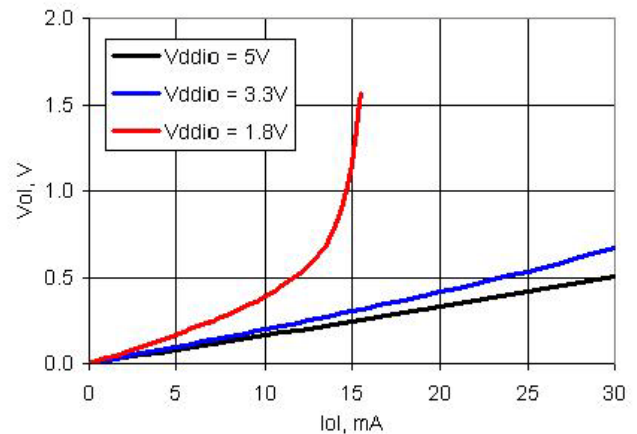
**Table 11-9. GPIO DC Specifications**

Parameter	Description	Conditions	Min	Typ	Max	Units
$V_{IH}$	Input voltage high threshold	CMOS Input, PRT[*]CTL = 0	$0.7 \times V_{DDIO}$	–	–	V
$V_{IL}$	Input voltage low threshold	CMOS Input, PRT[*]CTL = 0	–	–	$0.3 \times V_{DDIO}$	V
$V_{IH}$	Input voltage high threshold	LVTTL Input, PRT[*]CTL = 1, $V_{DDIO} < 2.7\text{ V}$	$0.7 \times V_{DDIO}$	–	–	V
$V_{IH}$	Input voltage high threshold	LVTTL Input, PRT[*]CTL = 1, $V_{DDIO} \geq 2.7\text{ V}$	2.0	–	–	V
$V_{IL}$	Input voltage low threshold	LVTTL Input, PRT[*]CTL = 1, $V_{DDIO} < 2.7\text{ V}$	–	–	$0.3 \times V_{DDIO}$	V
$V_{IL}$	Input voltage low threshold	LVTTL Input, PRT[*]CTL = 1, $V_{DDIO} \geq 2.7\text{ V}$	–	–	0.8	V
$V_{OH}$	Output voltage high	$I_{OH} = 4\text{ mA}$ at $3.3\text{ V}_{DDIO}$	$V_{DDIO} - 0.6$	–	–	V
		$I_{OH} = 1\text{ mA}$ at $1.8\text{ V}_{DDIO}$	$V_{DDIO} - 0.5$	–	–	V
$V_{OL}$	Output voltage low	$I_{OL} = 8\text{ mA}$ at $3.3\text{ V}_{DDIO}$	–	–	0.6	V
		$I_{OL} = 4\text{ mA}$ at $1.8\text{ V}_{DDIO}$	–	–	0.6	V
Rpullup	Pull-up resistor		3.5	5.6	8.5	k $\Omega$
Rpulldown	Pull-down resistor		3.5	5.6	8.5	k $\Omega$
$I_{IL}$	Input leakage current (absolute value) <sup>[29]</sup>	25 °C, $V_{DDIO} = 3.0\text{ V}$	–	–	2	nA
$C_{IN}$	Input capacitance <sup>[29]</sup>		–	–	7	pF
$V_H$	Input voltage hysteresis (Schmitt-Trigger) <sup>[29]</sup>		–	40	–	mV
Idiode	Current through protection diode to $V_{DDIO}$ and $V_{SSIO}$		–	–	100	$\mu\text{A}$
Rglobal	Resistance pin to analog global bus	25 °C, $V_{DDIO} = 3.0\text{ V}$	–	320	–	$\Omega$
Rmux	Resistance pin to analog mux bus	25 °C, $V_{DDIO} = 3.0\text{ V}$	–	220	–	$\Omega$

**Figure 11-13. GPIO Output High Voltage and Current**



**Figure 11-14. GPIO Output Low Voltage and Current**



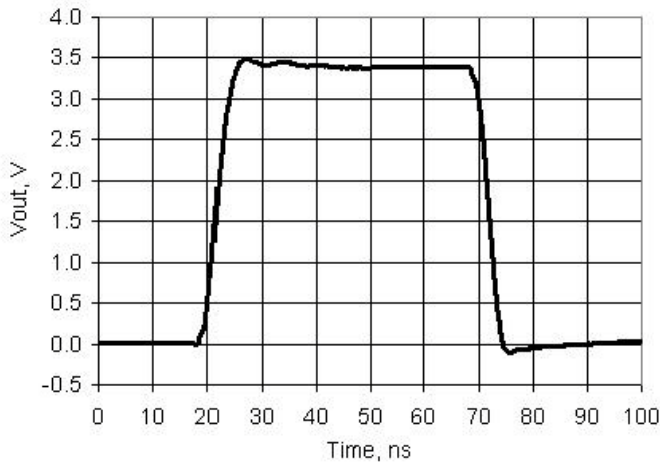
**Note**

28. Based on device characterization (Not production tested).

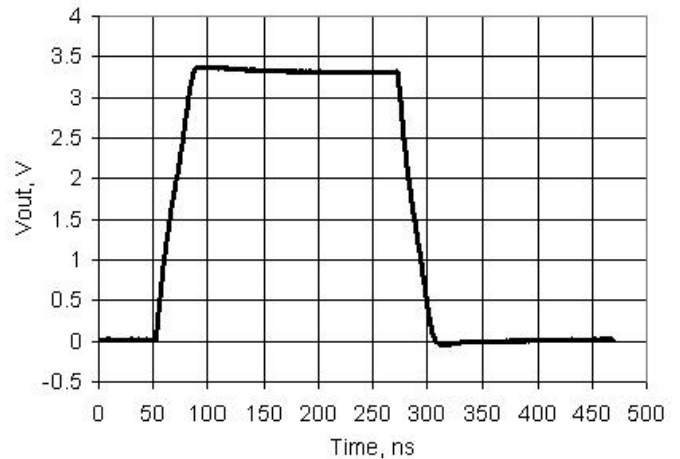
**Table 11-10. GPIO AC Specifications**

Parameter	Description	Conditions	Min	Typ	Max	Units	
TriseF	Rise time in Fast Strong Mode <sup>[29]</sup>	3.3 V V <sub>DDIO</sub> Cload = 25 pF	–	–	12	ns	
TfallF	Fall time in Fast Strong Mode <sup>[29]</sup>	3.3 V V <sub>DDIO</sub> Cload = 25 pF	–	–	12	ns	
TriseS	Rise time in Slow Strong Mode <sup>[29]</sup>	3.3 V V <sub>DDIO</sub> Cload = 25 pF	–	–	60	ns	
TfallS	Fall time in Slow Strong Mode <sup>[29]</sup>	3.3 V V <sub>DDIO</sub> Cload = 25 pF	–	–	60	ns	
Fgpiout	GPIO output operating frequency						
	2.7 V ≤ V <sub>DDIO</sub> ≤ 5.5 V, fast strong drive mode		90/10% V <sub>DDIO</sub> into 25 pF	–	–	33	MHz
	1.71 V ≤ V <sub>DDIO</sub> < 2.7 V, fast strong drive mode		90/10% V <sub>DDIO</sub> into 25 pF	–	–	20	MHz
	3.3 V ≤ V <sub>DDIO</sub> ≤ 5.5 V, slow strong drive mode		90/10% V <sub>DDIO</sub> into 25 pF	–	–	7	MHz
	1.71 V ≤ V <sub>DDIO</sub> < 3.3 V, slow strong drive mode		90/10% V <sub>DDIO</sub> into 25 pF	–	–	3.5	MHz
Fgpiin	GPIO input operating frequency						
	1.71 V ≤ V <sub>DDIO</sub> ≤ 5.5 V		90/10% V <sub>DDIO</sub>	–	–	50	MHz

**Figure 11-15. GPIO Output Rise and Fall Times, Fast Strong Mode, V<sub>DDIO</sub> = 3.3 V, 25 pF Load**



**Figure 11-16. GPIO Output Rise and Fall Times, Slow Strong Mode, V<sub>DDIO</sub> = 3.3 V, 25 pF Load**



**Note**

29. Based on device characterization (Not production tested).

## 11.1.2 SIO

**Table 11-11. SIO DC Specifications**

Parameter	Description	Conditions	Min	Typ	Max	Units
V <sub>inmax</sub>	Maximum input voltage	All allowed values of V <sub>ddio</sub> and V <sub>ddd</sub> , see <i>Section 11.2.1</i>	–	–	5.5	V
V <sub>inref</sub>	Input voltage reference (Differential input mode)		0.5	–	0.52 × V <sub>DDIO</sub>	V
V <sub>outref</sub>	Output voltage reference (Regulated output mode)					
		V <sub>DDIO</sub> > 3.7	1	–	V <sub>DDIO</sub> – 1	V
		V <sub>DDIO</sub> < 3.7	1	–	V <sub>DDIO</sub> – 0.5	V
V <sub>IH</sub>	Input voltage high threshold					
	GPIO mode	CMOS input	0.7 × V <sub>DDIO</sub>	–	–	V
	Differential input mode <sup>[30]</sup>	Hysteresis disabled	SIO_ref + 0.2	–	–	V
V <sub>IL</sub>	Input voltage low threshold					
	GPIO mode	CMOS input	–	–	0.3 × V <sub>DDIO</sub>	V
	Differential input mode <sup>[30]</sup>	Hysteresis disabled	–	–	SIO_ref – 0.2	V
V <sub>OH</sub>	Output voltage high					
	Unregulated mode	I <sub>OH</sub> = 4 mA, V <sub>DDIO</sub> = 3.3 V	V <sub>DDIO</sub> – 0.4	–	–	V
	Regulated mode <sup>[30]</sup>	I <sub>OH</sub> = 1 mA	SIO_ref – 0.65	–	SIO_ref + 0.2	V
	Regulated mode <sup>[30]</sup>	I <sub>OH</sub> = 0.1 mA	SIO_ref – 0.3	–	SIO_ref + 0.2	V
V <sub>OL</sub>	Output voltage low					
		V <sub>DDIO</sub> = 3.30 V, I <sub>OL</sub> = 25 mA	–	–	0.8	V
		V <sub>DDIO</sub> = 1.80 V, I <sub>OL</sub> = 4 mA	–	–	0.4	V
R <sub>pullup</sub>	Pull-up resistor		3.5	5.6	8.5	kΩ
R <sub>pulldown</sub>	Pull-down resistor		3.5	5.6	8.5	kΩ
I <sub>IL</sub>	Input leakage current (absolute value) <sup>[31]</sup>					
	V <sub>IH</sub> ≤ V <sub>ddio</sub>	25 °C, V <sub>ddio</sub> = 3.0 V, V <sub>IH</sub> = 3.0 V	–	–	14	nA
	V <sub>IH</sub> > V <sub>ddio</sub>	25 °C, V <sub>ddio</sub> = 0 V, V <sub>IH</sub> = 3.0 V	–	–	10	μA
C <sub>IN</sub>	Input Capacitance <sup>[31]</sup>		–	–	7	pF
V <sub>H</sub>	Input voltage hysteresis (Schmitt-Trigger) <sup>[31]</sup>					
		Single ended mode (GPIO mode)	–	40	–	mV
		Differential mode	–	35	–	mV
I <sub>diode</sub>	Current through protection diode to V <sub>SSIO</sub>		–	–	100	μA

**Notes**

 30. See [Figure 6-9](#) on page 36 and [Figure 6-12](#) on page 39 for more information on SIO reference

31. Based on device characterization (Not production tested).

Figure 11-17. SIO Output High Voltage and Current, Unregulated Mode

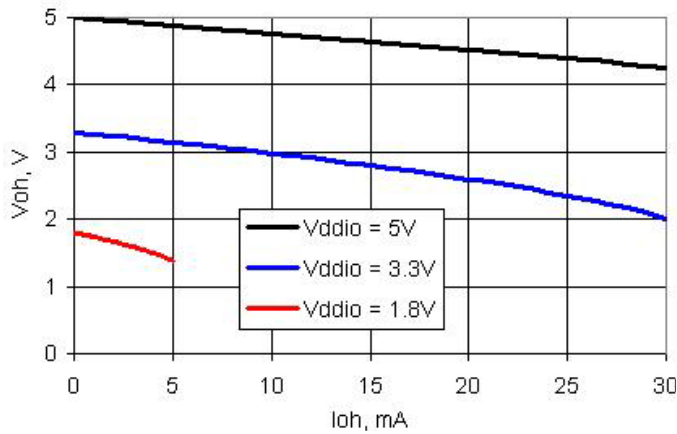


Figure 11-18. SIO Output Low Voltage and Current, Unregulated Mode

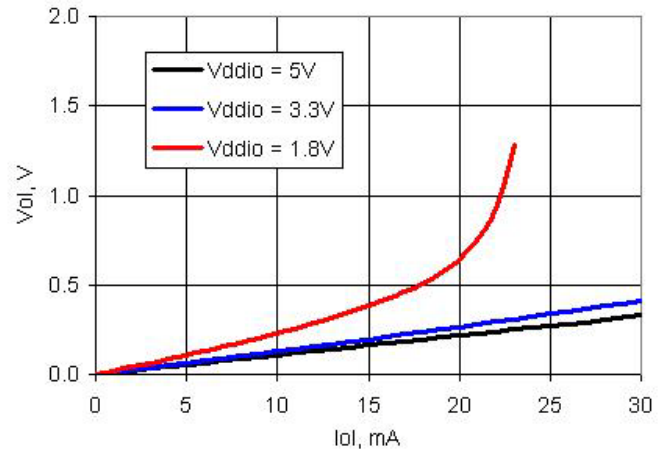


Figure 11-19. SIO Output High Voltage and Current, Regulated Mode

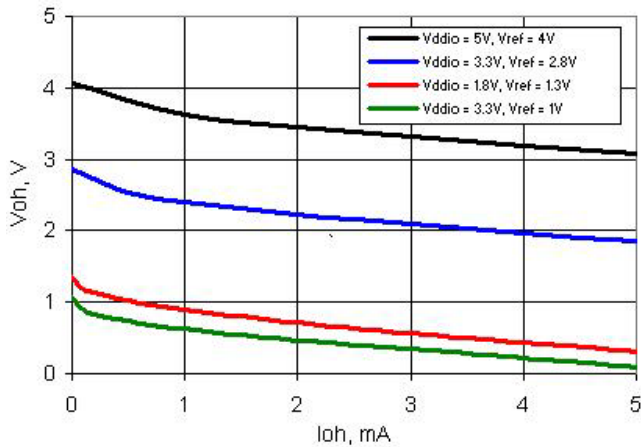


Table 11-12. SIO AC Specifications

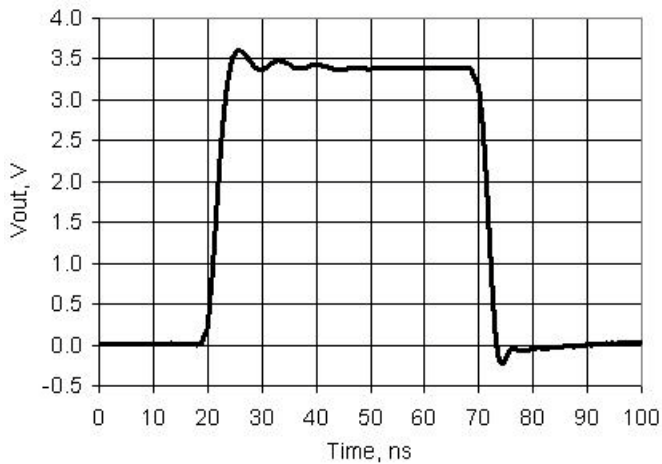
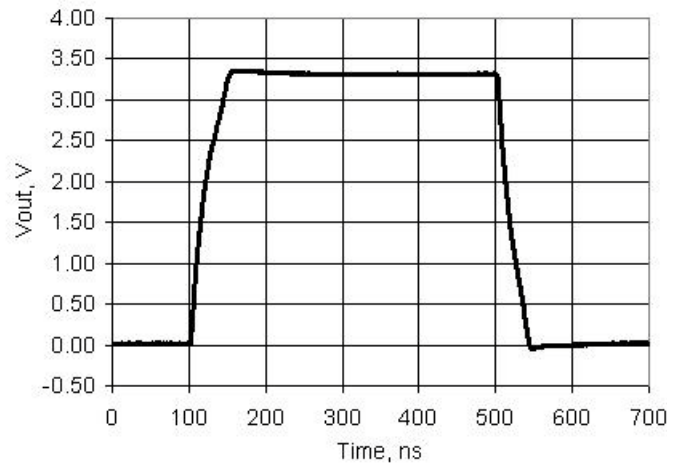
Parameter	Description	Conditions	Min	Typ	Max	Units
TriseF	Rise time in Fast Strong Mode (90/10%) <sup>[32]</sup>	Load = 25 pF, V <sub>DDIO</sub> = 3.3 V	–	–	12	ns
TfallF	Fall time in Fast Strong Mode (90/10%) <sup>[32]</sup>	Load = 25 pF, V <sub>DDIO</sub> = 3.3 V	–	–	12	ns
TriseS	Rise time in Slow Strong Mode (90/10%) <sup>[32]</sup>	Load = 25 pF, V <sub>DDIO</sub> = 3.0 V	–	–	75	ns
TfallS	Fall time in Slow Strong Mode (90/10%) <sup>[32]</sup>	Load = 25 pF, V <sub>DDIO</sub> = 3.0 V	–	–	60	ns

**Note**

32. Based on device characterization (Not production tested).

**Table 11-12. SIO AC Specifications (continued)**

Parameter	Description	Conditions	Min	Typ	Max	Units
Fsiout	SIO output operating frequency					
	2.7 V < V <sub>DDIO</sub> < 5.5 V, Unregulated output (GPIO) mode, fast strong drive mode	90/10% V <sub>DDIO</sub> into 25 pF	–	–	33	MHz
	1.71 V < V <sub>DDIO</sub> < 2.7 V, Unregulated output (GPIO) mode, fast strong drive mode	90/10% V <sub>DDIO</sub> into 25 pF	–	–	16	MHz
	3.3 V < V <sub>DDIO</sub> < 5.5 V, Unregulated output (GPIO) mode, slow strong drive mode	90/10% V <sub>DDIO</sub> into 25 pF	–	–	5	MHz
	1.71 V < V <sub>DDIO</sub> < 3.3 V, Unregulated output (GPIO) mode, slow strong drive mode	90/10% V <sub>DDIO</sub> into 25 pF	–	–	4	MHz
	2.7 V < V <sub>DDIO</sub> < 5.5 V, Regulated output mode, fast strong drive mode	Output continuously switching into 25 pF	–	–	20	MHz
	1.71 V < V <sub>DDIO</sub> < 2.7 V, Regulated output mode, fast strong drive mode	Output continuously switching into 25 pF	–	–	10	MHz
	1.71 V < V <sub>DDIO</sub> < 5.5 V, Regulated output mode, slow strong drive mode	Output continuously switching into 25 pF	–	–	2.5	MHz
Fsiain	SIO input operating frequency					
	1.71 V ≤ V <sub>DDIO</sub> ≤ 5.5 V	90/10% V <sub>DDIO</sub>	–	–	50	MHz

**Figure 11-20. SIO Output Rise and Fall Times, Fast Strong Mode, V<sub>DDIO</sub> = 3.3 V, 25 pF Load**

**Figure 11-21. SIO Output Rise and Fall Times, Slow Strong Mode, V<sub>DDIO</sub> = 3.3 V, 25 pF Load**


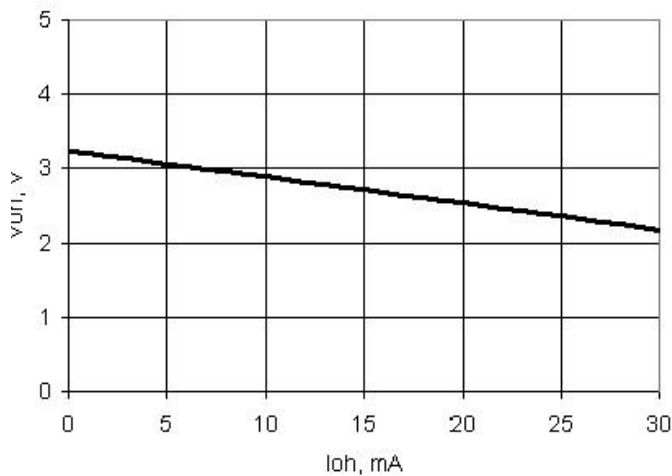
11.1.3 USBIO

For operation in GPIO mode, the standard range for  $V_{DD}$  applies, see [Device Level Specifications](#) on page 65.

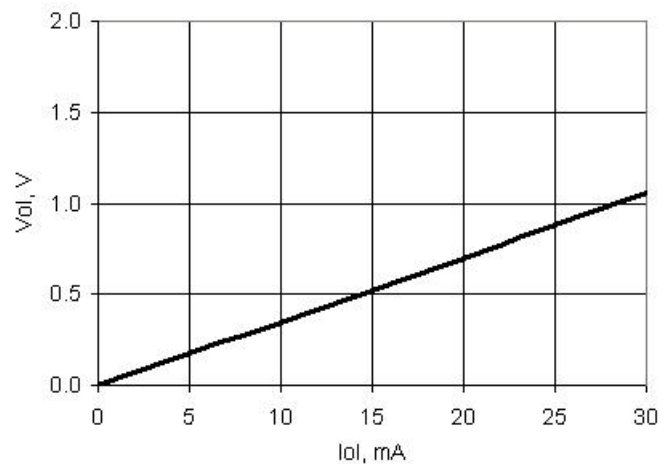
**Table 11-13. USBIO DC Specifications**

Parameter	Description	Conditions	Min	Typ	Max	Units
Rusbi	USB D+ pull-up resistance	With idle bus	0.900	–	1.575	k $\Omega$
Rusba	USB D+ pull-up resistance	While receiving traffic	1.425	–	3.090	k $\Omega$
Vohusb	Static output high	15 k $\Omega$ $\pm$ 5% to Vss, internal pull-up enabled	2.8	–	3.6	V
Volusb	Static output low	15 k $\Omega$ $\pm$ 5% to Vss, internal pull-up enabled	–	–	0.3	V
Vohgpio	Output voltage high, GPIO mode	$I_{OH} = 4$ mA, $V_{DD} \geq 3$ V	2.4	–	–	V
Volgpio	Output voltage low, GPIO mode	$I_{OL} = 4$ mA, $V_{DD} \geq 3$ V	–	–	0.3	V
Vdi	Differential input sensitivity	$ (D+) - (D-) $	–	–	0.2	V
Vcm	Differential input common mode range	–	0.8	–	2.5	V
Vse	Single ended receiver threshold	–	0.8	–	2	V
Rps2	PS/2 pull-up resistance	In PS/2 mode, with PS/2 pull-up enabled	3	–	7	k $\Omega$
Rext	External USB series resistor	In series with each USB pin	21.78 (–1%)	22	22.22 (+1%)	$\Omega$
Zo	USB driver output impedance	Including Rext	28	–	44	$\Omega$
C <sub>IN</sub>	USB transceiver input capacitance	–	–	–	20	pF
I <sub>IL</sub>	Input leakage current (absolute value)	25 °C, $V_{DD} = 3.0$ V	–	–	2	nA

**Figure 11-22. USBIO Output High Voltage and Current, GPIO Mode**



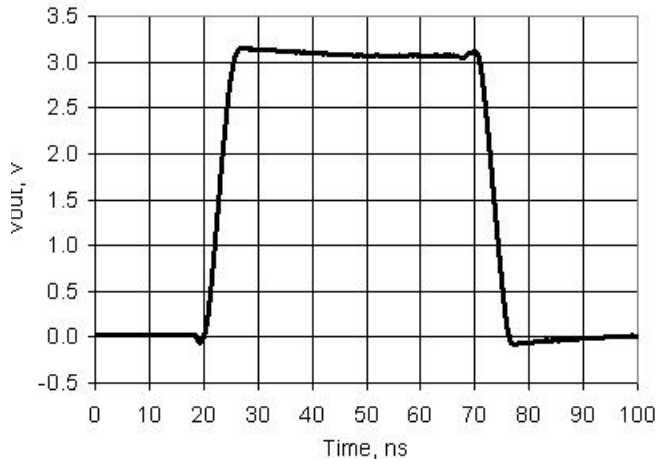
**Figure 11-23. USBIO Output Low Voltage and Current, GPIO Mode**



**Table 11-14. USBIO AC Specifications**

Parameter	Description	Conditions	Min	Typ	Max	Units
Tdrate	Full-speed data rate average bit rate		12 – 0.25%	12	12 + 0.25%	MHz
Tjr1	Receiver data jitter tolerance to next transition		–8	–	8	ns
Tjr2	Receiver data jitter tolerance to pair transition		–5	–	5	ns
Tdj1	Driver differential jitter to next transition		–3.5	–	3.5	ns
Tdj2	Driver differential jitter to pair transition		–4	–	4	ns
Tfdeop	Source jitter for differential transition to SE0 transition		–2	–	5	ns
Tfeopt	Source SE0 interval of EOP		160	–	175	ns
Tfeopr	Receiver SE0 interval of EOP		82	–	–	ns
Tfst	Width of SE0 interval during differential transition		–	–	14	ns
Fgpio_out	GPIO mode output operating frequency	$3\text{ V} \leq V_{\text{DDD}} \leq 5.5\text{ V}$	–	–	20	MHz
		$V_{\text{DDD}} = 1.71\text{ V}$	–	–	6	MHz
Tr_gpio	Rise time, GPIO mode, 10%/90% $V_{\text{DDD}}$	$V_{\text{DDD}} > 3\text{ V}$ , 25 pF load	–	–	12	ns
		$V_{\text{DDD}} = 1.71\text{ V}$ , 25 pF load	–	–	40	ns
Tf_gpio	Fall time, GPIO mode, 90%/10% $V_{\text{DDD}}$	$V_{\text{DDD}} > 3\text{ V}$ , 25 pF load	–	–	12	ns
		$V_{\text{DDD}} = 1.71\text{ V}$ , 25 pF load	–	–	40	ns

**Figure 11-24. USBIO Output Rise and Fall Times, GPIO Mode,  $V_{\text{DDD}} = 3.3\text{ V}$ , 25 pF Load**



**Table 11-15. USB Driver AC Specifications**

Parameter	Description	Conditions	Min	Typ	Max	Units
Tr	Transition rise time		–	–	20	ns
Tf	Transition fall time		–	–	20	ns
TR	Rise/fall time matching	$V_{\text{USB}_5}$ , $V_{\text{USB}_3.3}$ , see <a href="#">USB DC Specifications</a> on page 95	90%	–	111%	
Vcrs	Output signal crossover voltage		1.3	–	2	V

## 11.1.4 XRES

**Table 11-16. XRES DC Specifications**

Parameter	Description	Conditions	Min	Typ	Max	Units
V <sub>IH</sub>	Input voltage high threshold		$0.7 \times V_{DDIO}$	–	–	V
V <sub>IL</sub>	Input voltage low threshold		–	–	$0.3 \times V_{DDIO}$	V
R <sub>pullup</sub>	Pull-up resistor		3.5	5.6	8.5	kΩ
C <sub>IN</sub>	Input capacitance <sup>[33]</sup>		–	3	–	pF
V <sub>H</sub>	Input voltage hysteresis (Schmitt-Trigger) <sup>[33]</sup>		–	100	–	mV
I <sub>diode</sub>	Current through protection diode to V <sub>DDIO</sub> and V <sub>SSIO</sub>		–	–	100	μA

**Table 11-17. XRES AC Specifications**

Parameter	Description	Conditions	Min	Typ	Max	Units
T <sub>RESET</sub>	Reset pulse width		1	–	–	μs



## 11.2 Analog Peripherals

Specifications are valid for  $-40\text{ }^{\circ}\text{C} \leq T_A \leq 85\text{ }^{\circ}\text{C}$  and  $T_J \leq 100\text{ }^{\circ}\text{C}$ , except where noted. Specifications are valid for 1.71 V to 5.5 V, except where noted.

### 11.2.1 Delta-sigma ADC

Unless otherwise specified, operating conditions are:

- Operation in continuous sample mode
- fclk = 6.144 MHz
- Reference = 1.024 V internal reference bypassed on P3.2 or P0.3
- Unless otherwise specified, all charts and graphs show typical values

**Table 11-18. 12-bit Delta-sigma ADC DC Specifications**

Parameter	Description	Conditions	Min	Typ	Max	Units
	Resolution		8	–	12	bits
	Number of channels, single ended		–	–	No. of GPIO	–
	Number of channels, differential	Differential pair is formed using a pair of GPIOs.	–	–	No. of GPIO/2	–
	Monotonic	Yes	–	–	–	–
Ge	Gain error	Buffered, buffer gain = 1, Range = $\pm 1.024\text{ V}$ , $25\text{ }^{\circ}\text{C}$	–	–	$\pm 0.2$	%
Gd	Gain drift	Buffered, buffer gain = 1, Range = $\pm 1.024\text{ V}$	–	–	50	ppm/ $^{\circ}\text{C}$
Vos	Input offset voltage	Buffered, 16-bit mode, $V_{DDA} = 2.7\text{ V}$ , $25\text{ }^{\circ}\text{C}$	–	–	$\pm 0.1$	mV
TCVos	Temperature coefficient, input offset voltage	Buffer gain = 1, 16-bit, Range = $\pm 1.024\text{ V}$	–	–	55	$\mu\text{V}/^{\circ}\text{C}$
	Input voltage range, single ended <sup>[34]</sup>		$V_{SSA}$	–	$V_{DDA}$	V
	Input voltage range, differential unbuffered <sup>[34]</sup>		$V_{SSA}$	–	$V_{DDA}$	V
	Input voltage range, differential, buffered <sup>[34]</sup>		$V_{SSA}$	–	$V_{DDA} - 1$	V
INL12	Integral non linearity <sup>[34]</sup>	Range = $\pm 1.024\text{ V}$ , unbuffered	–	–	$\pm 1$	LSB
DNL12	Differential non linearity <sup>[34]</sup>	Range = $\pm 1.024\text{ V}$ , unbuffered	–	–	$\pm 1$	LSB
INL8	Integral non linearity <sup>[34]</sup>	Range = $\pm 1.024\text{ V}$ , unbuffered	–	–	$\pm 1$	LSB
DNL8	Differential non linearity <sup>[34]</sup>	Range = $\pm 1.024\text{ V}$ , unbuffered	–	–	$\pm 1$	LSB
Rin_Buff	ADC input resistance	Input buffer used	10	–	–	M $\Omega$
Rin_ADC12	ADC input resistance	Input buffer bypassed, 12 bit, Range = $\pm 1.024\text{ V}$	–	148 <sup>[35]</sup>	–	k $\Omega$
Vextref	ADC external reference input voltage, see also internal reference in <a href="#">Voltage Reference</a> on page 83	Pins P0[3], P3[2]	0.9	–	1.3	V
<b>Current Consumption</b>						
I <sub>DD_12</sub>	Current consumption, 12 bit <sup>[34]</sup>	192 ksps, unbuffered	–	–	1.4	mA
I <sub>BUFF</sub>	Buffer current consumption <sup>[34]</sup>		–	–	2.5	mA

#### Notes

34. Based on device characterization (Not production tested).

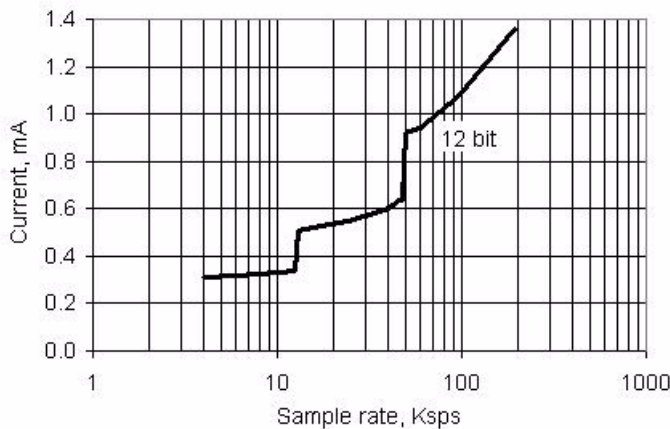
35. By using switched capacitors at the ADC input an effective input resistance is created. Holding the gain and number of bits constant, the resistance is proportional to the inverse of the clock frequency. This value is calculated, not measured. For more information see the Technical Reference Manual.

**Table 11-19. Delta-sigma ADC AC Specifications**

Parameter	Description	Conditions	Min	Typ	Max	Units
	Startup time		–	–	4	Samples
THD	Total harmonic distortion <sup>[36]</sup>	Buffer gain = 1, 16 bit, Range = ±1.024 V	–	–	0.0032	%
<b>12-Bit Resolution Mode</b>						
SR12	Sample rate, continuous, high power <sup>[36]</sup>	Range = ±1.024 V, unbuffered	4	–	192	ksps
BW12	Input bandwidth at max sample rate <sup>[36]</sup>	Range = ±1.024 V, unbuffered	–	44	–	kHz
SINAD12int	Signal to noise ratio, 12-bit, internal reference <sup>[36]</sup>	Range = ±1.024 V, unbuffered	66	–	–	dB
<b>8-Bit Resolution Mode</b>						
SR8	Sample rate, continuous, high power <sup>[36]</sup>	Range = ±1.024 V, unbuffered	8	–	384	ksps
BW8	Input bandwidth at max sample rate <sup>[36]</sup>	Range = ±1.024 V, unbuffered	–	88	–	kHz
SINAD8int	Signal to noise ratio, 8-bit, internal reference <sup>[36]</sup>	Range = ±1.024 V, unbuffered	43	–	–	dB

**Table 11-20. Delta-sigma ADC Sample Rates, Range = ±1.024 V**

Resolution, Bits	Continuous		Multi-Sample	
	Min	Max	Min	Max
8	8000	384000	1911	91701
9	6400	307200	1543	74024
10	5566	267130	1348	64673
11	4741	227555	1154	55351
12	4000	192000	978	46900

**Figure 11-25. Delta-sigma ADC IDD vs sps, Range = ±1.024 V, Continuous Sample Mode, Input Buffer Bypassed**

**Note**

36. Based on device characterization (Not production tested).

11.2.2 Voltage Reference

**Table 11-21. Voltage Reference Specifications**

See also ADC external reference specifications in *Section 11.2.1*.

Parameter	Description	Conditions	Min	Typ	Max	Units
V <sub>REF</sub>	Precision reference voltage	Initial trim	1.014 (-1%)	1.024	1.034 (+1%)	V

11.2.3 Analog Globals

**Table 11-22. Analog Globals Specifications**

Parameter	Description	Conditions	Min	Typ	Max	Units
R <sub>ppag</sub>	Resistance pin-to-pin through analog global <sup>[37]</sup>	V <sub>DDA</sub> = 3.0 V	–	939	1461	Ω
R <sub>ppmuxbus</sub>	Resistance pin-to-pin through analog mux bus <sup>[37]</sup>	V <sub>DDA</sub> = 3.0 V	–	721	1135	Ω

11.2.4 Comparator

**Table 11-23. Comparator DC Specifications**

Parameter	Description	Conditions	Min	Typ	Max	Units
V <sub>OS</sub>	Input offset voltage in fast mode	Factory trim, V <sub>DDA</sub> > 2.7 V, V <sub>in</sub> ≥ 0.5 V	–		10	mV
	Input offset voltage in slow mode	Factory trim, V <sub>in</sub> ≥ 0.5 V	–		9	mV
V <sub>OS</sub>	Input offset voltage in fast mode <sup>[38]</sup>	Custom trim	–	–	4	mV
	Input offset voltage in slow mode <sup>[38]</sup>	Custom trim	–	–	4	mV
V <sub>OS</sub>	Input offset voltage in ultra low-power mode		–	±12	–	mV
V <sub>HYST</sub>	Hysteresis	Hysteresis enable mode	–	10	32	mV
V <sub>ICM</sub>	Input common mode voltage	High current / fast mode	V <sub>SSA</sub>	–	V <sub>DDA</sub> – 0.1	V
		Low current / slow mode	V <sub>SSA</sub>	–	V <sub>DDA</sub>	V
		Ultra low power mode	V <sub>SSA</sub>	–	V <sub>DDA</sub> – 0.9	
CMRR	Common mode rejection ratio		–	50	–	dB
I <sub>CMP</sub>	High current mode/fast mode <sup>[39]</sup>		–	–	400	μA
	Low current mode/slow mode <sup>[39]</sup>		–	–	100	μA
	Ultra low-power mode <sup>[39]</sup>		–	6	–	μA

**Table 11-24. Comparator AC Specifications**

Parameter	Description	Conditions	Min	Typ	Max	Units
T <sub>resp</sub>	Response time, high current mode <sup>[39]</sup>	50 mV overdrive, measured pin-to-pin	–	75	110	ns
	Response time, low current mode <sup>[39]</sup>	50 mV overdrive, measured pin-to-pin	–	155	200	ns
	Response time, ultra low-power mode <sup>[39]</sup>	50 mV overdrive, measured pin-to-pin	–	55	–	μs

**Notes**

37. The resistance of the analog global and analog mux bus is high if V<sub>DDA</sub> ≤ 2.7 V, and the chip is in either sleep or hibernate mode. Use of analog global and analog mux bus under these conditions is not recommended

38. The recommended procedure for using a custom trim value for the on-chip comparators can be found in the TRM.

39. Based on device characterization (Not production tested).

### 11.2.5 Current Digital-to-analog Converter (IDAC)

See the IDAC component datasheet in PSoC Creator for full electrical specifications and APIs.

Unless otherwise specified, all charts and graphs show typical values.

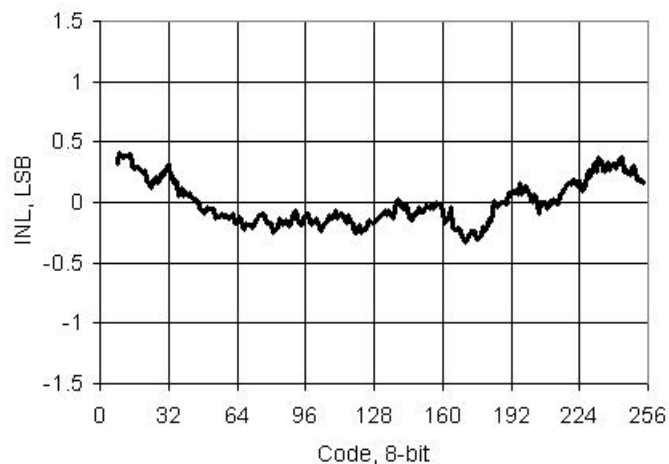
**Table 11-25. IDAC DC Specifications**

Parameter	Description	Conditions	Min	Typ	Max	Units
	Resolution		–	–	8	bits
I <sub>OUT</sub>	Output current at code = 255	Range = 2.048 mA, code = 255, V <sub>DDA</sub> ≥ 2.7 V, R <sub>load</sub> = 600 Ω	–	2.048	–	mA
		Range = 2.048 mA, High mode, code = 255, V <sub>DDA</sub> ≤ 2.7 V, R <sub>load</sub> = 300 Ω	–	2.048	–	mA
		Range = 255 μA, code = 255, R <sub>load</sub> = 600 Ω	–	255	–	μA
		Range = 31.875 μA, code = 255, R <sub>load</sub> = 600 Ω	–	31.875	–	μA
	Monotonicity		–	–	Yes	
E <sub>zs</sub>	Zero scale error		–	0	±1	LSB
E <sub>g</sub>	Gain error	Range = 2.048 mA, 25 °C	–	–	±2.5	%
		Range = 255 μA, 25 °C	–	–	±2.5	%
		Range = 31.875 μA, 25 °C	–	–	±3.5	%
TC_Eg	Temperature coefficient of gain error	Range = 2.048 mA	–	–	0.04	% / °C
		Range = 255 μA	–	–	0.04	% / °C
		Range = 31.875 μA	–	–	0.05	% / °C
INL	Integral nonlinearity	Sink mode, range = 255 μA, Codes 8 – 255, R <sub>load</sub> = 2.4 kΩ, C <sub>load</sub> = 15 pF	–	±0.9	±1	LSB
		Source mode, range = 255 μA, Codes 8 – 255, R <sub>load</sub> = 2.4 kΩ, C <sub>load</sub> = 15 pF	–	±1.2	±1.5	LSB
DNL	Differential nonlinearity	Sink mode, range = 255 μA, R <sub>load</sub> = 2.4 kΩ, C <sub>load</sub> = 15 pF	–	±0.3	±1	LSB
		Source mode, range = 255 μA, R <sub>load</sub> = 2.4 kΩ, C <sub>load</sub> = 15 pF	–	±0.3	±1	LSB
V <sub>compliance</sub>	Dropout voltage, source or sink mode	Voltage headroom at max current, R <sub>load</sub> to V <sub>dda</sub> or R <sub>load</sub> to V <sub>ssa</sub> , V <sub>diff</sub> from V <sub>dda</sub>	1	–	–	V

**Table 11-25. IDAC DC Specifications (continued)**

Parameter	Description	Conditions	Min	Typ	Max	Units
I <sub>DD</sub>	Operating current, code = 0	Slow mode, source mode, range = 31.875 $\mu$ A	–	44	100	$\mu$ A
		Slow mode, source mode, range = 255 $\mu$ A,	–	33	100	$\mu$ A
		Slow mode, source mode, range = 2.04 mA	–	33	100	$\mu$ A
		Slow mode, sink mode, range = 31.875 $\mu$ A	–	36	100	$\mu$ A
		Slow mode, sink mode, range = 255 $\mu$ A	–	33	100	$\mu$ A
		Slow mode, sink mode, range = 2.04 mA	–	33	100	$\mu$ A
		Fast mode, source mode, range = 31.875 $\mu$ A	–	310	500	$\mu$ A
		Fast mode, source mode, range = 255 $\mu$ A	–	305	500	$\mu$ A
		Fast mode, source mode, range = 2.04 mA	–	305	500	$\mu$ A
		Fast mode, sink mode, range = 31.875 $\mu$ A	–	310	500	$\mu$ A
		Fast mode, sink mode, range = 255 $\mu$ A	–	300	500	$\mu$ A
		Fast mode, sink mode, range = 2.04 mA	–	300	500	$\mu$ A

**Figure 11-26. IDAC INL vs Input Code, Range = 255  $\mu$ A, Source Mode**



**Figure 11-27. IDAC INL vs Input Code, Range = 255  $\mu$ A, Sink Mode**

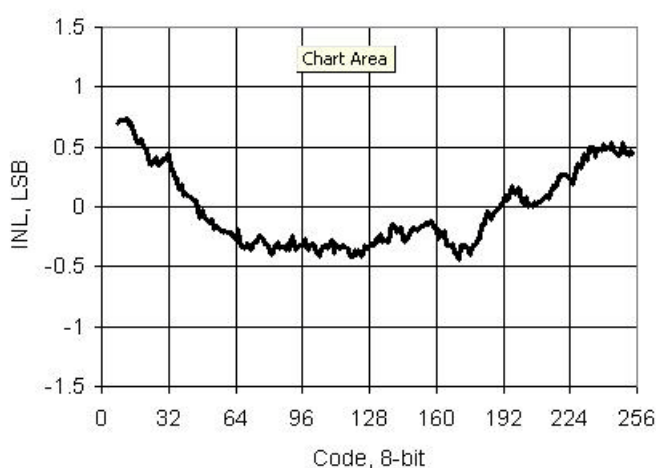


Figure 11-28. IDAC DNL vs Input Code, Range = 255  $\mu$ A, Source Mode

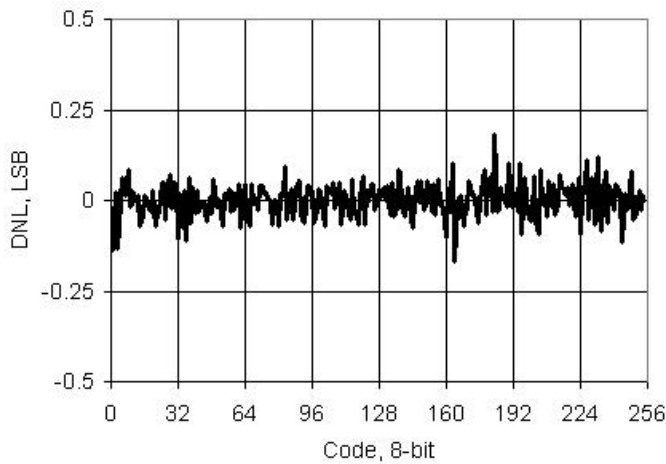


Figure 11-29. IDAC DNL vs Input Code, Range = 255  $\mu$ A, Sink Mode

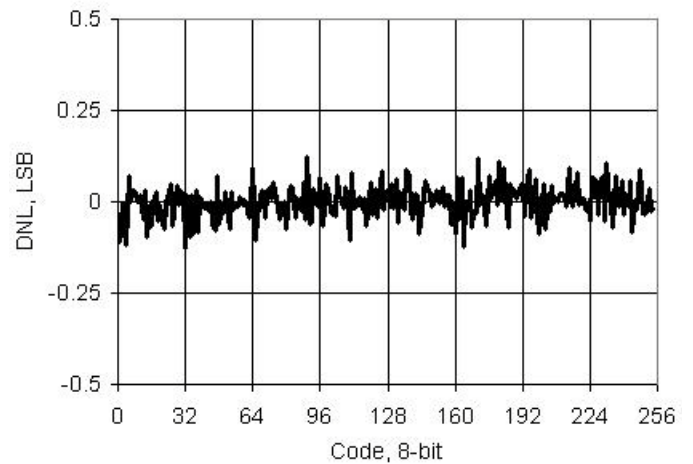


Figure 11-30. IDAC INL vs Temperature, Range = 255  $\mu$ A, Fast Mode

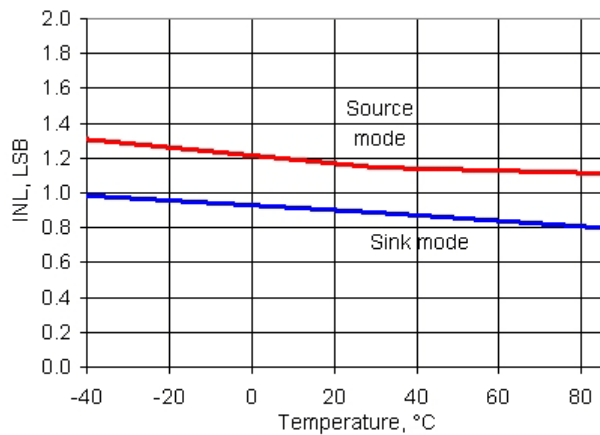
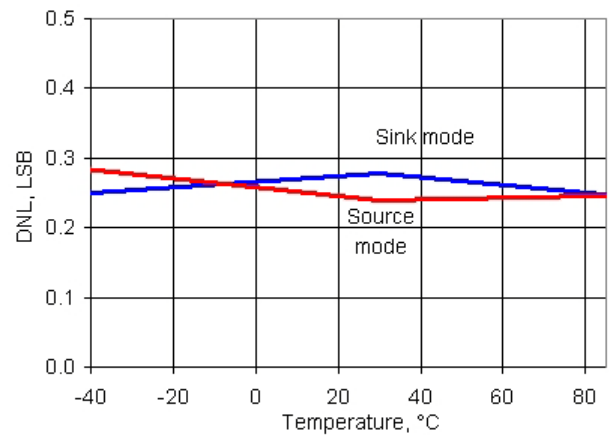
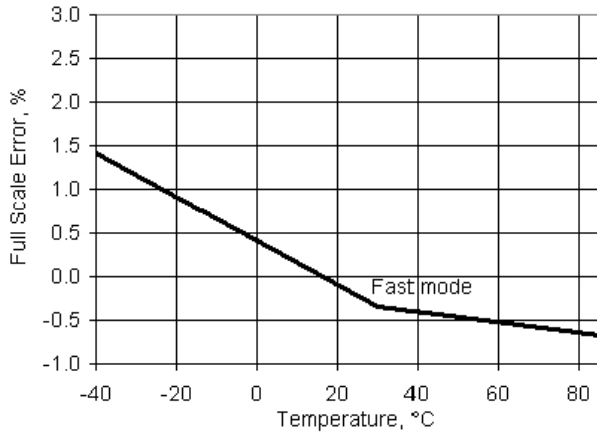


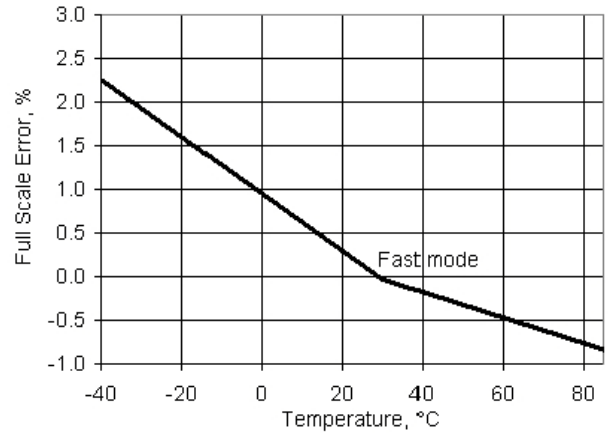
Figure 11-31. IDAC DNL vs Temperature, Range = 255  $\mu$ A, Fast Mode



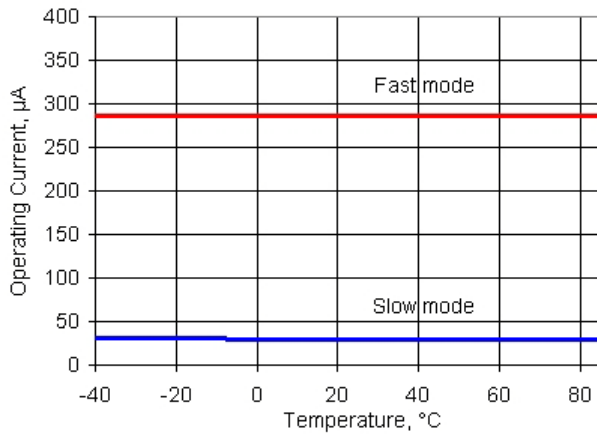
**Figure 11-32. IDAC Full Scale Error vs Temperature, Range = 255  $\mu$ A, Source Mode**



**Figure 11-33. IDAC Full Scale Error vs Temperature, Range = 255  $\mu$ A, Sink Mode**



**Figure 11-34. IDAC Operating Current vs Temperature, Range = 255  $\mu$ A, Code = 0, Source Mode**



**Figure 11-35. IDAC Operating Current vs Temperature, Range = 255  $\mu$ A, Code = 0, Sink Mode**

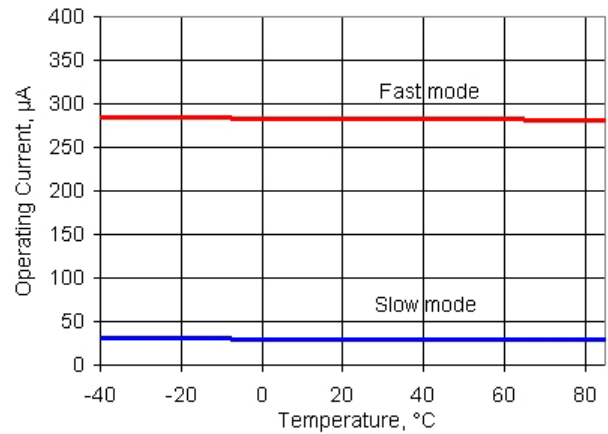


Table 11-26. IDAC AC Specifications

Parameter	Description	Conditions	Min	Typ	Max	Units
F <sub>DAC</sub>	Update rate		–	–	8	Msp/s
T <sub>SETTLE</sub>	Settling time to 0.5 LSB	Range = 31.875 $\mu$ A or 255 $\mu$ A, full scale transition, fast mode, 600 $\Omega$ 15-pF load	–	–	125	ns

Figure 11-36. IDAC Step Response, Codes 0x40 - 0xC0, 255  $\mu$ A Mode, Source Mode, Fast Mode, V<sub>DDA</sub> = 5 V

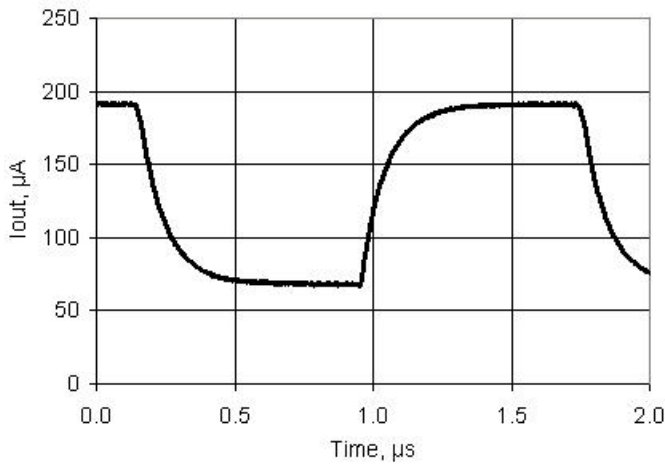


Figure 11-37. IDAC Glitch Response, Codes 0x7F - 0x80, 255  $\mu$ A Mode, Source Mode, Fast Mode, V<sub>DDA</sub> = 5 V

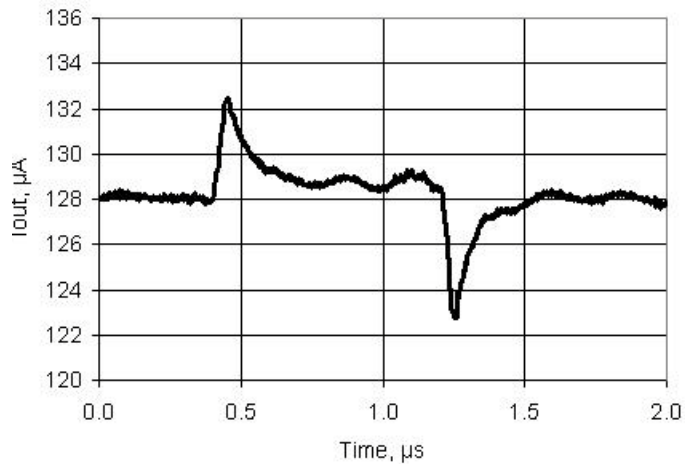
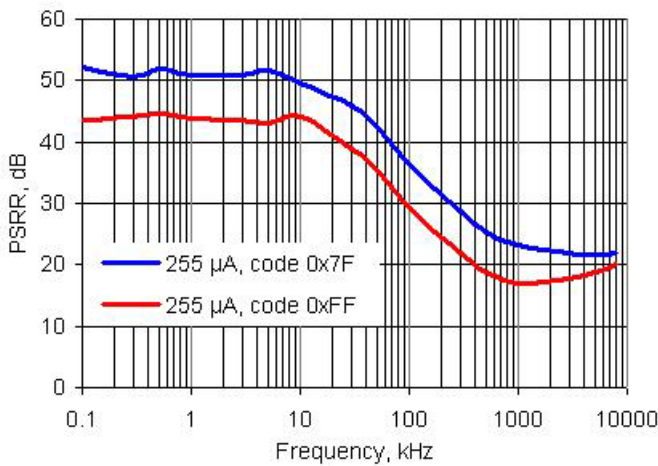


Figure 11-38. IDAC PSRR vs Frequency





11.2.6 Voltage Digital to Analog Converter (VDAC)

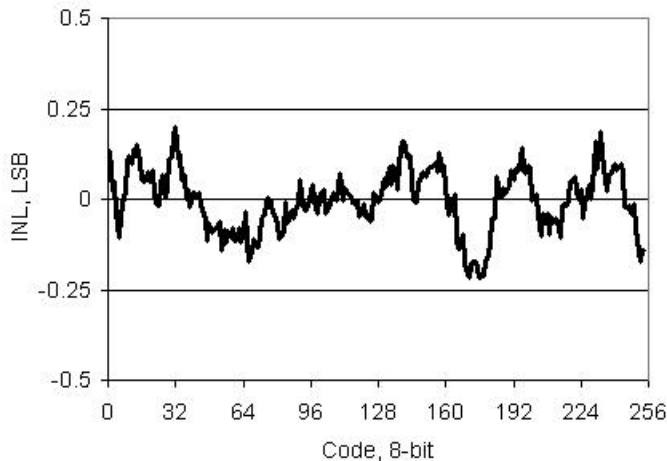
See the VDAC component datasheet in PSoC Creator for full electrical specifications and APIs.

Unless otherwise specified, all charts and graphs show typical values.

**Table 11-27. VDAC DC Specifications**

Parameter	Description	Conditions	Min	Typ	Max	Units
	Resolution		–	8	–	bits
INL1	Integral nonlinearity	1 V scale	–	±2.1	±2.5	LSB
DNL1	Differential nonlinearity	1 V scale	–	±0.3	±1	LSB
Rout	Output resistance	1 V scale	–	4	–	kΩ
		4 V scale	–	16	–	kΩ
V <sub>OUT</sub>	Output voltage range, code = 255	1 V scale	–	1	–	V
		4 V scale, V <sub>dda</sub> = 5 V	–	4	–	V
	Monotonicity		–	–	Yes	–
V <sub>OS</sub>	Zero scale error		–	0	±0.9	LSB
Eg	Gain error	1 V scale	–	–	±2.5	%
		4 V scale	–	–	±2.5	%
TC_Eg	Temperature coefficient, gain error	1 V scale	–	–	0.03	%FSR / °C
		4 V scale	–	–	0.03	%FSR / °C
I <sub>DD</sub>	Operating current	Slow mode	–	–	100	μA
		Fast mode	–	–	500	μA

**Figure 11-39. VDAC INL vs Input Code, 1 V Mode**



**Figure 11-40. VDAC DNL vs Input Code, 1 V Mode**

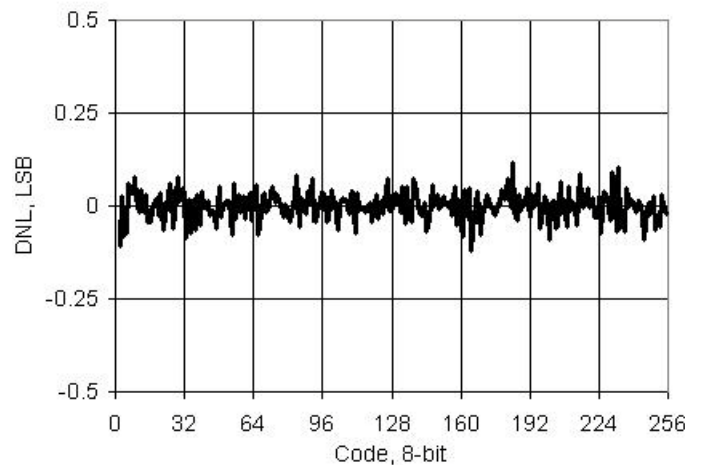


Figure 11-41. VDAC INL vs Temperature, 1 V Mode

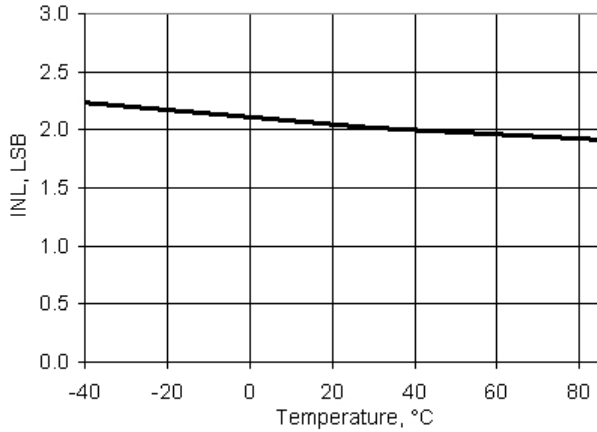


Figure 11-42. VDAC DNL vs Temperature, 1 V Mode

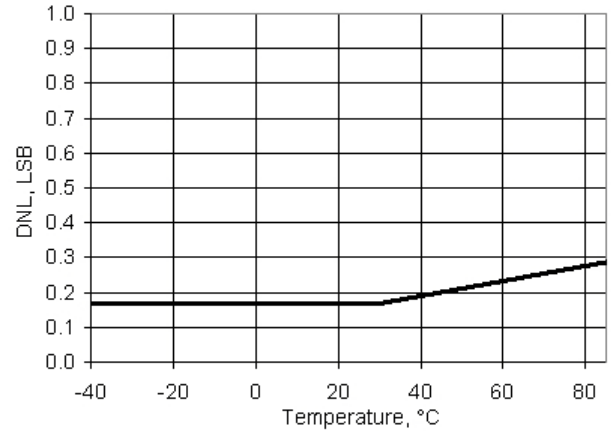


Figure 11-43. VDAC Full Scale Error vs Temperature, 1 V Mode

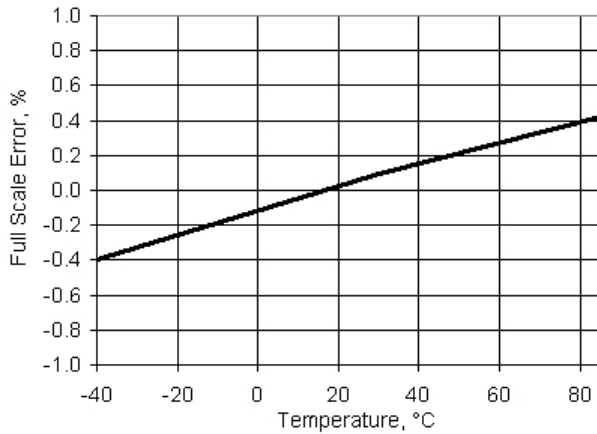


Figure 11-44. VDAC Full Scale Error vs Temperature, 4 V Mode

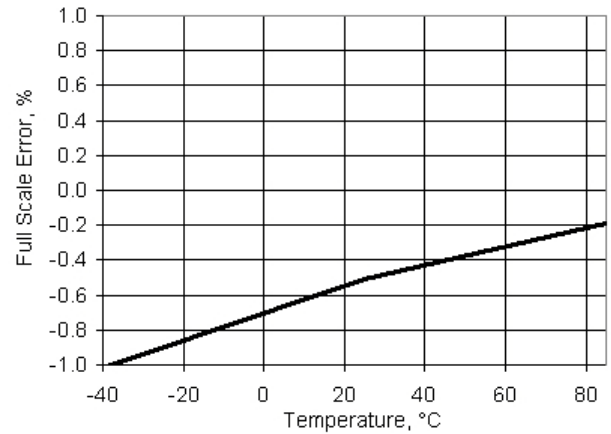


Figure 11-45. VDAC Operating Current vs Temperature, 1V Mode, Slow Mode

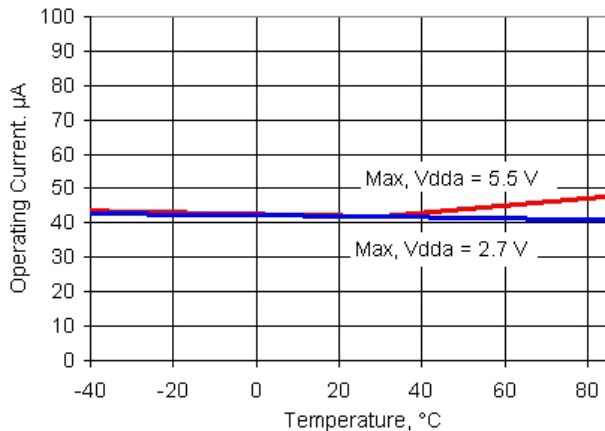
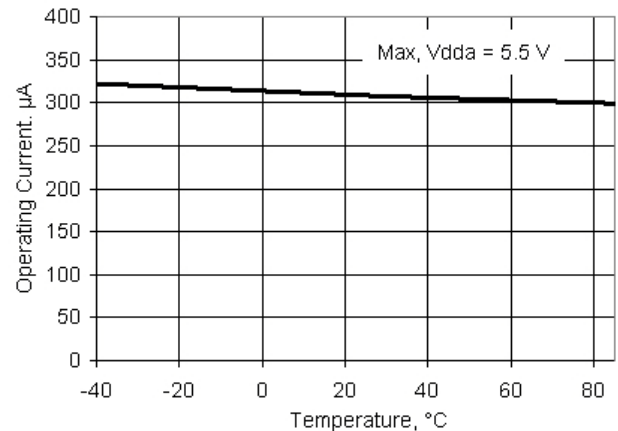


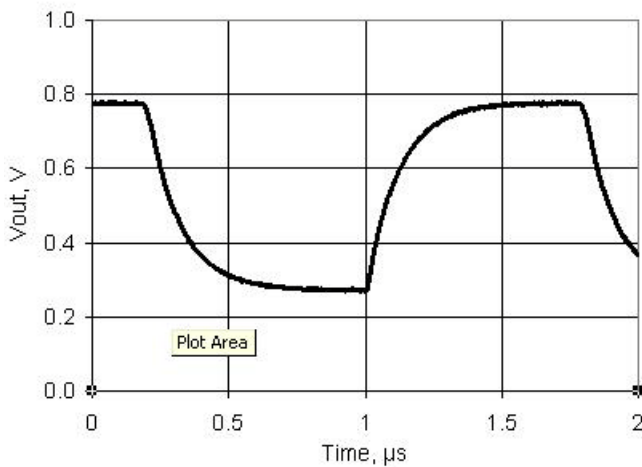
Figure 11-46. VDAC Operating Current vs Temperature, 1 V Mode, Fast Mode



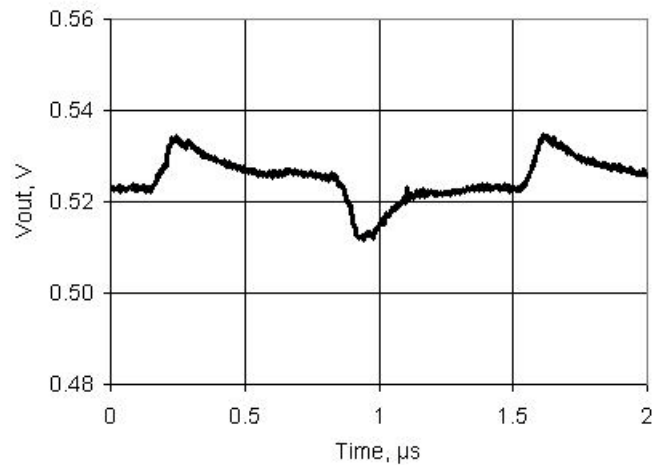
**Table 11-28. VDAC AC Specifications t**

Parameter	Description	Conditions	Min	Typ	Max	Units
F <sub>DAC</sub>	Update rate	1 V scale	–	–	1000	ksps
		4 V scale	–	–	250	ksps
T <sub>settleP</sub>	Settling time to 0.1%, step 25% to 75%	1 V scale, Cload = 15 pF	–	0.45	1	μs
		4 V scale, Cload = 15 pF	–	0.8	3.2	μs
T <sub>settleN</sub>	Settling time to 0.1%, step 75% to 25%	1 V scale, Cload = 15 pF	–	0.45	1	μs
		4 V scale, Cload = 15 pF	–	0.7	3	μs

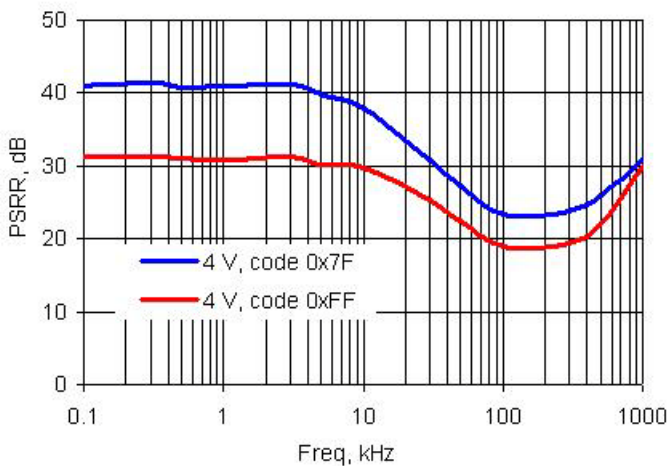
**Figure 11-47. VDAC Step Response, Codes 0x40 - 0xC0, 1 V Mode, Fast Mode, V<sub>dda</sub> = 5 V**



**Figure 11-48. VDAC Glitch Response, Codes 0x7F - 0x80, 1 V Mode, Fast Mode, V<sub>dda</sub> = 5 V**



**Figure 11-49. VDAC PSRR vs Frequency**



## 11.2.7 Temperature Sensor

**Table 11-29. Temperature Sensor Specifications**

Parameter	Description	Conditions	Min	Typ	Max	Units
	Temp sensor accuracy	Range: -40 °C to +85 °C	-	±5	-	°C

## 11.2.8 LCD Direct Drive

**Table 11-30. LCD Direct Drive DC Specifications**

Parameter	Description	Conditions	Min	Typ	Max	Units
I <sub>CC</sub>	LCD system operating current	Device sleep mode with wakeup at 400-Hz rate to refresh LCDs, bus clock = 3 Mhz, V <sub>ddio</sub> = V <sub>dda</sub> = 3 V, 4 commons, 16 segments, 1/4 duty cycle, 50 Hz frame rate, no glass connected	-	38	-	μA
I <sub>CC_SEG</sub>	Current per segment driver	Strong drive mode	-	260	-	μA
V <sub>BIAS</sub>	LCD bias range (V <sub>BIAS</sub> refers to the main output voltage(V <sub>O</sub> ) of LCD DAC)	V <sub>DDA</sub> ≥ 3 V and V <sub>DDA</sub> ≥ V <sub>BIAS</sub>	2	-	5	V
	LCD bias step size	V <sub>DDA</sub> ≥ 3 V and V <sub>DDA</sub> ≥ V <sub>BIAS</sub>	-	9.1 × V <sub>DDA</sub>	-	mV
	LCD capacitance per segment/common driver	Drivers may be combined	-	500	5000	pF
	Long term segment offset		-	-	20	mV
I <sub>OUT</sub>	Output drive current per segment driver)	V <sub>ddio</sub> = 5.5V, strong drive mode	355	-	710	μA

**Table 11-31. LCD Direct Drive AC Specifications**

Parameter	Description	Conditions	Min	Typ	Max	Units
f <sub>LCD</sub>	LCD frame rate		10	50	150	Hz

### 11.3 Digital Peripherals

Specifications are valid for  $-40\text{ }^{\circ}\text{C} \leq T_A \leq 85\text{ }^{\circ}\text{C}$  and  $T_J \leq 100\text{ }^{\circ}\text{C}$ , except where noted. Specifications are valid for 1.71 V to 5.5 V, except where noted.

#### 11.3.1 Timer

The following specifications apply to the Timer/Counter/PWM peripheral in timer mode. Timers can also be implemented in UDBs; for more information, see the Timer component datasheet in PSoC Creator.

**Table 11-32. Timer DC Specifications**

Parameter	Description	Conditions	Min	Typ	Max	Units
	Block current consumption	16-bit timer, at listed input clock frequency	–	–	–	$\mu\text{A}$
	3 MHz		–	15	–	$\mu\text{A}$
	12 MHz		–	60	–	$\mu\text{A}$
	50 MHz		–	260	–	$\mu\text{A}$

**Table 11-33. Timer AC Specifications**

Parameter	Description	Conditions	Min	Typ	Max	Units
	Operating frequency		DC	–	50.01	MHz
	Capture pulse width (Internal)		21	–	–	ns
	Capture pulse width (external)		42	–	–	ns
	Timer resolution		21	–	–	ns
	Enable pulse width		21	–	–	ns
	Enable pulse width (external)		42	–	–	ns
	Reset pulse width		21	–	–	ns
	Reset pulse width (external)		42	–	–	ns

#### 11.3.2 Counter

The following specifications apply to the Timer/Counter/PWM peripheral, in counter mode. Counters can also be implemented in UDBs; for more information, see the Counter component datasheet in PSoC Creator.

**Table 11-34. Counter DC Specifications**

Parameter	Description	Conditions	Min	Typ	Max	Units
	Block current consumption	16-bit counter, at listed input clock frequency	–	–	–	$\mu\text{A}$
	3 MHz		–	15	–	$\mu\text{A}$
	12 MHz		–	60	–	$\mu\text{A}$
	50 MHz		–	260	–	$\mu\text{A}$

**Table 11-35. Counter AC Specifications**

Parameter	Description	Conditions	Min	Typ	Max	Units
	Operating frequency		DC	–	50.01	MHz
	Capture pulse		21	–	–	ns
	Resolution		21	–	–	ns
	Pulse width		21	–	–	ns
	Pulse width (external)		42	–	–	ns
	Enable pulse width		21	–	–	ns
	Enable pulse width (external)		42	–	–	ns
	Reset pulse width		21	–	–	ns
	Reset pulse width (external)		42	–	–	ns

### 11.3.3 Pulse Width Modulation

The following specifications apply to the Timer/Counter/PWM peripheral, in PWM mode. PWM components can also be implemented in UDBs; for more information, see the PWM component datasheet in PSoC Creator..

**Table 11-36. PWM DC Specifications**

Parameter	Description	Conditions	Min	Typ	Max	Units
	Block current consumption	16-bit PWM, at listed input clock frequency	–	–	–	μA
	3 MHz		–	15	–	μA
	12 MHz		–	60	–	μA
	50 MHz		–	260	–	μA

**Table 11-37. Pulse Width Modulation (PWM) AC Specifications**

Parameter	Description	Conditions	Min	Typ	Max	Units
	Operating frequency		DC	–	50.01	MHz
	Pulse width		21	–	–	ns
	Pulse width (external)		42	–	–	ns
	Kill pulse width		21	–	–	ns
	Kill pulse width (external)		42	–	–	ns
	Enable pulse width		21	–	–	ns
	Enable pulse width (external)		42	–	–	ns
	Reset pulse width		21	–	–	ns
	Reset pulse width (external)		42	–	–	ns

### 11.3.4 I<sup>2</sup>C

**Table 11-38. Fixed I<sup>2</sup>C DC Specifications**

Parameter	Description	Conditions	Min	Typ	Max	Units
	Block current consumption	Enabled, configured for 100 kbps	–	–	250	μA
		Enabled, configured for 400 kbps	–	–	260	μA
		Wake from sleep mode	–	–	30	μA

**Table 11-39. Fixed I<sup>2</sup>C AC Specifications**

Parameter	Description	Conditions	Min	Typ	Max	Units
	Bit rate		–	–	1	Mbps

### Controller Area Network<sup>[40]</sup>

**Table 11-40. CAN DC Specifications**

Parameter	Description	Conditions	Min	Typ	Max	Units
I <sub>DD</sub>	Block current consumption		–	–	200	μA

**Table 11-41. CAN AC Specifications**

Parameter	Description	Conditions	Min	Typ	Max	Units
	Bit rate	Minimum 8 MHz clock	–	–	1	Mbit

**Note**

40. Refer to ISO 11898 specification for details.

## 11.3.5 USB

**Table 11-42. USB DC Specifications**

Parameter	Description	Conditions	Min	Typ	Max	Units
V <sub>USB_5</sub>	Device supply for USB operation	USB configured, USB regulator enabled	4.35	–	5.25	V
V <sub>USB_3.3</sub>		USB configured, USB regulator bypassed	3.15	–	3.6	V
V <sub>USB_3</sub>		USB configured, USB regulator bypassed <sup>[41]</sup>	2.85	–	3.6	V
I <sub>USB_Configured</sub>	Device supply current in device active mode, bus clock and IMO = 24 MHz	V <sub>DDD</sub> = 5 V, F <sub>CPU</sub> = 1.5 MHz	–	10	–	mA
		V <sub>DDD</sub> = 3.3 V, F <sub>CPU</sub> = 1.5 MHz	–	8	–	mA
I <sub>USB_Suspended</sub>	Device supply current in device sleep mode	V <sub>DDD</sub> = 5 V, connected to USB host, PICU configured to wake on USB resume signal	–	0.5	–	mA
		V <sub>DDD</sub> = 5 V, disconnected from USB host	–	0.3	–	mA
		V <sub>DDD</sub> = 3.3 V, connected to USB host, PICU configured to wake on USB resume signal	–	0.5	–	mA
		V <sub>DDD</sub> = 3.3 V, disconnected from USB host	–	0.3	–	mA

## 11.3.6 Universal Digital Blocks (UDBs)

PSoC Creator provides a library of pre-built and tested standard digital peripherals (UART, SPI, LIN, PRS, CRC, timer, counter, PWM, AND, OR, and so on) that are mapped to the UDB array. See the component datasheets in PSoC Creator for full AC/DC specifications, APIs, and example code.

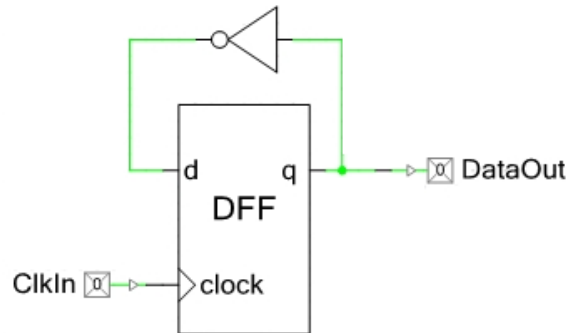
**Table 11-43. UDB AC Specifications**

Parameter	Description	Conditions	Min	Typ	Max	Units
Datapath Performance						
F <sub>MAX_TIMER</sub>	Maximum frequency of 16-bit timer in a UDB pair		–	–	50.01	MHz
F <sub>MAX_ADDER</sub>	Maximum frequency of 16-bit adder in a UDB pair		–	–	50.01	MHz
F <sub>MAX_CRC</sub>	Maximum frequency of 16-bit CRC/PRS in a UDB pair		–	–	50.01	MHz
PLD Performance						
F <sub>MAX_PLD</sub>	Maximum frequency of a two-pass PLD function in a UDB pair		–	–	50.01	MHz
Clock to Output Performance						
t <sub>CLK_OUT</sub>	Propagation delay for clock in to data out, see <a href="#">Figure 11-50</a> .	25 °C, V <sub>DDD</sub> ≥ 2.7 V	–	20	25	ns
t <sub>CLK_OUT</sub>	Propagation delay for clock in to data out, see <a href="#">Figure 11-50</a> .	Worst-case placement, routing, and pin selection	–	–	55	ns

**Note**

41. Rise/fall time matching (TR) not guaranteed, see [USB Driver AC Specifications](#) on page 79.

Figure 11-50. Clock to Output Performance



### 11.4 Memory

Specifications are valid for  $-40\text{ }^{\circ}\text{C} \leq T_A \leq 85\text{ }^{\circ}\text{C}$  and  $T_J \leq 100\text{ }^{\circ}\text{C}$ , except where noted. Specifications are valid for 1.71 V to 5.5 V, except where noted.

#### 11.4.1 Flash

Table 11-44. Flash DC Specifications

Parameter	Description	Conditions	Min	Typ	Max	Units
	Erase and program voltage	V <sub>DDD</sub> pin	1.71	–	5.5	V

Table 11-45. Flash AC Specifications

Parameter	Description	Conditions	Min	Typ	Max	Units
T <sub>WRITE</sub>	Row write time (erase + program)		–	15	20	ms
T <sub>ERASE</sub>	Row erase time		–	10	13	ms
	Row program time		–	5	7	ms
T <sub>BULK</sub>	Bulk erase time (16 KB to 64 KB)		–	–	35	ms
	Sector erase time (8 KB to 16 KB)		–	–	15	ms
	Total device program time, including JTAG or SWD, and other overhead		–	–	5	seconds
	Flash data retention time, retention period measured from last erase cycle	Average ambient temp. T <sub>A</sub> ≤ 55 °C, 100 K erase/program cycles	20	–	–	years
		Average ambient temp. T <sub>A</sub> ≤ 85 °C, 10 K erase/program cycles	10	–	–	

#### 11.4.2 EEPROM

Table 11-46. EEPROM DC Specifications

Parameter	Description	Conditions	Min	Typ	Max	Units
	Erase and program voltage		1.71	–	5.5	V



**Table 11-47. EEPROM AC Specifications**

Parameter	Description	Conditions	Min	Typ	Max	Units
$T_{WRITE}$	Single row erase/write cycle time		–	2	20	ms
	EEPROM data retention time, retention period measured from last erase cycle	Average ambient temp, $T_A \leq 25^\circ\text{C}$ , 1M erase/program cycles	20	–	–	years
		Average ambient temp, $T_A \leq 55^\circ\text{C}$ , 100 K erase/program cycles	20	–	–	
		Average ambient temp. $T_A \leq 85^\circ\text{C}$ , 10 K erase/program cycles	10	–	–	

#### 11.4.3 Nonvolatile Latches (NVL)

**Table 11-48. NVL DC Specifications**

Parameter	Description	Conditions	Min	Typ	Max	Units
	Erase and program voltage	$V_{DD}$ pin	1.71	–	5.5	V

**Table 11-49. NVL AC Specifications**

Parameter	Description	Conditions	Min	Typ	Max	Units
	NVL endurance	Programmed at $25^\circ\text{C}$	1K	–	–	program/erase cycles
		Programmed at $0^\circ\text{C}$ to $70^\circ\text{C}$	100	–	–	program/erase cycles
	NVL data retention time	Programmed at $25^\circ\text{C}$	20	–	–	years
		Programmed at $0^\circ\text{C}$ to $70^\circ\text{C}$	20	–	–	years

#### 11.4.4 SRAM

**Table 11-50. SRAM DC Specifications**

Parameter	Description	Conditions	Min	Typ	Max	Units
$V_{SRAM}$	SRAM retention voltage		1.2	–	–	V

**Table 11-51. SRAM AC Specifications**

Parameter	Description	Conditions	Min	Typ	Max	Units
$F_{SRAM}$	SRAM operating frequency		DC	–	50.01	MHz

11.4.5 External Memory Interface

Figure 11-51. Asynchronous Read Cycle Timing

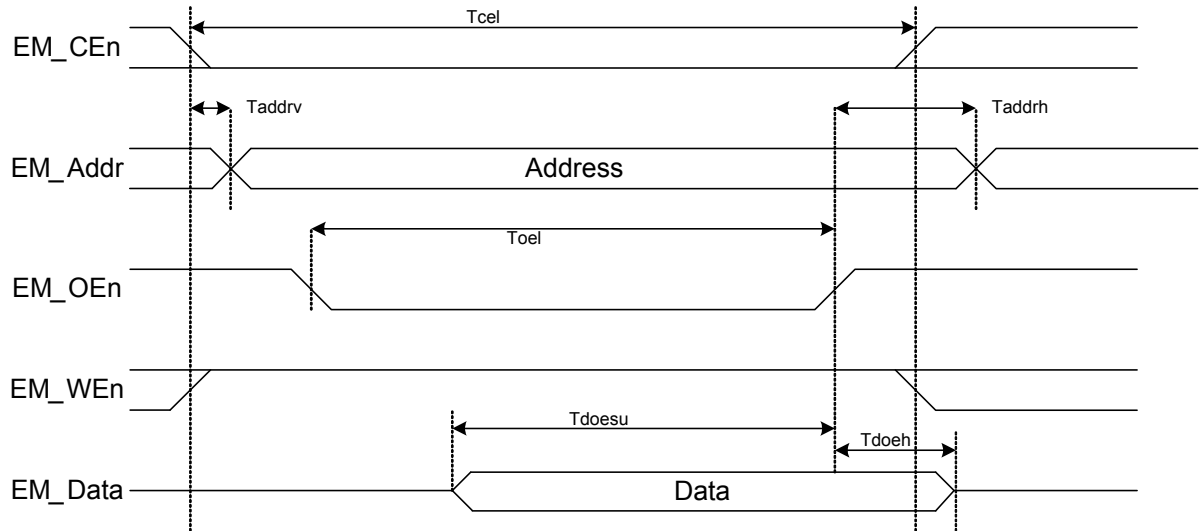
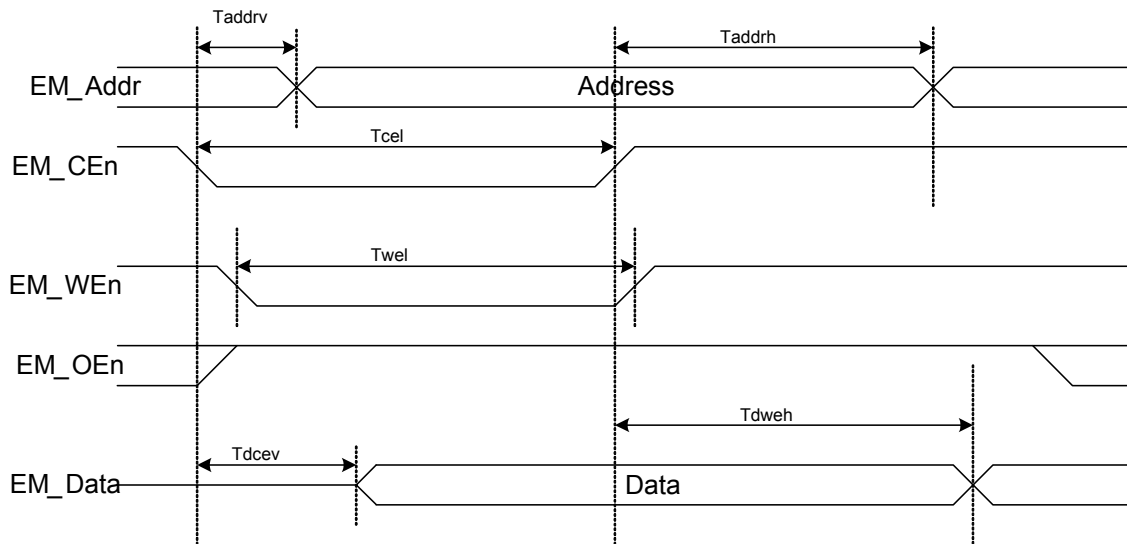


Table 11-52. Asynchronous Read Cycle Specifications

Parameter	Description	Conditions	Min	Typ	Max	Units
T	EMIF clock period <sup>[42]</sup>	V <sub>dda</sub> ≥ 3.3 V	30.3	–	–	nS
T <sub>cel</sub>	EM_CEn low time		2T – 5	–	2T + 5	nS
T <sub>addrv</sub>	EM_CEn low to EM_Addr valid		–	–	5	nS
T <sub>addrh</sub>	Address hold time after EM_Wen high		T	–	–	nS
T <sub>oel</sub>	EM_OEn low time		2T – 5	–	2T + 5	nS
T <sub>doesu</sub>	Data to EM_OEn high setup time		T + 15	–	–	nS
T <sub>doeh</sub>	Data hold time after EM_OEn high		3	–	–	nS

Note

42. Limited by GPIO output frequency, see Table 11-10 on page 74.

**Figure 11-52. Asynchronous Write Cycle Timing**

**Table 11-53. Asynchronous Write Cycle Specifications**

Parameter	Description	Conditions	Min	Typ	Max	Units
T	EMIF clock period <sup>[43]</sup>	V <sub>dda</sub> ≥ 3.3 V	30.3	–	–	nS
T <sub>cel</sub>	EM_CEn low time		T – 5	–	T + 5	nS
T <sub>addrv</sub>	EM_CEn low to EM_Addr valid		–	–	5	nS
T <sub>addrh</sub>	Address hold time after EM_WEn high		T	–	–	nS
T <sub>wel</sub>	EM_WEn low time		T – 5	–	T + 5	nS
T <sub>dcev</sub>	EM_CEn low to data valid		–	–	7	nS
T <sub>dweh</sub>	Data hold time after EM_WEn high		T	–	–	nS

**Note**

43. Limited by GPIO output frequency, see Table 11-10 on page 74.

Figure 11-53. Synchronous Read Cycle Timing

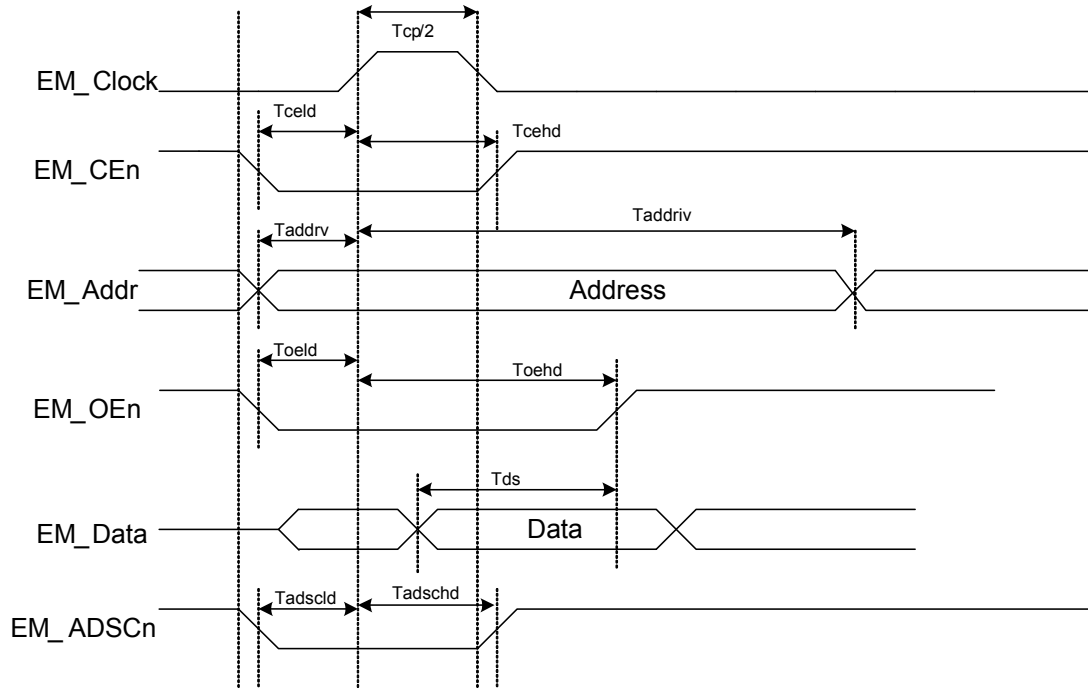


Table 11-54. Synchronous Read Cycle Specifications

Parameter	Description	Conditions	Min	Typ	Max	Units
T	EMIF clock period <sup>[44]</sup>	V <sub>dda</sub> ≥ 3.3 V	30.3	–	–	nS
T <sub>cp/2</sub>	EM_Clock pulse high		T/2	–	–	nS
T <sub>celd</sub>	EM_CEn low to EM_Clock high		5	–	–	nS
T <sub>cehd</sub>	EM_Clock high to EM_CEn high		T/2 – 5	–	–	nS
T <sub>addriv</sub>	EM_Addr valid to EM_Clock high		5	–	–	nS
T <sub>addriv</sub>	EM_Clock high to EM_Addr invalid		T/2 – 5	–	–	nS
T <sub>oeld</sub>	EM_OEn low to EM_Clock high		5	–	–	nS
T <sub>oehd</sub>	EM_Clock high to EM_OEn high		T	–	–	nS
T <sub>ds</sub>	Data valid before EM_OEn high		T + 15	–	–	nS
T <sub>adschd</sub>	EM_ADSCn low to EM_Clock high		5	–	–	nS
T <sub>adschd</sub>	EM_Clock high to EM_ADSCn high		T/2 – 5	–	–	nS

Note

44. Limited by GPIO output frequency, see Table 11-10 on page 74.

Figure 11-54. Synchronous Write Cycle Timing

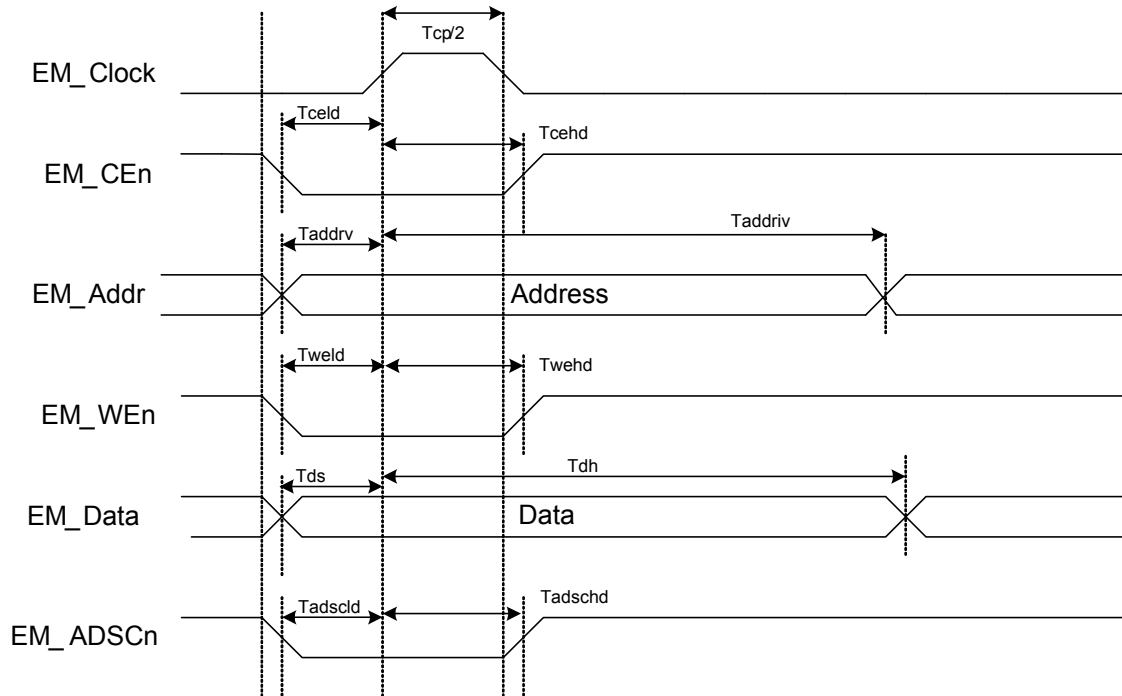


Table 11-55. Synchronous Write Cycle Specifications

Parameter	Description	Conditions	Min	Typ	Max	Units
T	EMIF clock Period <sup>[45]</sup>	V <sub>dda</sub> ≥ 3.3 V	30.3	–	–	nS
Tcp/2	EM_Clock pulse high		T/2	–	–	nS
Tceld	EM_CEn low to EM_Clock high		5	–	–	nS
Tcehd	EM_Clock high to EM_CEn high		T/2 – 5	–	–	nS
Taddrv	EM_Addr valid to EM_Clock high		5	–	–	nS
Taddriv	EM_Clock high to EM_Addr invalid		T/2 – 5	–	–	nS
Tweld	EM_WEn low to EM_Clock high		5	–	–	nS
Twehd	EM_Clock high to EM_WEn high		T/2 – 5	–	–	nS
Tds	Data valid before EM_Clock high		5	–	–	nS
Tdh	Data invalid after EM_Clock high		T	–	–	nS
Tadscl	EM_ADSCn low to EM_Clock high		5	–	–	nS
Tadschd	EM_Clock high to EM_ADSCn high		T/2 – 5	–	–	nS

**Note**

45. Limited by GPIO output frequency, see Table 11-10 on page 74.

## 11.5 PSoC System Resources

Specifications are valid for  $-40\text{ }^{\circ}\text{C} \leq T_A \leq 85\text{ }^{\circ}\text{C}$  and  $T_J \leq 100\text{ }^{\circ}\text{C}$ , except where noted. Specifications are valid for 1.71 V to 5.5 V, except where noted.

### 11.5.1 POR with Brown Out

For brown out detect in regulated mode,  $V_{DDD}$  and  $V_{DDA}$  must be  $\geq 2.0\text{ V}$ . Brown out detect is not available in externally regulated mode.

**Table 11-56. Precise Power-on Reset (PRES) with Brown Out DC Specifications**

Parameter	Description	Conditions	Min	Typ	Max	Units
<b>Precise POR (PPOR)</b>						
PRESR	Rising trip voltage	Factory trim	1.64	–	1.68	V
PRESF	Falling trip voltage		1.62	–	1.66	V

**Table 11-57. Power-on Reset (POR) with Brown Out AC Specifications**

Parameter	Description	Conditions	Min	Typ	Max	Units
PRES_TR	Response time		–	–	0.5	$\mu\text{s}$
	$V_{DDD}/V_{DDA}$ droop rate	Sleep mode	–	5	–	V/sec

### 11.5.2 Voltage Monitors

**Table 11-58. Voltage Monitors DC Specifications**

Parameter	Description	Conditions	Min	Typ	Max	Units
LVI	Trip voltage					
	LVI_A/D_SEL[3:0] = 0000b		1.68	1.73	1.77	V
	LVI_A/D_SEL[3:0] = 0001b		1.89	1.95	2.01	V
	LVI_A/D_SEL[3:0] = 0010b		2.14	2.20	2.27	V
	LVI_A/D_SEL[3:0] = 0011b		2.38	2.45	2.53	V
	LVI_A/D_SEL[3:0] = 0100b		2.62	2.71	2.79	V
	LVI_A/D_SEL[3:0] = 0101b		2.87	2.95	3.04	V
	LVI_A/D_SEL[3:0] = 0110b		3.11	3.21	3.31	V
	LVI_A/D_SEL[3:0] = 0111b		3.35	3.46	3.56	V
	LVI_A/D_SEL[3:0] = 1000b		3.59	3.70	3.81	V
	LVI_A/D_SEL[3:0] = 1001b		3.84	3.95	4.07	V
	LVI_A/D_SEL[3:0] = 1010b		4.08	4.20	4.33	V
	LVI_A/D_SEL[3:0] = 1011b		4.32	4.45	4.59	V
	LVI_A/D_SEL[3:0] = 1100b		4.56	4.70	4.84	V
	LVI_A/D_SEL[3:0] = 1101b		4.83	4.98	5.13	V
	LVI_A/D_SEL[3:0] = 1110b		5.05	5.21	5.37	V
	LVI_A/D_SEL[3:0] = 1111b		5.30	5.47	5.63	V
HVI	Trip voltage		5.57	5.75	5.92	V

**Table 11-59. Voltage Monitors AC Specifications**

Parameter	Description	Conditions	Min	Typ	Max	Units
	Response time		–	–	1	$\mu\text{s}$

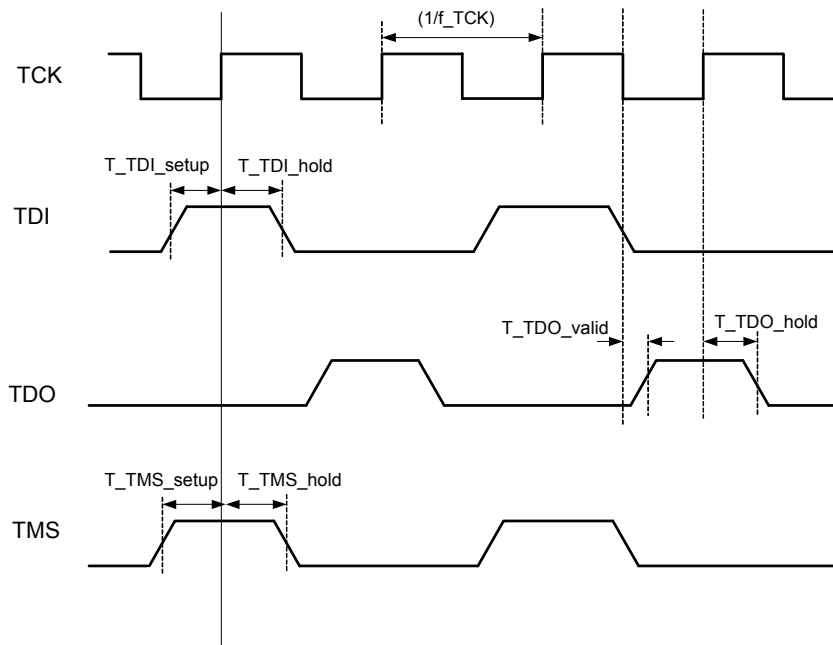
11.5.3 Interrupt Controller

**Table 11-60. Interrupt Controller AC Specifications**

Parameter	Description	Conditions	Min	Typ	Max	Units
	Delay from interrupt signal input to ISR code execution from ISR code	Includes worse case completion of longest instruction DIV with 6 cycles	–	–	25	Tcy CPU

11.5.4 JTAG Interface

**Figure 11-55. JTAG Interface Timing**



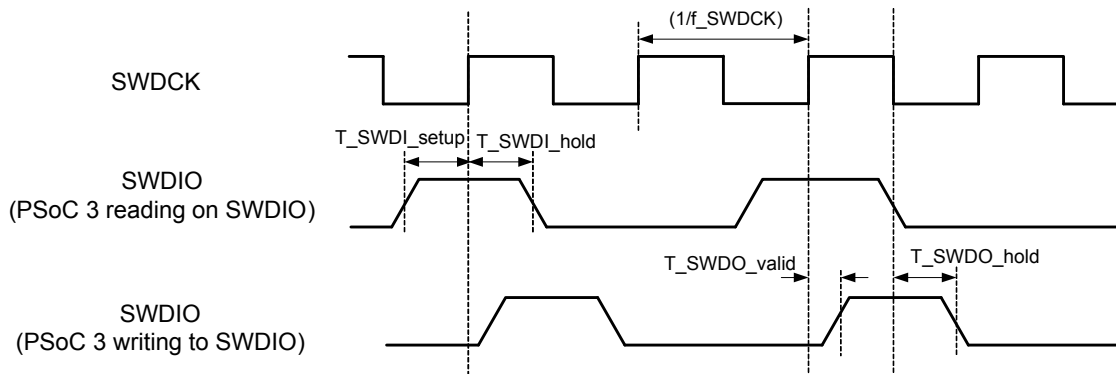
**Table 11-61. JTAG Interface AC Specifications<sup>[46]</sup>**

Parameter	Description	Conditions	Min	Typ	Max	Units
f_TCK	TCK frequency	$3.3\text{ V} \leq V_{\text{DD}} \leq 5\text{ V}$	–	–	14 <sup>[47]</sup>	MHz
		$1.71\text{ V} \leq V_{\text{DD}} < 3.3\text{ V}$	–	–	7 <sup>[47]</sup>	MHz
T_TDI_setup	TDI setup before TCK high		$(T/10) - 5$	–	–	ns
T_TMS_setup	TMS setup before TCK high		T/4	–	–	
T_TDI_hold	TDI, TMS hold after TCK high	$T = 1/f_{\text{TCK}}$ max	T/4	–	–	
T_TDO_valid	TCK low to TDO valid	$T = 1/f_{\text{TCK}}$ max	–	–	2T/5	
T_TDO_hold	TDO hold after TCK high	$T = 1/f_{\text{TCK}}$ max	T/4	–	–	

**Notes**

- 46. Based on device characterization (Not production tested).
- 47. f\_TCK must also be no more than 1/3 CPU clock frequency.

### 11.5.5 SWD Interface

**Figure 11-56. SWD Interface Timing**

**Table 11-62. SWD Interface AC Specifications<sup>[48]</sup>**

Parameter	Description	Conditions	Min	Typ	Max	Units
f_SWDCCK	SWDCLK frequency	$3.3\text{ V} \leq V_{DD} \leq 5\text{ V}$	–	–	14 <sup>[49]</sup>	MHz
		$1.71\text{ V} \leq V_{DD} < 3.3\text{ V}$	–	–	7 <sup>[49]</sup>	MHz
		$1.71\text{ V} \leq V_{DD} < 3.3\text{ V}$ , SWD over USBIO pins	–	–	5.5 <sup>[49]</sup>	MHz
T_SWDI_setup	SWDIO input setup before SWDCK high	$T = 1/f_{SWDCCK}$ max	T/4	–	–	
T_SWDI_hold	SWDIO input hold after SWDCK high	$T = 1/f_{SWDCCK}$ max	T/4	–	–	
T_SWDO_valid	SWDCK high to SWDIO output	$T = 1/f_{SWDCCK}$ max	–	–	2T/5	
T_SWDO_hold	SWDIO output hold after SWDCK low	$T = 1/f_{SWDCCK}$ max	T/4	–	–	

### 11.5.6 SWV Interface

**Table 11-63. SWV Interface AC Specifications<sup>[22]</sup>**

Parameter	Description	Conditions	Min	Typ	Max	Units
	SWV mode SWV bit rate		–	–	33	Mbit

## 11.6 Clocking

Specifications are valid for  $-40\text{ }^{\circ}\text{C} \leq T_A \leq 85\text{ }^{\circ}\text{C}$  and  $T_J \leq 100\text{ }^{\circ}\text{C}$ , except where noted. Specifications are valid for 1.71 V to 5.5 V, except where noted.

### 11.6.1 32 kHz External Crystal

**Table 11-64. 32 kHz External Crystal DC Specifications<sup>[22]</sup>**

Parameter	Description	Conditions	Min	Typ	Max	Units
I <sub>CC</sub>	Operating current	Low-power mode	–	0.25	1.0	μA
CL	External crystal capacitance		–	6	–	pF
DL	Drive level		–	–	1	μW

**Table 11-65. 32 kHz External Crystal AC Specifications**

Parameter	Description	Conditions	Min	Typ	Max	Units
F	Frequency		–	32.768	–	kHz
T <sub>ON</sub>	Startup time	High power mode	–	1	–	s

**Notes**

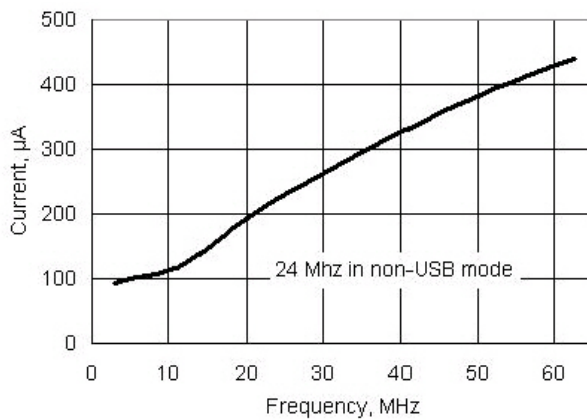
48. Based on device characterization (Not production tested).  
 49. f\_SWDCCK must also be no more than 1/3 CPU clock frequency.



## 11.6.2 Internal Main Oscillator

**Table 11-66. IMO DC Specifications**

Parameter	Description	Conditions	Min	Typ	Max	Units
	Supply current					
	24 MHz – USB mode	With oscillator locking to USB bus	–	–	500	μA
	24 MHz – non USB mode		–	–	300	μA
	12 MHz		–	–	200	μA
	6 MHz		–	–	180	μA
	3 MHz		–	–	150	μA

**Figure 11-57. IMO Current vs. Frequency**

**Table 11-67. IMO AC Specifications**

Parameter	Description	Conditions	Min	Typ	Max	Units
F <sub>IMO</sub>	IMO frequency stability (with factory trim)					
	24 MHz – Non USB mode		–4	–	4	%
	24 MHz – USB mode	With oscillator locking to USB bus	–0.25	–	0.25	%
	12 MHz		–3	–	3	%
	6 MHz		–2	–	2	%
	3 MHz		–1	–	1	%
	Startup time <sup>[50]</sup>	From enable (during normal system operation) or wakeup from low-power state	–	–	12	μs
J <sub>p-p</sub>	Jitter (peak to peak) <sup>[50]</sup>					
	F = 24 MHz		–	0.9	–	ns
	F = 3 MHz		–	1.6	–	ns
J <sub>period</sub>	Jitter (long term) <sup>[50]</sup>					
	F = 24 MHz		–	0.9	–	ns
	F = 3 MHz		–	12	–	ns

**Note**

50. Based on device characterization (Not production tested).

Figure 11-58. IMO Frequency Variation vs. Temperature

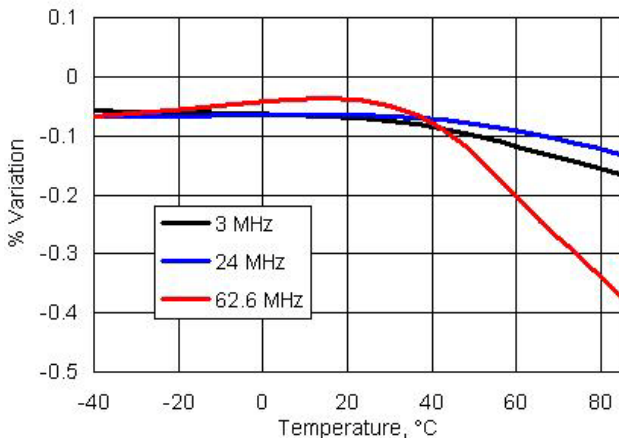
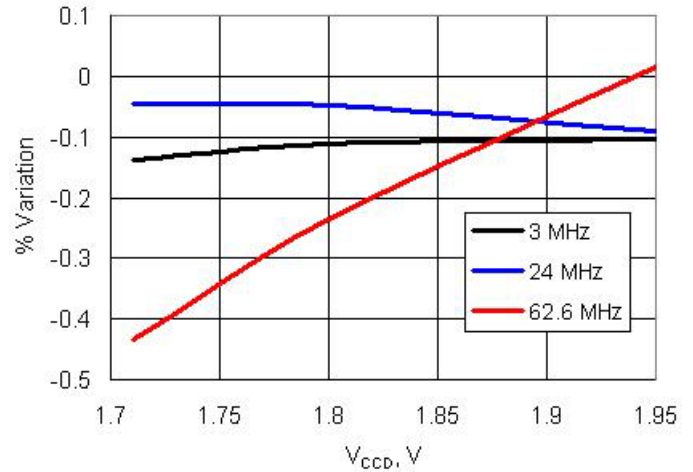


Figure 11-59. IMO Frequency Variation vs. V<sub>CC</sub>



11.6.3 Internal Low-Speed Oscillator

Table 11-68. ILO DC Specifications

Parameter	Description	Conditions	Min	Typ	Max	Units
I <sub>CC</sub>	Operating current	F <sub>OUT</sub> = 1 kHz	–	0.3	1.7	μA
		F <sub>OUT</sub> = 33 kHz	–	1.0	2.6	μA
		F <sub>OUT</sub> = 100 kHz	–	1.0	2.6	μA
	Leakage current	Power down mode	–	2.0	15	nA

Table 11-69. ILO AC Specifications

Parameter	Description	Conditions	Min	Typ	Max	Units
	Startup time, all frequencies	Turbo mode	–	–	2	ms
F <sub>ILO</sub>	ILO frequencies (trimmed)					
		100 kHz	45	100	200	kHz
		1 kHz	0.5	1	2	kHz
	ILO frequencies (untrimmed)					
		100 kHz	30	100	300	kHz
	1 kHz	0.3	1	3.5	kHz	

Figure 11-60. ILO Frequency Variation vs. Temperature

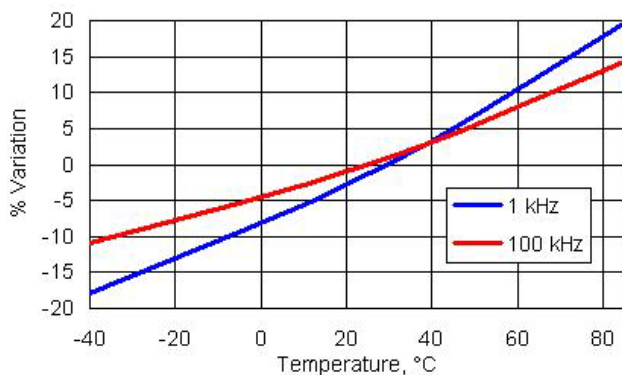
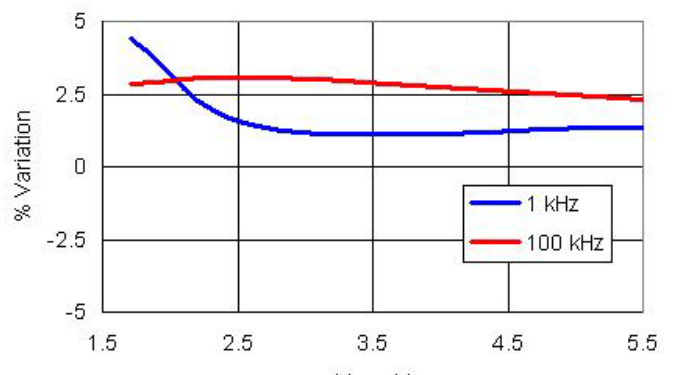


Figure 11-61. ILO Frequency Variation vs. V<sub>DD</sub>



#### 11.6.4 External Crystal Oscillator

**Table 11-70. ECO AC Specifications**

Parameter	Description	Conditions	Min	Typ	Max	Units
F	Crystal frequency range		4	–	25	MHz

#### 11.6.5 External Clock Reference

**Table 11-71. External Clock Reference AC Specifications<sup>[51]</sup>**

Parameter	Description	Conditions	Min	Typ	Max	Units
	External frequency range		0	–	33	MHz
	Input duty cycle range	Measured at $V_{DDIO}/2$	30	50	70	%
	Input edge rate	$V_{IL}$ to $V_{IH}$	0.1	–	–	V/ns

#### 11.6.6 Phase-Locked Loop

**Table 11-72. PLL DC Specifications**

Parameter	Description	Conditions	Min	Typ	Max	Units
$I_{DD}$	PLL operating current	In = 3 MHz, Out = 24 MHz	–	200	–	$\mu$ A

**Table 11-73. PLL AC Specifications**

Parameter	Description	Conditions	Min	Typ	Max	Units
F <sub>pllin</sub>	PLL input frequency <sup>[52]</sup>		1	–	48	MHz
	PLL intermediate frequency <sup>[53]</sup>	Output of prescaler	1	–	3	MHz
F <sub>plout</sub>	PLL output frequency <sup>[52]</sup>		24	–	50	MHz
	Lock time at startup		–	–	250	$\mu$ s
J <sub>period-rms</sub>	Jitter (rms) <sup>[51]</sup>		–	–	250	ps

**Notes**

51. Based on device characterization (Not production tested).

52. This specification is guaranteed by testing the PLL across the specified range using the IMO as the source for the PLL.

53. PLL input divider, Q, must be set so that the input frequency is divided down to the intermediate frequency range. Value for Q ranges from 1 to 16.

## 12. Ordering Information

In addition to the features listed in [Table 12-1](#), every CY8C32 device includes: a precision on-chip voltage reference, precision oscillators, flash, ECC, DMA, a fixed function I<sup>2</sup>C, 4 KB trace RAM, JTAG/SWD programming and debug, external memory interface, and more. In addition to these features, the flexible UDBs and analog subsection support a wide range of peripherals. To assist you in selecting the ideal part, PSoC Creator makes a part recommendation after you choose the components required by your application. All CY8C32 derivatives incorporate device and flash security in user-selectable security levels; see the TRM for details.

**Table 12-1. CY8C32 Family with Single Cycle 8051**

Part Number	MCU Core				Analog								Digital				I/O <sup>[55]</sup>				Package	JTAG ID <sup>[56]</sup>
	CPU Speed (MHz)	Flash (KB)	SRAM (KB)	EEPROM (KB)	LCD Segment Drive	ADC	DAC	Comparator	SC/CT Analog Blocks	Opamps	DFB	CapSense	UDBs <sup>[54]</sup>	16-bit Timer/PWM	FS USB	CAN 2.0b	Total I/O	GPIO	SIO	USBIO		
<b>16 KB Flash</b>																						
CY8C3244AXI-153	50	16	2	0.5	✓	12-bit Del-Sig	1	2	0	0	–	✓	16	4	–	–	70	62	8	0	100-pin TQFP	0×1E099069
CY8C3244LTI-130	50	16	2	0.5	✓	12-bit Del-Sig	1	2	0	0	–	✓	16	4	–	–	46	38	8	0	68-pin QFN	0×1E082069
CY8C3244LTI-123	50	16	2	0.5	✓	12-bit Del-Sig	1	2	0	0	–	✓	16	4	–	–	29	25	4	0	48-pin QFN	0×1E07B069
CY8C3244PVI-133	50	16	2	0.5	✓	12-bit Del-Sig	1	2	0	0	–	✓	16	4	–	–	29	25	4	0	48-pin SSOP	0×1E085069
<b>32 KB Flash</b>																						
CY8C3245AXI-158	50	32	4	1	✓	12-bit Del-Sig	1	2	0	0	–	✓	20	4	–	–	70	62	8	0	100-pin TQFP	0×1E09E069
CY8C3245LTI-163	50	32	4	1	✓	12-bit Del-Sig	1	2	0	0	–	✓	20	4	–	–	46	38	8	0	68-pin QFN	0×1E0A3069
CY8C3245LTI-139	50	32	4	1	✓	12-bit Del-Sig	1	2	0	0	–	✓	20	4	–	–	29	25	4	0	48-pin QFN	0×1E08B069
CY8C3245PVI-134	50	32	4	1	✓	12-bit Del-Sig	1	2	0	0	–	✓	20	4	–	–	29	25	4	0	48-pin SSOP	0×1E086069
CY8C3245AXI-166	50	32	4	1	✓	12-bit Del-Sig	1	2	0	0	–	✓	20	4	✓	–	72	62	8	2	100-pin TQFP	0×1E0A6069
CY8C3245LTI-144	50	32	4	1	✓	12-bit Del-Sig	1	2	0	0	–	✓	20	4	✓	–	31	25	4	2	48-pin QFN	0×1E090069
CY8C3245LTI-129	50	32	4	1	✓	12-bit Del-Sig	1	2	0	0	–	✓	20	4	✓	–	48	38	8	2	68-pin QFN	0×1E081069
CY8C3245PVI-150	50	32	4	1	✓	12-bit Del-Sig	1	2	0	0	–	✓	20	4	✓	–	31	25	4	2	48-pin SSOP	0×1E096069
<b>64 KB Flash</b>																						
CY8C3246LTI-149	50	64	8	2	✓	12-bit Del-Sig	1	2	0	0	–	✓	24	4	–	–	46	38	8	0	68-pin QFN	0×1E095069
CY8C3246PVI-147	50	64	8	2	✓	12-bit Del-Sig	1	2	0	0	–	✓	24	4	✓	–	31	25	4	2	48-pin SSOP	0×1E093069
CY8C3246AXI-131	50	64	8	2	✓	12-bit Del-Sig	1	2	0	0	–	✓	24	4	–	–	70	62	8	0	100-pin TQFP	0×1E083069
CY8C3246LTI-162	50	64	8	2	✓	12-bit Del-Sig	1	2	0	0	–	✓	24	4	–	–	29	25	4	0	48-pin QFN	0×1E0A2069
CY8C3246PVI-122	50	64	8	2	✓	12-bit Del-Sig	1	2	0	0	–	✓	24	4	–	–	29	25	4	0	48-pin SSOP	0×1E07A069
CY8C3246AXI-138	50	64	8	2	✓	12-bit Del-Sig	1	2	0	0	–	✓	24	4	✓	–	72	62	8	2	100-pin TQFP	0×1E08A069
CY8C3246LTI-128	50	64	8	2	✓	12-bit Del-Sig	1	2	0	0	–	✓	24	4	✓	–	48	38	8	2	68-pin QFN	0×1E080069
CY8C3246LTI-125	50	64	8	2	✓	12-bit Del-Sig	1	2	0	0	–	✓	24	4	✓	–	31	25	4	2	48-pin QFN	0×1E07D069

### Notes

- UDBs support a wide variety of functionality including SPI, LIN, UART, timer, counter, PWM, PRS, and others. Individual functions may use a fraction of a UDB or multiple UDBs. Multiple functions can share a single UDB. See the [Example Peripherals](#) on page 41 for more information on how UDBs can be used.
- The I/O Count includes all types of digital I/O: GPIO, SIO, and the two USB I/O. See the [I/O System and Routing](#) on page 34 for details on the functionality of each of these types of I/O.
- The JTAG ID has three major fields. The most significant nibble (left digit) is the version, followed by a 2 byte part number and a 3 nibble manufacturer ID.

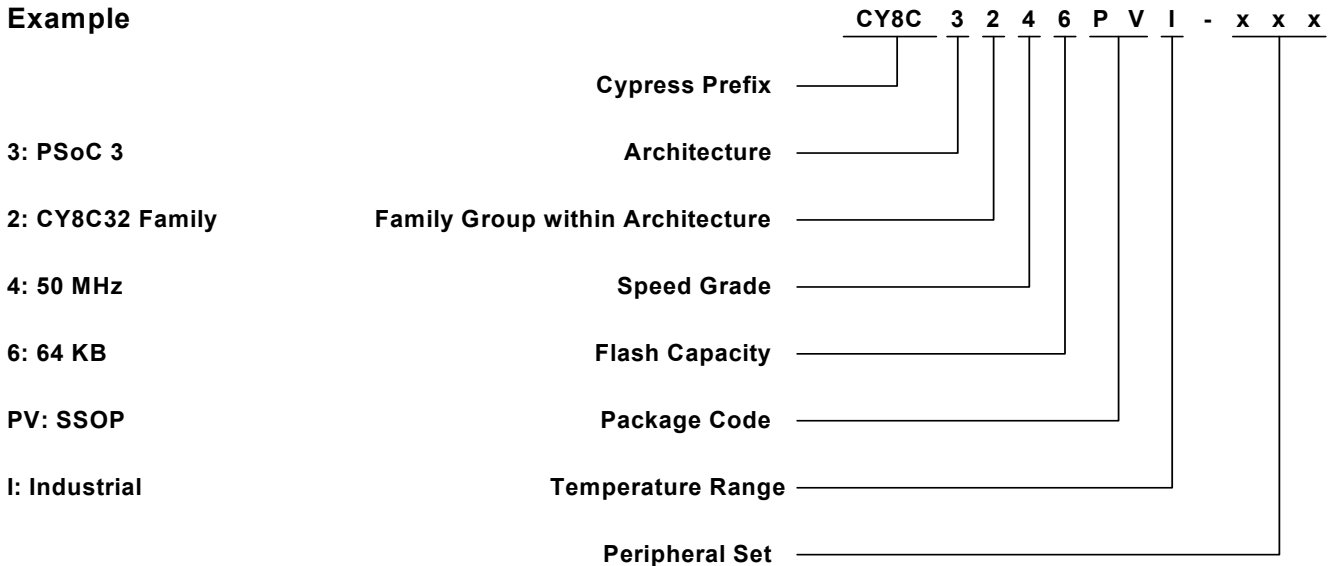
**12.1 Part Numbering Conventions**

PSoC 3 devices follow the part numbering convention described here. All fields are single character alphanumeric (0, 1, 2, ..., 9, A, B, ..., Z) unless stated otherwise.

CY8Cabcdefg-xxx

- a: Architecture
  - 3: PSoC 3
  - 5: PSoC 5
- b: Family group within architecture
  - 2: CY8C32 family
  - 4: CY8C34 family
  - 6: CY8C36 family
  - 8: CY8C38 family
- c: Speed grade
  - 4: 50 MHz
  - 6: 67 MHz
- d: Flash capacity
  - 4: 16 KB
  - 5: 32 KB
  - 6: 64 KB
- ef: Package code
  - Two character alphanumeric
  - AX: TQFP
  - LT: QFN
  - PV: SSOP
- g: Temperature range
  - C: commercial
  - I: industrial
  - A: automotive
- xxx: Peripheral set
  - Three character numeric
  - No meaning is associated with these three characters.

**Example**



All devices in the PSoC 3 CY8C32 family comply to RoHS-6 specifications, demonstrating the commitment by Cypress to lead-free products. Lead (Pb) is an alloying element in solders that has resulted in environmental concerns due to potential toxicity. Cypress uses nickel-palladium-gold (NiPdAu) technology for the majority of leadframe-based packages.

A high level review of the Cypress Pb-free position is available on our website. Specific package information is also available. Package Material Declaration Datasheets (PMDDs) identify all substances contained within Cypress packages. PMDDs also confirm the absence of many banned substances. The information in the PMDDs will help Cypress customers plan for recycling or other “end of life” requirements.

### 13. Packaging

**Table 13-1. Package Characteristics**

Parameter	Description	Conditions	Min	Typ	Max	Units
T <sub>A</sub>	Operating ambient temperature		-40	25.00	85	°C
T <sub>J</sub>	Operating junction temperature		-40	-	100	°C
T <sub>JA</sub>	Package $\theta_{JA}$ (48-pin SSOP)		-	49	-	°C/Watt
T <sub>JA</sub>	Package $\theta_{JA}$ (48-pin QFN)		-	14	-	°C/Watt
T <sub>JA</sub>	Package $\theta_{JA}$ (68-pin QFN)		-	15	-	°C/Watt
T <sub>JA</sub>	Package $\theta_{JA}$ (100-pin TQFP)		-	34	-	°C/Watt
T <sub>JC</sub>	Package $\theta_{JC}$ (48-pin SSOP)		-	24	-	°C/Watt
T <sub>JC</sub>	Package $\theta_{JC}$ (48-pin QFN)		-	15	-	°C/Watt
T <sub>JC</sub>	Package $\theta_{JC}$ (68-pin QFN)		-	13	-	°C/Watt
T <sub>JC</sub>	Package $\theta_{JC}$ (100-pin TQFP)		-	10	-	°C/Watt

**Table 13-2. Solder Reflow Peak Temperature**

Package	Maximum Peak Temperature	Maximum Time at Peak Temperature
48-pin SSOP	260 °C	30 seconds
48-pin QFN	260 °C	30 seconds
68-pin QFN	260 °C	30 seconds
100-pin TQFP	260 °C	30 seconds

**Table 13-3. Package Moisture Sensitivity Level (MSL), IPC/JEDEC J-STD-2**

Package	MSL
48-pin SSOP	MSL 3
48-pin QFN	MSL 3
68-pin QFN	MSL 3
100-pin TQFP	MSL 3

Figure 13-1. 48-pin (300 mil) SSOP Package Outline

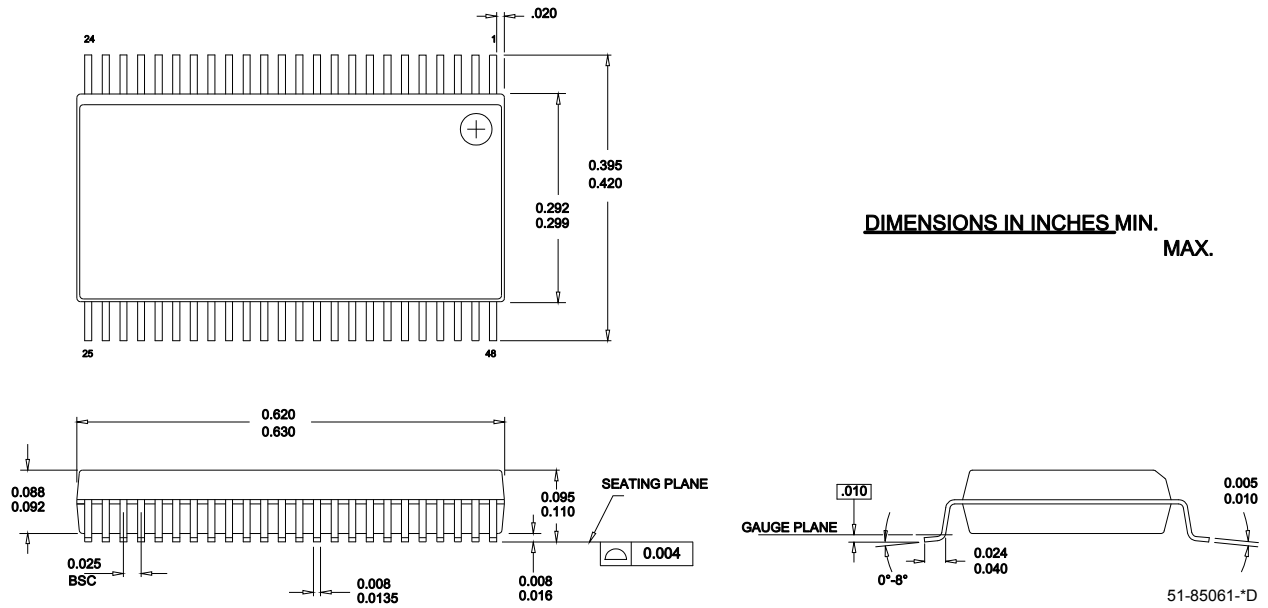
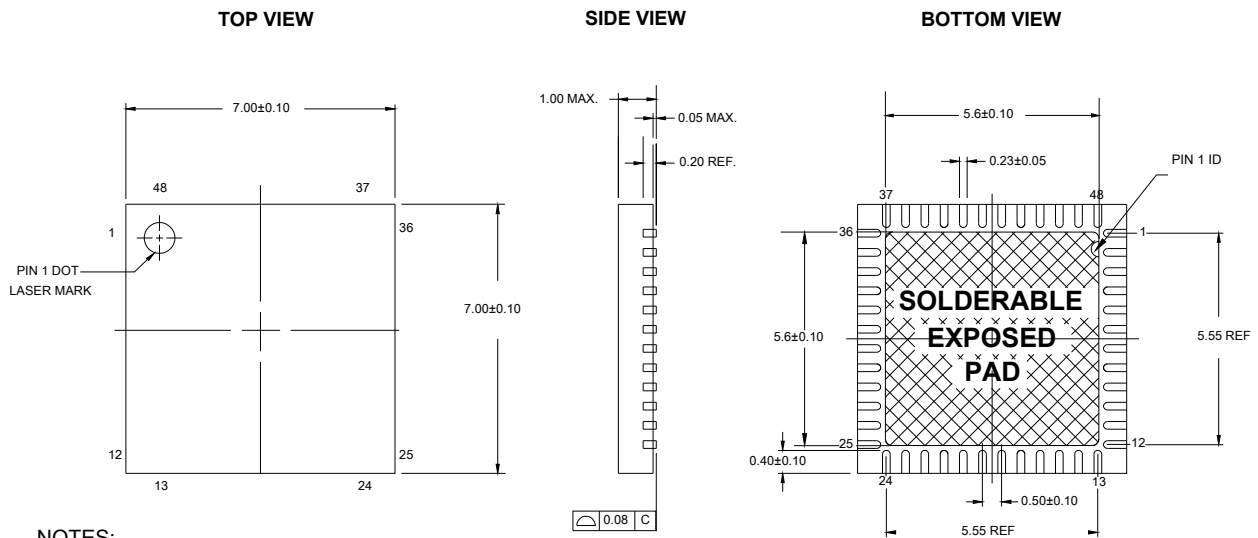


Figure 13-2. 48-pin QFN Package Outline



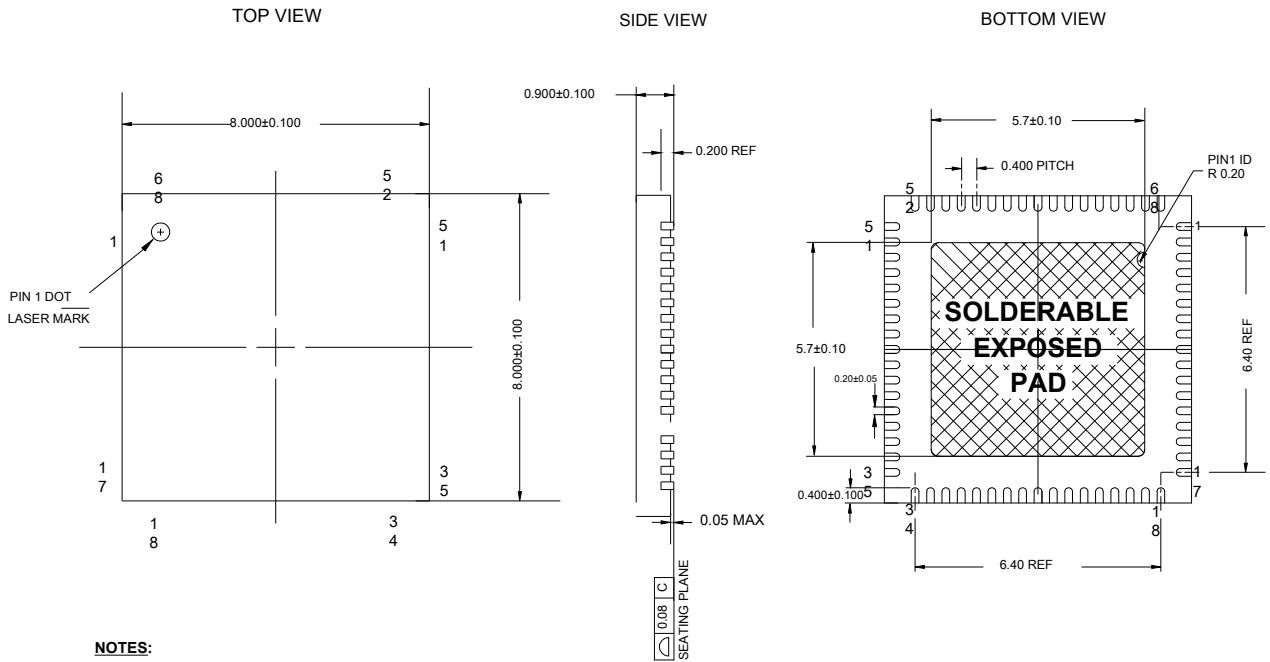
NOTES:

- 1. HATCH AREA IS SOLDERABLE EXPOSED METAL.
- 2. REFERENCE JEDEC#: MO-220
- 3. PACKAGE WEIGHT: 0.13g
- 4. ALL DIMENSIONS ARE IN MM [MIN/MAX]
- 5. PACKAGE CODE


PART #	DESCRIPTION
LT48D	LEAD FREE

001-45616 \*B

Figure 13-3. 68-pin QFN 8x8 with 0.4 mm Pitch Package Outline (Sawn Version)

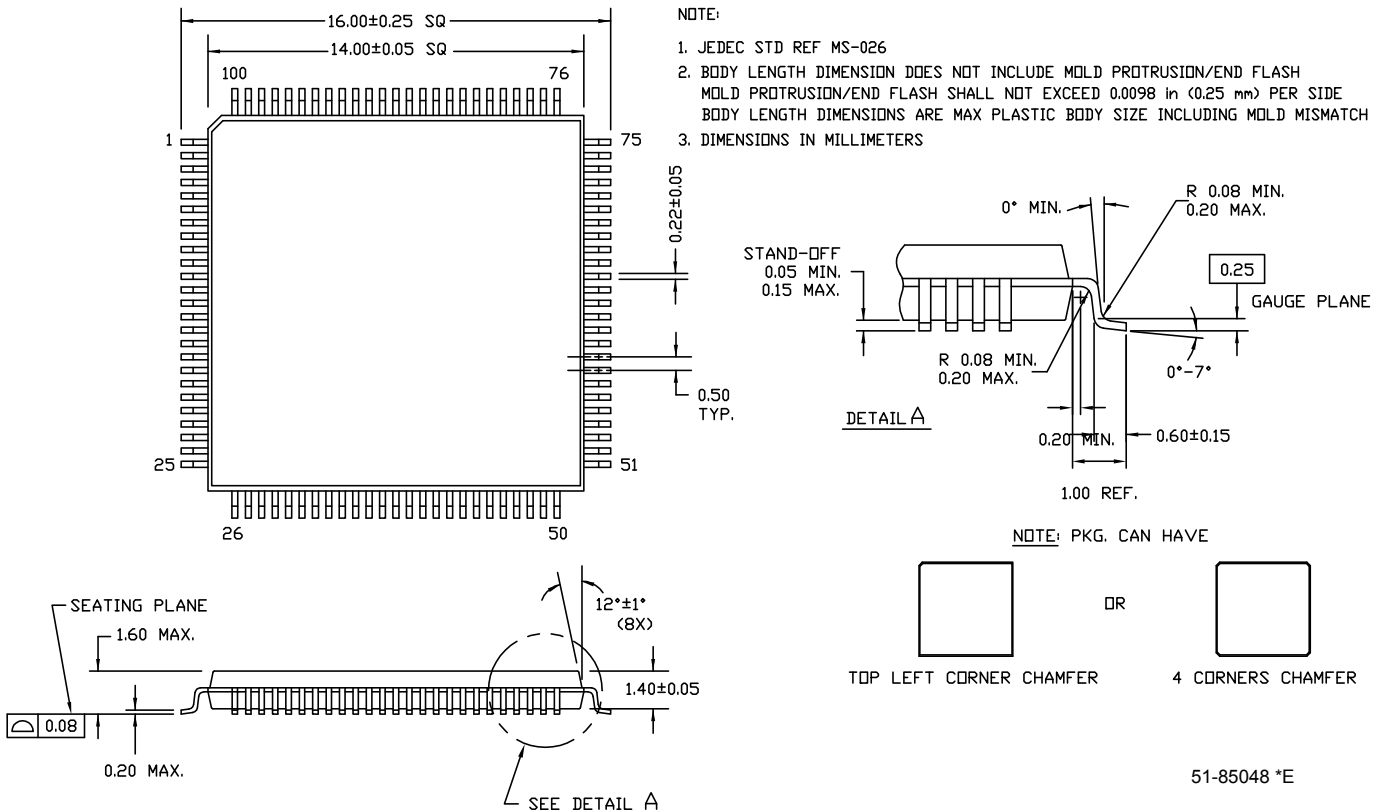


NOTES:

1.  HATCH AREA IS SOLDERABLE EXPOSED METAL.
2. REFERENCE JEDEC#: MO-220
3. PACKAGE WEIGHT: 0.17g
4. ALL DIMENSIONS ARE IN MILLIMETERS

001-09618 \*C

Figure 13-4. 100-pin TQFP (14 × 14 × 1.4 mm) Package Outline





## 14. Acronyms

**Table 14-1. Acronyms Used in this Document**

Acronym	Description
abus	analog local bus
ADC	analog-to-digital converter
AG	analog global
AHB	AMBA (advanced microcontroller bus architecture) high-performance bus, an ARM data transfer bus
ALU	arithmetic logic unit
AMUXBUS	analog multiplexer bus
API	application programming interface
APSR	application program status register
ARM®	advanced RISC machine, a CPU architecture
ATM	automatic thump mode
BW	bandwidth
CAN	Controller Area Network, a communications protocol
CMRR	common-mode rejection ratio
CPU	central processing unit
CRC	cyclic redundancy check, an error-checking protocol
DAC	digital-to-analog converter, see also IDAC, VDACC
DFB	digital filter block
DIO	digital input/output, GPIO with only digital capabilities, no analog. See GPIO.
DMA	direct memory access, see also TD
DNL	differential nonlinearity, see also INL
DNU	do not use
DR	port write data registers
DSI	digital system interconnect
DWT	data watchpoint and trace
ECC	error correcting code
ECO	external crystal oscillator
EEPROM	electrically erasable programmable read-only memory
EMI	electromagnetic interference
EMIF	external memory interface
EOC	end of conversion
EOF	end of frame
EPSR	execution program status register
ESD	electrostatic discharge
ETM	embedded trace macrocell

**Table 14-1. Acronyms Used in this Document (continued)**

Acronym	Description
FIR	finite impulse response, see also IIR
FPB	flash patch and breakpoint
FS	full-speed
GPIO	general-purpose input/output, applies to a PSoC pin
HVI	high-voltage interrupt, see also LVI, LVD
IC	integrated circuit
IDAC	current DAC, see also DAC, VDACC
IDE	integrated development environment
I <sup>2</sup> C, or IIC	Inter-Integrated Circuit, a communications protocol
IIR	infinite impulse response, see also FIR
ILO	internal low-speed oscillator, see also IMO
IMO	internal main oscillator, see also ILO
INL	integral nonlinearity, see also DNL
I/O	input/output, see also GPIO, DIO, SIO, USBIO
IPOR	initial power-on reset
IPSR	interrupt program status register
IRQ	interrupt request
ITM	instrumentation trace macrocell
LCD	liquid crystal display
LIN	Local Interconnect Network, a communications protocol.
LR	link register
LUT	lookup table
LVD	low-voltage detect, see also LVI
LVI	low-voltage interrupt, see also HVI
LVTTTL	low-voltage transistor-transistor logic
MAC	multiply-accumulate
MCU	microcontroller unit
MISO	master-in slave-out
NC	no connect
NMI	nonmaskable interrupt
NRZ	non-return-to-zero
NVIC	nested vectored interrupt controller
NVL	nonvolatile latch, see also WOL
opamp	operational amplifier
PAL	programmable array logic, see also PLD
PC	program counter
PCB	printed circuit board
PGA	programmable gain amplifier

**Table 14-1. Acronyms Used in this Document** *(continued)*

Acronym	Description
PHUB	peripheral hub
PHY	physical layer
PICU	port interrupt control unit
PLA	programmable logic array
PLD	programmable logic device, see also PAL
PLL	phase-locked loop
PMDD	package material declaration datasheet
POR	power-on reset
PRES	precise power-on reset
PRS	pseudo random sequence
PS	port read data register
PSoC®	Programmable System-on-Chip™
PSRR	power supply rejection ratio
PWM	pulse-width modulator
RAM	random-access memory
RISC	reduced-instruction-set computing
RMS	root-mean-square
RTC	real-time clock
RTL	register transfer language
RTR	remote transmission request
RX	receive
SAR	successive approximation register
SC/CT	switched capacitor/continuous time
SCL	I <sup>2</sup> C serial clock
SDA	I <sup>2</sup> C serial data
S/H	sample and hold
SINAD	signal to noise and distortion ratio
SIO	special input/output, GPIO with advanced features. See GPIO.
SOC	start of conversion

**Table 14-1. Acronyms Used in this Document** *(continued)*

Acronym	Description
SOF	start of frame
SPI	Serial Peripheral Interface, a communications protocol
SR	slew rate
SRAM	static random access memory
SRES	software reset
SWD	serial wire debug, a test protocol
SWV	single-wire viewer
TD	transaction descriptor, see also DMA
THD	total harmonic distortion
TIA	transimpedance amplifier
TRM	technical reference manual
TTL	transistor-transistor logic
TX	transmit
UART	Universal Asynchronous Transmitter Receiver, a communications protocol
UDB	universal digital block
USB	Universal Serial Bus
USBIO	USB input/output, PSoC pins used to connect to a USB port
VDAC	voltage DAC, see also DAC, IDAC
WDT	watchdog timer
WOL	write once latch, see also NVL
WRES	watchdog timer reset
XRES	external reset I/O pin
XTAL	crystal

## 15. Reference Documents

[PSoC® 3, PSoC® 5 Architecture TRM](#)

[PSoC® 3 Registers TRM](#)

## 16. Document Conventions

### 16.1 Units of Measure

**Table 16-1. Units of Measure**

Symbol	Unit of Measure
°C	degrees Celsius
dB	decibels
fF	femtofarads
Hz	hertz
KB	1024 bytes
kbps	kilobits per second
Khr	kilohours
kHz	kilohertz
kΩ	kilohms
ksps	kilosamples per second
LSB	least significant bit
Mbps	megabits per second
MHz	megahertz
MΩ	megaohms
Msp	megasamples per second
μA	microamperes

**Table 16-1. Units of Measure (continued)**

Symbol	Unit of Measure
μF	microfarads
μH	microhenrys
μs	microseconds
μV	microvolts
μW	microwatts
mA	milliamperes
ms	milliseconds
mV	millivolts
nA	nanoamperes
ns	nanoseconds
nV	nanovolts
Ω	ohms
pF	picofarads
ppm	parts per million
ps	picoseconds
s	seconds
sps	samples per second
sqrtHz	square root of hertz
V	volts

## 17. Revision History

Description Title: PSoC <sup>®</sup> 3: CY8C32 Family Data Sheet Programmable System-on-Chip (PSoC <sup>®</sup> ) Document Number: 001-56955				
Rev.	ECN No.	Submission Date	Orig. of Change	Description of Change
**	2796903	11/04/09	MKEA	New datasheet
*A	2824546	12/09/09	MKEA	Updated I2C section to reflect 1 Mbps. Updated Table 11-6 and 11- 7 (Boost AC and DC specs); also added Shottky Diode specs. Changed current for sleep/hibernate mode to include SIO; Added footnote to analog global specs. Updated Figures 1-1, 6-2, 7-14, and 8-1. Updated Table 6-2 and Table 6-3 (Hibernate and Sleep rows) and Power Modes section. Updated GPIO and SIO AC specifications. Updated Gain error in IDAC and VDAC specifications. Updated description of V <sub>DDA</sub> spec in Table 11-1 and removed GPIO Clamp Current parameter. Updated number of UDBs on page 1. Moved FILO from ILO DC to AC table. Added PCB Layout and PCB Schematic diagrams. Updated Fgpiout spec (Table 11-9). Added duty cycle frequency in PLL AC spec table. Added note for Sleep and Hibernate modes and Active Mode specs in Table 11-2. Linked URL in Section 10.3 to PSoC Creator site. Updated Ja and Jc values in Table 13-1. Updated Single Sample Mode and Fast FIR Mode sections. Updated Input Resistance specification in Del-Sig ADC table. Added Tio_init parameter. Updated PGA and UGB AC Specs. Removed SPC ADC. Updated Boost Converter section. Added section 'SIO as Comparator'; updated Hysteresis spec (differential mode) in Table 11-10. Updated V <sub>BAT</sub> condition and deleted Vstart parameter in Table 11-6. Added 'Bytes' column for Tables 4-1 to 4-5.
*B	2873322	02/04/10	MKEA	Changed maximum value of PPOR_TR to '1'. Updated V <sub>BIAS</sub> specification. Updated PCB Schematic. Updated Figure 8-1 and Figure 6-3. Updated Interrupt Vector table, Updated Sales links. Updated JTAG and SWD specifications. Removed Jp-p and Jperiod from ECO AC Spec table. Added note on sleep timer in Table 11-2. Updated ILO AC and DC specifications. Added Resolution parameter in VDAC and IDAC tables. Updated I <sub>OUT</sub> typical and maximum values. Changed Temperature Sensor range to -40 °C to +85 °C. Removed Latchup specification from Table 11-1. Updated DAC details

**Description Title: PSoC<sup>®</sup> 3: CY8C32 Family Data Sheet Programmable System-on-Chip (PSoC<sup>®</sup>)  
Document Number: 001-56955**

*C	2903576	04/01/10	MKEA	<p>Updated Vb pin in PCB Schematic.</p> <p>Updated Tstartup parameter in AC Specifications table.</p> <p>Added Load regulation and Line regulation parameters to Inductive Boost Regulator DC Specifications table.</p> <p>Updated I<sub>CC</sub> parameter in LCD Direct Drive DC Specs table.</p> <p>In page 1, updated internal oscillator range under Precision programmable clocking to start from 3 MHz.</p> <p>Updated I<sub>OUT</sub> parameter in LCD Direct Drive DC Specs table.</p> <p>Updated Table 6-2 and Table 6-3.</p> <p>Added bullets on CapSense in page 1; added CapSense column in Section 12 Rem</p> <p>oved some references to footnote [1].</p> <p>Changed INC_Rn cycles from 3 to 2 (Table 4-1).</p> <p>Added footnote in PLL AC Specification table.</p> <p>Added PLL intermediate frequency row with footnote in PLL AC Specs table.</p> <p>Added UDBs subsection under 11.6 Digital Peripherals.</p> <p>Updated Figure 2-6 (PCB Layout).</p> <p>Updated Pin Descriptions section and modified Figures 6-6, 6-8, 6-9.</p> <p>Updated LVD in Tables 6-2 and 6-3; modified Low-power modes bullet in page 1.</p> <p>Added note to Figures 2-5 and 6-2; Updated Figure 6-2 to add capacitors for V<sub>DDA</sub> and V<sub>DDD</sub> pins.</p> <p>Updated boost converter section (6.2.2).</p> <p>Updated Tstartup values in Table 11-3.</p> <p>Removed IPOR rows from Table 11-53. Updated 6.3.1.1, Power Voltage Level Monitors.</p> <p>Updated section 5.2 and Table 11-2 to correct suggestion of execution from flash.</p> <p>Updated IMO max frequency in Figure 6-1, Table 11-63, and Table 11-64.</p> <p>Updated V<sub>REF</sub> specs in Table 11-19.</p> <p>Updated IDAC uncompensated gain error in Table 11-23.</p> <p>Updated Delay from Interrupt signal input to ISR code execution from ISR code in Table-71. Removed other line in table.</p> <p>Added sentence to last paragraph of section 6.1.1.3.</p> <p>Updated Tresp, high and low-power modes, in Table 11-22.</p> <p>Updated f<sub>TCK</sub> values in Table 11-58 and f<sub>SWDCK</sub> values in Table 11-59.</p> <p>Updated SNR condition in Table 11-18.</p> <p>Updated sleep wakeup time in Table 6-3 and Tsleep in Table 11-3.</p> <p>Added 1.71 V ≤ V<sub>DDD</sub> &lt; 3.3 V, SWD over USBIO pins value to Table 11-59.</p> <p>Removed mention of hibernate reset (HRES) from page 1 features, Table 6-3, Section 6.2.1.4, Section 6.3, and Section 6.3.1.1. Change PPOR/PRES to TBDs in Section 6.3.1.1, Section 6.4.1.6 (changed PPOR to reset), Table 11-3 (changed PPOR to PRES), Table 11-53 (changed title, values TBD), and Table 11-54 (changed PPOR_TR to PRES_TR).</p> <p>Added sentence saying that LVD circuits can generate a reset to Section 6.3.1.1.</p> <p>Changed I<sub>DD</sub> values on page 1, page 5, and Table 11-2.</p> <p>Changed resume time value in Section 6.2.1.3.</p> <p>Changed ESD HBM value in Table 11-1.</p> <p>Changed sample rate row in Table 11-18.</p> <p>Removed V<sub>DDA</sub> = 1.65 V rows and changed BWag value in Table 11-20.</p> <p>Changed Vioff values and changed CMRR value in Table 11-21.</p> <p>Changed INL max value in Table 11-25.</p> <p>Changed occurrences of “Block” to “Row” and deleted the “ECC not included” footnote in Table 11-41.</p> <p>Changed max response time value in Tables 11-54 and 11-56.</p> <p>Change the Startup time in Table 11-64.</p> <p>Added condition to intermediate frequency row in Table 11-70.</p> <p>Added row to Table 11-54.</p> <p>Added brown out note to Section 11.8.1.</p>
----	---------	----------	------	--

**Description Title: PSoC<sup>®</sup> 3: CY8C32 Family Data Sheet Programmable System-on-Chip (PSoC<sup>®</sup>)  
Document Number: 001-56955**

*D	2938381	05/27/10	MKEA	<p>Replaced V<sub>DDIO</sub> with V<sub>DDD</sub> in USBIO diagram and specification tables, added text in USBIO section of Electrical Specifications.</p> <p>Added Table 13-2 (Package MSL)</p> <p>Modified Tstorag condition and changed max spec to 100</p> <p>Added bullet (Pass) under ALU (section 7.2.2.2)</p> <p>Added figures for kHzECO and MHzECO in the External Oscillator section</p> <p>Updated Figure 6-1(Clocking Subsystem diagram)</p> <p>Removed CPUCLK_DIV in table 5-2, Deleted Clock Divider SFR subsection</p> <p>Updated PSoC Creator Framework image</p> <p>Updated SIO DC Specifications (V<sub>IH</sub> and V<sub>IL</sub> parameters)</p> <p>Updated bullets in Clocking System and Clocking Distribution sections</p> <p>Updated Figure 8-2</p> <p>Updated Table 11-10</p> <p>Updated PCB Layout and Schematic, updated as per MTRB review comments</p> <p>Updated Table 6-3 (power changed to current)</p> <p>In 32kHz EC DC Specifications table, changed I<sub>CC</sub> Max to 0.25</p> <p>In IMO DC Specifications table, updated Supply Current values</p> <p>Updated GPIO DC Specs table</p> <p>Modified to support a maximum 50MHz CPU speed</p>
*E	2958674	06/22/10	SHEA	<p>Minor ECN to post datasheet to external website</p>
*F	2989685	08/04/10	MKEA	<p>Added USBIO 22 ohm DP and DM resistors to Simplified Block Diagram</p> <p>Added to Table 6-6 a footnote and references to same.</p> <p>Added sentences to the resistive pull-up and pull-down description bullets.</p> <p>Added sentence to Section 6.4.11, Adjustable Output Level.</p> <p>Updated section 5.5 External Memory Interface</p> <p>Updated Table 11-73 JTAG Interface AC Specifications</p> <p>Updated Table 11-74 SWD Interface AC Specifications</p>
*G	3078568	11/04/10	MKEA	<p>Updated "Current Digital-to-analog Converter (IDAC)" on page 84</p> <p>Updated "Voltage Digital to Analog Converter (VDAC)" on page 89</p> <p>Updated Table 11-2, "DC Specifications," on page 65</p>
*H	3107314	12/10/2010	MKEA	<p>Updated delta-sigma tables and graphs.</p> <p>Updated Flash AC specs</p> <p>Formatted table 11.2.</p> <p>Updated interrupt controller table</p> <p>Updated transimpedance amplifier section</p> <p>Updated SIO DC specs table</p> <p>Updated Voltage Monitors DC Specifications table</p> <p>Updated LCD Direct Drive DC specs table</p> <p>Updated ESD<sub>HBM</sub> value.</p> <p>Updated IDAC and VDAC sections</p> <p>Removed ESO parts from ordering information</p> <p>Changed USBIO pins from NC to DNU and removed redundant USBIO pin description notes</p> <p>Updated POR with brown out DC and AC specs</p> <p>Updated 32 kHz External Crystal DC Specifications</p> <p>Updated XRES IO specs</p> <p>Updated Inductive boost regulator section</p> <p>Delta sigma ADC spec updates</p> <p>Updated comparator section</p> <p>Removed buzz mode from Power Mode Transition diagram</p>
*I	3179219	02/22/2011	MKEA	<p>Updated conditions for flash data retention time.</p> <p>Updated 100-pin TQFP package spec.</p> <p>Updated EEPROM AC specifications.</p>

**Description Title: PSoC® 3: CY8C32 Family Data Sheet Programmable System-on-Chip (PSoC®)**  
**Document Number: 001-56955**

*J	3200146	03/28/2011	MKEA	<p>Removed Preliminary status from the data sheet.  Updated JTAG ID  Deleted Cin_G1, ADC input capacitance from Delta-Sigma ADC DC spec table  Updated JTAG Interface AC Specifications and SWD Interface Specifications tables  Updated USBIO DC specs  Added 0.01 to max speed  Updated Features on page 1  Added Section 5.5, Nonvolatile Latches  Updated Flash AC specs  Updated delta-sigma graphs, noise histogram figures and RMS Noise spec tables  Add reference to application note AN58304 in section 8.1  Updated 100-pin TQFP package spec  Added oscillator, I/O, VDAC, regulator graphs  Updated JTAG/SWD timing diagrams  Updated GPIO and SIO AC specs  Updated POR with Brown Out AC spec table  Updated IDAC graphs  Added DMA timing diagram, interrupt timing and interrupt vector, I2C timing diagrams  Added full chip performance graphs  Changed MHzECO range.  Added "Solder Reflow Peak Temperature" table.</p>
*K	3259185	05/17/2011	MKEA	<p>Added JTAG and SWD interface connection diagrams  Updated T<sub>JA</sub> and T<sub>JC</sub> values in Table 13-1  Changed typ and max values for the TC<sub>Vos</sub> parameter in Opamp DC specifications table.  Updated Clocking subsystem diagram.  Changed V<sub>ssd</sub> to V<sub>ssb</sub> in the PSoC Power System diagram  Updated Ordering information.</p>

## 18. Sales, Solutions, and Legal Information

### Worldwide Sales and Design Support

Cypress maintains a worldwide network of offices, solution centers, manufacturers' representatives, and distributors. To find the office closest to you, visit us at [Cypress Locations](#).

#### Products

Automotive	<a href="http://cypress.com/go/automotive">cypress.com/go/automotive</a>
Clocks & Buffers	<a href="http://cypress.com/go/clocks">cypress.com/go/clocks</a>
Interface	<a href="http://cypress.com/go/interface">cypress.com/go/interface</a>
Lighting & Power Control	<a href="http://cypress.com/go/powerpsoc">cypress.com/go/powerpsoc</a> <a href="http://cypress.com/go/plc">cypress.com/go/plc</a>
Memory	<a href="http://cypress.com/go/memory">cypress.com/go/memory</a>
Optical & Image Sensing	<a href="http://cypress.com/go/image">cypress.com/go/image</a>
PSoC	<a href="http://cypress.com/go/psoc">cypress.com/go/psoc</a>
Touch Sensing	<a href="http://cypress.com/go/touch">cypress.com/go/touch</a>
USB Controllers	<a href="http://cypress.com/go/USB">cypress.com/go/USB</a>
Wireless/RF	<a href="http://cypress.com/go/wireless">cypress.com/go/wireless</a>

#### PSoC Solutions

[psoc.cypress.com/solutions](http://psoc.cypress.com/solutions)  
PSoC 1 | PSoC 3 | PSoC 5

---

© Cypress Semiconductor Corporation, 2009-2011. The information contained herein is subject to change without notice. Cypress Semiconductor Corporation assumes no responsibility for the use of any circuitry other than circuitry embodied in a Cypress product. Nor does it convey or imply any license under patent or other rights. Cypress products are not warranted nor intended to be used for medical, life support, life saving, critical control or safety applications, unless pursuant to an express written agreement with Cypress. Furthermore, Cypress does not authorize its products for use as critical components in life-support systems where a malfunction or failure may reasonably be expected to result in significant injury to the user. The inclusion of Cypress products in life-support systems application implies that the manufacturer assumes all risk of such use and in doing so indemnifies Cypress against all charges.

Any Source Code (software and/or firmware) is owned by Cypress Semiconductor Corporation (Cypress) and is protected by and subject to worldwide patent protection (United States and foreign), United States copyright laws and international treaty provisions. Cypress hereby grants to licensee a personal, non-exclusive, non-transferable license to copy, use, modify, create derivative works of, and compile the Cypress Source Code and derivative works for the sole purpose of creating custom software and or firmware in support of licensee product to be used only in conjunction with a Cypress integrated circuit as specified in the applicable agreement. Any reproduction, modification, translation, compilation, or representation of this Source Code except as specified above is prohibited without the express written permission of Cypress.

Disclaimer: CYPRESS MAKES NO WARRANTY OF ANY KIND, EXPRESS OR IMPLIED, WITH REGARD TO THIS MATERIAL, INCLUDING, BUT NOT LIMITED TO, THE IMPLIED WARRANTIES OF MERCHANTABILITY AND FITNESS FOR A PARTICULAR PURPOSE. Cypress reserves the right to make changes without further notice to the materials described herein. Cypress does not assume any liability arising out of the application or use of any product or circuit described herein. Cypress does not authorize its products for use as critical components in life-support systems where a malfunction or failure may reasonably be expected to result in significant injury to the user. The inclusion of Cypress' product in a life-support systems application implies that the manufacturer assumes all risk of such use and in doing so indemnifies Cypress against all charges.

Use may be limited by and subject to the applicable Cypress software license agreement.



Компания «Океан Электроники» предлагает заключение долгосрочных отношений при поставках импортных электронных компонентов на взаимовыгодных условиях!

Наши преимущества:

- Поставка оригинальных импортных электронных компонентов напрямую с производств Америки, Европы и Азии, а так же с крупнейших складов мира;
- Широкая линейка поставок активных и пассивных импортных электронных компонентов (более 30 млн. наименований);
- Поставка сложных, дефицитных, либо снятых с производства позиций;
- Оперативные сроки поставки под заказ (от 5 рабочих дней);
- Экспресс доставка в любую точку России;
- Помощь Конструкторского Отдела и консультации квалифицированных инженеров;
- Техническая поддержка проекта, помощь в подборе аналогов, поставка прототипов;
- Поставка электронных компонентов под контролем ВП;
- Система менеджмента качества сертифицирована по Международному стандарту ISO 9001;
- При необходимости вся продукция военного и аэрокосмического назначения проходит испытания и сертификацию в лаборатории (по согласованию с заказчиком);
- Поставка специализированных компонентов военного и аэрокосмического уровня качества (Xilinx, Altera, Analog Devices, Intersil, Interpoint, Microsemi, Actel, Aeroflex, Peregrine, VPT, Syfer, Eurofarad, Texas Instruments, MS Kennedy, Miteq, Cobham, E2V, MA-COM, Hittite, Mini-Circuits, General Dynamics и др.);

Компания «Океан Электроники» является официальным дистрибьютором и эксклюзивным представителем в России одного из крупнейших производителей разъемов военного и аэрокосмического назначения «JONHON», а так же официальным дистрибьютором и эксклюзивным представителем в России производителя высокотехнологичных и надежных решений для передачи СВЧ сигналов «FORSTAR».



## JONHON

«JONHON» (основан в 1970 г.)

Разъемы специального, военного и аэрокосмического назначения:

(Применяются в военной, авиационной, аэрокосмической, морской, железнодорожной, горно- и нефтедобывающей отраслях промышленности)

«FORSTAR» (основан в 1998 г.)

ВЧ соединители, коаксиальные кабели,  
кабельные сборки и микроволновые компоненты:

(Применяются в телекоммуникациях гражданского и специального назначения, в средствах связи, РЛС, а так же военной, авиационной и аэрокосмической отраслях промышленности).



Телефон: 8 (812) 309-75-97 (многоканальный)

Факс: 8 (812) 320-03-32

Электронная почта: [ocean@oceanchips.ru](mailto:ocean@oceanchips.ru)

Web: <http://oceanchips.ru/>

Адрес: 198099, г. Санкт-Петербург, ул. Калинина, д. 2, корп. 4, лит. А