



dsPIC33FJ06GS101/X02 and dsPIC33FJ16GSX02/X04

16-Bit Digital Signal Controllers (up to 16-Kbyte Flash and up to 2-Kbyte SRAM) with High-Speed PWM, ADC and Comparators

Operating Conditions

- 3.0V to 3.6V, -40°C to +150°C, DC to 20 MIPS
- 3.0V to 3.6V, -40°C to +125°C, DC to 40 MIPS
- 3.0V to 3.6V, -40°C to +85°C, DC to 50 MIPS

Core: 16-Bit dsPIC33F CPU

- Code-Efficient (C and Assembly) Architecture
- Two 40-Bit Wide Accumulators
- Single-Cycle (MAC/MPY) with Dual Data Fetch
- Single-Cycle Mixed-Sign MUL plus Hardware Divide
- 32-Bit Multiply Support

Clock Management

- $\pm 2.0\%$ Internal Oscillator
- Programmable PLLs and Oscillator Clock Sources
- Fail-Safe Clock Monitor (FSCM)
- Independent Watchdog Timer (WDT)
- Fast Wake-up and Start-up

Power Management

- Low-Power Management modes (Sleep, Idle, Doze)
- Integrated Power-on Reset and Brown-out Reset

High-Speed PWM

- Up to Four PWM Pairs with Independent Timing
- Dead Time for Rising and Falling Edges
- 1.04 ns PWM Resolution
- PWM Support for:
 - DC/DC, AC/DC, Inverters, PFC and Lighting
- Programmable Fault Inputs
- Flexible Trigger Configurations for ADC Conversions

Advanced Analog Features

- ADC module:
 - 10-bit resolution with up to 2 Successive Approximation Register (SAR) converters (4 Msps) and up to six Sample-and-Hold (S&H) circuits
 - Up to 12 input channels grouped into six conversion pairs, plus two voltage reference monitoring inputs
 - Dedicated result buffer for each analog channel
- Flexible and Independent ADC Trigger Sources

Advanced Analog Features (Continued)

- Up to Four High-Speed Comparators with Direct Connection to the PWM module:
 - Programmable references with 1024 voltage points

Timers/Output Compare/Input Capture

- Three General Purpose Timers:
 - Three 16-bit and one 32-bit timer/counter
- Two Output Compare (OC) modules
- Two Input Capture (IC) modules
- Peripheral Pin Select (PPS) to allow Function Remap

Communication Interfaces

- UART module (12.5 Mbps):
 - With support for LIN/J2602 protocols and IrDA[®]
- 4-Wire SPI module
- I²C[™] module (up to 1 Mbaud) with SMBus Support
- PPS to allow Function Remap

Input/Output

- Sink/Source 18 mA on 8 Pins, 10 mA on 10 Pins and 6 mA on 17 Pins
- 5V Tolerant Pins
- Selectable Open-Drain and Pull-ups
- External Interrupts on up to 30 I/O Pins

Qualification and Class B Support

- AEC-Q100 REVG (Grade 1, -40°C to +125°C)
- AEC-Q100 REVG (Grade 0, -40°C to +150°C)
- Class B Safety Library, IEC 60730, VDE Certified
- 6x6x0.5 mm UQFN Package Designed and Optimized to ease IPC9592A 2nd Level Temperature Cycle Qualification

Debugger Development Support

- In-Circuit and In-Application Programming
- Two Breakpoints
- IEEE 1149.2-Compatible (JTAG) Boundary Scan
- Trace and Run-Time Watch

dsPIC33FJ06GS101/X02 and dsPIC33FJ16GSX02/X04

dsPIC33FJ06GS101/X02 AND dsPIC33FJ16GSX02/X04 PRODUCT FAMILIES

The device names, pin counts, memory sizes and peripheral availability of each device are listed below. The following pages show their pinout diagrams.

TABLE 1: dsPIC33FJ06GS101/X02 and dsPIC33FJ16GSX02/X04 CONTROLLER FAMILIES

Device	Pins	Program Flash Memory (Kbytes)	RAM (Bytes)	Remappable Peripherals									DAC Output	I ² C™	ADC			I/O Pins	Packages
				Remappable Pins	16-Bit Timer	Input Capture	Output Compare	UART	SPI	PWM ⁽²⁾	Analog Comparator	External Interrupts ⁽³⁾			SARs	Sample-and-Hold (S&H) Circuit	Analog-to-Digital Inputs		
dsPIC33FJ06GS101	18	6	256	8	2	0	1	1	1	2x2 ⁽¹⁾	0	3	0	1	1	3	6	13	SOIC
dsPIC33FJ06GS102	28	6	256	16	2	0	1	1	1	2x2	0	3	0	1	1	3	6	21	SPDIP, SOIC, QFN-S
dsPIC33FJ06GS202	28	6	1K	16	2	1	1	1	1	2x2	2	3	1	1	1	3	6	21	SPDIP, SOIC, QFN-S
dsPIC33FJ16GS402	28	16	2K	16	3	2	2	1	1	3x2	0	3	0	1	1	4	8	21	SPDIP, SOIC, QFN-S
dsPIC33FJ16GS404	44	16	2K	30	3	2	2	1	1	3x2	0	3	0	1	1	4	8	35	QFN, TQFP, VTLA
dsPIC33FJ16GS502	28	16	2K	16	3	2	2	1	1	4x2 ⁽¹⁾	4	3	1	1	2	6	8	21	SPDIP, SOIC, QFN-S, UQFN
dsPIC33FJ16GS504	44	16	2K	30	3	2	2	1	1	4x2 ⁽¹⁾	4	3	1	1	2	6	12	35	QFN, TQFP, VTLA

- Note 1:** The PWM4H:PWM4L pins are remappable.
Note 2: The PWM Fault pins and PWM synchronization pins are remappable.
Note 3: Only two out of three interrupts are remappable.

dsPIC33FJ06GS101/X02 and dsPIC33FJ16GSX02/X04

Pin Diagrams

18-Pin SOIC

■ = Pins are up to 5V tolerant



28-Pin SOIC, SPDIP

■ = Pins are up to 5V tolerant



28-Pin SPDIP, SOIC

■ = Pins are up to 5V tolerant



Note 1: The RPN pins can be used by any remappable peripheral. See [Table 1](#) for the list of available peripherals.

dsPIC33FJ06GS101/X02 and dsPIC33FJ16GSX02/X04

Pin Diagrams (Continued)

28-Pin SPDIP, SOIC

■ = Pins are up to 5V tolerant



28-Pin SPDIP, SOIC

■ = Pins are up to 5V tolerant



Note 1: The RPN pins can be used by any remappable peripheral. See [Table 1](#) for the list of available peripherals.

dsPIC33FJ06GS101/X02 and dsPIC33FJ16GSX02/X04

Pin Diagrams (Continued)

28-Pin QFN-S⁽²⁾

■ = Pins are up to 5V tolerant



28-Pin QFN-S

■ = Pins are up to 5V tolerant

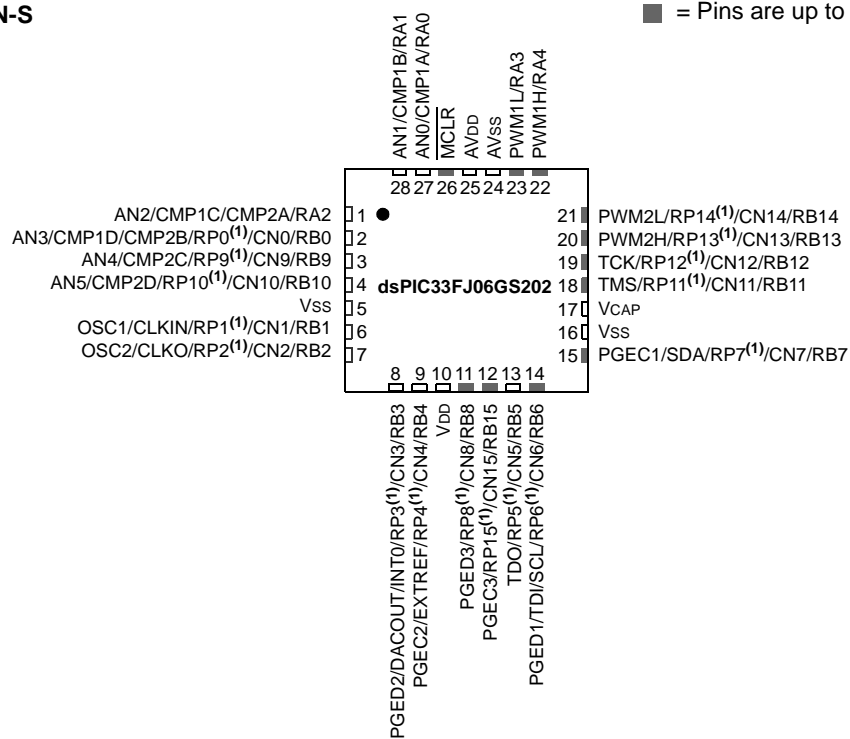

- Note** 1: The RPN pins can be used by any remappable peripheral. See [Table 1](#) for the list of available peripherals.
 2: The metal plane at the bottom of the device is not connected to any pins and is recommended to be connected to VSS externally.

dsPIC33FJ06GS101/X02 and dsPIC33FJ16GSX02/X04

Pin Diagrams (Continued)

28-Pin QFN-S⁽²⁾



28-Pin QFN-S, UQFN^(2,3)



- Note**
- 1: The RPN pins can be used by any remappable peripheral. See [Table 1](#) for the list of available peripherals.
 - 2: The metal plane at the bottom of the device is not connected to any pins and is recommended to be connected to Vss externally.
 - 3: This package is available only in Extended temperature and not Industrial temperature (applies to dsPIC33FJ16GS502 UQFN package only).

dsPIC33FJ06GS101/X02 and dsPIC33FJ16GSX02/X04

Pin Diagrams (Continued)



dsPIC33FJ06GS101/X02 and dsPIC33FJ16GSX02/X04

Pin Diagrams (Continued)

44-Pin VTLA⁽²⁾

■ = Pins are up to 5V tolerant

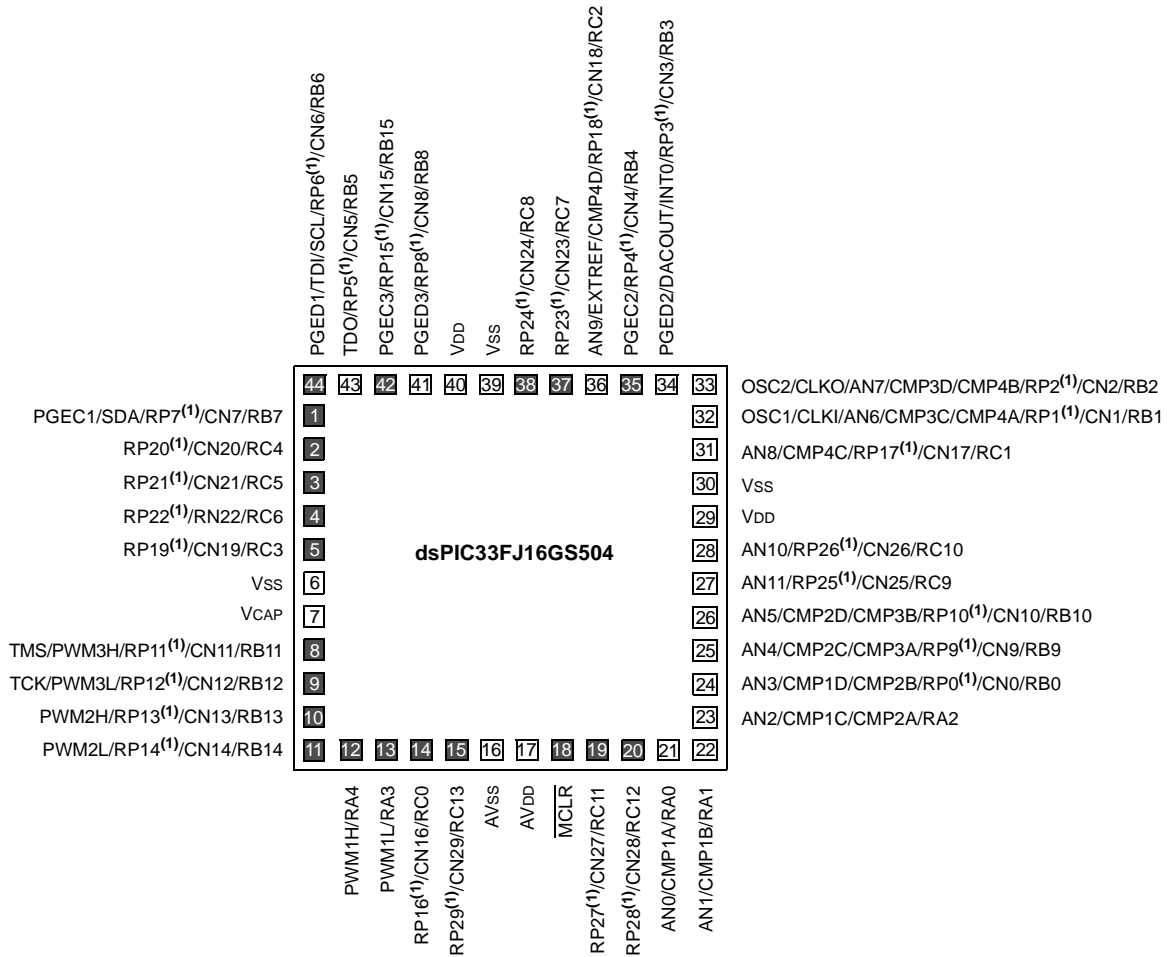

- Note** 1: The RPN pins can be used by any remappable peripheral. See [Table 1](#) for the list of available peripherals.
 2: The metal plane at the bottom of the device is not connected to any pins and is recommended to be connected to Vss externally.

dsPIC33FJ06GS101/X02 and dsPIC33FJ16GSX02/X04

Pin Diagrams (Continued)

44-Pin QFN⁽²⁾

■ = Pins are up to 5V tolerant



- Note** 1: The RPn pins can be used by any remappable peripheral. See [Table 1](#) for the list of available peripherals.
 2: The metal plane at the bottom of the device is not connected to any pins and is recommended to be connected to Vss externally.

dsPIC33FJ06GS101/X02 and dsPIC33FJ16GSX02/X04

Pin Diagrams (Continued)

44-Pin QFN⁽²⁾

■ = Pins are up to 5V tolerant



- Note 1:** The RPN pins can be used by any remappable peripheral. See [Table 1](#) for the list of available peripherals.
- Note 2:** The metal plane at the bottom of the device is not connected to any pins and is recommended to be connected to Vss externally.

dsPIC33FJ06GS101/X02 and dsPIC33FJ16GSX02/X04

Pin Diagrams (Continued)



dsPIC33FJ06GS101/X02 and dsPIC33FJ16GSX02/X04

Pin Diagrams (Continued)



dsPIC33FJ06GS101/X02 and dsPIC33FJ16GSX02/X04

Table of Contents

dsPIC33FJ06GS101/X02 AND dsPIC33FJ16GSX02/X04 Product Families.....	2
1.0 Device Overview	17
2.0 Guidelines for Getting Started with 16-bit Digital Signal Controllers	21
3.0 CPU.....	31
4.0 Memory Organization.....	43
5.0 Flash Program Memory.....	83
6.0 Resets	89
7.0 Interrupt Controller	97
8.0 Oscillator Configuration	135
9.0 Power-Saving Features.....	147
10.0 I/O Ports	155
11.0 Timer1	183
12.0 Timer2/3 Features	185
13.0 Input Capture.....	191
14.0 Output Compare.....	193
15.0 High-Speed PWM.....	197
16.0 Serial Peripheral Interface (SPI).....	219
17.0 Inter-Integrated Circuit (I ² C™)	225
18.0 Universal Asynchronous Receiver Transmitter (UART)	233
19.0 High-Speed 10-bit Analog-to-Digital Converter (ADC)	239
20.0 High-Speed Analog Comparator	263
21.0 Special Features	267
22.0 Instruction Set Summary	275
23.0 Development Support.....	283
24.0 Electrical Characteristics	287
25.0 High-Temperature Electrical Characteristics	333
26.0 50 MIPS Electrical Characteristics	341
27.0 DC and AC Device Characteristics Graphs.....	347
28.0 Packaging Information.....	351
The Microchip Web Site.....	393
Customer Change Notification Service	393
Customer Support.....	393
Product Identification System	395

dsPIC33FJ06GS101/X02 and dsPIC33FJ16GSX02/X04

TO OUR VALUED CUSTOMERS

It is our intention to provide our valued customers with the best documentation possible to ensure successful use of your Microchip products. To this end, we will continue to improve our publications to better suit your needs. Our publications will be refined and enhanced as new volumes and updates are introduced.

If you have any questions or comments regarding this publication, please contact the Marketing Communications Department via E-mail at docerrors@microchip.com. We welcome your feedback.

Most Current Data Sheet

To obtain the most up-to-date version of this data sheet, please register at our Worldwide Web site at:

<http://www.microchip.com>

You can determine the version of a data sheet by examining its literature number found on the bottom outside corner of any page. The last character of the literature number is the version number, (e.g., DS30000000A is version A of document DS30000000).

Errata

An errata sheet, describing minor operational differences from the data sheet and recommended workarounds, may exist for current devices. As device/documentation issues become known to us, we will publish an errata sheet. The errata will specify the revision of silicon and revision of document to which it applies.

To determine if an errata sheet exists for a particular device, please check with one of the following:

- Microchip's Worldwide Web site; <http://www.microchip.com>
- Your local Microchip sales office (see last page)

When contacting a sales office, please specify which device, revision of silicon and data sheet (include literature number) you are using.

Customer Notification System

Register on our web site at www.microchip.com to receive the most current information on all of our products.

Referenced Sources

This device data sheet is based on the following individual chapters of the *dsPIC33/PIC24 Family Reference Manual*. These documents should be considered as the primary reference for the operation of a particular module or device feature.

Note: To access the documents listed below, browse to the documentation section of the [dsPIC33FJ16GS504](#) product page of the Microchip web site (www.microchip.com).

In addition to parameters, features, and other documentation, the resulting page provides links to the related family reference manual sections.

- “**Introduction**” (DS70197)
- “**CPU**” (DS70204)
- “**Data Memory**” (DS70202)
- “**Program Memory**” (DS70203)
- “**Flash Programming**” (DS70191)
- “**Reset**” (DS70192)
- “**Watchdog Timer (WDT) and Power-Saving Modes**” (DS70196)
- “**I/O Ports**” (DS70193)
- “**Timers**” (DS70205)
- “**Input Capture**” (DS70198)
- “**Output Compare**” (DS70005157)
- “**Analog-to-Digital Converter (ADC)**” (DS70621)
- “**UART**” (DS70188)
- “**Serial Peripheral Interface (SPI)**” (DS70206)
- “**Inter-Integrated Circuit™ (I²C™)**” (DS70000195)
- “**CodeGuard™ Security**” (DS70199)
- “**Programming and Diagnostics**” (DS70207)
- “**Device Configuration**” (DS70194)
- “**Interrupts (Part IV)**” (DS70300)
- “**Oscillator (Part IV)**” (DS70307)
- “**High-Speed PWM Module**” (DS70000323)
- “**High-Speed 10-Bit ADC**” (DS70000321)
- “**High-Speed Analog Comparator**” (DS70296)
- “**Oscillator (Part VI)**” (DS70644)

dsPIC33FJ06GS101/X02 and dsPIC33FJ16GSX02/X04

NOTES:

dsPIC33FJ06GS101/X02 and dsPIC33FJ16GSX02/X04

1.0 DEVICE OVERVIEW

Note 1: This data sheet summarizes the features of the dsPIC33FJ06GS101/X02 and dsPIC33FJ16GSX02/X04 families of devices. It is not intended to be a comprehensive reference source. To complement the information in this data sheet, refer to the “*dsPIC33F/PIC24H Family Reference Manual*”. Please see the Microchip web site (www.microchip.com) for the latest “*dsPIC33F/PIC24H Family Reference Manual*” sections.

2: Some registers and associated bits described in this section may not be available on all devices. Refer to **Section 4.0 “Memory Organization”** in this data sheet for device-specific register and bit information.

This document contains device-specific information for the following dsPIC33F Digital Signal Controller (DSC) devices:

- dsPIC33FJ06GS101
- dsPIC33FJ06GS102
- dsPIC33FJ06GS202
- dsPIC33FJ16GS402
- dsPIC33FJ16GS404
- dsPIC33FJ16GS502
- dsPIC33FJ16GS504

dsPIC33FJ06GS101/X02 and dsPIC33FJ16GSX02/X04 devices contain extensive Digital Signal Processor (DSP) functionality with a high-performance, 16-bit microcontroller (MCU) architecture.

[Figure 1-1](#) shows a general block diagram of the core and peripheral modules in the dsPIC33FJ06GS101/X02 and dsPIC33FJ16GSX02/X04 devices. [Table 1-1](#) lists the functions of the various pins shown in the pinout diagrams.

dsPIC33FJ06GS101/X02 and dsPIC33FJ16GSX02/X04

FIGURE 1-1: dsPIC33FJ06GS101/X02 and dsPIC33FJ16GSX02/X04 BLOCK DIAGRAM



dsPIC33FJ06GS101/X02 and dsPIC33FJ16GSX02/X04

TABLE 1-1: PINOUT I/O DESCRIPTIONS

Pin Name	Pin Type	Buffer Type	PPS Capable	Description
AN0-AN11	I	Analog	No	Analog input channels
CLKI	I	ST/CMOS	No	External clock source input. Always associated with OSC1 pin function.
CLKO	O	—	No	Oscillator crystal output. Connects to crystal or resonator in Crystal Oscillator mode. Optionally functions as CLKO in RC and EC modes. Always associated with OSC2 pin function.
OSC1	I	ST/CMOS	No	Oscillator crystal input. ST buffer when configured in RC mode; CMOS otherwise.
OSC2	I/O	—	No	Oscillator crystal output. Connects to crystal or resonator in Crystal Oscillator mode. Optionally functions as CLKO in RC and EC modes.
CN0-CN29	I	ST	No	Change Notification inputs. Can be software programmed for internal weak pull-ups on all inputs.
IC1-IC2	I	ST	Yes	Capture Inputs 1/2.
OCFA	I	ST	Yes	Compare Fault A input (for Compare Channels 1 and 2)
OC1-OC2	O	—	Yes	Compare Outputs 1 through 2.
INT0	I	ST	No	External Interrupt 0.
INT1	I	ST	Yes	External Interrupt 1.
INT2	I	ST	Yes	External Interrupt 2.
RA0-RA4	I/O	ST	No	PORTA is a bidirectional I/O port.
RB0-RB15	I/O	ST	No	PORTB is a bidirectional I/O port.
RC0-RC13	I/O	ST	No	PORTC is a bidirectional I/O port.
RP0-RP29	I/O	ST	No	Remappable I/O pins.
T1CK	I	ST	Yes	Timer1 external clock input.
T2CK	I	ST	Yes	Timer2 external clock input.
T3CK	I	ST	Yes	Timer3 external clock input.
$\overline{U1CTS}$	I	ST	Yes	UART1 Clear-To-Send.
U1RTS	O	—	Yes	UART1 Ready-To-Send.
U1RX	I	ST	Yes	UART1 receive.
U1TX	O	—	Yes	UART1 transmit.
SCK1	I/O	ST	Yes	Synchronous serial clock input/output for SPI1.
SDI1	I	ST	Yes	SPI1 data in.
SDO1	O	—	Yes	SPI1 data out.
SS1	I/O	ST	Yes	SPI1 slave synchronization or frame pulse I/O.
SCL1	I/O	ST	No	Synchronous serial clock input/output for I2C1.
SDA1	I/O	ST	No	Synchronous serial data input/output for I2C1.
TMS	I	TTL	No	JTAG Test mode select pin.
TCK	I	TTL	No	JTAG test clock input pin.
TDI	I	TTL	No	JTAG test data input pin.
TDO	O	—	No	JTAG test data output pin.

Legend: CMOS = CMOS compatible input or output Analog = Analog input I = Input
 ST = Schmitt Trigger input with CMOS levels P = Power O = Output
 TTL = Transistor-Transistor Logic PPS = Peripheral Pin Select

dsPIC33FJ06GS101/X02 and dsPIC33FJ16GSX02/X04

TABLE 1-1: PINOUT I/O DESCRIPTIONS (CONTINUED)

Pin Name	Pin Type	Buffer Type	PPS Capable	Description
CMP1A	I	Analog	No	Comparator 1 Channel A.
CMP1B	I	Analog	No	Comparator 1 Channel B.
CMP1C	I	Analog	No	Comparator 1 Channel C.
CMP1D	I	Analog	No	Comparator 1 Channel D.
CMP2A	I	Analog	No	Comparator 2 Channel A.
CMP2B	I	Analog	No	Comparator 2 Channel B.
CMP2C	I	Analog	No	Comparator 2 Channel C.
CMP2D	I	Analog	No	Comparator 2 Channel D.
CMP3A	I	Analog	No	Comparator 3 Channel A.
CMP3B	I	Analog	No	Comparator 3 Channel B.
CMP3C	I	Analog	No	Comparator 3 Channel C.
CMP3D	I	Analog	No	Comparator 3 Channel D.
CMP4A	I	Analog	No	Comparator 4 Channel A.
CMP4B	I	Analog	No	Comparator 4 Channel B.
CMP4C	I	Analog	No	Comparator 4 Channel C.
CMP4D	I	Analog	No	Comparator 4 Channel D.
DACOUT	O	—	No	DAC output voltage.
ACMP1-ACMP4	O	—	Yes	DAC trigger to PWM module.
EXTREF	I	Analog	No	External voltage reference input for the reference DACs.
REFCLKO	O	—	Yes	REFCLKO output signal is a postscaled derivative of the system clock.
FLT1-FLT8	I	ST	Yes	Fault Inputs to PWM module.
SYNC11-SYNC12	I	ST	Yes	External synchronization signal to PWM master time base.
SYNCO1	O	—	Yes	PWM master time base for external device synchronization.
PWM1L	O	—	No	PWM1 low output.
PWM1H	O	—	No	PWM1 high output.
PWM2L	O	—	No	PWM2 low output.
PWM2H	O	—	No	PWM2 high output.
PWM3L	O	—	No	PWM3 low output.
PWM3H	O	—	No	PWM3 high output.
PWM4L	O	—	Yes	PWM4 low output.
PWM4H	O	—	Yes	PWM4 high output.
PGED1	I/O	ST	No	Data I/O pin for programming/debugging Communication Channel 1.
PGEC1	I	ST	No	Clock input pin for programming/debugging Communication Channel 1.
PGED2	I/O	ST	No	Data I/O pin for programming/debugging Communication Channel 2.
PGEC2	I	ST	No	Clock input pin for programming/debugging Communication Channel 2.
PGED3	I/O	ST	No	Data I/O pin for programming/debugging Communication Channel 3.
PGEC3	I	ST	No	Clock input pin for programming/debugging Communication Channel 3.
MCLR	I/P	ST	No	Master Clear (Reset) input. This pin is an active-low Reset to the device.
AVDD	P	P	No	Positive supply for analog modules. This pin must be connected at all times. AVDD is connected to VDD.
AVSS	P	P	No	Ground reference for analog modules. AVSS is connected to VSS.
VDD	P	—	No	Positive supply for peripheral logic and I/O pins.
VCAP	P	—	No	CPU logic filter capacitor connection.
VSS	P	—	No	Ground reference for logic and I/O pins.

Legend: CMOS = CMOS compatible input or output Analog = Analog input I = Input
 ST = Schmitt Trigger input with CMOS levels P = Power O = Output
 TTL = Transistor-Transistor Logic PPS = Peripheral Pin Select

2.0 GUIDELINES FOR GETTING STARTED WITH 16-BIT DIGITAL SIGNAL CONTROLLERS

Note 1: This data sheet summarizes the features of the dsPIC33FJ06GS101/X02 and dsPIC33FJ16GSX02/X04 family of devices. It is not intended to be a comprehensive reference source. To complement the information in this data sheet, refer to the “*dsPIC33F/PIC24H Family Reference Manual*”, which is available from the Microchip web site (www.microchip.com).

2: Some registers and associated bits described in this section may not be available on all devices. Refer to [Section 4.0 “Memory Organization”](#) in this data sheet for device-specific register and bit information.

2.1 Basic Connection Requirements

Getting started with the dsPIC33FJ06GS101/X02 and dsPIC33FJ16GSX02/X04 family of 16-bit Digital Signal Controllers (DSC) requires attention to a minimal set of device pin connections before proceeding with development. The following is a list of pin names, which must always be connected:

- All VDD and VSS pins (see [Section 2.2 “Decoupling Capacitors”](#))
- All AVDD and AVSS pins (regardless if ADC module is not used) (see [Section 2.2 “Decoupling Capacitors”](#))
- VCAP (see [Section 2.3 “Capacitor on Internal Voltage Regulator \(VCAP\)”](#))
- MCLR pin (see [Section 2.4 “Master Clear \(MCLR\) Pin”](#))
- PGECx/PGEDx pins used for In-Circuit Serial Programming™ (ICSP™) and debugging purposes (see [Section 2.5 “ICSP™ Pins”](#))
- OSC1 and OSC2 pins when external oscillator source is used (see [Section 2.6 “External Oscillator Pins”](#))

2.2 Decoupling Capacitors

The use of decoupling capacitors on every pair of power supply pins, such as VDD, VSS, AVDD and AVSS is required.

Consider the following criteria when using decoupling capacitors:

- **Value and type of capacitor:** Recommendation of 0.1 μF (100 nF), 10-20V. This capacitor should be a low-ESR and have resonance frequency in the range of 20 MHz and higher. It is recommended that ceramic capacitors be used.
- **Placement on the printed circuit board:** The decoupling capacitors should be placed as close to the pins as possible. It is recommended to place the capacitors on the same side of the board as the device. If space is constricted, the capacitor can be placed on another layer on the PCB using a via; however, ensure that the trace length from the pin to the capacitor is within one-quarter inch (6 mm) in length.
- **Handling high frequency noise:** If the board is experiencing high frequency noise, upward of tens of MHz, add a second ceramic-type capacitor in parallel to the above described decoupling capacitor. The value of the second capacitor can be in the range of 0.01 μF to 0.001 μF . Place this second capacitor next to the primary decoupling capacitor. In high-speed circuit designs, consider implementing a decade pair of capacitances as close to the power and ground pins as possible. For example, 0.1 μF in parallel with 0.001 μF .
- **Maximizing performance:** On the board layout from the power supply circuit, run the power and return traces to the decoupling capacitors first, and then to the device pins. This ensures that the decoupling capacitors are first in the power chain. Equally important is to keep the trace length between the capacitor and the power pins to a minimum thereby reducing PCB track inductance.

dsPIC33FJ06GS101/X02 and dsPIC33FJ16GSX02/X04

FIGURE 2-1: RECOMMENDED MINIMUM CONNECTION



2.2.1 TANK CAPACITORS

On boards with power traces running longer than six inches in length, it is suggested to use a tank capacitor for integrated circuits including DSCs to supply a local power source. The value of the tank capacitor should be determined based on the trace resistance that connects the power supply source to the device, and the maximum current drawn by the device in the application. In other words, select the tank capacitor so that it meets the acceptable voltage sag at the device. Typical values range from 4.7 µF to 47 µF.

2.3 Capacitor on Internal Voltage Regulator (VCAP)

A low-ESR (<5 Ohms) capacitor is required on the VCAP pin, which is used to stabilize the voltage regulator output voltage. The VCAP pin must not be connected to VDD, and must have a capacitor between 4.7 µF and 10 µF, 16V connected to ground. The type can be ceramic or tantalum. Refer to [Section 24.0 "Electrical Characteristics"](#) for additional information.

The placement of this capacitor should be close to the VCAP. It is recommended that the trace length not exceed one-quarter inch (6 mm). Refer to [Section 21.2 "On-Chip Voltage Regulator"](#) for details.

2.4 Master Clear (MCLR) Pin

The MCLR pin provides two specific device functions:

- Device Reset
- Device programming and debugging.

During device programming and debugging, the resistance and capacitance that can be added to the pin must be considered. Device programmers and debuggers drive the MCLR pin. Consequently, specific voltage levels (VIH and VIL) and fast signal transitions must not be adversely affected. Therefore, specific values of R and C will need to be adjusted based on the application and PCB requirements.

For example, as shown in [Figure 2-2](#), it is recommended that the capacitor C, be isolated from the MCLR pin during programming and debugging operations.

Place the components shown in [Figure 2-2](#) within one-quarter inch (6 mm) from the MCLR pin.

FIGURE 2-2: EXAMPLE OF MCLR PIN CONNECTIONS



2.5 ICSP™ Pins

The PGECx and PGEDx pins are used for In-Circuit Serial Programming™ (ICSP™) and debugging purposes. It is recommended to keep the trace length between the ICSP connector and the ICSP pins on the device as short as possible. If the ICSP connector is expected to experience an ESD event, a series resistor is recommended, with the value in the range of a few tens of Ohms, not to exceed 100 Ohms.

Pull-up resistors, series diodes, and capacitors on the PGECx and PGEDx pins are not recommended as they will interfere with the programmer/debugger communications to the device. If such discrete components are an application requirement, they should be removed from the circuit during programming and debugging. Alternatively, refer to the AC/DC characteristics and timing requirements information in the respective device Flash programming specification for information on capacitive loading limits and pin input voltage high (V_{IH}) and input low (V_{IL}) requirements.

Ensure that the “Communication Channel Select” (i.e., PGECx/PGEDx pins) programmed into the device matches the physical connections for the ICSP to MPLAB® ICD 3 or MPLAB® REAL ICE™.

For more information on ICD 3 and REAL ICE connection requirements, refer to the following documents that are available on the Microchip web site.

- “Using MPLAB® ICD 3” (poster) DS51765
- “MPLAB® ICD 3 Design Advisory” DS51764
- “MPLAB® REAL ICE™ In-Circuit Debugger User’s Guide” DS51616
- “Using MPLAB® REAL ICE™” (poster) DS51749

2.6 External Oscillator Pins

Many DSCs have options for at least two oscillators: a high-frequency primary oscillator and a low-frequency secondary oscillator (refer to [Section 8.0 “Oscillator Configuration”](#) for details).

The oscillator circuit should be placed on the same side of the board as the device. Also, place the oscillator circuit close to the respective oscillator pins, not exceeding one-half inch (12 mm) distance between them. The load capacitors should be placed next to the oscillator itself, on the same side of the board. Use a grounded copper pour around the oscillator circuit to isolate them from surrounding circuits. The grounded copper pour should be routed directly to the MCU ground. Do not run any signal traces or power traces inside the ground pour. Also, if using a two-sided board, avoid any traces on the other side of the board where the crystal is placed. A suggested layout is shown in [Figure 2-3](#).

FIGURE 2-3: SUGGESTED PLACEMENT OF THE OSCILLATOR CIRCUIT



2.7 Oscillator Value Conditions on Device Start-up

If the PLL of the target device is enabled and configured for the device start-up oscillator, the maximum oscillator source frequency must be limited to $4 \text{ MHz} < F_{IN} < 8 \text{ MHz}$ to comply with device PLL start-up conditions. This means that if the external oscillator frequency is outside this range, the application must start up in the FRC mode first. The default PLL settings after a POR with an oscillator frequency outside this range will violate the device operating speed.

Once the device powers up, the application firmware can initialize the PLL SFRs, CLKDIV, and PLLFBD to a suitable value, and then perform a clock switch to the Oscillator + PLL clock source. Note that clock switching must be enabled in the device Configuration Word.

2.8 Configuration of Analog and Digital Pins During ICSP Operations

If MPLAB ICD 2, ICD 3 or REAL ICE is selected as a debugger, it automatically initializes all of the A/D input pins (ANx) as “digital” pins, by setting all bits in the ADPCFG register.

The bits in the registers that correspond to the A/D pins that are initialized by MPLAB ICD 2, ICD 3, or REAL ICE, must not be cleared by the user application firmware; otherwise, communication errors will result between the debugger and the device.

If your application needs to use certain A/D pins as analog input pins during the debug session, the user application must clear the corresponding bits in the ADPCFG register during initialization of the ADC module.

When MPLAB ICD 2, ICD 3, or REAL ICE is used as a programmer, the user application firmware must correctly configure the ADPCFG register. Automatic initialization of these registers is only done during debugger operation. Failure to correctly configure the register(s) will result in all A/D pins being recognized as analog input pins, resulting in the port value being read as a logic ‘0’, which may affect user application functionality.

2.9 Unused I/Os

Unused I/O pins should be configured as outputs and driven to a logic-low state.

Alternatively, connect a 1k to 10k resistor between Vss and unused pins and drive the output to logic low.

2.10 Typical Application Connection Examples

Examples of typical application connections are shown in [Figure 2-4](#) through [Figure 2-11](#).

dsPIC33FJ06GS101/X02 and dsPIC33FJ16GSX02/X04

FIGURE 2-4: DIGITAL PFC



FIGURE 2-5: BOOST CONVERTER IMPLEMENTATION



dsPIC33FJ06GS101/X02 and dsPIC33FJ16GSX02/X04

FIGURE 2-6: SINGLE-PHASE SYNCHRONOUS BUCK CONVERTER



FIGURE 2-7: MULTI-PHASE SYNCHRONOUS BUCK CONVERTER



dsPIC33FJ06GS101/X02 and dsPIC33FJ16GSX02/X04

FIGURE 2-8: OFF-LINE UPS



dsPIC33FJ06GS101/X02 and dsPIC33FJ16GSX02/X04

FIGURE 2-9: INTERLEAVED PFC



dsPIC33FJ06GS101/X02 and dsPIC33FJ16GSX02/X04

FIGURE 2-10: PHASE-SHIFTED FULL-BRIDGE CONVERTER



FIGURE 2-11: AC-TO-DC POWER SUPPLY WITH PFC AND THREE OUTPUTS (12V, 5V AND 3.3V)



3.0 CPU

Note 1: This data sheet summarizes the features of the dsPIC33FJ06GS101/X02 and dsPIC33FJ16GSX02/X04 families of devices. It is not intended to be a comprehensive reference source. To complement the information in this data sheet, refer to “CPU” (DS70204) in the “dsPIC33F/PIC24H Family Reference Manual”, which is available from the Microchip web site (www.microchip.com).

2: Some registers and associated bits described in this section may not be available on all devices. Refer to [Section 4.0 “Memory Organization”](#) in this data sheet for device-specific register and bit information.

The CPU module has a 16-bit (data) modified Harvard architecture with an enhanced instruction set, including significant support for DSP. The CPU has a 24-bit instruction word with a variable length opcode field. The Program Counter (PC) is 23 bits wide and addresses up to 4M x 24 bits of user program memory space. The actual amount of program memory implemented varies from device to device. A single-cycle instruction prefetch mechanism is used to help maintain throughput and provides predictable execution. All instructions execute in a single cycle, with the exception of instructions that change the program flow, the double-word move (MOV.D) instruction and the table instructions. Overhead-free program loop constructs are supported using the DO and REPEAT instructions, both of which are interruptible at any point.

dsPIC33FJ06GS101/X02 and dsPIC33FJ16GSX02/X04 devices have sixteen, 16-bit Working registers in the programmer’s model. Each of the Working registers can serve as a data, address or address offset register. The sixteenth Working register (W15) operates as a software Stack Pointer (SP) for interrupts and calls.

There are two classes of instruction in the dsPIC33FJ06GS101/X02 and dsPIC33FJ16GSX02/X04 devices: MCU and DSP. These two instruction classes are seamlessly integrated into a single CPU. The instruction set includes many addressing modes and is designed for optimum C compiler efficiency. For most instructions, the dsPIC33FJ06GS101/X02 and dsPIC33FJ16GSX02/X04 is capable of executing a data (or program data) memory read, a Working register (data) read, a data memory write and a program (instruction) memory read per instruction cycle. As a result, three parameter instructions can be supported, allowing $A + B = C$ operations to be executed in a single cycle.

A block diagram of the CPU is shown in [Figure 3-1](#), and the programmer’s model is shown in [Figure 3-2](#).

3.1 Data Addressing Overview

The data space can be addressed as 32K words or 64 Kbytes and is split into two blocks, referred to as X and Y data memory. Each memory block has its own independent Address Generation Unit (AGU). The MCU class of instructions operates solely through the X memory AGU, which accesses the entire memory map as one linear data space. Certain DSP instructions operate through the X and Y AGUs to support dual operand reads, which splits the data address space into two parts. The X and Y data space boundary is device-specific.

Overhead-free circular buffers (Modulo Addressing mode) are supported in both X and Y address spaces. The Modulo Addressing removes the software boundary checking overhead for DSP algorithms. Furthermore, the X AGU circular addressing can be used with any of the MCU class of instructions. The X AGU also supports Bit-Reversed Addressing to greatly simplify input or output data reordering for radix-2 FFT algorithms.

The upper 32 Kbytes of the data space memory map can optionally be mapped into program space at any 16K program word boundary defined by the 8-bit Program Space Visibility Page (PSVPAG) register. The program-to-data space mapping feature allows any instruction access program space as if it were data space.

3.2 DSP Engine Overview

The DSP engine features a high-speed, 17-bit by 17-bit multiplier, a 40-bit ALU, two 40-bit saturating accumulators and a 40-bit bidirectional barrel shifter. The barrel shifter is capable of shifting a 40-bit value up to 16 bits, right or left, in a single cycle. The DSP instructions operate seamlessly with all other instructions and have been designed for optimal real-time performance. The MAC instruction and other associated instructions can concurrently fetch two data operands from memory while multiplying two W registers and accumulating and optionally saturating the result in the same cycle. This instruction functionality requires that the RAM data space be split for these instructions and linear for all others. Data space partitioning is achieved in a transparent and flexible manner through dedicating certain Working registers to each address space.

dsPIC33FJ06GS101/X02 and dsPIC33FJ16GSX02/X04

3.3 Special MCU Features

dsPIC33FJ06GS101/X02 and dsPIC33FJ16GSX02/X04 devices feature a 17-bit by 17-bit single-cycle multiplier that is shared by both the MCU ALU and DSP engine. The multiplier can perform signed, unsigned and mixed sign multiplication. Using a 17-bit by 17-bit multiplier for 16-bit by 16-bit multiplication not only allows you to perform mixed sign multiplication, it also achieves accurate results for special operations, such as $(-1.0) \times (1.0)$.

The dsPIC33FJ06GS101/X02 and dsPIC33FJ16GSX02/X04 devices support 16/16 and 32/16 divide operations, both fractional and integer. All divide instructions are iterative operations. They must be executed within a REPEAT loop, resulting in a total execution time of 19 instruction cycles. The divide operation can be interrupted during any of those 19 cycles without loss of data.

A 40-bit barrel shifter is used to perform up to a 16-bit left or right shift in a single cycle. The barrel shifter can be used by both MCU and DSP instructions.

FIGURE 3-1: dsPIC33FJ06GS101/X02 and dsPIC33FJ16GSX02/X04 CPU CORE BLOCK DIAGRAM



dsPIC33FJ06GS101/X02 and dsPIC33FJ16GSX02/X04

FIGURE 3-2: dsPIC33FJ06GS101/X02 and dsPIC33FJ16GSX02/X04 PROGRAMMER'S MODEL



dsPIC33FJ06GS101/X02 and dsPIC33FJ16GSX02/X04

3.4 CPU Control Registers

REGISTER 3-1: SR: CPU STATUS REGISTER

R-0	R-0	R/C-0	R/C-0	R-0	R/C-0	R-0	R/W-0
OA	OB	SA ⁽¹⁾	SB ⁽¹⁾	OAB	SAB ^(1,4)	DA	DC
bit 15							bit 8

R/W-0 ⁽³⁾	R/W-0 ⁽³⁾	R/W-0 ⁽³⁾	R-0	R/W-0	R/W-0	R/W-0	R/W-0
IPL2 ⁽²⁾	IPL1 ⁽²⁾	IPL0 ⁽²⁾	RA	N	OV	Z	C
bit 7							bit 0

Legend:	C = Clearable bit		
R = Readable bit	W = Writable bit	-n = Value at POR	'1' = Bit is set
0' = Bit is cleared	'x' = Bit is unknown	U = Unimplemented bit, read as '0'	

- bit 15 **OA:** Accumulator A Overflow Status bit
1 = Accumulator A has overflowed
0 = Accumulator A has not overflowed
- bit 14 **OB:** Accumulator B Overflow Status bit
1 = Accumulator B has overflowed
0 = Accumulator B has not overflowed
- bit 13 **SA:** Accumulator A Saturation 'Sticky' Status bit⁽¹⁾
1 = Accumulator A is saturated or has been saturated at some time
0 = Accumulator A is not saturated
- bit 12 **SB:** Accumulator B Saturation 'Sticky' Status bit⁽¹⁾
1 = Accumulator B is saturated or has been saturated at some time
0 = Accumulator B is not saturated
- bit 11 **OAB:** OA || OB Combined Accumulator Overflow Status bit
1 = Accumulator A or B has overflowed
0 = Neither Accumulator A or B has overflowed
- bit 10 **SAB:** SA || SB Combined Accumulator 'Sticky' Status bit^(1,4)
1 = Accumulator A or B is saturated or has been saturated at some time in the past
0 = Neither Accumulator A or B is saturated
- bit 9 **DA:** DO Loop Active bit
1 = DO loop in progress
0 = DO loop not in progress
- bit 8 **DC:** MCU ALU Half Carry/Borrow bit
1 = A carry-out from the 4th low-order bit (for byte-sized data) or 8th low-order bit (for word-sized data) of the result occurred
0 = No carry-out from the 4th low-order bit (for byte-sized data) or 8th low-order bit (for word-sized data) of the result occurred

- Note 1:** This bit can be read or cleared (not set).
- Note 2:** The IPL<2:0> bits are concatenated with the IPL<3> bit (CORCON<3>) to form the CPU Interrupt Priority Level (IPL). The value in parentheses indicates the IPL if IPL<3> = 1. User interrupts are disabled when IPL<3> = 1.
- Note 3:** The IPL<2:0> Status bits are read-only when NSTDIS = 1 (INTCON1<15>).
- Note 4:** Clearing this bit will clear SA and SB.

dsPIC33FJ06GS101/X02 and dsPIC33FJ16GSX02/X04

REGISTER 3-1: SR: CPU STATUS REGISTER (CONTINUED)

bit 7-5	IPL<2:0> : CPU Interrupt Priority Level Status bits ^(2,3) 111 = CPU Interrupt Priority Level is 7 (15), user interrupts disabled 110 = CPU Interrupt Priority Level is 6 (14) 101 = CPU Interrupt Priority Level is 5 (13) 100 = CPU Interrupt Priority Level is 4 (12) 011 = CPU Interrupt Priority Level is 3 (11) 010 = CPU Interrupt Priority Level is 2 (10) 001 = CPU Interrupt Priority Level is 1 (9) 000 = CPU Interrupt Priority Level is 0 (8)
bit 4	RA : REPEAT Loop Active bit 1 = REPEAT loop in progress 0 = REPEAT loop not in progress
bit 3	N : MCU ALU Negative bit 1 = Result was negative 0 = Result was non-negative (zero or positive)
bit 2	OV : MCU ALU Overflow bit This bit is used for signed arithmetic (2's complement). It indicates an overflow of a magnitude that causes the sign bit to change state. 1 = Overflow occurred for signed arithmetic (in this arithmetic operation) 0 = No overflow occurred
bit 1	Z : MCU ALU Zero bit 1 = An operation that affects the Z bit has set it at some time in the past 0 = The most recent operation that affects the Z bit has cleared it (i.e., a non-zero result)
bit 0	C : MCU ALU Carry/ $\overline{\text{Borrow}}$ bit 1 = A carry-out from the Most Significant bit (MSb) of the result occurred 0 = No carry-out from the Most Significant bit of the result occurred

- Note 1:** This bit can be read or cleared (not set).
- 2:** The IPL<2:0> bits are concatenated with the IPL<3> bit (CORCON<3>) to form the CPU Interrupt Priority Level (IPL). The value in parentheses indicates the IPL if IPL<3> = 1. User interrupts are disabled when IPL<3> = 1.
- 3:** The IPL<2:0> Status bits are read-only when NSTDIS = 1 (INTCON1<15>).
- 4:** Clearing this bit will clear SA and SB.

dsPIC33FJ06GS101/X02 and dsPIC33FJ16GSX02/X04

REGISTER 3-2: CORCON: CORE CONTROL REGISTER

U-0	U-0	U-0	R/W-0	R/W-0	R-0	R-0	R-0
—	—	—	US	EDT ⁽¹⁾	DL2	DL1	DL0
bit 15						bit 8	

R/W-0	R/W-0	R/W-1	R/W-0	R/C-0	R/W-0	R/W-0	R/W-0
SATA	SATB	SATDW	ACCSAT	IPL3 ⁽²⁾	PSV	RND	IF
bit 7						bit 0	

Legend:	C = Clearable bit		
R = Readable bit	W = Writable bit	-n = Value at POR	'1' = Bit is set
0' = Bit is cleared	'x' = Bit is unknown	U = Unimplemented bit, read as '0'	

- bit 15-13 **Unimplemented:** Read as '0'
- bit 12 **US:** DSP Multiply Unsigned/Signed Control bit
1 = DSP engine multiplies are unsigned
0 = DSP engine multiplies are signed
- bit 11 **EDT:** Early DO Loop Termination Control bit⁽¹⁾
1 = Terminate executing DO loop at end of current loop iteration
0 = No effect
- bit 10-8 **DL<2:0>:** DO Loop Nesting Level Status bits
111 = 7 DO loops are active
•
•
•
001 = 1 DO loop is active
000 = 0 DO loops are active
- bit 7 **SATA:** ACCA Saturation Enable bit
1 = Accumulator A saturation is enabled
0 = Accumulator A saturation is disabled
- bit 6 **SATB:** ACCB Saturation Enable bit
1 = Accumulator B saturation is enabled
0 = Accumulator B saturation is disabled
- bit 5 **SATDW:** Data Space Write from DSP Engine Saturation Enable bit
1 = Data space write saturation is enabled
0 = Data space write saturation is disabled
- bit 4 **ACCSAT:** Accumulator Saturation Mode Select bit
1 = 9.31 saturation (super saturation)
0 = 1.31 saturation (normal saturation)
- bit 3 **IPL3:** CPU Interrupt Priority Level Status bit 3⁽²⁾
1 = CPU Interrupt Priority Level is greater than 7
0 = CPU Interrupt Priority Level is 7 or less
- bit 2 **PSV:** Program Space Visibility in Data Space Enable bit
1 = Program space is visible in data space
0 = Program space is not visible in data space

Note 1: This bit will always read as '0'.
Note 2: The IPL3 bit is concatenated with the IPL<2:0> bits (SR<7:5>) to form the CPU Interrupt Priority Level.

dsPIC33FJ06GS101/X02 and dsPIC33FJ16GSX02/X04

REGISTER 3-2: CORCON: CORE CONTROL REGISTER (CONTINUED)

- bit 1 **RND:** Rounding Mode Select bit
 1 = Biased (conventional) rounding is enabled
 0 = Unbiased (convergent) rounding is enabled
- bit 0 **IF:** Integer or Fractional Multiplier Mode Select bit
 1 = Integer mode is enabled for DSP multiply ops
 0 = Fractional mode is enabled for DSP multiply ops

Note 1: This bit will always read as '0'.

2: The IPL3 bit is concatenated with the IPL<2:0> bits (SR<7:5>) to form the CPU Interrupt Priority Level.

dsPIC33FJ06GS101/X02 and dsPIC33FJ16GSX02/X04

3.5 Arithmetic Logic Unit (ALU)

The dsPIC33FJ06GS101/X02 and dsPIC33FJ16GSX02/X04 ALU is 16 bits wide and is capable of addition, subtraction, bit shifts and logic operations. Unless otherwise mentioned, arithmetic operations are 2's complement in nature. Depending on the operation, the ALU can affect the values of the Carry (C), Zero (Z), Negative (N), Overflow (OV) and Digit Carry (DC) Status bits in the SR register. The C and DC Status bits operate as Borrow and Digit Borrow bits, respectively, for subtraction operations.

The ALU can perform 8-bit or 16-bit operations, depending on the mode of the instruction that is used. Data for the ALU operation can come from the W register array or data memory, depending on the addressing mode of the instruction. Likewise, output data from the ALU can be written to the W register array or a data memory location.

Refer to the “16-bit MCU and DSC Programmer's Reference Manual” (DS70157) for information on the SR bits affected by each instruction.

The dsPIC33FJ06GS101/X02 and dsPIC33FJ16GSX02/X04 CPU incorporates hardware support for both multiplication and division. This includes a dedicated hardware multiplier and support hardware for 16-bit-divisor division.

3.5.1 MULTIPLIER

Using the high-speed, 17-bit x 17-bit multiplier of the DSP engine, the ALU supports unsigned, signed or mixed sign operation in several MCU multiplication modes:

- 16-bit x 16-bit signed
- 16-bit x 16-bit unsigned
- 16-bit signed x 5-bit (literal) unsigned
- 16-bit unsigned x 16-bit unsigned
- 16-bit unsigned x 5-bit (literal) unsigned
- 16-bit unsigned x 16-bit signed
- 8-bit unsigned x 8-bit unsigned

3.5.2 DIVIDER

The divide block supports 32-bit/16-bit and 16-bit/16-bit signed and unsigned integer divide operations with the following data sizes:

- 32-bit signed/16-bit signed divide
- 32-bit unsigned/16-bit unsigned divide
- 16-bit signed/16-bit signed divide
- 16-bit unsigned/16-bit unsigned divide

The quotient for all divide instructions ends up in W0 and the remainder in W1. The 16-bit signed and unsigned DIV instructions can specify any W register for both the 16-bit divisor (Wn) and any W register (aligned) pair (W(m + 1):Wm) for the 32-bit dividend. The divide algorithm takes one cycle per bit of divisor, so both 32-bit/16-bit and 16-bit/16-bit instructions take the same number of cycles to execute.

3.6 DSP Engine

The DSP engine consists of a high-speed, 17-bit x 17-bit multiplier, a barrel shifter and a 40-bit adder/subtractor (with two target accumulators, round and saturation logic).

The dsPIC33FJ06GS101/X02 and dsPIC33FJ16GSX02/X04 is a single-cycle instruction flow architecture; therefore, concurrent operation of the DSP engine with MCU instruction flow is not possible. However, some MCU ALU and DSP engine resources can be used concurrently by the same instruction (for example, ED, EDAC).

The DSP engine can also perform inherent accumulator-to-accumulator operations that require no additional data. These instructions are ADD, SUB and NEG.

The DSP engine has options selected through bits in the CPU Core Control register (CORCON), as listed below:

- Fractional or Integer DSP Multiply (IF)
- Signed or Unsigned DSP Multiply (US)
- Conventional or Convergent Rounding (RND)
- Automatic Saturation On/Off for ACCA (SATA)
- Automatic Saturation On/Off for ACCB (SATB)
- Automatic Saturation On/Off for Writes to Data Memory (SATDW)
- Accumulator Saturation mode Selection (ACCSAT)

A block diagram of the DSP engine is shown in [Figure 3-3](#).

TABLE 3-1: DSP INSTRUCTIONS SUMMARY

Instruction	Algebraic Operation	ACC Write Back
CLR	$A = 0$	Yes
ED	$A = (x - y)^2$	No
EDAC	$A = A + (x - y)^2$	No
MAC	$A = A + (x * y)$	Yes
MAC	$A = A + x^2$	No
MOVSAC	No change in A	Yes
MPY	$A = x * y$	No
MPY	$A = x^2$	No
MPY.N	$A = -x * y$	No
MSC	$A = A - x * y$	Yes

dsPIC33FJ06GS101/X02 and dsPIC33FJ16GSX02/X04

FIGURE 3-3: DSP ENGINE BLOCK DIAGRAM



dsPIC33FJ06GS101/X02 and dsPIC33FJ16GSX02/X04

3.6.1 MULTIPLIER

The 17-bit x 17-bit multiplier is capable of signed or unsigned operation and can multiplex its output using a scaler to support either 1.31 fractional (Q31) or 32-bit integer results. Unsigned operands are zero-extended into the 17th bit of the multiplier input value. Signed operands are sign-extended into the 17th bit of the multiplier input value. The output of the 17-bit x 17-bit multiplier/scaler is a 33-bit value that is sign-extended to 40 bits. Integer data is inherently represented as a signed 2's complement value, where the Most Significant bit (MSb) is defined as a sign bit. The range of an N-bit 2's complement integer is -2^{N-1} to $2^{N-1} - 1$.

- For a 16-bit integer, the data range is -32768 (0x8000) to 32767 (0x7FFF), including 0.
- For a 32-bit integer, the data range is -2,147,483,648 (0x8000 0000) to 2,147,483,647 (0x7FFF FFFF).

When the multiplier is configured for fractional multiplication, the data is represented as a 2's complement fraction, where the MSb is defined as a sign bit and the radix point is implied to lie just after the sign bit (QX format). The range of an N-bit 2's complement fraction with this implied radix point is -1.0 to $(1 - 2^{1-N})$. For a 16-bit fraction, the Q15 data range is -1.0 (0x8000) to 0.999969482 (0x7FFF) including 0 and has a precision of 3.01518×10^{-5} . In Fractional mode, the 16 x 16 multiply operation generates a 1.31 product that has a precision of 4.65661×10^{-10} .

The same multiplier is used to support the MCU multiply instructions, which include integer 16-bit signed, unsigned and mixed sign multiply operations.

The MUL instruction can be directed to use byte or word-sized operands. Byte operands will direct a 16-bit result, and word operands will direct a 32-bit result to the specified register(s) in the W array.

3.6.2 DATA ACCUMULATORS AND ADDER/SUBTRACTER

The data accumulator consists of a 40-bit adder/subtracter with automatic sign extension logic. It can select one of two accumulators (A or B) as its pre-accumulation source and post-accumulation destination. For the ADD and LAC instructions, the data to be accumulated or loaded can be optionally scaled using the barrel shifter prior to accumulation.

3.6.2.1 Adder/Subtracter, Overflow and Saturation

The adder/subtracter is a 40-bit adder with an optional zero input into one side, and either true or complement data into the other input.

- In the case of addition, the Carry/Borrow input is active-high and the other input is true data (not complemented).
- In the case of subtraction, the Carry/Borrow input is active-low and the other input is complemented.

The adder/subtracter generates Overflow Status bits, SA/SB and OA/OB, which are latched and reflected in the STATUS Register:

- Overflow from bit 39: this is a catastrophic overflow in which the sign of the accumulator is destroyed.
- Overflow into guard bits, 32 through 39: this is a recoverable overflow. This bit is set whenever all the guard bits are not identical to each other.

The adder has an additional saturation block that controls accumulator data saturation, if selected. It uses the result of the adder, the Overflow Status bits described previously and the SAT<A:B> (CORCON<7:6>) and ACCSAT (CORCON<4>) mode control bits to determine when and to what value to saturate.

Six STATUS Register bits support saturation and overflow:

- OA: ACCA overflowed into guard bits
- OB: ACCB overflowed into guard bits
- SA: ACCA saturated (bit 31 overflow and saturation)
or
ACCA overflowed into guard bits and saturated (bit 39 overflow and saturation)
- SB: ACCB saturated (bit 31 overflow and saturation)
or
ACCB overflowed into guard bits and saturated (bit 39 overflow and saturation)
- OAB: Logical OR of OA and OB
- SAB: Logical OR of SA and SB

The OA and OB bits are modified each time data passes through the adder/subtracter. When set, they indicate that the most recent operation has overflowed into the accumulator guard bits (bits 32 through 39). The OA and OB bits can also optionally generate an arithmetic warning trap when set and the corresponding Overflow Trap Flag Enable bits (OVATE, OVBTE) in the INTCON1 register are set (refer to [Section 7.0 "Interrupt Controller"](#)). This allows the user application to take immediate action, for example, to correct system gain.

dsPIC33FJ06GS101/X02 and dsPIC33FJ16GSX02/X04

The SA and SB bits are modified each time data passes through the adder/subtractor, but can only be cleared by the user application. When set, they indicate that the accumulator has overflowed its maximum range (bit 31 for 32-bit saturation or bit 39 for 40-bit saturation) and will be saturated (if saturation is enabled). When saturation is not enabled, SA and SB default to bit 39 overflow and thus, indicate that a catastrophic overflow has occurred. If the COVTE bit in the INTCON1 register is set, SA and SB bits will generate an arithmetic warning trap when saturation is disabled.

The Overflow and Saturation Status bits can optionally be viewed in the STATUS Register (SR) as the logical OR of OA and OB (in bit OAB) and the logical OR of SA and SB (in bit SAB). Programmers can check one bit in the STATUS Register to determine if either accumulator has overflowed, or one bit to determine if either accumulator has saturated. This is useful for complex number arithmetic, which typically uses both accumulators.

The device supports three Saturation and Overflow modes:

- **Bit 39 Overflow and Saturation:**
When bit 39 overflow and saturation occurs, the saturation logic loads the maximally positive 9.31 (0x7FFFFFFFFF) or maximally negative 9.31 value (0x800000000) into the target accumulator. The SA or SB bit is set and remains set until cleared by the user application. This condition is referred to as 'super saturation' and provides protection against erroneous data or unexpected algorithm problems (such as gain calculations).
- **Bit 31 Overflow and Saturation:**
When bit 31 overflow and saturation occurs, the saturation logic then loads the maximally positive 1.31 value (0x007FFFFFFFF) or maximally negative 1.31 value (0x008000000) into the target accumulator. The SA or SB bit is set and remains set until cleared by the user application. When this Saturation mode is in effect, the guard bits are not used, so the OA, OB or OAB bits are never set.
- **Bit 39 Catastrophic Overflow:**
The bit 39 Overflow Status bit from the adder is used to set the SA or SB bit, which remains set until cleared by the user application. No saturation operation is performed, and the accumulator is allowed to overflow, destroying its sign. If the COVTE bit in the INTCON1 register is set, a catastrophic overflow can initiate a trap exception.

3.6.3 ACCUMULATOR 'WRITE BACK'

The MAC class of instructions (with the exception of MPY, MPY.N, ED and EDAC) can optionally write a rounded version of the high word (bits 31 through 16) of the accumulator that is not targeted by the instruction into data space memory. The write is performed across the X bus into combined X and Y address space. The following addressing modes are supported:

- **W13, Register Direct:**
The rounded contents of the non-target accumulator are written into W13 as a 1.15 fraction.
- **[W13] += 2, Register Indirect with Post-Increment:**
The rounded contents of the non-target accumulator are written into the address pointed to by W13 as a 1.15 fraction. W13 is then incremented by 2 (for a word write).

3.6.3.1 Round Logic

The round logic is a combinational block that performs a conventional (biased) or convergent (unbiased) round function during an accumulator write (store). The Round mode is determined by the state of the RND bit in the CORCON register. It generates a 16-bit, 1.15 data value that is passed to the data space write saturation logic. If rounding is not indicated by the instruction, a truncated 1.15 data value is stored and the least significant word is simply discarded.

Conventional rounding zero-extends bit 15 of the accumulator and adds it to the ACCxH word (bits 16 through 31 of the accumulator).

- If the ACCxL word (bits 0 through 15 of the accumulator) is between 0x8000 and 0xFFFF (0x8000 included), ACCxH is incremented.
- If ACCxL is between 0x0000 and 0x7FFF, ACCxH is left unchanged.

A consequence of this algorithm is that over a succession of random rounding operations, the value tends to be biased slightly positive.

Convergent (or unbiased) rounding operates in the same manner as conventional rounding, except when ACCxL equals 0x8000. In this case, the Least Significant bit (bit 16 of the accumulator) of ACCxH is examined:

- If it is '1', ACCxH is incremented.
- If it is '0', ACCxH is not modified.

Assuming that bit 16 is effectively random in nature, this scheme removes any rounding bias that may accumulate.

dsPIC33FJ06GS101/X02 and dsPIC33FJ16GSX02/X04

The `SAC` and `SAC.R` instructions store either a truncated (`SAC`), or rounded (`SAC.R`) version of the contents of the target accumulator to data memory via the X bus, subject to data saturation (see [Section 3.6.3.2 “Data Space Write Saturation”](#)). For the `MAC` class of instructions, the accumulator write-back operation functions in the same manner, addressing combined MCU (X and Y) data space though the X bus. For this class of instructions, the data is always subject to rounding.

3.6.3.2 Data Space Write Saturation

In addition to adder/subtractor saturation, writes to data space can also be saturated, but without affecting the contents of the source accumulator. The data space write saturation logic block accepts a 16-bit, 1.15 fractional value from the round logic block as its input, together with overflow status from the original source (accumulator) and the 16-bit round adder. These inputs are combined and used to select the appropriate 1.15 fractional value as output to write to data space memory.

If the `SATDW` bit in the `CORCON` register is set, data (after rounding or truncation) is tested for overflow and adjusted accordingly:

- For input data greater than `0x007FFF`, data written to memory is forced to the maximum positive 1.15 value, `0x7FFF`.
- For input data less than `0xFF8000`, data written to memory is forced to the maximum negative 1.15 value, `0x8000`.

The Most Significant bit of the source (bit 39) is used to determine the sign of the operand being tested.

If the `SATDW` bit in the `CORCON` register is not set, the input data is always passed through unmodified under all conditions.

3.6.4 BARREL SHIFTER

The barrel shifter can perform up to 16-bit arithmetic or logic right shifts, or up to 16-bit left shifts in a single cycle. The source can be either of the two DSP accumulators or the X bus (to support multi-bit shifts of register or memory data).

The shifter requires a signed binary value to determine both the magnitude (number of bits) and direction of the shift operation. A positive value shifts the operand right. A negative value shifts the operand left. A value of '0' does not modify the operand.

The barrel shifter is 40 bits wide, thereby obtaining a 40-bit result for DSP shift operations and a 16-bit result for MCU shift operations. Data from the X bus is presented to the barrel shifter between bit positions 16 and 31 for right shifts, and between bit positions 0 and 16 for left shifts.

dsPIC33FJ06GS101/X02 and dsPIC33FJ16GSX02/X04

4.0 MEMORY ORGANIZATION

Note: This data sheet summarizes the features of the dsPIC33FJ06GS101/X02 and dsPIC33FJ16GSX02/X04 families of devices. It is not intended to be a comprehensive reference source. To complement the information in this data sheet, refer to **“Program Memory”** (DS70202) in the *“dsPIC33F/PIC24H Family Reference Manual”*, which is available from the Microchip web site (www.microchip.com).

The dsPIC33FJ06GS101/X02 and dsPIC33FJ16GSX02/X04 architecture features separate program and data memory spaces and buses. This architecture also allows the direct access to program memory from the data space during code execution.

4.1 Program Address Space

The program address memory space of the dsPIC33FJ06GS101/X02 and dsPIC33FJ16GSX02/X04 devices is 4M instructions. The space is addressable by a 24-bit value derived either from the 23-bit Program Counter (PC) during program execution, or from table operation or data space remapping, as described in [Section 4.6 “Interfacing Program and Data Memory Spaces”](#).

User application access to the program memory space is restricted to the lower half of the address range (0x000000 to 0x7FFFFFFF). The exception is the use of TBLRD/TBLWT operations, which use TBLPAG<7> to permit access to the Configuration bits and Device ID sections of the configuration memory space.

The memory maps for the dsPIC33FJ06GS101/X02 and dsPIC33FJ16GSX02/X04 devices are shown in [Figure 4-1](#).

FIGURE 4-1: PROGRAM MEMORY MAPS FOR dsPIC33FJ06GS101/X02 and dsPIC33FJ16GSX02/X04 DEVICES



dsPIC33FJ06GS101/X02 and dsPIC33FJ16GSX02/X04

4.1.1 PROGRAM MEMORY ORGANIZATION

The program memory space is organized in word-addressable blocks. Although it is treated as 24 bits wide, it is more appropriate consider each address of the program memory as a lower and upper word, with the upper byte of the upper word being unimplemented. The lower word always has an even address, while the upper word has an odd address (see [Figure 4-2](#)).

Program memory addresses are always word-aligned on the lower word, and addresses are incremented or decremented by two during the code execution. This arrangement provides compatibility with data memory space addressing and makes data in the program memory space accessible.

4.1.2 INTERRUPT AND TRAP VECTORS

All dsPIC33FJ06GS101/X02 and dsPIC33FJ16GSX02/X04 devices reserve the addresses between 0x00000 and 0x000200 for hard-coded program execution vectors. A hardware Reset vector is provided to redirect code execution from the default value of the PC on device Reset to the actual start of code. A GOTO instruction is programmed by the user application at 0x000000, with the actual address for the start of code at 0x000002.

The dsPIC33FJ06GS101/X02 and dsPIC33FJ16GSX02/X04 devices also have two interrupt vector tables, located from 0x000004 to 0x0000FF and 0x000100 to 0x0001FF. These vector tables allow each of the device interrupt sources to be handled by separate Interrupt Service Routines (ISRs). A more detailed discussion of the interrupt vector tables is provided in [Section 7.1 "Interrupt Vector Table"](#).

FIGURE 4-2: PROGRAM MEMORY ORGANIZATION



4.2 Data Address Space

The dsPIC33FJ06GS101/X02 and dsPIC33FJ16GSX02/X04 CPU has a separate, 16-bit-wide data memory space. The data space is accessed using separate Address Generation Units (AGUs) for read and write operations. The data memory maps is shown in Figure 4-3.

All Effective Addresses (EAs) in the data memory space are 16 bits wide and point to bytes within the data space. This arrangement gives a data space address range of 64 Kbytes or 32K words. The lower half of the data memory space (that is, when $EA_{15} = 0$) is used for implemented memory addresses, while the upper half ($EA_{15} = 1$) is reserved for the Program Space Visibility area (see Section 4.6.3 “Reading Data from Program Memory Using Program Space Visibility”).

dsPIC33FJ06GS101/X02 and dsPIC33FJ16GSX02/X04 devices implement up to 2 Kbytes of data memory. Should an EA point to a location outside of this area, an all zero word or byte will be returned.

4.2.1 DATA SPACE WIDTH

The data memory space is organized in byte addressable, 16-bit wide blocks. Data is aligned in data memory and registers as 16-bit words, but all data space EAs resolve to bytes. The Least Significant Bytes (LSBs) of each word have even addresses, while the Most Significant Bytes (MSBs) have odd addresses.

4.2.2 DATA MEMORY ORGANIZATION AND ALIGNMENT

To maintain backward compatibility with PIC[®] MCU devices and improve data space memory usage efficiency, the dsPIC33FJ06GS101/X02 and dsPIC33FJ16GSX02/X04 instruction set supports both word and byte operations. As a consequence of byte accessibility, all Effective Address calculations are internally scaled to step through word-aligned memory. For example, the core recognizes that Post-Modified Register Indirect Addressing mode [Ws++] that results in a value of Ws + 1 for byte operations and Ws + 2 for word operations.

Data byte reads will read the complete word that contains the byte, using the LSB of any EA to determine which byte to select. The selected byte is placed onto the LSB of the data path. That is, data memory and registers are organized as two parallel byte-wide entities with shared (word) address decode but separate write lines. Data byte writes only write to the corresponding side of the array or register that matches the byte address.

All word accesses must be aligned to an even address. Misaligned word data fetches are not supported, so care must be taken when mixing byte and word operations, or translating from 8-bit MCU code. If a misaligned read or write is attempted, an address error trap is generated. If the error occurred on a read, the instruction underway is completed. If the error occurred on a write, the instruction is executed but the write does not occur. In either case, a trap is then executed, allowing the system and/or user application to examine the machine state prior to execution of the address Fault.

All byte loads into any W register are loaded into the Least Significant Byte. The Most Significant Byte is not modified.

A sign-extend (SE) instruction is provided to allow user applications to translate 8-bit signed data to 16-bit signed values. Alternatively, for 16-bit unsigned data, user applications can clear the MSB of any W register by executing a zero-extend (ZE) instruction on the appropriate address.

4.2.3 SFR SPACE

The first 2 Kbytes of the Near Data Space, from 0x0000 to 0x07FF, is primarily occupied by Special Function Registers (SFRs). These are used by the dsPIC33FJ06GS101/X02 and dsPIC33FJ16GSX02/X04 core and peripheral modules for controlling the operation of the device.

SFRs are distributed among the modules that they control, and are generally grouped together by module. Much of the SFR space contains unused addresses; these are read as ‘0’.

Note: The actual set of peripheral features and interrupts varies by the device. Refer to the corresponding device tables and pinout diagrams for device-specific information.

4.2.4 NEAR DATA SPACE

The 8-Kbyte area, between 0x0000 and 0x1FFF, is referred to as the Near Data Space. Locations in this space are directly addressable via a 13-bit absolute address field within all memory direct instructions. Additionally, the whole data space is addressable using MOV instructions, which support Memory Direct Addressing mode with a 16-bit address field or by using Indirect Addressing mode using a Working register as an Address Pointer.

dsPIC33FJ06GS101/X02 and dsPIC33FJ16GSX02/X04

FIGURE 4-3: DATA MEMORY MAP FOR dsPIC33FJ06GS101/102 DEVICES WITH 256 BYTES OF RAM



dsPIC33FJ06GS101/X02 and dsPIC33FJ16GSX02/X04

FIGURE 4-4: DATA MEMORY MAP FOR dsPIC33FJ06GS202 DEVICE WITH 1-KBYTE RAM



dsPIC33FJ06GS101/X02 and dsPIC33FJ16GSX02/X04

FIGURE 4-5: DATA MEMORY MAP FOR dsPIC33FJ16GS402/404/502/504 DEVICES WITH 2-KBYTE RAM

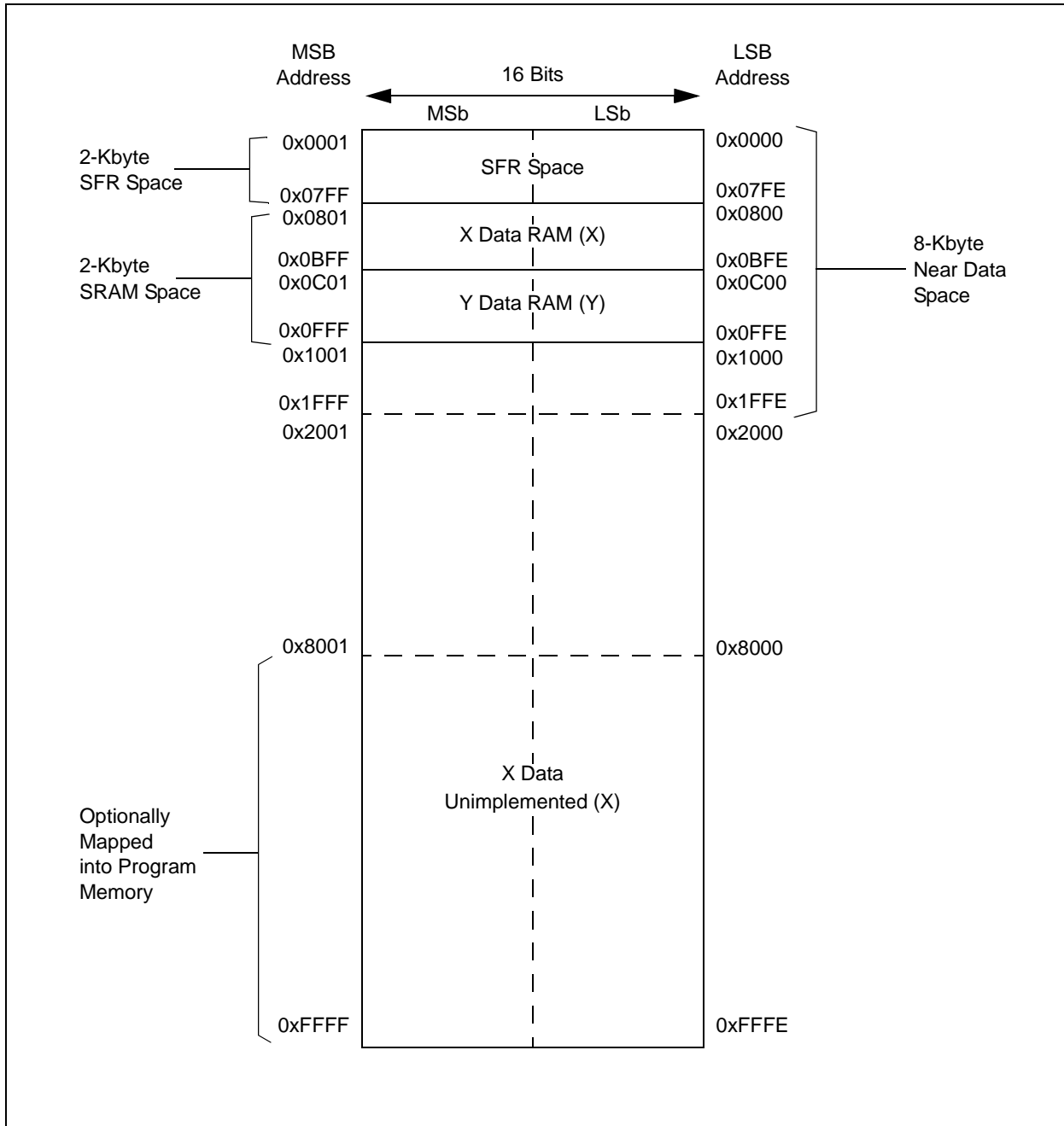

dsPIC33FJ06GS101/X02 and dsPIC33FJ16GSX02/X04

4.2.5 X AND Y DATA SPACES

The core has two data spaces, X and Y. These data spaces can be considered either separate (for some DSP instructions), or as one unified linear address range (for MCU instructions). The data spaces are accessed using two Address Generation Units (AGUs) and separate data paths. This feature allows certain instructions to concurrently fetch two words from RAM, thereby enabling efficient execution of DSP algorithms, such as Finite Impulse Response (FIR) filtering and Fast Fourier Transform (FFT).

The X data space is used by all instructions and supports all addressing modes. X data space has separate read and write data buses. The X read data bus is the read data path for all instructions that view data space as combined X and Y address space. It is also the X data prefetch path for the dual operand DSP instructions (MAC class).

The Y data space is used in concert with the X data space by the MAC class of instructions (CLR, ED, EDAC, MAC, MOVSA, MPY, MPY.N and MSC) to provide two concurrent data read paths.

Both the X and Y data spaces support Modulo Addressing mode for all instructions, subject to addressing mode restrictions. Bit-Reversed Addressing mode is only supported for writes to X data space.

All data memory writes, including in DSP instructions, view data space as combined X and Y address space. The boundary between the X and Y data spaces is device-dependent and is not user-programmable.

All Effective Addresses are 16 bits wide and point to bytes within the data space. Therefore, the data space address range is 64 Kbytes, or 32K words, though the implemented memory locations vary by device.

TABLE 4-1: CPU CORE REGISTER MAP

File Name	SFR Addr	Bit 15	Bit 14	Bit 13	Bit 12	Bit 11	Bit 10	Bit 9	Bit 8	Bit 7	Bit 6	Bit 5	Bit 4	Bit 3	Bit 2	Bit 1	Bit 0	All Resets	
WREG0	0000	Working Register 0																0000	
WREG1	0002	Working Register 1																0000	
WREG2	0004	Working Register 2																0000	
WREG3	0006	Working Register 3																0000	
WREG4	0008	Working Register 4																0000	
WREG5	000A	Working Register 5																0000	
WREG6	000C	Working Register 6																0000	
WREG7	000E	Working Register 7																0000	
WREG8	0010	Working Register 8																0000	
WREG9	0012	Working Register 9																0000	
WREG10	0014	Working Register 10																0000	
WREG11	0016	Working Register 11																0000	
WREG12	0018	Working Register 12																0000	
WREG13	001A	Working Register 13																0000	
WREG14	001C	Working Register 14																0000	
WREG15	001E	Working Register 15																0800	
SPLIM	0020	Stack Pointer Limit Register																xxxx	
ACCAL	0022	ACCAL																xxxx	
ACCAH	0024	ACCAH																xxxx	
ACCAU	0026	ACCA<39>	ACCA<39>	ACCA<39>	ACCA<39>	ACCA<39>	ACCA<39>	ACCA<39>	ACCA<39>	ACCA<39>	ACCA<39>	ACCA<39>	ACCAU					xxxx	
ACCBL	0028	ACCBL																xxxx	
ACCBH	002A	ACCBH																xxxx	
ACCBU	002C	ACCB<39>	ACCB<39>	ACCB<39>	ACCB<39>	ACCB<39>	ACCB<39>	ACCB<39>	ACCB<39>	ACCB<39>	ACCB<39>	ACCBU					xxxx		
PCL	002E	Program Counter Low Word Register																0000	
PCH	0030	—	—	—	—	—	—	—	—	—	—	Program Counter High Byte Register				0000			
TBLPAG	0032	—	—	—	—	—	—	—	—	—	Table Page Address Pointer Register						0000		
PSVPAG	0034	—	—	—	—	—	—	—	—	—	Program Memory Visibility Page Address Pointer Register						0000		
RCOUNT	0036	REPEAT Loop Counter Register																xxxx	
DCOUNT	0038	DCOUNT<15:0>																xxxx	
DOSTARTL	003A	DOSTARTL<15:1>																0	xxxx
DOSTARTH	003C	—	—	—	—	—	—	—	—	—	—	DOSTARTH<5:0>				00xx			
DOENDL	003E	DOENDL<15:1>																0	xxxx
DOENDH	0040	—	—	—	—	—	—	—	—	—	—	DOENDH				00xx			
SR	0042	OA	OB	SA	SB	OAB	SAB	DA	DC	IPL2	IPL1	IPL0	RA	N	OV	Z	C	0000	
CORCON	0044	—	—	—	US	EDT	DL2	DL1	DL0	SATA	SATB	SATDW	ACCSAT	IPL3	PSV	RND	IF	0020	
MODCON	0046	XMODEN	YMODEN	—	—	BWM3	BWM2	BWM1	BWM0	YWM3	YWM2	YWM1	YWM0	XWM3	XWM2	XWM1	XWM0	0000	

Legend: x = unknown value on Reset, — = unimplemented, read as '0'. Reset values are shown in hexadecimal.

TABLE 4-1: CPU CORE REGISTER MAP (CONTINUED)

File Name	SFR Addr	Bit 15	Bit 14	Bit 13	Bit 12	Bit 11	Bit 10	Bit 9	Bit 8	Bit 7	Bit 6	Bit 5	Bit 4	Bit 3	Bit 2	Bit 1	Bit 0	All Resets	
XMODSRT	0048	XS<15:1>																0	xxxxx
XMODEND	004A	XE<15:1>																1	xxxxx
YMODSRT	004C	YS<15:1>																0	xxxxx
YMODEND	004E	YE<15:1>																1	xxxxx
XBREV	0050	BREN	XB14	XB13	XB12	XB11	XB10	XB9	XB8	XB7	XB6	XB5	XB4	XB3	XB2	XB1	XB0	xxxxx	
DISICNT	0052	Disable Interrupts Counter Register																	xxxxx

Legend: x = unknown value on Reset, — = unimplemented, read as '0'. Reset values are shown in hexadecimal.

TABLE 4-2: CHANGE NOTIFICATION REGISTER MAP FOR dsPIC33FJ06GS101

File Name	SFR Addr	Bit 15	Bit 14	Bit 13	Bit 12	Bit 11	Bit 10	Bit 9	Bit 8	Bit 7	Bit 6	Bit 5	Bit 4	Bit 3	Bit 2	Bit 1	Bit 0	All Resets
CNEN1	0060	—	—	—	—	—	—	—	—	CN7IE	CN6IE	CN5IE	CN4IE	CN3IE	CN2IE	CN1IE	CN0IE	0000
CNPU1	0068	—	—	—	—	—	—	—	—	CN7PUE	CN6PUE	CN5PUE	CN4PUE	CN3PUE	CN2PUE	CN1PUE	CN0PUE	0000

Legend: x = unknown value on Reset, — = unimplemented, read as '0'. Reset values are shown in hexadecimal.

TABLE 4-3: CHANGE NOTIFICATION REGISTER MAP FOR dsPIC33FJ06GS102, dsPIC33FJ06GS202, dsPIC33FJ16GS402 AND dsPIC33FJ16GS502

File Name	SFR Addr	Bit 15	Bit 14	Bit 13	Bit 12	Bit 11	Bit 10	Bit 9	Bit 8	Bit 7	Bit 6	Bit 5	Bit 4	Bit 3	Bit 2	Bit 1	Bit 0	All Resets
CNEN1	0060	CN15IE	CN14IE	CN13IE	CN12IE	CN11IE	CN10IE	CN9IE	CN8IE	CN7IE	CN6IE	CN5IE	CN4IE	CN3IE	CN2IE	CN1IE	CN0IE	0000
CNPU1	0068	CN15PUE	CN14PUE	CN13PUE	CN12PUE	CN11PUE	CN10PUE	CN9PUE	CN8PUE	CN7PUE	CN6PUE	CN5PUE	CN4PUE	CN3PUE	CN2PUE	CN1PUE	CN0PUE	0000

Legend: x = unknown value on Reset, — = unimplemented, read as '0'. Reset values are shown in hexadecimal.

TABLE 4-4: CHANGE NOTIFICATION REGISTER MAP FOR dsPIC33FJ16GS404 AND dsPIC33FJ16GS504

File Name	SFR Addr	Bit 15	Bit 14	Bit 13	Bit 12	Bit 11	Bit 10	Bit 9	Bit 8	Bit 7	Bit 6	Bit 5	Bit 4	Bit 3	Bit 2	Bit 1	Bit 0	All Resets
CNEN1	0060	CN15IE	CN14IE	CN13IE	CN12IE	CN11IE	CN10IE	CN9IE	CN8IE	CN7IE	CN6IE	CN5IE	CN4IE	CN3IE	CN2IE	CN1IE	CN0IE	0000
CNEN2	0062	—	—	CN29IE	CN28IE	CN27IE	CN26IE	CN25IE	CN24IE	CN23IE	CN22IE	CN21IE	CN20IE	CN19IE	CN18IE	CN17IE	CN16IE	0000
CNPU1	0068	CN15PUE	CN14PUE	CN13PUE	CN12PUE	CN11PUE	CN10PUE	CN9PUE	CN8PUE	CN7PUE	CN6PUE	CN5PUE	CN4PUE	CN3PUE	CN2PUE	CN1PUE	CN0PUE	0000
CNPU2	006A	—	—	CN29PUE	CN28PUE	CN27PUE	CN26PUE	CN25PUE	CN24PUE	CN23PUE	CN22PUE	CN21PUE	CN20PUE	CN19PUE	CN18PUE	CN17PUE	CN16PUE	0000

Legend: x = unknown value on Reset, — = unimplemented, read as '0'. Reset values are shown in hexadecimal.

TABLE 4-5: INTERRUPT CONTROLLER REGISTER MAP FOR dsPIC33FJ06GS101 DEVICES ONLY

File Name	SFR Addr	Bit 15	Bit 14	Bit 13	Bit 12	Bit 11	Bit 10	Bit 9	Bit 8	Bit 7	Bit 6	Bit 5	Bit 4	Bit 3	Bit 2	Bit 1	Bit 0	All Resets	
INTCON1	0080	NSTDIS	OVAERR	OVBERR	COVAERR	COVBERR	OVATE	OVBTE	COVTE	SFTACERR	DIV0ERR	—	MATHERR	ADDRERR	STKERR	OSCFAIL	—	0000	
INTCON2	0082	ALTIPT	DISI	—	—	—	—	—	—	—	—	—	—	—	INT2EP	INT1EP	INT0EP	0000	
IFS0	0084	—	—	ADIF	U1TXIF	U1RXIF	SPI1IF	SP1EIF	—	T2IF	—	—	—	T1IF	OC1IF	—	INT0IF	0000	
IFS1	0086	—	—	INT2IF	—	—	—	—	—	—	—	—	INT1IF	CNIF	—	MI2C1IF	SI2C1IF	0000	
IFS3	008A	—	—	—	—	—	—	PSEMIF	—	—	—	—	—	—	—	—	—	0000	
IFS4	008C	—	—	—	—	—	—	—	—	—	—	—	—	—	—	U1EIF	—	0000	
IFS5	008E	—	PWM1IF	—	—	—	—	—	—	—	—	—	—	—	—	—	—	0000	
IFS6	0090	ADCP1IF	ADCP0IF	—	—	—	—	—	—	—	—	—	—	—	—	PWM4IF	—	0000	
IFS7	0092	—	—	—	—	—	—	—	—	—	—	—	—	—	—	ADCP3IF	—	0000	
IEC0	0094	—	—	ADIE	U1TXIE	U1RXIE	SPI1IE	SP1EIE	—	T2IE	—	—	—	T1IE	OC1IE	—	INT0IE	0000	
IEC1	0096	—	—	INT2IE	—	—	—	—	—	—	—	—	—	INT1IE	CNIE	—	MI2C1IE	SI2C1IE	0000
IEC2	0098	—	—	—	—	—	—	—	—	—	—	—	—	—	—	—	—	0000	
IEC3	009A	—	—	—	—	—	—	PSEMIE	—	—	—	—	—	—	—	—	—	0000	
IEC4	009C	—	—	—	—	—	—	—	—	—	—	—	—	—	—	U1EIE	—	0000	
IEC5	009E	—	PWM1IE	—	—	—	—	—	—	—	—	—	—	—	—	—	—	0000	
IEC6	00A0	ADCP1IE	ADCP0IE	—	—	—	—	—	—	—	—	—	—	—	—	PWM4IE	—	0000	
IEC7	00A2	—	—	—	—	—	—	—	—	—	—	—	—	—	—	ADCP3IE	—	0000	
IPC0	00A4	—	T1IP2	T1IP1	T1IP0	—	OC1IP2	OC1IP1	OC1IP0	—	—	—	—	—	—	INT0IP2	INT0IP1	INT0IP0	4404
IPC1	00A6	—	T2IP2	T2IP1	T2IP0	—	—	—	—	—	—	—	—	—	—	—	—	—	4000
IPC2	00A8	—	U1RXIP2	U1RXIP1	U1RXIP0	—	SPI1IP2	SPI1IP1	SPI1IP0	—	SPI1EIP2	SPI1EIP1	SPI1EIP0	—	—	—	—	—	4440
IPC3	00AA	—	—	—	—	—	—	—	—	—	ADIP2	ADIP1	ADIP0	—	U1TXIP2	U1TXIP1	U1TXIP0	0044	
IPC4	00AC	—	CNIP2	CNIP1	CNIP0	—	—	—	—	—	MI2C1IP2	MI2C1IP1	MI2C1IP0	—	SI2C1IP2	SI2C1IP1	SI2C1IP0	4044	
IPC5	00AE	—	—	—	—	—	—	—	—	—	—	—	—	—	INT1IP2	INT1IP1	INT1IP0	0004	
IPC7	00B2	—	—	—	—	—	—	—	—	—	INT2IP2	INT2IP1	INT2IP0	—	—	—	—	0040	
IPC14	00C0	—	—	—	—	—	—	—	—	—	PSEMIP2	PSEMIP1	PSEMIP0	—	—	—	—	0040	
IPC16	00C4	—	—	—	—	—	—	—	—	—	U1EIP2	U1EIP1	U1EIP0	—	—	—	—	0400	
IPC23	00D2	—	—	—	—	—	PWM1IP2	PWM1IP1	PWM1IP0	—	—	—	—	—	—	—	—	0040	
IPC24	00D4	—	—	—	—	—	—	—	—	—	PWM4IP2	PWM4IP1	PWM4IP0	—	—	—	—	4400	
IPC27	00DA	—	ADCP1IP2	ADCP1IP1	ADCP1IP0	—	ADCP0IP2	ADCP0IP1	ADCP0IP0	—	—	—	—	—	—	—	—	0040	
IPC28	00DC	—	—	—	—	—	—	—	—	—	ADCP3IP2	ADCP3IP1	ADCP3IP0	—	—	—	—	0000	
INTTREG	00E0	—	—	—	—	ILR3	ILR2	ILR1	ILR0	—	VECNUM6	VECNUM5	VECNUM4	VECNUM3	VECNUM2	VECNUM1	VECNUM0	0000	

Legend: x = unknown value on Reset, — = unimplemented, read as '0'. Reset values are shown in hexadecimal.

TABLE 4-6: INTERRUPT CONTROLLER REGISTER MAP FOR dsPIC33FJ06GS102 DEVICES ONLY

File Name	SFR Addr	Bit 15	Bit 14	Bit 13	Bit 12	Bit 11	Bit 10	Bit 9	Bit 8	Bit 7	Bit 6	Bit 5	Bit 4	Bit 3	Bit 2	Bit 1	Bit 0	All Resets
INTCON1	0080	NSTDIS	OVAERR	OVBERR	COVAERR	COVBERR	OVATE	OVBTE	COVTE	SFTACERR	DIV0ERR	—	MATHERR	ADDRERR	STKERR	OSCFail	—	0000
INTCON2	0082	ALTVT	DISI	—	—	—	—	—	—	—	—	—	—	—	INT2EP	INT1EP	INT0EP	0000
IFS0	0084	—	—	ADIF	U1TXIF	U1RXIF	SP1IF	SP1EIF	—	T2IF	—	—	—	T1IF	OC1IF	—	INT0IF	0000
IFS1	0086	—	—	INT2IF	—	—	—	—	—	—	—	—	INT1IF	CNIF	—	M12C1IF	SI2C1IF	0000
IFS3	008A	—	—	—	—	—	—	PSEMIF	—	—	—	—	—	—	—	—	—	0000
IFS4	008C	—	—	—	—	—	—	—	—	—	—	—	—	—	—	U1EIF	—	0000
IFS5	008E	PWM2IF	PWM1IF	—	—	—	—	—	—	—	—	—	—	—	—	—	—	0000
IFS6	0090	ADCP1IF	ADCP0IF	—	—	—	—	—	—	—	—	—	—	—	—	—	—	0000
IFS7	0092	—	—	—	—	—	—	—	—	—	—	—	—	—	—	—	ADCP2IF	0000
IEC0	0094	—	—	ADIE	U1TXIE	U1RXIE	SP1IE	SP1EIE	—	T2IE	—	—	—	T1IE	OC1IE	—	INT0IE	0000
IEC1	0096	—	—	INT2IE	—	—	—	—	—	—	—	—	INT1IE	CNIE	—	M12C1IE	SI2C1IE	0000
IEC3	009A	—	—	—	—	—	—	PSEMIE	—	—	—	—	—	—	—	—	—	0000
IEC4	009C	—	—	—	—	—	—	—	—	—	—	—	—	—	—	U1EIE	—	0000
IEC5	009E	PWM2IE	PWM1IE	—	—	—	—	—	—	—	—	—	—	—	—	—	—	0000
IEC6	00A0	ADCP1IE	ADCP0IE	—	—	—	—	—	—	—	—	—	—	—	—	—	—	0000
IEC7	00A2	—	—	—	—	—	—	—	—	—	—	—	—	—	—	—	ADCP2IE	0000
IPC0	00A4	—	T1IP2	T1IP1	T1IP0	—	OC1IP2	OC1IP1	OC1IP0	—	—	—	—	—	INT0IP2	INT0IP1	INT0IP0	4404
IPC1	00A6	—	T2IP2	T2IP1	T2IP0	—	—	—	—	—	—	—	—	—	—	—	—	4000
IPC2	00A8	—	U1RXIP2	U1RXIP2	U1RXIP0	—	SP1IP2	SP1IP1	SP1IP0	—	SP1EIP2	SP1EIP1	SP1EIP0	—	—	—	—	4440
IPC3	00AA	—	—	—	—	—	—	—	—	—	ADIP2	ADIP1	ADIP0	—	U1TXIP2	U1TXIP1	U1TXIP0	0044
IPC4	00AC	—	CNIP2	CNIP1	CNIP0	—	—	—	—	—	M12C1IP2	M12C1IP1	M12C1IP0	—	SI2C1IP2	SI2C1IP1	SI2C1IP0	4044
IPC5	00AE	—	—	—	—	—	—	—	—	—	—	—	—	—	INT1IP2	INT1IP1	INT1IP0	0004
IPC7	00B2	—	—	—	—	—	—	—	—	—	INT2IP2	INT2IP1	INT2IP0	—	—	—	—	0040
IPC14	00C0	—	—	—	—	—	—	—	—	—	PSEMIP2	PSEMIP1	PSEMIP0	—	—	—	—	0040
IPC16	00C4	—	—	—	—	—	—	—	—	—	U1EIP2	U1EIP1	U1EIP0	—	—	—	—	0040
IPC23	00D2	—	PWM2IP2	PWM2IP1	PWM2IP0	—	PWM1IP2	PWM1IP1	PWM1IP0	—	—	—	—	—	—	—	—	4400
IPC27	00DA	—	ADCP1IP2	ADCP1IP1	ADCP1IP0	—	ADCP0IP2	ADCP0IP1	ADCP0IP0	—	—	—	—	—	—	—	—	4400
IPC28	00DC	—	—	—	—	—	—	—	—	—	—	—	—	—	ADCP2IP2	ADCP2IP1	ADCP2IP0	0004
INTTREG	00E0	—	—	—	—	ILR3	ILR2	ILR1	ILR0	—	VECNUM6	VECNUM5	VECNUM4	VECNUM3	VECNUM2	VECNUM1	VECNUM0	0000

Legend: x = unknown value on Reset, — = unimplemented, read as '0'. Reset values are shown in hexadecimal.

TABLE 4-7: INTERRUPT CONTROLLER REGISTER MAP FOR dsPIC33FJ06G202 DEVICES ONLY

File Name	SFR Addr	Bit 15	Bit 14	Bit 13	Bit 12	Bit 11	Bit 10	Bit 9	Bit 8	Bit 7	Bit 6	Bit 5	Bit 4	Bit 3	Bit 2	Bit 1	Bit 0	All Resets
INTCON1	0080	NSTDIS	OVAERR	OVBERR	COVAERR	COVBERR	OVATE	OVBTE	COVTE	SFTACERR	DIV0ERR	—	MATHERR	ADDRERR	STKERR	OSCFAIL	—	0000
INTCON2	0082	ALTIVT	DISI	—	—	—	—	—	—	—	—	—	—	—	INT2EP	INT1EP	INT0EP	0000
IFS0	0084	—	—	ADIF	U1TXIF	U1RXIF	SPI1IF	SPI1EIF	—	T2IF	—	—	—	T1IF	OC1IF	IC1IF	INT0IF	0000
IFS1	0086	—	—	INT2IF	—	—	—	—	—	—	—	—	INT1IF	CNIF	AC1IF	MI2C1IF	SI2C1IF	0000
IFS3	008A	—	—	—	—	—	—	PSEMIIF	—	—	—	—	—	—	—	—	—	0000
IFS4	008C	—	—	—	—	—	—	—	—	—	—	—	—	—	—	U1EIF	—	0000
IFS5	008E	PWM2IF	PWM1IF	—	—	—	—	—	—	—	—	—	—	—	—	—	—	0000
IFS6	0090	ADCP1IF	ADCP0IF	—	—	—	—	—	—	AC2IF	—	—	—	—	—	—	—	0000
IFS7	0092	—	—	—	—	—	—	—	—	—	—	—	ADCP6IF	—	—	—	ADCP2IF	0000
IEC0	0094	—	—	ADIE	U1TXIE	U1RXIE	SPI1IE	SPI1EIE	—	T2IE	—	—	—	T1IE	OC1IE	IC1IE	INT0IE	0000
IEC1	0096	—	—	INT2IE	—	—	—	—	—	—	—	—	INT1IE	CNIE	AC1IE	MI2C1IE	SI2C1IE	0000
IEC3	009A	—	—	—	—	—	—	PSEMIIE	—	—	—	—	—	—	—	—	—	0000
IEC4	009C	—	—	—	—	—	—	—	—	—	—	—	—	—	—	U1EIE	—	0000
IEC5	009E	PWM2IE	PWM1IE	—	—	—	—	—	—	—	—	—	—	—	—	—	—	0000
IEC6	00A0	ADCP1IE	ADCP0IE	—	—	—	—	—	—	AC2IE	—	—	—	—	—	—	—	0000
IEC7	00A2	—	—	—	—	—	—	—	—	—	—	—	ADCP6IE	—	—	—	ADCP2IE	0000
IPC0	00A4	—	T1IP2	T1IP1	T1IP0	—	OC1IP2	OC1IP1	OC1IP0	—	IC1IP2	IC1IP1	IC1IP0	—	INT0IP2	INT0IP1	INT0IP0	4444
IPC1	00A6	—	T2IP2	T2IP1	T2IP0	—	—	—	—	—	—	—	—	—	—	—	—	4000
IPC2	00A8	—	U1RXIP2	U1RXIP1	U1RXIP0	—	SPI1IP2	SPI1IP1	SPI1IP0	—	SPI1EIP2	SPI1EIP1	SPI1EIP0	—	—	—	—	4440
IPC3	00AA	—	—	—	—	—	—	—	—	—	ADIP2	ADIP1	ADIP0	—	U1TXIP2	U1TXIP1	U1TXIP0	0044
IPC4	00AC	—	CNIP2	CNIP1	CNIP0	—	AC1IP2	AC1IP1	AC1IP0	—	MI2C1IP2	MI2C1IP1	MI2C1IP0	—	SI2C1IP2	SI2C1IP1	SI2C1IP0	4444
IPC5	00AE	—	—	—	—	—	—	—	—	—	—	—	—	—	INT1IP2	INT1IP1	INT1IP0	0004
IPC7	00B2	—	—	—	—	—	—	—	—	—	INT2IP2	INT2IP1	INT2IP0	—	—	—	—	0040
IPC14	00C0	—	—	—	—	—	—	—	—	—	PSEMIP2	PSEMIP1	PSEMIP0	—	—	—	—	0040
IPC16	00C4	—	—	—	—	—	—	—	—	—	U1EIP2	U1EIP1	U1EIP0	—	—	—	—	0040
IPC23	00D2	—	PWM2IP2	PWM2IP1	PWM2IP0	—	PWM1IP2	PWM1IP1	PWM1IP0	—	—	—	—	—	—	—	—	4400
IPC25	00D6	—	AC2IP2	AC2IP1	AC2IP0	—	—	—	—	—	—	—	—	—	—	—	—	4000
IPC27	00DA	—	ADCP1IP2	ADCP1IP1	ADCP1IP0	—	ADCP0IP2	ADCP0IP1	ADCP0IP0	—	—	—	—	—	—	—	—	4400
IPC28	00DC	—	—	—	—	—	—	—	—	—	—	—	—	—	ADCP2IP2	ADCP2IP1	ADCP2IP0	0004
IPC29	00DE	—	—	—	—	—	—	—	—	—	—	—	—	—	ADCP6IP2	ADCP6IP1	ADCP6IP0	0004
INTTREG	00E0	—	—	—	—	ILR3	ILR2	ILR1	ILR0	—	VECNUM6	VECNUM5	VECNUM4	VECNUM3	VECNUM2	VECNUM1	VECNUM0	0000

Legend: x = unknown value on Reset, — = unimplemented, read as '0'. Reset values are shown in hexadecimal.

TABLE 4-8: INTERRUPT CONTROLLER REGISTER MAP FOR dsPIC33FJ16GS402/404 DEVICES ONLY

File Name	SFR Addr	Bit 15	Bit 14	Bit 13	Bit 12	Bit 11	Bit 10	Bit 9	Bit 8	Bit 7	Bit 6	Bit 5	Bit 4	Bit 3	Bit 2	Bit 1	Bit 0	All Resets	
INTCON1	0080	NSTDIS	OVAERR	OVBERR	COVAERR	COVBERR	OVATE	OVBTE	COVTE	SFTACERR	DIV0ERR	—	MATHERR	ADDRERR	STKERR	OSCFAIL	—	0000	
INTCON2	0082	ALTIVT	DISI	—	—	—	—	—	—	—	—	—	—	—	INT2EP	INT1EP	INT0EP	0000	
IFS0	0084	—	—	ADIF	U1TXIF	U1RXIF	SPI1IF	SPI1EIF	T3IF	T2IF	OC2IF	IC2IF	—	T1IF	OC1IF	IC1IF	INT0IF	0000	
IFS1	0086	—	—	INT2IF	—	—	—	—	—	—	—	—	—	INT1IF	CNIF	—	MI2C1IF	SI2C1IF	0000
IFS3	008A	—	—	—	—	—	—	PSEMIF	—	—	—	—	—	—	—	—	—	—	0000
IFS4	008C	—	—	—	—	—	—	—	—	—	—	—	—	—	—	—	U1EIF	—	0000
IFS5	008E	PWM2IF	PWM1IF	—	—	—	—	—	—	—	—	—	—	—	—	—	—	—	0000
IFS6	0090	ADCP1IF	ADCP0IF	—	—	—	—	—	—	—	—	—	—	—	—	—	—	PWM3IF	0000
IFS7	0092	—	—	—	—	—	—	—	—	—	—	—	—	—	—	—	ADCP3IF	ADCP2IF	0000
IEC0	0094	—	—	ADIE	U1TXIE	U1RXIE	SPI1IE	SPI1EIE	T3IE	T2IE	OC2IE	IC2IE	—	T1IE	OC1IE	IC1IE	INT0IE	0000	
IEC1	0096	—	—	INT2IE	—	—	—	—	—	—	—	—	—	INT1IE	CNIE	—	MI2C1IE	SI2C1IE	0000
IEC3	009A	—	—	—	—	—	—	PSEMIE	—	—	—	—	—	—	—	—	—	—	0000
IEC4	009C	—	—	—	—	—	—	—	—	—	—	—	—	—	—	—	U1EIE	—	0000
IEC5	009E	PWM2IE	PWM1IE	—	—	—	—	—	—	—	—	—	—	—	—	—	—	—	0000
IEC6	00A0	ADCP1IE	ADCP0IE	—	—	—	—	—	—	—	—	—	—	—	—	—	—	PWM3IE	0000
IEC7	00A2	—	—	—	—	—	—	—	—	—	—	—	—	—	—	—	ADCP3IE	ADCP2IE	0000
IPC0	00A4	—	T1IP2	T1IP1	T1IP0	—	OC1IP2	OC1IP1	OC1IP0	—	IC1IP2	IC1IP1	IC1IP0	—	INT0IP2	INT0IP1	INT0IP0	4444	
IPC1	00A6	—	T2IP2	T2IP1	T2IP0	—	OC2IP2	OC2IP1	OC2IP0	—	IC2IP2	IC2IP1	IC2IP0	—	—	—	—	—	4440
IPC2	00A8	—	U1RXIP2	U1RXIP1	U1RXIP0	—	SPI1IP2	SPI1IP1	SPI1IP0	—	SPI1EIP2	SPI1EIP1	SPI1EIP0	—	T3IP2	T3IP1	T3IP0	4444	
IPC3	00AA	—	—	—	—	—	—	—	—	—	ADIP2	ADIP1	ADIP0	—	U1TXIP2	U1TXIP1	U1TXIP0	0044	
IPC4	00AC	—	CNIP2	CNIP1	CNIP0	—	—	—	—	—	MI2C1IP2	MI2C1IP1	MI2C1IP0	—	SI2C1IP2	SI2C1IP1	SI2C1IP0	4044	
IPC5	00AE	—	—	—	—	—	—	—	—	—	—	—	—	—	INT1IP2	INT1IP1	INT1IP0	0004	
IPC7	00B2	—	—	—	—	—	—	—	—	—	INT2IP2	INT2IP1	INT2IP0	—	—	—	—	—	0040
IPC14	00C0	—	—	—	—	—	—	—	—	—	PSEMIP2	PSEMIP1	PSEMIP0	—	—	—	—	—	0040
IPC16	00C4	—	—	—	—	—	—	—	—	—	U1EIP2	U1EIP1	U1EIP0	—	—	—	—	—	0040
IPC23	00D2	—	PWM2IP2	PWM2IP1	PWM2IP0	—	PWM1IP2	PWM1IP1	PWM1IP0	—	—	—	—	—	—	—	—	—	4400
IPC24	00D4	—	—	—	—	—	—	—	—	—	—	—	—	—	PWM3IP2	PWM3IP1	PWM3IP0	0004	
IPC27	00DA	—	ADCP1IP2	ADCP1IP1	ADCP1IP0	—	ADCP0IP2	ADCP0IP1	ADCP0IP0	—	—	—	—	—	—	—	—	—	4400
IPC28	00DC	—	—	—	—	—	—	—	—	—	ADCP3IP2	ADCP3IP1	ADCP3IP0	—	ADCP2IP2	ADCP2IP1	ADCP2IP0	0044	
INTTREG	00E0	—	—	—	—	ILR3	ILR2	ILR1	ILR0	—	VECNUM6	VECNUM5	VECNUM4	VECNUM3	VECNUM2	VECNUM1	VECNUM0	0000	

Legend: x = unknown value on Reset, — = unimplemented, read as '0'. Reset values are shown in hexadecimal.

TABLE 4-9: INTERRUPT CONTROLLER REGISTER MAP FOR dsPIC33FJ16GS502 DEVICES ONLY

File Name	SFR Addr	Bit 15	Bit 14	Bit 13	Bit 12	Bit 11	Bit 10	Bit 9	Bit 8	Bit 7	Bit 6	Bit 5	Bit 4	Bit 3	Bit 2	Bit 1	Bit 0	All Resets
INTCON1	0080	NSTDIS	OVAERR	OVBERR	COVAERR	COVBERR	OVATE	OVBTE	COVTE	SFTACERR	DIV0ERR	—	MATHERR	ADDRERR	STKERR	OSCFAIL	—	0000
INTCON2	0082	ALTVT	DISI	—	—	—	—	—	—	—	—	—	—	—	INT2EP	INT1EP	INT0EP	0000
IFS0	0084	—	—	ADIF	U1TXIF	U1RXIF	SPI1IF	SPI1EIF	T3IF	T2IF	OC2IF	IC2IF	—	T1IF	OC1IF	IC1IF	INT0IF	0000
IFS1	0086	—	—	INT2IF	—	—	—	—	—	—	—	—	INT1IF	CNIF	AC1IF	MI2C1IF	SI2C1IF	0000
IFS3	008A	—	—	—	—	—	—	PSEMIF	—	—	—	—	—	—	—	—	—	0000
IFS4	008C	—	—	—	—	—	—	—	—	—	—	—	—	—	—	U1EIF	—	0000
IFS5	008E	PWM2IF	PWM1IF	—	—	—	—	—	—	—	—	—	—	—	—	—	—	0000
IFS6	0090	ADCP1IF	ADCP0IF	—	—	—	—	AC4IF	AC3IF	AC2IF	—	—	—	—	—	PWM4IF	PWM3IF	0000
IFS7	0092	—	—	—	—	—	—	—	—	—	—	—	ADCP6IF	—	—	ADCP3IF	ADCP2IF	0000
IEC0	0094	—	—	ADIE	U1TXIE	U1RXIE	SPI1IE	SPI1EIE	T3IE	T2IE	OC2IE	IC2IE	—	T1IE	OC1IE	IC1IE	INT0IE	0000
IEC1	0096	—	—	INT2IE	—	—	—	—	—	—	—	—	—	INT1IE	CNIE	AC1IE	MI2C1IE	0000
IEC3	009A	—	—	—	—	—	—	PSEMIE	—	—	—	—	—	—	—	—	—	0000
IEC4	009C	—	—	—	—	—	—	—	—	—	—	—	—	—	—	U1EIE	—	0000
IEC5	009E	PWM2IE	PWM1IE	—	—	—	—	—	—	—	—	—	—	—	—	—	—	0000
IEC6	00A0	ADCP1IE	ADCP0IE	—	—	—	—	AC4IE	AC3IE	AC2IE	—	—	—	—	—	PWM4IE	PWM3IE	0000
IEC7	00A2	—	—	—	—	—	—	—	—	—	—	—	ADCP6IE	—	—	ADCP3IE	ADCP2IE	0000
IPC0	00A4	—	T1IP2	T1IP1	T1IP0	—	OC1IP2	OC1IP1	OC1IP0	—	IC1IP2	IC1IP1	IC1IP0	—	INT0IP2	INT0IP1	INT0IP0	4444
IPC1	00A6	—	T2IP2	T2IP1	T2IP0	—	OC2IP2	OC2IP1	OC2IP0	—	IC2IP2	IC2IP1	IC2IP0	—	—	—	—	4440
IPC2	00A8	—	U1RXIP2	U1RXIP1	U1RXIP0	—	SPI1IP2	SPI1IP1	SPI1IP0	—	SPI1EIP2	SPI1EIP1	SPI1EIP0	—	T3IP2	T3IP1	T3IP0	4444
IPC3	00AA	—	—	—	—	—	—	—	—	—	ADIP2	ADIP1	ADIP0	—	U1TXIP2	U1TXIP1	U1TXIP0	0044
IPC4	00AC	—	CNIP2	CNIP1	CNIP0	—	AC1IP2	AC1IP1	AC1IP0	—	MI2C1IP2	MI2C1IP1	MI2C1IP0	—	SI2C1IP2	SI2C1IP1	SI2C1IP0	4444
IPC5	00AE	—	—	—	—	—	—	—	—	—	—	—	—	—	INT1IP2	INT1IP1	INT1IP0	0004
IPC7	00B2	—	—	—	—	—	—	—	—	—	INT2IP2	INT2IP1	INT2IP0	—	—	—	—	0040
IPC14	00C0	—	—	—	—	—	—	—	—	—	PSEMIP2	PSEMIP1	PSEMIP0	—	—	—	—	0040
IPC16	00C4	—	—	—	—	—	—	—	—	—	U1EIP2	U1EIP1	U1EIP0	—	—	—	—	0040
IPC23	00D2	—	PWM2IP2	PWM2IP1	PWM2IP0	—	PWM1IP2	PWM1IP1	PWM1IP0	—	—	—	—	—	—	—	—	4400
IPC24	00D4	—	—	—	—	—	—	—	—	—	PWM4IP2	PWM4IP1	PWM4IP0	—	PWM3IP2	PWM3IP1	PWM3IP0	0044
IPC25	00D6	—	AC2IP2	AC2IP1	AC2IP0	—	—	—	—	—	—	—	—	—	—	—	—	4000
IPC26	00D8	—	—	—	—	—	—	—	—	—	AC4IP2	AC4IP1	AC4IP0	—	AC3IP2	AC3IP1	AC3IP0	0044
IPC27	00DA	—	ADCP1IP2	ADCP1IP1	ADCP1IP0	—	ADCP0IP2	ADCP0IP1	ADCP0IP0	—	—	—	—	—	—	—	—	4400
IPC28	00DC	—	—	—	—	—	—	—	—	—	ADCP3IP2	ADCP3IP1	ADCP3IP0	—	ADCP2IP2	ADCP2IP1	ADCP2IP0	0044
IPC29	00DE	—	—	—	—	—	—	—	—	—	—	—	—	—	ADCP6IP2	ADCP6IP1	ADCP6IP0	0004
INTTREG	00E0	—	—	—	—	ILR3	ILR2	ILR1	ILR0	—	VECNUM6	VECNUM5	VECNUM4	VECNUM3	VECNUM2	VECNUM1	VECNUM0	0000

Legend: x = unknown value on Reset, — = unimplemented, read as '0'. Reset values are shown in hexadecimal.

TABLE 4-10: INTERRUPT CONTROLLER REGISTER MAP FOR dsPIC33FJ16GS504 DEVICES ONLY

File Name	SFR Addr	Bit 15	Bit 14	Bit 13	Bit 12	Bit 11	Bit 10	Bit 9	Bit 8	Bit 7	Bit 6	Bit 5	Bit 4	Bit 3	Bit 2	Bit 1	Bit 0	All Resets
INTCON1	0080	NSTDIS	OVAERR	OVBERR	COVAERR	COVBERR	OVATE	OVBTE	COVTE	SFTACERR	DIV0ERR	—	MATHERR	ADDRERR	STKERR	OSCFail	—	0000
INTCON2	0082	ALTIPT	DISI	—	—	—	—	—	—	—	—	—	—	—	INT2EP	INT1EP	INT0EP	0000
IFS0	0084	—	—	ADIF	U1TXIF	U1RXIF	SPI1IF	SPI1EIF	T3IF	T2IF	OC2IF	IC2IF	—	T1IF	OC1IF	IC1IF	INT0IF	0000
IFS1	0086	—	—	INT2IF	—	—	—	—	—	—	—	—	INT1IF	CNIF	AC1IF	MI2C1IF	SI2C1IF	0000
IFS3	008A	—	—	—	—	—	—	PSEMIF	—	—	—	—	—	—	—	—	—	0000
IFS4	008C	—	—	—	—	—	—	—	—	—	—	—	—	—	—	U1EIF	—	0000
IFS5	008E	PWM2IF	PWM1IF	—	—	—	—	—	—	—	—	—	—	—	—	—	—	0000
IFS6	0090	ADCP1IF	ADCP0IF	—	—	—	—	AC4IF	AC3IF	AC2IF	—	—	—	—	—	PWM4IF	PWM3IF	0000
IFS7	0092	—	—	—	—	—	—	—	—	—	—	—	ADCP6IF	ADCP5IF	ADCP4IF	ADCP3IF	ADCP2IF	0000
IEC0	0094	—	—	ADIE	U1TXIE	U1RXIE	SPI1IE	SPI1EIE	T3IE	T2IE	OC2IE	IC2IE	—	T1IE	OC1IE	IC1IE	INT0IE	0000
IEC1	0096	—	—	INT2IE	—	—	—	—	—	—	—	—	INT1IE	CNIE	AC1IE	MI2C1IE	SI2C1IE	0000
IEC3	009A	—	—	—	—	—	—	PSEMIE	—	—	—	—	—	—	—	—	—	0000
IEC4	009C	—	—	—	—	—	—	—	—	—	—	—	—	—	—	U1EIE	—	0000
IEC5	009E	PWM2IE	PWM1IE	—	—	—	—	—	—	—	—	—	—	—	—	—	—	0000
IEC6	00A0	ADCP1IE	ADCP0IE	—	—	—	—	AC4IE	AC3IE	AC2IE	—	—	—	—	—	PWM4IE	PWM3IE	0000
IEC7	00A2	—	—	—	—	—	—	—	—	—	—	—	ADCP6IE	ADCP5IE	ADCP4IE	ADCP3IE	ADCP2IE	0000
IPC0	00A4	—	T1IP2	T1IP1	T1IP0	—	OC1IP2	OC1IP1	OC1IP0	—	IC1IP2	IC1IP1	IC1IP0	—	INT0IP2	INT0IP1	INT0IP0	4444
IPC1	00A6	—	T2IP2	T2IP1	T2IP0	—	OC2IP2	OC2IP1	OC2IP0	—	IC2IP2	IC2IP1	IC2IP0	—	—	—	—	4440
IPC2	00A8	—	U1RXIP2	U1RXIP1	U1RXIP0	—	SPI1IP2	SPI1IP1	SPI1IP0	—	SPI1EIP2	SPI1EIP1	SPI1EIP0	—	T3IP2	T3IP1	T3IP0	4444
IPC3	00AA	—	—	—	—	—	—	—	—	—	ADIP2	ADIP1	ADIP0	—	U1TXIP2	U1TXIP1	U1TXIP0	0044
IPC4	00AC	—	CNIP2	CNIP1	CNIP0	—	AC1IP2	AC1IP1	AC1IP0	—	MI2C1IP2	MI2C1IP1	MI2C1IP0	—	SI2C1IP2	SI2C1IP1	SI2C1IP0	4444
IPC5	00AE	—	—	—	—	—	—	—	—	—	—	—	—	—	INT1IP2	INT1IP1	INT1IP0	0004
IPC7	00B2	—	—	—	—	—	—	—	—	—	INT2IP2	INT2IP1	INT2IP0	—	—	—	—	0040
IPC14	00C0	—	—	—	—	—	—	—	—	—	PSEMIP2	PSEMIP1	PSEMIP0	—	—	—	—	0040
IPC16	00C4	—	—	—	—	—	—	—	—	—	U1EIP2	U1EIP1	U1EIP0	—	—	—	—	0040
IPC23	00D2	—	PWM2IP2	PWM2IP1	PWM2IP0	—	PWM1IP2	PWM1IP1	PWM1IP0	—	—	—	—	—	—	—	—	4400
IPC24	00D4	—	—	—	—	—	—	—	—	—	PWM4IP2	PWM4IP1	PWM4IP0	—	PWM3IP2	PWM3IP1	PWM3IP0	0044
IPC25	00D6	—	AC2IP2	AC2IP1	AC2IP0	—	—	—	—	—	—	—	—	—	—	—	—	4000
IPC26	00D8	—	—	—	—	—	—	—	—	—	AC4IP2	AC4IP1	AC4IP0	—	AC3IP2	AC3IP1	AC3IP0	0440
IPC27	00DA	—	ADCP1IP2	ADCP1IP1	ADCP1IP0	—	ADCP0IP2	ADCP0IP1	ADCP0IP0	—	—	—	—	—	—	—	—	4400
IPC28	00DC	—	ADCP5IP2	ADCP5IP1	ADCP5IP0	—	ADCP4IP2	ADCP4IP1	ADCP4IP0	—	ADCP3IP2	ADCP3IP1	ADCP3IP0	—	ADCP2IP2	ADCP2IP1	ADCP2IP0	4444
IPC29	00DE	—	—	—	—	—	—	—	—	—	—	—	—	—	ADCP6IP2	ADCP6IP1	ADCP6IP0	0004
INTTREG	00E0	—	—	—	—	ILR3	ILR2	ILR1	ILR0	—	VECNUM6	VECNUM5	VECNUM4	VECNUM3	VECNUM2	VECNUM1	VECNUM0	0000

Legend: x = unknown value on Reset, — = unimplemented, read as '0'. Reset values are shown in hexadecimal.

TABLE 4-11: TIMER REGISTER MAP FOR dsPIC33FJ06GS101 AND dsPIC33FJ06GSX02

File Name	SFR Addr	Bit 15	Bit 14	Bit 13	Bit 12	Bit 11	Bit 10	Bit 9	Bit 8	Bit 7	Bit 6	Bit 5	Bit 4	Bit 3	Bit 2	Bit 1	Bit 0	All Resets
TMR1	0100	Timer1 Register																0000
PR1	0102	Period Register 1																FFFF
T1CON	0104	TON	—	TSIDL	—	—	—	—	—	—	TGATE	TCKPS1	TCKPS0	—	TSYNC	TCS	—	0000
TMR2	0106	Timer2 Register																0000
PR2	010C	Period Register 2																FFFF
T2CON	0110	TON	—	TSIDL	—	—	—	—	—	—	TGATE	TCKPS1	TCKPS0	—	—	TCS	—	0000

Legend: x = unknown value on Reset, — = unimplemented, read as '0'. Reset values are shown in hexadecimal.

TABLE 4-12: TIMER REGISTER MAP FOR dsPIC33FJ16GSX02 AND dsPIC33FJ16GSX04

File Name	SFR Addr	Bit 15	Bit 14	Bit 13	Bit 12	Bit 11	Bit 10	Bit 9	Bit 8	Bit 7	Bit 6	Bit 5	Bit 4	Bit 3	Bit 2	Bit 1	Bit 0	All Resets
TMR1	0100	Timer1 Register																0000
PR1	0102	Period Register 1																FFFF
T1CON	0104	TON	—	TSIDL	—	—	—	—	—	—	TGATE	TCKPS1	TCKPS0	—	TSYNC	TCS	—	0000
TMR2	0106	Timer2 Register																0000
TMR3HLD	0108	Timer3 Holding Register (for 32-bit timer operations only)																xxxx
TMR3	010A	Timer3 Register																0000
PR2	010C	Period Register 2																FFFF
PR3	010E	Period Register 3																FFFF
T2CON	0110	TON	—	TSIDL	—	—	—	—	—	—	TGATE	TCKPS1	TCKPS0	T32	—	TCS	—	0000
T3CON	0112	TON	—	TSIDL	—	—	—	—	—	—	TGATE	TCKPS1	TCKPS0	—	—	TCS	—	0000

Legend: x = unknown value on Reset, — = unimplemented, read as '0'. Reset values are shown in hexadecimal.

TABLE 4-13: INPUT CAPTURE REGISTER MAP FOR dsPIC33FJ06GS202

File Name	SFR Addr	Bit 15	Bit 14	Bit 13	Bit 12	Bit 11	Bit 10	Bit 9	Bit 8	Bit 7	Bit 6	Bit 5	Bit 4	Bit 3	Bit 2	Bit 1	Bit 0	All Resets
IC1BUF	0140	Input Capture 1 Register																xxxx
IC1CON	0142	—	—	ICSIDL	—	—	—	—	—	ICTMR	ICI1	ICI0	ICOV	ICBNE	ICM2	ICM1	ICM0	0000

Legend: x = unknown value on Reset, — = unimplemented, read as '0'. Reset values are shown in hexadecimal.

TABLE 4-14: INPUT CAPTURE REGISTER MAP FOR dsPIC33FJ16GSX02 AND dsPIC33FJ16GSX04

File Name	SFR Addr	Bit 15	Bit 14	Bit 13	Bit 12	Bit 11	Bit 10	Bit 9	Bit 8	Bit 7	Bit 6	Bit 5	Bit 4	Bit 3	Bit 2	Bit 1	Bit 0	All Resets
IC1BUF	0140	Input Capture 1 Register																xxxx
IC1CON	0142	—	—	ICSIDL	—	—	—	—	—	ICTMR	IC1	IC0	ICOV	ICBNE	ICM2	ICM1	ICM0	0000
IC2BUF	0144	Input Capture 2 Register																xxxx
IC2CON	0146	—	—	ICSIDL	—	—	—	—	—	ICTMR	IC1	IC0	ICOV	ICBNE	ICM2	ICM1	ICM0	0000

Legend: x = unknown value on Reset, — = unimplemented, read as '0'. Reset values are shown in hexadecimal.

TABLE 4-15: OUTPUT COMPARE REGISTER MAP FOR dsPIC33FJ06GS101 AND dsPIC33FJ06GSX02

File Name	SFR Addr	Bit 15	Bit 14	Bit 13	Bit 12	Bit 11	Bit 10	Bit 9	Bit 8	Bit 7	Bit 6	Bit 5	Bit 4	Bit 3	Bit 2	Bit 1	Bit 0	All Resets
OC1RS	0180	Output Compare 1 Secondary Register																xxxx
OC1R	0182	Output Compare 1 Register																xxxx
OC1CON	0184	—	—	OCSIDL	—	—	—	—	—	—	—	—	OCFLT	OCTSEL	OCM2	OCM1	OCM0	0000

Legend: x = unknown value on Reset, — = unimplemented, read as '0'. Reset values are shown in hexadecimal.

TABLE 4-16: OUTPUT COMPARE REGISTER MAP FOR dsPIC33FJ16GSX02 AND dsPIC33FJ06GSX04

File Name	SFR Addr	Bit 15	Bit 14	Bit 13	Bit 12	Bit 11	Bit 10	Bit 9	Bit 8	Bit 7	Bit 6	Bit 5	Bit 4	Bit 3	Bit 2	Bit 1	Bit 0	All Resets
OC1RS	0180	Output Compare 1 Secondary Register																xxxx
OC1R	0182	Output Compare 1 Register																xxxx
OC1CON	0184	—	—	OCSIDL	—	—	—	—	—	—	—	—	OCFLT	OCTSEL	OCM2	OCM1	OCM0	0000
OC2RS	0186	Output Compare 2 Secondary Register																xxxx
OC2R	0188	Output Compare 2 Register																xxxxx
OC2CON	018A	—	—	OCSIDL	—	—	—	—	—	—	—	—	OCFLT	OCTSEL	OCM2	OCM1	OCM0	0000

Legend: x = unknown value on Reset, — = unimplemented, read as '0'. Reset values are shown in hexadecimal.

TABLE 4-17: HIGH-SPEED PWM REGISTER MAP

File Name	SFR Addr	Bit 15	Bit 14	Bit 13	Bit 12	Bit 11	Bit 10	Bit 9	Bit 8	Bit 7	Bit 6	Bit 5	Bit 4	Bit 3	Bit 2	Bit 1	Bit 0	All Resets
PTCON	0400	PTEN	—	PTSIDL	SESTAT	SEIEN	EIPU	SYNCPOL	SYNCOEN	SYNCEN	—	SYNCSRC1	SYNCSRC0	SEVTPS3	SEVTPS2	SEVTPS1	SEVTPS0	0000
PTCON2	0402	—	—	—	—	—	—	—	—	—	—	—	—	—	PCLKDIV2	PCLKDIV1	PCLKDIV0	0000
PTPER	0404	PTPER<15:0>																FFF8
SEVTCMP	0406	SEVTCMP<15:3>																0000
MDC	040A	MDC<15:0>																0000

Legend: x = unknown value on Reset, — = unimplemented, read as '0'. Reset values are shown in hexadecimal.

TABLE 4-18: HIGH-SPEED PWM GENERATOR 1 REGISTER MAP

File Name	SFR Addr	Bit 15	Bit 14	Bit 13	Bit 12	Bit 11	Bit 10	Bit 9	Bit 8	Bit 7	Bit 6	Bit 5	Bit 4	Bit 3	Bit 2	Bit 1	Bit 0	All Resets
PWMCON1	0420	FLTSTAT	CLSTAT	TRGSTAT	FLTIEN	CLIEN	TRGIEN	ITB	MDCS	DTC1	DTC0	—	—	—	CAM	XPRES	IUE	0000
IOCON1	0422	PENH	PENL	POLH	POLL	PMOD1	PMOD0	OVRENH	OVRENL	OVRDAT1	OVRDAT0	FLTDAT1	FLTDAT0	CLDAT1	CLDAT0	SWAP	OSYNC	0000
FCLCON1	0424	IFLTMOD	CLSRC4	CLSRC3	CLSRC2	CLSRC1	CLSRC0	CLPOL	CLMOD	FLTSRC4	FLTSRC3	FLTSRC2	FLTSRC1	FLTSRC0	FLTPOL	FLTMOD1	FLTMOD0	0000
PDC1	0426	PDC1<15:0>																0000
PHASE1	0428	PHASE1<15:0>																0000
DTR1	042A	—	—	DTR1<13:0>														0000
ALTDTR1	042C	—	—	ALTDTR1<13:0>														0000
SDC1	042E	SDC1<15:0>																0000
SPHASE1	0430	SPHASE1<15:0>																0000
TRIG1	0432	TRGCMP<15:3>													—	—	—	0000
TRGCON1	0434	TRGDIV3	TRGDIV2	TRGDIV1	TRGDIV0	—	—	—	—	DTM	—	TRGSTR5	TRGSTR4	TRGSTR3	TRGSTR2	TRGSTR1	TRGSTR0	0000
STRIG1	0436	STRGCMP<15:3>													—	—	—	0000
PWMCAP1	0438	PWMCAP1<15:3>																0000
LEBCON1	043A	PHR	PHF	PLR	PLF	FLTLEBEN	CLLEBEN	LEB6	LEB5	LEB4	LEB3	LEB2	LEB1	LEB0	—	—	—	0000

Legend: x = unknown value on Reset, — = unimplemented, read as '0'. Reset values are shown in hexadecimal.

TABLE 4-19: HIGH-SPEED PWM GENERATOR 2 REGISTER MAP FOR dsPIC33FJ06GS102/202 AND dsPIC33FJ16GSX02/X04 DEVICES ONLY

File Name	SFR Addr	Bit 15	Bit 14	Bit 13	Bit 12	Bit 11	Bit 10	Bit 9	Bit 8	Bit 7	Bit 6	Bit 5	Bit 4	Bit 3	Bit 2	Bit 1	Bit 0	All Resets
PWMCON2	0440	FLTSTAT	CLSTAT	TRGSTAT	FLTIEN	CLIEN	TRGIEN	ITB	MDCS	DTC1	DTC0	—	—	—	CAM	XPRES	IUE	0000
IOCON2	0442	PENH	PENL	POLH	POLL	PMOD1	PMOD0	OVRENH	OVRENL	OVRDAT1	OVRDAT0	FLTDAT1	FLTDAT0	CLDAT1	CLDAT0	SWAP	OSYNC	0000
FCLCON2	0444	IFLTMOD	CLSRC4	CLSRC3	CLSRC2	CLSRC1	CLSRC0	CLPOL	CLMOD	FLTSRC4	FLTSRC3	FLTSRC2	FLTSRC1	FLTSRC0	FLTPOL	FLTMOD1	FLTMOD0	0000
PDC2	0446	PDC2<15:0>																0000
PHASE2	0448	PHASE2<15:0>																0000
DTR2	044A	—	—	DTR2<13:0>														0000
ALTDTR2	044C	—	—	ALTDTR2<13:0>														0000
SDC2	044E	SDC2<15:0>																0000
SPHASE2	0450	SPHASE2<15:0>																0000
TRIG2	0452	TRGCMP<15:3>													—	—	—	0000
TRGCON2	0454	TRGDIV3	TRGDIV2	TRGDIV1	TRGDIV0	—	—	—	—	DTM	—	TRGSTR5	TRGSTR4	TRGSTR3	TRGSTR2	TRGSTR1	TRGSTR0	0000
STRIG2	0456	STRGCMP<15:3>													—	—	—	0000
PWMCAP2	0458	PWMCAP2<15:3>																0000
LEBCON2	045A	PHR	PHF	PLR	PLF	FLTLEBEN	CLLEBEN	LEB6	LEB5	LEB4	LEB3	LEB2	LEB1	LEB0	—	—	—	0000

Legend: x = unknown value on Reset, — = unimplemented, read as '0'. Reset values are shown in hexadecimal.

TABLE 4-20: HIGH-SPEED PWM GENERATOR 3 REGISTER MAP FOR dsPIC33FJ16GSX02/X04 DEVICES ONLY

File Name	SFR Addr	Bit 15	Bit 14	Bit 13	Bit 12	Bit 11	Bit 10	Bit 9	Bit 8	Bit 7	Bit 6	Bit 5	Bit 4	Bit 3	Bit 2	Bit 1	Bit 0	All Resets
PWMCON3	0460	FLTSTAT	CLSTAT	TRGSTAT	FLTIEN	CLIEN	TRGIEN	ITB	MDCS	DTC1	DTC0	—	—	—	CAM	XPRES	IUE	0000
IOCON3	0462	PENH	PENL	POLH	POLL	PMOD1	PMOD0	OVRENH	OVRENL	OVRDAT1	OVRDAT0	FLTDAT1	FLTDAT0	CLDAT1	CLDAT0	SWAP	OSYNC	0000
FCLCON3	0464	IFLTMOD	CLSRC4	CLSRC3	CLSRC2	CLSRC1	CLSRC0	CLPOL	CLMOD	FLTSRC4	FLTSRC3	FLTSRC2	FLTSRC1	FLTSRC0	FLTPOL	FLTMOD1	FLTMOD0	0000
PDC3	0466	PDC3<15:0>																0000
PHASE3	0468	PHASE3<15:0>																0000
DTR3	046C	—	—	DTR3<13:0>														0000
ALTDTR3	046C	—	—	ALTDTR3<13:0>														0000
SDC3	046E	SDC3<15:0>																0000
SPHASE3	0470	SPHASE3<15:0>																0000
TRIG3	0472	TRGCMP<15:3>													—	—	—	0000
TRGCON3	0474	TRGDIV3	TRGDIV2	TRGDIV1	TRGDIV0	—	—	—	—	DTM	—	TRGSTR5	TRGSTR4	TRGSTR3	TRGSTR2	TRGSTR1	TRGSTR0	0000
STRIG3	0476	STRGCMP<15:3>													—	—	—	0000
PWMCAP3	0478	PWMCAP3<15:3>													—	—	—	0000
LEBCON3	047A	PHR	PHF	PLR	PLF	FLTLEBEN	CLLEBEN	LEB6	LEB5	LEB4	LEB3	LEB2	LEB1	LEB0	—	—	—	0000

Legend: x = unknown value on Reset, — = unimplemented, read as '0'. Reset values are shown in hexadecimal.

TABLE 4-21: HIGH-SPEED PWM GENERATOR 4 REGISTER MAP FOR dsPIC33FJ06GS101 AND dsPIC33FJ16GS50X DEVICES ONLY

File Name	SFR Addr	Bit 15	Bit 14	Bit 13	Bit 12	Bit 11	Bit 10	Bit 9	Bit 8	Bit 7	Bit 6	Bit 5	Bit 4	Bit 3	Bit 2	Bit 1	Bit 0	All Resets
PWMCON4	0480	FLTSTAT	CLSTAT	TRGSTAT	FLTIEN	CLIEN	TRGIEN	ITB	MDCS	DTC1	DTC0	—	—	—	CAM	XPRES	IUE	0000
IOCON4	0482	PENH	PENL	POLH	POLL	PMOD1	PMOD0	OVRENH	OVRENL	OVRDAT1	OVRDAT0	FLTDAT1	FLTDAT0	CLDAT1	CLDAT0	SWAP	OSYNC	0000
FCLCON4	0484	IFLTMOD	CLSRC4	CLSRC3	CLSRC2	CLSRC1	CLSRC0	CLPOL	CLMOD	FLTSRC4	FLTSRC3	FLTSRC2	FLTSRC1	FLTSRC0	FLTPOL	FLTMOD1	FLTMOD0	0000
PDC4	0486	PDC4<15:0>																0000
PHASE4	0488	PHASE4<15:0>																0000
DTR4	048A	—	—	DTR4<13:0>														0000
ALTDTR4	048A	—	—	ALTDTR4<13:0>														0000
SDC4	048E	SDC4<15:0>																0000
SPHASE4	0490	SPHASE4<15:0>																0000
TRIG4	0492	TRGCMP<15:3>													—	—	—	0000
TRGCON4	0494	TRGDIV3	TRGDIV2	TRGDIV1	TRGDIV0	—	—	—	—	DTM	—	TRGSTR5	TRGSTR4	TRGSTR3	TRGSTR2	TRGSTR1	TRGSTR0	0000
STRIG4	0496	STRGCMP<15:3>													—	—	—	0000
PWMCAP4	0498	PWMCAP4<15:3>													—	—	—	0000
LEBCON4	049A	PHR	PHF	PLR	PLF	FLTLEBEN	CLLEBEN	LEB6	LEB5	LEB4	LEB3	LEB2	LEB1	LEB0	—	—	—	0000

Legend: x = unknown value on Reset, — = unimplemented, read as '0'. Reset values are shown in hexadecimal.

TABLE 4-22: I2C1 REGISTER MAP

File Name	SFR Addr	Bit 15	Bit 14	Bit 13	Bit 12	Bit 11	Bit 10	Bit 9	Bit 8	Bit 7	Bit 6	Bit 5	Bit 4	Bit 3	Bit 2	Bit 1	Bit 0	All Resets	
I2C1RCV	0200	—	—	—	—	—	—	—	—	I2C1 Receive Register									0000
I2C1TRN	0202	—	—	—	—	—	—	—	—	I2C1 Transmit Register									00FF
I2C1BRG	0204	—	—	—	—	—	—	—	Baud Rate Generator Register										0000
I2C1CON	0206	I2CEN	—	I2CSIDL	SCLREL	IPMIEN	A10M	DISSLW	SMEN	GCEN	STREN	ACKDT	ACKEN	RCEN	PEN	RSEN	SEN	1000	
I2C1STAT	0208	ACKSTAT	TRSTAT	—	—	—	BCL	GCSTAT	ADD10	IWCOL	I2COV	D_A	P	S	R_W	RBF	TBF	0000	
I2C1ADD	020A	—	—	—	—	—	—	I2C1 Address Register										0000	
I2C1MSK	020C	—	—	—	—	—	—	AMSK<9:0>										0000	

Legend: x = unknown value on Reset, — = unimplemented, read as '0'. Reset values are shown in hexadecimal.

TABLE 4-23: UART1 REGISTER MAP

File Name	SFR Addr	Bit 15	Bit 14	Bit 13	Bit 12	Bit 11	Bit 10	Bit 9	Bit 8	Bit 7	Bit 6	Bit 5	Bit 4	Bit 3	Bit 2	Bit 1	Bit 0	All Resets
U1MODE	0220	UARTEN	—	USIDL	IREN	RTSMD	—	UEN1	UEN0	WAKE	LPBACK	ABAUD	URXINV	BRGH	PDSEL1	PDSEL0	STSEL	0000
U1STA	0222	UTXISEL1	UTXINV	UTXISEL0	—	UTXBRK	UTXEN	UTXBF	TRMT	URXISEL1	URXISEL0	ADDEN	RIDL	PERR	FERR	OERR	URXDA	0110
U1TXREG	0224	—	—	—	—	—	—	—	UART1 Transmit Register									xxxxx
U1RXREG	0226	—	—	—	—	—	—	—	UART1 Receive Register									0000
U1BRG	0228	Baud Rate Generator Prescaler																0000

Legend: x = unknown value on Reset, — = unimplemented, read as '0'. Reset values are shown in hexadecimal.

TABLE 4-24: SPI1 REGISTER MAP

File Name	SFR Addr	Bit 15	Bit 14	Bit 13	Bit 12	Bit 11	Bit 10	Bit 9	Bit 8	Bit 7	Bit 6	Bit 5	Bit 4	Bit 3	Bit 2	Bit 1	Bit 0	All Resets
SPI1STAT	0240	SPIEN	—	SPIIDL	—	—	—	—	—	—	SPIROV	—	—	—	—	SPITBF	SPIRBF	0000
SPI1CON1	0242	—	—	—	DISSCK	DISSDO	MODE16	SMP	CKE	SSEN	CKP	MSTEN	SPRE2	SPRE1	SPRE0	PPRE1	PPRE0	0000
SPI1CON2	0244	FRMEN	SPIFSD	FRMPOL	—	—	—	—	—	—	—	—	—	—	—	FRMDLY	—	0000
SPI1BUF	0248	SPI1 Transmit and Receive Buffer Register																0000

Legend: x = unknown value on Reset, — = unimplemented, read as '0'. Reset values are shown in hexadecimal.

TABLE 4-25: HIGH-SPEED 10-BIT ADC REGISTER MAP FOR dsPIC33FJ06GS101 DEVICES ONLY

File Name	SFR Addr	Bit 15	Bit 14	Bit 13	Bit 12	Bit 11	Bit 10	Bit 9	Bit 8	Bit 7	Bit 6	Bit 5	Bit 4	Bit 3	Bit 2	Bit 1	Bit 0	All Resets
ADCON	0300	ADON	—	ADSIDL	SLOWCLK	—	GSWTRG	—	FORM	EIE	ORDER	SEQSAMP	ASYNCSAMP	—	ADCS2	ADCS1	ADCS0	0003
ADPCFG	0302	—	—	—	—	—	—	—	—	PCFG7	PCFG6	—	—	PCFG3	PCFG2	PCFG1	PCFG0	0000
ADSTAT	0306	—	—	—	—	—	—	—	—	—	—	—	—	P3RDY	—	P1RDY	P0RDY	0000
ADBASE	0308	ADBASE<15:1>															—	0000
ADCPC0	030A	IRQEN1	PEND1	SWTRG1	TRGSRC14	TRGSRC13	TRGSRC12	TRGSRC11	TRGSRC10	IRQEN0	PEND0	SWTRG0	TRGSRC04	TRGSRC03	TRGSRC02	TRGSRC01	TRGSRC00	0000
ADCPC1	030C	IRQEN3	PEND3	SWTRG3	TRGSRC34	TRGSRC33	TRGSRC32	TRGSRC31	TRGSRC30	—	—	—	—	—	—	—	—	0000
ADCBUF0	0320	ADC Data Buffer 0															xxxx	
ADCBUF1	0322	ADC Data Buffer 1															xxxx	
ADCBUF2	0324	ADC Data Buffer 2															xxxx	
ADCBUF3	0326	ADC Data Buffer 3															xxxx	
ADCBUF6	032C	ADC Data Buffer 6															xxxx	
ADCBUF7	032E	ADC Data Buffer 7															xxxx	

Legend: x = unknown value on Reset, — = unimplemented, read as '0'. Reset values are shown in hexadecimal.

TABLE 4-26: HIGH-SPEED 10-BIT ADC REGISTER MAP FOR dsPIC33FJ06GS102 DEVICES ONLY

File Name	SFR Addr	Bit 15	Bit 14	Bit 13	Bit 12	Bit 11	Bit 10	Bit 9	Bit 8	Bit 7	Bit 6	Bit 5	Bit 4	Bit 3	Bit 2	Bit 1	Bit 0	All Resets
ADCON	0300	ADON	—	ADSIDL	SLOWCLK	—	GSWTRG	—	FORM	EIE	ORDER	SEQSAMP	ASYNCSAMP	—	ADCS2	ADCS1	ADCS0	0003
ADPCFG	0302	—	—	—	—	—	—	—	—	—	—	PCFG5	PCFG4	PCFG3	PCFG2	PCFG1	PCFG0	0000
ADSTAT	0306	—	—	—	—	—	—	—	—	—	—	—	—	—	P2RDY	P1RDY	P0RDY	0000
ADBASE	0308	ADBASE<15:1>															—	0000
ADCPC0	030A	IRQEN1	PEND1	SWTRG1	TRGSRC14	TRGSRC13	TRGSRC12	TRGSRC11	TRGSRC10	IRQEN0	PEND0	SWTRG0	TRGSRC04	TRGSRC03	TRGSRC02	TRGSRC01	TRGSRC00	0000
ADCPC1	030C	—	—	—	—	—	—	—	—	IRQEN2	PEND2	SWTRG2	TRGSRC24	TRGSRC23	TRGSRC22	TRGSRC21	TRGSRC20	0000
ADCBUF0	0320	ADC Data Buffer 0															xxxx	
ADCBUF1	0322	ADC Data Buffer 1															xxxx	
ADCBUF2	0324	ADC Data Buffer 2															xxxx	
ADCBUF3	0326	ADC Data Buffer 3															xxxx	
ADCBUF4	0328	ADC Data Buffer 4															xxxx	
ADCBUF5	032A	ADC Data Buffer 5															xxxx	

Legend: x = unknown value on Reset, — = unimplemented, read as '0'. Reset values are shown in hexadecimal.

TABLE 4-27: HIGH-SPEED 10-BIT ADC REGISTER MAP FOR dsPIC33FJ06GS202 DEVICES ONLY

File Name	SFR Addr	Bit 15	Bit 14	Bit 13	Bit 12	Bit 11	Bit 10	Bit 9	Bit 8	Bit 7	Bit 6	Bit 5	Bit 4	Bit 3	Bit 2	Bit 1	Bit 0	All Resets	
ADCON	0300	ADON	—	ADSIDL	SLOWCLK	—	GSWTRG	—	FORM	EIE	ORDER	SEQSAMP	ASYNCAMP	—	ADCS2	ADCS1	ADCS0	0003	
ADPCFG	0302	—	—	—	—	—	—	—	—	—	—	PCFG5	PCFG4	PCFG3	PCFG2	PCFG1	PCFG0	0000	
ADSTAT	0306	—	—	—	—	—	—	—	—	—	P6RDY	—	—	—	P2RDY	P1RDY	P0RDY	0000	
ADBASE	0308	ADBASE<15:1>																—	0000
ADCPC0	030A	IRQEN1	PEND1	SWTRG1	TRGSRC14	TRGSRC13	TRGSRC12	TRGSRC11	TRGSRC10	IRQEN0	PEND0	SWTRG0	TRGSRC04	TRGSRC03	TRGSRC02	TRGSRC01	TRGSRC00	0000	
ADCPC1	030C	—	—	—	—	—	—	—	—	IRQEN2	PEND2	SWTRG2	TRGSRC24	TRGSRC23	TRGSRC22	TRGSRC21	TRGSRC20	0000	
ADCPC3	0310	—	—	—	—	—	—	—	—	IRQEN6	PEND6	SWTRG6	TRGSRC64	TRGSRC63	TRGSRC62	TRGSRC61	TRGSRC60	0000	
ADCBUF0	0320	ADC Data Buffer 0																xxxx	
ADCBUF1	0322	ADC Data Buffer 1																xxxx	
ADCBUF2	0324	ADC Data Buffer 2																xxxx	
ADCBUF3	0326	ADC Data Buffer 3																xxxx	
ADCBUF4	0328	ADC Data Buffer 4																xxxx	
ADCBUF5	032A	ADC Data Buffer 5																xxxx	
ADCBUF12	0338	ADC Data Buffer 12																xxxx	
ADCBUF13	033A	ADC Data Buffer 13																xxxx	

Legend: x = unknown value on Reset, — = unimplemented, read as '0'. Reset values are shown in hexadecimal.

TABLE 4-28: HIGH-SPEED 10-BIT ADC REGISTER MAP FOR dsPIC33FJ16GS402/404 DEVICES ONLY

File Name	SFR Addr	Bit 15	Bit 14	Bit 13	Bit 12	Bit 11	Bit 10	Bit 9	Bit 8	Bit 7	Bit 6	Bit 5	Bit 4	Bit 3	Bit 2	Bit 1	Bit 0	All Resets	
ADCON	0300	ADON	—	ADSIDL	SLOWCLK	—	GSWTRG	—	FORM	EIE	ORDER	SEQSAMP	ASYNCAMP	—	ADCS2	ADCS1	ADCS0	0003	
ADPCFG	0302	—	—	—	—	—	—	—	—	PCFG7	PCFG6	PCFG5	PCFG4	PCFG3	PCFG2	PCFG1	PCFG0	0000	
ADSTAT	0306	—	—	—	—	—	—	—	—	—	—	—	—	P3RDY	P2RDY	P1RDY	P0RDY	0000	
ADBASE	0308	ADBASE<15:1>																—	0000
ADCPC0	030A	IRQEN1	PEND1	SWTRG1	TRGSRC14	TRGSRC13	TRGSRC12	TRGSRC11	TRGSRC10	IRQEN0	PEND0	SWTRG0	TRGSRC04	TRGSRC03	TRGSRC02	TRGSRC01	TRGSRC00	0000	
ADCPC1	030C	IRQEN3	PEND3	SWTRG3	TRGSRC34	TRGSRC33	TRGSRC32	TRGSRC31	TRGSRC30	IRQEN2	PEND2	SWTRG2	TRGSRC24	TRGSRC23	TRGSRC22	TRGSRC21	TRGSRC20	0000	
ADCBUF0	0320	ADC Data Buffer 0																xxxx	
ADCBUF1	0322	ADC Data Buffer 1																xxxx	
ADCBUF2	0324	ADC Data Buffer 2																xxxx	
ADCBUF3	0326	ADC Data Buffer 3																xxxx	
ADCBUF4	0328	ADC Data Buffer 4																xxxx	
ADCBUF5	032A	ADC Data Buffer 5																xxxx	
ADCBUF6	032C	ADC Data Buffer 6																xxxx	
ADCBUF7	032E	ADC Data Buffer 7																xxxx	

Legend: x = unknown value on Reset, — = unimplemented, read as '0'. Reset values are shown in hexadecimal.

TABLE 4-29: HIGH-SPEED 10-BIT ADC REGISTER MAP FOR dsPIC33FJ16GS502 DEVICES ONLY

File Name	SFR Addr	Bit 15	Bit 14	Bit 13	Bit 12	Bit 11	Bit 10	Bit 9	Bit 8	Bit 7	Bit 6	Bit 5	Bit 4	Bit 3	Bit 2	Bit 1	Bit 0	All Resets	
ADCON	0300	ADON	—	ADSIDL	SLOWCLK	—	GSWTRG	—	FORM	EIE	ORDER	SEQSAMP	ASYNCAMP	—	ADCS2	ADCS1	ADCS0	0003	
ADPCFG	0302	—	—	—	—	—	—	—	—	PCFG7	PCFG6	PCFG5	PCFG4	PCFG3	PCFG2	PCFG1	PCFG0	0000	
ADSTAT	0306	—	—	—	—	—	—	—	—	—	P6RDY	—	—	P3RDY	P2RDY	P1RDY	P0RDY	0000	
ADBASE	0308	ADBASE<15:1>																—	0000
ADCPC0	030A	IRQEN1	PEND1	SWTRG1	TRGSRC14	TRGSRC13	TRGSRC12	TRGSRC11	TRGSRC10	IRQEN0	PEND0	SWTRG0	TRGSRC04	TRGSRC03	TRGSRC02	TRGSRC01	TRGSRC00	0000	
ADCPC1	030C	IRQEN3	PEND3	SWTRG3	TRGSRC34	TRGSRC33	TRGSRC32	TRGSRC31	TRGSRC30	IRQEN2	PEND2	SWTRG2	TRGSRC24	TRGSRC23	TRGSRC22	TRGSRC21	TRGSRC20	0000	
ADCPC3	0310	—	—	—	—	—	—	—	—	IRQEN6	PEND6	SWTRG6	TRGSRC64	TRGSRC63	TRGSRC62	TRGSRC61	TRGSRC60	0000	
ADCBUF0	0320	ADC Data Buffer 0																xxxx	
ADCBUF1	0322	ADC Data Buffer 1																xxxx	
ADCBUF2	0324	ADC Data Buffer 2																xxxx	
ADCBUF3	0326	ADC Data Buffer 3																xxxx	
ADCBUF4	0328	ADC Data Buffer 4																xxxx	
ADCBUF5	032A	ADC Data Buffer 5																xxxx	
ADCBUF6	032C	ADC Data Buffer 6																xxxx	
ADCBUF7	032E	ADC Data Buffer 7																xxxx	
ADCBUF12	0338	ADC Data Buffer 12																xxxx	
ADCBUF13	033A	ADC Data Buffer 13																xxxx	

Legend: x = unknown value on Reset, — = unimplemented, read as '0'. Reset values are shown in hexadecimal.

TABLE 4-30: HIGH-SPEED 10-BIT ADC REGISTER MAP FOR dsPIC33FJ16GS504 DEVICES ONLY

File Name	SFR Addr	Bit 15	Bit 14	Bit 13	Bit 12	Bit 11	Bit 10	Bit 9	Bit 8	Bit 7	Bit 6	Bit 5	Bit 4	Bit 3	Bit 2	Bit 1	Bit 0	All Resets	
ADCON	0300	ADON	—	ADSIDL	SLOWCLK	—	GSWTRG	—	FORM	EIE	ORDER	SEQSAMP	ASYNCSAMP	—	ADCS2	ADCS1	ADCS0	0003	
ADPCFG	0302	—	—	—	—	PCFG11	PCFG10	PCFG9	PCFG8	PCFG7	PCFG6	PCFG5	PCFG4	PCFG3	PCFG2	PCFG1	PCFG0	0000	
ADSTAT	0306	—	—	—	—	—	—	—	—	—	P6RDY	P5RDY	P4RDY	P3RDY	P2RDY	P1RDY	P0RDY	0000	
ADBASE	0308	ADBASE<15:1>																—	0000
ADCPC0	030A	IRQEN1	PEND1	SWTRG1	TRGSRC14	TRGSRC13	TRGSRC12	TRGSRC11	TRGSRC10	IRQEN0	PEND0	SWTRG0	TRGSRC04	TRGSRC03	TRGSRC02	TRGSRC01	TRGSRC00	0000	
ADCPC1	030C	IRQEN3	PEND3	SWTRG3	TRGSRC34	TRGSRC33	TRGSRC32	TRGSRC31	TRGSRC30	IRQEN2	PEND2	SWTRG2	TRGSRC24	TRGSRC23	TRGSRC22	TRGSRC21	TRGSRC20	0000	
ADCPC2	030E	IRQEN5	PEND5	SWTRG5	TRGSRC54	TRGSRC53	TRGSRC52	TRGSRC51	TRGSRC50	IRQEN4	PEND4	SWTRG4	TRGSRC44	TRGSRC43	TRGSRC42	TRGSRC41	TRGSRC40	0000	
ADCPC3	0310	—	—	—	—	—	—	—	—	IRQEN6	PEND6	SWTRG6	TRGSRC64	TRGSRC63	TRGSRC62	TRGSRC61	TRGSRC60	0000	
ADCBUF0	0320	ADC Data Buffer 0																xxxx	
ADCBUF1	0322	ADC Data Buffer 1																xxxx	
ADCBUF2	0324	ADC Data Buffer 2																xxxx	
ADCBUF3	0326	ADC Data Buffer 3																xxxx	
ADCBUF4	0328	ADC Data Buffer 4																xxxx	
ADCBUF5	032A	ADC Data Buffer 5																xxxx	
ADCBUF6	032C	ADC Data Buffer 6																xxxx	
ADCBUF7	032E	ADC Data Buffer 7																xxxx	
ADCBUF8	0330	ADC Data Buffer 8																xxxx	
ADCBUF9	0332	ADC Data Buffer 9																xxxx	
ADCBUF10	0334	ADC Data Buffer 10																xxxx	
ADCBUF11	0336	ADC Data Buffer 11																xxxx	
ADCBUF12	0338	ADC Data Buffer 12																xxxx	
ADCBUF13	033A	ADC Data Buffer 13																xxxx	

Legend: x = unknown value on Reset, — = unimplemented, read as '0'. Reset values are shown in hexadecimal.

TABLE 4-31: ANALOG COMPARATOR CONTROL REGISTER MAP FOR dsPIC33FJ06GS202 DEVICES ONLY

File Name	ADR	Bit 15	Bit 14	Bit 13	Bit 12	Bit 11	Bit 10	Bit 9	Bit 8	Bit 7	Bit 6	Bit 5	Bit 4	Bit 3	Bit 2	Bit 1	Bit 0	All Resets
CMPCON1	0540	CMPON	—	CMPSIDL	—	—	—	—	DACOE	INSEL1	INSEL0	EXTREF	—	CMPSTAT	—	CMPPOL	RANGE	0000
CMPDAC1	0542	—	—	—	—	—	—	CMREF<9:0>										0000
CMPCON2	0544	CMPON	—	CMPSIDL	—	—	—	—	DACOE	INSEL1	INSEL0	EXTREF	—	CMPSTAT	—	CMPPOL	RANGE	0000
CMPDAC2	0546	—	—	—	—	—	—	CMREF<9:0>										0000

TABLE 4-32: ANALOG COMPARATOR CONTROL REGISTER MAP dsPIC33FJ16GS502/504 DEVICES ONLY

File Name	SFR Addr	Bit 15	Bit 14	Bit 13	Bit 12	Bit 11	Bit 10	Bit 9	Bit 8	Bit 7	Bit 6	Bit 5	Bit 4	Bit 3	Bit 2	Bit 1	Bit 0	All Resets
CMPCON1	0540	CMPON	—	CMPSIDL	—	—	—	—	DACOE	INSEL1	INSEL0	EXTREF	—	CMPSTAT	—	CMPPOL	RANGE	0000
CMPDAC1	0542	—	—	—	—	—	—	CMREF<9:0>										0000
CMPCON2	0544	CMPON	—	CMPSIDL	—	—	—	—	DACOE	INSEL1	INSEL0	EXTREF	—	CMPSTAT	—	CMPPOL	RANGE	0000
CMPDAC2	0546	—	—	—	—	—	—	CMREF<9:0>										0000
CMPCON3	0548	CMPON	—	CMPSIDL	—	—	—	—	DACOE	INSEL1	INSEL0	EXTREF	—	CMPSTAT	—	CMPPOL	RANGE	0000
CMPDAC3	054A	—	—	—	—	—	—	CMREF<9:0>										0000
CMPCON4	054C	CMPON	—	CMPSIDL	—	—	—	—	DACOE	INSEL1	INSEL0	EXTREF	—	CMPSTAT	—	CMPPOL	RANGE	0000
CMPDAC4	054E	—	—	—	—	—	—	CMREF<9:0>										0000

TABLE 4-33: PERIPHERAL PIN SELECT INPUT REGISTER MAP

File Name	SFR Addr	Bit 15	Bit 14	Bit 13	Bit 12	Bit 11	Bit 10	Bit 9	Bit 8	Bit 7	Bit 6	Bit 5	Bit 4	Bit 3	Bit 2	Bit 1	Bit 0	All Resets
RPINR0	0680	—	—	INT1R5	INT1R4	INT1R3	INT1R2	INT1R1	INT1R0	—	—	—	—	—	—	—	—	3F00
RPINR1	0682	—	—	—	—	—	—	—	—	—	—	INT2R5	INT2R4	INT2R3	INT2R2	INT2R1	INT2R0	003F
RPINR2	0684	—	—	T1CKR5	T1CKR4	T1CKR3	T1CKR2	T1CKR1	T1CKR0	—	—	—	—	—	—	—	—	0000
RPINR3	0686	—	—	T3CKR5	T3CKR4	T3CKR3	T3CKR2	T3CKR1	T3CKR0	—	—	T2CKR5	T2CKR4	T2CKR3	T2CKR2	T2CKR1	T2CKR0	3F3F
RPINR7	068E	—	—	IC2R5	IC2R4	IC2R3	IC2R2	IC2R1	IC2R0	—	—	IC1R5	IC1R4	IC1R3	IC1R2	IC1R1	IC1R0	3F3F
RPINR11	0696	—	—	—	—	—	—	—	—	—	—	OCFAR5	OCFAR4	OCFAR3	OCFAR2	OCFAR1	OCFAR0	3F3F
RPINR18	06A4	—	—	U1CTSR5	U1CTSR4	U1CTSR3	U1CTSR2	U1CTSR1	U1CTSR0	—	—	U1RXR5	U1RXR4	U1RXR3	U1RXR2	U1RXR1	U1RXR0	003F
RPINR20	06A8	—	—	SCK1R5	SCK1R4	SCK1R3	SCK1R2	SCK1R1	SCK1R0	—	—	SDI1R5	SDI1R4	SDI1R3	SDI1R2	SDI1R1	SDI1R0	3F3F
RPINR21	06AA	—	—	—	—	—	—	—	—	—	—	SS1R5	SS1R4	SS1R3	SS1R2	SS1R1	SS1R0	0000
RPINR29	06BA	—	—	FLT1R5	FLT1R4	FLT1R3	FLT1R2	FLT1R1	FLT1R0	—	—	—	—	—	—	—	—	3F00
RPINR30	06BC	—	—	FLT3R5	FLT3R4	FLT3R3	FLT3R2	FLT3R1	FLT3R0	—	—	FLT2R5	FLT2R4	FLT2R3	FLT2R2	FLT2R1	FLT2R0	3F3F
RPINR31	06BE	—	—	FLT5R5	FLT5R4	FLT5R3	FLT5R2	FLT5R1	FLT5R0	—	—	FLT4R5	FLT4R4	FLT4R3	FLT4R2	FLT4R1	FLT4R0	3F3F
RPINR32	06C0	—	—	FLT7R5	FLT7R4	FLT7R3	FLT7R2	FLT7R1	FLT7R0	—	—	FLT6R5	FLT6R4	FLT6R3	FLT6R2	FLT6R1	FLT6R0	3F3F
RPINR33	06C2	—	—	SYNCI1R5	SYNCI1R4	SYNCI1R3	SYNCI1R2	SYNCI1R1	SYNCI1R0	—	—	FLT8R5	FLT8R4	FLT8R3	FLT8R2	FLT8R1	FLT8R0	3F3F
RPINR34	06C4	—	—	—	—	—	—	—	—	—	—	SYNCI2R5	SYNCI2R4	SYNCI2R3	SYNCI2R2	SYNCI2R1	SYNCI2R0	3F3F

Legend: x = unknown value on Reset, — = unimplemented, read as '0'. Reset values are shown in hexadecimal.

TABLE 4-34: PERIPHERAL PIN SELECT OUTPUT REGISTER MAP FOR dsPIC33FJ06GS101

File Name	SFR Addr	Bit 15	Bit 14	Bit 13	Bit 12	Bit 11	Bit 10	Bit 9	Bit 8	Bit 7	Bit 6	Bit 5	Bit 4	Bit 3	Bit 2	Bit 1	Bit 0	All Resets
RPOR0	06D0	—	—	RP1R5	RP1R4	RP1R3	RP1R2	RP1R1	RP1R0	—	—	RP0R5	RP0R4	RP0R3	RP0R2	RP0R1	RP0R0	0000
RPOR1	06D2	—	—	RP3R5	RP3R4	RP3R3	RP3R2	RP3R1	RP3R0	—	—	RP2R5	RP2R4	RP2R3	RP2R2	RP2R1	RP2R0	0000
RPOR2	06D4	—	—	RP5R5	RP5R4	RP5R3	RP5R2	RP5R1	RP5R0	—	—	RP4R5	RP4R4	RP4R3	RP4R2	RP4R1	RP4R0	0000
RPOR3	06D6	—	—	RP7R5	RP7R4	RP7R3	RP7R2	RP7R1	RP7R0	—	—	RP6R5	RP6R4	RP6R3	RP6R2	RP6R1	RP6R0	0000
RPOR16	06F0	—	—	RP33R5	RP33R4	RP33R3	RP33R2	RP33R1	RP33R0	—	—	RP32R5	RP32R4	RP32R3	RP32R2	RP32R1	RP32R0	0000
RPOR17	06F2	—	—	RP35R5	RP35R4	RP35R3	RP35R2	RP35R1	RP35R0	—	—	RP34R5	RP34R4	RP34R3	RP34R2	RP34R1	RP34R0	0000

Legend: x = unknown value on Reset, — = unimplemented, read as '0'. Reset values are shown in hexadecimal.

TABLE 4-35: PERIPHERAL PIN SELECT OUTPUT REGISTER MAP FOR dsPIC33FJ06GS102, dsPIC33FJ06GS202, dsPIC33FJ16GS402 AND dsPIC33FJ16GS502

File Name	SFR Addr	Bit 15	Bit 14	Bit 13	Bit 12	Bit 11	Bit 10	Bit 9	Bit 8	Bit 7	Bit 6	Bit 5	Bit 4	Bit 3	Bit 2	Bit 1	Bit 0	All Resets
RPOR0	06D0	—	—	RP1R5	RP1R4	RP1R3	RP1R2	RP1R1	RP1R0	—	—	RP0R5	RP0R4	RP0R3	RP0R2	RP0R1	RP0R0	0000
RPOR1	06D2	—	—	RP3R5	RP3R4	RP3R3	RP3R2	RP3R1	RP3R0	—	—	RP2R5	RP2R4	RP2R3	RP2R2	RP2R1	RP2R0	0000
RPOR2	06D4	—	—	RP5R5	RP5R4	RP5R3	RP5R2	RP5R1	RP5R0	—	—	RP4R5	RP4R4	RP4R3	RP4R2	RP4R1	RP4R0	0000
RPOR3	06D6	—	—	RP7R5	RP7R4	RP7R3	RP7R2	RP7R1	RP7R0	—	—	RP6R5	RP6R4	RP6R3	RP6R2	RP6R1	RP6R0	0000
RPOR4	06D8	—	—	RP9R5	RP9R4	RP9R3	RP9R2	RP9R1	RP9R0	—	—	RP8R5	RP8R4	RP8R3	RP8R2	RP8R1	RP8R0	0000
RPOR5	06DA	—	—	RP11R5	RP11R4	RP11R3	RP11R2	RP11R1	RP11R0	—	—	RP10R5	RP10R4	RP10R3	RP10R2	RP10R1	RP10R0	0000
RPOR6	06DC	—	—	RP13R5	RP13R4	RP13R3	RP13R2	RP13R1	RP13R0	—	—	RP12R5	RP12R4	RP12R3	RP12R2	RP12R1	RP12R0	0000
RPOR7	06DE	—	—	RP15R5	RP15R4	RP15R3	RP15R2	RP15R1	RP15R0	—	—	RP14R5	RP14R4	RP14R3	RP14R2	RP14R1	RP14R0	0000
RPOR16	06F0	—	—	RP33R5	RP33R4	RP33R3	RP33R2	RP33R1	RP33R0	—	—	RP32R5	RP32R4	RP32R3	RP32R2	RP32R1	RP32R0	0000
RPOR17	06F2	—	—	RP35R5	RP35R4	RP35R3	RP35R2	RP35R1	RP35R0	—	—	RP34R5	RP34R4	RP34R3	RP34R2	RP34R1	RP34R0	0000

Legend: x = unknown value on Reset, — = unimplemented, read as '0'. Reset values are shown in hexadecimal.

TABLE 4-36: PERIPHERAL PIN SELECT OUTPUT REGISTER MAP FOR dsPIC33FJ16GS404 AND dsPIC33FJ16GS504

File Name	SFR Addr	Bit 15	Bit 14	Bit 13	Bit 12	Bit 11	Bit 10	Bit 9	Bit 8	Bit 7	Bit 6	Bit 5	Bit 4	Bit 3	Bit 2	Bit 1	Bit 0	All Resets
RPOR0	06D0	—	—	RP1R5	RP1R4	RP1R3	RP1R2	RP1R1	RP1R0	—	—	RP0R5	RP0R4	RP0R3	RP0R2	RP0R1	RP0R0	0000
RPOR1	06D2	—	—	RP3R5	RP3R4	RP3R3	RP3R2	RP3R1	RP3R0	—	—	RP2R5	RP2R4	RP2R3	RP2R2	RP2R1	RP2R0	0000
RPOR2	06D4	—	—	RP5R5	RP5R4	RP5R3	RP5R2	RP5R1	RP5R0	—	—	RP4R5	RP4R4	RP4R3	RP4R2	RP4R1	RP4R0	0000
RPOR3	06D6	—	—	RP7R5	RP7R4	RP7R3	RP7R2	RP7R1	RP7R0	—	—	RP6R5	RP6R4	RP6R3	RP6R2	RP6R1	RP6R0	0000
RPOR4	06D8	—	—	RP9R5	RP9R4	RP9R3	RP9R2	RP9R1	RP9R0	—	—	RP8R5	RP8R4	RP8R3	RP8R2	RP8R1	RP8R0	0000
RPOR5	06DA	—	—	RP11R5	RP11R4	RP11R3	RP11R2	RP11R1	RP11R0	—	—	RP10R5	RP10R4	RP10R3	RP10R2	RP10R1	RP10R0	0000
RPOR6	06DC	—	—	RP13R5	RP13R4	RP13R3	RP13R2	RP13R1	RP13R0	—	—	RP12R5	RP12R4	RP12R3	RP12R2	RP12R1	RP12R0	0000
RPOR7	06DE	—	—	RP15R5	RP15R4	RP15R3	RP15R2	RP15R1	RP15R0	—	—	RP14R5	RP14R4	RP14R3	RP14R2	RP14R1	RP14R0	0000
RPOR8	06E0	—	—	RP17R5	RP17R4	RP17R3	RP17R2	RP17R1	RP17R0	—	—	RP16R5	RP16R4	RP16R3	RP16R2	RP16R1	RP16R0	0000
RPOR9	06E2	—	—	RP19R5	RP19R4	RP19R3	RP19R2	RP19R1	RP19R0	—	—	RP18R5	RP18R4	RP18R3	RP18R2	RP18R1	RP18R0	0000
RPOR10	06E4	—	—	RP21R5	RP21R4	RP21R3	RP21R2	RP21R1	RP21R0	—	—	RP20R5	RP20R4	RP20R3	RP20R2	RP20R1	RP20R0	0000
RPOR11	06E6	—	—	RP23R5	RP23R4	RP23R3	RP23R2	RP23R1	RP23R0	—	—	RP22R5	RP22R4	RP22R3	RP22R2	RP22R1	RP22R0	0000
RPOR12	06E8	—	—	RP25R5	RP25R4	RP25R3	RP25R2	RP25R1	RP25R0	—	—	RP24R5	RP24R4	RP24R3	RP24R2	RP24R1	RP24R0	0000
RPOR13	06EA	—	—	RP27R5	RP27R4	RP27R3	RP27R2	RP27R1	RP27R0	—	—	RP26R5	RP26R4	RP26R3	RP26R2	RP26R1	RP26R0	0000
RPOR14	06EC	—	—	RP29R5	RP29R4	RP29R3	RP29R2	RP29R1	RP29R0	—	—	RP28R5	RP28R4	RP28R3	RP28R2	RP28R1	RP28R0	0000
RPOR16	06F0	—	—	RP33R5	RP33R4	RP33R3	RP33R2	RP33R1	RP33R0	—	—	RP32R5	RP32R4	RP32R3	RP32R2	RP32R1	RP32R0	0000
RPOR17	06F2	—	—	RP35R5	RP35R4	RP35R3	RP35R2	RP35R1	RP35R0	—	—	RP34R5	RP34R4	RP34R3	RP34R2	RP34R1	RP34R0	0000

Legend: x = unknown value on Reset, — = unimplemented, read as '0'. Reset values are shown in hexadecimal.

TABLE 4-37: PORTA REGISTER MAP

File Name	SFR Addr	Bit 15	Bit 14	Bit 13	Bit 12	Bit 11	Bit 10	Bit 9	Bit 8	Bit 7	Bit 6	Bit 5	Bit 4	Bit 3	Bit 2	Bit 1	Bit 0	All Resets
TRISA	02C0	—	—	—	—	—	—	—	—	—	—	—	TRISA<4:0>					001F
PORTA	02C2	—	—	—	—	—	—	—	—	—	—	—	RA<4:0>					xxxx
LATA	02C4	—	—	—	—	—	—	—	—	—	—	—	LATA<4:0>					0000
ODCA	02C6	—	—	—	—	—	—	—	—	—	—	—	ODCA<4:3>		—	—	—	0000

Legend: x = unknown value on Reset, — = unimplemented, read as '0'. Reset values are shown in hexadecimal.

TABLE 4-38: PORTB REGISTER MAP FOR dsPIC33FJ06GS101

File Name	SFR Addr	Bit 15	Bit 14	Bit 13	Bit 12	Bit 11	Bit 10	Bit 9	Bit 8	Bit 7	Bit 6	Bit 5	Bit 4	Bit 3	Bit 2	Bit 1	Bit 0	All Resets
TRISB	02C8	—	—	—	—	—	—	—	—	TRISB<7:0>								00FF
PORTB	02CA	—	—	—	—	—	—	—	—	RB<7:0>								xxxx
LATB	02CC	—	—	—	—	—	—	—	—	LATB<7:0>								0000
ODCB	02CE	—	—	—	—	—	—	—	—	ODCB<7:6>		—	ODCB4	—	—	—	—	0000

Legend: x = unknown value on Reset, — = unimplemented, read as '0'. Reset values are shown in hexadecimal.

TABLE 4-39: PORTB REGISTER MAP FOR dsPIC33FJ06GS102, dsPIC33FJ06GS202, dsPIC33FJ16GS402, dsPIC33FJ16GS404, dsPIC33FJ16GS502 AND dsPIC33FJ16GS504

File Name	SFR Addr	Bit 15	Bit 14	Bit 13	Bit 12	Bit 11	Bit 10	Bit 9	Bit 8	Bit 7	Bit 6	Bit 5	Bit 4	Bit 3	Bit 2	Bit 1	Bit 0	All Resets	
TRISB	02C8	TRISB<15:0>																FFFF	
PORTB	02CA	RB<15:0>																xxxx	
LATB	02CC	LATB<15:0>																0000	
ODCB	02CE	ODCB<15:11>						—	—	ODCB<8:6>			—	ODCB4 ⁽¹⁾	—	—	—	—	0000

Legend: x = unknown value on Reset, — = unimplemented, read as '0'. Reset values are shown in hexadecimal.

Note 1: This bit is not available on dsPIC33FJ06GS202/502 devices.

TABLE 4-40: PORTC REGISTER MAP FOR dsPIC33FJ16GS404 AND dsPIC33FJ16GS504

SFR Name	SFR Addr	Bit 15	Bit 14	Bit 13	Bit 12	Bit 11	Bit 10	Bit 9	Bit 8	Bit 7	Bit 6	Bit 5	Bit 4	Bit 3	Bit 2	Bit 1	Bit 0	All Resets
TRISC	02D0	—	—	TRISC<13:0>										3FFF				
PORTC	02D2	—	—	RC<13:0>										xxxx				
LATC	02D4	—	—	LATC<13:0>										0000				
ODCC	02D6	—	—	ODCC<13:11>				—	—	ODCC<8:3>				—	—	—	ODCC0	0000

Legend: x = unknown value on Reset, — = unimplemented, read as '0'. Reset values are shown in hexadecimal.

TABLE 4-41: SYSTEM CONTROL REGISTER MAP

File Name	SFR Addr	Bit 15	Bit 14	Bit 13	Bit 12	Bit 11	Bit 10	Bit 9	Bit 8	Bit 7	Bit 6	Bit 5	Bit 4	Bit 3	Bit 2	Bit 1	Bit 0	All Resets
RCON	0740	TRAPR	IOPUWR	—	—	—	—	CM	VREGS	EXTR	SWR	SWDTEN	WDTO	SLEEP	IDLE	BOR	POR	xxxx ⁽¹⁾
OSCCON	0742	—	COSC2	COSC1	COSC0	—	NOSC2	NOSC1	NOSC0	CLKLOCK	IOLOCK	LOCK	—	CF	—	—	OSWEN	0300 ⁽²⁾
CLKDIV	0744	ROI	DOZE2	DOZE1	DOZE0	DOZEN	FRCDIV2	FRCDIV1	FRCDIV0	PLLPOST1	PLLPOST0	—	PLLPRE4	PLLPRE3	PLLPRE2	PLLPRE1	PLLPRE0	3040
PLLFBD	0746	—	—	—	—	—	—	—	—	—	—	—	PLLDIV<8:0>				0030	
REFOCON	074E	ROON	—	ROSSLP	ROSEL	RODIV3	RODIV2	RODIV1	RODIV0	—	—	—	—	—	—	—	—	0000
OSCTUN	0748	—	—	—	—	—	—	—	—	—	—	—	TUN<5:0>				0000	
ACLKCON	0750	ENAPLL	APLLCK	SELACLK	—	—	APSTSCLR2	APSTSCLR1	APSTSCLR0	ASRCSEL	FRCSEL	—	—	—	—	—	—	2300

Legend: x = unknown value on Reset, — = unimplemented, read as '0'. Reset values are shown in hexadecimal.

Note 1: The RCON register Reset values are dependent on the type of Reset.

2: The OSCCON register Reset values are dependent on the FOSCx Configuration bits and on type of Reset.

TABLE 4-42: NVM REGISTER MAP

File Name	SFR Addr	Bit 15	Bit 14	Bit 13	Bit 12	Bit 11	Bit 10	Bit 9	Bit 8	Bit 7	Bit 6	Bit 5	Bit 4	Bit 3	Bit 2	Bit 1	Bit 0	All Resets
NVMCON	0760	WR	WREN	WRERR	—	—	—	—	—	—	ERASE	—	—	NVMOP3	NVMOP2	NVMOP1	NVMOP0	0000 ⁽¹⁾
NVMKEY	0766	—	—	—	—	—	—	—	—	—	—	—	NVMKEY<7:0>				0000	

Legend: x = unknown value on Reset, — = unimplemented, read as '0'. Reset values are shown in hexadecimal.

Note 1: Reset value shown is for POR only. The value on other Reset states is dependent on the state of memory write or erase operations at the time of Reset.

TABLE 4-43: PMD REGISTER MAP FOR dsPIC33FJ06GS101 DEVICES ONLY

File Name	SFR Addr	Bit 15	Bit 14	Bit 13	Bit 12	Bit 11	Bit 10	Bit 9	Bit 8	Bit 7	Bit 6	Bit 5	Bit 4	Bit 3	Bit 2	Bit 1	Bit 0	All Resets
PMD1	0770	—	—	—	T2MD	T1MD	—	PWMMD	—	I2C1MD	—	U1MD	—	SPI1MD	—	—	ADCMD	0000
PMD2	0772	—	—	—	—	—	—	IC2MD	IC1MD	—	—	—	—	—	—	OC2MD	OC1MD	0000
PMD3	0774	—	—	—	—	—	CMPMD	—	—	—	—	—	—	—	—	—	—	0000
PMD4	0776	—	—	—	—	—	—	—	—	—	—	—	—	REFOMD	—	—	—	0000
PMD6	077A	—	—	—	—	PWM4MD	—	—	PWM1MD	—	—	—	—	—	—	—	—	0000

Legend: x = unknown value on Reset, — = unimplemented, read as '0'. Reset values are shown in hexadecimal.

TABLE 4-44: PMD REGISTER MAP FOR dsPIC33FJ06GS102 DEVICES ONLY

File Name	SFR Addr	Bit 15	Bit 14	Bit 13	Bit 12	Bit 11	Bit 10	Bit 9	Bit 8	Bit 7	Bit 6	Bit 5	Bit 4	Bit 3	Bit 2	Bit 1	Bit 0	All Resets
PMD1	0770	—	—	—	T2MD	T1MD	—	PWMMD	—	I2C1MD	—	U1MD	—	SPI1MD	—	—	ADCMD	0000
PMD2	0772	—	—	—	—	—	—	IC2MD	IC1MD	—	—	—	—	—	—	OC2MD	OC1MD	0000
PMD3	0774	—	—	—	—	—	CMPMD	—	—	—	—	—	—	—	—	—	—	0000
PMD4	0776	—	—	—	—	—	—	—	—	—	—	—	—	REFOMD	—	—	—	0000
PMD6	077A	—	—	—	—	—	—	PWM2MD	PWM1MD	—	—	—	—	—	—	—	—	0000

Legend: x = unknown value on Reset, — = unimplemented, read as '0'. Reset values are shown in hexadecimal.

TABLE 4-45: PMD REGISTER MAP FOR dsPIC33FJ06GS202 DEVICES ONLY

SFR Name	SFR Addr	Bit 15	Bit 14	Bit 13	Bit 12	Bit 11	Bit 10	Bit 9	Bit 8	Bit 7	Bit 6	Bit 5	Bit 4	Bit 3	Bit 2	Bit 1	Bit 0	All Resets
PMD1	0770	—	—	—	T2MD	T1MD	—	PWMMD	—	I2C1MD	—	U1MD	—	SPI1MD	—	—	ADCMD	0000
PMD2	0772	—	—	—	—	—	—	—	IC1MD	—	—	—	—	—	—	—	OC1MD	0000
PMD3	0774	—	—	—	—	—	CMPMD	—	—	—	—	—	—	—	—	—	—	0000
PMD4	0776	—	—	—	—	—	—	—	—	—	—	—	—	REFOMD	—	—	—	0000
PMD6	077A	—	—	—	—	—	—	PWM2MD	PWM1MD	—	—	—	—	—	—	—	—	0000
PMD7	077C	—	—	—	—	—	—	CMP2MD	CMP1MD	—	—	—	—	—	—	—	—	0000

Legend: x = unknown value on Reset, — = unimplemented, read as '0'. Reset values are shown in hexadecimal.

TABLE 4-46: PMD REGISTER MAP FOR dsPIC33FJ16GS402 AND dsPIC33FJ16GS404 DEVICES ONLY

SFR Name	SFR Addr	Bit 15	Bit 14	Bit 13	Bit 12	Bit 11	Bit 10	Bit 9	Bit 8	Bit 7	Bit 6	Bit 5	Bit 4	Bit 3	Bit 2	Bit 1	Bit 0	All Resets
PMD1	0770	—	—	T3MD	T2MD	T1MD	—	PWMMD	—	I2C1MD	—	U1MD	—	SPI1MD	—	—	ADCMD	0000
PMD2	0772	—	—	—	—	—	—	IC2MD	IC1MD	—	—	—	—	—	—	OC2MD	OC1MD	0000
PMD3	0774	—	—	—	—	—	—	—	—	—	—	—	—	—	—	—	—	0000
PMD4	0776	—	—	—	—	—	—	—	—	—	—	—	—	REFOMD	—	—	—	0000
PMD6	077A	—	—	—	—	—	PWM3MD	PWM2MD	PWM1MD	—	—	—	—	—	—	—	—	0000
PMD7	077C	—	—	—	—	—	—	—	—	—	—	—	—	—	—	—	—	0000

Legend: x = unknown value on Reset, — = unimplemented, read as '0'. Reset values are shown in hexadecimal.

TABLE 4-47: PMD REGISTER MAP FOR dsPIC33FJ16GS502 AND dsPIC33FJ16GS504 DEVICES ONLY

SFR Name	SFR Addr	Bit 15	Bit 14	Bit 13	Bit 12	Bit 11	Bit 10	Bit 9	Bit 8	Bit 7	Bit 6	Bit 5	Bit 4	Bit 3	Bit 2	Bit 1	Bit 0	All Resets
PMD1	0770	—	—	T3MD	T2MD	T1MD	—	PWMMD	—	I2C1MD	—	U1MD	—	SPI1MD	—	—	ADCMD	0000
PMD2	0772	—	—	—	—	—	—	IC2MD	IC1MD	—	—	—	—	—	—	OC2MD	OC1MD	0000
PMD3	0774	—	—	—	—	—	CMPMD	—	—	—	—	—	—	—	—	—	—	0000
PMD4	0776	—	—	—	—	—	—	—	—	—	—	—	—	REFOMD	—	—	—	0000
PMD6	077A	—	—	—	—	PWM4MD	PWM3MD	PWM2MD	PWM1MD	—	—	—	—	—	—	—	—	0000
PMD7	077C	—	—	—	—	CMP4MD	CMP3MD	CMP2MD	CMP1MD	—	—	—	—	—	—	—	—	0000

Legend: x = unknown value on Reset, — = unimplemented, read as '0'. Reset values are shown in hexadecimal.

dsPIC33FJ06GS101/X02 and dsPIC33FJ16GSX02/X04

4.2.6 SOFTWARE STACK

In addition to its use as a Working register, the W15 register in the dsPIC33FJ06GS101/X02 and dsPIC33FJ16GSX02/X04 devices is also used as a software Stack Pointer. The Stack Pointer always points to the first available free word and grows from lower to higher addresses. It predecrements for stack pops and post-increments for stack pushes, as shown in Figure 4-6. For a PC push during any CALL instruction, the MSb of the PC is zero-extended before the push, ensuring that the MSb is always clear.

Note: A PC push during exception processing concatenates the SRL register to the MSb of the PC prior to the push.

The Stack Pointer Limit register (SPLIM) associated with the Stack Pointer sets an upper address boundary for the stack. SPLIM is uninitialized at Reset. As is the case for the Stack Pointer, SPLIM<0> is forced to '0' because all stack operations must be word-aligned.

Whenever an EA is generated using W15 as a source or destination pointer, the resulting address is compared with the value in SPLIM. If the contents of the Stack Pointer (W15) and the SPLIM register are equal and a push operation is performed, a stack error trap will not occur. The stack error trap will occur on a subsequent push operation. For example, to cause a stack error trap when the stack grows beyond address 0x1000 in RAM, initialize the SPLIM with the value 0x0FFE.

Similarly, a Stack Pointer underflow (stack error) trap is generated when the Stack Pointer address is found to be less than 0x0800. This prevents the stack from interfering with the Special Function Register (SFR) space.

A write to the SPLIM register should not be immediately followed by an indirect read operation using W15.

FIGURE 4-6: CALL STACK FRAME



4.3 Instruction Addressing Modes

The addressing modes shown in Table 4-48 form the basis of the addressing modes optimized to support the specific features of individual instructions. The addressing modes provided in the MAC class of instructions differ from those in the other instruction types.

4.3.1 FILE REGISTER INSTRUCTIONS

Most file register instructions use a 13-bit address field (f) to directly address data present in the first 8192 bytes of data memory (Near Data Space). Most file register instructions employ a Working register, W0, which is denoted as WREG in these instructions. The destination is typically either the same file register or WREG (with the exception of the MUL instruction), which writes the result to a register or register pair. The MOV instruction allows additional flexibility and can access the entire data space.

4.3.2 MCU INSTRUCTIONS

The three-operand MCU instructions are of the form:

Operand 3 = Operand 1 <function> Operand 2

where, Operand 1 is always a Working register (that is, the addressing mode can only be register direct), which is referred to as Wb. Operand 2 can be a W register, fetched from data memory, or a 5-bit literal. The result location can be either a W register or a data memory location. The following addressing modes are supported by MCU instructions:

- Register Direct
- Register Indirect
- Register Indirect Post-Modified
- Register Indirect Pre-Modified
- 5-bit or 10-bit Literal

Note: Not all instructions support all the addressing modes given above. Individual instructions can support different subsets of these addressing modes.

dsPIC33FJ06GS101/X02 and dsPIC33FJ16GSX02/X04

TABLE 4-48: FUNDAMENTAL ADDRESSING MODES SUPPORTED

Addressing Mode	Description
File Register Direct	The address of the file register is specified explicitly.
Register Direct	The contents of a register are accessed directly.
Register Indirect	The contents of Wn forms the Effective Address (EA).
Register Indirect Post-Modified	The contents of Wn forms the EA. Wn is post-modified (incremented or decremented) by a constant value.
Register Indirect Pre-Modified	Wn is pre-modified (incremented or decremented) by a signed constant value to form the EA.
Register Indirect with Register Offset (Register Indexed)	The sum of Wn and Wb forms the EA.
Register Indirect with Literal Offset	The sum of Wn and a literal forms the EA.

4.3.3 MOVE AND ACCUMULATOR INSTRUCTIONS

Move instructions and the DSP accumulator class of instructions to provide a greater addressing flexibility than other instructions. In addition to the addressing modes supported by most MCU instructions, move and accumulator instructions also support Register Indirect with Register Offset Addressing mode, also referred to as Register Indexed mode.

Note: For the `MOV` instructions, the addressing mode specified in the instruction can differ for the source and destination EA. However, the 4-bit Wb (register offset) field is shared by both source and destination (but typically only used by one).

In summary, the following addressing modes are supported by move and accumulator instructions:

- Register Direct
- Register Indirect
- Register Indirect Post-modified
- Register Indirect Pre-modified
- Register Indirect with Register Offset (Indexed)
- Register Indirect with Literal Offset
- 8-bit Literal
- 16-bit Literal

Note: Not all instructions support all the addressing modes given above. Individual instructions may support different subsets of these addressing modes.

4.3.4 MAC INSTRUCTIONS

The dual source operand DSP instructions (`CLR`, `ED`, `EDAC`, `MAC`, `MPY`, `MPY.N`, `MOVSAC` and `MSC`), also referred to as `MAC` instructions, use a simplified set of addressing modes to allow the user application to effectively manipulate the Data Pointers through register indirect tables.

The two-source operand prefetch registers must be members of the set {W8, W9, W10, W11}. For data reads, W8 and W9 are always directed to the X RAGU, and W10 and W11 are always directed to the Y AGU. The Effective Addresses generated (before and after modification) must, therefore, be valid addresses within X data space for W8 and W9 and Y data space for W10 and W11.

Note: Register Indirect with Register Offset Addressing mode is available only for W9 (in X space) and W11 (in Y space).

In summary, the following addressing modes are supported by the `MAC` class of instructions:

- Register Indirect
- Register Indirect Post-Modified by 2
- Register Indirect Post-Modified by 4
- Register Indirect Post-Modified by 6
- Register Indirect with Register Offset (Indexed)

4.3.5 OTHER INSTRUCTIONS

Besides the addressing modes outlined previously, some instructions use literal constants of various sizes. For example, `BRA` (branch) instructions use 16-bit signed literals to specify the branch destination directly, whereas the `DISI` instruction uses a 14-bit unsigned literal field. In some instructions, such as `ADD Acc`, the source of an operand or result is implied by the opcode itself. Certain operations, such as `NOP`, do not have any operands.

4.4 Modulo Addressing

Modulo Addressing mode is a method used to provide an automated means to support circular data buffers using hardware. The objective is to remove the need for software to perform data address boundary checks when executing tightly looped code, as is typical in many DSP algorithms.

Modulo Addressing can operate in either data or program space (since the Data Pointer mechanism is essentially the same for both). One circular buffer can be supported in each of the X (which also provides the pointers into program space) and Y data spaces. Modulo Addressing can operate on any W register Pointer. However, it is not advisable to use W14 or W15 for Modulo Addressing since these two registers are used as the Stack Frame Pointer and Stack Pointer, respectively.

In general, any particular circular buffer can be configured to operate in only one direction as there are certain restrictions on the buffer start address (for incrementing buffers), or end address (for decrementing buffers), based upon the direction of the buffer.

The only exception to the usage restrictions is for buffers that have a power-of-two length. As these buffers satisfy the start and end address criteria, they can operate in a bidirectional mode (that is, address boundary checks are performed on both the lower and upper address boundaries).

4.4.1 START AND END ADDRESS

The Modulo Addressing scheme requires that a starting and ending address be specified and loaded into the 16-bit Modulo Buffer Address registers: XMODSRT, XMODEND, YMODSRT and YMODEND (see Table 4-1).

Note: Y space Modulo Addressing EA calculations assume word-sized data (LSb of every EA is always clear).

The length of a circular buffer is not directly specified. It is determined by the difference between the corresponding start and end addresses. The maximum possible length of the circular buffer is 32K words (64 Kbytes).

4.4.2 W ADDRESS REGISTER SELECTION

The Modulo and Bit-Reversed Addressing Control register, MODCON<15:0>, contains enable flags as well as a W register field to specify the W Address registers. The XWM and YWM fields select the registers that will operate with Modulo Addressing:

- If XWM = 15, X RAGU and X WAGU Modulo Addressing is disabled.
- If YWM = 15, Y AGU Modulo Addressing is disabled.

The X Address Space Pointer W register (XWM), to which Modulo Addressing is to be applied, is stored in MODCON<3:0> (see Table 4-1). Modulo Addressing is enabled for X data space when XWM is set to any value other than '15' and the XMODEN bit is set at MODCON<15>.

The Y Address Space Pointer W register (YWM) to which Modulo Addressing is to be applied is stored in MODCON<7:4>. Modulo Addressing is enabled for Y data space when YWM is set to any value other than '15' and the YMODEN bit is set at MODCON<14>.

FIGURE 4-7: MODULO ADDRESSING OPERATION EXAMPLE

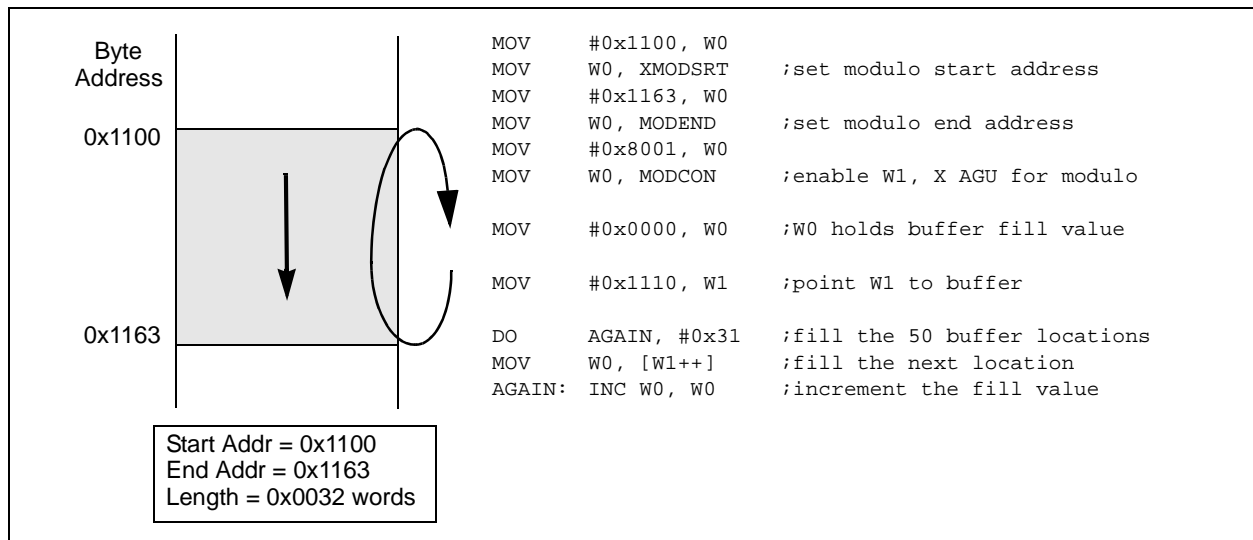

dsPIC33FJ06GS101/X02 and dsPIC33FJ16GSX02/X04

4.4.3 MODULO ADDRESSING APPLICABILITY

Modulo Addressing can be applied to the Effective Address (EA) calculation associated with any W register. Address boundaries check for addresses equal to:

- The upper boundary addresses for incrementing buffers
- The lower boundary addresses for decrementing buffers

The address boundaries check for addresses less than or greater than the upper (for incrementing buffers) and lower (for decrementing buffers) boundary addresses (not just equal to). Address changes can, therefore, jump beyond boundaries and still be adjusted correctly.

Note: The modulo corrected Effective Address is written back to the register only when Pre-Modify or Post-Modify Addressing mode is used to compute the Effective Address. When an address offset (such as [W7 + W2]) is used, Modulo Addressing correction is performed but the contents of the register remain unchanged.

4.5 Bit-Reversed Addressing

Bit-Reversed Addressing mode is intended to simplify data re-ordering for radix-2 FFT algorithms. It is supported by the X AGU for data writes only.

The modifier, which can be a constant value or register contents, is regarded as having its bit order reversed. The address source and destination are kept in normal order. Thus, the only operand requiring reversal is the modifier.

4.5.1 BIT-REVERSED ADDRESSING IMPLEMENTATION

Bit-Reversed Addressing mode is enabled in any of these situations:

- BWM bits (W register selection) in the MODCON register are any value other than 15 (the stack cannot be accessed using Bit-Reversed Addressing)
- The BREN bit is set in the XBREV register
- The addressing mode used is Register Indirect with Pre-Increment or Post-Increment

If the length of a bit-reversed buffer is $M = 2^N$ bytes, the last 'N' bits of the data buffer start address must be zeros.

XB<14:0> is the Bit-Reversed Address modifier, or 'pivot point,' which is typically a constant. In the case of an FFT computation, its value is equal to half of the FFT data buffer size.

Note: All bit-reversed EA calculations assume word-sized data (LSb of every EA is always clear). The XB value is scaled accordingly to generate compatible (byte) addresses.

When enabled, Bit-Reversed Addressing is executed only for Register Indirect with Pre-Increment or Post-Increment Addressing and word-sized data writes. It will not function for any other addressing mode or for byte-sized data, and normal addresses are generated instead. When Bit-Reversed Addressing is active, the W Address Pointer is always added to the address modifier (XB), and the offset associated with the Register Indirect Addressing mode is ignored. In addition, as word-sized data is a requirement, the LSb of the EA is ignored (and always clear).

Note: Modulo Addressing and Bit-Reversed Addressing should not be enabled together. If an application attempts to do so, Bit-Reversed Addressing will assume priority when active for the X WAGU and X WAGU; Modulo Addressing will be disabled. However, Modulo Addressing will continue to function in the X RAGU.

If Bit-Reversed Addressing has already been enabled by setting the BREN (XBREV<15>) bit, a write to the XBREV register should not be immediately followed by an indirect read operation using the W register that has been designated as the Bit-Reversed Pointer.

dsPIC33FJ06GS101/X02 and dsPIC33FJ16GSX02/X04

FIGURE 4-8: BIT-REVERSED ADDRESS EXAMPLE



TABLE 4-49: BIT-REVERSED ADDRESS SEQUENCE (16-ENTRY)

Normal Address					Bit-Reversed Address				
A3	A2	A1	A0	Decimal	A3	A2	A1	A0	Decimal
0	0	0	0	0	0	0	0	0	0
0	0	0	1	1	1	0	0	0	8
0	0	1	0	2	0	1	0	0	4
0	0	1	1	3	1	1	0	0	12
0	1	0	0	4	0	0	1	0	2
0	1	0	1	5	1	0	1	0	10
0	1	1	0	6	0	1	1	0	6
0	1	1	1	7	1	1	1	0	14
1	0	0	0	8	0	0	0	1	1
1	0	0	1	9	1	0	0	1	9
1	0	1	0	10	0	1	0	1	5
1	0	1	1	11	1	1	0	1	13
1	1	0	0	12	0	0	1	1	3
1	1	0	1	13	1	0	1	1	11
1	1	1	0	14	0	1	1	1	7
1	1	1	1	15	1	1	1	1	15

dsPIC33FJ06GS101/X02 and dsPIC33FJ16GSX02/X04

4.6 Interfacing Program and Data Memory Spaces

The dsPIC33FJ06GS101/X02 and dsPIC33FJ16GSX02/X04 architecture uses a 24-bit-wide program space and a 16-bit-wide data space. The architecture is also a modified Harvard scheme, meaning that data can also be present in the program space. To use this data successfully, it must be accessed in a way that preserves the alignment of information in both spaces.

Aside from normal execution, the dsPIC33FJ06GS101/X02 and dsPIC33FJ16GSX02/X04 architecture provides two methods by which program space can be accessed during operation:

- Using table instructions to access individual bytes or words anywhere in the program space
- Remapping a portion of the program space into the data space (Program Space Visibility)

Table instructions allow an application to read or write to small areas of the program memory. This capability makes the method ideal for accessing data tables that need to be updated periodically. It also allows access to all bytes of the program word. The remapping method allows an application to access a large block of data on a read-only basis, which is ideal for look ups from a large table of static data. The application can only access the least significant word of the program word.

4.6.1 ADDRESSING PROGRAM SPACE

Since the address ranges for the data and program spaces are 16 and 24 bits, respectively, a method is needed to create a 23-bit or 24-bit program address from 16-bit data registers. The solution depends on the interface method to be used.

For table operations, the 8-bit Table Page register (TBLPAG) is used to define a 32K word region within the program space. This is concatenated with a 16-bit EA to arrive at a full 24-bit program space address. In this format, the Most Significant bit of TBLPAG is used to determine if the operation occurs in the user memory (TBLPAG<7> = 0) or the configuration memory (TBLPAG<7> = 1).

For remapping operations, the 8-bit Program Space Visibility register (PSVPAG) is used to define a 16K word page in the program space. When the Most Significant bit of the EA is '1', PSVPAG is concatenated with the lower 15 bits of the EA to form a 23-bit program space address. Unlike table operations, this limits remapping operations strictly to the user memory area.

Table 4-50 and Figure 4-9 show how the program EA is created for table operations and remapping accesses from the data EA. Here, P<23:0> refers to a program space word, and D<15:0> refers to a data space word.

TABLE 4-50: PROGRAM SPACE ADDRESS CONSTRUCTION

Access Type	Access Space	Program Space Address				
		<23>	<22:16>	<15>	<14:1>	<0>
Instruction Access (Code Execution)	User	0	PC<22:1>			0
		0xx xxxx xxxx xxxx xxxx xxx0				
TBLRD/TBLWT (Byte/Word Read/Write)	User	TBLPAG<7:0>		Data EA<15:0>		
		0xxx xxxx xxxx xxxx xxxx xxxx				
	Configuration	TBLPAG<7:0>		Data EA<15:0>		
		1xxx xxxx xxxx xxxx xxxx xxxx				
Program Space Visibility (Block Remap/Read)	User	0	PSVPAG<7:0>		Data EA<14:0> ⁽¹⁾	
		0	xxxx xxxx xxx xxxx xxxx			

Note 1: Data EA<15> is always '1' in this case, but is not used in calculating the program space address. Bit 15 of the address is PSVPAG<0>.

dsPIC33FJ06GS101/X02 and dsPIC33FJ16GSX02/X04

FIGURE 4-9: DATA ACCESS FROM PROGRAM SPACE ADDRESS GENERATION



dsPIC33FJ06GS101/X02 and dsPIC33FJ16GSX02/X04

4.6.2 DATA ACCESS FROM PROGRAM MEMORY USING TABLE INSTRUCTIONS

The TBLRDL and TBLWTL instructions offer a direct method of reading or writing the lower word of any address within the program space without going through data space. The TBLRDH and TBLWTH instructions are the only method to read or write the upper 8 bits of a program space word as data.

The PC is incremented by two for each successive 24-bit program word. This allows program memory addresses to directly map to data space addresses. Program memory can thus be regarded as two 16-bit wide word address spaces, residing side by side, each with the same address range. TBLRDL and TBLWTL access the space that contains the least significant data word. TBLRDH and TBLWTH access the space that contains the upper data byte.

Two table instructions are provided to move byte or word-sized (16-bit) data to and from program space. Both function as either byte or word operations.

- TBLRDL (Table Read Low):
 - In Word mode, this instruction maps the lower word of the program space location (P<15:0>) to a data address (D<15:0>).

- In Byte mode, either the upper or lower byte of the lower program word is mapped to the lower byte of a data address. The upper byte is selected when byte select is '1'; the lower byte is selected when it is '0'.

- TBLRDH (Table Read High):
 - In Word mode, this instruction maps the entire upper word of a program address (P<23:16>) to a data address. Note that D<15:8>, the 'phantom byte', will always be '0'.
 - In Byte mode, this instruction maps the upper or lower byte of the program word to D<7:0> of the data address, in the TBLRDL instruction. The data is always '0' when the upper 'phantom' byte is selected (Byte Select = 1).

Similarly, two table instructions, TBLWTH and TBLWTL, are used to write individual bytes or words to a program space address. The details of their operation are explained in [Section 5.0 "Flash Program Memory"](#).

For all table operations, the area of program memory space to be accessed is determined by the Table Page register (TBLPAG). TBLPAG covers the entire program memory space of the device, including user and configuration spaces. When TBLPAG<7> = 0, the table page is located in the user memory space. When TBLPAG<7> = 1, the page is located in configuration space.

FIGURE 4-10: ACCESSING PROGRAM MEMORY WITH TABLE INSTRUCTIONS



dsPIC33FJ06GS101/X02 and dsPIC33FJ16GSX02/X04

4.6.3 READING DATA FROM PROGRAM MEMORY USING PROGRAM SPACE VISIBILITY

The upper 32 Kbytes of data space may optionally be mapped into any 16K word page of the program space. This option provides transparent access to stored constant data from the data space without the need to use special instructions (such as `TBLRDL/H`).

Program space access through the data space occurs if the Most Significant bit of the data space EA is '1' and Program Space Visibility (PSV) is enabled by setting the PSV bit in the Core Control register (`CORCON<2>`). The location of the program memory space to be mapped into the data space is determined by the Program Space Visibility Page register (`PSVPAG`). This 8-bit register defines any one of 256 possible pages of 16K words in program space. In effect, `PSVPAG` functions as the upper 8 bits of the program memory address, with the 15 bits of the EA functioning as the lower bits. By incrementing the PC by 2 for each program memory word, the lower 15 bits of data space addresses directly map to the lower 15 bits in the corresponding program space addresses.

Data reads to this area add a cycle to the instruction being executed, since two program memory fetches are required.

Although each data space address 8000h and higher maps directly into a corresponding program memory address (see [Figure 4-11](#)), only the lower 16 bits of the

24-bit program word are used to contain the data. The upper 8 bits of any program space location used as data should be programmed with '1111 1111' or '0000 0000' to force a `NOP`. This prevents possible issues should the area of code ever be accidentally executed.

Note: PSV access is temporarily disabled during Table Reads/Writes.

For operations that use PSV and are executed outside a `REPEAT` loop, the `MOV` and `MOV.D` instructions require one instruction cycle in addition to the specified execution time. All other instructions require two instruction cycles in addition to the specified execution time.

For operations that use PSV, and are executed inside a `REPEAT` loop, these instances require two instruction cycles in addition to the specified execution time of the instruction:

- Execution in the first iteration
- Execution in the last iteration
- Execution prior to exiting the loop due to an interrupt
- Execution upon re-entering the loop after an interrupt is serviced

Any other iteration of the `REPEAT` loop will allow the instruction using PSV to access data, to execute in a single cycle.

FIGURE 4-11: PROGRAM SPACE VISIBILITY OPERATION



dsPIC33FJ06GS101/X02 and dsPIC33FJ16GSX02/X04

NOTES:

dsPIC33FJ06GS101/X02 and dsPIC33FJ16GSX02/X04

5.0 FLASH PROGRAM MEMORY

Note 1: This data sheet summarizes the features of the dsPIC33FJ06GS101/X02 and dsPIC33FJ16GSX02/X04 families of devices. It is not intended to be a comprehensive reference source. To complement the information in this data sheet, refer to “Flash Programming” (DS70191) in the “dsPIC33F/PIC24H Family Reference Manual”, which is available from the Microchip web site (www.microchip.com).

2: Some registers and associated bits described in this section may not be available on all devices. Refer to [Section 4.0 “Memory Organization”](#) in this data sheet for device-specific register and bit information.

The dsPIC33FJ06GS101/X02 and dsPIC33FJ16GSX02/X04 devices contain internal Flash program memory for storing and executing application code. The memory is readable, writable and erasable during normal operation over the entire VDD range.

Flash memory can be programmed in two ways:

- In-Circuit Serial Programming™ (ICSP™) programming capability
- Run-Time Self-Programming (RTSP)

ICSP allows a dsPIC33FJ06GS101/X02 and dsPIC33FJ16GSX02/X04 device to be serially programmed while in the end application circuit. This is done with two lines for programming clock and programming data (one of the alternate programming pin pairs: PGECx/PGEDx, and three other lines for

power (VDD), ground (VSS) and Master Clear (\overline{MCLR}). This allows customers to manufacture boards with unprogrammed devices and then program the Digital Signal Controller just before shipping the product. This also allows the most recent firmware or a custom firmware to be programmed.

RTSP is accomplished using TBLRD (Table Read) and TBLWT (Table Write) instructions. With RTSP, the user application can write program memory data, either in blocks or ‘rows’ of 64 instructions (192 bytes) at a time, or a single program memory word, and erase program memory in blocks or ‘pages’ of 512 instructions (1536 bytes) at a time.

5.1 Table Instructions and Flash Programming

Regardless of the method used, all programming of Flash memory is done with the Table Read and Table Write instructions. These allow direct read and write access to the program memory space from the data memory while the device is in normal operating mode. The 24-bit target address in the program memory is formed using bits<7:0> of the TBLPAG register and the Effective Address (EA) from a W register specified in the table instruction, as shown in [Figure 5-1](#).

The TBLRDL and the TBLWTL instructions are used to read or write to bits<15:0> of program memory. TBLRDL and TBLWTL can access program memory in both Word and Byte modes.

The TBLRDH and TBLWTH instructions are used to read or write to bits<23:16> of program memory. TBLRDH and TBLWTH can also access program memory in Word or Byte mode.

FIGURE 5-1: ADDRESSING FOR TABLE REGISTERS



dsPIC33FJ06GS101/X02 and dsPIC33FJ16GSX02/X04

5.2 RTSP Operation

The dsPIC33FJ06GS101/X02 and dsPIC33FJ16GSX02/X04 Flash program memory array is organized into rows of 64 instructions or 192 bytes. RTSP allows the user application to erase a page of memory, which consists of eight rows (512 instructions) at a time, and to program one row or one word at a time. Table 24-12 shows typical erase and programming times. The 8-row erase pages and single row write rows are edge-aligned from the beginning of program memory, on boundaries of 1536 bytes and 192 bytes, respectively.

The program memory implements holding buffers that can contain 64 instructions of programming data. Prior to the actual programming operation, the write data must be loaded into the buffers sequentially. The instruction words loaded must always be from a group of 64 boundary.

The basic sequence for RTSP programming is to set up a Table Pointer, then do a series of TBLWT instructions to load the buffers. Programming is performed by setting the control bits in the NVMCON register. A total of 64 TBLWTL and TBLWTH instructions are required to load the instructions.

All of the Table Write operations are single-word writes (two instruction cycles) because only the buffers are written. A programming cycle is required for programming each row.

5.3 Programming Operations

A complete programming sequence is necessary for programming or erasing the internal Flash in RTSP mode. The processor stalls (waits) until the programming operation is finished.

The programming time depends on the FRC accuracy (see Table 24-20) and the value of the FRC Oscillator Tuning register (see Register 8-4). Use the following formula to calculate the minimum and maximum values for the Row Write Time, Page Erase Time, and Word Write Cycle Time parameters (see Table 24-12).

EQUATION 5-1: PROGRAMMING TIME

$$T = \frac{11064 \text{ Cycles}}{7.37 \text{ MHz} \times (\text{FRC Accuracy})\% \times (\text{FRC Tuning})\%}$$

For example, if the device is operating at +125°C, the FRC accuracy will be ±5%. If the TUN<5:0> bits (see Register 8-4) are set to 'b1111111, the minimum row write time is equal to Equation 5-2.

EQUATION 5-2: MINIMUM ROW WRITE TIME

$$T_{RW} = \frac{11064 \text{ Cycles}}{7.37 \text{ MHz} \times (1 + 0.05) \times (1 - 0.00375)} = 1.435 \text{ ms}$$

The maximum row write time is equal to Equation 5-3.

EQUATION 5-3: MAXIMUM ROW WRITE TIME

$$T_{RW} = \frac{11064 \text{ Cycles}}{7.37 \text{ MHz} \times (1 - 0.05) \times (1 - 0.00375)} = 1.586 \text{ ms}$$

Setting the WR bit (NVMCON<15>) starts the operation, and the WR bit is automatically cleared when the operation is finished.

5.4 Control Registers

Two SFRs are used to read and write the program Flash memory: NVMCON and NVMKEY.

The NVMCON register (Register 5-1) controls which blocks are to be erased, which memory type is to be programmed and the start of the programming cycle.

NVMKEY is a write-only register that is used for write protection. To start a programming or erase sequence, the user application must consecutively write 0x55 and 0xAA to the NVMKEY register. Refer to Section 5.3 “Programming Operations” for further details.

dsPIC33FJ06GS101/X02 and dsPIC33FJ16GSX02/X04

REGISTER 5-1: NVMCON: FLASH MEMORY CONTROL REGISTER

R/SO-0 ⁽¹⁾	R/W-0 ⁽¹⁾	R/W-0 ⁽¹⁾	U-0	U-0	U-0	U-0	U-0
WR	WREN	WRERR	—	—	—	—	—
bit 15						bit 8	

U-0	R/W-0 ⁽¹⁾	U-0	U-0	R/W-0 ⁽¹⁾	R/W-0 ⁽¹⁾	R/W-0 ⁽¹⁾	R/W-0 ⁽¹⁾
—	ERASE	—	—	NVMOP3 ⁽²⁾	NVMOP2 ⁽²⁾	NVMOP1 ⁽²⁾	NVMOP0 ⁽²⁾
bit 7						bit 0	

Legend:	SO = Settable Only bit
R = Readable bit	W = Writable bit
-n = Value at POR	'1' = Bit is set
	U = Unimplemented bit, read as '0'
	'0' = Bit is cleared
	x = Bit is unknown

- bit 15 **WR:** Write Control bit⁽¹⁾
 1 = Initiates a Flash memory program or erase operation; the operation is self-timed and the bit is cleared by hardware once the operation is complete
 0 = Program or erase operation is complete and inactive
- bit 14 **WREN:** Write Enable bit⁽¹⁾
 1 = Enable Flash program/erase operations
 0 = Inhibit Flash program/erase operations
- bit 13 **WRERR:** Write Sequence Error Flag bit⁽¹⁾
 1 = An improper program or erase sequence attempt, or termination has occurred (bit is set automatically on any set attempt of the WR bit)
 0 = The program or erase operation completed normally
- bit 12-7 **Unimplemented:** Read as '0'
- bit 6 **ERASE:** Erase/Program Enable bit⁽¹⁾
 1 = Performs the erase operation specified by NVMOP<3:0> on the next WR command
 0 = Performs the program operation specified by NVMOP<3:0> on the next WR command
- bit 5-4 **Unimplemented:** Read as '0'
- bit 3-0 **NVMOP<3:0>:** NVM Operation Select bits^(1,2)
If ERASE = 1:
 1111 = Memory bulk erase operation
 1101 = Erase general segment
 0011 = No operation
 0010 = Memory page erase operation
 0001 = No operation
 0000 = Erase a single Configuration register byte
If ERASE = 0:
 1111 = No operation
 1101 = No operation
 0011 = Memory word program operation
 0010 = No operation
 0001 = Memory row program operation
 0000 = Program a single Configuration register byte

Note 1: These bits can only be Reset on POR.

2: All other combinations of NVMOP<3:0> are unimplemented.

dsPIC33FJ06GS101/X02 and dsPIC33FJ16GSX02/X04

REGISTER 5-2: NVMKEY: NONVOLATILE MEMORY KEY REGISTER

U-0	U-0	U-0	U-0	U-0	U-0	U-0	U-0
—	—	—	—	—	—	—	—
bit 15							bit 8

W-0	W-0	W-0	W-0	W-0	W-0	W-0	W-0
NVMKEY<7:0>							
bit 7							bit 0

Legend:

R = Readable bit	W = Writable bit	U = Unimplemented bit, read as '0'
-n = Value at POR	'1' = Bit is set	'0' = Bit is cleared
		x = Bit is unknown

bit 15-8 **Unimplemented:** Read as '0'

bit 7-0 **NVMKEY<7:0>:** Nonvolatile Memory Key bits (write-only)

dsPIC33FJ06GS101/X02 and dsPIC33FJ16GSX02/X04

5.4.1 PROGRAMMING ALGORITHM FOR FLASH PROGRAM MEMORY

One row of program Flash memory can be programmed at a time. To achieve this, it is necessary to erase the 8-row erase page that contains the desired row. The general process is:

1. Read eight rows of program memory (512 instructions) and store in data RAM.
2. Update the program data in RAM with the desired new data.
3. Erase the block (see [Example 5-1](#)):
 - a) Set the NVMOP<3:0> bits (NVMCON<3:0>) to '0010' to configure for block erase. Set the ERASE (NVMCON<6>) and WREN (NVMCON<14>) bits.
 - b) Write the starting address of the page to be erased into the TBLPAG and W registers.
 - c) Write 0x55 to NVMKEY.
 - d) Write 0xAA to NVMKEY.
 - e) Set the WR bit (NVMCON<15>). The erase cycle begins and the CPU stalls for the duration of the erase cycle. When the erase is done, the WR bit is cleared automatically.
4. Write the first 64 instructions from data RAM into the program memory buffers (see [Example 5-2](#)).
5. Write the program block to Flash memory:
 - a) Set the NVMOP<3:0> bits to '0001' to configure for row programming. Clear the ERASE bit and set the WREN bit.
 - b) Write 0x55 to the NVMKEY register.
 - c) Write 0xAA to the NVMKEY register.
 - d) Set the WR bit. The programming cycle begins and the CPU stalls for the duration of the write cycle. When the write to Flash memory is done, the WR bit is cleared automatically.
6. Repeat Steps 4 and 5, using the next available 64 instructions from the block in data RAM by incrementing the value in the TBLPAG register, until all 512 instructions are written back to Flash memory.

For protection against accidental operations, the write initiate sequence for the NVMKEY register must be used to allow any erase or program operation to proceed. After the programming command has been executed, the user application must wait for the programming time until programming is complete. The two instructions following the start of the programming sequence should be NOPs, as shown in [Example 5-3](#).

EXAMPLE 5-1: ERASING A PROGRAM MEMORY PAGE

```
; Set up NVMCON for block erase operation
MOV    #0x4042, W0          ;
MOV    W0, NVMCON          ; Initialize NVMCON
; Init pointer to row to be ERASED
MOV    #tblpage(PROG_ADDR), W0      ;
MOV    W0, TBLPAG          ; Initialize PM Page Boundary SFR
MOV    #tbloffset(PROG_ADDR), W0    ; Initialize in-page EA[15:0] pointer
TBLWTL W0, [W0]             ; Set base address of erase block
DISI   #5                   ; Block all interrupts with priority <7
                                ; for next 5 instructions

MOV    #0x55, W0           ;
MOV    W0, NVMKEY          ; Write the 55 key
MOV    #0xAA, W1           ;
MOV    W1, NVMKEY          ; Write the AA key
BSET   NVMCON, #WR        ; Start the erase sequence
NOP                                ; Insert two NOPs after the erase
NOP                                ; command is asserted
```

dsPIC33FJ06GS101/X02 and dsPIC33FJ16GSX02/X04

EXAMPLE 5-2: LOADING THE WRITE BUFFERS

```
; Set up NVMCON for row programming operations
MOV    #0x4001, W0          ;
MOV    W0, NVMCON          ; Initialize NVMCON
; Set up a pointer to the first program memory location to be written
; program memory selected, and writes enabled
MOV    #0x0000, W0          ;
MOV    W0, TBLPAG          ; Initialize PM Page Boundary SFR
MOV    #0x6000, W0          ; An example program memory address
; Perform the TBLWT instructions to write the latches
; 0th_program_word
MOV    #LOW_WORD_0, W2      ;
MOV    #HIGH_BYTE_0, W3     ;
TBLWTL W2, [W0]            ; Write PM low word into program latch
TBLWTH W3, [W0++]          ; Write PM high byte into program latch
; 1st_program_word
MOV    #LOW_WORD_1, W2      ;
MOV    #HIGH_BYTE_1, W3     ;
TBLWTL W2, [W0]            ; Write PM low word into program latch
TBLWTH W3, [W0++]          ; Write PM high byte into program latch
; 2nd_program_word
MOV    #LOW_WORD_2, W2      ;
MOV    #HIGH_BYTE_2, W3     ;
TBLWTL W2, [W0]            ; Write PM low word into program latch
TBLWTH W3, [W0++]          ; Write PM high byte into program latch
.
.
.
; 63rd_program_word
MOV    #LOW_WORD_31, W2     ;
MOV    #HIGH_BYTE_31, W3    ;
TBLWTL W2, [W0]            ; Write PM low word into program latch
TBLWTH W3, [W0++]          ; Write PM high byte into program latch
```

EXAMPLE 5-3: INITIATING A PROGRAMMING SEQUENCE

```
DISI   #5                    ; Block all interrupts with priority <7
; for next 5 instructions
MOV    #0x55, W0             ;
MOV    W0, NVMKEY           ; Write the 55 key
MOV    #0xAA, W1            ;
MOV    W1, NVMKEY           ; Write the AA key
BSET   NVMCON, #WR          ; Start the erase sequence
NOP    ; Insert two NOPs after the
NOP    ; erase command is asserted
```

dsPIC33FJ06GS101/X02 and dsPIC33FJ16GSX02/X04

6.0 RESETS

Note 1: This data sheet summarizes the features of the dsPIC33FJ06GS101/X02 and dsPIC33FJ16GSX02/X04 families of devices. It is not intended to be a comprehensive reference source. To complement the information in this data sheet, refer to “Reset” (DS70192) in the “dsPIC33F/PIC24H Family Reference Manual”, which is available from the Microchip web site (www.microchip.com).

2: Some registers and associated bits described in this section may not be available on all devices. Refer to [Section 4.0 “Memory Organization”](#) in this data sheet for device-specific register and bit information.

The Reset module combines all Reset sources and controls the device Master Reset Signal, $\overline{\text{SYSRST}}$. The following is a list of device Reset sources:

- POR: Power-on Reset
- BOR: Brown-out Reset
- $\overline{\text{MCLR}}$: Master Clear Pin Reset
- SWR: Software RESET Instruction
- WDTO: Watchdog Timer Reset
- CM: Configuration Mismatch Reset
- TRAPR: Trap Conflict Reset
- IOPUWR: Illegal Condition Device Reset
 - Illegal Opcode Reset
 - Uninitialized W Register Reset
 - Security Reset

A simplified block diagram of the Reset module is shown in [Figure 6-1](#).

Any active source of Reset will make the $\overline{\text{SYSRST}}$ signal active. On system Reset, some of the registers associated with the CPU and peripherals are forced to a known Reset state and some are unaffected.

Note: Refer to the specific peripheral section or [Section 3.0 “CPU”](#) of this data sheet for register Reset states.

All types of device Reset set a corresponding status bit in the RCON register to indicate the type of Reset (see [Register 6-1](#)).

A POR clears all the bits, except for the POR bit (RCON<0>), which is set. The user application can set or clear any bit at any time during code execution. The RCON bits only serve as status bits. Setting a particular Reset status bit in software does not cause a device Reset to occur.

The RCON register also has other bits associated with the Watchdog Timer and device power-saving states. The function of these bits is discussed in other sections of this manual.

Note: The status bits in the RCON register should be cleared after they are read so that the next RCON register value after a device Reset is meaningful.

FIGURE 6-1: RESET SYSTEM BLOCK DIAGRAM



dsPIC33FJ06GS101/X02 and dsPIC33FJ16GSX02/X04

REGISTER 6-1: RCON: RESET CONTROL REGISTER⁽¹⁾

R/W-0	R/W-0	U-0	U-0	U-0	U-0	R/W-0	R/W-0
TRAPR	IOPUWR	—	—	—	—	CM	VREGS
bit 15						bit 8	

R/W-0	R/W-0	R/W-0	R/W-0	R/W-0	R/W-0	R/W-1	R/W-1
EXTR	SWR	SWDTEN ⁽²⁾	WDTO	SLEEP	IDLE	BOR	POR
bit 7						bit 0	

Legend:

R = Readable bit W = Writable bit U = Unimplemented bit, read as '0'
 -n = Value at POR '1' = Bit is set '0' = Bit is cleared x = Bit is unknown

- bit 15 **TRAPR:** Trap Reset Flag bit
 1 = A Trap Conflict Reset has occurred
 0 = A Trap Conflict Reset has not occurred
- bit 14 **IOPUWR:** Illegal Opcode or Uninitialized W Access Reset Flag bit
 1 = An illegal opcode detection, an illegal address mode or Uninitialized W register used as an Address Pointer caused a Reset
 0 = An illegal opcode or Uninitialized W register Reset has not occurred
- bit 13-10 **Unimplemented:** Read as '0'
- bit 9 **CM:** Configuration Mismatch Flag bit
 1 = A Configuration Mismatch Reset has occurred
 0 = A Configuration Mismatch Reset has NOT occurred
- bit 8 **VREGS:** Voltage Regulator Standby During Sleep bit
 1 = Voltage regulator is active during Sleep
 0 = Voltage regulator goes into Standby mode during Sleep
- bit 7 **EXTR:** External Reset Pin ($\overline{\text{MCLR}}$) bit
 1 = A Master Clear (pin) Reset has occurred
 0 = A Master Clear (pin) Reset has not occurred
- bit 6 **SWR:** Software Reset Flag (Instruction) bit
 1 = A **RESET** instruction has been executed
 0 = A **RESET** instruction has not been executed
- bit 5 **SWDTEN:** Software Enable/Disable of WDT bit⁽²⁾
 1 = WDT is enabled
 0 = WDT is disabled
- bit 4 **WDTO:** Watchdog Timer Time-out Flag bit
 1 = WDT time-out has occurred
 0 = WDT time-out has not occurred
- bit 3 **SLEEP:** Wake-up from Sleep Flag bit
 1 = Device has been in Sleep mode
 0 = Device has not been in Sleep mode
- bit 2 **IDLE:** Wake-up from Idle Flag bit
 1 = Device was in Idle mode
 0 = Device was not in Idle mode

Note 1: All of the Reset status bits can be set or cleared in software. Setting one of these bits in software does not cause a device Reset.

2: If the **FWDTEN** Configuration bit is '1' (unprogrammed), the WDT is always enabled, regardless of the **SWDTEN** bit setting.

dsPIC33FJ06GS101/X02 and dsPIC33FJ16GSX02/X04

REGISTER 6-1: RCON: RESET CONTROL REGISTER⁽¹⁾ (CONTINUED)

- bit 1 **BOR:** Brown-out Reset Flag bit
 1 = A Brown-out Reset has occurred
 0 = A Brown-out Reset has not occurred
- bit 0 **POR:** Power-on Reset Flag bit
 1 = A Power-on Reset has occurred
 0 = A Power-on Reset has not occurred

- Note 1:** All of the Reset status bits can be set or cleared in software. Setting one of these bits in software does not cause a device Reset.
- 2:** If the FWDTEN Configuration bit is '1' (unprogrammed), the WDT is always enabled, regardless of the SWDTEN bit setting.

dsPIC33FJ06GS101/X02 and dsPIC33FJ16GSX02/X04

6.1 System Reset

The dsPIC33FJ06GS101/X02 and dsPIC33FJ16GSX02/X04 families of devices have two types of Reset:

- Cold Reset
- Warm Reset

A Cold Reset is the result of a Power-on Reset (POR) or a Brown-out Reset (BOR). On a Cold Reset, the FNOSC_x Configuration bits in the FOSC Configuration register select the device clock source.

A Warm Reset is the result of all the other Reset sources, including the RESET instruction. On Warm Reset, the device will continue to operate from the current clock source as indicated by the Current Oscillator Selection (COSC<2:0>) bits in the Oscillator Control (OSCCON<14:12>) register.

The device is kept in a Reset state until the system power supplies have stabilized at appropriate levels and the oscillator clock is ready. The sequence in which this occurs is detailed in [Figure 6-2](#).

TABLE 6-1: OSCILLATOR DELAY

Oscillator Mode	Oscillator Startup Delay	Oscillator Startup Timer	PLL Lock Time	Total Delay
FRC, FRCDIV16, FRCDIVN	T _{OSCD} ⁽¹⁾	—	—	T _{OSCD} ⁽¹⁾
FRCPLL	T _{OSCD} ⁽¹⁾	—	T _{LOCK} ⁽³⁾	T _{OSCD} + T _{LOCK} ^(1,3)
XT	T _{OSCD} ⁽¹⁾	T _{OST} ⁽²⁾	—	T _{OSCD} + T _{OST} ^(1,2)
HS	T _{OSCD} ⁽¹⁾	T _{OST} ⁽²⁾	—	T _{OSCD} + T _{OST} ^(1,2)
EC	—	—	—	—
XTPLL	T _{OSCD} ⁽¹⁾	T _{OST} ⁽²⁾	T _{LOCK} ⁽³⁾	T _{OSCD} + T _{OST} + T _{LOCK} ^(1,2,3)
HSPLL	T _{OSCD} ⁽¹⁾	T _{OST} ⁽²⁾	T _{LOCK} ⁽³⁾	T _{OSCD} + T _{OST} + T _{LOCK} ^(1,2,3)
ECPLL	—	—	T _{LOCK} ⁽³⁾	T _{LOCK} ⁽³⁾
LPRC	T _{OSCD} ⁽¹⁾	—	—	T _{OSCD} ⁽¹⁾

- Note 1:** T_{OSCD} = Oscillator start-up delay (1.1 μs max for FRC, 70 μs max for LPRC). Crystal oscillator start-up times vary with crystal characteristics, load capacitance, etc.
- 2:** T_{OST} = Oscillator Start-up Timer delay (1024 oscillator clock period). For example, T_{OST} = 102.4 μs for a 10 MHz crystal and T_{OST} = 32 ms for a 32 kHz crystal.
- 3:** T_{LOCK} = PLL lock time (1.5 ms nominal) if PLL is enabled.

dsPIC33FJ06GS101/X02 and dsPIC33FJ16GSX02/X04

FIGURE 6-2: SYSTEM RESET TIMING



TABLE 6-2: OSCILLATOR DELAY

Symbol	Parameter	Value
VPOR	POR Threshold	1.8V nominal
TPOR	POR Extension Time	30 μ s maximum
VBOR	BOR Threshold	2.5V nominal
TBOR	BOR Extension Time	100 μ s maximum
TPWRT	Programmable Power-up Time Delay	0-128 ms nominal
TFSCM	Fail-Safe Clock Monitor Delay	900 μ s maximum

Note: When the device exits the Reset condition (begins normal operation), the device operating parameters (voltage, frequency, temperature, etc.) must be within their operating ranges; otherwise, the device may not function correctly. The user application must ensure that the delay between the time power is first applied, and the time SYSRST becomes inactive, is long enough to get all operating parameters within specification.

dsPIC33FJ06GS101/X02 and dsPIC33FJ16GSX02/X04

6.2 Power-on Reset (POR)

A Power-on Reset (POR) circuit ensures the device is reset from power-on. The POR circuit is active until VDD crosses the VPOR threshold and the delay, TPOR, has elapsed. The delay, TPOR, ensures the internal device bias circuits become stable.

The device supply voltage characteristics must meet the specified starting voltage and rise rate requirements to generate the POR. Refer to [Section 24.0 “Electrical Characteristics”](#) for details.

The POR status (POR) bit in the Reset Control (RCON<0>) register is set to indicate the Power-on Reset.

6.2.1 Brown-out Reset (BOR) and Power-up Timer (PWRT)

The on-chip regulator has a Brown-out Reset (BOR) circuit that resets the device when the VDD is too low ($VDD < VBOR$) for proper device operation. The BOR circuit keeps the device in Reset until VDD crosses the

VBOR threshold and the delay, TBOR, has elapsed. The delay, TBOR, ensures the voltage regulator output becomes stable.

The BOR status (BOR) bit in the Reset Control (RCON<1>) register is set to indicate the Brown-out Reset.

The device will not run at full speed after a BOR as the VDD should rise to acceptable levels for full-speed operation. The PWRT provides power-up time delay (TPWRT) to ensure that the system power supplies have stabilized at the appropriate levels for full-speed operation before the SYSRST is released.

The Power-up Timer Delay (TPWRT) is programmed by the Power-on Reset Timer Value Select (FPWRT<2:0>) bits in the FPOR Configuration (FPOR<2:0>) register, which provides eight settings (from 0 ms to 128 ms). Refer to [Section 21.0 “Special Features”](#) for further details.

[Figure 6-3](#) shows the typical brown-out scenarios. The Reset delay (TBOR + TPWRT) is initiated each time VDD rises above the VBOR trip point.

FIGURE 6-3: BROWN-OUT SITUATIONS



6.3 External Reset (EXTR)

The External Reset is generated by driving the $\overline{\text{MCLR}}$ pin low. The $\overline{\text{MCLR}}$ pin is a Schmitt trigger input with an additional glitch filter. Reset pulses that are longer than the minimum pulse width will generate a Reset. Refer to [Section 24.0 “Electrical Characteristics”](#) for minimum pulse width specifications. The External Reset ($\overline{\text{MCLR}}$) pin (EXTR) bit in the Reset Control (RCON) register is set to indicate the $\overline{\text{MCLR}}$ Reset.

6.3.0.1 EXTERNAL SUPERVISORY CIRCUIT

Many systems have external supervisory circuits that generate Reset signals to reset multiple devices in the system. This External Reset signal can be directly connected to the $\overline{\text{MCLR}}$ pin to reset the device when the rest of the system is reset.

6.3.0.2 INTERNAL SUPERVISORY CIRCUIT

When using the internal power supervisory circuit to reset the device, the External Reset pin ($\overline{\text{MCLR}}$) should be tied directly or resistively to VDD. In this case, the $\overline{\text{MCLR}}$ pin will not be used to generate a Reset. The External Reset pin ($\overline{\text{MCLR}}$) does not have an internal pull-up and must not be left unconnected.

6.4 Software RESET Instruction (SWR)

Whenever the `RESET` instruction is executed, the device will assert $\overline{\text{SYSRST}}$, placing the device in a special Reset state. This Reset state will not re-initialize the clock. The clock source in effect prior to the `RESET` instruction will remain. $\overline{\text{SYSRST}}$ is released at the next instruction cycle and the Reset vector fetch will commence.

The Software Reset (SWR) flag (instruction) in the Reset Control (RCON<6>) register is set to indicate the Software Reset.

6.5 Watchdog Timer Time-out Reset (WDTO)

Whenever a Watchdog time-out occurs, the device will asynchronously assert $\overline{\text{SYSRST}}$. The clock source will remain unchanged. A WDT time-out during Sleep or Idle mode will wake-up the processor, but will not reset the processor.

The Watchdog Timer Time-out (WDTO) flag in the Reset Control (RCON<4>) register is set to indicate the Watchdog Timer Reset. Refer to [Section 21.4 “Watchdog Timer \(WDT\)”](#) for more information on the Watchdog Timer Reset.

6.6 Trap Conflict Reset

If a lower priority hard trap occurs while a higher priority trap is being processed, a hard Trap Conflict Reset occurs. The hard traps include exceptions of Priority Levels 13 through 15, inclusive. The address error (Level 13) and oscillator error (Level 14) traps fall into this category.

The Trap Reset (TRAPR) flag in the Reset Control (RCON<15>) register is set to indicate the Trap Conflict Reset. Refer to [Section 7.0 “Interrupt Controller”](#) for more information on Trap Conflict Resets.

6.7 Configuration Mismatch Reset

To maintain the integrity of the Peripheral Pin Select Control registers, they are constantly monitored with shadow registers in hardware. If an unexpected change in any of the registers occur (such as cell disturbances caused by ESD or other external events), a Configuration Mismatch Reset occurs.

The Configuration Mismatch (CM) flag in the Reset Control (RCON<9>) register is set to indicate the Configuration Mismatch Reset. Refer to [Section 10.0 “I/O Ports”](#) for more information on the Configuration Mismatch Reset.

Note: The Configuration Mismatch Reset feature and associated Reset flag are not available on all devices.

6.8 Illegal Condition Device Reset

An illegal condition device Reset occurs due to the following sources:

- Illegal Opcode Reset
- Uninitialized W Register Reset
- Security Reset

The Illegal Opcode or Uninitialized W Access Reset (IOPUWR) flag in the Reset Control (RCON<14>) register is set to indicate the illegal condition device Reset.

6.8.1 ILLEGAL OPCODE RESET

A device Reset is generated if the device attempts to execute an illegal opcode value that is fetched from program memory.

The Illegal Opcode Reset function can prevent the device from executing program memory sections that are used to store constant data. To take advantage of the Illegal Opcode Reset, use only the lower 16 bits of each program memory section to store the data values. The upper 8 bits should be programmed with 3Fh, which is an illegal opcode value.

dsPIC33FJ06GS101/X02 and dsPIC33FJ16GSX02/X04

6.8.2 UNINITIALIZED W REGISTER RESET

Any attempt to use the Uninitialized W register as an Address Pointer will reset the device. The W register array (with the exception of W15) is cleared during all Resets and is considered uninitialized until written to.

6.8.3 SECURITY RESET

If a Program Flow Change (PFC) or Vector Flow Change (VFC) targets a restricted location in a protected segment (boot and secure segment), that operation will cause a Security Reset.

The PFC occurs when the Program Counter is reloaded as a result of a call, jump, computed jump, return, return from subroutine or other form of branch instruction.

The VFC occurs when the Program Counter is reloaded with an interrupt or trap vector.

Refer to [Section 21.8 “Code Protection and CodeGuard™ Security”](#) for more information on Security Reset.

6.9 Using the RCON Status Bits

The user application can read the Reset Control (RCON) register after any device Reset to determine the cause of the Reset.

Note: The status bits in the RCON register should be cleared after they are read so that the next RCON register value after a device Reset will be meaningful.

[Table 6-3](#) provides a summary of the Reset flag bit operation.

TABLE 6-3: RESET FLAG BIT OPERATION

Flag Bit	Set by:	Cleared by:
TRAPR (RCON<15>)	Trap conflict event	POR, BOR
IOPWR (RCON<14>)	Illegal opcode or Uninitialized W register access or Security Reset	POR, BOR
CM (RCON<9>)	Configuration Mismatch	POR, BOR
EXTR (RCON<7>)	MCLR Reset	POR
SWR (RCON<6>)	RESET instruction	POR, BOR
WDTO (RCON<4>)	WDT time-out	PWRSV instruction, CLRWDT instruction, POR, BOR
SLEEP (RCON<3>)	PWRSV #SLEEP instruction	POR, BOR
IDLE (RCON<2>)	PWRSV #IDLE instruction	POR, BOR
BOR (RCON<1>)	POR, BOR	—
POR (RCON<0>)	POR	—

Note: All Reset flag bits can be set or cleared by user software.

7.0 INTERRUPT CONTROLLER

Note 1: This data sheet summarizes the features of the dsPIC33FJ06GS101/X02 and dsPIC33FJ16GSX02/X04 families of devices. It is not intended to be a comprehensive reference source. To complement the information in this data sheet, refer to “**Interrupts (Part IV)**” (DS70300) in the “*dsPIC33F/PIC24H Family Reference Manual*”, which is available on the Microchip web site (www.microchip.com).

2: Some registers and associated bits described in this section may not be available on all devices. Refer to **Section 4.0 “Memory Organization”** in this data sheet for device-specific register and bit information.

The dsPIC33FJ06GS101/X02 and dsPIC33FJ16GSX02/X04 interrupt controller reduces the numerous peripheral interrupt request signals to a single interrupt request signal to the dsPIC33FJ06GS101/X02 and dsPIC33FJ16GSX02/X04 CPU. It has the following features:

- Up to eight processor exceptions and software traps
- Seven user-selectable priority levels
- Interrupt Vector Table (IVT) with up to 118 vectors
- A unique vector for each interrupt or exception source
- Fixed priority within a specified user priority level
- Alternate Interrupt Vector Table (AIVT) for debug support
- Fixed interrupt entry and return latencies

7.1 Interrupt Vector Table

The Interrupt Vector Table (IVT) is shown in [Figure 7-1](#). The IVT resides in program memory, starting at location 000004h. The IVT contains 126 vectors, consisting of eight nonmaskable trap vectors, plus up to 118 sources of interrupt. In general, each interrupt source has its own vector. Each interrupt vector contains a 24-bit-wide address. The value programmed into each interrupt vector location is the starting address of the associated Interrupt Service Routine (ISR).

Interrupt vectors are prioritized in terms of their natural priority. This priority is linked to their position in the vector table. Lower addresses generally have a higher natural priority. For example, the interrupt associated with Vector 0 will take priority over interrupts at any other vector address.

The dsPIC33FJ06GS101/X02 and dsPIC33FJ16GSX02/X04 devices implement up to 35 unique interrupts and 4 non-maskable traps. These are summarized in [Table 7-1](#).

7.1.1 ALTERNATE INTERRUPT VECTOR TABLE

The Alternate Interrupt Vector Table (AIVT) is located after the IVT, as shown in [Figure 7-1](#). Access to the AIVT is provided by the ALTIVT control bit (INTCON2<15>). If the ALTIVT bit is set, all interrupt and exception processes use the alternate vectors instead of the default vectors. The alternate vectors are organized in the same manner as the default vectors.

The AIVT supports debugging by providing a means to switch between an application and a support environment without requiring the interrupt vectors to be reprogrammed. This feature also enables switching between applications for evaluation of different software algorithms at run time. If the AIVT is not needed, the AIVT should be programmed with the same addresses used in the IVT.

7.2 Reset Sequence

A device Reset is not a true exception because the interrupt controller is not involved in the Reset process. The dsPIC33FJ06GS101/X02 and dsPIC33FJ16GSX02/X04 devices clear their registers in response to a Reset, which forces the PC to zero. The Digital Signal Controller then begins program execution at location, 0x000000. A GOTO instruction at the Reset address can redirect program execution to the appropriate start-up routine.

Note: Any unimplemented or unused vector locations in the IVT and AIVT should be programmed with the address of a default interrupt handler routine that contains a RESET instruction.

dsPIC33FJ06GS101/X02 and dsPIC33FJ16GSX02/X04

FIGURE 7-1: dsPIC33FJ06GS101/X02 and dsPIC33FJ16GSX02/X04 INTERRUPT VECTOR TABLE



dsPIC33FJ06GS101/X02 and dsPIC33FJ16GSX02/X04

TABLE 7-1: INTERRUPT VECTORS

Vector Number	Interrupt Request (IQR)	IVT Address	AIVT Address	Interrupt Source
Highest Natural Order Priority				
8	0	0x000014	0x000114	INT0 – External Interrupt 0
9	1	0x000016	0x000116	IC1 – Input Capture 1
10	2	0x000018	0x000118	OC1 – Output Compare 1
11	3	0x00001A	0x00011A	T1 – Timer1
12	4	0x00001C	0x00011C	Reserved
13	5	0x00001E	0x00011E	IC2 – Input Capture 2
14	6	0x000020	0x000120	OC2 – Output Compare 2
15	7	0x000022	0x000122	T2 – Timer2
16	8	0x000024	0x000124	T3 – Timer3
17	9	0x000026	0x000126	SPI1E – SPI1 Fault
18	10	0x000028	0x000128	SPI1 – SPI1 Transfer Done
19	11	0x00002A	0x00012A	U1RX – UART1 Receiver
20	12	0x00002C	0x00012C	U1TX – UART1 Transmitter
21	13	0x00002E	0x00012E	ADC – ADC Group Convert Done
22-23	14-15	0x000030-0x000032	0x000130-0x000132	Reserved
24	16	0x000034	0x000134	SI2C1 – I2C1 Slave Event
25	17	0x000036	0x000136	MI2C1 – I2C1 Master Event
26	18	0x000038	0x000138	CMP1 – Analog Comparator 1 Interrupt
27	19	0x00003A	0x00013A	CN – Input Change Notification Interrupt
28	20	0x00003C	0x00013C	INT1 – External Interrupt 1
29-36	21-28	0x00003E-0x00004C	0x00013E-0x00014C	Reserved
37	29	0x00004E	0x00014E	INT2 – External Interrupt 2
38-64	30-56	0x000050-0x000084	0x000150-0x000184	Reserved
65	57	0x000086	0x000186	PWM PSEM Special Event Match
66-72	58-64	0x000088-0x000094	0x000188-0x000194	Reserved
73	65	0x000096	0x000196	U1E – UART1 Error Interrupt
74-101	66-93	0x000098-0x0000CE	0x000198-0x0001CE	Reserved
102	94	0x0000D0	0x0001D0	PWM1 – PWM1 Interrupt
103	95	0x0000D2	0x0001D2	PWM2 – PWM2 Interrupt
104	96	0x0000D4	0x0001D4	PWM3 – PWM3 Interrupt
105	97	0x0000D6	0x0001D6	PWM4 – PWM4 Interrupt
106-110	98-102	0x0000D8-0x0000E0	0x0001D8-0x0001E0	Reserved
111	103	0x0000E2	0x0001E2	CMP2 – Analog Comparator 2
112	104	0x0000E4	0x0001E4	CMP3 – Analog Comparator 3
113	105	0x0000E6	0x0001E6	CMP4 – Analog Comparator 4
114-117	106-109	0x0000E8-0x0000EE	0x0001E8-0x0001EE	Reserved
118	110	0x0000F0	0x0001F0	ADC Pair 0 Convert Done
119	111	0x0000F2	0x0001F2	ADC Pair 1 Convert Done
120	112	0x0000F4	0x0001F4	ADC Pair 2 Convert Done
121	113	0x0000F6	0x0001F6	ADC Pair 3 Convert Done
122	114	0x0000F8	0x0001F8	ADC Pair 4 Convert Done
123	115	0x0000FA	0x0001FA	ADC Pair 5 Convert Done
124	116	0x0000FC	0x0001FC	ADC Pair 6 Convert Done
125	117	0x0000FE	0x0001FE	Reserved
Lowest Natural Order Priority				

dsPIC33FJ06GS101/X02 and dsPIC33FJ16GSX02/X04

7.3 Interrupt Control and Status Registers

The dsPIC33FJ06GS101/X02 and dsPIC33FJ16GSX02/X04 devices implement 27 registers for the interrupt controller:

- INTCON1
- INTCON2
- IFSx
- IECx
- IPCx
- INTTREG

7.3.1 INTCON1 AND INTCON2

Global interrupt control functions are controlled from INTCON1 and INTCON2. INTCON1 contains the Interrupt Nesting Disable (NSTDIS) bit as well as the control and status flags for the processor trap sources. The INTCON2 register controls the external interrupt request signal behavior and the use of the Alternate Interrupt Vector Table.

7.3.2 IFSx

The IFSx registers maintain all of the interrupt request flags. Each source of interrupt has a status bit, which is set by the respective peripherals or external signal and is cleared via software.

7.3.3 IECx

The IECx registers maintain all of the interrupt enable bits. These control bits are used to individually enable interrupts from the peripherals or external signals.

7.3.4 IPCx

The IPCx registers are used to set the Interrupt Priority Level for each source of interrupt. Each user interrupt source can be assigned to one of eight priority levels.

7.3.5 INTTREG

The INTTREG register contains the associated interrupt vector number and the new CPU Interrupt Priority Level, which are latched into the Vector Number (VECNUM<6:0>) and Interrupt Level (ILR<3:0>) bit fields in the INTTREG register. The new Interrupt Priority Level is the priority of the pending interrupt.

The interrupt sources are assigned to the IFSx, IECx and IPCx registers in the same sequence that they are listed in [Table 7-1](#). For example, the INT0 (External Interrupt 0) is shown as having Vector Number 8 and a natural order priority of 0. Thus, the INT0IF bit is found in IFS0<0>, the INT0IE bit is found in IEC0<0> and the INT0IP bits are found in the first position of IPC0 (IPC0<2:0>).

7.3.6 STATUS/CONTROL REGISTERS

Although they are not specifically part of the interrupt control hardware, two of the CPU Control registers contain bits that control interrupt functionality.

- The CPU STATUS Register, SR, contains the IPL<2:0> bits (SR<7:5>). These bits indicate the current CPU Interrupt Priority Level. The user can change the current CPU priority level by writing to the IPL bits.
- The CORCON register contains the IPL3 bit, which together with IPL<2:0>, indicates the current CPU priority level. IPL3 is a read-only bit so that trap events cannot be masked by the user software.

All Interrupt registers are described in [Register 7-1](#) through [Register 7-35](#) in the following pages.

dsPIC33FJ06GS101/X02 and dsPIC33FJ16GSX02/X04

REGISTER 7-1: SR: CPU STATUS REGISTER⁽¹⁾

R-0	R-0	R/C-0	R/C-0	R-0	R/C-0	R-0	R/W-0
OA	OB	SA	SB	OAB	SAB	DA	DC
bit 15							bit 8

R/W-0 ⁽³⁾	R/W-0 ⁽³⁾	R/W-0 ⁽³⁾	R-0	R/W-0	R/W-0	R/W-0	R/W-0
IPL2 ⁽²⁾	IPL1 ⁽²⁾	IPL0 ⁽²⁾	RA	N	OV	Z	C
bit 7							bit 0

Legend:	C = Clearable bit
R = Readable bit	W = Writable bit
-n = Value at POR	'1' = Bit is set
	'0' = Bit is cleared
	x = Bit is unknown
	U = Unimplemented bit, read as '0'

bit 7-5 **IPL<2:0>**: CPU Interrupt Priority Level Status bits^(2,3)

111 = CPU Interrupt Priority Level is 7 (15), user interrupts disabled
 110 = CPU Interrupt Priority Level is 6 (14)
 101 = CPU Interrupt Priority Level is 5 (13)
 100 = CPU Interrupt Priority Level is 4 (12)
 011 = CPU Interrupt Priority Level is 3 (11)
 010 = CPU Interrupt Priority Level is 2 (10)
 001 = CPU Interrupt Priority Level is 1 (9)
 000 = CPU Interrupt Priority Level is 0 (8)

- Note 1:** For complete register details, see [Register 3-1](#).
- 2:** The IPL<2:0> bits are concatenated with the IPL<3> bit (CORCON<3>) to form the CPU Interrupt Priority Level. The value in parentheses indicates the IPL if IPL<3> = 1. User interrupts are disabled when IPL<3> = 1.
- 3:** The IPL<2:0> status bits are read-only when NSTDIS (INTCON1<15>) = 1.

REGISTER 7-2: CORCON: CORE CONTROL REGISTER⁽¹⁾

U-0	U-0	U-0	R/W-0	R/W-0	R-0	R-0	R-0
—	—	—	US	EDT	DL2	DL1	DL0
bit 15							bit 8

R/W-0	R/W-0	R/W-1	R/W-0	R/C-0	R/W-0	R/W-0	R/W-0
SATA	SATB	SATDW	ACCSAT	IPL3 ⁽²⁾	PSV	RND	IF
bit 7							bit 0

Legend:	C = Clearable bit
R = Readable bit	W = Writable bit
'0' = Bit is cleared	'x' = Bit is unknown
	-n = Value at POR
	'1' = Bit is set
	U = Unimplemented bit, read as '0'

bit 3 **IPL3**: CPU Interrupt Priority Level Status bit⁽²⁾

1 = CPU Interrupt Priority Level is greater than 7
 0 = CPU Interrupt Priority Level is 7 or less

- Note 1:** For complete register details, see [Register 3-2](#).
- 2:** The IPL3 bit is concatenated with the IPL<2:0> bits (SR<7:5>) to form the CPU Interrupt Priority Level.

dsPIC33FJ06GS101/X02 and dsPIC33FJ16GSX02/X04

REGISTER 7-3: INTCON1: INTERRUPT CONTROL REGISTER 1

R/W-0	R/W-0	R/W-0	R/W-0	R/W-0	R/W-0	R/W-0	R/W-0
NSTDIS	OVAERR	OVBERR	COVAERR	COVBERR	OVATE	OVBTE	COVTE
bit 15							bit 8

R/W-0	R/W-0	U-0	R/W-0	R/W-0	R/W-0	R/W-0	U-0
SFTACERR	DIV0ERR	—	MATHERR	ADDRERR	STKERR	OSCFAIL	—
bit 7							bit 0

Legend:

R = Readable bit W = Writable bit U = Unimplemented bit, read as '0'
 -n = Value at POR '1' = Bit is set '0' = Bit is cleared x = Bit is unknown

- bit 15 **NSTDIS:** Interrupt Nesting Disable bit
 1 = Interrupt nesting is disabled
 0 = Interrupt nesting is enabled
- bit 14 **OVAERR:** Accumulator A Overflow Trap Flag bit
 1 = Trap was caused by overflow of Accumulator A
 0 = Trap was not caused by overflow of Accumulator A
- bit 13 **OVBERR:** Accumulator B Overflow Trap Flag bit
 1 = Trap was caused by overflow of Accumulator B
 0 = Trap was not caused by overflow of Accumulator B
- bit 12 **COVAERR:** Accumulator A Catastrophic Overflow Trap Flag bit
 1 = Trap was caused by catastrophic overflow of Accumulator A
 0 = Trap was not caused by catastrophic overflow of Accumulator A
- bit 11 **COVBERR:** Accumulator B Catastrophic Overflow Trap Flag bit
 1 = Trap was caused by catastrophic overflow of Accumulator B
 0 = Trap was not caused by catastrophic overflow of Accumulator B
- bit 10 **OVATE:** Accumulator A Overflow Trap Enable bit
 1 = Trap overflow of Accumulator A
 0 = Trap is disabled
- bit 9 **OVBTE:** Accumulator B Overflow Trap Enable bit
 1 = Trap overflow of Accumulator B
 0 = Trap is disabled
- bit 8 **COVTE:** Catastrophic Overflow Trap Enable bit
 1 = Trap on catastrophic overflow of Accumulator A or B enabled
 0 = Trap is disabled
- bit 7 **SFTACERR:** Shift Accumulator Error Status bit
 1 = Math error trap was caused by an invalid accumulator shift
 0 = Math error trap was not caused by an invalid accumulator shift
- bit 6 **DIV0ERR:** Arithmetic Error Status bit
 1 = Math error trap was caused by a divide-by-zero
 0 = Math error trap was not caused by a divide-by-zero
- bit 5 **Unimplemented:** Read as '0'
- bit 4 **MATHERR:** Arithmetic Error Status bit
 1 = Math error trap has occurred
 0 = Math error trap has not occurred
- bit 3 **ADDRERR:** Address Error Trap Status bit
 1 = Address error trap has occurred
 0 = Address error trap has not occurred

dsPIC33FJ06GS101/X02 and dsPIC33FJ16GSX02/X04

REGISTER 7-3: INTCON1: INTERRUPT CONTROL REGISTER 1 (CONTINUED)

- bit 2 **STKERR:** Stack Error Trap Status bit
 1 = Stack error trap has occurred
 0 = Stack error trap has not occurred
- bit 1 **OSCFAIL:** Oscillator Failure Trap Status bit
 1 = Oscillator failure trap has occurred
 0 = Oscillator failure trap has not occurred
- bit 0 **Unimplemented:** Read as '0'

dsPIC33FJ06GS101/X02 and dsPIC33FJ16GSX02/X04

REGISTER 7-4: INTCON2: INTERRUPT CONTROL REGISTER 2

R/W-0	R-0	U-0	U-0	U-0	U-0	U-0	U-0
ALTIVT	DISI	—	—	—	—	—	—
bit 15							bit 8

U-0	U-0	U-0	U-0	U-0	R/W-0	R/W-0	R/W-0
—	—	—	—	—	INT2EP	INT1EP	INT0EP
bit 7						bit 0	

Legend:

R = Readable bit W = Writable bit U = Unimplemented bit, read as '0'
 -n = Value at POR '1' = Bit is set '0' = Bit is cleared x = Bit is unknown

- bit 15 **ALTIVT:** Enable Alternate Interrupt Vector Table bit
 1 = Use alternate vector table
 0 = Use standard (default) vector table
- bit 14 **DISI:** DISI Instruction Status bit
 1 = DISI instruction is active
 0 = DISI instruction is not active
- bit 13-3 **Unimplemented:** Read as '0'
- bit 2 **INT2EP:** External Interrupt 2 Edge Detect Polarity Select bit
 1 = Interrupt on negative edge
 0 = Interrupt on positive edge
- bit 1 **INT1EP:** External Interrupt 1 Edge Detect Polarity Select bit
 1 = Interrupt on negative edge
 0 = Interrupt on positive edge
- bit 0 **INT0EP:** External Interrupt 0 Edge Detect Polarity Select bit
 1 = Interrupt on negative edge
 0 = Interrupt on positive edge

dsPIC33FJ06GS101/X02 and dsPIC33FJ16GSX02/X04

REGISTER 7-5: IFS0: INTERRUPT FLAG STATUS REGISTER 0

U-0	U-0	R/W-0	R/W-0	R/W-0	R/W-0	R/W-0	R/W-0
—	—	ADIF	U1TXIF	U1RXIF	SPI1IF	SPI1EIF	T3IF
bit 15							bit 8

R/W-0	R/W-0	R/W-0	U-0	R/W-0	R/W-0	R/W-0	R/W-0
T2IF	OC2IF	IC2IF	—	T1IF	OC1IF	IC1IF	INT0IF
bit 7							bit 0

Legend:

R = Readable bit W = Writable bit U = Unimplemented bit, read as '0'
-n = Value at POR '1' = Bit is set '0' = Bit is cleared x = Bit is unknown

- bit 15-14 **Unimplemented:** Read as '0'
- bit 13 **ADIF:** ADC Group Conversion Complete Interrupt Flag Status bit
1 = Interrupt request has occurred
0 = Interrupt request has not occurred
- bit 12 **U1TXIF:** UART1 Transmitter Interrupt Flag Status bit
1 = Interrupt request has occurred
0 = Interrupt request has not occurred
- bit 11 **U1RXIF:** UART1 Receiver Interrupt Flag Status bit
1 = Interrupt request has occurred
0 = Interrupt request has not occurred
- bit 10 **SPI1IF:** SPI1 Event Interrupt Flag Status bit
1 = Interrupt request has occurred
0 = Interrupt request has not occurred
- bit 9 **SPI1EIF:** SPI1 Fault Interrupt Flag Status bit
1 = Interrupt request has occurred
0 = Interrupt request has not occurred
- bit 8 **T3IF:** Timer3 Interrupt Flag Status bit
1 = Interrupt request has occurred
0 = Interrupt request has not occurred
- bit 7 **T2IF:** Timer2 Interrupt Flag Status bit
1 = Interrupt request has occurred
0 = Interrupt request has not occurred
- bit 6 **OC2IF:** Output Compare Channel 2 Interrupt Flag Status bit
1 = Interrupt request has occurred
0 = Interrupt request has not occurred
- bit 5 **IC2IF:** Input Capture Channel 2 Interrupt Flag Status bit
1 = Interrupt request has occurred
0 = Interrupt request has not occurred
- bit 4 **Unimplemented:** Read as '0'
- bit 3 **T1IF:** Timer1 Interrupt Flag Status bit
1 = Interrupt request has occurred
0 = Interrupt request has not occurred
- bit 2 **OC1IF:** Output Compare Channel 1 Interrupt Flag Status bit
1 = Interrupt request has occurred
0 = Interrupt request has not occurred

dsPIC33FJ06GS101/X02 and dsPIC33FJ16GSX02/X04

REGISTER 7-5: IFS0: INTERRUPT FLAG STATUS REGISTER 0 (CONTINUED)

bit 1 **IC1IF:** Input Capture Channel 1 Interrupt Flag Status bit

1 = Interrupt request has occurred

0 = Interrupt request has not occurred

bit 0 **INT0IF:** External Interrupt 0 Flag Status bit

1 = Interrupt request has occurred

0 = Interrupt request has not occurred

dsPIC33FJ06GS101/X02 and dsPIC33FJ16GSX02/X04

REGISTER 7-6: IFS1: INTERRUPT FLAG STATUS REGISTER 1

U-0	U-0	R/W-0	U-0	U-0	U-0	U-0	U-0
—	—	INT2IF	—	—	—	—	—
bit 15							bit 8

U-0	U-0	U-0	R/W-0	R/W-0	R/W-0	R/W-0	R/W-0
—	—	—	INT1IF	CNIF	AC1IF	MI2C1IF	SI2C1IF
bit 7							bit 0

Legend:

R = Readable bit W = Writable bit U = Unimplemented bit, read as '0'
 -n = Value at POR '1' = Bit is set '0' = Bit is cleared x = Bit is unknown

- bit 15-14 **Unimplemented:** Read as '0'
- bit 13 **INT2IF:** External Interrupt 2 Flag Status bit
 1 = Interrupt request has occurred
 0 = Interrupt request has not occurred
- bit 12-5 **Unimplemented:** Read as '0'
- bit 4 **INT1IF:** External Interrupt 1 Flag Status bit
 1 = Interrupt request has occurred
 0 = Interrupt request has not occurred
- bit 3 **CNIF:** Input Change Notification Interrupt Flag Status bit
 1 = Interrupt request has occurred
 0 = Interrupt request has not occurred
- bit 2 **AC1IF:** Analog Comparator 1 Interrupt Flag Status bit
 1 = Interrupt request has occurred
 0 = Interrupt request has not occurred
- bit 1 **MI2C1IF:** I2C1 Master Events Interrupt Flag Status bit
 1 = Interrupt request has occurred
 0 = Interrupt request has not occurred
- bit 0 **SI2C1IF:** I2C1 Slave Events Interrupt Flag Status bit
 1 = Interrupt request has occurred
 0 = Interrupt request has not occurred

dsPIC33FJ06GS101/X02 and dsPIC33FJ16GSX02/X04

REGISTER 7-7: IFS3: INTERRUPT FLAG STATUS REGISTER 3

U-0	U-0	U-0	U-0	U-0	U-0	R/W-0	U-0
—	—	—	—	—	—	PSEMIF	—
bit 15						bit 8	

U-0	U-0	U-0	U-0	U-0	U-0	U-0	U-0
—	—	—	—	—	—	—	—
bit 7						bit 0	

Legend:

R = Readable bit W = Writable bit U = Unimplemented bit, read as '0'
 -n = Value at POR '1' = Bit is set '0' = Bit is cleared x = Bit is unknown

- bit 15-10 **Unimplemented:** Read as '0'
- bit 9 **PSEMIF:** PWM Special Event Match Interrupt Flag Status bit
 1 = Interrupt request has occurred
 0 = Interrupt request has not occurred
- bit 8-0 **Unimplemented:** Read as '0'

REGISTER 7-8: IFS4: INTERRUPT FLAG STATUS REGISTER 4

U-0	U-0	U-0	U-0	U-0	U-0	U-0	U-0
—	—	—	—	—	—	—	—
bit 15						bit 8	

U-0	U-0	U-0	U-0	U-0	U-0	R/W-0	U-0
—	—	—	—	—	—	U1EIF	—
bit 7						bit 0	

Legend:

R = Readable bit W = Writable bit U = Unimplemented bit, read as '0'
 -n = Value at POR '1' = Bit is set '0' = Bit is cleared x = Bit is unknown

- bit 15-2 **Unimplemented:** Read as '0'
- bit 1 **U1EIF:** UART1 Error Interrupt Flag Status bit
 1 = Interrupt request has occurred
 0 = Interrupt request has not occurred
- bit 0 **Unimplemented:** Read as '0'

dsPIC33FJ06GS101/X02 and dsPIC33FJ16GSX02/X04

REGISTER 7-9: IFS5: INTERRUPT FLAG STATUS REGISTER 5

R/W-0	R/W-0	U-0	U-0	U-0	U-0	U-0	U-0
PWM2IF	PWM1IF	—	—	—	—	—	—
bit 15							bit 8

U-0	U-0	U-0	U-0	U-0	U-0	U-0	U-0
—	—	—	—	—	—	—	—
bit 7							bit 0

Legend:

R = Readable bit

W = Writable bit

U = Unimplemented bit, read as '0'

-n = Value at POR

'1' = Bit is set

'0' = Bit is cleared

x = Bit is unknown

bit 15 **PWM2IF:** PWM2 Interrupt Flag Status bit

1 = Interrupt request has occurred

0 = Interrupt request has not occurred

bit 14 **PWM1IF:** PWM1 Interrupt Flag Status bit

1 = Interrupt request has occurred

0 = Interrupt request has not occurred

bit 13-0 **Unimplemented:** Read as '0'

dsPIC33FJ06GS101/X02 and dsPIC33FJ16GSX02/X04

REGISTER 7-10: IFS6: INTERRUPT FLAG STATUS REGISTER 6

R/W-0	R/W-0	U-0	U-0	U-0	U-0	R/W-0	R/W-0
ADCP1IF	ADCP0IF	—	—	—	—	AC4IF	AC3IF
bit 15						bit 8	

R/W-0	U-0	U-0	U-0	U-0	U-0	R/W-0	R/W-0
AC2IF	—	—	—	—	—	PWM4IF	PWM3IF
bit 7						bit 0	

Legend:

R = Readable bit W = Writable bit U = Unimplemented bit, read as '0'
 -n = Value at POR '1' = Bit is set '0' = Bit is cleared x = Bit is unknown

- bit 15 **ADCP1IF:** ADC Pair 1 Conversion Done Interrupt Flag Status bit
 1 = Interrupt request has occurred
 0 = Interrupt request has not occurred
- bit 14 **ADCP0IF:** ADC Pair 0 Conversion Done Interrupt Flag Status bit
 1 = Interrupt request has occurred
 0 = Interrupt request has not occurred
- bit 13-10 **Unimplemented:** Read as '0'
- bit 9 **AC4IF:** Analog Comparator 4 Interrupt Flag Status bit
 1 = Interrupt request has occurred
 0 = Interrupt request has not occurred
- bit 8 **AC3IF:** Analog Comparator 3 Interrupt Flag Status bit
 1 = Interrupt request has occurred
 0 = Interrupt request has not occurred
- bit 7 **AC2IF:** Analog Comparator 2 Interrupt Flag Status bit
 1 = Interrupt request has occurred
 0 = Interrupt request has not occurred
- bit 6-2 **Unimplemented:** Read as '0'
- bit 1 **PWM4IF:** PWM4 Interrupt Flag Status bit
 1 = Interrupt request has occurred
 0 = Interrupt request has not occurred
- bit 0 **PWM3IF:** PWM3 Interrupt Flag Status bit
 1 = Interrupt request has occurred
 0 = Interrupt request has not occurred

dsPIC33FJ06GS101/X02 and dsPIC33FJ16GSX02/X04

REGISTER 7-11: IFS7: INTERRUPT FLAG STATUS REGISTER 7

U-0	U-0	U-0	U-0	U-0	U-0	U-0	U-0
—	—	—	—	—	—	—	—
bit 15							bit 8

U-0	U-0	U-0	R/W-0	R/W-0	R/W-0	R/W-0	R/W-0
—	—	—	ADCP6IF	ADCP5IF	ADCP4IF	ADCP3IF	ADCP2IF
bit 7							bit 0

Legend:

R = Readable bit W = Writable bit U = Unimplemented bit, read as '0'
 -n = Value at POR '1' = Bit is set '0' = Bit is cleared x = Bit is unknown

- bit 15-5 **Unimplemented:** Read as '0'
- bit 4 **ADCP6IF:** ADC Pair 6 Conversion Done Interrupt Flag Status bit
 1 = Interrupt request has occurred
 0 = Interrupt request has not occurred
- bit 3 **ADCP5IF:** ADC Pair 5 Conversion Done Interrupt Flag Status bit
 1 = Interrupt request has occurred
 0 = Interrupt request has not occurred
- bit 2 **ADCP4IF:** ADC Pair 4 Conversion Done Interrupt Flag Status bit
 1 = Interrupt request has occurred
 0 = Interrupt request has not occurred
- bit 1 **ADCP3IF:** ADC Pair 3 Conversion Done Interrupt Flag Status bit
 1 = Interrupt request has occurred
 0 = Interrupt request has not occurred
- bit 0 **ADCP2IF:** ADC Pair 2 Conversion Done Interrupt Flag Status bit
 1 = Interrupt request has occurred
 0 = Interrupt request has not occurred

dsPIC33FJ06GS101/X02 and dsPIC33FJ16GSX02/X04

REGISTER 7-12: IEC0: INTERRUPT ENABLE CONTROL REGISTER 0

U-0	U-0	R/W-0	R/W-0	R/W-0	R/W-0	R/W-0	R/W-0
—	—	ADIE	U1TXIE	U1RXIE	SPI1IE	SPI1EIE	T3IE
bit 15							bit 8

R/W-0	R/W-0	R/W-0	U-0	R/W-0	R/W-0	R/W-0	R/W-0
T2IE	OC2IE	IC2IE	—	T1IE	OC1IE	IC1IE	INT0IE
bit 7							bit 0

Legend:

R = Readable bit	W = Writable bit	U = Unimplemented bit, read as '0'
-n = Value at POR	'1' = Bit is set	'0' = Bit is cleared
		x = Bit is unknown

- bit 15-14 **Unimplemented:** Read as '0'
- bit 13 **ADIE:** ADC1 Conversion Complete Interrupt Enable bit
1 = Interrupt request enabled
0 = Interrupt request not enabled
- bit 12 **U1TXIE:** UART1 Transmitter Interrupt Enable bit
1 = Interrupt request enabled
0 = Interrupt request not enabled
- bit 11 **U1RXIE:** UART1 Receiver Interrupt Enable bit
1 = Interrupt request enabled
0 = Interrupt request not enabled
- bit 10 **SPI1IE:** SPI1 Event Interrupt Enable bit
1 = Interrupt request enabled
0 = Interrupt request not enabled
- bit 9 **SPI1EIE:** SPI1 Event Interrupt Enable bit
1 = Interrupt request enabled
0 = Interrupt request not enabled
- bit 8 **T3IE:** Timer3 Interrupt Enable bit
1 = Interrupt request enabled
0 = Interrupt request not enabled
- bit 7 **T2IE:** Timer2 Interrupt Enable bit
1 = Interrupt request enabled
0 = Interrupt request not enabled
- bit 6 **OC2IE:** Output Compare Channel 2 Interrupt Enable bit
1 = Interrupt request enabled
0 = Interrupt request not enabled
- bit 5 **IC2IE:** Input Capture Channel 2 Interrupt Enable bit
1 = Interrupt request enabled
0 = Interrupt request not enabled
- bit 4 **Unimplemented:** Read as '0'
- bit 3 **T1IE:** Timer1 Interrupt Enable bit
1 = Interrupt request enabled
0 = Interrupt request not enabled
- bit 2 **OC1IE:** Output Compare Channel 1 Interrupt Enable bit
1 = Interrupt request enabled
0 = Interrupt request not enabled

dsPIC33FJ06GS101/X02 and dsPIC33FJ16GSX02/X04

REGISTER 7-12: IEC0: INTERRUPT ENABLE CONTROL REGISTER 0 (CONTINUED)

- bit 1 **IC1IE:** Input Capture Channel 1 Interrupt Enable bit
 1 = Interrupt request enabled
 0 = Interrupt request not enabled
- bit 0 **INT0IE:** External Interrupt 0 Enable bit
 1 = Interrupt request enabled
 0 = Interrupt request not enabled

dsPIC33FJ06GS101/X02 and dsPIC33FJ16GSX02/X04

REGISTER 7-13: IEC1: INTERRUPT ENABLE CONTROL REGISTER 1

U-0	U-0	R/W-0	U-0	U-0	U-0	U-0	U-0
—	—	INT2IE	—	—	—	—	—
bit 15						bit 8	

U-0	U-0	U-0	R/W-0	R/W-0	R/W-0	R/W-0	R/W-0
—	—	—	INT1IE	CNIE	AC1IE	MI2C1IE	SI2C1IE
bit 7						bit 0	

Legend:

R = Readable bit

W = Writable bit

U = Unimplemented bit, read as '0'

-n = Value at POR

'1' = Bit is set

'0' = Bit is cleared

x = Bit is unknown

- bit 15-14 **Unimplemented:** Read as '0'
- bit 13 **INT2IE:** External Interrupt 2 Enable bit
 1 = Interrupt request enabled
 0 = Interrupt request not enabled
- bit 12-5 **Unimplemented:** Read as '0'
- bit 4 **INT1IE:** External Interrupt 1 Enable bit
 1 = Interrupt request enabled
 0 = Interrupt request not enabled
- bit 3 **CNIE:** Input Change Notification Interrupt Enable bit
 1 = Interrupt request enabled
 0 = Interrupt request not enabled
- bit 2 **AC1IE:** Analog Comparator 1 Interrupt Enable bit
 1 = Interrupt request enabled
 0 = Interrupt request not enabled
- bit 1 **MI2C1IE:** I2C1 Master Events Interrupt Enable bit
 1 = Interrupt request enabled
 0 = Interrupt request not enabled
- bit 0 **SI2C1IE:** I2C1 Slave Events Interrupt Enable bit
 1 = Interrupt request enabled
 0 = Interrupt request not enabled

dsPIC33FJ06GS101/X02 and dsPIC33FJ16GSX02/X04

REGISTER 7-14: IEC3: INTERRUPT ENABLE CONTROL REGISTER 3

U-0	U-0	U-0	U-0	U-0	U-0	R/W-0	U-0
—	—	—	—	—	—	PSEMIE	—
bit 15						bit 8	

U-0	U-0	U-0	U-0	U-0	U-0	U-0	U-0
—	—	—	—	—	—	—	—
bit 7						bit 0	

Legend:

R = Readable bit W = Writable bit U = Unimplemented bit, read as '0'
 -n = Value at POR '1' = Bit is set '0' = Bit is cleared x = Bit is unknown

bit 15-10 **Unimplemented:** Read as '0'
 bit 9 **PSEMIE:** PWM Special Event Match Interrupt Enable bit
 1 = Interrupt request enabled
 0 = Interrupt request not enabled
 bit 8-0 **Unimplemented:** Read as '0'

REGISTER 7-15: IEC4: INTERRUPT ENABLE CONTROL REGISTER 4

U-0	U-0	U-0	U-0	U-0	U-0	U-0	U-0
—	—	—	—	—	—	—	—
bit 15						bit 8	

U-0	U-0	U-0	U-0	U-0	U-0	R/W-0	U-0
—	—	—	—	—	—	U1EIE	—
bit 7						bit 0	

Legend:

R = Readable bit W = Writable bit U = Unimplemented bit, read as '0'
 -n = Value at POR '1' = Bit is set '0' = Bit is cleared x = Bit is unknown

bit 15-2 **Unimplemented:** Read as '0'
 bit 1 **U1EIE:** UART1 Error Interrupt Enable bit
 1 = Interrupt request enabled
 0 = Interrupt request not enabled
 bit 0 **Unimplemented:** Read as '0'

dsPIC33FJ06GS101/X02 and dsPIC33FJ16GSX02/X04

REGISTER 7-16: IEC5: INTERRUPT ENABLE CONTROL REGISTER 5

R/W-0	R/W-0	U-0	U-0	U-0	U-0	U-0	U-0
PWM2IE	PWM1IE	—	—	—	—	—	—
bit 15							bit 8

U-0	U-0	U-0	U-0	U-0	U-0	U-0	U-0
—	—	—	—	—	—	—	—
bit 7							bit 0

Legend:

R = Readable bit W = Writable bit U = Unimplemented bit, read as '0'
 -n = Value at POR '1' = Bit is set '0' = Bit is cleared x = Bit is unknown

- bit 15 **PWM2IE:** PWM2 Interrupt Enable bit
 1 = Interrupt request is enabled
 0 = Interrupt request is not enabled
- bit 14 **PWM1IE:** PWM1 Interrupt Enable bit
 1 = Interrupt request is enabled
 0 = Interrupt request is not enabled
- bit 13-0 **Unimplemented:** Read as '0'

dsPIC33FJ06GS101/X02 and dsPIC33FJ16GSX02/X04

REGISTER 7-17: IEC6: INTERRUPT ENABLE CONTROL REGISTER 6

R/W-0	R/W-0	U-0	U-0	U-0	U-0	R/W-0	R/W-0
ADCP1IE	ADCP0IE	—	—	—	—	AC4IE	AC3IE
bit 15						bit 8	

R/W-0	U-0	U-0	U-0	U-0	U-0	R/W-0	R/W-0
AC2IE	—	—	—	—	—	PWM4IE	PWM3IE
bit 7						bit 0	

Legend:

R = Readable bit W = Writable bit U = Unimplemented bit, read as '0'
 -n = Value at POR '1' = Bit is set '0' = Bit is cleared x = Bit is unknown

- bit 15 **ADCP1IE:** ADC Pair 1 Conversion Done Interrupt Enable bit
 1 = Interrupt request is enabled
 0 = Interrupt request is not enabled
- bit 14 **ADCP0IE:** ADC Pair 0 Conversion Done Interrupt Enable bit
 1 = Interrupt request is enabled
 0 = Interrupt request is not enabled
- bit 13-10 **Unimplemented:** Read as '0'
- bit 9 **AC4IE:** Analog Comparator 4 Interrupt Enable bit
 1 = Interrupt request is enabled
 0 = Interrupt request is not enabled
- bit 8 **AC3IE:** Analog Comparator 3 Interrupt Enable bit
 1 = Interrupt request is enabled
 0 = Interrupt request is not enabled
- bit 7 **AC2IE:** Analog Comparator 2 Interrupt Enable bit
 1 = Interrupt request is enabled
 0 = Interrupt request is not enabled
- bit 6-2 **Unimplemented:** Read as '0'
- bit 1 **PWM4IE:** PWM4 Interrupt Enable bit
 1 = Interrupt request is enabled
 0 = Interrupt request is not enabled
- bit 0 **PWM3IE:** PWM3 Interrupt Enable bit
 1 = Interrupt request is enabled
 0 = Interrupt request is not enabled

dsPIC33FJ06GS101/X02 and dsPIC33FJ16GSX02/X04

REGISTER 7-18: IEC7: INTERRUPT ENABLE CONTROL REGISTER 7

U-0	U-0	U-0	U-0	U-0	U-0	U-0	U-0
—	—	—	—	—	—	—	—
bit 15							bit 8

U-0	U-0	U-0	R/W-0	R/W-0	R/W-0	R/W-0	R/W-0
—	—	—	ADCP6IE	ADCP5IE	ADCP4IE	ADCP3IE	ADCP2IE
bit 7							bit 0

Legend:

R = Readable bit W = Writable bit U = Unimplemented bit, read as '0'
 -n = Value at POR '1' = Bit is set '0' = Bit is cleared x = Bit is unknown

- bit 15-5 **Unimplemented:** Read as '0'
- bit 4 **ADCP6IE:** ADC Pair 6 Conversion Done Interrupt Enable bit
 1 = Interrupt request is enabled
 0 = Interrupt request is not enabled
- bit 3 **ADCP5IE:** ADC Pair 5 Conversion Done Interrupt Enable bit
 1 = Interrupt request is enabled
 0 = Interrupt request is not enabled
- bit 2 **ADCP4IE:** ADC Pair 4 Conversion Done Interrupt Enable bit
 1 = Interrupt request is enabled
 0 = Interrupt request is not enabled
- bit 1 **ADCP3IE:** ADC Pair 3 Conversion Done Interrupt Enable bit
 1 = Interrupt request is enabled
 0 = Interrupt request is not enabled
- bit 0 **ADCP2IE:** ADC Pair 2 Conversion Done Interrupt Enable bit
 1 = Interrupt request is enabled
 0 = Interrupt request is not enabled

dsPIC33FJ06GS101/X02 and dsPIC33FJ16GSX02/X04

REGISTER 7-19: IPC0: INTERRUPT PRIORITY CONTROL REGISTER 0

U-0	R/W-1	R/W-0	R/W-0	U-0	R/W-1	R/W-0	R/W-0
—	T1IP2	T1IP1	T1IP0	—	OC1IP2	OC1IP1	OC1IP0
bit 15						bit 8	

U-0	R/W-1	R/W-0	R/W-0	U-0	R/W-1	R/W-0	R/W-0
—	IC1IP2	IC1IP1	IC1IP0	—	INT0IP2	INT0IP1	INT0IP0
bit 7						bit 0	

Legend:

R = Readable bit W = Writable bit U = Unimplemented bit, read as '0'
 -n = Value at POR '1' = Bit is set '0' = Bit is cleared x = Bit is unknown

- bit 15 **Unimplemented:** Read as '0'
- bit 14-12 **T1IP<2:0>:** Timer1 Interrupt Priority bits
 - 111 = Interrupt is Priority 7 (highest priority interrupt)
 -
 -
 -
 - 001 = Interrupt is Priority 1
 - 000 = Interrupt source is disabled
- bit 11 **Unimplemented:** Read as '0'
- bit 10-8 **OC1IP<2:0>:** Output Compare Channel 1 Interrupt Priority bits
 - 111 = Interrupt is Priority 7 (highest priority interrupt)
 -
 -
 -
 - 001 = Interrupt is Priority 1
 - 000 = Interrupt source is disabled
- bit 7 **Unimplemented:** Read as '0'
- bit 6-4 **IC1IP<2:0>:** Input Capture Channel 1 Interrupt Priority bits
 - 111 = Interrupt is Priority 7 (highest priority interrupt)
 -
 -
 -
 - 001 = Interrupt is Priority 1
 - 000 = Interrupt source is disabled
- bit 3 **Unimplemented:** Read as '0'
- bit 2-0 **INT0IP<2:0>:** External Interrupt 0 Priority bits
 - 111 = Interrupt is Priority 7 (highest priority interrupt)
 -
 -
 -
 - 001 = Interrupt is Priority 1
 - 000 = Interrupt source is disabled

dsPIC33FJ06GS101/X02 and dsPIC33FJ16GSX02/X04

REGISTER 7-20: IPC1: INTERRUPT PRIORITY CONTROL REGISTER 1

U-0	R/W-1	R/W-0	R/W-0	U-0	R/W-1	R/W-0	R/W-0
—	T2IP2	T2IP1	T2IP0	—	OC2IP2	OC2IP1	OC2IP0
bit 15							bit 8

U-0	R/W-1	R/W-0	R/W-0	U-0	U-0	U-0	U-0
—	IC2IP2	IC2IP1	IC2IP0	—	—	—	—
bit 7							bit 0

Legend:

R = Readable bit W = Writable bit U = Unimplemented bit, read as '0'
 -n = Value at POR '1' = Bit is set '0' = Bit is cleared x = Bit is unknown

- bit 15 **Unimplemented:** Read as '0'
- bit 14-12 **T2IP<2:0>:** Timer2 Interrupt Priority bits
 - 111 = Interrupt is Priority 7 (highest priority interrupt)
 -
 -
 -
 - 001 = Interrupt is Priority 1
 - 000 = Interrupt source is disabled
- bit 11 **Unimplemented:** Read as '0'
- bit 10-8 **OC2IP<2:0>:** Output Compare Channel 2 Interrupt Priority bits
 - 111 = Interrupt is Priority 7 (highest priority interrupt)
 -
 -
 -
 - 001 = Interrupt is Priority 1
 - 000 = Interrupt source is disabled
- bit 7 **Unimplemented:** Read as '0'
- bit 6-4 **IC2IP<2:0>:** Input Capture Channel 2 Interrupt Priority bits
 - 111 = Interrupt is Priority 7 (highest priority interrupt)
 -
 -
 -
 - 001 = Interrupt is Priority 1
 - 000 = Interrupt source is disabled
- bit 3-0 **Unimplemented:** Read as '0'

dsPIC33FJ06GS101/X02 and dsPIC33FJ16GSX02/X04

REGISTER 7-21: IPC2: INTERRUPT PRIORITY CONTROL REGISTER 2

U-0	R/W-1	R/W-0	R/W-0	U-0	R/W-1	R/W-0	R/W-0
—	U1RXIP2	U1RXIP1	U1RXIP0	—	SPI1IP2	SPI1IP1	SPI1IP0
bit 15						bit 8	

U-0	R/W-1	R/W-0	R/W-0	U-0	R/W-1	R/W-0	R/W-0
—	SPI1EIP2	SPI1EIP1	SPI1EIP0	—	T3IP2	T3IP1	T3IP0
bit 7						bit 0	

Legend:

R = Readable bit W = Writable bit U = Unimplemented bit, read as '0'
 -n = Value at POR '1' = Bit is set '0' = Bit is cleared x = Bit is unknown

- bit 15 **Unimplemented:** Read as '0'
- bit 14-12 **U1RXIP<2:0>:** UART1 Receiver Interrupt Priority bits
 - 111 = Interrupt is Priority 7 (highest priority interrupt)
 -
 -
 -
 - 001 = Interrupt is Priority 1
 - 000 = Interrupt source is disabled
- bit 11 **Unimplemented:** Read as '0'
- bit 10-8 **SPI1IP<2:0>:** SPI1 Event Interrupt Priority bits
 - 111 = Interrupt is Priority 7 (highest priority interrupt)
 -
 -
 -
 - 001 = Interrupt is Priority 1
 - 000 = Interrupt source is disabled
- bit 7 **Unimplemented:** Read as '0'
- bit 6-4 **SPI1EIP<2:0>:** SPI1 Error Interrupt Priority bits
 - 111 = Interrupt is Priority 7 (highest priority interrupt)
 -
 -
 -
 - 001 = Interrupt is Priority 1
 - 000 = Interrupt source is disabled
- bit 3 **Unimplemented:** Read as '0'
- bit 2-0 **T3IP<2:0>:** Timer3 Interrupt Priority bits
 - 111 = Interrupt is Priority 7 (highest priority interrupt)
 -
 -
 -
 - 001 = Interrupt is Priority 1
 - 000 = Interrupt source is disabled

dsPIC33FJ06GS101/X02 and dsPIC33FJ16GSX02/X04

REGISTER 7-22: IPC3: INTERRUPT PRIORITY CONTROL REGISTER 3

U-0	U-0	U-0	U-0	U-0	U-0	U-0	U-0
—	—	—	—	—	—	—	—
bit 15							bit 8

U-0	R/W-1	R/W-0	R/W-0	U-0	R/W-1	R/W-0	R/W-0
—	ADIP2	ADIP1	ADIP0	—	U1TXIP2	U1TXIP1	U1TXIP0
bit 7							bit 0

Legend:

R = Readable bit W = Writable bit U = Unimplemented bit, read as '0'
 -n = Value at POR '1' = Bit is set '0' = Bit is cleared x = Bit is unknown

- bit 15-7 **Unimplemented:** Read as '0'
- bit 6-4 **ADIP<2:0>:** ADC1 Conversion Complete Interrupt Priority bits
 - 111 = Interrupt is Priority 7 (highest priority interrupt)
 -
 -
 -
 - 001 = Interrupt is Priority 1
 - 000 = Interrupt source is disabled
- bit 3 **Unimplemented:** Read as '0'
- bit 2-0 **U1TXIP<2:0>:** UART1 Transmitter Interrupt Priority bits
 - 111 = Interrupt is Priority 7 (highest priority interrupt)
 -
 -
 -
 - 001 = Interrupt is Priority 1
 - 000 = Interrupt source is disabled

dsPIC33FJ06GS101/X02 and dsPIC33FJ16GSX02/X04

REGISTER 7-23: IPC4: INTERRUPT PRIORITY CONTROL REGISTER 4

U-0	R/W-1	R/W-0	R/W-0	U-0	R/W-1	R/W-0	R/W-0
—	CNIP2	CNIP1	CNIP0	—	AC1IP2	AC1IP1	AC1IP0
bit 15				bit 8			

U-0	R/W-1	R/W-0	R/W-0	U-0	R/W-1	R/W-0	R/W-0
—	MI2C1IP2	MI2C1IP1	MI2C1IP0	—	SI2C1IP2	SI2C1IP1	SI2C1IP0
bit 7				bit 0			

Legend:

R = Readable bit W = Writable bit U = Unimplemented bit, read as '0'
 -n = Value at POR '1' = Bit is set '0' = Bit is cleared x = Bit is unknown

- bit 15 **Unimplemented:** Read as '0'
- bit 14-12 **CNIP<2:0>:** Change Notification Interrupt Priority bits
 - 111 = Interrupt is Priority 7 (highest priority interrupt)
 -
 -
 -
 - 001 = Interrupt is Priority 1
 - 000 = Interrupt source is disabled
- bit 11 **Unimplemented:** Read as '0'
- bit 10-8 **AC1IP<2:0>:** Analog Comparator 1 Interrupt Priority bits
 - 111 = Interrupt is Priority 7 (highest priority interrupt)
 -
 -
 -
 - 001 = Interrupt is Priority 1
 - 000 = Interrupt source is disabled
- bit 7 **Unimplemented:** Read as '0'
- bit 6-4 **MI2C1IP<2:0>:** I2C1 Master Events Interrupt Priority bits
 - 111 = Interrupt is Priority 7 (highest priority interrupt)
 -
 -
 -
 - 001 = Interrupt is Priority 1
 - 000 = Interrupt source is disabled
- bit 3 **Unimplemented:** Read as '0'
- bit 2-0 **SI2C1IP<2:0>:** I2C1 Slave Events Interrupt Priority bits
 - 111 = Interrupt is Priority 7 (highest priority interrupt)
 -
 -
 -
 - 001 = Interrupt is Priority 1
 - 000 = Interrupt source is disabled

dsPIC33FJ06GS101/X02 and dsPIC33FJ16GSX02/X04

REGISTER 7-24: IPC5: INTERRUPT PRIORITY CONTROL REGISTER 5

U-0	U-0	U-0	U-0	U-0	U-0	U-0	U-0
—	—	—	—	—	—	—	—
bit 15							bit 8

U-0	U-0	U-0	U-0	U-0	R/W-1	R/W-0	R/W-0
—	—	—	—	—	INT1IP2	INT1IP1	INT1IP0
bit 7						bit 0	

Legend:

R = Readable bit W = Writable bit U = Unimplemented bit, read as '0'
 -n = Value at POR '1' = Bit is set '0' = Bit is cleared x = Bit is unknown

bit 15-3 **Unimplemented:** Read as '0'
 bit 2-0 **INT1IP<2:0>:** External Interrupt 1 Priority bits
 111 = Interrupt is Priority 7 (highest priority interrupt)
 •
 •
 •
 001 = Interrupt is Priority 1
 000 = Interrupt source is disabled

REGISTER 7-25: IPC7: INTERRUPT PRIORITY CONTROL REGISTER 7

U-0	U-0	U-0	U-0	U-0	U-0	U-0	U-0
—	—	—	—	—	—	—	—
bit 15							bit 8

U-0	R/W-1	R/W-0	R/W-0	U-0	U-0	U-0	U-0
—	INT2IP2	INT2IP1	INT2IP0	—	—	—	—
bit 7						bit 0	

Legend:

R = Readable bit W = Writable bit U = Unimplemented bit, read as '0'
 -n = Value at POR '1' = Bit is set '0' = Bit is cleared x = Bit is unknown

bit 15-7 **Unimplemented:** Read as '0'
 bit 6-4 **INT2IP<2:0>:** External Interrupt 2 Priority bits
 111 = Interrupt is Priority 7 (highest priority interrupt)
 •
 •
 •
 001 = Interrupt is Priority 1
 000 = Interrupt source is disabled
 bit 3-0 **Unimplemented:** Read as '0'

dsPIC33FJ06GS101/X02 and dsPIC33FJ16GSX02/X04

REGISTER 7-26: IPC14: INTERRUPT PRIORITY CONTROL REGISTER 14

U-0	U-0	U-0	U-0	U-0	U-0	U-0	U-0
—	—	—	—	—	—	—	—
bit 15							bit 8

U-0	R/W-1	R/W-0	R/W-0	U-0	U-0	U-0	U-0
—	PSEMIP2	PSEMIP1	PSEMIP0	—	—	—	—
bit 7							bit 0

Legend:			
R = Readable bit	W = Writable bit	U = Unimplemented bit, read as '0'	
-n = Value at POR	'1' = Bit is set	'0' = Bit is cleared	x = Bit is unknown

bit 15-7 **Unimplemented:** Read as '0'

bit 6-4 **PSEMIP<2:0>:** PWM Special Event Match Interrupt Priority bits
 111 = Interrupt is Priority 7 (highest priority interrupt)
 •
 •
 •
 001 = Interrupt is Priority 1
 000 = Interrupt source is disabled

bit 3-0 **Unimplemented:** Read as '0'

REGISTER 7-27: IPC16: INTERRUPT PRIORITY CONTROL REGISTER 16

U-0	U-0	U-0	U-0	U-0	U-0	U-0	U-0
—	—	—	—	—	—	—	—
bit 15							bit 8

U-0	R/W-1	R/W-0	R/W-0	U-0	U-0	U-0	U-0
—	U1EIP2	U1EIP1	U1EIP0	—	—	—	—
bit 7							bit 0

Legend:			
R = Readable bit	W = Writable bit	U = Unimplemented bit, read as '0'	
-n = Value at POR	'1' = Bit is set	'0' = Bit is cleared	x = Bit is unknown

bit 15-7 **Unimplemented:** Read as '0'

bit 6-4 **U1EIP<2:0>:** UART1 Error Interrupt Priority bits
 111 = Interrupt is Priority 7 (highest priority interrupt)
 •
 •
 •
 001 = Interrupt is Priority 1
 000 = Interrupt source is disabled

bit 3-0 **Unimplemented:** Read as '0'

dsPIC33FJ06GS101/X02 and dsPIC33FJ16GSX02/X04

REGISTER 7-28: IPC23: INTERRUPT PRIORITY CONTROL REGISTER 23

U-0	R/W-1	R/W-0	R/W-0	U-0	R/W-1	R/W-0	R/W-0
—	PWM2IP2	PWM2IP1	PWM2IP0	—	PWM1IP2	PWM1IP1	PWM1IP0
bit 15							bit 8

U-0	U-0	U-0	U-0	U-0	U-0	U-0	U-0
—	—	—	—	—	—	—	—
bit 7							bit 0

Legend:

R = Readable bit

W = Writable bit

U = Unimplemented bit, read as '0'

-n = Value at POR

'1' = Bit is set

'0' = Bit is cleared

x = Bit is unknown

bit 15 **Unimplemented:** Read as '0'

bit 14-12 **PWM2IP<2:0>:** PWM2 Interrupt Priority bits

111 = Interrupt is Priority 7 (highest priority)

-
-
-

001 = Interrupt is Priority 1

000 = Interrupt source is disabled

bit 11 **Unimplemented:** Read as '0'

bit 10-8 **PWM1IP<2:0>:** PWM1 Interrupt Priority bits

111 = Interrupt is Priority 7 (highest priority)

-
-
-

001 = Interrupt is Priority 1

000 = Interrupt source is disabled

bit 7-0 **Unimplemented:** Read as '0'

dsPIC33FJ06GS101/X02 and dsPIC33FJ16GSX02/X04

REGISTER 7-29: IPC24: INTERRUPT PRIORITY CONTROL REGISTER 24

U-0	U-0	U-0	U-0	U-0	U-0	U-0	U-0
—	—	—	—	—	—	—	—
bit 15							bit 8

U-0	R/W-1	R/W-0	R/W-0	U-0	R/W-1	R/W-0	R/W-0
—	PWM4IP2	PWM4IP1	PWM4IP0	—	PWM3IP2	PWM3IP1	PWM3IP0
bit 7							bit 0

Legend:

R = Readable bit W = Writable bit U = Unimplemented bit, read as '0'
 -n = Value at POR '1' = Bit is set '0' = Bit is cleared x = Bit is unknown

- bit 15-7 **Unimplemented:** Read as '0'
- bit 6-4 **PWM4IP<2:0>:** PWM4 Interrupt Priority bits
 - 111 = Interrupt is Priority 7 (highest priority)
 -
 -
 -
 - 001 = Interrupt is Priority 1
 - 000 = Interrupt source is disabled
- bit 3 **Unimplemented:** Read as '0'
- bit 2-0 **PWM3IP<2:0>:** PWM3 Interrupt Priority bits
 - 111 = Interrupt is Priority 7 (highest priority)
 -
 -
 -
 - 001 = Interrupt is Priority 1
 - 000 = Interrupt source is disabled

dsPIC33FJ06GS101/X02 and dsPIC33FJ16GSX02/X04

REGISTER 7-30: IPC25: INTERRUPT PRIORITY CONTROL REGISTER 25

U-0	R/W-1	R/W-0	R/W-0	U-0	U-0	U-0	U-0
—	AC2IP2	AC2IP1	AC2IP0	—	—	—	—
bit 15							bit 8

U-0	U-0	U-0	U-0	U-0	U-0	U-0	U-0
—	—	—	—	—	—	—	—
bit 7							bit 0

Legend:

R = Readable bit	W = Writable bit	U = Unimplemented bit, read as '0'
-n = Value at POR	'1' = Bit is set	'0' = Bit is cleared x = Bit is unknown

- bit 15 **Unimplemented:** Read as '0'
- bit 14-12 **AC2IP<2:0>:** Analog Comparator 2 Interrupt Priority bits
 - 111 = Interrupt is Priority 7 (highest priority)
 -
 -
 -
 - 001 = Interrupt is Priority 1
 - 000 = Interrupt source is disabled
- bit 11-01 **Unimplemented:** Read as '0'

dsPIC33FJ06GS101/X02 and dsPIC33FJ16GSX02/X04

REGISTER 7-31: IPC26: INTERRUPT PRIORITY CONTROL REGISTER 26

U-0	U-0	U-0	U-0	U-0	U-0	U-0	U-0
—	—	—	—	—	—	—	—
bit 15							bit 8

U-0	R/W-1	R/W-0	R/W-0	U-0	R/W-1	R/W-0	R/W-0
—	AC4IP2	AC4IP1	AC4IP0	—	AC3IP2	AC3IP1	AC3IP0
bit 7							bit 0

Legend:

R = Readable bit W = Writable bit U = Unimplemented bit, read as '0'
-n = Value at POR '1' = Bit is set '0' = Bit is cleared x = Bit is unknown

bit 15-7 **Unimplemented:** Read as '0'

bit 6-4 **AC4IP<2:0>:** Analog Comparator 4 Interrupt Priority bits
111 = Interrupt is Priority 7 (highest priority)
•
•
•
001 = Interrupt is Priority 1
000 = Interrupt source is disabled

bit 3 **Unimplemented:** Read as '0'

bit 2-0 **AC3IP<2:0>:** Analog Comparator 3 Interrupt Priority bits
111 = Interrupt is Priority 7 (highest priority)
•
•
•
001 = Interrupt is Priority 1
000 = Interrupt source is disabled

dsPIC33FJ06GS101/X02 and dsPIC33FJ16GSX02/X04

REGISTER 7-32: IPC27: INTERRUPT PRIORITY CONTROL REGISTER 27

U-0	R/W-1	R/W-0	R/W-0	U-0	R/W-1	R/W-0	R/W-0
—	ADCP1IP2	ADCP1IP1	ADCP1IP0	—	ADCP0IP2	ADCP0IP1	ADCP0IP0
bit 15							bit 8

U-0	U-0	U-0	U-0	U-0	U-0	U-0	U-0
—	—	—	—	—	—	—	—
bit 7							bit 0

Legend:

R = Readable bit W = Writable bit U = Unimplemented bit, read as '0'
 -n = Value at POR '1' = Bit is set '0' = Bit is cleared x = Bit is unknown

- bit 15 **Unimplemented:** Read as '0'
- bit 14-12 **ADCP1IP<2:0>:** ADC Pair 1 Conversion Done Interrupt Priority bits
 - 111 = Interrupt is Priority 7 (highest priority interrupt)
 -
 -
 -
 - 001 = Interrupt is Priority 1
 - 000 = Interrupt source is disabled
- bit 11 **Unimplemented:** Read as '0'
- bit 10-8 **ADCP0IP<2:0>:** ADC Pair 0 Conversion Done Interrupt Priority bits
 - 111 = Interrupt is Priority 7 (highest priority interrupt)
 -
 -
 -
 - 001 = Interrupt is Priority 1
 - 000 = Interrupt source is disabled
- bit 7-0 **Unimplemented:** Read as '0'

dsPIC33FJ06GS101/X02 and dsPIC33FJ16GSX02/X04

REGISTER 7-33: IPC28: INTERRUPT PRIORITY CONTROL REGISTER 28

U-0	R/W-1	R/W-0	R/W-0	U-0	R/W-1	R/W-0	R/W-0
—	ADCP5IP2	ADCP5IP1	ADCP5IP0	—	ADCP4IP2	ADCP4IP1	ADCP4IP0
bit 15							bit 8

U-0	R/W-1	R/W-0	R/W-0	U-0	R/W-1	R/W-0	R/W-0
—	ADCP3IP2	ADCP3IP1	ADCP3IP0	—	ADCP2IP2	ADCP2IP1	ADCP2IP0
bit 7							bit 0

Legend:

R = Readable bit W = Writable bit U = Unimplemented bit, read as '0'
 -n = Value at POR '1' = Bit is set '0' = Bit is cleared x = Bit is unknown

- bit 15 **Unimplemented:** Read as '0'
- bit 14-12 **ADCP5IP<2:0>:** ADC Pair 5 Conversion Done Interrupt Priority bits
 111 = Interrupt is Priority 7 (highest priority interrupt)
 •
 •
 •
 001 = Interrupt is Priority 1
 000 = Interrupt source is disabled
- bit 11 **Unimplemented:** Read as '0'
- bit 10-8 **ADCP4IP<2:0>:** ADC Pair 4 Conversion Done Interrupt Priority bits
 111 = Interrupt is Priority 7 (highest priority interrupt)
 •
 •
 •
 001 = Interrupt is Priority 1
 000 = Interrupt source is disabled
- bit 7 **Unimplemented:** Read as '0'
- bit 6-4 **ADCP3IP<2:0>:** ADC Pair 3 Conversion Done Interrupt Priority bits
 111 = Interrupt is Priority 7 (highest priority interrupt)
 •
 •
 •
 001 = Interrupt is Priority 1
 000 = Interrupt source is disabled
- bit 3 **Unimplemented:** Read as '0'
- bit 2-0 **ADCP2IP<2:0>:** ADC Pair 2 Conversion Done Interrupt Priority bits
 111 = Interrupt is Priority 7 (highest priority interrupt)
 •
 •
 •
 001 = Interrupt is Priority 1
 000 = Interrupt source is disabled

dsPIC33FJ06GS101/X02 and dsPIC33FJ16GSX02/X04

REGISTER 7-34: IPC29: INTERRUPT PRIORITY CONTROL REGISTER 29

U-0	U-0	U-0	U-0	U-0	U-0	U-0	U-0
—	—	—	—	—	—	—	—
bit 15							bit 8

U-0	U-0	U-0	U-0	U-0	R/W-1	R/W-0	R/W-0
—	—	—	—	—	ADCP6IP2	ADCP6IP1	ADCP6IP0
bit 7							bit 0

Legend:

R = Readable bit W = Writable bit U = Unimplemented bit, read as '0'
 -n = Value at POR '1' = Bit is set '0' = Bit is cleared x = Bit is unknown

bit 15-3 **Unimplemented:** Read as '0'
 bit 2-0 **ADCP6IP<2:0>:** ADC Pair 6 Conversion Done Interrupt 1 Priority bits

- 111 = Interrupt is Priority 7 (highest priority interrupt)
-
-
-
- 001 = Interrupt is Priority 1
- 000 = Interrupt source is disabled

dsPIC33FJ06GS101/X02 and dsPIC33FJ16GSX02/X04

REGISTER 7-35: INTTREG: INTERRUPT CONTROL AND STATUS REGISTER

U-0	U-0	U-0	U-0	R-0	R-0	R-0	R-0
—	—	—	—	ILR3	ILR2	ILR1	ILR0
bit 15							bit 8

U-0	R-0	R-0	R-0	R-0	R-0	R-0	R-0
—	VECNUM6	VECNUM5	VECNUM4	VECNUM3	VECNUM2	VECNUM1	VECNUM0
bit 7							bit 0

Legend:

R = Readable bit

W = Writable bit

U = Unimplemented bit, read as '0'

-n = Value at POR

'1' = Bit is set

'0' = Bit is cleared

x = Bit is unknown

bit 15-12 **Unimplemented:** Read as '0'

bit 11-8 **ILR<3:0>:** New CPU Interrupt Priority Level bits

1111 = CPU Interrupt Priority Level is 15

-
-
-

0001 = CPU Interrupt Priority Level is 1

0000 = CPU Interrupt Priority Level is 0

bit 7 **Unimplemented:** Read as '0'

bit 6-0 **VECNUM<6:0>:** Vector Number of Pending Interrupt bits

0111111 = Interrupt vector pending is Number 135

-
-
-

0000001 = Interrupt vector pending is Number 9

0000000 = Interrupt vector pending is Number 8

dsPIC33FJ06GS101/X02 and dsPIC33FJ16GSX02/X04

7.4 Interrupt Setup Procedures

7.4.1 INITIALIZATION

Complete the following steps to configure an interrupt source at initialization:

1. Set the NSTDIS bit (INTCON1<15>) if nested interrupts are not desired.
2. Select the user-assigned priority level for the interrupt source by writing the control bits in the appropriate IPCx register. The priority level will depend on the specific application and type of interrupt source. If multiple priority levels are not desired, the IPCx register control bits for all enabled interrupt sources can be programmed to the same non-zero value.

Note: At a device Reset, the IPCx registers are initialized such that all user interrupt sources are assigned to Priority Level 4.

3. Clear the interrupt flag status bit associated with the peripheral in the associated IFSx register.
4. Enable the interrupt source by setting the interrupt enable control bit associated with the source in the appropriate IECx register.

7.4.2 INTERRUPT SERVICE ROUTINE

The method used to declare an ISR and initialize the IVT with the correct vector address depends on the programming language (C or assembler) and the language development toolsuite used to develop the application.

In general, the user application must clear the interrupt flag in the appropriate IFSx register for the source of interrupt that the ISR handles. Otherwise, program will re-enter the ISR immediately after exiting the routine. If the ISR is coded in assembly language, it must be terminated using a `RETFIE` instruction to unstack the saved PC value, SRL value and old CPU priority level.

7.4.3 TRAP SERVICE ROUTINE

A Trap Service Routine (TSR) is coded like an ISR, except that the appropriate trap status flag in the INTCON1 register must be cleared to avoid re-entry into the TSR.

7.4.4 INTERRUPT DISABLE

The following steps outline the procedure to disable all user interrupts:

1. Push the current SR value onto the software stack using the `PUSH` instruction.
2. Force the CPU to Priority Level 7 by inclusive ORing the value `0xE0` with SRL.

To enable user interrupts, the `POP` instruction can be used to restore the previous SR value.

Note: Only user interrupts with a priority level of 7 or lower can be disabled. Trap sources (level 8-level 15) cannot be disabled.

The `DISI` instruction provides a convenient way to disable interrupts of Priority Levels 1-6 for a fixed period of time. Level 7 interrupt sources are not disabled by the `DISI` instruction.

dsPIC33FJ06GS101/X02 and dsPIC33FJ16GSX02/X04

8.0 OSCILLATOR CONFIGURATION

Note 1: This data sheet summarizes the features of the dsPIC33FJ06GS101/X02 and dsPIC33FJ16GSX02/X04 families of devices. It is not intended to be a comprehensive reference source. To complement the information in this data sheet, refer to “**Oscillator (Part IV)**” (DS70307) in the “dsPIC33F/PIC24H Family Reference Manual”, which is available from the Microchip web site (www.microchip.com).

2: Some registers and associated bits described in this section may not be available on all devices. Refer to **Section 4.0 “Memory Organization”** in this data sheet for device-specific register and bit information.

The oscillator system provides:

- External and internal oscillator options as clock sources
- An on-chip Phase-Locked Loop (PLL) to scale the internal operating frequency to the required system clock frequency
- An internal FRC oscillator that can also be used with the PLL, thereby allowing full-speed operation without any external clock generation hardware
- Clock switching between various clock sources
- Programmable clock postscaler for system power savings
- A Fail-Safe Clock Monitor (FSCM) that detects clock failure and takes fail-safe measures
- A Clock Control register (OSCCON)
- Nonvolatile Configuration bits for main oscillator selection
- Auxiliary PLL for ADC and PWM

A simplified diagram of the oscillator system is shown in **Figure 8-1**.

FIGURE 8-1: OSCILLATOR SYSTEM DIAGRAM



dsPIC33FJ06GS101/X02 and dsPIC33FJ16GSX02/X04

8.1 CPU Clocking System

The dsPIC33FJ06GS101/X02 and dsPIC33FJ16GSX02/X04 devices provide six system clock options:

- Fast RC (FRC) Oscillator
- FRC Oscillator with PLL
- Primary (XT, HS or EC) Oscillator
- Primary Oscillator with PLL
- Low-Power RC (LPRC) Oscillator
- FRC Oscillator with Postscaler

8.1.1 SYSTEM CLOCK SOURCES

The Fast RC (FRC) internal oscillator runs at a nominal frequency of 7.37 MHz. User software can tune the FRC frequency. User software can optionally specify a factor (ranging from 1:2 to 1:256) by which the FRC clock frequency is divided. This factor is selected using the FRCDIV<2:0> (CLKDIV<10:8>) bits.

The primary oscillator can use one of the following as its clock source:

- XT (Crystal): Crystals and ceramic resonators in the range of 3 MHz to 10 MHz. The crystal is connected to the OSC1 and OSC2 pins.
- HS (High-Speed Crystal): Crystals in the range of 10 MHz to 40 MHz. The crystal is connected to the OSC1 and OSC2 pins.
- EC (External Clock): The external clock signal is directly applied to the OSC1 pin.

The LPRC internal oscillator runs at a nominal frequency of 32.768 kHz. It is also used as a reference clock by the Watchdog Timer (WDT) and Fail-Safe Clock Monitor (FSCM).

The clock signals generated by the FRC and primary oscillators can be optionally applied to an on-chip Phase-Locked Loop (PLL) to provide a wide range of

output frequencies for device operation. PLL configuration is described in [Section 8.1.3 “PLL Configuration”](#).

The FRC frequency depends on the FRC accuracy (see [Table 24-20](#)) and the value of the FRC Oscillator Tuning register (see [Register 8-4](#)).

8.1.2 SYSTEM CLOCK SELECTION

The oscillator source used at a device Power-on Reset event is selected using Configuration bit settings. The Oscillator Configuration bit settings are located in the Configuration registers in the program memory. (Refer to [Section 21.1 “Configuration Bits”](#) for further details.) The Initial Oscillator Selection Configuration bits, FNOSC<2:0> (FOSCSEL<2:0>), and the Primary Oscillator Mode Select Configuration bits, POSCMD<1:0> (FOSC<1:0>), select the oscillator source that is used at a Power-on Reset. The FRC primary oscillator is the default (unprogrammed) selection.

The Configuration bits allow users to choose among 12 different clock modes, shown in [Table 8-1](#).

The output of the oscillator (or the output of the PLL if a PLL mode has been selected), FOSC, is divided by 2 to generate the device instruction clock (FCY) and the peripheral clock time base (FP). FCY defines the operating speed of the device and speeds up to 40 MHz are supported by the dsPIC33FJ06GS101/X02 and dsPIC33FJ16GSX02/X04 architecture.

Instruction execution speed or device operating frequency, FCY, is given by [Equation 8-1](#).

EQUATION 8-1: DEVICE OPERATING FREQUENCY

$$FCY = FOSC/2$$

TABLE 8-1: CONFIGURATION BIT VALUES FOR CLOCK SELECTION

Oscillator Mode	Oscillator Source	POSCMD<1:0>	FNOSC<2:0>	See Notes
Fast RC Oscillator with Divide-by-N (FRCDIVN)	Internal	xx	111	1 , 2
Fast RC Oscillator with Divide-by-16 (FRCDIV16)	Internal	xx	110	1
Low-Power RC Oscillator (LPRC)	Internal	xx	101	1
Reserved	Reserved	xx	100	—
Primary Oscillator (HS) with PLL (HSPLL)	Primary	10	011	—
Primary Oscillator (XT) with PLL (XTPLL)	Primary	01	011	—
Primary Oscillator (EC) with PLL (ECPLL)	Primary	00	011	1
Primary Oscillator (HS)	Primary	10	010	—
Primary Oscillator (XT)	Primary	01	010	—
Primary Oscillator (EC)	Primary	00	010	1
Fast RC Oscillator with PLL (FRCPLL)	Internal	xx	001	1
Fast RC Oscillator (FRC)	Internal	xx	000	1

Note 1: OSC2 pin function is determined by the OSCIOFNC Configuration bit.

2: This is the default oscillator mode for an unprogrammed (erased) device.

dsPIC33FJ06GS101/X02 and dsPIC33FJ16GSX02/X04

8.1.3 PLL CONFIGURATION

The primary oscillator and internal FRC oscillator can optionally use an on-chip PLL to obtain higher speeds of operation. The PLL provides significant flexibility in selecting the device operating speed. A block diagram of the PLL is shown in [Figure 8-2](#).

The output of the primary oscillator or FRC, denoted as 'FIN', is divided down by a prescale factor (N1) of 2, 3, ... or 33 before being provided to the PLL's Voltage Controlled Oscillator (VCO). The input to the VCO must be selected in the range of 0.8 MHz to 8 MHz. The prescale factor 'N1' is selected using the PLLPRE<4:0> bits (CLKDIV<4:0>).

The PLL Feedback Divisor, selected using the PLLDIV<8:0> bits (PLLFBD<8:0>), provides a factor, 'M', by which the input to the VCO is multiplied. This factor must be selected such that the resulting VCO output frequency is in the range of 100 MHz to 200 MHz.

The VCO output is further divided by a postscale factor, 'N2'. This factor is selected using the PLLPOST<1:0> bits (CLKDIV<7:6>). 'N2' can be either 2, 4, or 8, and must be selected such that the PLL output frequency (Fosc) is in the range of 12.5 MHz to 80 MHz, which generates device operating speeds of 6.25-40 MIPS.

For a primary oscillator or FRC oscillator, output 'FIN', the PLL output 'Fosc' is given by [Equation 8-2](#).

EQUATION 8-2: Fosc CALCULATION

$$F_{OSC} = F_{IN} * \left(\frac{M}{N1 * N2} \right)$$

For example, suppose a 10 MHz crystal is being used with the selected oscillator mode of XT with PLL (see [Equation 8-3](#)).

- If PLLPRE<4:0> = 0, then N1 = 2. This yields a VCO input of 10/2 = 5 MHz, which is within the acceptable range of 0.8-8 MHz.
- If PLLDIV<8:0> = 0x1E, then M = 32. This yields a VCO output of 5 x 32 = 160 MHz, which is within the 100-200 MHz range needed.
- If PLLPOST<1:0> = 0, then N2 = 2. This provides a Fosc of 160/2 = 80 MHz. The resultant device operating speed is 80/2 = 40 MIPS.

EQUATION 8-3: XT WITH PLL MODE EXAMPLE

$$F_{CY} = \frac{F_{OSC}}{2} = \frac{1}{2} \left(\frac{10000000 * 32}{2 * 2} \right) = 40 \text{ MIPS}$$

FIGURE 8-2: dsPIC33FJ06GS101/X02 and dsPIC33FJ16GSX02/X04 PLL BLOCK DIAGRAM



dsPIC33FJ06GS101/X02 and dsPIC33FJ16GSX02/X04

8.2 Auxiliary Clock Generation

The auxiliary clock generation is used for peripherals that need to operate at a frequency unrelated to the system clock such as a PWM or ADC.

The primary oscillator and internal FRC oscillator sources can be used with an auxiliary PLL to obtain the auxiliary clock. The auxiliary PLL has a fixed 16x multiplication factor.

The auxiliary clock has the following configuration restrictions:

- For proper PWM operation, auxiliary clock generation must be configured for 120 MHz (see Parameter [OS56](#) in [Table 24-18](#) in [Section 24.0 “Electrical Characteristics”](#)). If a slower frequency is desired, the PWM Input Clock Prescaler (Divider) Select bits (PCLKDIV<2:0>) should be used.
- To achieve 1.04 ns PWM resolution, the auxiliary clock must use the 16x auxiliary PLL (APLL). All other clock sources will have a minimum PWM resolution of 8 ns.
- If the primary PLL is used as a source for the auxiliary clock, the primary PLL should be configured up to a maximum operation of 30 MIPS or less

8.3 Reference Clock Generation

The reference clock output logic provides the user with the ability to output a clock signal based on the system clock or the crystal oscillator on a device pin. The user application can specify a wide range of clock scaling prior to outputting the reference clock.

dsPIC33FJ06GS101/X02 and dsPIC33FJ16GSX02/X04

8.4 Oscillator Control Registers

REGISTER 8-1: OSCCON: OSCILLATOR CONTROL REGISTER^(1,2)

U-0	R-0	R-0	R-0	U-0	R/W-y	R/W-y	R/W-y
—	COSC2	COSC1	COSC0	—	NOSC2 ⁽³⁾	NOSC1 ⁽³⁾	NOSC0 ⁽³⁾
bit 15				bit 8			

R/W-0	R/W-0	R-0	U-0	R/C-0	U-0	U-0	R/W-0
CLKLOCK	IOLOCK	LOCK	—	CF	—	—	OSWEN
bit 7				bit 0			

Legend:	y = Value set from Configuration bits on POR
R = Readable bit	W = Writable bit
-n = Value at POR	'1' = Bit is set
	U = Unimplemented bit, read as '0'
	'0' = Bit is cleared
	x = Bit is unknown

- bit 15 **Unimplemented:** Read as '0'
- bit 14-12 **COSC<2:0>:** Current Oscillator Selection bits (read-only)
 - 111 = Fast RC oscillator (FRC) with divide-by-n
 - 110 = Fast RC oscillator (FRC) with divide-by-16
 - 101 = Low-Power RC oscillator (LPRC)
 - 100 = Reserved
 - 011 = Primary oscillator (XT, HS, EC) with PLL
 - 010 = Primary oscillator (XT, HS, EC)
 - 001 = Fast RC oscillator (FRC) with PLL
 - 000 = Fast RC oscillator (FRC)
- bit 11 **Unimplemented:** Read as '0'
- bit 10-8 **NOSC<2:0>:** New Oscillator Selection bits⁽³⁾
 - 111 = Fast RC oscillator (FRC) with divide-by-n
 - 110 = Fast RC oscillator (FRC) with divide-by-16
 - 101 = Low-Power RC oscillator (LPRC)
 - 100 = Reserved
 - 011 = Primary oscillator (XT, HS, EC) with PLL
 - 010 = Primary oscillator (XT, HS, EC)
 - 001 = Fast RC oscillator (FRC) with PLL
 - 000 = Fast RC oscillator (FRC)
- bit 7 **CLKLOCK:** Clock Lock Enable bit
 - If Clock Switching is Enabled and FSCM is Disabled, (FOSC<FCKSM> = 0b01):
 - 1 = Clock switching is disabled, system clock source is locked
 - 0 = Clock switching is enabled, system clock source can be modified by clock switching
- bit 6 **IOLOCK:** Peripheral Pin Select Lock bit
 - 1 = Peripheral Pin Select is locked, write to Peripheral Pin Select registers not allowed
 - 0 = Peripheral Pin Select is not locked, write to Peripheral Pin Select registers allowed
- bit 5 **LOCK:** PLL Lock Status bit (read-only)
 - 1 = Indicates that PLL is in lock, or PLL start-up timer is satisfied
 - 0 = Indicates that PLL is out of lock, start-up timer is in progress or PLL is disabled
- bit 4 **Unimplemented:** Read as '0'

- Note 1:** Writes to this register require an unlock sequence. Refer to “**Oscillator (Part IV)**” (DS70307) in the “*dsPIC33F/PIC24H Family Reference Manual*” (available from the Microchip web site) for details.
- 2:** This register is reset only on a Power-on Reset (POR).
- 3:** Direct clock switches between any primary oscillator mode with PLL and FRCPLL mode are not permitted. This applies to clock switches in either direction. In these instances, the application must switch to FRC mode as a transition clock source between the two PLL modes.

dsPIC33FJ06GS101/X02 and dsPIC33FJ16GSX02/X04

REGISTER 8-1: OSCCON: OSCILLATOR CONTROL REGISTER^(1,2) (CONTINUED)

- bit 3 **CF:** Clock Fail Detect bit (read/clear by application)
 1 = FSCM has detected clock failure
 0 = FSCM has not detected clock failure
- bit 2-1 **Unimplemented:** Read as '0'
- bit 0 **OSWEN:** Oscillator Switch Enable bit
 1 = Request oscillator switch to selection specified by NOSC<2:0> bits
 0 = Oscillator switch is complete

- Note 1:** Writes to this register require an unlock sequence. Refer to “**Oscillator (Part IV)**” (DS70307) in the “*dsPIC33F/PIC24H Family Reference Manual*” (available from the Microchip web site) for details.
- 2:** This register is reset only on a Power-on Reset (POR).
- 3:** Direct clock switches between any primary oscillator mode with PLL and FRCPLL mode are not permitted. This applies to clock switches in either direction. In these instances, the application must switch to FRC mode as a transition clock source between the two PLL modes.

dsPIC33FJ06GS101/X02 and dsPIC33FJ16GSX02/X04

REGISTER 8-2: CLKDIV: CLOCK DIVISOR REGISTER⁽¹⁾

R/W-0	R/W-0	R/W-1	R/W-1	R/W-0	R/W-0	R/W-0	R/W-0
ROI	DOZE2	DOZE1	DOZE0	DOZEN ⁽²⁾	FRCDIV2	FRCDIV1	FRCDIV0
bit 15							bit 8

R/W-0	R/W-1	U-0	R/W-0	R/W-0	R/W-0	R/W-0	R/W-0
PLLPOST1	PLLPOST0	—	PLLPRE4	PLLPRE3	PLLPRE2	PLLPRE1	PLLPRE0
bit 7							bit 0

Legend:

R = Readable bit	W = Writable bit	U = Unimplemented bit, read as '0'
-n = Value at POR	'1' = Bit is set	'0' = Bit is cleared
		x = Bit is unknown

- bit 15 **ROI:** Recover on Interrupt bit
 1 = Interrupts will clear the DOZEN bit and the processor clock/peripheral clock ratio is set to 1:1
 0 = Interrupts have no effect on the DOZEN bit
- bit 14-12 **DOZE<2:0>:** Processor Clock Reduction Select bits
 111 = Fcy/128
 110 = Fcy/64
 101 = Fcy/32
 100 = Fcy/16
 011 = Fcy/8 (default)
 010 = Fcy/4
 001 = Fcy/2
 000 = Fcy/1
- bit 11 **DOZEN:** Doze Mode Enable bit⁽²⁾
 1 = DOZE<2:0> field specifies the ratio between the peripheral clocks and the processor clocks
 0 = Processor clock/peripheral clock ratio forced to 1:1
- bit 10-8 **FRCDIV<2:0>:** Internal Fast RC Oscillator Postscaler bits
 111 = FRC divide-by-256
 110 = FRC divide-by-64
 101 = FRC divide-by-32
 100 = FRC divide-by-16
 011 = FRC divide-by-8
 010 = FRC divide-by-4
 001 = FRC divide-by-2
 000 = FRC divide-by-1 (default)
- bit 7-6 **PLLPOST<1:0>:** PLL VCO Output Divider Select bits (also denoted as 'N2', PLL postscaler)
 11 = Output/8
 10 = Reserved
 01 = Output/4 (default)
 00 = Output/2
- bit 5 **Unimplemented:** Read as '0'
- bit 4-0 **PLLPRE<4:0>:** PLL Phase Detector Input Divider bits (also denoted as 'N1', PLL prescaler)
 11111 = Input/33
 •
 •
 •
 00001 = Input/3
 00000 = Input/2 (default)

- Note 1:** This register is reset only on a Power-on Reset (POR).
Note 2: This bit is cleared when the ROI bit is set and an interrupt occurs.

dsPIC33FJ06GS101/X02 and dsPIC33FJ16GSX02/X04

REGISTER 8-3: PLLFBD: PLL FEEDBACK DIVISOR REGISTER⁽¹⁾

U-0	U-0	U-0	U-0	U-0	U-0	U-0	R/W-0
—	—	—	—	—	—	—	PLLDIV<8>
bit 15							bit 8

R/W-0	R/W-0	R/W-1	R/W-1	R/W-0	R/W-0	R/W-0	R/W-0
PLLDIV<7:0>							
bit 7							bit 0

Legend:

R = Readable bit W = Writable bit U = Unimplemented bit, read as '0'
 -n = Value at POR '1' = Bit is set '0' = Bit is cleared x = Bit is unknown

bit 15-9 **Unimplemented:** Read as '0'
 bit 8-0 **PLLDIV<8:0>:** PLL Feedback Divisor bits (also denoted as 'M', PLL multiplier)
 111111111 = 513
 •
 •
 •
 000110000 = 50 (default)
 •
 •
 •
 000000010 = 4
 000000001 = 3
 000000000 = 2

Note 1: This register is reset only on a Power-on Reset (POR).

dsPIC33FJ06GS101/X02 and dsPIC33FJ16GSX02/X04

REGISTER 8-4: OSCTUN: FRC OSCILLATOR TUNING REGISTER⁽¹⁾

U-0	U-0	U-0	U-0	U-0	U-0	U-0	U-0
—	—	—	—	—	—	—	—
bit 15							bit 8

U-0	U-0	R/W-0	R/W-0	R/W-0	R/W-0	R/W-0	R/W-0
—	—	TUN<5:0> ⁽²⁾					
bit 7							bit 0

Legend:

R = Readable bit

W = Writable bit

U = Unimplemented bit, read as '0'

-n = Value at POR

'1' = Bit is set

'0' = Bit is cleared

x = Bit is unknown

bit 15-6 **Unimplemented:** Read as '0'

bit 5-0 **TUN<5:0>:** FRC Oscillator Tuning bits⁽²⁾

011111 = Center frequency + 11.6% (8.2268 MHz)

011110 = Center frequency + 11.2% (8.1992 MHz)

•

•

•

000001 = Center frequency + 0.375% (7.3976 MHz)

000000 = Center frequency (7.37 MHz nominal)

111111 = Center frequency – 0.375% (7.2594 MHz)

•

•

•

100001 = Center frequency – 11.6% (6.5132 MHz)

000000 = Center frequency – 12% (6.4856 MHz)

Note 1: This register is reset only on a Power-on Reset (POR).

Note 2: OSCTUN functionality has been provided to help customers compensate for temperature effects on the FRC frequency over a wide range of temperatures. The tuning step-size is an approximation and is neither characterized nor tested.

dsPIC33FJ06GS101/X02 and dsPIC33FJ16GSX02/X04

REGISTER 8-5: ACLKCON: AUXILIARY CLOCK DIVISOR CONTROL REGISTER⁽¹⁾

R/W-0	R-0	R/W-1	U-0	U-0	R/W-1	R/W-1	R/W-1
ENAPLL	APLLCK	SELACLK	—	—	APSTSCLR2	APSTSCLR1	APSTSCLR0
bit 15						bit 0	

R/W-0	R/W-0	U-0	U-0	U-0	U-0	U-0	U-0
ASRCSEL	FRCSEL	—	—	—	—	—	—
bit 7							

Legend:

R = Readable bit W = Writable bit U = Unimplemented bit, read as '0'
 -n = Value at POR '1' = Bit is set '0' = Bit is cleared x = Bit is unknown

- bit 15 **ENAPLL:** Auxiliary PLL Enable bit
 1 = APLL is enabled
 0 = APLL is disabled
- bit 14 **APLLCK:** APLL Locked Status bit (read-only)
 1 = Indicates that auxiliary PLL is in lock
 0 = Indicates that auxiliary PLL is not in lock
- bit 13 **SELACLK:** Select Auxiliary Clock Source for Auxiliary Clock Divider bit
 1 = Auxiliary oscillators provides the source clock for auxiliary clock divider
 0 = Primary PLL (Fvco) provides the source clock for auxiliary clock divider
- bit 12-11 **Unimplemented:** Read as '0'
- bit 10-8 **APSTSCLR<2:0>:** Auxiliary Clock Output Divider bits
 111 = Divided by 1
 110 = Divided by 2
 101 = Divided by 4
 100 = Divided by 8
 011 = Divided by 16
 010 = Divided by 32
 001 = Divided by 64
 000 = Divided by 256
- bit 7 **ASRCSEL:** Select Reference Clock Source for Auxiliary Clock bit
 1 = Primary oscillator is the clock source
 0 = No clock input is selected
- bit 6 **FRCSEL:** Select Reference Clock Source for Auxiliary PLL bit
 1 = Select FRC clock for auxiliary PLL
 0 = Input clock source is determined by ASRCSEL bit setting
- bit 5-0 **Unimplemented:** Read as '0'

Note 1: This register is reset only on a Power-on Reset (POR).

dsPIC33FJ06GS101/X02 and dsPIC33FJ16GSX02/X04

REGISTER 8-6: REFOCON: REFERENCE OSCILLATOR CONTROL REGISTER

R/W-0	U-0	R/W-0	R/W-0	R/W-0	R/W-0	R/W-0	R/W-0
ROON	—	ROSSLP	ROSEL	RODIV3 ⁽¹⁾	RODIV2 ⁽¹⁾	RODIV1 ⁽¹⁾	RODIV0 ⁽¹⁾
bit 15							bit 8

U-0	U-0	U-0	U-0	U-0	U-0	U-0	U-0
—	—	—	—	—	—	—	—
bit 7							bit 0

Legend:

R = Readable bit W = Writable bit U = Unimplemented bit, read as '0'
 -n = Value at POR '1' = Bit is set '0' = Bit is cleared x = Bit is unknown

- bit 15 **ROON:** Reference Oscillator Output Enable bit
 1 = Reference oscillator output is enabled on the REFCLK0 pin⁽²⁾
 0 = Reference oscillator output is disabled
- bit 14 **Unimplemented:** Read as '0'
- bit 13 **ROSSLP:** Reference Oscillator Run in Sleep bit
 1 = Reference oscillator output continues to run in Sleep
 0 = Reference oscillator output is disabled in Sleep
- bit 12 **ROSEL:** Reference Oscillator Source Select bit
 1 = Oscillator crystal is used as the reference clock
 0 = System clock is used as the reference clock
- bit 11-8 **RODIV<3:0>:** Reference Oscillator Divider bits⁽¹⁾
 1111 = Reference clock divided by 32,768
 1110 = Reference clock divided by 16,384
 1101 = Reference clock divided by 8,192
 1100 = Reference clock divided by 4,096
 1011 = Reference clock divided by 2,048
 1010 = Reference clock divided by 1,024
 1001 = Reference clock divided by 512
 1000 = Reference clock divided by 256
 0111 = Reference clock divided by 128
 0110 = Reference clock divided by 64
 0101 = Reference clock divided by 32
 0100 = Reference clock divided by 16
 0011 = Reference clock divided by 8
 0010 = Reference clock divided by 4
 0001 = Reference clock divided by 2
 0000 = Reference clock
- bit 7-0 **Unimplemented:** Read as '0'

- Note 1:** The reference oscillator output must be disabled (ROON = 0) before writing to these bits.
Note 2: This pin is remappable. Refer to [Section 10.6 “Peripheral Pin Select”](#) for more information.

dsPIC33FJ06GS101/X02 and dsPIC33FJ16GSX02/X04

8.5 Clock Switching Operation

Users can switch applications among any of the four clock sources (primary, LP, FRC and LPRC) under software control at any time. To limit the possible side effects of this flexibility, dsPIC33FJ06GS101/X02 and dsPIC33FJ16GSX02/X04 devices have a safeguard lock built into the switch process.

Note: Primary oscillator mode has three different submodes (XT, HS and EC), which are determined by the POSCMD<1:0> Configuration bits. While an application can switch to and from primary oscillator mode in software, it cannot switch among the different primary submodes without reprogramming the device.

8.5.1 ENABLING CLOCK SWITCHING

To enable clock switching, the FCKSM1 Configuration bit in the Configuration register must be programmed to '0'. (Refer to [Section 21.1 “Configuration Bits”](#) for further details.) If the FCKSM1 Configuration bit is unprogrammed ('1'), the clock switching function and Fail-Safe Clock Monitor function are disabled. This is the default setting.

The NOSC<2:0> control bits (OSCCON<10:8>) do not control the clock selection when clock switching is disabled. However, the COSC<2:0> bits (OSCCON<14:12>) reflect the clock source selected by the FNOSCx Configuration bits.

The OSWEN control bit (OSCCON<0>) has no effect when clock switching is disabled. It is held at '0' at all times.

8.5.2 OSCILLATOR SWITCHING SEQUENCE

To perform a clock switch, the following basic sequence is required:

1. If required, read the COSC<2:0> bits to determine the current oscillator source.
2. Perform the unlock sequence to allow a write to the OSCCON register high byte.
3. Write the appropriate value to the NOSC<2:0> control bits for the new oscillator source.
4. Perform the unlock sequence to allow a write to the OSCCON register low byte.
5. Set the OSWEN bit to initiate the oscillator switch.

After the basic sequence is completed, the system clock hardware responds as follows:

1. The clock switching hardware compares the COSC<2:0> status bits with the new value of the NOSC<2:0> control bits. If they are the same, the clock switch is a redundant operation. In this case, the OSWEN bit is cleared automatically and the clock switch is aborted.

2. If a valid clock switch has been initiated, the LOCK (OSCCON<5>) and the CF (OSCCON<3>) status bits are cleared.
3. The new oscillator is turned on by the hardware if it is not currently running. If a crystal oscillator must be turned on, the hardware waits until the Oscillator Start-up Timer (OST) expires. If the new source is using the PLL, the hardware waits until a PLL lock is detected (LOCK = 1).
4. The hardware waits for 10 clock cycles from the new clock source and then performs the clock switch.
5. The hardware clears the OSWEN bit to indicate a successful clock transition. In addition, the NOSC<2:0> bit values are transferred to the COSC<2:0> status bits.
6. The old clock source is turned off at this time, with the exception of LPRC (if WDT or FSCM are enabled).

Note 1: The processor continues to execute code throughout the clock switching sequence. Timing-sensitive code should not be executed during this time.

- 2: Direct clock switches between any primary oscillator mode with PLL and FRCPLL mode are not permitted. This applies to clock switches in either direction. In these instances, the application must switch to FRC mode as a transition clock source between the two PLL modes.
- 3: Refer to “**Oscillator (Part IV)**” (DS70307) in the “*dsPIC33F/PIC24H Family Reference Manual*” for details.

8.6 Fail-Safe Clock Monitor (FSCM)

The Fail-Safe Clock Monitor (FSCM) allows the device to continue to operate even in the event of an oscillator failure. The FSCM function is enabled by programming. If the FSCM function is enabled, the LPRC internal oscillator runs at all times (except during Sleep mode) and is not subject to control by the Watchdog Timer.

During an oscillator failure, the FSCM generates a clock failure trap event and switches the system clock over to the FRC oscillator. Then, the application program can either attempt to restart the oscillator or execute a controlled shutdown. The trap can be treated as a Warm Reset by simply loading the Reset address into the oscillator fail trap vector.

If the PLL multiplier is used to scale the system clock, the internal FRC is also multiplied by the same factor on clock failure. Essentially, the device switches to FRC with PLL on a clock failure.

9.0 POWER-SAVING FEATURES

Note 1: This data sheet summarizes the features of the dsPIC33FJ06GS101/X02 and dsPIC33FJ16GSX02/X04 families of devices. It is not intended to be a comprehensive reference source. To complement the information in this data sheet, refer to “**Watchdog Timer and Power-Saving Modes**” (DS70196) in the “*dsPIC33F/PIC24H Family Reference Manual*”, which is available from the Microchip web site (www.microchip.com).

2: Some registers and associated bits described in this section may not be available on all devices. Refer to [Section 4.0 “Memory Organization”](#) in this data sheet for device-specific register and bit information.

The dsPIC33FJ06GS101/X02 and dsPIC33FJ16GSX02/X04 devices provide the ability to manage power consumption by selectively managing clocking to the CPU and the peripherals. In general, a lower clock frequency and a reduction in the number of circuits being clocked constitutes lower consumed power. dsPIC33FJ06GS101/X02 and dsPIC33FJ16GSX02/X04 devices can manage power consumption in four different ways:

- Clock Frequency
- Instruction-Based Sleep and Idle modes
- Software-Controlled Doze mode
- Selective Peripheral Control in Software

Combinations of these methods can be used to selectively tailor an application’s power consumption while still maintaining critical application features, such as timing-sensitive communications.

9.1 Clock Frequency and Clock Switching

The dsPIC33FJ06GS101/X02 and dsPIC33FJ16GSX02/X04 devices allow a wide range of clock frequencies to be selected under application control. If the system clock configuration is not locked, users can choose low-power or high-precision oscillators by simply changing the NOSC<2:0> bits (OSCCON<10:8>). The process of changing a system clock during operation, as well as limitations to the process, are discussed in more detail in [Section 8.0 “Oscillator Configuration”](#).

EXAMPLE 9-1: PWRSAV INSTRUCTION SYNTAX

```
PWRSAV #SLEEP_MODE ; Put the device into SLEEP mode
PWRSAV #IDLE_MODE ; Put the device into IDLE mode
```

9.2 Instruction-Based Power-Saving Modes

The dsPIC33FJ06GS101/X02 and dsPIC33FJ16GSX02/X04 devices have two special power-saving modes that are entered through the execution of a special PWRSAV instruction. Sleep mode stops clock operation and halts all code execution. Idle mode halts the CPU and code execution, but allows peripheral modules to continue operation. The assembler syntax of the PWRSAV instruction is shown in [Example 9-1](#).

Note: SLEEP_MODE and IDLE_MODE are constants defined in the assembler include file for the selected device.

Sleep and Idle modes can be exited as a result of an enabled interrupt, WDT time-out or a device Reset. When the device exits these modes, it is said to wake-up.

9.2.1 SLEEP MODE

The following occur in Sleep mode:

- The system clock source is shut down. If an on-chip oscillator is used, it is turned off
- The device current consumption is reduced to a minimum, provided that no I/O pin is sourcing current
- The Fail-Safe Clock Monitor does not operate, since the system clock source is disabled
- The LPRC clock continues to run in Sleep mode if the WDT is enabled
- The WDT, if enabled, is automatically cleared prior to entering Sleep mode
- Some device features or peripherals may continue to operate. This includes the items such as the Input Change Notification on the I/O ports or peripherals that use an external clock input.
- Any peripheral that requires the system clock source for its operation is disabled

The device will wake-up from Sleep mode on any of these events:

- Any interrupt source that is individually enabled
- Any form of device Reset
- A WDT time-out

On wake-up from Sleep mode, the processor restarts with the same clock source that was active when Sleep mode was entered.

dsPIC33FJ06GS101/X02 and dsPIC33FJ16GSX02/X04

9.2.2 IDLE MODE

The following occur in Idle mode:

- The CPU stops executing instructions
- The WDT is automatically cleared
- The system clock source remains active. By default, all peripheral modules continue to operate normally from the system clock source, but can also be selectively disabled (see [Section 9.4 “Peripheral Module Disable”](#)).
- If the WDT or FSCM is enabled, the LPRC also remains active

The device will wake-up from Idle mode on any of these events:

- Any interrupt that is individually enabled
- Any device Reset
- A WDT time-out

On wake-up from Idle mode, the clock is reapplied to the CPU and instruction execution will begin (2-4 clock cycles later), starting with the instruction following the `PWRSVAV` instruction, or the first instruction in the ISR.

9.2.3 INTERRUPTS COINCIDENT WITH POWER SAVE INSTRUCTIONS

Any interrupt that coincides with the execution of a `PWRSVAV` instruction is held off until entry into Sleep or Idle mode has completed. The device then wakes up from Sleep or Idle mode.

9.3 Doze Mode

The preferred strategies for reducing power consumption are changing clock speed and invoking one of the power-saving modes. In some circumstances, this may not be practical. For example, it may be necessary for an application to maintain uninterrupted synchronous communication, even while it is doing nothing else. Reducing system clock speed can introduce communication errors, while using a power-saving mode can stop communications completely.

Doze mode is a simple and effective alternative method to reduce power consumption while the device is still executing code. In this mode, the system clock continues to operate from the same source and at the same speed. Peripheral modules continue to be clocked at the same speed, while the CPU clock speed is reduced. Synchronization between the two clock domains is maintained, allowing the peripherals to access the SFRs while the CPU executes code at a slower rate.

Doze mode is enabled by setting the DOZEN bit (`CLKDIV<11>`). The ratio between peripheral and core clock speed is determined by the `DOZE<2:0>` bits (`CLKDIV<14:12>`). There are eight possible configurations, from 1:1 to 1:128, with 1:1 being the default setting.

Programs can use Doze mode to selectively reduce power consumption in event-driven applications. This allows clock-sensitive functions, such as synchronous communications, to continue without interruption while the CPU idles, waiting for something to invoke an interrupt routine. An automatic return to full-speed CPU operation on interrupts can be enabled by setting the ROI bit (`CLKDIV<15>`). By default, interrupt events have no effect on Doze mode operation.

For example, suppose the device is operating at 20 MIPS and the CAN module has been configured for 500 kbps based on this device operating speed. If the device is placed in Doze mode with a clock frequency ratio of 1:4, the CAN module continues to communicate at the required bit rate of 500 kbps, but the CPU now starts executing instructions at a frequency of 5 MIPS.

9.4 Peripheral Module Disable

The Peripheral Module Disable (PMD) registers provide a method to disable a peripheral module by stopping all clock sources supplied to that module. When a peripheral is disabled using the appropriate PMD control bit, the peripheral is in a minimum power consumption state. The control and status registers associated with the peripheral are also disabled, so writes to those registers will have no effect and read values will be invalid.

A peripheral module is enabled only if both the associated bit in the PMD register is cleared and the peripheral is supported by the specific dsPIC® DSC variant. If the peripheral is present in the device, it is enabled in the PMD register by default.

Note: If a PMD bit is set, the corresponding module is disabled after a delay of one instruction cycle. Similarly, if a PMD bit is cleared, the corresponding module is enabled after a delay of one instruction cycle (assuming the module control registers are already configured to enable module operation).

dsPIC33FJ06GS101/X02 and dsPIC33FJ16GSX02/X04

REGISTER 9-1: PMD1: PERIPHERAL MODULE DISABLE CONTROL REGISTER 1

U-0	U-0	R/W-0	R/W-0	R/W-0	U-0	R/W-0	U-0
—	—	T3MD	T2MD	T1MD	—	PWMMD ⁽¹⁾	—
bit 15						bit 8	

R/W-0	U-0	R/W-0	U-0	R/W-0	U-0	U-0	R/W-0
I2C1MD	—	U1MD	—	SPI1MD	—	—	ADCMD
bit 7						bit 0	

Legend:

R = Readable bit W = Writable bit U = Unimplemented bit, read as '0'
 -n = Value at POR '1' = Bit is set '0' = Bit is cleared x = Bit is unknown

- bit 15-14 **Unimplemented:** Read as '0'
- bit 13 **T3MD:** Timer3 Module Disable bit
 1 = Timer3 module is disabled
 0 = Timer3 module is enabled
- bit 12 **T2MD:** Timer2 Module Disable bit
 1 = Timer2 module is disabled
 0 = Timer2 module is enabled
- bit 11 **T1MD:** Timer1 Module Disable bit
 1 = Timer1 module is disabled
 0 = Timer1 module is enabled
- bit 10 **Unimplemented:** Read as '0'
- bit 9 **PWMMD:** PWM Module Disable bit⁽¹⁾
 1 = PWM module is disabled
 0 = PWM module is enabled
- bit 8 **Unimplemented:** Read as '0'
- bit 7 **I2C1MD:** I2C1 Module Disable bit
 1 = I2C1 module is disabled
 0 = I2C1 module is enabled
- bit 6 **Unimplemented:** Read as '0'
- bit 5 **U1MD:** UART1 Module Disable bit
 1 = UART1 module is disabled
 0 = UART1 module is enabled
- bit 4 **Unimplemented:** Read as '0'
- bit 3 **SPI1MD:** SPI1 Module Disable bit
 1 = SPI1 module is disabled
 0 = SPI1 module is enabled
- bit 2-1 **Unimplemented:** Read as '0'
- bit 0 **ADCMD:** ADC Module Disable bit
 1 = ADC module is disabled
 0 = ADC module is enabled

Note 1: Once the PWM module is re-enabled (PWMMD is set to '1' and then set to '0'), all PWM registers must be reinitialized.

dsPIC33FJ06GS101/X02 and dsPIC33FJ16GSX02/X04

REGISTER 9-2: PMD2: PERIPHERAL MODULE DISABLE CONTROL REGISTER 2

U-0	U-0	U-0	U-0	U-0	U-0	R/W-0	R/W-0
—	—	—	—	—	—	IC2MD	IC1MD
bit 15						bit 8	

U-0	U-0	U-0	U-0	U-0	U-0	R/W-0	R/W-0
—	—	—	—	—	—	OC2MD	OC1MD
bit 7						bit 0	

Legend:

R = Readable bit

W = Writable bit

U = Unimplemented bit, read as '0'

-n = Value at POR

'1' = Bit is set

'0' = Bit is cleared

x = Bit is unknown

bit 15-10 **Unimplemented:** Read as '0'

bit 9 **IC2MD:** Input Capture 2 Module Disable bit

1 = Input Capture 2 module is disabled

0 = Input Capture 2 module is enabled

bit 8 **IC1MD:** Input Capture 1 Module Disable bit

1 = Input Capture 1 module is disabled

0 = Input Capture 1 module is enabled

bit 7-2 **Unimplemented:** Read as '0'

bit 1 **OC2MD:** Output Compare 2 Module Disable bit

1 = Output Compare 2 module is disabled

0 = Output Compare 2 module is enabled

bit 0 **OC1MD:** Output Compare 1 Module Disable bit

1 = Output Compare 1 module is disabled

0 = Output Compare 1 module is enabled

dsPIC33FJ06GS101/X02 and dsPIC33FJ16GSX02/X04

REGISTER 9-3: PMD3: PERIPHERAL MODULE DISABLE CONTROL REGISTER 3

U-0	U-0	U-0	U-0	U-0	R/W-0	U-0	U-0
—	—	—	—	—	CMPMD	—	—
bit 15						bit 8	

U-0	U-0	U-0	U-0	U-0	U-0	U-0	U-0
—	—	—	—	—	—	—	—
bit 7						bit 0	

Legend:

R = Readable bit W = Writable bit U = Unimplemented bit, read as '0'
 -n = Value at POR '1' = Bit is set '0' = Bit is cleared x = Bit is unknown

- bit 15-11 **Unimplemented:** Read as '0'
- bit 10 **CMPMD:** Analog Comparator Module Disable bit
 1 = Analog comparator module is disabled
 0 = Analog comparator module is enabled
- bit 9-0 **Unimplemented:** Read as '0'

REGISTER 9-4: PMD4: PERIPHERAL MODULE DISABLE CONTROL REGISTER 4

U-0	U-0	U-0	U-0	U-0	U-0	U-0	U-0
—	—	—	—	—	—	—	—
bit 15						bit 8	

U-0	U-0	U-0	U-0	R/W-0	U-0	U-0	U-0
—	—	—	—	REFOMD	—	—	—
bit 7						bit 0	

Legend:

R = Readable bit W = Writable bit U = Unimplemented bit, read as '0'
 -n = Value at POR '1' = Bit is set '0' = Bit is cleared x = Bit is unknown

- bit 15-4 **Unimplemented:** Read as '0'
- bit 3 **REFOMD:** Reference Clock Generator Module Disable bit
 1 = Reference clock generator module is disabled
 0 = Reference clock generator module is enabled
- bit 2-0 **Unimplemented:** Read as '0'

dsPIC33FJ06GS101/X02 and dsPIC33FJ16GSX02/X04

REGISTER 9-5: PMD6: PERIPHERAL MODULE DISABLE CONTROL REGISTER 6

U-0	U-0	U-0	U-0	R/W-0	R/W-0	R/W-0	R/W-0
—	—	—	—	PWM4MD	PWM3MD	PWM2MD	PWM1MD
bit 15							bit 8

U-0	U-0	U-0	U-0	U-0	U-0	U-0	U-0
—	—	—	—	—	—	—	—
bit 7							bit 0

Legend:

R = Readable bit W = Writable bit U = Unimplemented bit, read as '0'
 -n = Value at POR '1' = Bit is set '0' = Bit is cleared x = Bit is unknown

- bit 15-12 **Unimplemented:** Read as '0'
- bit 11 **PWM4MD:** PWM Generator 4 Module Disable bit
 1 = PWM Generator 4 module is disabled
 0 = PWM Generator 4 module is enabled
- bit 10 **PWM3MD:** PWM Generator 3 Module Disable bit
 1 = PWM Generator 3 module is disabled
 0 = PWM Generator 3 module is enabled
- bit 9 **PWM2MD:** PWM Generator 2 Module Disable bit
 1 = PWM Generator 2 module is disabled
 0 = PWM Generator 2 module is enabled
- bit 8 **PWM1MD:** PWM Generator 1 Module Disable bit
 1 = PWM Generator 1 module is disabled
 0 = PWM Generator 1 module is enabled
- bit 7-0 **Unimplemented:** Read as '0'

dsPIC33FJ06GS101/X02 and dsPIC33FJ16GSX02/X04

REGISTER 9-6: PMD7: PERIPHERAL MODULE DISABLE CONTROL REGISTER 7

U-0	U-0	U-0	U-0	R/W-0	R/W-0	R/W-0	R/W-0
—	—	—	—	CMP4MD	CMP3MD	CMP2MD	CMP1MD
bit 15							bit 8

U-0	U-0	U-0	U-0	U-0	U-0	U-0	U-0
—	—	—	—	—	—	—	—
bit 7							bit 0

Legend:

R = Readable bit W = Writable bit U = Unimplemented bit, read as '0'
-n = Value at POR '1' = Bit is set '0' = Bit is cleared x = Bit is unknown

- bit 15-12 **Unimplemented:** Read as '0'
- bit 11 **CMP4MD:** Analog Comparator 4 Module Disable bit
 1 = Analog Comparator 4 module is disabled
 0 = Analog Comparator 4 module is enabled
- bit 10 **CMP3MD:** Analog Comparator 3 Module Disable bit
 1 = Analog Comparator 3 module is disabled
 0 = Analog Comparator 3 module is enabled
- bit 9 **CMP2MD:** Analog Comparator 2 Module Disable bit
 1 = Analog Comparator 2 module is disabled
 0 = Analog Comparator 2 module is enabled
- bit 8 **CMP1MD:** Analog Comparator 1 Module Disable bit
 1 = Analog Comparator 1 module is disabled
 0 = Analog Comparator 1 module is enabled
- bit 7-0 **Unimplemented:** Read as '0'

dsPIC33FJ06GS101/X02 and dsPIC33FJ16GSX02/X04

NOTES:

dsPIC33FJ06GS101/X02 and dsPIC33FJ16GSX02/X04

10.0 I/O PORTS

Note 1: This data sheet summarizes the features of the dsPIC33FJ06GS101/X02 and dsPIC33FJ16GSX02/X04 families of devices. It is not intended to be a comprehensive reference source. To complement the information in this data sheet, refer to “I/O Ports” (DS70193) in the “dsPIC33F/PIC24H Family Reference Manual”, which is available on Microchip web site (www.microchip.com).

2: Some registers and associated bits described in this section may not be available on all devices. Refer to [Section 4.0 “Memory Organization”](#) in this data sheet for device-specific register and bit information.

All of the device pins (except VDD, VSS, MCLR and OSC1/CLKI) are shared among the peripherals and the parallel I/O ports. All I/O input ports feature Schmitt Trigger inputs for improved noise immunity.

10.1 Parallel I/O (PIO) Ports

Generally a parallel I/O port that shares a pin with a peripheral is subservient to the peripheral. The peripheral’s output buffer data and control signals are provided to a pair of multiplexers. The multiplexers select whether the peripheral or the associated port

has ownership of the output data and control signals of the I/O pin. The logic also prevents “loop through”, in which a port’s digital output can drive the input of a peripheral that shares the same pin. [Figure 10-1](#) shows how ports are shared with other peripherals and the associated I/O pin to which they are connected.

When a peripheral is enabled and the peripheral is actively driving an associated pin, the use of the pin as a general purpose output pin is disabled. The I/O pin can be read, but the output driver for the parallel port bit is disabled. If a peripheral is enabled, but the peripheral is not actively driving a pin, that pin can be driven by a port.

All port pins have three registers directly associated with their operation as digital I/O. The data direction register (TRISx) determines whether the pin is an input or an output. If the data direction bit is ‘1’, then the pin is an input. All port pins are defined as inputs after a Reset. Reads from the latch (LATx) read the latch. Writes to the latch write the latch. Reads from the port (PORTx) read the port pins, while writes to the port pins write the latch.

Any bit and its associated data and control registers that are not valid for a particular device will be disabled. That means the corresponding LATx and TRISx registers and the port pin will read as zeros.

When a pin is shared with another peripheral or function that is defined as an input only, it is nevertheless regarded as a dedicated port because there is no other competing source of outputs.

FIGURE 10-1: BLOCK DIAGRAM OF A TYPICAL SHARED PORT STRUCTURE



dsPIC33FJ06GS101/X02 and dsPIC33FJ16GSX02/X04

10.2 Open-Drain Configuration

In addition to the PORTx, LATx and TRISx registers for data control, some digital-only port pins can also be individually configured for either digital or open-drain output. This is controlled by the Open-Drain Control register, ODCx, associated with each port. Setting any of the bits configures the corresponding pin to act as an open-drain output.

The open-drain feature allows the generation of outputs higher than VDD (for example, 5V) on any desired 5V tolerant pins by using external pull-up resistors. The maximum open-drain voltage allowed is the same as the maximum VIH specification.

Refer to “[Pin Diagrams](#)” for the available pins and their functionality.

10.3 Configuring Analog Port Pins

The ADPCFG and TRISx registers control the operation of the Analog-to-Digital (A/D) port pins. The port pins that are to function as analog inputs must have their corresponding TRISx bit set (input). If the TRISx bit is cleared (output), the digital output level (VOH or VOL) will be converted.

The ADPCFG register has a default value of 0x0000; therefore, all pins that share ANx functions are analog (not digital) by default.

When the PORTx register is read, all pins configured as analog input channels will read as cleared (a low level).

Pins configured as digital inputs will not convert an analog input. Analog levels on any pin defined as a digital input (including the ANx pins) can cause the input buffer to consume current that exceeds the device specifications.

10.4 I/O Port Write/Read Timing

One instruction cycle is required between a port direction change or port write operation and a read operation of the same port. Typically, this instruction would be a NOP. An example is shown in [Example 10-1](#).

10.5 Input Change Notification

The Input Change Notification (ICN) function of the I/O ports allows the dsPIC33FJ06GS101/X02 and dsPIC33FJ16GSX02/X04 devices to generate interrupt requests to the processor in response to a Change-of-State (COS) on selected input pins. This feature can detect input Change-of-States even in Sleep mode, when the clocks are disabled. Depending on the device pin count, up to 30 external signals (CNx pin) can be selected (enabled) for generating an interrupt request on a Change-of-State.

Four control registers are associated with the CN module. The CNEN1 and CNEN2 registers contain the interrupt enable control bits for each of the CN input pins. Setting any of these bits enables a CN interrupt for the corresponding pins.

Each CN pin also has a weak pull-up connected to it. The pull-ups act as a current source connected to the pin, and eliminate the need for external resistors when the push button or keypad devices are connected. The pull-ups are enabled separately using the CNPU1 and CNPU2 registers, which contain the control bits for each of the CN pins. Setting any of the control bits enables the weak pull-ups for the corresponding pins.

Note: Pull-ups on Change Notification pins should always be disabled when the port pin is configured as a digital output.

EQUATION 10-1: PORT WRITE/READ EXAMPLE

```
MOV    0xFF00, W0           ; Configure PORTB<15:8> as inputs
MOV    W0, TRISBB          ; and PORTB<7:0> as outputs
NOP                               ; Delay 1 cycle
BTSS   PORTB, #13          ; Next Instruction
```

10.6 Peripheral Pin Select

Peripheral Pin Select configuration enables peripheral set selection and placement on a wide range of I/O pins. By increasing the pinout options available on a particular device, programmers can better tailor the microcontroller to their entire application, rather than trimming the application to fit the device.

The Peripheral Pin Select configuration feature operates over a fixed subset of digital I/O pins. Programmers can independently map the input and/or output of most digital peripherals to any one of these I/O pins. Peripheral Pin Select is performed in software, and generally does not require the device to be reprogrammed. Hardware safeguards are included that prevent accidental or spurious changes to the peripheral mapping, once it has been established.

10.6.1 AVAILABLE PINS

The Peripheral Pin Select feature is used with a range of up to 30 pins. The number of available pins depends on the particular device and its pin count. Pins that support the Peripheral Pin Select feature include the designation “RPn” in their full pin designation, where “RP” designates a remappable peripheral and “n” is the remappable pin number.

10.6.2 CONTROLLING PERIPHERAL PIN SELECT

Peripheral Pin Select features are controlled through two sets of Special Function Registers: one to map peripheral inputs and another one to map outputs. Because they are separately controlled, a particular peripheral’s input and output (if the peripheral has both) can be placed on any selectable function pin without constraint.

The association of a peripheral to a peripheral selectable pin is handled in two different ways, depending on whether an input or output is being mapped.

10.6.2.1 Input Mapping

The inputs of the Peripheral Pin Select options are mapped on the basis of the peripheral. A control register associated with a peripheral dictates the pin it will be mapped to. The RPINRx registers are used to configure peripheral input mapping (see [Register 10-1](#) through [Register 10-14](#)). Each register contains sets of 6-bit fields, with each set associated with one of the remappable peripherals. Programming a given peripheral’s bit field with an appropriate 6-bit value maps the RPn pin with that value to that peripheral. For any given device, the valid range of values for any bit field corresponds to the maximum number of Peripheral Pin Selections supported by the device.

[Figure 10-2](#) illustrates remappable pin selection for U1RX input.

Note: For input mapping only, the Peripheral Pin Select (PPS) functionality does not have priority over the TRISx settings. Therefore, when configuring the RPx pin for input, the corresponding bit in the TRISx register must also be configured for input (i.e., set to ‘1’).

FIGURE 10-2: REMAPPABLE MUX INPUT FOR U1RX



dsPIC33FJ06GS101/X02 and dsPIC33FJ16GSX02/X04

TABLE 10-1: SELECTABLE INPUT SOURCES (MAPS INPUT TO FUNCTION)

Input Name	Function Name	Register	Configuration Bits
External Interrupt 1	INT1	RPINR0	INT1R<5:0>
External Interrupt 2	INT2	RPINR1	INT2R<5:0>
Timer1 External Clock	T1CK	RPINR2	T1CKR<5:0>
Timer2 External Clock	T2CK	RPINR3	T2CKR<5:0>
Timer3 External Clock	T3CK	RPINR3	T3CKR<5:0>
Input Capture 1	IC1	RPINR7	IC1R<5:0>
Input Capture 2	IC2	RPINR7	IC2R<5:0>
Output Compare Fault A	OCFA	RPINR11	OCFAR<5:0>
UART1 Receive	U1RX	RPINR18	U1RXR<5:0>
UART1 Clear-to-Send	$\overline{U1CTS}$	RPINR18	U1CTS<5:0>
SPI Data Input 1	SDI1	RPINR20	SDI1R<5:0>
SPI Clock Input 1	SCK1	RPINR20	SCK1R<5:0>
SPI Slave Select Input 1	$\overline{SS1}$	RPINR21	SS1R<5:0>
PWM Fault Input PWM1	FLT1	RPINR29	FLT1R<5:0>
PWM Fault Input PWM2	FLT2	RPINR30	FLT2R<5:0>
PWM Fault Input PWM3	FLT3	RPINR30	FLT3R<5:0>
PWM Fault Input PWM4	FLT4	RPINR31	FLT4R<5:0>
PWM Fault Input PWM5	FLT5	RPINR31	FLT5R<5:0>
PWM Fault Input PWM6	FLT6	RPINR32	FLT6R<5:0>
PWM Fault Input PWM7	FLT7	RPINR32	FLT7R<5:0>
PWM Fault Input PWM8	FLT8	RPINR33	FLT8R<5:0>
External Synchronization signal to PWM Master Time Base	SYNCI1	RPINR33	SYNCI1R<5:0>
External Synchronization signal to PWM Master Time Base	SYNCI2	RPINR34	SYNCI2R<5:0>

dsPIC33FJ06GS101/X02 and dsPIC33FJ16GSX02/X04

10.6.2.2 Output Mapping

In contrast to inputs, the outputs of the Peripheral Pin Select options are mapped on the basis of the pin. In this case, a control register associated with a particular pin dictates the peripheral output to be mapped. The RPORx registers are used to control output mapping. Like the RPINRx registers, each register contains sets of 6-bit fields, with each set associated with one RPn pin (see [Register 10-15](#) through [Register 10-31](#)). The value of the bit field corresponds to one of the peripherals, and that peripheral's output is mapped to the pin (see [Table 10-2](#) and [Figure 10-3](#)).

The list of peripherals for output mapping also includes a null value of '00000' because of the mapping technique. This permits any given pin to remain unconnected from the output of any of the pin selectable peripherals.

FIGURE 10-3: MULTIPLEXING OF REMAPPABLE OUTPUT FOR RPn



TABLE 10-2: OUTPUT SELECTION FOR REMAPPABLE PIN (RPn)

Function	RPORn<5:0>	Output Name
NULL	000000	RPn tied to default port pin
U1TX	000011	RPn tied to UART1 transmit
U1RTS	000100	RPn tied to UART1 Ready-to-Send
SDO1	000111	RPn tied to SPI1 data output
SCK1	001000	RPn tied to SPI1 clock output
SS1	001001	RPn tied to SPI1 slave select output
OC1	010010	RPn tied to Output Compare 1
OC2	010011	RPn tied to Output Compare 2
SYNCO1	100101	RPn tied to external device synchronization signal via PWM master time base
REFCLKO	100110	REFCLK output signal
ACMP1	100111	RPn tied to Analog Comparator Output 1
ACMP2	101000	RPn tied to Analog Comparator Output 2
ACMP3	101001	RPn tied to Analog Comparator Output 3
ACMP4	101010	RPn tied to Analog Comparator Output 4
PWM4H	101100	RPn tied to PWM output pins associated with PWM Generator 4
PWM4L	101101	RPn tied to PWM output pins associated with PWM Generator 4

dsPIC33FJ06GS101/X02 and dsPIC33FJ16GSX02/X04

10.6.2.3 Virtual Pins

dsPIC33FJ06GS101/X02 and dsPIC33FJ16GSX02/X04 devices support four virtual RPn pins (RP32, RP33, RP34 and RP35), which are identical in functionality to all other RPn pins, with the exception of pinouts. These four pins are internal to the devices and are not connected to a physical device pin.

These pins provide a simple way for inter-peripheral connection without utilizing a physical pin. For example, the output of the analog comparator can be connected to RP32 and the PWM Fault input can be configured for RP32 as well. This configuration allows the analog comparator to trigger PWM Faults without the use of an actual physical pin on the device.

10.6.3 CONTROLLING CONFIGURATION CHANGES

Because peripheral remapping can be changed during run time, some restrictions on peripheral remapping are needed to prevent accidental configuration changes. dsPIC33F devices include three features to prevent alterations to the peripheral map:

- Control register lock sequence
- Continuous state monitoring
- Configuration bit pin select lock

10.6.3.1 Control Register Lock

Under normal operation, writes to the RPINRx and RPORx registers are not allowed. Attempted writes appear to execute normally, but the contents of the registers remain unchanged. To change these registers, they must be unlocked in hardware. The register lock is controlled by the IOLOCK bit (OSCCON<6>). Setting IOLOCK prevents writes to the control registers; clearing IOLOCK allows writes.

To set or clear IOLOCK, a specific command sequence must be executed:

1. Write 0x46 to OSCCON<7:0>.
2. Write 0x57 to OSCCON<7:0>.
3. Clear (or set) IOLOCK as a single operation.

Note: MPLAB® C30 provides built-in C language functions for unlocking the OSCCON register:

```
__builtin_write_OSCCONL(value)  
__builtin_write_OSCCONH(value)
```

See the MPLAB C30 Help files for more information.

Unlike the similar sequence with the oscillator's LOCK bit, IOLOCK remains in one state until changed. This allows all of the Peripheral Pin Selects to be configured with a single unlock sequence followed by an update to all control registers, then locked with a second lock sequence.

10.6.3.2 Continuous State Monitoring

In addition to being protected from direct writes, the contents of the RPINRx and RPORx registers are constantly monitored in hardware by shadow registers. If an unexpected change in any of the registers occurs (such as cell disturbances caused by ESD or other external events), a Configuration Mismatch Reset will be triggered.

10.6.3.3 Configuration Bit Pin Select Lock

As an additional level of safety, the device can be configured to prevent many write session to the RPINRx and RPORx registers. The IOL1WAY (FOSC<5>) Configuration bit blocks the IOLOCK bit from being cleared after it has been set once. If IOLOCK remains set, the register unlock procedure will not execute and the Peripheral Pin Select Control registers cannot be written to. The only way to clear the bit and re-enable peripheral remapping is to perform a device Reset.

In the default (unprogrammed) state, IOL1WAY is set, restricting users to one write session. Programming IOL1WAY allows user applications unlimited access (with the proper use of the unlock sequence) to the Peripheral Pin Select registers.

dsPIC33FJ06GS101/X02 and dsPIC33FJ16GSX02/X04

10.7 Peripheral Pin Select Registers

dsPIC33FJ06GS101/X02 and dsPIC33FJ16GSX02/X04 families of devices implement 34 registers for remappable peripheral configuration:

- 15 Input Remappable Peripheral Registers
- 17 Output Remappable Peripheral Registers

Not all output remappable peripheral registers are implemented on all devices. See the specific register description for further details.

Note: Input and output register values can only be changed if `OSCCON<IOLOCK> = 0`. See [Section 10.6.3.1 “Control Register Lock”](#) for a specific command sequence.

REGISTER 10-1: RPNR0: PERIPHERAL PIN SELECT INPUT REGISTER 0

U-0	U-0	R/W-1	R/W-1	R/W-1	R/W-1	R/W-1	R/W-1
—	—	INT1R5	INT1R4	INT1R3	INT1R2	INT1R1	INT1R0
bit 15						bit 8	

U-0	U-0	U-0	U-0	U-0	U-0	U-0	U-0
—	—	—	—	—	—	—	—
bit 7						bit 0	

Legend:

R = Readable bit	W = Writable bit	U = Unimplemented bit, read as '0'
-n = Value at POR	'1' = Bit is set	'0' = Bit is cleared
		x = Bit is unknown

bit 15-14 **Unimplemented:** Read as '0'

bit 13-8 **INT1R<5:0>:** Assign External Interrupt 1 (INTR1) to the Corresponding RPN Pin bits

- 111111 = Input tied to Vss
- 100011 = Input tied to RP35
- 100010 = Input tied to RP34
- 100001 = Input tied to RP33
- 100000 = Input tied to RP32

-
-
-

00000 = Input tied to RP0

bit 7-0 **Unimplemented:** Read as '0'

dsPIC33FJ06GS101/X02 and dsPIC33FJ16GSX02/X04

REGISTER 10-2: RPINR1: PERIPHERAL PIN SELECT INPUT REGISTER 1

U-0	U-0	U-0	U-0	U-0	U-0	U-0	U-0
—	—	—	—	—	—	—	—
bit 15						bit 8	

U-0	U-0	R/W-1	R/W-1	R/W-1	R/W-1	R/W-1	R/W-1
—	—	INT2R5	INT2R4	INT2R3	INT2R2	INT2R1	INT2R0
bit 7						bit 0	

Legend:

R = Readable bit W = Writable bit U = Unimplemented bit, read as '0'
 -n = Value at POR '1' = Bit is set '0' = Bit is cleared x = Bit is unknown

bit 15-6 **Unimplemented:** Read as '0'

bit 5-0 **INT2R<5:0>:** Assign External Interrupt 2 (INTR2) to the Corresponding RPin Pin bits

- 111111 = Input tied to Vss
- 100011 = Input tied to RP35
- 100010 = Input tied to RP34
- 100001 = Input tied to RP33
- 100000 = Input tied to RP32
-
-
-
- 00000 = Input tied to RP0

dsPIC33FJ06GS101/X02 and dsPIC33FJ16GSX02/X04

REGISTER 10-3: RPINR3: PERIPHERAL PIN SELECT INPUT REGISTER 3

U-0	U-0	R/W-1	R/W-1	R/W-1	R/W-1	R/W-1	R/W-1
—	—	T3CKR5	T3CKR4	T3CKR3	T3CKR2	T3CKR1	T3CKR0
bit 15							bit 8

U-0	U-0	R/W-1	R/W-1	R/W-1	R/W-1	R/W-1	R/W-1
—	—	T2CKR5	T2CKR4	T2CKR3	T2CKR2	T2CKR1	T2CKR0
bit 7							bit 0

Legend:

R = Readable bit W = Writable bit U = Unimplemented bit, read as '0'
 -n = Value at POR '1' = Bit is set '0' = Bit is cleared x = Bit is unknown

bit 15-14 **Unimplemented:** Read as '0'

bit 13-8 **T3CKR<5:0>:** Assign Timer3 External Clock (T3CK) to the Corresponding RPn Pin bits

111111 = Input tied to Vss
 100011 = Input tied to RP35
 100010 = Input tied to RP34
 100001 = Input tied to RP33
 100000 = Input tied to RP32

-
-
-

00000 = Input tied to RP0

bit 7-6 **Unimplemented:** Read as '0'

bit 5-0 **T2CKR<5:0>:** Assign Timer2 External Clock (T2CK) to the Corresponding RPn Pin bits

111111 = Input tied to Vss
 100011 = Input tied to RP35
 100010 = Input tied to RP34
 100001 = Input tied to RP33
 100000 = Input tied to RP32

-
-
-

00000 = Input tied to RP0

dsPIC33FJ06GS101/X02 and dsPIC33FJ16GSX02/X04

REGISTER 10-4: RPINR7: PERIPHERAL PIN SELECT INPUT REGISTER 7

U-0	U-0	R/W-1	R/W-1	R/W-1	R/W-1	R/W-1	R/W-1
—	—	IC2R5	IC2R4	IC2R3	IC2R2	IC2R1	IC2R0
bit 15						bit 8	

U-0	U-0	R/W-1	R/W-1	R/W-1	R/W-1	R/W-1	R/W-1
—	—	IC1R5	IC1R4	IC1R3	IC1R2	IC1R1	IC1R0
bit 7						bit 0	

Legend:

R = Readable bit

W = Writable bit

U = Unimplemented bit, read as '0'

-n = Value at POR

'1' = Bit is set

'0' = Bit is cleared

x = Bit is unknown

bit 15-14 **Unimplemented:** Read as '0'

bit 13-8 **IC2R<5:0>:** Assign Input Capture 2 (IC2) to the Corresponding RPn Pin bits

111111 = Input tied to Vss

100011 = Input tied to RP35

100010 = Input tied to RP34

100001 = Input tied to RP33

100000 = Input tied to RP32

•

•

•

000000 = Input tied to RP0

bit 7-6 **Unimplemented:** Read as '0'

bit 5-0 **IC1R<5:0>:** Assign Input Capture 1 (IC1) to the Corresponding RPn Pin bits

111111 = Input tied to Vss

100011 = Input tied to RP35

100010 = Input tied to RP34

100001 = Input tied to RP33

100000 = Input tied to RP32

•

•

•

000000 = Input tied to RP0

dsPIC33FJ06GS101/X02 and dsPIC33FJ16GSX02/X04

REGISTER 10-5: RPINR11: PERIPHERAL PIN SELECT INPUT REGISTER 11

U-0	U-0	U-0	U-0	U-0	U-0	U-0	U-0
—	—	—	—	—	—	—	—
bit 15						bit 8	

U-0	U-0	R/W-1	R/W-1	R/W-1	R/W-1	R/W-1	R/W-1
—	—	OCFAR5	OCFAR4	OCFAR3	OCFAR2	OCFAR1	OCFAR0
bit 7						bit 0	

Legend:

R = Readable bit W = Writable bit U = Unimplemented bit, read as '0'
 -n = Value at POR '1' = Bit is set '0' = Bit is cleared x = Bit is unknown

bit 15-6 **Unimplemented:** Read as '0'

bit 5-0 **OCFAR<5:0>:** Assign Output Capture A (OCFA) to the Corresponding RPn Pin bits

- 111111 = Input tied to Vss
- 100011 = Input tied to RP35
- 100010 = Input tied to RP34
- 100001 = Input tied to RP33
- 100000 = Input tied to RP32

-
-
-

00000 = Input tied to RP0

dsPIC33FJ06GS101/X02 and dsPIC33FJ16GSX02/X04

REGISTER 10-6: RPINR18: PERIPHERAL PIN SELECT INPUT REGISTER 18

U-0	U-0	R/W-1	R/W-1	R/W-1	R/W-1	R/W-1	R/W-1
—	—	U1CTSR5	U1CTSR4	U1CTSR3	U1CTSR2	U1CTSR1	U1CTSR0
bit 15							bit 8

U-0	U-0	R/W-1	R/W-1	R/W-1	R/W-1	R/W-1	R/W-1
—	—	U1RXR5	U1RXR4	U1RXR3	U1RXR2	U1RXR1	U1RXR0
bit 7							bit 0

Legend:

R = Readable bit	W = Writable bit	U = Unimplemented bit, read as '0'
-n = Value at POR	'1' = Bit is set	'0' = Bit is cleared x = Bit is unknown

bit 15-14 **Unimplemented:** Read as '0'

bit 13-8 **U1CTSR<5:0>:** Assign UART1 Clear-to-Send ($\overline{U1CTS}$) to the Corresponding RPn Pin bits

111111 = Input tied to Vss
 100011 = Input tied to RP35
 100010 = Input tied to RP34
 100001 = Input tied to RP33
 100000 = Input tied to RP32

•
•
•

000000 = Input tied to RP0

bit 7-6 **Unimplemented:** Read as '0'

bit 5-0 **U1RXR<5:0>:** Assign UART1 Receive (U1RX) to the Corresponding RPn Pin bits

111111 = Input tied to Vss
 100011 = Input tied to RP35
 100010 = Input tied to RP34
 100001 = Input tied to RP33
 100000 = Input tied to RP32

•
•
•

000000 = Input tied to RP0

dsPIC33FJ06GS101/X02 and dsPIC33FJ16GSX02/X04

REGISTER 10-7: RPINR20: PERIPHERAL PIN SELECT INPUT REGISTER 20

U-0	U-0	R/W-1	R/W-1	R/W-1	R/W-1	R/W-1	R/W-1
—	—	SCK1R5	SCK1R4	SCK1R3	SCK1R2	SCK1R1	SCK1R0
bit 15							bit 8

U-0	U-0	R/W-1	R/W-1	R/W-1	R/W-1	R/W-1	R/W-1
—	—	SDI1R5	SDI1R4	SDI1R3	SDI1R2	SDI1R1	SDI1R0
bit 7							bit 0

Legend:

R = Readable bit	W = Writable bit	U = Unimplemented bit, read as '0'
-n = Value at POR	'1' = Bit is set	'0' = Bit is cleared
		x = Bit is unknown

bit 15-14 **Unimplemented:** Read as '0'

bit 13-8 **SCK1R<5:0>:** Assign SPI1 Clock Input (SCK1IN) to the Corresponding RPn Pin bits

111111 = Input tied to Vss
 100011 = Input tied to RP35
 100010 = Input tied to RP34
 100001 = Input tied to RP33
 100000 = Input tied to RP32

•
•
•

00000 = Input tied to RP0

bit 7-6 **Unimplemented:** Read as '0'

bit 5-0 **SDI1R<5:0>:** Assign SPI1 Data Input (SDI1) to the Corresponding RPn Pin bits

111111 = Input tied to Vss
 100011 = Input tied to RP35
 100010 = Input tied to RP34
 100001 = Input tied to RP33
 100000 = Input tied to RP32

•
•
•

00000 = Input tied to RP0

dsPIC33FJ06GS101/X02 and dsPIC33FJ16GSX02/X04

REGISTER 10-8: RPINR21: PERIPHERAL PIN SELECT INPUT REGISTER 21

U-0	U-0	U-0	U-0	U-0	U-0	U-0	U-0
—	—	—	—	—	—	—	—
bit 15						bit 8	

U-0	U-0	R/W-1	R/W-1	R/W-1	R/W-1	R/W-1	R/W-1
—	—	SS1R5	SS1R4	SS1R3	SS1R2	SS1R1	SS1R0
bit 7						bit 0	

Legend:

R = Readable bit W = Writable bit U = Unimplemented bit, read as '0'
 -n = Value at POR '1' = Bit is set '0' = Bit is cleared x = Bit is unknown

bit 15-6 **Unimplemented:** Read as '0'

bit 5-0 **SS1R<5:0>:** Assign SPI1 Slave Select Input (SS1IN) to the Corresponding RPn Pin bits

- 111111 = Input tied to Vss
- 100011 = Input tied to RP35
- 100010 = Input tied to RP34
- 100001 = Input tied to RP33
- 100000 = Input tied to RP32
-
-
-
- 000000 = Input tied to RP0

dsPIC33FJ06GS101/X02 and dsPIC33FJ16GSX02/X04

REGISTER 10-9: RPINR29: PERIPHERAL PIN SELECT INPUT REGISTER 29

U-0	U-0	R/W-1	R/W-1	R/W-1	R/W-1	R/W-1	R/W-1
—	—	FLT1R5	FLT1R4	FLT1R3	FLT1R2	FLT1R1	FLT1R0
bit 15							bit 8

U-0	U-0	U-0	U-0	U-0	U-0	U-0	U-0
—	—	—	—	—	—	—	—
bit 7							bit 0

Legend:

R = Readable bit W = Writable bit U = Unimplemented bit, read as '0'
-n = Value at POR '1' = Bit is set '0' = Bit is cleared x = Bit is unknown

bit 15-14 **Unimplemented:** Read as '0'

bit 13-8 **FLT1R<5:0>:** Assign PWM Fault Input 1 (FLT1) to the Corresponding RPn Pin bits

111111 = Input tied to Vss
100011 = Input tied to RP35
100010 = Input tied to RP34
100001 = Input tied to RP33
100000 = Input tied to RP32

-
-
-

00000 = Input tied to RP0

bit 7-0 **Unimplemented:** Read as '0'

dsPIC33FJ06GS101/X02 and dsPIC33FJ16GSX02/X04

REGISTER 10-10: RPINR30: PERIPHERAL PIN SELECT INPUT REGISTER 30

U-0	U-0	R/W-1	R/W-1	R/W-1	R/W-1	R/W-1	R/W-1
—	—	FLT3R5	FLT3R4	FLT3R3	FLT3R2	FLT3R1	FLT3R0
bit 15							bit 8

U-0	U-0	R/W-1	R/W-1	R/W-1	R/W-1	R/W-1	R/W-1
—	—	FLT2R5	FLT2R4	FLT2R3	FLT2R2	FLT2R1	FLT2R0
bit 7							bit 0

Legend:

R = Readable bit	W = Writable bit	U = Unimplemented bit, read as '0'
-n = Value at POR	'1' = Bit is set	'0' = Bit is cleared
		x = Bit is unknown

bit 15-14 **Unimplemented:** Read as '0'

bit 13-8 **FLT3R<5:0>:** Assign PWM Fault Input 3 (FLT3) to the Corresponding RPN Pin bits

111111 = Input tied to Vss
 100011 = Input tied to RP35
 100010 = Input tied to RP34
 100001 = Input tied to RP33
 100000 = Input tied to RP32

•
•
•

00000 = Input tied to RP0

bit 7-6 **Unimplemented:** Read as '0'

bit 5-0 **FLT2R<5:0>:** Assign PWM Fault Input 2 (FLT2) to the Corresponding RPN Pin bits

111111 = Input tied to Vss
 100011 = Input tied to RP35
 100010 = Input tied to RP34
 100001 = Input tied to RP33
 100000 = Input tied to RP32

•
•
•

00000 = Input tied to RP0

dsPIC33FJ06GS101/X02 and dsPIC33FJ16GSX02/X04

REGISTER 10-11: RPINR31: PERIPHERAL PIN SELECT INPUT REGISTER 31

U-0	U-0	R/W-1	R/W-1	R/W-1	R/W-1	R/W-1	R/W-1
—	—	FLT5R5	FLT5R4	FLT5R3	FLT5R2	FLT5R1	FLT5R0
bit 15							bit 8

U-0	U-0	R/W-1	R/W-1	R/W-1	R/W-1	R/W-1	R/W-1
—	—	FLT4R5	FLT4R4	FLT4R3	FLT4R2	FLT4R1	FLT4R0
bit 7							bit 0

Legend:

R = Readable bit	W = Writable bit	U = Unimplemented bit, read as '0'
-n = Value at POR	'1' = Bit is set	'0' = Bit is cleared
		x = Bit is unknown

bit 15-14 **Unimplemented:** Read as '0'

bit 13-8 **FLT5R<5:0>:** Assign PWM Fault Input 5 (FLT5) to the Corresponding RPn Pin bits

111111 = Input tied to Vss
 100011 = Input tied to RP35
 100010 = Input tied to RP34
 100001 = Input tied to RP33
 100000 = Input tied to RP32

•
•
•

00000 = Input tied to RP0

bit 7-6 **Unimplemented:** Read as '0'

bit 5-0 **FLT4R<5:0>:** Assign PWM Fault Input 4 (FLT4) to the Corresponding RPn Pin bits

111111 = Input tied to Vss
 100011 = Input tied to RP35
 100010 = Input tied to RP34
 100001 = Input tied to RP33
 100000 = Input tied to RP32

•
•
•

00000 = Input tied to RP0

dsPIC33FJ06GS101/X02 and dsPIC33FJ16GSX02/X04

REGISTER 10-12: RPINR32: PERIPHERAL PIN SELECT INPUT REGISTER 32

U-0	U-0	R/W-1	R/W-1	R/W-1	R/W-1	R/W-1	R/W-1
—	—	FLT7R5	FLT7R4	FLT7R3	FLT7R2	FLT7R1	FLT7R0
bit 15							bit 8

U-0	U-0	R/W-1	R/W-1	R/W-1	R/W-1	R/W-1	R/W-1
—	—	FLT6R5	FLT6R4	FLT6R3	FLT6R2	FLT6R1	FLT6R0
bit 7							bit 0

Legend:

R = Readable bit W = Writable bit U = Unimplemented bit, read as '0'
 -n = Value at POR '1' = Bit is set '0' = Bit is cleared x = Bit is unknown

bit 15-14 **Unimplemented:** Read as '0'

bit 13-8 **FLT7R<5:0>:** Assign PWM Fault Input 7 (FLT7) to the Corresponding RPn Pin bits

111111 = Input tied to Vss
 100011 = Input tied to RP35
 100010 = Input tied to RP34
 100001 = Input tied to RP33
 100000 = Input tied to RP32

•
 •
 •

00000 = Input tied to RP0

bit 7-6 **Unimplemented:** Read as '0'

bit 5-0 **FLT6R<5:0>:** Assign PWM Fault Input 6 (FLT6) to the Corresponding RPn Pin bits

111111 = Input tied to Vss
 100011 = Input tied to RP35
 100010 = Input tied to RP34
 100001 = Input tied to RP33
 100000 = Input tied to RP32

•
 •
 •

00000 = Input tied to RP0

dsPIC33FJ06GS101/X02 and dsPIC33FJ16GSX02/X04

REGISTER 10-13: RPINR33: PERIPHERAL PIN SELECT INPUT REGISTER 33

U-0	U-0	R/W-1	R/W-1	R/W-1	R/W-1	R/W-1	R/W-1
—	—	SYNCI1R5	SYNCI1R4	SYNCI1R3	SYNCI1R2	SYNCI1R1	SYNCI1R0
bit 15							bit 8

U-0	U-0	R/W-1	R/W-1	R/W-1	R/W-1	R/W-1	R/W-1
—	—	FLT8R5	FLT8R4	FLT8R3	FLT8R2	FLT8R1	FLT8R0
bit 7							bit 0

Legend:

R = Readable bit W = Writable bit U = Unimplemented bit, read as '0'
 -n = Value at POR '1' = Bit is set '0' = Bit is cleared x = Bit is unknown

bit 15-14 **Unimplemented:** Read as '0'

bit 13-8 **SYNCI1R<5:0>:** Assign PWM Master Time Base External Synchronization Signal to the Corresponding RPn Pin bits

111111 = Input tied to Vss
 100011 = Input tied to RP35
 100010 = Input tied to RP34
 100001 = Input tied to RP33
 100000 = Input tied to RP32

•
 •
 •

00000 = Input tied to RP0

bit 7-6 **Unimplemented:** Read as '0'

bit 5-0 **FLT8R<5:0>:** Assign PWM Fault Input 8 (FLT8) to the Corresponding RPn Pin bits

111111 = Input tied to Vss
 100011 = Input tied to RP35
 100010 = Input tied to RP34
 100001 = Input tied to RP33
 100000 = Input tied to RP32

•
 •
 •

00000 = Input tied to RP0

dsPIC33FJ06GS101/X02 and dsPIC33FJ16GSX02/X04

REGISTER 10-14: RPINR34: PERIPHERAL PIN SELECT INPUT REGISTER 34

U-0	U-0	U-0	U-0	U-0	U-0	U-0	U-0
—	—	—	—	—	—	—	—
bit 15							bit 8

U-0	U-0	R/W-1	R/W-1	R/W-1	R/W-1	R/W-1	R/W-1
—	—	SYNCI2R5	SYNCI2R4	SYNCI2R3	SYNCI2R2	SYNCI2R1	SYNCI2R0
bit 7							bit 0

Legend:

R = Readable bit W = Writable bit U = Unimplemented bit, read as '0'
 -n = Value at POR '1' = Bit is set '0' = Bit is cleared x = Bit is unknown

bit 15-6 **Unimplemented:** Read as '0'

bit 5-0 **SYNCI2R<5:0>:** Assign PWM Master Time Base External Synchronization Signal to the Corresponding RPn Pin bits

111111 = Input tied to Vss
 100011 = Input tied to RP35
 100010 = Input tied to RP34
 100001 = Input tied to RP33
 100000 = Input tied to RP32

•
 •
 •

000000 = Input tied to RP0

REGISTER 10-15: RPOR0: PERIPHERAL PIN SELECT OUTPUT REGISTER 0

U-0	U-0	R/W-0	R/W-0	R/W-0	R/W-0	R/W-0	R/W-0
—	—	RP1R5	RP1R4	RP1R3	RP1R2	RP1R1	RP1R0
bit 15							bit 8

U-0	U-0	R/W-0	R/W-0	R/W-0	R/W-0	R/W-0	R/W-0
—	—	RP0R5	RP0R4	RP0R3	RP0R2	RP0R1	RP0R0
bit 7							bit 0

Legend:

R = Readable bit W = Writable bit U = Unimplemented bit, read as '0'
 -n = Value at POR '1' = Bit is set '0' = Bit is cleared x = Bit is unknown

bit 15-14 **Unimplemented:** Read as '0'

bit 13-8 **RP1R<5:0>:** Peripheral Output Function is Assigned to RP1 Output Pin bits (see [Table 10-2](#) for peripheral function numbers)

bit 7-6 **Unimplemented:** Read as '0'

bit 5-0 **RP0R<5:0>:** Peripheral Output Function is Assigned to RP0 Output Pin bits (see [Table 10-2](#) for peripheral function numbers)

dsPIC33FJ06GS101/X02 and dsPIC33FJ16GSX02/X04

REGISTER 10-16: RPOR1: PERIPHERAL PIN SELECT OUTPUT REGISTER 1

U-0	U-0	R/W-0	R/W-0	R/W-0	R/W-0	R/W-0	R/W-0
—	—	RP3R5	RP3R4	RP3R3	RP3R2	RP3R1	RP3R0
bit 15							bit 8

U-0	U-0	R/W-0	R/W-0	R/W-0	R/W-0	R/W-0	R/W-0
—	—	RP2R5	RP2R4	RP2R3	RP2R2	RP2R1	RP2R0
bit 7							bit 0

Legend:

R = Readable bit W = Writable bit U = Unimplemented bit, read as '0'
 -n = Value at POR '1' = Bit is set '0' = Bit is cleared x = Bit is unknown

- bit 15-14 **Unimplemented:** Read as '0'
- bit 13-8 **RP3R<5:0>:** Peripheral Output Function is Assigned to RP3 Output Pin bits
 (see [Table 10-2](#) for peripheral function numbers)
- bit 7-6 **Unimplemented:** Read as '0'
- bit 5-0 **RP2R<5:0>:** Peripheral Output Function is Assigned to RP2 Output Pin bits
 (see [Table 10-2](#) for peripheral function numbers)

REGISTER 10-17: RPOR2: PERIPHERAL PIN SELECT OUTPUT REGISTER 2

U-0	U-0	R/W-0	R/W-0	R/W-0	R/W-0	R/W-0	R/W-0
—	—	RP5R5	RP5R4	RP5R3	RP5R2	RP5R1	RP5R0
bit 15							bit 8

U-0	U-0	R/W-0	R/W-0	R/W-0	R/W-0	R/W-0	R/W-0
—	—	RP4R5	RP4R4	RP4R3	RP4R2	RP4R1	RP4R0
bit 7							bit 0

Legend:

R = Readable bit W = Writable bit U = Unimplemented bit, read as '0'
 -n = Value at POR '1' = Bit is set '0' = Bit is cleared x = Bit is unknown

- bit 15-14 **Unimplemented:** Read as '0'
- bit 13-8 **RP5R<5:0>:** Peripheral Output Function is Assigned to RP5 Output Pin bits
 (see [Table 10-2](#) for peripheral function numbers)
- bit 7-6 **Unimplemented:** Read as '0'
- bit 5-0 **RP4R<5:0>:** Peripheral Output Function is Assigned to RP4 Output Pin bits
 (see [Table 10-2](#) for peripheral function numbers)

dsPIC33FJ06GS101/X02 and dsPIC33FJ16GSX02/X04

REGISTER 10-18: RPOR3: PERIPHERAL PIN SELECT OUTPUT REGISTER 3

U-0	U-0	R/W-0	R/W-0	R/W-0	R/W-0	R/W-0	R/W-0
—	—	RP7R5	RP7R4	RP7R3	RP7R2	RP7R1	RP7R0
bit 15						bit 8	

U-0	U-0	R/W-0	R/W-0	R/W-0	R/W-0	R/W-0	R/W-0
—	—	RP6R5	RP6R4	RP6R3	RP6R2	RP6R1	RP6R0
bit 7						bit 0	

Legend:

R = Readable bit W = Writable bit U = Unimplemented bit, read as '0'
 -n = Value at POR '1' = Bit is set '0' = Bit is cleared x = Bit is unknown

- bit 15-14 **Unimplemented:** Read as '0'
- bit 13-8 **RP7R<5:0>:** Peripheral Output Function is Assigned to RP7 Output Pin bits
 (see [Table 10-2](#) for peripheral function numbers)
- bit 7-6 **Unimplemented:** Read as '0'
- bit 5-0 **RP6R<5:0>:** Peripheral Output Function is Assigned to RP6 Output Pin bits
 (see [Table 10-2](#) for peripheral function numbers)

REGISTER 10-19: RPOR4: PERIPHERAL PIN SELECT OUTPUT REGISTER 4⁽¹⁾

U-0	U-0	R/W-0	R/W-0	R/W-0	R/W-0	R/W-0	R/W-0
—	—	RP9R5	RP9R4	RP9R3	RP9R2	RP9R1	RP9R0
bit 15						bit 8	

U-0	U-0	R/W-0	R/W-0	R/W-0	R/W-0	R/W-0	R/W-0
—	—	RP8R5	RP8R4	RP8R3	RP8R2	RP8R1	RP8R0
bit 7						bit 0	

Legend:

R = Readable bit W = Writable bit U = Unimplemented bit, read as '0'
 -n = Value at POR '1' = Bit is set '0' = Bit is cleared x = Bit is unknown

- bit 15-14 **Unimplemented:** Read as '0'
- bit 13-8 **RP9R<5:0>:** Peripheral Output Function is Assigned to RP9 Output Pin bits
 (see [Table 10-2](#) for peripheral function numbers)
- bit 7-6 **Unimplemented:** Read as '0'
- bit 5-0 **RP8R<5:0>:** Peripheral Output Function is Assigned to RP8 Output Pin bits
 (see [Table 10-2](#) for peripheral function numbers)

Note 1: This register is not implemented in the dsPIC33FJ06GS101 device.

dsPIC33FJ06GS101/X02 and dsPIC33FJ16GSX02/X04

REGISTER 10-20: RPOR5: PERIPHERAL PIN SELECT OUTPUT REGISTER 5⁽¹⁾

U-0	U-0	R/W-0	R/W-0	R/W-0	R/W-0	R/W-0	R/W-0
—	—	RP11R5	RP11R4	RP11R3	RP11R2	RP11R1	RP11R0
bit 15							bit 8

U-0	U-0	R/W-0	R/W-0	R/W-0	R/W-0	R/W-0	R/W-0
—	—	RP10R5	RP10R4	RP10R3	RP10R2	RP10R1	RP10R0
bit 7							bit 0

Legend:

R = Readable bit W = Writable bit U = Unimplemented bit, read as '0'
 -n = Value at POR '1' = Bit is set '0' = Bit is cleared x = Bit is unknown

- bit 15-14 **Unimplemented:** Read as '0'
- bit 13-8 **RP11R<5:0>:** Peripheral Output Function is Assigned to RP11 Output Pin bits
 (see [Table 10-2](#) for peripheral function numbers)
- bit 7-6 **Unimplemented:** Read as '0'
- bit 5-0 **RP10R<5:0>:** Peripheral Output Function is Assigned to RP10 Output Pin bits
 (see [Table 10-2](#) for peripheral function numbers)

Note 1: This register is not implemented in the dsPIC33FJ06GS101 device.

REGISTER 10-21: RPOR6: PERIPHERAL PIN SELECT OUTPUT REGISTER 6⁽¹⁾

U-0	U-0	R/W-0	R/W-0	R/W-0	R/W-0	R/W-0	R/W-0
—	—	RP13R5	RP13R4	RP13R3	RP13R2	RP13R1	RP13R0
bit 15							bit 8

U-0	U-0	R/W-0	R/W-0	R/W-0	R/W-0	R/W-0	R/W-0
—	—	RP12R5	RP12R4	RP12R3	RP12R2	RP12R1	RP12R0
bit 7							bit 0

Legend:

R = Readable bit W = Writable bit U = Unimplemented bit, read as '0'
 -n = Value at POR '1' = Bit is set '0' = Bit is cleared x = Bit is unknown

- bit 15-14 **Unimplemented:** Read as '0'
- bit 13-8 **RP13R<5:0>:** Peripheral Output Function is Assigned to RP13 Output Pin bits
 (see [Table 10-2](#) for peripheral function numbers)
- bit 7-6 **Unimplemented:** Read as '0'
- bit 5-0 **RP12R<5:0>:** Peripheral Output Function is Assigned to RP12 Output Pin bits
 (see [Table 10-2](#) for peripheral function numbers)

Note 1: This register is not implemented in the dsPIC33FJ06GS101 device.

dsPIC33FJ06GS101/X02 and dsPIC33FJ16GSX02/X04

REGISTER 10-22: RPOR7: PERIPHERAL PIN SELECT OUTPUT REGISTER 7⁽¹⁾

U-0	U-0	R/W-0	R/W-0	R/W-0	R/W-0	R/W-0	R/W-0
—	—	RP15R5	RP15R4	RP15R3	RP15R2	RP15R1	RP15R0
bit 15							bit 8

U-0	U-0	R/W-0	R/W-0	R/W-0	R/W-0	R/W-0	R/W-0
—	—	RP14R5	RP14R4	RP14R3	RP14R2	RP14R1	RP14R0
bit 7							bit 0

Legend:

R = Readable bit W = Writable bit U = Unimplemented bit, read as '0'
 -n = Value at POR '1' = Bit is set '0' = Bit is cleared x = Bit is unknown

- bit 15-14 **Unimplemented:** Read as '0'
- bit 13-8 **RP15R<5:0>:** Peripheral Output Function is Assigned to RP15 Output Pin bits
 (see [Table 10-2](#) for peripheral function numbers)
- bit 7-6 **Unimplemented:** Read as '0'
- bit 5-0 **RP14R<5:0>:** Peripheral Output Function is Assigned to RP14 Output Pin bits
 (see [Table 10-2](#) for peripheral function numbers)

Note 1: This register is not implemented in the dsPIC33FJ06GS101 device.

REGISTER 10-23: RPOR8: PERIPHERAL PIN SELECT OUTPUT REGISTER 8⁽¹⁾

U-0	U-0	R/W-0	R/W-0	R/W-0	R/W-0	R/W-0	R/W-0
—	—	RP17R5	RP17R4	RP17R3	RP17R2	RP17R1	RP17R0
bit 15							bit 8

U-0	U-0	R/W-0	R/W-0	R/W-0	R/W-0	R/W-0	R/W-0
—	—	RP16R5	RP16R4	RP16R3	RP16R2	RP16R1	RP16R0
bit 7							bit 0

Legend:

R = Readable bit W = Writable bit U = Unimplemented bit, read as '0'
 -n = Value at POR '1' = Bit is set '0' = Bit is cleared x = Bit is unknown

- bit 15-14 **Unimplemented:** Read as '0'
- bit 13-8 **RP17R<5:0>:** Peripheral Output Function is Assigned to RP17 Output Pin bits
 (see [Table 10-2](#) for peripheral function numbers)
- bit 7-6 **Unimplemented:** Read as '0'
- bit 5-0 **RP16R<5:0>:** Peripheral Output Function is Assigned to RP16 Output Pin bits
 (see [Table 10-2](#) for peripheral function numbers)

Note 1: This register is implemented in the dsPIC33FJ16GS404 and dsPIC33FJ16GS504 devices only.

dsPIC33FJ06GS101/X02 and dsPIC33FJ16GSX02/X04

REGISTER 10-24: RPOR9: PERIPHERAL PIN SELECT OUTPUT REGISTER 9⁽¹⁾

U-0	U-0	R/W-0	R/W-0	R/W-0	R/W-0	R/W-0	R/W-0
—	—	RP19R5	RP19R4	RP19R3	RP19R2	RP19R1	RP19R0
bit 15							bit 8

U-0	U-0	R/W-0	R/W-0	R/W-0	R/W-0	R/W-0	R/W-0
—	—	RP18R5	RP18R4	RP18R3	RP18R2	RP18R1	RP18R0
bit 7							bit 0

Legend:

R = Readable bit W = Writable bit U = Unimplemented bit, read as '0'
 -n = Value at POR '1' = Bit is set '0' = Bit is cleared x = Bit is unknown

- bit 15-14 **Unimplemented:** Read as '0'
- bit 13-8 **RP19R<5:0>:** Peripheral Output Function is Assigned to RP19 Output Pin bits
 (see [Table 10-2](#) for peripheral function numbers)
- bit 7-6 **Unimplemented:** Read as '0'
- bit 5-0 **RP18R<5:0>:** Peripheral Output Function is Assigned to RP18 Output Pin bits
 (see [Table 10-2](#) for peripheral function numbers)

Note 1: This register is implemented in the dsPIC33FJ16GS404 and dsPIC33FJ16GS504 devices only.

REGISTER 10-25: RPOR10: PERIPHERAL PIN SELECT OUTPUT REGISTER 10⁽¹⁾

U-0	U-0	R/W-0	R/W-0	R/W-0	R/W-0	R/W-0	R/W-0
—	—	RP21R5	RP21R4	RP21R3	RP21R2	RP21R1	RP21R0
bit 15							bit 8

U-0	U-0	R/W-0	R/W-0	R/W-0	R/W-0	R/W-0	R/W-0
—	—	RP20R5	RP20R4	RP20R3	RP20R2	RP20R1	RP20R0
bit 7							bit 0

Legend:

R = Readable bit W = Writable bit U = Unimplemented bit, read as '0'
 -n = Value at POR '1' = Bit is set '0' = Bit is cleared x = Bit is unknown

- bit 15-14 **Unimplemented:** Read as '0'
- bit 13-8 **RP21R<5:0>:** Peripheral Output Function is Assigned to RP21 Output Pin bits
 (see [Table 10-2](#) for peripheral function numbers)
- bit 7-6 **Unimplemented:** Read as '0'
- bit 5-0 **RP20R<5:0>:** Peripheral Output Function is Assigned to RP20 Output Pin bits
 (see [Table 10-2](#) for peripheral function numbers)

Note 1: This register is implemented in the dsPIC33FJ16GS404 and dsPIC33FJ16GS504 devices only.

dsPIC33FJ06GS101/X02 and dsPIC33FJ16GSX02/X04

REGISTER 10-26: RPOR11: PERIPHERAL PIN SELECT OUTPUT REGISTER 11⁽¹⁾

U-0	U-0	R/W-0	R/W-0	R/W-0	R/W-0	R/W-0	R/W-0
—	—	RP23R5	RP23R4	RP23R3	RP23R2	RP23R1	RP23R0
bit 15							bit 8

U-0	U-0	R/W-0	R/W-0	R/W-0	R/W-0	R/W-0	R/W-0
—	—	RP22R5	RP22R4	RP22R3	RP22R2	RP22R1	RP22R0
bit 7							bit 0

Legend:

R = Readable bit W = Writable bit U = Unimplemented bit, read as '0'
 -n = Value at POR '1' = Bit is set '0' = Bit is cleared x = Bit is unknown

- bit 15-14 **Unimplemented:** Read as '0'
- bit 13-8 **RP23R<5:0>:** Peripheral Output Function is Assigned to RP23 Output Pin bits
 (see [Table 10-2](#) for peripheral function numbers)
- bit 7-6 **Unimplemented:** Read as '0'
- bit 5-0 **RP22R<5:0>:** Peripheral Output Function is Assigned to RP22 Output Pin bits
 (see [Table 10-2](#) for peripheral function numbers)

Note 1: This register is implemented in the dsPIC33FJ16GS404 and dsPIC33FJ16GS504 devices only.

REGISTER 10-27: RPOR12: PERIPHERAL PIN SELECT OUTPUT REGISTER 12⁽¹⁾

U-0	U-0	R/W-0	R/W-0	R/W-0	R/W-0	R/W-0	R/W-0
—	—	RP25R5	RP25R4	RP25R3	RP25R2	RP25R1	RP25R0
bit 15							bit 8

U-0	U-0	R/W-0	R/W-0	R/W-0	R/W-0	R/W-0	R/W-0
—	—	RP24R5	RP24R4	RP24R3	RP24R2	RP24R1	RP24R0
bit 7							bit 0

Legend:

R = Readable bit W = Writable bit U = Unimplemented bit, read as '0'
 -n = Value at POR '1' = Bit is set '0' = Bit is cleared x = Bit is unknown

- bit 15-14 **Unimplemented:** Read as '0'
- bit 13-8 **RP25R<5:0>:** Peripheral Output Function is Assigned to RP25 Output Pin bits
 (see [Table 10-2](#) for peripheral function numbers)
- bit 7-6 **Unimplemented:** Read as '0'
- bit 5-0 **RP24R<5:0>:** Peripheral Output Function is Assigned to RP24 Output Pin bits
 (see [Table 10-2](#) for peripheral function numbers)

Note 1: This register is implemented in the dsPIC33FJ16GS404 and dsPIC33FJ16GS504 devices only.

dsPIC33FJ06GS101/X02 and dsPIC33FJ16GSX02/X04

REGISTER 10-28: RPOR13: PERIPHERAL PIN SELECT OUTPUT REGISTER 13⁽¹⁾

U-0	U-0	R/W-0	R/W-0	R/W-0	R/W-0	R/W-0	R/W-0
—	—	RP27R5	RP27R4	RP27R3	RP27R2	RP27R1	RP27R0
bit 15							bit 8

U-0	U-0	R/W-0	R/W-0	R/W-0	R/W-0	R/W-0	R/W-0
—	—	RP26R5	RP26R4	RP26R3	RP26R2	RP26R1	RP26R0
bit 7							bit 0

Legend:

R = Readable bit W = Writable bit U = Unimplemented bit, read as '0'
 -n = Value at POR '1' = Bit is set '0' = Bit is cleared x = Bit is unknown

- bit 15-14 **Unimplemented:** Read as '0'
- bit 13-8 **RP27R<5:0>:** Peripheral Output Function is Assigned to RP27 Output Pin bits
 (see [Table 10-2](#) for peripheral function numbers)
- bit 7-6 **Unimplemented:** Read as '0'
- bit 5-0 **RP26R<5:0>:** Peripheral Output Function is Assigned to RP26 Output Pin bits
 (see [Table 10-2](#) for peripheral function numbers)

Note 1: This register is implemented in the dsPIC33FJ16GS404 and dsPIC33FJ16GS504 devices only.

REGISTER 10-29: RPOR14: PERIPHERAL PIN SELECT OUTPUT REGISTER 14⁽¹⁾

U-0	U-0	R/W-0	R/W-0	R/W-0	R/W-0	R/W-0	R/W-0
—	—	RP29R5	RP29R4	RP29R3	RP29R2	RP29R1	RP29R0
bit 15							bit 8

U-0	U-0	R/W-0	R/W-0	R/W-0	R/W-0	R/W-0	R/W-0
—	—	RP28R5	RP28R4	RP28R3	RP28R2	RP28R1	RP28R0
bit 7							bit 0

Legend:

R = Readable bit W = Writable bit U = Unimplemented bit, read as '0'
 -n = Value at POR '1' = Bit is set '0' = Bit is cleared x = Bit is unknown

- bit 15-14 **Unimplemented:** Read as '0'
- bit 13-8 **RP29R<5:0>:** Peripheral Output Function is Assigned to RP29 Output Pin bits
 (see [Table 10-2](#) for peripheral function numbers)
- bit 7-6 **Unimplemented:** Read as '0'
- bit 5-0 **RP28R<5:0>:** Peripheral Output Function is Assigned to RP28 Output Pin bits
 (see [Table 10-2](#) for peripheral function numbers)

Note 1: This register is implemented in the dsPIC33FJ16GS404 and dsPIC33FJ16GS504 devices only.

dsPIC33FJ06GS101/X02 and dsPIC33FJ16GSX02/X04

REGISTER 10-30: RPOR16: PERIPHERAL PIN SELECT OUTPUT REGISTER 16

U-0	U-0	R/W-0	R/W-0	R/W-0	R/W-0	R/W-0	R/W-0
—	—	RP33R5	RP33R4	RP33R3	RP33R2	RP33R1	RP33R0
bit 15							bit 8

U-0	U-0	R/W-0	R/W-0	R/W-0	R/W-0	R/W-0	R/W-0
—	—	RP32R5	RP32R4	RP32R3	RP32R2	RP32R1	RP32R0
bit 7							bit 0

Legend:

R = Readable bit W = Writable bit U = Unimplemented bit, read as '0'
 -n = Value at POR '1' = Bit is set '0' = Bit is cleared x = Bit is unknown

- bit 15-14 **Unimplemented:** Read as '0'
- bit 13-8 **RP33R<5:0>:** Peripheral Output Function is Assigned to RP33 Output Pin bits
 (see [Table 10-2](#) for peripheral function numbers)
- bit 7-6 **Unimplemented:** Read as '0'
- bit 5-0 **RP32R<5:0>:** Peripheral Output Function is Assigned to RP32 Output Pin bits
 (see [Table 10-2](#) for peripheral function numbers)

REGISTER 10-31: RPOR17: PERIPHERAL PIN SELECT OUTPUT REGISTER 17

U-0	U-0	R/W-0	R/W-0	R/W-0	R/W-0	R/W-0	R/W-0
—	—	RP35R5	RP35R4	RP35R3	RP35R2	RP35R1	RP35R0
bit 15							bit 8

U-0	U-0	R/W-0	R/W-0	R/W-0	R/W-0	R/W-0	R/W-0
—	—	RP34R5	RP34R4	RP34R3	RP34R2	RP34R1	RP34R0
bit 7							bit 0

Legend:

R = Readable bit W = Writable bit U = Unimplemented bit, read as '0'
 -n = Value at POR '1' = Bit is set '0' = Bit is cleared x = Bit is unknown

- bit 15-14 **Unimplemented:** Read as '0'
- bit 13-8 **RP35R<5:0>:** Peripheral Output Function is Assigned to RP35 Output Pin bits
 (see [Table 10-2](#) for peripheral function numbers)
- bit 7-6 **Unimplemented:** Read as '0'
- bit 5-0 **RP34R<5:0>:** Peripheral Output Function is Assigned to RP34 Output Pin bits
 (see [Table 10-2](#) for peripheral function numbers)

dsPIC33FJ06GS101/X02 and dsPIC33FJ16GSX02/X04

11.0 TIMER1

Note 1: This data sheet summarizes the features of the dsPIC33FJ06GS101/X02 and dsPIC33FJ16GSX02/X04 families of devices. It is not intended to be a comprehensive reference source. To complement the information in this data sheet, refer to “Timers” (DS70205) in the “dsPIC33F/PIC24H Family Reference Manual”, which is available from the Microchip web site (www.microchip.com).

2: Some registers and associated bits described in this section may not be available on all devices. Refer to [Section 4.0 “Memory Organization”](#) in this data sheet for device-specific register and bit information.

The Timer1 module is a 16-bit timer, which can serve as a time counter for the Real-Time Clock (RTC), or operate as a free-running interval timer/counter.

The Timer1 module has the following unique features over other timers:

- Can be operated from the low-power 32 kHz crystal oscillator available on the device
- Can be operated in Asynchronous Counter mode from an external clock source
- Optionally, the external clock input (T1CK) can be synchronized to the internal device clock and the clock synchronization is performed after the prescaler

The unique features of Timer1 allow it to be used for Real-Time Clock (RTC) applications. A block diagram of Timer1 is shown in [Figure 11-1](#).

The Timer1 module can operate in one of the following modes:

- Timer mode
- Gated Timer mode
- Synchronous Counter mode
- Asynchronous Counter mode

In Timer and Gated Timer modes, the input clock is derived from the internal instruction cycle clock (FCY). In Synchronous and Asynchronous Counter modes, the input clock is derived from the external clock input at the T1CK pin.

The Timer modes are determined by the following bits:

- Timer Clock Source Control bit (TCS): T1CON<1>
- Timer Synchronization Control bit (TSYNC): T1CON<2>
- Timer Gate Control bit (TGATE): T1CON<6>

The timer control bit settings for different operating modes are given in the [Table 11-1](#).

TABLE 11-1: TIMER MODE SETTINGS

Mode	TCS	TGATE	TSYNC
Timer	0	0	x
Gated Timer	0	1	x
Synchronous Counter	1	x	1
Asynchronous Counter	1	x	0

FIGURE 11-1: 16-BIT TIMER1 MODULE BLOCK DIAGRAM



dsPIC33FJ06GS101/X02 and dsPIC33FJ16GSX02/X04

REGISTER 11-1: T1CON: TIMER1 CONTROL REGISTER

R/W-0	U-0	R/W-0	U-0	U-0	U-0	U-0	U-0
TON	—	TSIDL	—	—	—	—	—
bit 15							bit 8

U-0	R/W-0	R/W-0	R/W-0	U-0	R/W-0	R/W-0	U-0
—	TGATE	TCKPS1	TCKPS0	—	TSYNC	TCS	—
bit 7							bit 0

Legend:

R = Readable bit W = Writable bit U = Unimplemented bit, read as '0'
 -n = Value at POR '1' = Bit is set '0' = Bit is cleared x = Bit is unknown

- bit 15 **TON:** Timer1 On bit
 1 = Starts 16-bit Timer1
 0 = Stops 16-bit Timer1
- bit 14 **Unimplemented:** Read as '0'
- bit 13 **TSIDL:** Timer1 Stop in Idle Mode bit
 1 = Discontinues module operation when device enters Idle mode
 0 = Continues module operation in Idle mode
- bit 12-7 **Unimplemented:** Read as '0'
- bit 6 **TGATE:** Timer1 Gated Time Accumulation Enable bit
 When TCS = 1:
 This bit is ignored.
 When TCS = 0:
 1 = Gated time accumulation is enabled
 0 = Gated time accumulation is disabled
- bit 5-4 **TCKPS<1:0>** Timer1 Input Clock Prescale Select bits
 11 = 1:256
 10 = 1:64
 01 = 1:8
 00 = 1:1
- bit 3 **Unimplemented:** Read as '0'
- bit 2 **TSYNC:** Timer1 External Clock Input Synchronization Select bit
 When TCS = 1:
 1 = Synchronizes external clock input
 0 = Does not synchronize external clock input
 When TCS = 0:
 This bit is ignored.
- bit 1 **TCS:** Timer1 Clock Source Select bit
 1 = External clock from T1CK pin (on the rising edge)
 0 = Internal clock (FCY)
- bit 0 **Unimplemented:** Read as '0'

dsPIC33FJ06GS101/X02 and dsPIC33FJ16GSX02/X04

12.0 TIMER2/3 FEATURES

Note 1: This data sheet summarizes the features of the dsPIC33FJ06GS101/X02 and dsPIC33FJ16GSX02/X04 families of devices. It is not intended to be a comprehensive reference source. To complement the information in this data sheet, refer to “Timers” (DS70205) in the “dsPIC33F/PIC24H Family Reference Manual”, which is available on the Microchip web site (www.microchip.com).

2: Some registers and associated bits described in this section may not be available on all devices. Refer to **Section 4.0 “Memory Organization”** in this data sheet for device-specific register and bit information.

Timer2 is a Type B timer that offers the following major features:

- A Type B timer can be concatenated with a Type C timer to form a 32-bit timer
- External clock input (TxCK) is always synchronized to the internal device clock and the clock synchronization is performed after the prescaler.

Figure 12-1 shows a block diagram of the Type B timer.

Timer3 is a Type C timer that offers the following major features:

- A Type C timer can be concatenated with a Type B timer to form a 32-bit timer
- The external clock input (TxCK) is always synchronized to the internal device clock and the clock synchronization is performed before the prescaler

A block diagram of the Type C timer is shown in Figure 12-2.

Note: Timer3 is not available on all devices.

FIGURE 12-1: TYPE B TIMER BLOCK DIAGRAM (x = 2)



FIGURE 12-2: TYPE C TIMER BLOCK DIAGRAM (x = 3)



dsPIC33FJ06GS101/X02 and dsPIC33FJ16GSX02/X04

The Timer2/3 module can operate in one of the following modes:

- Timer mode
- Gated Timer mode
- Synchronous Counter mode

In Timer and Gated Timer modes, the input clock is derived from the internal instruction cycle clock (FCY). In Synchronous Counter mode, the input clock is derived from the external clock input at the TxCK pin.

The timer modes are determined by the following bits:

- TCS (TxCON<1>): Timer Clock Source Control bit
- TGATE (TxCON<6>): Timer Gate Control bit

Timer control bit settings for different operating modes are given in the [Table 12-1](#).

TABLE 12-1: TIMER MODE SETTINGS

Mode	TCS	TGATE
Timer	0	0
Gated Timer	0	1
Synchronous Counter	1	x

12.1 16-Bit Operation

To configure any of the timers for individual 16-bit operation:

1. Clear the T32 bit corresponding to that timer.
2. Select the timer prescaler ratio using the TCKPS<1:0> bits.
3. Set the Clock and Gating modes using the TCS and TGATE bits.
4. Load the timer period value into the PRx register.
5. If interrupts are required, set the interrupt enable bit, TxIE. Use the priority bits, TxIP<2:0>, to set the interrupt priority.
6. Set the TON bit.

12.2 32-Bit Operation

A 32-bit timer module can be formed by combining a Type B and a Type C 16-bit timer module. For 32-bit timer operation, the T32 control bit in the Type B Timer Control (TxCON<3>) register must be set. The Type C timer holds the most significant word (msw) and the Type B timer holds the least significant word (lsw) for 32-bit operation.

When configured for 32-bit operation, only the Type B Timer Control (TxCON) register bits are required for setup and control while the Type C Timer Control register bits are ignored (except the TSIDL bit).

For interrupt control, the combined 32-bit timer uses the interrupt enable, interrupt flag and interrupt priority control bits of the Type C timer. The interrupt control and status bits for the Type B timer are ignored during 32-bit timer operation.

The Timer2 and Timer 3 that can be combined to form a 32-bit timer are listed in [Table 12-2](#).

TABLE 12-2: 32-BIT TIMER

Type B Timer (lsw)	Type C Timer (msw)
Timer2	Timer3

A block diagram representation of the 32-bit timer module is shown in [Figure 12-3](#). The 32-timer module can operate in one of the following modes:

- Timer mode
- Gated Timer mode
- Synchronous Counter mode

To configure the features of Timer2/3 for 32-bit operation:

1. Set the T32 control bit.
2. Select the prescaler ratio for Timer2 using the TCKPS<1:0> bits.
3. Set the Clock and Gating modes using the corresponding TCS and TGATE bits.
4. Load the timer period value. PR3 contains the most significant word of the value, while PR2 contains the least significant word.
5. If interrupts are required, set the interrupt enable bit, T3IE. Use the priority bits, T3IP<2:0>, to set the interrupt priority. While Timer2 controls the timer, the interrupt appears as a Timer3 interrupt.
6. Set the corresponding TON bit.

The timer value at any point is stored in the register pair, TMR3:TMR2, which always contains the most significant word of the count, while TMR2 contains the least significant word.

dsPIC33FJ06GS101/X02 and dsPIC33FJ16GSX02/X04

FIGURE 12-3: 32-BIT TIMER BLOCK DIAGRAM



dsPIC33FJ06GS101/X02 and dsPIC33FJ16GSX02/X04

REGISTER 12-1: TxCON: TIMERx CONTROL REGISTER (x = 2)

R/W-0	U-0	R/W-0	U-0	U-0	U-0	U-0	U-0
TON	—	TSIDL	—	—	—	—	—
bit 15						bit 8	

U-0	R/W-0	R/W-0	R/W-0	R/W-0	U-0	R/W-0	U-0
—	TGATE	TCKPS1	TCKPS0	T32	—	TCS	—
bit 7						bit 0	

Legend:

R = Readable bit

W = Writable bit

U = Unimplemented bit, read as '0'

-n = Value at POR

'1' = Bit is set

'0' = Bit is cleared

x = Bit is unknown

bit 15 **TON:** Timerx On bit

When T32 = 1 (in 32-Bit Timer mode):

1 = Starts 32-bit TMRx:TMRy timer pair

0 = Stops 32-bit TMRx:TMRy timer pair

When T32 = 0 (in 16-Bit Timer mode):

1 = Starts 16-bit timer

0 = Stops 16-bit timer

bit 14 **Unimplemented:** Read as '0'

bit 13 **TSIDL:** Timerx Stop in Idle Mode bit

1 = Discontinues timer operation when device enters Idle mode

0 = Continues timer operation in Idle mode

bit 12-7 **Unimplemented:** Read as '0'

bit 6 **TGATE:** Timerx Gated Time Accumulation Enable bit

When TCS = 1:

This bit is ignored.

When TCS = 0:

1 = Gated time accumulation is enabled

0 = Gated time accumulation is disabled

bit 5-4 **TCKPS<1:0>:** Timerx Input Clock Prescale Select bits

11 = 1:256 prescale value

10 = 1:64 prescale value

01 = 1:8 prescale value

00 = 1:1 prescale value

bit 3 **T32:** 32-Bit Timerx Mode Select bit

1 = TMRx and TMRy form a 32-bit timer

0 = TMRx and TMRy form a separate 16-bit timer

bit 2 **Unimplemented:** Read as '0'

bit 1 **TCS:** Timerx Clock Source Select bit

1 = External clock from TxCK pin

0 = Internal clock (Fosc/2)

bit 0 **Unimplemented:** Read as '0'

dsPIC33FJ06GS101/X02 and dsPIC33FJ16GSX02/X04

REGISTER 12-2: TyCON: TIMERY CONTROL REGISTER (y = 3)

R/W-0	U-0	R/W-0	U-0	U-0	U-0	U-0	U-0
TON ⁽²⁾	—	TSIDL ⁽¹⁾	—	—	—	—	—
bit 15							bit 8

U-0	R/W-0	R/W-0	R/W-0	U-0	U-0	R/W-0	U-0
—	TGATE ⁽²⁾	TCKPS1 ⁽²⁾	TCKPS0 ⁽²⁾	—	—	TCS ⁽²⁾	—
bit 7							bit 0

Legend:

R = Readable bit W = Writable bit U = Unimplemented bit, read as '0'
 -n = Value at POR '1' = Bit is set '0' = Bit is cleared x = Bit is unknown

- bit 15 **TON:** Timery On bit⁽²⁾
 1 = Starts 16-bit Timery
 0 = Stops 16-bit Timery
- bit 14 **Unimplemented:** Read as '0'
- bit 13 **TSIDL:** Timery Stop in Idle Mode bit⁽¹⁾
 1 = Discontinues timer operation when device enters Idle mode
 0 = Continues timer operation in Idle mode
- bit 12-7 **Unimplemented:** Read as '0'
- bit 6 **TGATE:** Timery Gated Time Accumulation Enable bit⁽²⁾
 When TCS = 1:
 This bit is ignored.
 When TCS = 0:
 1 = Gated time accumulation is enabled
 0 = Gated time accumulation is disabled
- bit 5-4 **TCKPS<1:0>:** Timery Input Clock Prescale Select bits⁽²⁾
 11 = 1:256 prescale value
 10 = 1:64 prescale value
 01 = 1:8 prescale value
 00 = 1:1 prescale value
- bit 3-2 **Unimplemented:** Read as '0'
- bit 1 **TCS:** Timery Clock Source Select bit⁽²⁾
 1 = External clock from TxCK pin
 0 = Internal clock (FOSC/2)
- bit 0 **Unimplemented:** Read as '0'

- Note 1:** When 32-bit timer operation is enabled (T32 = 1) in the Timerx Control register (TxCON<3>), the TSIDL bit must be cleared to operate the 32-bit timer in Idle mode.
- 2:** When the 32-bit timer operation is enabled (T32 = 1) in the Timerx Control (TxCON<3>) register, these bits have no effect.

dsPIC33FJ06GS101/X02 and dsPIC33FJ16GSX02/X04

NOTES:

dsPIC33FJ06GS101/X02 and dsPIC33FJ16GSX02/X04

13.0 INPUT CAPTURE

Note 1: This data sheet summarizes the features of the dsPIC33FJ06GS101/X02 and dsPIC33FJ16GSX02/X04 families of devices. It is not intended to be a comprehensive reference source. To complement the information in this data sheet, refer to “**Input Capture**” (DS70198) in the “*dsPIC33F/PIC24H Family Reference Manual*”, which is available on the Microchip web site (www.microchip.com).

2: Some registers and associated bits described in this section may not be available on all devices. Refer to **Section 4.0 “Memory Organization”** in this data sheet for device-specific register and bit information.

The input capture module is useful in applications requiring frequency (period) and pulse measurement. dsPIC33FJ06GS101/X02 and dsPIC33FJ16GSX02/X04 devices support up to two input capture channels.

The input capture module captures the 16-bit value of the selected Time Base register when an event occurs at the ICx pin. The events that cause a capture event are listed below in three categories:

- Simple Capture Event modes:
 - Capture timer value on every falling edge of input at ICx pin
 - Capture timer value on every rising edge of input at ICx pin
- Capture timer value on every edge (rising and falling)
- Prescaler Capture Event modes:
 - Capture timer value on every 4th rising edge of input at ICx pin
 - Capture timer value on every 16th rising edge of input at ICx pin

Each input capture channel can select one of the two 16-bit timers (Timer2 or Timer3) for the time base. The selected timer can use either an internal or external clock.

Other operational features include:

- Device wake-up from capture pin during CPU Sleep and Idle modes
- Interrupt on input capture event
- 4-word FIFO buffer for capture values
 - Interrupt optionally generated after 1, 2, 3 or 4 buffer locations are filled
- Use of input capture to provide additional sources of external interrupts

FIGURE 13-1: INPUT CAPTURE x BLOCK DIAGRAM

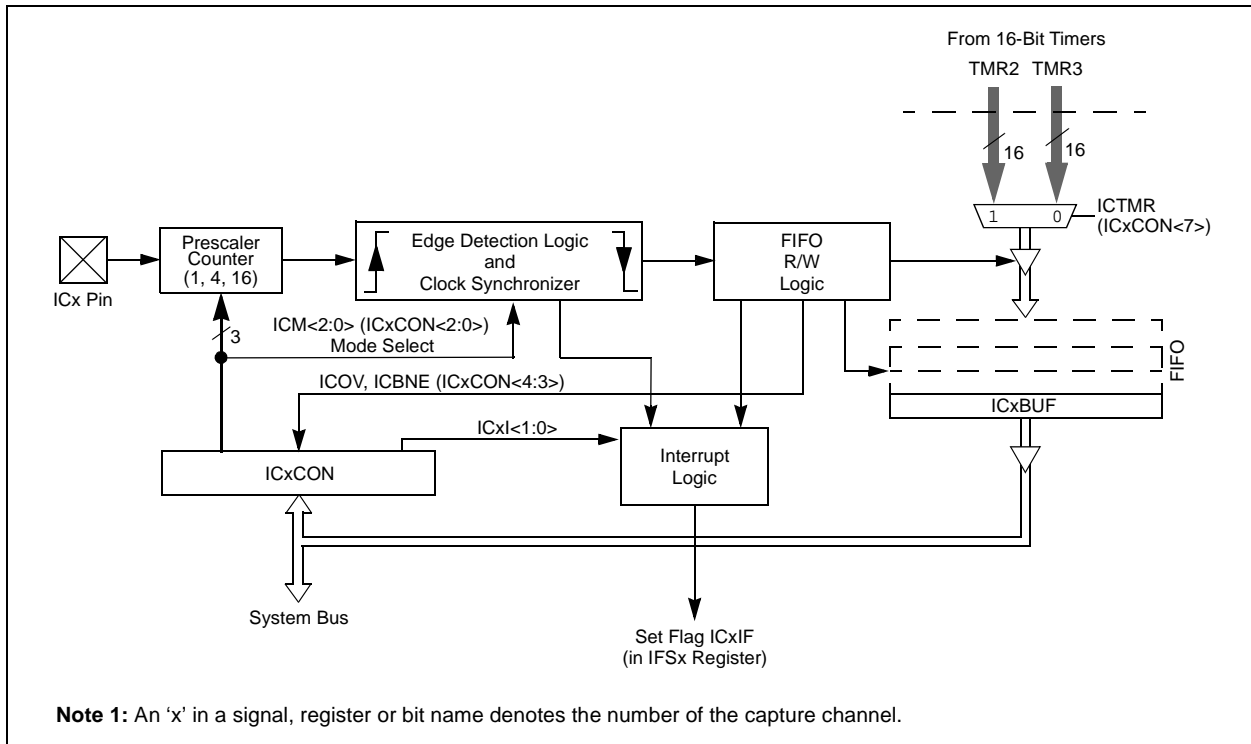

dsPIC33FJ06GS101/X02 and dsPIC33FJ16GSX02/X04

13.1 Input Capture Register

REGISTER 13-1: ICxCON: INPUT CAPTURE x CONTROL REGISTER (x = 1, 2)

U-0	U-0	R/W-0	U-0	U-0	U-0	U-0	U-0
—	—	ICSIDL	—	—	—	—	—
bit 15							bit 8

R/W-0	R/W-0	R/W-0	R-0, HC	R-0, HC	R/W-0	R/W-0	R/W-0
ICTMR	ICI1	ICI0	ICOV	ICBNE	ICM2	ICM1	ICM0
bit 7							bit 0

Legend:	HC = Hardware Clearable bit
R = Readable bit	W = Writable bit
-n = Value at POR	'1' = Bit is set
	U = Unimplemented bit, read as '0'
	'0' = Bit is cleared
	x = Bit is unknown

- bit 15-14 **Unimplemented:** Read as '0'
- bit 13 **ICSIDL:** Input Capture Module Stop in Idle Control bit
 - 1 = Input capture module halts in CPU Idle mode
 - 0 = Input capture module continues to operate in CPU Idle mode
- bit 12-8 **Unimplemented:** Read as '0'
- bit 7 **ICTMR:** Input Capture Timer Select bits
 - 1 = TMR2 contents are captured on a capture event
 - 0 = TMR3 contents are captured on a capture event
- bit 6-5 **ICI<1:0>:** Select Number of Captures per Interrupt bits
 - 11 = Interrupt on every fourth capture event
 - 10 = Interrupt on every third capture event
 - 01 = Interrupt on every second capture event
 - 00 = Interrupt on every capture event
- bit 4 **ICOV:** Input Capture Overflow Status Flag bit (read-only)
 - 1 = Input capture overflow occurred
 - 0 = No input capture overflow occurred
- bit 3 **ICBNE:** Input Capture Buffer Empty Status bit (read-only)
 - 1 = Input capture buffer is not empty, at least one more capture value can be read
 - 0 = Input capture buffer is empty
- bit 2-0 **ICM<2:0>:** Input Capture Mode Select bits
 - 111 = Input capture functions as interrupt pin only when device is in Sleep or Idle mode; rising edge detect only, all other control bits are not applicable
 - 110 = Unused (module disabled)
 - 101 = Capture mode, every 16th rising edge
 - 100 = Capture mode, every 4th rising edge
 - 011 = Capture mode, every rising edge
 - 010 = Capture mode, every falling edge
 - 001 = Capture mode, every edge (rising and falling); ICI<1:0> bits do not control interrupt generation for this mode
 - 000 = Input capture module turned off

dsPIC33FJ06GS101/X02 and dsPIC33FJ16GSX02/X04

14.0 OUTPUT COMPARE

Note 1: This data sheet summarizes the features of the dsPIC33FJ06GS101/X02 and dsPIC33FJ16GSX02/X04 families of devices. It is not intended to be a comprehensive reference source. To complement the information in this data sheet, refer to “**Output Compare**” (DS70005157) in the “*dsPIC33F/PIC24H Family Reference Manual*”, which is available on the Microchip web site (www.microchip.com).

2: Some registers and associated bits described in this section may not be available on all devices. Refer to [Section 4.0 “Memory Organization”](#) in this data sheet for device-specific register and bit information.

The output compare module can select either Timer2 or Timer3 for its time base. The module compares the value of the timer with the value of one or two Compare registers depending on the operating mode selected. The state of the output pin changes when the timer value matches the Compare register value. The output compare module generates either a single output pulse, or a sequence of output pulses, by changing the state of the output pin on the compare match events. The output compare module can also generate interrupts on compare match events.

The output compare module has multiple operating modes:

- Active-Low One-Shot mode
- Active-High One-Shot mode
- Toggle mode
- Delayed One-Shot mode
- Continuous Pulse mode
- PWM mode without Fault Protection
- PWM mode with Fault Protection

FIGURE 14-1: OUTPUT COMPARE x MODULE BLOCK DIAGRAM



dsPIC33FJ06GS101/X02 and dsPIC33FJ16GSX02/X04

14.1 Output Compare Modes

Configure the Output Compare modes by setting the appropriate Output Compare Mode (OCM<2:0>) bits in the Output Compare Control (OCxCON<2:0>) register. Table 14-1 lists the different bit settings for the Output Compare modes. Figure 14-2 illustrates the output compare operation for various modes. The user

application must disable the associated timer when writing to the Output Compare Control registers to avoid malfunctions.

Note: Refer to “Output Compare” (DS70209) in the “dsPIC33F/PIC24H Family Reference Manual” for OCxR and OCxRS register restrictions.

TABLE 14-1: OUTPUT COMPARE MODES

OCM<2:0>	Mode	OCx Pin Initial State	OCx Interrupt Generation
111	PWM with Fault Protection	'0', if OCxR is zero '1', if OCxR is non-zero	OCFA falling edge for OC1 to OC4
110	PWM without Fault Protection	'0', if OCxR is zero '1', if OCxR is non-zero	No interrupt
101	Continuous Pulse	0	OCx falling edge
100	Delayed One-Shot	0	OCx falling edge
011	Toggle	Current output is maintained	OCx rising and falling edge
010	Active-High One-Shot	1	OCx falling edge
001	Active-Low One-Shot	0	OCx rising edge
000	Module Disabled	Controlled by GPIO register	—

FIGURE 14-2: OUTPUT COMPARE OPERATION



dsPIC33FJ06GS101/X02 and dsPIC33FJ16GSX02/X04

REGISTER 14-1: OCxCON: OUTPUT COMPARE x CONTROL REGISTER (x = 1, 2)

U-0	U-0	R/W-0	U-0	U-0	U-0	U-0	U-0
—	—	OCSIDL	—	—	—	—	—
bit 15							bit 8

U-0	U-0	U-0	R-0, HC	R/W-0	R/W-0	R/W-0	R/W-0
—	—	—	OCFLT	OCTSEL	OCM2	OCM1	OCM0
bit 7							bit 0

Legend:	HC = Hardware Clearable bit
R = Readable bit	W = Writable bit
-n = Value at POR	'1' = Bit is set
	U = Unimplemented bit, read as '0'
	'0' = Bit is cleared
	x = Bit is unknown

- bit 15-14 **Unimplemented:** Read as '0'
- bit 13 **OCSIDL:** Stop Output Compare in Idle Mode Control bit
 - 1 = Output Compare x halts in CPU Idle mode
 - 0 = Output Compare x continues to operate in CPU Idle mode
- bit 12-5 **Unimplemented:** Read as '0'
- bit 4 **OCFLT:** PWM Fault Condition Status bit
 - 1 = PWM Fault condition has occurred (cleared in hardware only)
 - 0 = No PWM Fault condition has occurred (this bit is only used when OCM<2:0> = 111)
- bit 3 **OCTSEL:** Output Compare Timer Select bit
 - 1 = Timer3 is the clock source for Output Compare x
 - 0 = Timer2 is the clock source for Output Compare x
- bit 2-0 **OCM<2:0>:** Output Compare Mode Select bits
 - 111 = PWM mode on OCx, Fault pin is enabled
 - 110 = PWM mode on OCx, Fault pin is disabled
 - 101 = Initializes OCx pin low, generates continuous output pulses on OCx pin
 - 100 = Initializes OCx pin low, generates single output pulse on OCx pin
 - 011 = Compare event toggles OCx pin
 - 010 = Initializes OCx pin high, compare event forces OCx pin low
 - 001 = Initializes OCx pin low, compare event forces OCx pin high
 - 000 = Output compare channel is disabled

dsPIC33FJ06GS101/X02 and dsPIC33FJ16GSX02/X04

NOTES:

15.0 HIGH-SPEED PWM

Note 1: This data sheet summarizes the features of the dsPIC33FJ06GS101/X02 and dsPIC33FJ16GSX02/X04 families of devices. It is not intended to be a comprehensive reference source. To complement the information in this data sheet, refer to “**High-Speed PWM**” (DS70323) in the “*dsPIC33F/PIC24H Family Reference Manual*”, which is available on the Microchip web site (www.microchip.com).

2: Some registers and associated bits described in this section may not be available on all devices. Refer to **Section 4.0 “Memory Organization”** in this data sheet for device-specific register and bit information.

The high-speed PWM module on the dsPIC33FJ06GS101/X02 and dsPIC33FJ16GSX02/X04 devices supports a wide variety of PWM modes and output formats. This PWM module is ideal for power conversion applications, such as:

- AC/DC Converters
- DC/DC Converters
- Power Factor Correction (PFC)
- Uninterruptible Power Supply (UPS)
- Inverters
- Battery Chargers
- Digital Lighting

15.1 Features Overview

The high-speed PWM module incorporates the following features:

- 2-4 PWM generators with 4-8 outputs
- Individual time base and duty cycle for each of the eight PWM outputs
- Dead time for rising and falling edges:
- Duty cycle resolution of 1.04 ns
- Dead-time resolution of 1.04 ns
- Phase-shift resolution of 1.04 ns
- Frequency resolution of 1.04 ns
- PWM modes supported:
 - Standard Edge-Aligned
 - True Independent Output
 - Complementary
 - Center-Aligned
 - Push-Pull
 - Multiphase
 - Variable Phase
 - Fixed Off-Time
 - Current Reset
 - Current-Limit

- Independent Fault/Current-Limit inputs for each of the eight PWM outputs
- Output override control
- Special Event Trigger
- PWM capture feature
- Prescaler for input clock
- Dual trigger from PWM to ADC
- PWMxH, PWMxL output pin swapping
- PWM4H, PWM4L pins remappable
- On-the-fly PWM frequency, duty cycle and phase-shift changes
- Disabling of Individual PWM generators to reduce power consumption
- Leading-Edge Blanking (LEB) functionality

Note: Duty cycle, dead time, phase shift and frequency resolution is 8.32 ns in Center-Aligned PWM mode.

Figure 15-1 conceptualizes the PWM module in a simplified block diagram. Figure 15-2 illustrates how the module hardware is partitioned for each PWM output pair for the Complementary PWM mode. Each functional unit of the PWM module is discussed in subsequent sections.

The PWM module contains four PWM generators. The module has up to eight PWM output pins: PWM1H, PWM1L, PWM2H, PWM2L, PWM3H, PWM3L, PWM4H and PWM4L. For complementary outputs, these eight I/O pins are grouped into H/L pairs.

dsPIC33FJ06GS101/X02 and dsPIC33FJ16GSX02/X04

15.2 Feature Description

The PWM module is designed for applications that require:

- High-resolution at high PWM frequencies
- The ability to drive Standard, Edge-Aligned, Center-Aligned Complementary mode, and Push-Pull mode outputs
- The ability to create multiphase PWM outputs

For Center-Aligned mode, the duty cycle, period phase and dead-time resolutions will be 8.32 ns.

Two common, medium power converter topologies are push-pull and half-bridge. These designs require the PWM output signal to be switched between alternate pins, as provided by the Push-Pull PWM mode.

Phase-shifted PWM describes the situation where each PWM generator provides outputs, but the phase relationship between the generator outputs is specifiable and changeable.

Multiphase PWM is often used to improve DC/DC Converter load transient response, and reduce the size of output filter capacitors and inductors. Multiple DC/DC Converters are often operated in parallel, but phase-shifted in time. A single PWM output operating at 250 kHz has a period of 4 μ s, but an array of four PWM channels, staggered by 1 μ s each, yields an effective switching frequency of 1 MHz. Multiphase PWM applications typically use a fixed-phase relationship.

Variable phase PWM is useful in Zero Voltage Transition (ZVT) power converters. Here, the PWM duty cycle is always 50%, and the power flow is controlled by varying the relative phase shift between the two PWM generators.

dsPIC33FJ06GS101/X02 and dsPIC33FJ16GSX02/X04

FIGURE 15-1: SIMPLIFIED CONCEPTUAL BLOCK DIAGRAM OF HIGH-SPEED PWM



dsPIC33FJ06GS101/X02 and dsPIC33FJ16GSX02/X04

FIGURE 15-2: PARTITIONED OUTPUT PAIR, COMPLEMENTARY PWM MODE



15.3 Control Registers

The following registers control the operation of the high-speed PWM module.

- [PTCON: PWM Time Base Control Register](#)
- [PTCON2: PWM Clock Divider Select Register](#)
- [PTPER: PWM Master Time Base Register\(1\)](#)
- [SEVTCMP: PWM Special Event Compare Register](#)
- [MDC: PWM Master Duty Cycle Register\(1,2\)](#)
- [PWMCONx: PWMx Control Register](#)
- [PDCx: PWMx Generator Duty Cycle Register\(1,2\)](#)
- [PHASEx: PWMx Primary Phase-Shift Register\(1,2\)](#) (provides the local time base period for PWMxH)
- [DTRx: PWMx Dead-Time Register](#)
- [ALTDTRx: PWMx Alternate Dead-Time Register](#)
- [SDCx: PWMx Secondary Duty Cycle Register\(1,2\)](#)
- [SPHASEx: PWMx Secondary Phase-Shift Register\(1,2\)](#) (provides the local time base period for PWMxL)
- [TRGCONx: PWMx Trigger Control Register](#)
- [IOCONx: PWMx I/O Control Register](#)
- [FCLCONx: PWMx Fault Current-Limit Control Register](#)
- [TRIGx: PWMx Primary Trigger Compare Value Register](#)
- [STRIGx: PWMx Secondary Trigger Compare Value Register](#)
- [LEBCONx: Leading-Edge Blanking Control Register\(1\)](#)
- [PWMCAPx: Primary PWMx Time Base Capture Register](#)

dsPIC33FJ06GS101/X02 and dsPIC33FJ16GSX02/X04

REGISTER 15-1: PTCON: PWM TIME BASE CONTROL REGISTER

R/W-0	U-0	R/W-0	HS/HC-0	R/W-0	R/W-0	R/W-0	R/W-0
PTEN	—	PTSIDL	SESTAT	SEIEN	EIPU ⁽¹⁾	SYNCPOL ⁽¹⁾	SYNCOEN ⁽¹⁾
bit 15						bit 8	

R/W-0	U-0	R/W-0	R/W-0	R/W-0	R/W-0	R/W-0	R/W-0
SYNCEN ⁽¹⁾	—	SYNCSRC1 ⁽¹⁾	SYNCSRC0 ⁽¹⁾	SEVTPS3 ⁽¹⁾	SEVTPS2 ⁽¹⁾	SEVTPS1 ⁽¹⁾	SEVTPS0 ⁽¹⁾
bit 7						bit 0	

Legend:	HC = Hardware Clearable bit	HS = Hardware Settable bit
R = Readable bit	W = Writable bit	U = Unimplemented bit, read as '0'
-n = Value at POR	'1' = Bit is set	'0' = Bit is cleared
		x = Bit is unknown

- bit 15 **PTEN:** PWM Module Enable bit
1 = PWM module is enabled
0 = PWM module is disabled
- bit 14 **Unimplemented:** Read as '0'
- bit 13 **PTSIDL:** PWM Time Base Stop in Idle Mode bit
1 = PWM time base halts in CPU Idle mode
0 = PWM time base runs in CPU Idle mode
- bit 12 **SESTAT:** Special Event Interrupt Status bit
1 = Special event interrupt is pending
0 = Special event interrupt is not pending
- bit 11 **SEIEN:** Special Event Interrupt Enable bit
1 = Special event interrupt is enabled
0 = Special event interrupt is disabled
- bit 10 **EIPU:** Enable Immediate Period Updates bit⁽¹⁾
1 = Active Period register is updated immediately
0 = Active Period register updates occur on PWM cycle boundaries
- bit 9 **SYNCPOL:** Synchronization Input/Output Polarity bit⁽¹⁾
1 = SYNCIx and SYNCO polarity is inverted (active-low)
0 = SYNCIx and SYNCO are active-high
- bit 8 **SYNCOEN:** Primary Time Base Sync Enable bit⁽¹⁾
1 = SYNCO output is enabled
0 = SYNCO output is disabled
- bit 7 **SYNCEN:** External Time Base Synchronization Enable bit⁽¹⁾
1 = External synchronization of primary time base is enabled
0 = External synchronization of primary time base is disabled
- bit 6 **Unimplemented:** Read as '0'
- bit 5-4 **SYNCSRC<1:0>:** Synchronous Source Selection bits⁽¹⁾
11 = Reserved
10 = Reserved
01 = SYNCI2
00 = SYNCI1

Note 1: These bits should be changed only when PTEN = 0. In addition, when using the SYNCIx feature, the user application must program the Period register with a value that is slightly larger than the expected period of the external synchronization input signal.

dsPIC33FJ06GS101/X02 and dsPIC33FJ16GSX02/X04

REGISTER 15-1: PTCON: PWM TIME BASE CONTROL REGISTER (CONTINUED)

bit 3-0 **SEVTPS<3:0>**: PWM Special Event Trigger Output Postscaler Select bits⁽¹⁾

- 1111 = 1:16 Postscaler generates a Special Event Trigger trigger on every sixteenth compare match event
-
-
- 0001 = 1:2 Postscaler generates a Special Event Trigger on every second compare match event
- 0000 = 1:1 Postscaler generates a Special Event Trigger on every compare match event

Note 1: These bits should be changed only when PTEN = 0. In addition, when using the SYNCIx feature, the user application must program the Period register with a value that is slightly larger than the expected period of the external synchronization input signal.

dsPIC33FJ06GS101/X02 and dsPIC33FJ16GSX02/X04

REGISTER 15-2: PTCON2: PWM CLOCK DIVIDER SELECT REGISTER

U-0	U-0	U-0	U-0	U-0	U-0	U-0	U-0
—	—	—	—	—	—	—	—
bit 15							bit 8

U-0	U-0	U-0	U-0	U-0	R/W-0	R/W-0	R/W-0
—	—	—	—	—	PCLKDIV<2:0> ⁽¹⁾		
bit 7						bit 0	

Legend:

R = Readable bit W = Writable bit U = Unimplemented bit, read as '0'
 -n = Value at POR '1' = Bit is set '0' = Bit is cleared x = Bit is unknown

bit 15-3 **Unimplemented:** Read as '0'

bit 2-0 **PCLKDIV<2:0>:** PWM Input Clock Prescaler (Divider) Select bits⁽¹⁾

- 111 = Reserved
- 110 = Divide-by-64, maximum PWM timing resolution
- 101 = Divide-by-32, maximum PWM timing resolution
- 100 = Divide-by-16, maximum PWM timing resolution
- 011 = Divide-by-8, maximum PWM timing resolution
- 010 = Divide-by-4, maximum PWM timing resolution
- 001 = Divide-by-2, maximum PWM timing resolution
- 000 = Divide-by-1, maximum PWM timing resolution (power-on default)

Note 1: These bits should be changed only when PTEN = 0. Changing the clock selection during operation will yield unpredictable results.

REGISTER 15-3: PTPER: PWM MASTER TIME BASE REGISTER⁽¹⁾

R/W-1	R/W-1	R/W-1	R/W-1	R/W-1	R/W-1	R/W-1	R/W-1
PTPER <15:8>							
bit 15							bit 8

R/W-1	R/W-1	R/W-1	R/W-1	R/W-1	R/W-0	R/W-0	R/W-0
PTPER <7:0>							
bit 7						bit 0	

Legend:

R = Readable bit W = Writable bit U = Unimplemented bit, read as '0'
 -n = Value at POR '1' = Bit is set '0' = Bit is cleared x = Bit is unknown

bit 15-0 **PTPER<15:0>:** PWM Master Time Base (PMTMR) Period Value bits

Note 1: The minimum value that can be loaded into the PTPER register is 0x0010 and the maximum value is 0xFFFF8.

dsPIC33FJ06GS101/X02 and dsPIC33FJ16GSX02/X04

REGISTER 15-4: SEVTCMP: PWM SPECIAL EVENT COMPARE REGISTER

R/W-0	R/W-0	R/W-0	R/W-0	R/W-0	R/W-0	R/W-0	R/W-0
SEVTCMP <15:8>							
bit 15				bit 8			

R/W-0	R/W-0	R/W-0	R/W-0	R/W-0	U-0	U-0	U-0
SEVTCMP <7:3>					—	—	—
bit 7			bit 0				

Legend:

R = Readable bit W = Writable bit U = Unimplemented bit, read as '0'
 -n = Value at POR '1' = Bit is set '0' = Bit is cleared x = Bit is unknown

bit 15-3 **SEVTCMP<12:0>**: Special Event Compare Count Value bits

bit 2-0 **Unimplemented**: Read as '0'

REGISTER 15-5: MDC: PWM MASTER DUTY CYCLE REGISTER^(1,2)

R/W-0	R/W-0	R/W-0	R/W-0	R/W-0	R/W-0	R/W-0	R/W-0
MDC<15:8>							
bit 15				bit 8			

R/W-0	R/W-0	R/W-0	R/W-0	R/W-0	R/W-0	R/W-0	R/W-0
MDC<7:0>							
bit 7			bit 0				

Legend:

R = Readable bit W = Writable bit U = Unimplemented bit, read as '0'
 -n = Value at POR '1' = Bit is set '0' = Bit is cleared x = Bit is unknown

bit 15-0 **MDC<15:0>**: Master PWM Duty Cycle Value bits

- Note 1:** The smallest pulse width that can be generated on the PWM output corresponds to a value of 0x0009, while the maximum pulse width generated corresponds to a value of Period – 0x0008.
- 2:** As the duty cycle gets closer to 0% or 100% of the PWM period (0 ns-40 ns, depending on the mode of operation), the PWM duty cycle resolution will degrade from 1 LSB to 3 LSBs.

dsPIC33FJ06GS101/X02 and dsPIC33FJ16GSX02/X04

REGISTER 15-6: PWMCONx: PWMx CONTROL REGISTER

HS/HC-0	HS/HC-0	HS/HC-0	R/W-0	R/W-0	R/W-0	R/W-0	R/W-0
FLTSTAT ⁽¹⁾	CLSTAT ⁽¹⁾	TRGSTAT	FLTIEEN	CLIEEN	TRGIEEN	ITB ⁽³⁾	MDCS ⁽³⁾
bit 15						bit 8	

R/W-0	R/W-0	U-0	U-0	U-0	R/W-0	R/W-0	R/W-0
DTC1	DTC0	—	—	—	CAM ^(2,3)	XPRES ⁽⁴⁾	IUE
bit 7						bit 0	

Legend:	HC = Hardware Clearable bit	HS = Hardware Settable bit
R = Readable bit	W = Writable bit	U = Unimplemented bit, read as '0'
-n = Value at POR	'1' = Bit is set	'0' = Bit is cleared
		x = Bit is unknown

- bit 15 **FLTSTAT:** Fault Interrupt Status bit⁽¹⁾
 1 = Fault interrupt is pending
 0 = No Fault interrupt is pending; this bit is cleared by setting FLTIEEN = 0
- bit 14 **CLSTAT:** Current-Limit Interrupt Status bit⁽¹⁾
 1 = Current-limit interrupt is pending
 0 = No current-limit interrupt is pending; this bit is cleared by setting CLIEEN = 0
- bit 13 **TRGSTAT:** Trigger Interrupt Status bit
 1 = Trigger interrupt is pending
 0 = No trigger interrupt is pending; this bit is cleared by setting TRGIEEN = 0
- bit 12 **FLTIEEN:** Fault Interrupt Enable bit
 1 = Fault interrupt is enabled
 0 = Fault interrupt is disabled and the FLTSTAT bit is cleared
- bit 11 **CLIEEN:** Current-Limit Interrupt Enable bit
 1 = Current-limit interrupt is enabled
 0 = Current-limit interrupt is disabled and the CLSTAT bit is cleared
- bit 10 **TRGIEEN:** Trigger Interrupt Enable bit
 1 = A trigger event generates an interrupt request
 0 = Trigger event interrupts are disabled and the TRGSTAT bit is cleared
- bit 9 **ITB:** Independent Time Base Mode bit⁽³⁾
 1 = PHASEx/SPHASEx register provides time base period for this PWM generator
 0 = PTPER register provides timing for this PWM generator
- bit 8 **MDCS:** Master Duty Cycle Register Select bit⁽³⁾
 1 = MDC register provides duty cycle information for this PWM generator
 0 = PDCx/SDCx register provides duty cycle information for this PWM generator
- bit 7-6 **DTC<1:0>:** Dead-Time Control bits
 11 = Reserved
 10 = Dead-time function is disabled
 01 = Negative dead time is actively applied for all output modes
 00 = Positive dead time is actively applied for all output modes
- bit 5-3 **Unimplemented:** Read as '0'

- Note 1:** Software must clear the interrupt status here and the corresponding IFSx bit in the interrupt controller.
- Note 2:** The Independent Time Base mode (ITB = 1) must be enabled to use Center-Aligned mode. If ITB = 0, the CAM bit is ignored.
- Note 3:** These bits should be changed only when PTEN = 0. Changing the clock selection during operation will yield unpredictable results.
- Note 4:** To operate in External Period Reset mode, configure FCLCONx<CLMOD> = 0 and PWMCONx<ITB> = 1.

dsPIC33FJ06GS101/X02 and dsPIC33FJ16GSX02/X04

REGISTER 15-6: PWMCONx: PWMx CONTROL REGISTER (CONTINUED)

- bit 2 **CAM:** Center-Aligned Mode Enable bit^(2,3)
 1 = Center-Aligned mode is enabled
 0 = Center-Aligned mode is disabled
- bit 1 **XPRES:** External PWM Reset Control bit⁽⁴⁾
 1 = Current-limit source resets the time base for this PWM generator if it is in Independent Time Base (ITB) mode
 0 = External pins do not affect PWM time base
- bit 0 **IUE:** Immediate Update Enable bit
 1 = Updates to the active MDC/PDCx/SDCx registers are immediate
 0 = Updates to the active MDC/PDCx/SDCx registers are synchronized to the PWM time base

- Note 1:** Software must clear the interrupt status here and the corresponding IFSx bit in the interrupt controller.
- 2:** The Independent Time Base mode (ITB = 1) must be enabled to use Center-Aligned mode. If ITB = 0, the CAM bit is ignored.
- 3:** These bits should be changed only when PTEN = 0. Changing the clock selection during operation will yield unpredictable results.
- 4:** To operate in External Period Reset mode, configure FCLCONx<CLMOD> = 0 and PWMCONx<ITB> = 1.

dsPIC33FJ06GS101/X02 and dsPIC33FJ16GSX02/X04

REGISTER 15-7: PDCx: PWMx GENERATOR DUTY CYCLE REGISTER^(1,2)

R/W-0	R/W-0	R/W-0	R/W-0	R/W-0	R/W-0	R/W-0	R/W-0
PDCx<15:8>							
bit 15							bit 8

R/W-0	R/W-0	R/W-0	R/W-0	R/W-0	R/W-0	R/W-0	R/W-0
PDCx<7:0>							
bit 7							bit 0

Legend:

R = Readable bit	W = Writable bit	U = Unimplemented bit, read as '0'
-n = Value at POR	'1' = Bit is set	'0' = Bit is cleared x = Bit is unknown

bit 15-0 **PDCx<15:0>**: PWM Generator # Duty Cycle Value bits

- Note 1:** In Independent PWM mode, the PDCx register controls the PWMxH duty cycle only. In Complementary, Redundant and Push-Pull PWM modes, the PDCx register controls the duty cycle of both the PWMxH and PWMxL. The smallest pulse width that can be generated on the PWM output corresponds to a value of 0x0009, while the maximum pulse width generated corresponds to a value of Period-0x0008.
- 2:** As the duty cycle gets closer to 0% or 100% of the PWM period (0 ns-40 ns, depending on the mode of operation), the PWM duty cycle resolution will degrade from 1 LSB to 3 LSBs.

REGISTER 15-8: SDCx: PWMx SECONDARY DUTY CYCLE REGISTER^(1,2)

R/W-0	R/W-0	R/W-0	R/W-0	R/W-0	R/W-0	R/W-0	R/W-0
SDCx<15:8>							
bit 15							bit 8

R/W-0	R/W-0	R/W-0	R/W-0	R/W-0	R/W-0	R/W-0	R/W-0
SDCx<7:0>							
bit 7							bit 0

Legend:

R = Readable bit	W = Writable bit	U = Unimplemented bit, read as '0'
-n = Value at POR	'1' = Bit is set	'0' = Bit is cleared x = Bit is unknown

bit 15-0 **SDCx<15:0>**: Secondary Duty Cycle for PWMxL Output Pin bits

- Note 1:** The SDCx register is used in Independent PWM mode only. When used in Independent PWM mode, the SDCx register controls the PWMxL duty cycle. The smallest pulse width that can be generated on the PWM output corresponds to a value of 0x0009, while the maximum pulse width generated corresponds to a value of Period-0x0008.
- 2:** As the duty cycle gets closer to 0% or 100% of the PWM period (0 ns-40 ns, depending on the mode of operation), the PWM duty cycle resolution will degrade from 1 LSB to 3 LSBs.

dsPIC33FJ06GS101/X02 and dsPIC33FJ16GSX02/X04

REGISTER 15-9: PHASE_x: PWM_x PRIMARY PHASE-SHIFT REGISTER^(1,2)

R/W-0	R/W-0	R/W-0	R/W-0	R/W-0	R/W-0	R/W-0	R/W-0
PHASE _x <15:8>							
bit 15							bit 8

R/W-0	R/W-0	R/W-0	R/W-0	R/W-0	R/W-0	R/W-0	R/W-0
PHASE _x <7:0>							
bit 7							bit 0

Legend:

R = Readable bit	W = Writable bit	U = Unimplemented bit, read as '0'
-n = Value at POR	'1' = Bit is set	'0' = Bit is cleared
		x = Bit is unknown

bit 15-0 **PHASE_x<15:0>**: PWM Phase-Shift Value or Independent Time Base Period for this PWM Generator bits

Note 1: If PWMCON_x<ITB> = 0, the following applies based on the mode of operation:

- Complementary, Redundant and Push-Pull Output mode (PMOD<1:0> (IOCON_x<11:10>) = 00, 01 or 10); PHASE_x<15:0> = Phase-shift value for PWM_xH and PWM_xL outputs
- True Independent Output mode (PMOD<1:0> (IOCON_x<11:10>) = 11); PHASE_x<15:0> = Phase-shift value for PWM_xL only

2: If PWMCON_x<ITB> = 1, the following applies based on the mode of operation:

- Complementary, Redundant, and Push-Pull Output mode (PMOD<1:0> (IOCON_x<11:10>) = 00, 01 or 10); PHASE_x<15:0> = Independent Time Base period value for PWM_xH and PWM_xL
- True Independent Output mode (PMOD<1:0> (IOCON_x<11:10>) = 11); PHASE_x<15:0> = Independent Time Base period value for PWM_xL only
- The smallest pulse width that can be generated on the PWM output corresponds to a value of 0x0008, while the maximum pulse width generated corresponds to a value of Period – 0x0008.

dsPIC33FJ06GS101/X02 and dsPIC33FJ16GSX02/X04

REGISTER 15-10: SPHASE_x: PWM_x SECONDARY PHASE-SHIFT REGISTER^(1,2)

R/W-0	R/W-0	R/W-0	R/W-0	R/W-0	R/W-0	R/W-0	R/W-0
SPHASE _x <15:8>							
bit 15							bit 8

R/W-0	R/W-0	R/W-0	R/W-0	R/W-0	R/W-0	R/W-0	R/W-0
SPHASE _x <7:0>							
bit 7							bit 0

Legend:

R = Readable bit	W = Writable bit	U = Unimplemented bit, read as '0'
-n = Value at POR	'1' = Bit is set	'0' = Bit is cleared x = Bit is unknown

bit 15-0 **SPHASE_x<15:0>**: Secondary Phase Offset for PWM_xL Output Pin bits
(used in Independent PWM mode only)

Note 1: If PWMCON_x<ITB> = 0, the following applies based on the mode of operation:

- Complementary, Redundant and Push-Pull Output mode (PMOD<1:0> (IOCON_x<11:10>) = 00, 01 or 10); SPHASE_x<15:0> = Not used
- True Independent Output mode (IOCON_x<PMOD> = 11); PHASE_x<15:0> = Phase-shift value for PWM_xL only

2: If PWMCON_x<ITB> = 1, the following applies based on the mode of operation:

- Complementary, Redundant and Push-Pull Output mode (IOCON_x<PMOD> = 00, 01, or 10); SPHASE_x<15:0> = Not used
- True Independent Output mode (PMOD<1:0> (IOCON_x<11:10>) = 11); PHASE_x<15:0> = Independent Time Base period value for PWM_xL only

dsPIC33FJ06GS101/X02 and dsPIC33FJ16GSX02/X04

REGISTER 15-11: DTRx: PWMx DEAD-TIME REGISTER

U-0	U-0	R/W-0	R/W-0	R/W-0	R/W-0	R/W-0	R/W-0
—	—	DTRx<13:8>					
bit 15							bit 8

R/W-0	R/W-0	R/W-0	R/W-0	R/W-0	R/W-0	R/W-0	R/W-0
DTRx<7:0>							
bit 7							bit 0

Legend:

R = Readable bit W = Writable bit U = Unimplemented bit, read as '0'
 -n = Value at POR '1' = Bit is set '0' = Bit is cleared x = Bit is unknown

bit 15-14 **Unimplemented:** Read as '0'

bit 13-0 **DTRx<13:0>:** Unsigned 14-Bit Dead-Time Value for PWMx Dead-Time Unit bits

REGISTER 15-12: ALTDTRx: PWMx ALTERNATE DEAD-TIME REGISTER

U-0	U-0	R/W-0	R/W-0	R/W-0	R/W-0	R/W-0	R/W-0
—	—	ALTDTRx<13:8>					
bit 15							bit 8

R/W-0	R/W-0	R/W-0	R/W-0	R/W-0	R/W-0	R/W-0	R/W-0
ALTDTR <7:0>							
bit 7							bit 0

Legend:

R = Readable bit W = Writable bit U = Unimplemented bit, read as '0'
 -n = Value at POR '1' = Bit is set '0' = Bit is cleared x = Bit is unknown

bit 15-14 **Unimplemented:** Read as '0'

bit 13-0 **ALTDTRx<13:0>:** Unsigned 14-Bit Dead-Time Value for PWMx Dead-Time Unit bits

dsPIC33FJ06GS101/X02 and dsPIC33FJ16GSX02/X04

REGISTER 15-13: TRGCONx: PWMx TRIGGER CONTROL REGISTER

R/W-0	R/W-0	R/W-0	R/W-0	U-0	U-0	U-0	U-0
TRGDIV3	TRGDIV2	TRGDIV1	TRGDIV0	—	—	—	—
bit 15							bit 8

R/W-0	U-0	R/W-0	R/W-0	R/W-0	R/W-0	R/W-0	R/W-0
DTM ⁽¹⁾	—	TRGSTR5	TRGSTR4	TRGSTR3	TRGSTR2	TRGSTR1	TRGSTR0
bit 7							bit 0

Legend:

R = Readable bit W = Writable bit U = Unimplemented bit, read as '0'
 -n = Value at POR '1' = Bit is set '0' = Bit is cleared x = Bit is unknown

bit 15-12 **TRGDIV<3:0>**: Trigger # Output Divider bits
 1111 = Trigger output for every 16th trigger event
 1110 = Trigger output for every 15th trigger event
 1101 = Trigger output for every 14th trigger event
 1100 = Trigger output for every 13th trigger event
 1011 = Trigger output for every 12th trigger event
 1010 = Trigger output for every 11th trigger event
 1001 = Trigger output for every 10th trigger event
 1000 = Trigger output for every 9th trigger event
 0111 = Trigger output for every 8th trigger event
 0110 = Trigger output for every 7th trigger event
 0101 = Trigger output for every 6th trigger event
 0100 = Trigger output for every 5th trigger event
 0011 = Trigger output for every 4th trigger event
 0010 = Trigger output for every 3rd trigger event
 0001 = Trigger output for every 2nd trigger event
 0000 = Trigger output for every trigger event

bit 11-8 **Unimplemented**: Read as '0'

bit 7 **DTM**: Dual Trigger Mode bit⁽¹⁾
 1 = Secondary trigger event is combined with the primary trigger event to create the PWM trigger.
 0 = Secondary trigger event is not combined with the primary trigger event to create the PWM trigger;
 two separate PWM triggers are generated

bit 6 **Unimplemented**: Read as '0'

bit 5-0 **TRGSTR<5:0>**: Trigger Postscaler Start Enable Select bits
 111111 = Wait 63 PWM cycles before generating the first trigger event after the module is enabled
 •
 •
 •
 000010 = Wait 1 PWM cycles before generating the first trigger event after the module is enabled
 000001 = Wait 1 PWM cycle before generating the first trigger event after the module is enabled
 000000 = Wait 0 PWM cycles before generating the first trigger event after the module is enabled

Note 1: The secondary generator cannot generate PWM trigger interrupts.

dsPIC33FJ06GS101/X02 and dsPIC33FJ16GSX02/X04

REGISTER 15-14: IOCONx: PWMx I/O CONTROL REGISTER

R/W-0	R/W-0	R/W-0	R/W-0	R/W-0	R/W-0	R/W-0	R/W-0
PENH	PENL	POLH	POLL	PMOD1 ⁽¹⁾	PMOD0 ⁽¹⁾	OVRENH	OVRENL
bit 15						bit 8	

R/W-0	R/W-0	R/W-0	R/W-0	R/W-0	R/W-0	R/W-0	R/W-0
OVRDAT1	OVRDAT0	FLTDAT1 ⁽²⁾	FLTDAT0 ⁽²⁾	CLDAT1 ⁽²⁾	CLDAT0 ⁽²⁾	SWAP	OSYNC
bit 7						bit 0	

Legend:

R = Readable bit W = Writable bit U = Unimplemented bit, read as '0'
 -n = Value at POR '1' = Bit is set '0' = Bit is cleared x = Bit is unknown

- bit 15 **PENH:** PWMH Output Pin Ownership bit
 1 = PWM module controls the PWMxH pin
 0 = GPIO module controls the PWMxH pin
- bit 14 **PENL:** PWML Output Pin Ownership bit
 1 = PWM module controls the PWMxL pin
 0 = GPIO module controls the PWMxL pin
- bit 13 **POLH:** PWMH Output Pin Polarity bit
 1 = PWMxH pin is active-low
 0 = PWMxH pin is active-high
- bit 12 **POLL:** PWML Output Pin Polarity bit
 1 = PWMxL pin is active-low
 0 = PWMxL pin is active-high
- bit 11-10 **PMOD<1:0>:** PWM # I/O Pin Mode bits⁽¹⁾
 11 = PWM I/O pin pair is in the True Independent Output mode
 10 = PWM I/O pin pair is in the Push-Pull Output mode
 01 = PWM I/O pin pair is in the Redundant Output mode
 00 = PWM I/O pin pair is in the Complementary Output mode
- bit 9 **OVRENH:** Override Enable for PWMxH Pin bit
 1 = OVRDAT<1> provides data for output on the PWMxH pin
 0 = PWM generator provides data for the PWMxH pin
- bit 8 **OVRENL:** Override Enable for PWMxL Pin bit
 1 = OVRDAT<0> provides data for output on the PWMxL pin
 0 = PWM generator provides data for the PWMxL pin
- bit 7-6 **OVRDAT<1:0>:** Data for PWMxH and PWMxL Pins if Override is Enabled bits
 If OVERENH = 1, then OVRDAT<1> provides data for PWMxH
 If OVERENL = 1, then OVRDAT<0> provides data for PWMxL
- bit 5-4 **FLTDAT<1:0>:** State for PWMxH and PWMxL Pins if FLTMOD is Enabled bits⁽²⁾
 FCLCONx<IFLTMOD> = 0: Normal Fault mode:
 If Fault is active, then FLTDAT<1> provides the state for PWMxH
 If Fault is active, then FLTDAT<0> provides the state for PWMxL
 FCLCONx<IFLTMOD> = 1: Independent Fault mode:
 If current-limit is active, then FLTDAT<1> provides data for PWMxH
 If Fault is active, then FLTDAT<0> provides the state for PWMxL

- Note 1:** These bits should be changed only when PTEN = 0. Changing the clock selection during operation will yield unpredictable results.
- 2:** The state represents the active/inactive state of the PWM module depending on the POLH and POLL bit settings.

dsPIC33FJ06GS101/X02 and dsPIC33FJ16GSX02/X04

REGISTER 15-14: IOCONx: PWMx I/O CONTROL REGISTER (CONTINUED)

- bit 3-2 **CLDAT<1:0>**: State for PWMxH and PWMxL Pins if CLMODE is Enabled bits⁽²⁾
FCLCONx<IFLTMOD> = 0: Normal Fault mode:
If current-limit is active, then CLDAT<1> provides the state for PWMxH
If current-limit is active, then CLDAT<0> provides the state for PWMxL
FCLCONx<IFLTMOD> = 1: Independent Fault mode:
CLDAT<1:0> bits are ignored.
- bit 1 **SWAP<1:0>**: Swap PWMxH and PWMxL pins
1 = PWMxH output signal is connected to the PWMxL pin and the PWMxL signal is connected to the PWMxH pins
0 = PWMxH and PWMxL pins are mapped to their respective pins
- bit 0 **OSYNC**: Output Override Synchronization bit
1 = Output overrides via the OVRDAT<1:0> bits are synchronized to the PWM time base
0 = Output overrides via the OVDDAT<1:0> bits occur on the next CPU clock boundary

- Note 1:** These bits should be changed only when PTEN = 0. Changing the clock selection during operation will yield unpredictable results.
- 2:** The state represents the active/inactive state of the PWM module depending on the POLH and POLL bit settings.

dsPIC33FJ06GS101/X02 and dsPIC33FJ16GSX02/X04

REGISTER 15-15: FCLCONx: PWMx FAULT CURRENT-LIMIT CONTROL REGISTER

R/W-0	R/W-0	R/W-0	R/W-0	R/W-0	R/W-0	R/W-0	R/W-0
IFLTMOD	CLSRC4 ^(2,3)	CLSRC3 ^(2,3)	CLSRC2 ^(2,3)	CLSRC1 ^(2,3)	CLSRC0 ^(2,3)	CLPOL ⁽¹⁾	CLMOD
bit 15						bit 8	

R/W-0	R/W-0	R/W-0	R/W-0	R/W-0	R/W-0	R/W-0	R/W-0
FLTSRC4 ^(2,3)	FLTSRC3 ^(2,3)	FLTSRC2 ^(2,3)	FLTSRC1 ^(2,3)	FLTSRC0 ^(2,3)	FLTPOL ⁽¹⁾	FLTMOD1	FLTMOD0
bit 7						bit 0	

Legend:

R = Readable bit W = Writable bit U = Unimplemented bit, read as '0'
-n = Value at POR '1' = Bit is set '0' = Bit is cleared x = Bit is unknown

- bit 15 **IFLTMOD:** Independent Fault Mode Enable bit
1 = Independent Fault mode: Current-limit input maps FLTDAT1 to PWMxH output and the Fault input maps FLTDAT0 to the PWMxL output. The CLDAT<1:0> bits are not used for override functions.
0 = Normal Fault mode: Current-limit feature maps CLDAT<1:0> bits to the PWMxH and PWMxL outputs. The PWM Fault feature maps FLTDAT<1:0> to the PWMxH and PWMxL outputs.
- bit 14-10 **CLSRC<4:0>:** Current-Limit Control Signal Source Select for PWM # Generator bits^(2,3)
11111 = Reserved
•
•
•
01000 = Reserved
00111 = Fault 8
00110 = Fault 7
00101 = Fault 6
00100 = Fault 5
00011 = Fault 4
00010 = Fault 3
00001 = Fault 2
00000 = Fault 1
- bit 9 **CLPOL:** Current-Limit Polarity for PWM Generator # bit⁽¹⁾
1 = The selected current-limit source is active-low
0 = The selected current-limit source is active-high
- bit 8 **CLMOD:** Current-Limit Mode Enable bit for PWM Generator # bit
1 = Current-limit function is enabled
0 = Current-limit function is disabled

- Note 1:** These bits should be changed only when PTEN = 0. Changing the clock selection during operation will yield unpredictable results.
- 2:** When Independent Fault mode is enabled (IFLTMOD = 1), and Fault 1 is used for Current-Limit mode (CLSRC<4:0> = b0000), the Fault Control Source Select bits (FLTSRC<4:0>) should be set to an unused Fault source to prevent Fault 1 from disabling both the PWMxL and PWMxH outputs.
- 3:** When Independent Fault mode is enabled (IFLTMOD = 1) and Fault 1 is used for Fault mode (FLTSRC<4:0> = b0000), the Current-Limit Control Source Select bits (CLSRC<4:0>) should be set to an unused current-limit source to prevent the current-limit source from disabling both the PWMxH and PWMxL outputs.

dsPIC33FJ06GS101/X02 and dsPIC33FJ16GSX02/X04

REGISTER 15-15: FCLCONx: PWMx FAULT CURRENT-LIMIT CONTROL REGISTER (CONTINUED)

bit 7-3	FLTSRC<4:0> : Fault Control Signal Source Select for PWM Generator # bits ^(2,3) 11111 = Reserved • • • 01000 = Reserved 00111 = Fault 8 00110 = Fault 7 00101 = Fault 6 00100 = Fault 5 00011 = Fault 4 00010 = Fault 3 00001 = Fault 2 00000 = Fault 1
bit 2	FLTPOL : Fault Polarity for PWM Generator # bit ⁽¹⁾ 1 = The selected Fault source is active-low 0 = The selected Fault source is active-high
bit 1-0	FLTMOD<1:0> : Fault Mode for PWM Generator # bits 11 = Fault input is disabled 10 = Reserved 01 = The selected Fault source forces the PWMxH and PWMxL pins to FLTDAT values (cycle) 00 = The selected Fault source forces the PWMxH and PWMxL pins to FLTDAT values (latched condition)

- Note 1:** These bits should be changed only when PTEN = 0. Changing the clock selection during operation will yield unpredictable results.
- 2:** When Independent Fault mode is enabled (IFLTMOD = 1), and Fault 1 is used for Current-Limit mode (CLSRC<4:0> = b0000), the Fault Control Source Select bits (FLTSRC<4:0>) should be set to an unused Fault source to prevent Fault 1 from disabling both the PWMxL and PWMxH outputs.
- 3:** When Independent Fault mode is enabled (IFLTMOD = 1) and Fault 1 is used for Fault mode (FLTSRC<4:0> = b0000), the Current-Limit Control Source Select bits (CLSRC<4:0>) should be set to an unused current-limit source to prevent the current-limit source from disabling both the PWMxH and PWMxL outputs.

dsPIC33FJ06GS101/X02 and dsPIC33FJ16GSX02/X04

REGISTER 15-16: TRIGx: PWMx PRIMARY TRIGGER COMPARE VALUE REGISTER

R/W-0	R/W-0	R/W-0	R/W-0	R/W-0	R/W-0	R/W-0	R/W-0
TRGCMP<15:8>							
bit 15							
bit 8							

R/W-0	R/W-0	R/W-0	R/W-0	R/W-0	U-0	U-0	U-0
TRGCMP<7:3>					—	—	—
bit 7							
bit 0							

Legend:

R = Readable bit W = Writable bit U = Unimplemented bit, read as '0'
 -n = Value at POR '1' = Bit is set '0' = Bit is cleared x = Bit is unknown

bit 15-3 **TRGCMP<15:3>**: Trigger Control Value bits
 When primary PWM functions in the local time base, this register contains the compare values that can trigger the ADC module.

bit 2-0 **Unimplemented**: Read as '0'

REGISTER 15-17: STRIGx: PWMx SECONDARY TRIGGER COMPARE VALUE REGISTER

R/W-0	R/W-0	R/W-0	R/W-0	R/W-0	R/W-0	R/W-0	R/W-0
STRGCMP<15:8>							
bit 15							
bit 8							

R/W-0	R/W-0	R/W-0	R/W-0	R/W-0	U-0	U-0	U-0
STRGCMP<7:3>					—	—	—
bit 7							
bit 0							

Legend:

R = Readable bit W = Writable bit U = Unimplemented bit, read as '0'
 -n = Value at POR '1' = Bit is set '0' = Bit is cleared x = Bit is unknown

bit 15-3 **STRGCMP<15:3>**: Secondary Trigger Control Value bits
 When secondary PWM functions in the local time base, this register contains the compare values that can trigger the ADC module.

bit 2-0 **Unimplemented**: Read as '0'

dsPIC33FJ06GS101/X02 and dsPIC33FJ16GSX02/X04

REGISTER 15-18: LEBCONx: LEADING-EDGE BLANKING CONTROL REGISTER⁽¹⁾

R/W-0	R/W-0	R/W-0	R/W-0	R/W-0	R/W-0	R/W-0	R/W-0
PHR	PHF	PLR	PLF	FLTLEBEN	CLLEBEN	LEB6	LEB5
bit 15						bit 8	

R/W-0	R/W-0	R/W-0	R/W-0	R/W-0	U-0	U-0	U-0
LEB4	LEB3	LEB2	LEB1	LEB0	—	—	—
bit 7						bit 0	

Legend:

R = Readable bit	W = Writable bit	U = Unimplemented bit, read as '0'
-n = Value at POR	'1' = Bit is set	'0' = Bit is cleared
		x = Bit is unknown

- bit 15 **PHR:** PWMxH Rising Edge Trigger Enable bit
1 = Rising edge of PWMxH will trigger the LEB counter
0 = LEB ignores the rising edge of PWMxH
- bit 14 **PHF:** PWMH Falling Edge Trigger Enable bit
1 = Falling edge of PWMxH will trigger the LEB counter
0 = LEB ignores the falling edge of PWMxH
- bit 13 **PLR:** PWML Rising Edge Trigger Enable bit
1 = Rising edge of PWMxL will trigger the LEB counter
0 = LEB ignores the rising edge of PWMxL
- bit 12 **PLF:** PWML Falling Edge Trigger Enable bit
1 = Falling edge of PWMxL will trigger the LEB counter
0 = LEB ignores the falling edge of PWMxL
- bit 11 **FLTLEBEN:** Fault Input LEB Enable bit
1 = Leading-Edge Blanking is applied to selected Fault input
0 = Leading-Edge Blanking is not applied to selected Fault input
- bit 10 **CLLEBEN:** Current-Limit LEB Enable bit
1 = Leading-Edge Blanking is applied to selected current-limit input
0 = Leading-Edge Blanking is not applied to selected current-limit input
- bit 9-3 **LEB<6:0>:** Leading-Edge Blanking for Current-Limit and Fault Inputs bits
The value is 8.32 nsec increments.
- bit 2-0 **Unimplemented:** Read as '0'

Note 1: Configure this register in word format.

dsPIC33FJ06GS101/X02 and dsPIC33FJ16GSX02/X04

REGISTER 15-19: PWMCAPx: PRIMARY PWMx TIME BASE CAPTURE REGISTER

R-0	R-0	R-0	R-0	R-0	R-0	R-0	R-0
PWMCAP<15:8> ^(1,2)							
bit 15							bit 8

R-0	R-0	R-0	R-0	R-0	U-0	U-0	U-0
PWMCAP<7:3> ^(1,2)					—	—	—
bit 7							bit 0

Legend:

R = Readable bit	W = Writable bit	U = Unimplemented bit, read as '0'
-n = Value at POR	'1' = Bit is set	'0' = Bit is cleared
		x = Bit is unknown

- bit 15-3 **PWMCAP<15:3>**: Captured PWM Time Base Value bits^(1,2)
 The value in this register represents the captured PWM time base value when a leading edge is detected on the current-limit input.
- bit 2-0 **Unimplemented**: Read as '0'

- Note 1:** The capture feature is only available on the primary output (PWMxH).
Note 2: This feature is active only after LEB processing on the current-limit input signal is complete.

dsPIC33FJ06GS101/X02 and dsPIC33FJ16GSX02/X04

16.0 SERIAL PERIPHERAL INTERFACE (SPI)

Note 1: This data sheet summarizes the features of the dsPIC33FJ06GS101/X02 and dsPIC33FJ16GSX02/X04 families of devices. It is not intended to be a comprehensive reference source. To complement the information in this data sheet, refer to “**Serial Peripheral Interface (SPI)**” (DS70206) in the “*dsPIC33F/PIC24H Family Reference Manual*”, which is available on the Microchip web site (www.microchip.com).

2: Some registers and associated bits described in this section may not be available on all devices. Refer to **Section 4.0 “Memory Organization”** in this data sheet for device-specific register and bit information.

The Serial Peripheral Interface (SPI) module is a synchronous serial interface useful for communicating with other peripheral or microcontroller devices. These peripheral devices can be serial EEPROMs, shift registers, display drivers, Analog-to-Digital Converters and so on. The SPI module is compatible with SPI and SIO_P from Motorola®.

The SPI module consists of a 16-bit shift register, SPI_xSR (where x = 1), used for shifting data in and out, and a buffer register, SPI_xBUF. A control register, SPI_xCON, configures the module. Additionally, a status register, SPI_xSTAT, indicates status conditions.

The serial interface consists of the following four pins:

- SDI_x (Serial Data Input)
- SDO_x (Serial Data Output)
- SCK_x (Shift Clock Input Or Output)
- SS_x (Active-Low Slave Select).

In Master mode operation, SCK is a clock output; in Slave mode, it is a clock input.

FIGURE 16-1: SPI_x MODULE BLOCK DIAGRAM



dsPIC33FJ06GS101/X02 and dsPIC33FJ16GSX02/X04

REGISTER 16-1: SPIxSTAT: SPIx STATUS AND CONTROL REGISTER

R/W-0	U-0	R/W-0	U-0	U-0	U-0	U-0	U-0
SPIEN	—	SPISIDL	—	—	—	—	—
bit 15						bit 8	

U-0	R/C-0	U-0	U-0	U-0	U-0	R-0	R-0
—	SPIROV	—	—	—	—	SPITBF	SPIRBF
bit 7						bit 0	

Legend:	C = Clearable bit		
R = Readable bit	W = Writable bit	U = Unimplemented bit, read as '0'	
-n = Value at POR	'1' = Bit is set	'0' = Bit is cleared	x = Bit is unknown

- bit 15 **SPIEN:** SPIx Enable bit
1 = Enables module and configures SCKx, SDOx, SDIx and \overline{SSx} as serial port pins
0 = Disables module
- bit 14 **Unimplemented:** Read as '0'
- bit 13 **SPISIDL:** SPIx Stop in Idle Mode bit
1 = Discontinues module operation when device enters Idle mode
0 = Continues module operation in Idle mode
- bit 12-7 **Unimplemented:** Read as '0'
- bit 6 **SPIROV:** SPIx Receive Overflow Flag bit
1 = A new byte/word is completely received and discarded. The user software has not read the previous data in the SPIxBUF register.
0 = No overflow has occurred
- bit 5-2 **Unimplemented:** Read as '0'
- bit 1 **SPITBF:** SPIx Transmit Buffer Full Status bit
1 = Transmit not yet started, SPIxTXB is full
0 = Transmit started, SPIxTXB is empty. Automatically set in hardware when CPU writes the SPIxBUF location, loading SPIxTXB. Automatically cleared in hardware when the SPIx module transfers data from SPIxTXB to SPIxSR.
- bit 0 **SPIRBF:** SPIx Receive Buffer Full Status bit
1 = Receive complete, SPIxRXB is full
0 = Receive is not complete, SPIxRXB is empty. Automatically set in hardware when SPIx transfers data from SPIxSR to SPIxRXB. Automatically cleared in hardware when core reads the SPIxBUF location, reading SPIxRXB.

dsPIC33FJ06GS101/X02 and dsPIC33FJ16GSX02/X04

REGISTER 16-2: SPIxCON1: SPIx CONTROL REGISTER 1

U-0	U-0	U-0	R/W-0	R/W-0	R/W-0	R/W-0	R/W-0
—	—	—	DISSCK	DISSDO	MODE16	SMP	CKE ⁽¹⁾
bit 15							bit 8

R/W-0	R/W-0	R/W-0	R/W-0	R/W-0	R/W-0	R/W-0	R/W-0
SSEN ⁽³⁾	CKP	MSTEN	SPRE2 ⁽²⁾	SPRE1 ⁽²⁾	SPRE0 ⁽²⁾	PPRE1 ⁽²⁾	PPRE0 ⁽²⁾
bit 7							bit 0

Legend:

R = Readable bit W = Writable bit U = Unimplemented bit, read as '0'
 -n = Value at POR '1' = Bit is set '0' = Bit is cleared x = Bit is unknown

- bit 15-13 **Unimplemented:** Read as '0'
- bit 12 **DISSCK:** Disable SCKx Pin bit (SPI Master modes only)
 1 = Internal SPI clock is disabled; pin functions as I/O
 0 = Internal SPI clock is enabled
- bit 11 **DISSDO:** Disable SDOx Pin bit
 1 = SDOx pin is not used by module; pin functions as I/O
 0 = SDOx pin is controlled by the module
- bit 10 **MODE16:** Word/Byte Communication Select bit
 1 = Communication is word-wide (16 bits)
 0 = Communication is byte-wide (8 bits)
- bit 9 **SMP:** SPIx Data Input Sample Phase bit
 Master mode:
 1 = Input data sampled at end of data output time
 0 = Input data sampled at middle of data output time
 Slave mode:
 SMP must be cleared when SPIx is used in Slave mode.
- bit 8 **CKE:** SPIx Clock Edge Select bit⁽¹⁾
 1 = Serial output data changes on transition from active clock state to Idle clock state (see bit 6)
 0 = Serial output data changes on transition from Idle clock state to active clock state (see bit 6)
- bit 7 **SSEN:** Slave Select Enable bit (Slave mode)⁽³⁾
 1 = \overline{SSx} pin is used for Slave mode
 0 = \overline{SSx} pin is not used by module; pin controlled by port function
- bit 6 **CKP:** Clock Polarity Select bit
 1 = Idle state for clock is a high level; active state is a low level
 0 = Idle state for clock is a low level; active state is a high level
- bit 5 **MSTEN:** Master Mode Enable bit
 1 = Master mode
 0 = Slave mode

- Note 1:** The CKE bit is not used in the Framed SPI modes. Program this bit to '0' for the Framed SPI modes (FRMEN = 1).
- 2:** Do not set both primary and secondary prescalers to a value of 1:1.
- 3:** This bit must be cleared when FRMEN = 1.

dsPIC33FJ06GS101/X02 and dsPIC33FJ16GSX02/X04

REGISTER 16-2: SPIxCON1: SPIx CONTROL REGISTER 1 (CONTINUED)

bit 4-2 **SPRE<2:0>**: Secondary Prescale bits (Master mode)⁽²⁾

111 = Secondary prescale 1:1

110 = Secondary prescale 2:1

•

•

•

000 = Secondary prescale 8:1

bit 1-0 **PPRE<1:0>**: Primary Prescale bits (Master mode)⁽²⁾

11 = Primary prescale 1:1

10 = Primary prescale 4:1

01 = Primary prescale 16:1

00 = Primary prescale 64:1

Note 1: The CKE bit is not used in the Framed SPI modes. Program this bit to '0' for the Framed SPI modes (FRMEN = 1).

2: Do not set both primary and secondary prescalers to a value of 1:1.

3: This bit must be cleared when FRMEN = 1.

dsPIC33FJ06GS101/X02 and dsPIC33FJ16GSX02/X04

REGISTER 16-3: SPIxCON2: SPIx CONTROL REGISTER 2

R/W-0	R/W-0	R/W-0	U-0	U-0	U-0	U-0	U-0
FRMEN	SPIFSD	FRMPOL	—	—	—	—	—
bit 15						bit 8	

U-0	U-0	U-0	U-0	U-0	U-0	R/W-0	U-0
—	—	—	—	—	—	FRMDLY	—
bit 7						bit 0	

Legend:

R = Readable bit	W = Writable bit	U = Unimplemented bit, read as '0'
-n = Value at POR	'1' = Bit is set	'0' = Bit is cleared
		x = Bit is unknown

- bit 15 **FRMEN:** Framed SPIx Support bit
 1 = Framed SPIx support is enabled (\overline{SSx} pin used as frame sync pulse input/output)
 0 = Framed SPIx support is disabled
- bit 14 **SPIFSD:** SPIx Frame Sync Pulse Direction Control bit
 1 = Frame sync pulse input (slave)
 0 = Frame sync pulse output (master)
- bit 13 **FRMPOL:** Frame Sync Pulse Polarity bit
 1 = Frame sync pulse is active-high
 0 = Frame sync pulse is active-low
- bit 12-2 **Unimplemented:** Read as '0'
- bit 1 **FRMDLY:** Frame Sync Pulse Edge Select bit
 1 = Frame sync pulse coincides with first bit clock
 0 = Frame sync pulse precedes first bit clock
- bit 0 **Unimplemented:** This bit must not be set to '1' by the user application

dsPIC33FJ06GS101/X02 and dsPIC33FJ16GSX02/X04

NOTES:

17.0 INTER-INTEGRATED CIRCUIT (I²C™)

Note 1: This data sheet summarizes the features of the dsPIC33FJ06GS101/X02 and dsPIC33FJ16GSX02/X04 families of devices. It is not intended to be a comprehensive reference source. To complement the information in this data sheet, refer to “**Inter-Integrated Circuit (I²C™)**” (DS70000195) in the “*dsPIC33/PIC24 Family Reference Manual*”, which is available on the Microchip web site (www.microchip.com).

2: Some registers and associated bits described in this section may not be available on all devices. Refer to **Section 4.0 “Memory Organization”** in this data sheet for device-specific register and bit information.

The Inter-Integrated Circuit (I²C) module provides complete hardware support for both Slave and Multi-Master modes of the I²C serial communication standard with a 16-bit interface.

The I²C module has a 2-pin interface, where:

- The SCLx pin is clock
- The SDAx pin is data

The I²C module offers the following key features:

- I²C interface supporting both Master and Slave modes of operation
- I²C Slave mode supports 7-bit and 10-bit addressing
- I²C Master mode supports 7-bit and 10-bit addressing
- I²C port allows bidirectional transfers between master and slaves
- Serial clock synchronization for I²C port can be used as a handshake mechanism to suspend and resume serial transfer (SCLREL control)
- I²C supports multi-master operation, detects bus collision and arbitrates accordingly

17.1 Operating Modes

The hardware fully implements all the master and slave functions of the I²C Standard and Fast mode specifications, as well as 7-bit and 10-bit addressing.

The I²C module can operate either as a slave or a master on an I²C bus.

The following types of I²C operation are supported:

- I²C slave operation with 7-bit addressing
- I²C slave operation with 10-bit addressing
- I²C master operation with 7-bit or 10-bit addressing

dsPIC33FJ06GS101/X02 and dsPIC33FJ16GSX02/X04

FIGURE 17-1: I2Cx BLOCK DIAGRAM (x = 1)



17.2 I²C Registers

I2CxCON and I2CxSTAT are control and status registers. The I2CxCON register is readable and writable. The lower six bits of I2CxSTAT are read-only. The remaining bits of the I2CxSTAT are read/write:

- I2CxRSR is the shift register used for shifting data internal to the module and the user application has no access to it
- I2CxRCV is the receive buffer and the register to which data bytes are written, or from which data bytes are read
- I2CxTRN is the transmit register to which bytes are written during a transmit operation
- The I2CxADD register holds the slave address
- A status bit, ADD10, indicates 10-Bit Addressing mode
- The I2CxBRG acts as the Baud Rate Generator (BRG) reload value

In receive operations, I2CxRSR and I2CxRCV together form a double-buffered receiver. When I2CxRSR receives a complete byte, it is transferred to I2CxRCV, and an interrupt pulse is generated.

dsPIC33FJ06GS101/X02 and dsPIC33FJ16GSX02/X04

REGISTER 17-1: I2CxCON: I2Cx CONTROL REGISTER

R/W-0	U-0	R/W-0	R/W-1, HC	R/W-0	R/W-0	R/W-0	R/W-0
I2CEN	—	I2CSIDL	SCLREL	IPMIEN	A10M	DISSLW	SMEN
bit 15							bit 8

R/W-0	R/W-0	R/W-0	R/W-0, HC	R/W-0, HC	R/W-0, HC	R/W-0, HC	R/W-0, HC
GCEN	STREN	ACKDT	ACKEN	RCEN	PEN	RSEN	SEN
bit 7							bit 0

Legend:	U = Unimplemented bit, read as '0'						
R = Readable bit	W = Writable bit	HC = Hardware Clearable bit					
-n = Value at POR	'1' = Bit is set	'0' = Bit is cleared			x = Bit is unknown		

- bit 15 **I2CEN:** I2Cx Enable bit
 1 = Enables the I2Cx module, and configures the SDAx and SCLx pins as serial port pins
 0 = Disables the I2Cx module; all I²C™ pins are controlled by port functions.
- bit 14 **Unimplemented:** Read as '0'
- bit 13 **I2CSIDL:** I2Cx Stop in Idle Mode bit
 1 = Discontinues module operation when device enters an Idle mode
 0 = Continues module operation in Idle mode
- bit 12 **SCLREL:** SCLx Release Control bit (when operating as I²C slave)
 1 = Releases SCLx clock
 0 = Holds SCLx clock low (clock stretch)
If STREN = 1:
 Bit is R/W (i.e., software can write '0' to initiate stretch and write '1' to release clock). Hardware clear at beginning of slave transmission. Hardware clear at end of slave reception.
If STREN = 0:
 Bit is R/S (i.e., software can only write '1' to release clock). Hardware clear at beginning of slave transmission.
- bit 11 **IPMIEN:** Intelligent Peripheral Management Interface (IPMI) Enable bit
 1 = IPMI mode is enabled; all addresses are Acknowledged
 0 = IPMI mode is disabled
- bit 10 **A10M:** 10-Bit Slave Address bit
 1 = I2CxADD is a 10-bit slave address
 0 = I2CxADD is a 7-bit slave address
- bit 9 **DISSLW:** Disable Slew Rate Control bit
 1 = Slew rate control is disabled
 0 = Slew rate control is enabled
- bit 8 **SMEN:** SMBus Input Levels bit
 1 = Enables I/O pin thresholds compliant with SMBus specification
 0 = Disables SMBus input thresholds
- bit 7 **GCEN:** General Call Enable bit (when operating as I²C slave)
 1 = Enables interrupt when a general call address is received in the I2CxRSR (module is enabled for reception)
 0 = General call address is disabled
- bit 6 **STREN:** SCLx Clock Stretch Enable bit (when operating as I²C slave)
 Used in conjunction with the SCLREL bit.
 1 = Enables software or receive clock stretching
 0 = Disables software or receive clock stretching

dsPIC33FJ06GS101/X02 and dsPIC33FJ16GSX02/X04

REGISTER 17-1: I2CxCON: I2Cx CONTROL REGISTER (CONTINUED)

- bit 5 **ACKDT:** Acknowledge Data bit (when operating as I²C master, applicable during master receive)
Value that is transmitted when the software initiates an Acknowledge sequence.
1 = Sends NACK during Acknowledge
0 = Sends ACK during Acknowledge
- bit 4 **ACKEN:** Acknowledge Sequence Enable bit
(when operating as I²C master, applicable during master receive)
1 = Initiates Acknowledge sequence on SDAx and SCLx pins and transmits the ACKDT data bit.
Hardware is clear at end of master Acknowledge sequence.
0 = Acknowledge sequence is not in progress
- bit 3 **RCEN:** Receive Enable bit (when operating as I²C master)
1 = Enables Receive mode for I²C. Hardware is clear at end of eighth bit of master receive data byte.
0 = Receive sequence is not in progress
- bit 2 **PEN:** Stop Condition Enable bit (when operating as I²C master)
1 = Initiates Stop condition on SDAx and SCLx pins. Hardware is clear at end of master Stop sequence.
0 = Stop condition is not in progress
- bit 1 **RSEN:** Repeated Start Condition Enable bit (when operating as I²C master)
1 = Initiates Repeated Start condition on SDAx and SCLx pins. Hardware is clear at end of master
Repeated Start sequence.
0 = Repeated Start condition is not in progress
- bit 0 **SEN:** Start Condition Enable bit (when operating as I²C master)
1 = Initiates Start condition on SDAx and SCLx pins. Hardware is clear at end of master Start
sequence.
0 = Start condition is not in progress

dsPIC33FJ06GS101/X02 and dsPIC33FJ16GSX02/X04

REGISTER 17-2: I2CxSTAT: I2Cx STATUS REGISTER

R-0, HSC	R-0, HSC	U-0	U-0	U-0	R/C-0, HSC	R-0, HSC	R-0, HSC
ACKSTAT	TRSTAT	—	—	—	BCL	GCSTAT	ADD10
bit 15						bit 8	

R/C-0, HS	R/C-0, HS	R-0, HSC	R/C-0, HSC	R/C-0, HSC	R-0, HSC	R-0, HSC	R-0, HSC
IWCOL	I2COV	D_A	P	S	R_W	RBF	TBF
bit 7						bit 0	

Legend:	C = Clearable bit	HSC = Hardware Settable/Clearable bit
R = Readable bit	W = Writable bit	U = Unimplemented bit, read as '0'
-n = Value at POR	'1' = Bit is set	'0' = Bit is cleared
HS = Hardware Settable bit		x = Bit is unknown

- bit 15 **ACKSTAT:** Acknowledge Status bit
(when operating as I²C™ master, applicable to master transmit operation)
1 = NACK received from slave
0 = ACK received from slave
Hardware is set or clear at end of slave Acknowledge.
- bit 14 **TRSTAT:** Transmit Status bit (when operating as I²C master, applicable to master transmit operation)
1 = Master transmit is in progress (8 bits + ACK)
0 = Master transmit is not in progress
Hardware is set at beginning of master transmission. Hardware is clear at end of slave Acknowledge.
- bit 13-11 **Unimplemented:** Read as '0'
- bit 10 **BCL:** Master Bus Collision Detect bit
1 = A bus collision has been detected during a master operation
0 = No collision
Hardware is set at detection of bus collision.
- bit 9 **GCSTAT:** General Call Status bit
1 = General call address was received
0 = General call address was not received
Hardware is set when address matches general call address. Hardware is clear at Stop detection.
- bit 8 **ADD10:** 10-Bit Address Status bit
1 = 10-bit address was matched
0 = 10-bit address was not matched
Hardware is set at match of 2nd byte of matched 10-bit address. Hardware is clear at Stop detection.
- bit 7 **IWCOL:** I2Cx Write Collision Detect bit
1 = An attempt to write to the I2CxTRN register failed because the I²C module is busy
0 = No collision
Hardware is set at occurrence of write to I2CxTRN while busy (cleared by software).
- bit 6 **I2COV:** I2Cx Receive Overflow Flag bit
1 = A byte was received while the I2CxRCV register is still holding the previous byte
0 = No overflow
Hardware is set at attempt to transfer I2CxRSR to I2CxRCV (cleared by software).
- bit 5 **D_A:** Data/Address bit (when operating as I²C slave)
1 = Indicates that the last byte received was data
0 = Indicates that the last byte received was a device address
Hardware is clear at device address match. Hardware is set by reception of slave byte.

dsPIC33FJ06GS101/X02 and dsPIC33FJ16GSX02/X04

REGISTER 17-2: I2CxSTAT: I2Cx STATUS REGISTER (CONTINUED)

- bit 4 **P:** Stop bit
1 = Indicates that a Stop bit has been detected last
0 = Stop bit was not detected last
Hardware is set or clear when Start, Repeated Start or Stop is detected.
- bit 3 **S:** Start bit
1 = Indicates that a Start (or Repeated Start) bit has been detected last
0 = Start bit was not detected last
Hardware is set or clear when Start, Repeated Start or Stop is detected.
- bit 2 **R_W:** Read/Write Information bit (when operating as I²C slave)
1 = Read – indicates data transfer is output from slave
0 = Write – indicates data transfer is input to slave
Hardware is set or clear after reception of an I²C device address byte.
- bit 1 **RBF:** Receive Buffer Full Status bit
1 = Receive is complete, I2CxRCV is full
0 = Receive is not complete, I2CxRCV is empty
Hardware is set when I2CxRCV is written with a received byte. Hardware is clear when software reads I2CxRCV.
- bit 0 **TBF:** Transmit Buffer Full Status bit
1 = Transmit is in progress, I2CxTRN is full
0 = Transmit is complete, I2CxTRN is empty
Hardware is set when software writes to I2CxTRN. Hardware is clear at completion of data transmission.

dsPIC33FJ06GS101/X02 and dsPIC33FJ16GSX02/X04

REGISTER 17-3: I2CxMSK: I2Cx SLAVE MODE ADDRESS MASK REGISTER

U-0	U-0	U-0	U-0	U-0	U-0	R/W-0	R/W-0
—	—	—	—	—	—	AMSK<9:8>	
bit 15						bit 8	

R/W-0	R/W-0	R/W-0	R/W-0	R/W-0	R/W-0	R/W-0	R/W-0
AMSK<7:0>							
bit 7						bit 0	

Legend:

R = Readable bit	W = Writable bit	U = Unimplemented bit, read as '0'
-n = Value at POR	'1' = Bit is set	'0' = Bit is cleared x = Bit is unknown

bit 15-10 **Unimplemented:** Read as '0'

bit 9-0 **AMSK<9:0>:** Mask for Address bit x Select bits

1 = Enables masking for bit x of incoming message address; bit match is not required in this position

0 = Disables masking for bit x; bit match is required in this position

dsPIC33FJ06GS101/X02 and dsPIC33FJ16GSX02/X04

18.0 UNIVERSAL ASYNCHRONOUS RECEIVER TRANSMITTER (UART)

Note 1: This data sheet summarizes the features of the dsPIC33FJ06GS101/X02 and dsPIC33FJ16GSX02/X04 family of devices. It is not intended to be a comprehensive reference source. To complement the information in this data sheet, refer to “UART” (DS70188) in the “dsPIC33F/PIC24H Family Reference Manual”, which is available on the Microchip web site (www.microchip.com).

2: Some registers and associated bits described in this section may not be available on all devices. Refer to [Section 4.0 “Memory Organization”](#) in this data sheet for device-specific register and bit information.

The Universal Asynchronous Receiver Transmitter (UART) module is one of the serial I/O modules available in the dsPIC33FJ06GS101/X02 and dsPIC33FJ16GSX02/X04 device families. The UART is a full-duplex, asynchronous system that can communicate with peripheral devices, such as personal computers, LIN/J2602, RS-232 and RS-485 interfaces. The module also supports a hardware flow control option with the UxCTS and UxRTS pins and also includes an IrDA[®] encoder and decoder.

The primary features of the UART module are:

- Full-Duplex, 8-Bit or 9-Bit Data Transmission through the UxTX and UxRX Pins
- Even, Odd or No Parity Options (for 8-bit data)
- One or Two Stop bits
- Hardware Flow Control Option with \overline{UxCTS} and \overline{UxRTS} Pins
- Fully Integrated Baud Rate Generator with 16-Bit Prescaler
- Baud Rates Ranging from 12.5 Mbps to 38 bps at 50 MIPS
- 4-Deep First-In First-Out (FIFO) Transmit Data Buffer
- 4-Deep FIFO Receive Data Buffer
- Parity, Framing and Buffer Overrun Error Detection
- Support for 9-Bit mode with Address Detect (9th bit = 1)
- Transmit and Receive Interrupts
- A Separate Interrupt for all UART Error Conditions
- Loopback mode for Diagnostic Support
- Support for Sync and Break Characters
- Support for Automatic Baud Rate Detection
- IrDA Encoder and Decoder Logic
- 16x Baud Clock Output for IrDA[®] Support

A simplified block diagram of the UART module is shown in [Figure 1](#). The UART module consists of these key hardware elements:

- Baud Rate Generator
- Asynchronous Transmitter
- Asynchronous Receiver

FIGURE 1: UART1 SIMPLIFIED BLOCK DIAGRAM

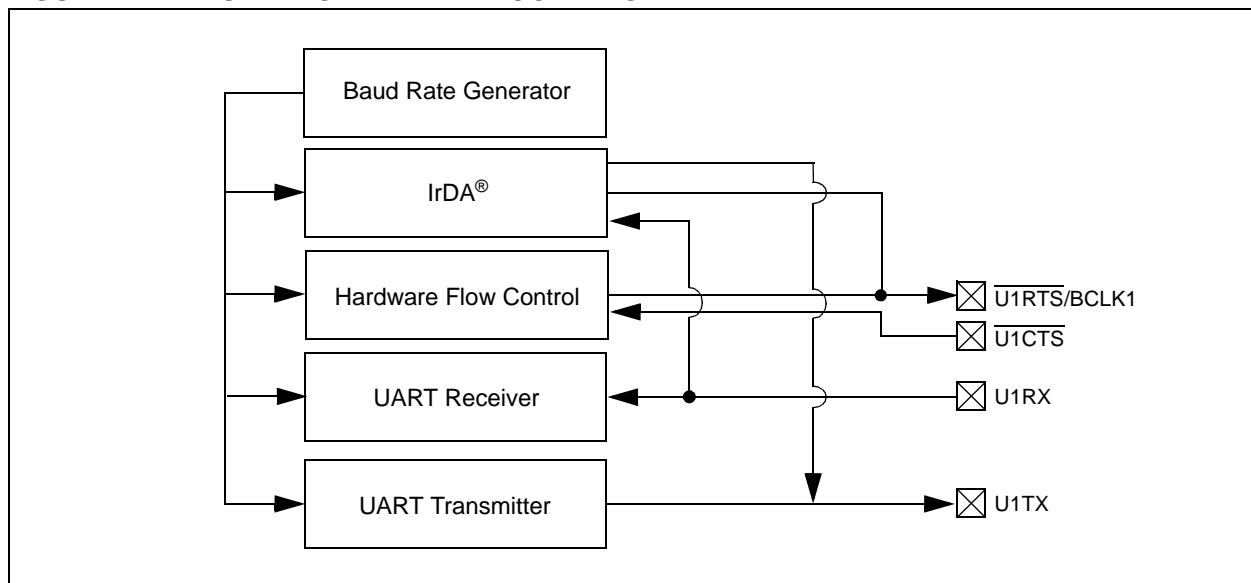

dsPIC33FJ06GS101/X02 and dsPIC33FJ16GSX02/X04

REGISTER 18-1: UxMODE: UARTx MODE REGISTER

R/W-0	U-0	R/W-0	R/W-0	R/W-0	U-0	R/W-0	R/W-0
UARTEN ⁽¹⁾	—	USIDL	IREN ⁽²⁾	RTSMD	—	UEN1	UEN0
bit 15						bit 8	

R/W-0, HC	R/W-0	R/W-0, HC	R/W-0	R/W-0	R/W-0	R/W-0	R/W-0
WAKE	LPBACK	ABAUD	URXINV	BRGH	PDSEL1	PDSEL0	STSEL
bit 7						bit 0	

Legend:	HC = Hardware Clearable bit		
R = Readable bit	W = Writable bit	U = Unimplemented bit, read as '0'	
-n = Value at POR	'1' = Bit is set	'0' = Bit is cleared	x = Bit is unknown

- bit 15 **UARTEN:** UARTx Enable bit⁽¹⁾
 1 = UARTx is enabled; all UARTx pins are controlled by UARTx as defined by UEN<1:0>
 0 = UARTx is disabled; all UARTx pins are controlled by port latches, UARTx power consumption is minimal
- bit 14 **Unimplemented:** Read as '0'
- bit 13 **USIDL:** UARTx Stop in Idle Mode bit
 1 = Discontinues module operation when device enters Idle mode
 0 = Continues module operation in Idle mode
- bit 12 **IREN:** IrDA[®] Encoder and Decoder Enable bit⁽²⁾
 1 = IrDA encoder and decoder are enabled
 0 = IrDA encoder and decoder are disabled
- bit 11 **RTSMD:** Mode Selection for UxRTS Pin bit
 1 = UxRTS pin is in Simplex mode
 0 = UxRTS pin is in Flow Control mode
- bit 10 **Unimplemented:** Read as '0'
- bit 9-8 **UEN<1:0>:** UARTx Enable bits
 11 = UxTX, UxRX and BCLK pins are enabled and used; UxCTS pin is controlled by port latches
 10 = UxTX, UxRX, UxCTS and UxRTS pins are enabled and used
 01 = UxTX, UxRX and UxRTS pins are enabled and used; UxCTS pin is controlled by port latches
 00 = UxTX and UxRX pins are enabled and used; UxCTS and UxRTS/BCLK pins are controlled by port latches
- bit 7 **WAKE:** Wake-up on Start bit Detect During Sleep Mode Enable bit
 1 = UARTx will continue to sample the UxRX pin; interrupt is generated on falling edge, bit is cleared in hardware on the following rising edge
 0 = No wake-up is enabled
- bit 6 **LPBACK:** UARTx Loopback Mode Select bit
 1 = Enables Loopback mode
 0 = Loopback mode is disabled
- bit 5 **ABAUD:** Auto-Baud Enable bit
 1 = Enable baud rate measurement on the next character – requires reception of a Sync field (55h) before other data; cleared in hardware upon completion
 0 = Baud rate measurement is disabled or has completed

Note 1: Refer to “UART” (DS70188) in the “dsPIC33F/PIC24H Family Reference Manual” for information on enabling the UART module for receive or transmit operation.

2: This feature is only available for the 16x BRG mode (BRGH = 0).

dsPIC33FJ06GS101/X02 and dsPIC33FJ16GSX02/X04

REGISTER 18-1: UxMODE: UARTx MODE REGISTER (CONTINUED)

- bit 4 **URXINV:** UARTx Receive Polarity Inversion bit
1 = UxRX Idle state is '0'
0 = UxRX Idle state is '1'
- bit 3 **BRGH:** High Baud Rate Enable bit
1 = BRG generates 4 clocks per bit period (4x baud clock, High-Speed mode)
0 = BRG generates 16 clocks per bit period (16x baud clock, Standard mode)
- bit 2-1 **PDSEL<1:0>:** Parity and Data Selection bits
11 = 9-bit data, no parity
10 = 8-bit data, odd parity
01 = 8-bit data, even parity
00 = 8-bit data, no parity
- bit 0 **STSEL:** Stop Bit Selection bit
1 = Two Stop bits
0 = One Stop bit

- Note 1:** Refer to “**UART**” (DS70188) in the “*dsPIC33F/PIC24H Family Reference Manual*” for information on enabling the UART module for receive or transmit operation.
- 2:** This feature is only available for the 16x BRG mode (BRGH = 0).

dsPIC33FJ06GS101/X02 and dsPIC33FJ16GSX02/X04

REGISTER 18-2: UxSTA: UARTx STATUS AND CONTROL REGISTER

R/W-0	R/W-0	R/W-0	U-0	R/W-0, HC	R/W-0	R-0	R-1
UTXISEL1	UTXINV	UTXISEL0	—	UTXBRK	UTXEN ⁽¹⁾	UTXBF	TRMT
bit 15						bit 8	

R/W-0	R/W-0	R/W-0	R-1	R-0	R-0	R/C-0	R-0
URXISEL1	URXISEL0	ADDEN	RIDLE	PERR	FERR	OERR	URXDA
bit 7						bit 0	

Legend:	HC = Hardware Clearable bit	C = Clearable bit
R = Readable bit	W = Writable bit	U = Unimplemented bit, read as '0'
-n = Value at POR	'1' = Bit is set	'0' = Bit is cleared
		x = Bit is unknown

- bit 15,13 **UTXISEL<1:0>**: UARTx Transmission Interrupt Mode Selection bits
 11 = Reserved; do not use
 10 = Interrupt when a character is transferred to the Transmit Shift Register (TSR), and as a result, the transmit buffer becomes empty
 01 = Interrupt when the last character is shifted out of the Transmit Shift Register; all transmit operations are completed
 00 = Interrupt when a character is transferred to the Transmit Shift Register (this implies there is at least one character open in the transmit buffer)
- bit 14 **UTXINV**: UARTx Transmit Polarity Inversion bit
 If IREN = 0:
 1 = UxTX Idle state is '0'
 0 = UxTX Idle state is '1'
 If IREN = 1:
 1 = IrDA[®] encoded UxTX Idle state is '1'
 0 = IrDA encoded UxTX Idle state is '0'
- bit 12 **Unimplemented**: Read as '0'
- bit 11 **UTXBRK**: UARTx Transmit Break bit
 1 = Sends Sync Break on next transmission – Start bit, followed by twelve '0' bits, followed by Stop bit; cleared by hardware upon completion
 0 = Sync Break transmission is disabled or has completed
- bit 10 **UTXEN**: UARTx Transmit Enable bit⁽¹⁾
 1 = Transmit is enabled, UxTX pin is controlled by UARTx
 0 = Transmit is disabled, any pending transmission is aborted and buffer is reset; UxTX pin is controlled by port
- bit 9 **UTXBF**: UARTx Transmit Buffer Full Status bit (read-only)
 1 = Transmit buffer is full
 0 = Transmit buffer is not full; at least one more character can be written
- bit 8 **TRMT**: Transmit Shift Register Empty bit (read-only)
 1 = Transmit Shift Register is empty and transmit buffer is empty (the last transmission has completed)
 0 = Transmit Shift Register is not empty, a transmission is in progress or queued
- bit 7-6 **URXISEL<1:0>**: UARTx Receive Interrupt Mode Selection bits
 11 = Interrupt is set on UxRSR transfer, making the receive buffer full (i.e., has 4 data characters)
 10 = Interrupt is set on UxRSR transfer, making the receive buffer 3/4 full (i.e., has 3 data characters)
 0x = Interrupt is set when any character is received and transferred from the UxRSR to the receive buffer; receive buffer has one or more characters

Note 1: Refer to “UART” (DS70188) in the “dsPIC33F/PIC24H Family Reference Manual” for information on enabling the UART module for transmit operation.

dsPIC33FJ06GS101/X02 and dsPIC33FJ16GSX02/X04

REGISTER 18-2: UxSTA: UARTx STATUS AND CONTROL REGISTER (CONTINUED)

- bit 5 **ADDEN:** Address Character Detect bit (bit 8 of received data = 1)
1 = Address Detect mode is enable; if 9-bit mode is not selected, this does not take effect
0 = Address Detect mode is disabled
- bit 4 **RIDLE:** Receiver Idle bit (read-only)
1 = Receiver is Idle
0 = Receiver is active
- bit 3 **PERR:** Parity Error Status bit (read-only)
1 = Parity error has been detected for the current character (character at the top of the receive FIFO)
0 = Parity error has not been detected
- bit 2 **FERR:** Framing Error Status bit (read-only)
1 = Framing error has been detected for the current character (character at the top of the receive FIFO)
0 = Framing error has not been detected
- bit 1 **OERR:** Receive Buffer Overrun Error Status bit (clear/read-only)
1 = Receive buffer has overflowed
0 = Receive buffer has not overflowed; clearing a previously set OERR bit (1 → 0 transition) will reset the receiver buffer and the UxRSR to the empty state
- bit 0 **URXDA:** UARTx Receive Buffer Data Available bit (read-only)
1 = Receive buffer has data, at least one more character can be read
0 = Receive buffer is empty

Note 1: Refer to “**UART**” (DS70188) in the “*dsPIC33F/PIC24H Family Reference Manual*” for information on enabling the UART module for transmit operation.

dsPIC33FJ06GS101/X02 and dsPIC33FJ16GSX02/X04

NOTES:

19.0 HIGH-SPEED 10-BIT ANALOG-TO-DIGITAL CONVERTER (ADC)

Note 1: This data sheet summarizes the features of the dsPIC33FJ06GS101/X02 and dsPIC33FJ16GSX02/X04 families of devices. It is not intended to be a comprehensive reference source. To complement the information in this data sheet, refer to “**High-Speed 10-Bit Analog-to-Digital Converter (ADC)**” (DS70000321) in the “*dsPIC33/PIC24 Family Reference Manual*”, which is available on the Microchip web site (www.microchip.com).

2: Some registers and associated bits described in this section may not be available on all devices. Refer to **Section 4.0 “Memory Organization”** in this data sheet for device-specific register and bit information.

dsPIC33FJ06GS101/X02 and dsPIC33FJ16GSX02/X04 devices provide high-speed, successive approximation Analog-to-Digital conversions to support applications, such as AC/DC and DC/DC power converters.

19.1 Features Overview

The ADC module comprises the following features:

- 10-bit resolution
- Unipolar inputs
- Up to two Successive Approximation Registers (SARs)
- Up to 12 external input channels
- Up to two internal analog inputs
- Dedicated result register for each analog input
- ± 1 LSB accuracy at 3.3V
- Single supply operation
- 4 Msps conversion rate at 3.3V (devices with two SARs)
- 2 Msps conversion rate at 3.3V (devices with one SAR)
- Low-power CMOS technology

19.2 Module Description

This ADC module is designed for applications that require low latency between the request for conversion and the resultant output data. Typical applications include:

- AC/DC power supplies
- DC/DC Converters
- Power Factor Correction (PFC)

This ADC works with the high-speed PWM module in power control applications that require high-frequency control loops. This module can sample and convert two analog inputs in a 0.5 microsecond when two SARs are used. This small conversion delay reduces the “phase lag” between measurement and control system response.

Up to five inputs may be sampled at a time (four inputs from the dedicated Sample-and-Hold circuits and one from the shared Sample-and-Hold circuit). If multiple inputs request conversion, the ADC will convert them in a sequential manner, starting with the lowest order input.

This ADC design provides each pair of analog inputs (AN1, AN0), (AN3, AN2),..., the ability to specify its own trigger source out of a maximum of sixteen different trigger sources. This capability allows this ADC to sample and convert analog inputs that are associated with PWM generators operating on Independent Time Bases (ITBs).

The user application typically requires synchronization between analog data sampling and PWM output to the application circuit. The very high-speed operation of this ADC module allows “data on demand”.

In addition, several hardware features have been added to the peripheral interface to improve real-time performance in a typical DSP-based application.

- Result alignment options
- Automated sampling
- External conversion start control
- Two internal inputs to monitor the INTREF internal reference and the EXTREF input signal

19.3 Module Functionality

The high-speed, 10-bit ADC module is designed to support power conversion applications when used with the high-speed PWM module. The ADC may have one or two SAR modules, depending on the device variant. If two SARs are present on a device, two conversions can be processed at a time, yielding 4 Msps conversion rate. If only one SAR is present on a device, only one conversion can be processed at a time, yielding 2 Msps conversion rate. The high-speed 10-bit ADC produces two 10-bit conversion results in a 0.5 microsecond.

The ADC module supports up to 12 external analog inputs and two internal analog inputs. To monitor reference voltage, two internal inputs, AN12 and AN13, are connected to the EXTREF and INTREF voltages, respectively.

The analog reference voltage is defined as the device supply voltage (V_{DD}/V_{SS}).

Block diagrams of the ADC module are shown in [Figure 19-1](#) through [Figure 19-6](#).

dsPIC33FJ06GS101/X02 and dsPIC33FJ16GSX02/X04

FIGURE 19-1: ADC BLOCK DIAGRAM FOR dsPIC33FJ06GS101 DEVICES WITH ONE SAR



dsPIC33FJ06GS101/X02 and dsPIC33FJ16GSX02/X04

FIGURE 19-2: ADC BLOCK DIAGRAM FOR dsPIC33FJ06GS102 DEVICES WITH ONE SAR



dsPIC33FJ06GS101/X02 and dsPIC33FJ16GSX02/X04

FIGURE 19-3: ADC BLOCK DIAGRAM FOR dsPIC33FJ06GS202 DEVICES WITH ONE SAR



dsPIC33FJ06GS101/X02 and dsPIC33FJ16GSX02/X04

FIGURE 19-4: ADC BLOCK DIAGRAM FOR dsPIC33FJ16GS402/404 DEVICES WITH ONE SAR



dsPIC33FJ06GS101/X02 and dsPIC33FJ16GSX02/X04

FIGURE 19-5: ADC BLOCK DIAGRAM FOR dsPIC33FJ16GS502 DEVICES WITH TWO SARs



dsPIC33FJ06GS101/X02 and dsPIC33FJ16GSX02/X04

FIGURE 19-6: ADC BLOCK DIAGRAM FOR dsPIC33FJ16GS504 DEVICES WITH TWO SARs



dsPIC33FJ06GS101/X02 and dsPIC33FJ16GSX02/X04

19.4 ADC Control Registers

The ADC module uses the following control and status registers:

- [ADCON: Analog-to-Digital Control Register](#)
- [ADSTAT: Analog-to-Digital Status Register](#)
- [ADBASE: Analog-to-Digital Base Register\(1,2\)](#)
- [ADPCFG: Analog-to-Digital Port Configuration Register](#)
- [ADCPC0: Analog-to-Digital Convert Pair Control Register 0](#)
- [ADCPC1: Analog-to-Digital Convert Pair Control Register 1](#)
- [ADCPC2: Analog-to-Digital Convert Pair Control Register 2\(1\)](#)
- [ADCPC3: Analog-to-Digital Convert Pair Control Register 3\(1\)](#)

The ADCON register controls the operation of the ADC module. The ADSTAT register displays the status of the conversion processes. The ADPCFG registers configure the port pins as analog inputs or as digital I/O. The ADCPCx registers control the triggering of the ADC conversions. See [Register 19-1](#) through [Register 19-8](#) for detailed bit configurations.

<p>Note: A unique feature of the ADC module is its ability to sample inputs in an asynchronous manner. Individual Sample-and-Hold circuits can be triggered independently of each other.</p>

dsPIC33FJ06GS101/X02 and dsPIC33FJ16GSX02/X04

REGISTER 19-1: ADCON: ANALOG-TO-DIGITAL CONTROL REGISTER

R/W-0	U-0	R/W-0	R/W-0	U-0	R/W-0	U-0	R/W-0
ADON	—	ADSIDL	SLOWCLK ⁽¹⁾	—	GSWTRG	—	FORM ⁽¹⁾
bit 15							bit 8

R/W-0	R/W-0	R/W-0	R/W-0	U-0	R/W-0	R/W-1	R/W-1
EIE ⁽¹⁾	ORDER ^(1,2)	SEQSAMP ^(1,2)	ASYNCAMP ⁽¹⁾	—	ADCS2 ⁽¹⁾	ADCS1 ⁽¹⁾	ADCS0 ⁽¹⁾
bit 7							bit 0

Legend:

R = Readable bit	W = Writable bit	U = Unimplemented bit, read as '0'
-n = Value at POR	'1' = Bit is set	'0' = Bit is cleared
		x = Bit is unknown

- bit 15 **ADON:** Analog-to-Digital Operating Mode bit
1 = Analog-to-Digital Converter (ADC) module is operating
0 = ADC Converter is off
- bit 14 **Unimplemented:** Read as '0'
- bit 13 **ADSIDL:** ADC Stop in Idle Mode bit
1 = Discontinues module operation when device enters Idle mode
0 = Continues module operation in Idle mode
- bit 12 **SLOWCLK:** Enable The Slow Clock Divider bit⁽¹⁾
1 = ADC is clocked by the auxiliary PLL (ACLK)
0 = ADC is clock by the primary PLL (Fvco)
- bit 11 **Unimplemented:** Read as '0'
- bit 10 **GSWTRG:** Global Software Trigger bit
When this bit is set by the user, it will trigger conversions if selected by the TRGSRC<4:0> bits in the ADCPCx registers. This bit must be cleared by the user prior to initiating another global trigger (i.e., this bit is not auto-clearing).
- bit 9 **Unimplemented:** Read as '0'
- bit 8 **FORM:** Data Output Format bit⁽¹⁾
1 = Fractional (DOUT = dddd dddd dd00 0000)
0 = Integer (DOUT = 0000 00dd dddd dddd)
- bit 7 **EIE:** Early Interrupt Enable bit⁽¹⁾
1 = Interrupt is generated after first conversion is completed
0 = Interrupt is generated after second conversion is completed
- bit 6 **ORDER:** Conversion Order bit^(1,2)
1 = Odd numbered analog input is converted first, followed by conversion of even numbered input
0 = Even numbered analog input is converted first, followed by conversion of odd numbered input
- bit 5 **SEQSAMP:** Sequential Sample Enable bit^(1,2)
1 = Shared Sample-and-Hold (S&H) circuit is sampled at the start of the second conversion if ORDER = 0. If ORDER = 1, then the shared S&H is sampled at the start of the first conversion.
0 = Shared S&H is sampled at the same time the dedicated S&H is sampled if the shared S&H is not currently busy with an existing conversion process. If the shared S&H is busy at the time the dedicated S&H is sampled, then the shared S&H will sample at the start of the new conversion cycle.

Note 1: These control bits can only be changed while ADC is disabled (ADON = 0).
Note 2: These bits are only available on devices with one SAR.

dsPIC33FJ06GS101/X02 and dsPIC33FJ16GSX02/X04

REGISTER 19-1: ADCON: ANALOG-TO-DIGITAL CONTROL REGISTER (CONTINUED)

- bit 4 **ASYNCNSAMP:** Asynchronous Dedicated S&H Sampling Enable bit⁽¹⁾
1 = The dedicated S&H is constantly sampling and then terminates sampling as soon as the trigger pulse is detected
0 = The dedicated S&H starts sampling when the trigger event is detected and completes the sampling process in two ADC clock cycles
- bit 3 **Unimplemented:** Read as '0'
- bit 2-0 **ADCS<2:0>:** Analog-to-Digital Conversion Clock Divider Select bits⁽¹⁾
111 = FADC/8
110 = FADC/7
101 = FADC/6
100 = FADC/5
011 = FADC/4 (default)
010 = FADC/3
001 = FADC/2
000 = FADC/1

- Note 1:** These control bits can only be changed while ADC is disabled (ADON = 0).
2: These bits are only available on devices with one SAR.

dsPIC33FJ06GS101/X02 and dsPIC33FJ16GSX02/X04

REGISTER 19-2: ADSTAT: ANALOG-TO-DIGITAL STATUS REGISTER

U-0	U-0	U-0	U-0	U-0	U-0	U-0	U-0
—	—	—	—	—	—	—	—
bit 15						bit 8	

U-0	R/C-0, HS	R/C-0, HS	R/C-0, HS	R/C-0, HS	R/C-0, HS	R/C-0, HS	R/C-0, HS
—	P6RDY	P5RDY	P4RDY	P3RDY	P2RDY	P1RDY	P0RDY
bit 7						bit 0	

Legend:	C = Clearable bit	HS = Hardware Settable bit
R = Readable bit	W = Writable bit	U = Unimplemented bit, read as '0'
-n = Value at POR	'1' = Bit is set	'0' = Bit is cleared x = Bit is unknown

- bit 15-7 **Unimplemented:** Read as '0'
- bit 6 **P6RDY:** Conversion Data for Pair 6 Ready bit
Bit is set when data is ready in buffer, cleared when a '0' is written to this bit.
- bit 5 **P5RDY:** Conversion Data for Pair 5 Ready bit
Bit is set when data is ready in buffer, cleared when a '0' is written to this bit.
- bit 4 **P4RDY:** Conversion Data for Pair 4 Ready bit
Bit is set when data is ready in buffer, cleared when a '0' is written to this bit.
- bit 3 **P3RDY:** Conversion Data for Pair 3 Ready bit
Bit is set when data is ready in buffer, cleared when a '0' is written to this bit.
- bit 2 **P2RDY:** Conversion Data for Pair 2 Ready bit
Bit is set when data is ready in buffer, cleared when a '0' is written to this bit.
- bit 1 **P1RDY:** Conversion Data for Pair 1 Ready bit
Bit is set when data is ready in buffer, cleared when a '0' is written to this bit.
- bit 0 **P0RDY:** Conversion Data for Pair 0 Ready bit
Bit is set when data is ready in buffer, cleared when a '0' is written to this bit.

dsPIC33FJ06GS101/X02 and dsPIC33FJ16GSX02/X04

REGISTER 19-3: ADBASE: ANALOG-TO-DIGITAL BASE REGISTER^(1,2)

R/W-0	R/W-0	R/W-0	R/W-0	R/W-0	R/W-0	R/W-0	R/W-0
ADBASE<15:8>							
bit 15							bit 8

R/W-0	R/W-0	R/W-0	R/W-0	R/W-0	R/W-0	R/W-0	U-0
ADBASE<7:1>							—
bit 7							bit 0

Legend:

R = Readable bit W = Writable bit U = Unimplemented bit, read as '0'
 -n = Value at POR '1' = Bit is set '0' = Bit is cleared x = Bit is unknown

bit 15-1 **ADBASE<15:1>**: Analog-to-Digital Base bits
 This register contains the base address of the user's ADC Interrupt Service Routine jump table. This register, when read, contains the sum of the ADBASE register contents and the encoded value of the PxRDY status bits.
 The encoder logic provides the bit number of the highest priority PxRDY bits, where P0RDY is the highest priority and P6RDY is the lowest priority.

bit 0 **Unimplemented**: Read as '0'

- Note 1:** The encoding results are shifted left two bits, so bits 1-0 of the result are always zero.
Note 2: As an alternative to using the ADBASE register, the ADCP0-6 ADC Pair Conversion Complete interrupts can be used to invoke A to D conversion completion routines for individual ADC input pairs.

REGISTER 19-4: ADPCFG: ANALOG-TO-DIGITAL PORT CONFIGURATION REGISTER

U-0	U-0	U-0	U-0	R/W-0	R/W-0	R/W-0	R/W-0
—	—	—	—	PCFG<11:8> ⁽¹⁾			
bit 15							bit 8

R/W-0	R/W-0	R/W-0	R/W-0	R/W-0	R/W-0	R/W-0	R/W-0
PCFG<7:0> ⁽¹⁾							
bit 7							bit 0

Legend:

R = Readable bit W = Writable bit U = Unimplemented bit, read as '0'
 -n = Value at POR '1' = Bit is set '0' = Bit is cleared x = Bit is unknown

bit 15-12 **Unimplemented**: Read as '0'
bit 11-0 **PCFG<11:0>**: Analog-to-Digital Port Configuration Control bits⁽¹⁾
 1 = Port pin in Digital mode; port read input is enabled, Analog-to-Digital input multiplexer is connected to AVSS
 0 = Port pin in Analog mode; port read input is disabled, Analog-to-Digital samples the pin voltage

- Note 1:** Not all PCFGx bits are available on all devices. See [Figure 19-1](#) through [Figure 19-6](#) for the available analog pins (PCFGx = ANx, where x = 0-11).

dsPIC33FJ06GS101/X02 and dsPIC33FJ16GSX02/X04

REGISTER 19-5: ADCPC0: ANALOG-TO-DIGITAL CONVERT PAIR CONTROL REGISTER 0

R/W-0	R/W-0	R/W-0	R/W-0	R/W-0	R/W-0	R/W-0	R/W-0
IRQEN1	PEND1	SWTRG1	TRGSRC14	TRGSRC13	TRGSRC12	TRGSRC11	TRGSRC10
bit 15							bit 8

R/W-0	R/W-0	R/W-0	R/W-0	R/W-0	R/W-0	R/W-0	R/W-0
IRQEN0	PEND0	SWTRG0	TRGSRC04	TRGSRC03	TRGSRC02	TRGSRC01	TRGSRC00
bit 7							bit 0

Legend:

R = Readable bit	W = Writable bit	U = Unimplemented bit, read as '0'
-n = Value at POR	'1' = Bit is set	'0' = Bit is cleared x = Bit is unknown

- bit 15 **IRQEN1:** Interrupt Request Enable 1 bit
 1 = Enables IRQ generation when requested conversion of Channels AN3 and AN2 is completed
 0 = IRQ is not generated
- bit 14 **PEND1:** Pending Conversion Status 1 bit
 1 = Conversion of Channels AN3 and AN2 is pending; set when selected trigger is asserted
 0 = Conversion is complete
- bit 13 **SWTRG1:** Software Trigger 1 bit
 1 = Starts conversion of AN3 and AN2 (if selected by the TRGSRCx bits)⁽¹⁾
 This bit is automatically cleared by hardware when the PEND1 bit is set.
 0 = Conversion has not started

Note 1: The trigger source must be set as a global software trigger prior to setting this bit to '1'. If other conversions are in progress, then the conversion will be performed when the conversion resources are available.

dsPIC33FJ06GS101/X02 and dsPIC33FJ16GSX02/X04

REGISTER 19-5: ADCPC0: ANALOG-TO-DIGITAL CONVERT PAIR CONTROL REGISTER 0 (CONTINUED)

- bit 12-8 **TRGSRC1<4:0>**: Trigger 1 Source Selection bits
Selects trigger source for conversion of Analog Channels AN3 and AN2.
11111 = Timer2 period match
•
•
•
11011 = Reserved
11010 = PWM Generator 4 current-limit ADC trigger
11001 = PWM Generator 3 current-limit ADC trigger
11000 = PWM Generator 2 current-limit ADC trigger
10111 = PWM Generator 1 current-limit ADC trigger
10110 = Reserved
•
•
•
10010 = Reserved
10001 = PWM Generator 4 secondary trigger is selected
10000 = PWM Generator 3 secondary trigger is selected
01111 = PWM Generator 2 secondary trigger is selected
01110 = PWM Generator 1 secondary trigger is selected
01101 = Reserved
01100 = Timer1 period match
•
•
•
01000 = Reserved
00111 = PWM Generator 4 primary trigger is selected
00110 = PWM Generator 3 primary trigger is selected
00101 = PWM Generator 2 primary trigger is selected
00100 = PWM Generator 1 primary trigger is selected
00011 = PWM Special Event Trigger is selected
00010 = Global software trigger is selected
00001 = Individual software trigger is selected
00000 = No conversion is enabled
- bit 7 **IRQEN0**: Interrupt Request Enable 0 bit
1 = Enables IRQ generation when requested conversion of Channels AN1 and AN0 is completed
0 = IRQ is not generated
- bit 6 **PEND0**: Pending Conversion Status 0 bit
1 = Conversion of Channels AN1 and AN0 is pending; set when selected trigger is asserted
0 = Conversion is complete
- bit 5 **SWTRG0**: Software Trigger 0 bit
1 = Starts conversion of AN1 and AN0 (if selected by the TRGSRCx bits)⁽¹⁾
 This bit is automatically cleared by hardware when the PEND0 bit is set.
0 = Conversion has not started

Note 1: The trigger source must be set as a global software trigger prior to setting this bit to '1'. If other conversions are in progress, then the conversion will be performed when the conversion resources are available.

dsPIC33FJ06GS101/X02 and dsPIC33FJ16GSX02/X04

REGISTER 19-5: ADCPC0: ANALOG-TO-DIGITAL CONVERT PAIR CONTROL REGISTER 0 (CONTINUED)

bit 4-0 **TRGSR0<4:0>**: Trigger 0 Source Selection bits
Selects trigger source for conversion of Analog Channels AN1 and AN0.
11111 = Timer2 period match
•
•
•
11011 = Reserved
11010 = PWM Generator 4 current-limit ADC trigger
11001 = PWM Generator 3 current-limit ADC trigger
11000 = PWM Generator 2 current-limit ADC trigger
10111 = PWM Generator 1 current-limit ADC trigger
10110 = Reserved
•
•
•
10010 = Reserved
10001 = PWM Generator 4 secondary trigger is selected
10000 = PWM Generator 3 secondary trigger is selected
01111 = PWM Generator 2 secondary trigger is selected
01110 = PWM Generator 1 secondary trigger is selected
01101 = Reserved
01100 = Timer1 period match
•
•
•
01000 = Reserved
00111 = PWM Generator 4 primary trigger is selected
00110 = PWM Generator 3 primary trigger is selected
00101 = PWM Generator 2 primary trigger is selected
00100 = PWM Generator 1 primary trigger is selected
00011 = PWM Special Event Trigger is selected
00010 = Global software trigger is selected
00001 = Individual software trigger is selected
00000 = No conversion is enabled

Note 1: The trigger source must be set as a global software trigger prior to setting this bit to '1'. If other conversions are in progress, then the conversion will be performed when the conversion resources are available.

dsPIC33FJ06GS101/X02 and dsPIC33FJ16GSX02/X04

REGISTER 19-6: ADCPC1: ANALOG-TO-DIGITAL CONVERT PAIR CONTROL REGISTER 1

R/W-0	R/W-0	R/W-0	R/W-0	R/W-0	R/W-0	R/W-0	R/W-0
IRQEN3 ⁽¹⁾	PEND3 ⁽¹⁾	SWTRG3 ⁽¹⁾	TRGSRC34 ⁽¹⁾	TRGSRC33 ⁽¹⁾	TRGSRC32 ⁽¹⁾	TRGSRC31 ⁽¹⁾	TRGSRC30 ⁽¹⁾
bit 15							bit 8

R/W-0	R/W-0	R/W-0	R/W-0	R/W-0	R/W-0	R/W-0	R/W-0
IRQEN2 ⁽²⁾	PEND2 ⁽²⁾	SWTRG2 ⁽²⁾	TRGSRC24 ⁽²⁾	TRGSRC23 ⁽²⁾	TRGSRC22 ⁽²⁾	TRGSRC21 ⁽²⁾	TRGSRC20 ⁽²⁾
bit 7							bit 0

Legend:

R = Readable bit	W = Writable bit	U = Unimplemented bit, read as '0'
-n = Value at POR	'1' = Bit is set	'0' = Bit is cleared x = Bit is unknown

- bit 15 **IRQEN3:** Interrupt Request Enable 3 bit⁽¹⁾
 1 = Enables IRQ generation when requested conversion of Channels AN7 and AN6 is completed
 0 = IRQ is not generated
- bit 14 **PEND3:** Pending Conversion Status 3 bit⁽¹⁾
 1 = Conversion of Channels AN7 and AN6 is pending; set when selected trigger is asserted
 0 = Conversion is complete
- bit 13 **SWTRG3:** Software Trigger 3 bit⁽¹⁾
 1 = Starts conversion of AN7 and AN6 (if selected by the TRGSRCx bits)⁽³⁾
 This bit is automatically cleared by hardware when the PEND3 bit is set.
 0 = Conversion has not started

- Note 1:** These bits are available in the dsPIC33FJ16GS402/404, dsPIC33FJ16GS504, dsPIC33FJ16GS502 and dsPIC33FJ06GS101 devices only.
- 2:** These bits are available in the dsPIC33FJ16GS502, dsPIC33FJ16GS504, dsPIC33FJ06GS102, dsPIC33FJ06GS202 and dsPIC33FJ16GS402/404 devices only.
- 3:** The trigger source must be set as a global software trigger prior to setting this bit to '1'. If other conversions are in progress, then the conversion will be performed when the conversion resources are available.

dsPIC33FJ06GS101/X02 and dsPIC33FJ16GSX02/X04

REGISTER 19-6: ADCPC1: ANALOG-TO-DIGITAL CONVERT PAIR CONTROL REGISTER 1 (CONTINUED)

- bit 12-8 **TRGSRC3<4:0>**: Trigger 3 Source Selection bits⁽¹⁾
Selects trigger source for conversion of Analog Channels AN7 and AN6.
11111 = Timer2 period match
•
•
•
11011 = Reserved
11010 = PWM Generator 4 current-limit ADC trigger
11001 = PWM Generator 3 current-limit ADC trigger
11000 = PWM Generator 2 current-limit ADC trigger
10111 = PWM Generator 1 current-limit ADC trigger
10110 = Reserved
•
•
•
10010 = Reserved
10001 = PWM Generator 4 secondary trigger is selected
10000 = PWM Generator 3 secondary trigger is selected
01111 = PWM Generator 2 secondary trigger is selected
01110 = PWM Generator 1 secondary trigger is selected
01101 = Reserved
01100 = Timer1 period match
•
•
•
01000 = Reserved
00111 = PWM Generator 4 primary trigger is selected
00110 = PWM Generator 3 primary trigger is selected
00101 = PWM Generator 2 primary trigger is selected
00100 = PWM Generator 1 primary trigger is selected
00011 = PWM Special Event Trigger is selected
00010 = Global software trigger is selected
00001 = Individual software trigger is selected
00000 = No conversion is enabled
- bit 7 **IRQEN2**: Interrupt Request Enable 2 bit⁽²⁾
1 = Enables IRQ generation when requested conversion of Channels AN5 and AN4 is completed
0 = IRQ is not generated
- bit 6 **PEND2**: Pending Conversion Status 2 bit⁽²⁾
1 = Conversion of Channels AN5 and AN4 is pending; set when selected trigger is asserted
0 = Conversion is complete
- bit 5 **SWTRG2**: Software Trigger 2 bit⁽²⁾
1 = Starts conversion of AN5 and AN4 (if selected by the TRGSRCx bits)⁽³⁾
This bit is automatically cleared by hardware when the PEND2 bit is set.
0 = Conversion has not started

Note 1: These bits are available in the dsPIC33FJ16GS402/404, dsPIC33FJ16GS504, dsPIC33FJ16GS502 and dsPIC33FJ06GS101 devices only.

2: These bits are available in the dsPIC33FJ16GS502, dsPIC33FJ16GS504, dsPIC33FJ06GS102, dsPIC33FJ06GS202 and dsPIC33FJ16GS402/404 devices only.

3: The trigger source must be set as a global software trigger prior to setting this bit to '1'. If other conversions are in progress, then the conversion will be performed when the conversion resources are available.

dsPIC33FJ06GS101/X02 and dsPIC33FJ16GSX02/X04

REGISTER 19-6: ADCPC1: ANALOG-TO-DIGITAL CONVERT PAIR CONTROL REGISTER 1 (CONTINUED)

bit 4-0 **TRGSRC2<4:0>**: Trigger 2 Source Selection bits⁽²⁾
Selects trigger source for conversion of Analog Channels AN5 and AN4.
11111 = Timer2 period match
•
•
•
11011 = Reserved
11010 = PWM Generator 4 current-limit ADC trigger
11001 = PWM Generator 3 current-limit ADC trigger
11000 = PWM Generator 2 current-limit ADC trigger
10111 = PWM Generator 1 current-limit ADC trigger
10110 = Reserved
•
•
•
10010 = Reserved
10001 = PWM Generator 4 secondary trigger is selected
10000 = PWM Generator 3 secondary trigger is selected
01111 = PWM Generator 2 secondary trigger is selected
01110 = PWM Generator 1 secondary trigger is selected
01101 = Reserved
01100 = Timer1 period match
•
•
•
01000 = Reserved
00111 = PWM Generator 4 primary trigger is selected
00110 = PWM Generator 3 primary trigger is selected
00101 = PWM Generator 2 primary trigger is selected
00100 = PWM Generator 1 primary trigger is selected
00011 = PWM Special Event Trigger is selected
00010 = Global software trigger is selected
00001 = Individual software trigger is selected
00000 = No conversion is enabled

- Note 1:** These bits are available in the dsPIC33FJ16GS402/404, dsPIC33FJ16GS504, dsPIC33FJ16GS502 and dsPIC33FJ06GS101 devices only.
- 2:** These bits are available in the dsPIC33FJ16GS502, dsPIC33FJ16GS504, dsPIC33FJ06GS102, dsPIC33FJ06GS202 and dsPIC33FJ16GS402/404 devices only.
- 3:** The trigger source must be set as a global software trigger prior to setting this bit to '1'. If other conversions are in progress, then the conversion will be performed when the conversion resources are available.

dsPIC33FJ06GS101/X02 and dsPIC33FJ16GSX02/X04

REGISTER 19-7: ADCPC2: ANALOG-TO-DIGITAL CONVERT PAIR CONTROL REGISTER 2⁽¹⁾

R/W-0	R/W-0	R/W-0	R/W-0	R/W-0	R/W-0	R/W-0	R/W-0
IRQEN5	PEND5	SWTRG5	TRGSRC54	TRGSRC53	TRGSRC52	TRGSRC51	TRGSRC50
bit 15							bit 8

R/W-0	R/W-0	R/W-0	R/W-0	R/W-0	R/W-0	R/W-0	R/W-0
IRQEN4	PEND4	SWTRG4	TRGSRC44	TRGSRC43	TRGSRC42	TRGSRC41	TRGSRC40
bit 7							bit 0

Legend:

R = Readable bit	W = Writable bit	U = Unimplemented bit, read as '0'
-n = Value at POR	'1' = Bit is set	'0' = Bit is cleared
		x = Bit is unknown

- bit 15 **IRQEN5:** Interrupt Request Enable 5 bit
 1 = Enables IRQ generation when requested conversion of Channels AN11 and AN10 is completed
 0 = IRQ is not generated
- bit 14 **PEND5:** Pending Conversion Status 5 bit
 1 = Conversion of Channels AN11 and AN10 is pending; set when selected trigger is asserted
 0 = Conversion is complete
- bit 13 **SWTRG5:** Software Trigger 5 bit
 1 = Starts conversion of AN11 and AN10 (if selected by the TRGSRCx bits)⁽²⁾
 This bit is automatically cleared by hardware when the PEND5 bit is set.
 0 = Conversion has not started

Note 1: This register is only implemented in the dsPIC33FJ16GS504 devices.

- 2:** The trigger source must be set as a global software trigger prior to setting this bit to '1'. If other conversions are in progress, then the conversion will be performed when the conversion resources are available.

dsPIC33FJ06GS101/X02 and dsPIC33FJ16GSX02/X04

REGISTER 19-7: ADCPC2: ANALOG-TO-DIGITAL CONVERT PAIR CONTROL REGISTER 2⁽¹⁾ (CONTINUED)

- bit 12-8 **TRGSRC5<4:0>**: Trigger 5 Source Selection bits
Selects trigger source for conversion of Analog Channels AN11 and AN10.
11111 = Timer2 period match
•
•
•
11011 = Reserved
11010 = PWM Generator 4 current-limit ADC trigger
11001 = PWM Generator 3 current-limit ADC trigger
11000 = PWM Generator 2 current-limit ADC trigger
10111 = PWM Generator 1 current-limit ADC trigger
10110 = Reserved
•
•
•
10010 = Reserved
10001 = PWM Generator 4 secondary trigger is selected
10000 = PWM Generator 3 secondary trigger is selected
01111 = PWM Generator 2 secondary trigger is selected
01110 = PWM Generator 1 secondary trigger is selected
01101 = Reserved
01100 = Timer1 period match
•
•
•
01000 = Reserved
00111 = PWM Generator 4 primary trigger is selected
00110 = PWM Generator 3 primary trigger is selected
00101 = PWM Generator 2 primary trigger is selected
00100 = PWM Generator 1 primary trigger is selected
00011 = PWM Special Event Trigger is selected
00010 = Global software trigger is selected
00001 = Individual software trigger is selected
00000 = No conversion is enabled
- bit 7 **IRQEN4**: Interrupt Request Enable 4 bit
1 = Enables IRQ generation when requested conversion of Channels AN9 and AN8 is completed
0 = IRQ is not generated
- bit 6 **PEND4**: Pending Conversion Status 4 bit
1 = Conversion of Channels AN9 and AN8 is pending; set when selected trigger is asserted
0 = Conversion is complete
- bit 5 **SWTRG4**: Software Trigger 4 bit
1 = Starts conversion of AN9 and AN8 (if selected by the TRGSRCx bits)⁽²⁾
 This bit is automatically cleared by hardware when the PEND4 bit is set.
0 = Conversion has not started

- Note 1:** This register is only implemented in the dsPIC33FJ16GS504 devices.
Note 2: The trigger source must be set as a global software trigger prior to setting this bit to '1'. If other conversions are in progress, then the conversion will be performed when the conversion resources are available.

dsPIC33FJ06GS101/X02 and dsPIC33FJ16GSX02/X04

REGISTER 19-7: ADCPC2: ANALOG-TO-DIGITAL CONVERT PAIR CONTROL REGISTER 2⁽¹⁾ (CONTINUED)

bit 4-0 **TRGSRC4<4:0>**: Trigger 4 Source Selection bits
Selects trigger source for conversion of Analog Channels AN9 and AN8.
11111 = Timer2 period match
•
•
•
11011 = Reserved
11010 = PWM Generator 4 current-limit ADC trigger
11001 = PWM Generator 3 current-limit ADC trigger
11000 = PWM Generator 2 current-limit ADC trigger
10111 = PWM Generator 1 current-limit ADC trigger
10110 = Reserved
•
•
•
10010 = Reserved
10001 = PWM Generator 4 secondary trigger is selected
10000 = PWM Generator 3 secondary trigger is selected
01111 = PWM Generator 2 secondary trigger is selected
01110 = PWM Generator 1 secondary trigger is selected
01101 = Reserved
01100 = Timer1 period match
•
•
•
01000 = Reserved
00111 = PWM Generator 4 primary trigger is selected
00110 = PWM Generator 3 primary trigger is selected
00101 = PWM Generator 2 primary trigger is selected
00100 = PWM Generator 1 primary trigger is selected
00011 = PWM Special Event Trigger is selected
00010 = Global software trigger is selected
00001 = Individual software trigger is selected
00000 = No conversion is enabled

Note 1: This register is only implemented in the dsPIC33FJ16GS504 devices.

2: The trigger source must be set as a global software trigger prior to setting this bit to '1'. If other conversions are in progress, then the conversion will be performed when the conversion resources are available.

dsPIC33FJ06GS101/X02 and dsPIC33FJ16GSX02/X04

REGISTER 19-8: ADCPC3: ANALOG-TO-DIGITAL CONVERT PAIR CONTROL REGISTER 3⁽¹⁾

U-0	U-0	U-0	U-0	U-0	U-0	U-0	U-0
—	—	—	—	—	—	—	—
bit 15						bit 8	

R/W-0	R/W-0	R/W-0	R/W-0	R/W-0	R/W-0	R/W-0	R/W-0
IRQEN6	PEND6	SWTRG6	TRGSRC6<4:0>				
bit 7						bit 0	

Legend:

R = Readable bit W = Writable bit U = Unimplemented bit, read as '0'
 -n = Value at POR '1' = Bit is set '0' = Bit is cleared x = Bit is unknown

- bit 15-8 **Unimplemented:** Read as '0'
- bit 7 **IRQEN6:** Interrupt Request Enable 6 bit
 1 = Enables IRQ generation when requested conversion of Channels AN13 and AN12 is completed
 0 = IRQ is not generated
- bit 6 **PEND6:** Pending Conversion Status 6 bit
 1 = Conversion of Channels AN13 and AN 12 is pending; set when selected trigger is asserted
 0 = Conversion is complete
- bit 5 **SWTRG6:** Software Trigger 6 bit
 1 = Starts conversion of AN13 (INTREF) and AN12 (EXTREF) (if selected by the TRGSRCx bits)⁽²⁾
 This bit is automatically cleared by hardware when the PEND6 bit is set.
 0 = Conversion has not started

- Note 1:** This register is only implemented on the dsPIC33FJ16GS502 and dsPIC33FJ16GS504 devices.
- Note 2:** The trigger source must be set as global software trigger prior to setting this bit to '1'. If other conversions are in progress, conversion will be performed when the conversion resources are available.

dsPIC33FJ06GS101/X02 and dsPIC33FJ16GSX02/X04

REGISTER 19-8: ADCPC3: ANALOG-TO-DIGITAL CONVERT PAIR CONTROL REGISTER 3⁽¹⁾

bit 4-0 **TRGSRC6<4:0>**: Trigger 6 Source Selection bits
Selects trigger source for conversion of Analog Channels AN13 and AN12.
11111 = Timer2 period match
•
•
•
11011 = Reserved
11010 = PWM Generator 4 current-limit ADC trigger
11001 = PWM Generator 3 current-limit ADC trigger
11000 = PWM Generator 2 current-limit ADC trigger
10111 = PWM Generator 1 current-limit ADC trigger
10110 = Reserved
•
•
•
10010 = Reserved
10001 = PWM Generator 4 secondary trigger is selected
10000 = PWM Generator 3 secondary trigger is selected
01111 = PWM Generator 2 secondary trigger is selected
01110 = PWM Generator 1 secondary trigger is selected
01101 = Reserved
01100 = Timer1 period match
•
•
•
01000 = Reserved
00111 = PWM Generator 4 primary trigger is selected
00110 = PWM Generator 3 primary trigger is selected
00101 = PWM Generator 2 primary trigger is selected
00100 = PWM Generator 1 primary trigger is selected
00011 = PWM Special Event Trigger is selected
00010 = Global software trigger is selected
00001 = Individual software trigger is selected
00000 = No conversion is enabled

- Note 1:** This register is only implemented on the dsPIC33FJ16GS502 and dsPIC33FJ16GS504 devices.
- 2:** The trigger source must be set as global software trigger prior to setting this bit to '1'. If other conversions are in progress, conversion will be performed when the conversion resources are available.

dsPIC33FJ06GS101/X02 and dsPIC33FJ16GSX02/X04

NOTES:

dsPIC33FJ06GS101/X02 and dsPIC33FJ16GSX02/X04

20.0 HIGH-SPEED ANALOG COMPARATOR

Note 1: This data sheet summarizes the features of the dsPIC33FJ06GS101/X02 and dsPIC33FJ16GSX02/X04 families of devices. It is not intended to be a comprehensive reference source. To complement the information in this data sheet, refer to “**High-Speed Analog Comparator**” (DS70296) in the “*dsPIC33F/PIC24H Family Reference Manual*”, which is available on the Microchip web site (www.microchip.com).

2: Some registers and associated bits described in this section may not be available on all devices. Refer to **Section 4.0 “Memory Organization”** in this data sheet for device-specific register and bit information.

The dsPIC33F SMPS comparator module monitors current and/or voltage transients that may be too fast for the CPU and ADC to capture.

20.1 Features Overview

The SMPS comparator module contains the following major features:

- 16 selectable comparator inputs
- Up to four analog comparators
- 10-bit DAC for each analog comparator

- Programmable output polarity
- Interrupt generation capability
- DACOUT pin to provide DAC output
- DAC has three ranges of operation:
 - $AV_{DD}/2$
 - Internal Reference (INTREF)
 - External Reference (EXTREF)
- ADC sample and convert trigger capability
- Disable capability reduces power consumption
- Functional support for PWM module:
 - PWM duty cycle control
 - PWM period control
 - PWM Fault detect

20.2 Module Description

Figure 20-1 shows a functional block diagram of one analog comparator from the SMPS comparator module. The analog comparator provides high-speed operation with a typical delay of 20 ns. The comparator has a typical offset voltage of ± 5 mV. The negative input of the comparator is always connected to the DAC circuit. The positive input of the comparator is connected to an analog multiplexer that selects the desired source pin.

The analog comparator input pins are typically shared with pins used by the Analog-to-Digital Converter (ADC) module. Both the comparator and the ADC can use the same pins at the same time. This capability enables a user to measure an input voltage with the ADC and detect voltage transients with the comparator.

FIGURE 20-1: HIGH-SPEED ANALOG COMPARATOR MODULE BLOCK DIAGRAM



dsPIC33FJ06GS101/X02 and dsPIC33FJ16GSX02/X04

20.3 Module Applications

This module provides a means for the SMPS dsPIC[®] DSC devices to monitor voltage and currents in a power conversion application. The ability to detect transient conditions and stimulate the dsPIC DSC processor and/or peripherals, without requiring the processor and ADC to constantly monitor voltages or currents, frees the dsPIC DSC to perform other tasks.

The comparator module has a high-speed comparator and an associated 10-bit DAC that provides a programmable reference voltage to the inverting input of the comparator. The polarity of the comparator output is user-programmable. The output of the module can be used in the following modes:

- Generate an Interrupt
- Trigger an ADC Sample and Convert Process
- Truncate the PWM Signal (current limit)
- Truncate the PWM Period (current minimum)
- Disable the PWM Outputs (Fault latch)

The output of the comparator module may be used in multiple modes at the same time, such as: 1) generate an interrupt, 2) have the ADC take a sample and convert it, and 3) truncate the PWM output in response to a voltage being detected beyond its expected value.

The comparator module can also be used to wake-up the system from Sleep or Idle mode when the analog input voltage exceeds the programmed threshold voltage.

20.4 DAC

The range of the DAC is controlled through an analog multiplexer that selects either $AV_{DD}/2$, an internal reference source, INTREF, or an external reference source, EXTREF. The full range of the DAC ($AV_{DD}/2$) will typically be used when the chosen input source pin is shared with the ADC. The reduced range option (INTREF) will likely be used when monitoring current levels using a current sense resistor. Usually, the measured voltages in such applications are small ($<1.25V$); therefore the option of using a reduced reference range for the comparator extends the available DAC resolution in these applications. The use of an external reference enables the user to connect to a reference that better suits their application.

DACOUT, shown in [Figure 20-1](#), can only be associated with a single comparator at a given time.

Note: It should be ensured in software that multiple DACOE bits are not set. The output on the DACOUT pin will be indeterminate if multiple comparators enable the DAC output.

20.5 Interaction with I/O Buffers

If the comparator module is enabled and a pin has been selected as the source for the comparator, then the chosen I/O pad must disable the digital input buffer associated with the pad to prevent excessive currents in the digital buffer due to analog input voltages.

20.6 Digital Logic

The CMPCONx register (see [Register 20-1](#)) provides the control logic that configures the comparator module. The digital logic provides a glitch filter for the comparator output to mask transient signals in less than two instruction cycles. In Sleep or Idle mode, the glitch filter is bypassed to enable an asynchronous path from the comparator to the interrupt controller. This asynchronous path can be used to wake-up the processor from Sleep or Idle mode.

The comparator can be disabled while in Idle mode if the CMPSIDL bit is set. If a device has multiple comparators, if any CMPSIDL bit is set, then the entire group of comparators will be disabled while in Idle mode. This behavior reduces complexity in the design of the clock control logic for this module.

The digital logic also provides a one T_{CY} width pulse generator for triggering the ADC and generating interrupt requests.

The CMPDACx (see [Register 20-2](#)) register provides the digital input value to the reference DAC.

If the module is disabled, the DAC and comparator are disabled to reduce power consumption.

20.7 Comparator Input Range

The comparator has a limitation for the input Common-Mode Range (CMR) of $(AV_{DD} - 1.5V)$, typical. This means that both inputs should not exceed this range. As long as one of the inputs is within the Common-Mode Range, the comparator output will be correct. However, any input exceeding the CMR limitation will cause the comparator input to be saturated.

If both inputs exceed the CMR, the comparator output will be indeterminate.

20.8 DAC Output Range

The DAC has a limitation for the maximum reference voltage input of $(AV_{DD} - 1.6)$ volts. An external reference voltage input should not exceed this value or the reference DAC output will become indeterminate.

20.9 Comparator Registers

The comparator module is controlled by the following registers:

- [CMPCONx: Comparator Control x Register](#)
- [CMPDACx: Comparator DAC x Control Register](#)

dsPIC33FJ06GS101/X02 and dsPIC33FJ16GSX02/X04

REGISTER 20-1: CMPCONx: COMPARATOR CONTROL x REGISTER

R/W-0	U-0	R/W-0	r-0	r-0	r-0	r-0	R/W-0
CMPON	—	CMPSIDL	r	r	r	r	DACOE
bit 15							bit 8

R/W-0	R/W-0	R/W-0	r-0	R/W-0	r-0	R/W-0	R/W-0
INSEL1	INSEL0	EXTREF	r	CMPSTAT	r	CMPPOL	RANGE
bit 7							bit 0

Legend:	r = Reserved bit
R = Readable bit	W = Writable bit
-n = Value at POR	'1' = Bit is set
	U = Unimplemented bit, read as '0'
	'0' = Bit is cleared
	x = Bit is unknown

- bit 15 **CMPON:** Comparator Operating Mode bit
1 = Comparator module is enabled
0 = Comparator module is disabled (reduces power consumption)
- bit 14 **Unimplemented:** Read as '0'
- bit 13 **CMPSIDL:** Comparator Stop in Idle Mode bit
1 = Discontinues module operation when device enters Idle mode.
0 = Continues module operation in Idle mode
If a device has multiple comparators, any CMPSIDL bit set to '1' disables **ALL** comparators while in Idle mode.
- bit 12-9 **Reserved:** Read as '0'
- bit 8 **DACOE:** DAC Output Enable
1 = DAC analog voltage is output to the DACOUT pin⁽¹⁾
0 = DAC analog voltage is not connected to the DACOUT pin
- bit 7-6 **INSEL<1:0>:** Input Source Select for Comparator bits
00 = Selects CMPxA input pin
01 = Selects CMPxB input pin
10 = Selects CMPxC input pin
11 = Selects CMPxD input pin
- bit 5 **EXTREF:** Enable External Reference bit
1 = External source provides reference to the DAC (maximum DAC voltage determined by the external voltage source)
0 = Internal reference sources provide reference to the DAC (maximum DAC voltage determined by the RANGE bit setting)
- bit 4 **Reserved:** Read as '0'
- bit 3 **CMPSTAT:** Current State of Comparator Output Including CMPPOL Selection bit
- bit 2 **Reserved:** Read as '0'
- bit 1 **CMPPOL:** Comparator Output Polarity Control bit
1 = Output is inverted
0 = Output is non-inverted
- bit 0 **RANGE:** Selects DAC Output Voltage Range bit
1 = High Range: Max DAC Value = AVDD/2, 1.65V at 3.3V AVDD
0 = Low Range: Max DAC Value = INTREF⁽²⁾

Note 1: DACOUT can be associated only with a single comparator at any given time. The software must ensure that multiple comparators do not enable the DAC output by setting their respective DACOE bit.

2: Refer to the DAC Module Specifications (Table 24-43) in Section 24.0 "Electrical Characteristics" for the INTREF value.

dsPIC33FJ06GS101/X02 and dsPIC33FJ16GSX02/X04

REGISTER 20-2: CMPDACx: COMPARATOR DAC x CONTROL REGISTER

r-0	r-0	r-0	r-0	r-0	r-0	R/W-0	R/W-0
r	r	r	r	r	r	CMREF<9:8>	
bit 15						bit 8	

R/W-0	R/W-0	R/W-0	R/W-0	R/W-0	R/W-0	R/W-0	R/W-0
CMREF<7:0>							
bit 7						bit 0	

Legend:	r = Reserved bit		
R = Readable bit	W = Writable bit	U = Unimplemented bit, read as '0'	
-n = Value at POR	'1' = Bit is set	'0' = Bit is cleared	x = Bit is unknown

bit 15-10 **Reserved:** Read as '0'

bit 9-0 **CMREF<9:0>:** Comparator Reference Voltage Select bits

1111111111 = (CMREF<9:0> * INTREF/1024) or (CMREF<9:0> * (AVDD/2)/1024) volts depending on the RANGE bit or (CMREF<9:0> * EXTREF/1024) if EXTREF is set

-
-
-

0000000000 = 0.0 volts

dsPIC33FJ06GS101/X02 and dsPIC33FJ16GSX02/X04

21.0 SPECIAL FEATURES

Note 1: This data sheet summarizes the features of the dsPIC33FJ06GS101/X02 and dsPIC33FJ16GSX02/X04 devices. It is not intended to be a comprehensive reference source. To complement the information in this data sheet, refer to the “dsPIC33F/PIC24H Family Reference Manual”. Please see the Microchip web site (www.microchip.com) for the latest “dsPIC33F/PIC24H Family Reference Manual” sections.

2: Some registers and associated bits described in this section may not be available on all devices. Refer to [Section 4.0 “Memory Organization”](#) in this data sheet for device-specific register and bit information.

dsPIC33FJ06GS101/X02 and dsPIC33FJ16GSX02/X04 devices include several features intended to maximize application flexibility and reliability, and minimize cost through elimination of external components. These are:

- Flexible Configuration
- Watchdog Timer (WDT)
- Code Protection and CodeGuard™ Security
- JTAG Boundary Scan Interface
- In-Circuit Serial Programming™ (ICSP™)
- In-Circuit Emulation
- Brown-out Reset (BOR)

21.1 Configuration Bits

dsPIC33FJ06GS101/X02 and dsPIC33FJ16GSX02/X04 devices provide nonvolatile memory implementations for device Configuration bits. Refer to “**Device Configuration**” (DS70194) in the “dsPIC33F/PIC24H Family Reference Manual” for more information on this implementation.

The Configuration bits can be programmed (read as ‘0’), or left unprogrammed (read as ‘1’), to select various device configurations. These bits are mapped starting at program memory location 0xF80000.

The individual Configuration bit descriptions for the Configuration registers are shown in [Table 21-2](#).

Note that address, 0xF80000, is beyond the user program memory space. It belongs to the configuration memory space (0x800000-0xFFFFF), which can only be accessed using Table Reads and Table Writes.

The device Configuration register map is shown in [Table 21-1](#).

TABLE 21-1: DEVICE CONFIGURATION REGISTER MAP

Address	Name	Bit 7	Bit 6	Bit 5	Bit 4	Bit 3	Bit 2	Bit 1	Bit 0
0xF80000	FBS	—	—	—	—	BSS2	BSS1	BSS0	BWRP
0xF80002	Reserved	—	—	—	—	—	—	—	—
0xF80004	FGS	—	—	—	—	—	GSS1	GSS0	GWRP
0xF80006	FOSCSEL	IESO	—	—	—	—	FNOSC2	FNOSC1	FNOSC0
0xF80008	FOSC	FCKSM1	FCKSM0	IOL1WAY	—	—	OSCIOFNC	POSCMD1	POSCMD0
0xF8000A	FWDT	FWDTEN	WINDIS	—	WDTPRE	WDTPOST3	WDTPOST2	WDTPOST1	WDTPOST0
0xF8000C	FPOR	—	—	—	—	Reserved ⁽²⁾	FPWRT2	FPWRT1	FPWRT0
0xF8000E	FICD	Reserved ⁽¹⁾		JTAGEN	—	—	—	ICS1	ICS0
0xF80010	FUID0	User Unit ID Byte 0							
0xF80012	FUID1	User Unit ID Byte 1							

Legend: — = unimplemented bit, read as ‘0’.

Note 1: These bits are reserved for use by development tools and must be programmed to ‘1’.

2: This bit reads the current programmed value.

dsPIC33FJ06GS101/X02 and dsPIC33FJ16GSX02/X04

TABLE 21-2: dsPIC33F CONFIGURATION BITS DESCRIPTION

Bit Field	Register	RTSP Effect	Description
BWRP	FBS	Immediate	Boot Segment Program Flash Write Protection bit 1 = Boot segment can be written 0 = Boot segment is write-protected
BSS<2:0>	FBS	Immediate	Boot Segment Program Flash Code Protection Size bits x11 = No boot program Flash segment <u>Boot Space is 256 Instruction Words (except interrupt vectors):</u> 110 = Standard security; boot program Flash segment ends at 0x0003FE 010 = High security; boot program Flash segment ends at 0x0003FE <u>Boot Space is 768 Instruction Words (except interrupt vectors):</u> 101 = Standard security; boot program Flash segment ends at 0x0007FE 001 = High security; boot program Flash segment ends at 0x0007FE <u>Boot Space is 1792 Instruction Words (except interrupt vectors):</u> 100 = Standard security; boot program Flash segment ends at 0x000FFE 000 = High security; boot program Flash segment ends at 0x000FFE
GSS<1:0>	FGS	Immediate	General Segment Code-Protect bits 11 = User program memory is not code-protected 10 = Standard security 0x = High security
GWRP	FGS	Immediate	General Segment Write-Protect bit 1 = User program memory is not write-protected 0 = User program memory is write-protected
IESO	FOSCSEL	Immediate	Two-speed Oscillator Start-up Enable bit 1 = Start-up device with FRC, then automatically switch to the user-selected oscillator source when ready 0 = Start-up device with user-selected oscillator source
FNOSC<2:0>	FOSCSEL	If clock switch is enabled, RTSP effect is on any device Reset; otherwise, Immediate	Initial Oscillator Source Selection bits 111 = Internal Fast RC (FRC) Oscillator with Postscaler 110 = Internal Fast RC (FRC) Oscillator with Divide-by-16 101 = LPRC Oscillator 100 = Reserved 011 = Primary (XT, HS, EC) Oscillator with PLL 010 = Primary (XT, HS, EC) Oscillator 001 = Internal Fast RC (FRC) Oscillator with PLL 000 = FRC Oscillator
FCKSM<1:0>	FOSC	Immediate	Clock Switching Mode bits 1x = Clock switching is disabled, Fail-Safe Clock Monitor is disabled 01 = Clock switching is enabled, Fail-Safe Clock Monitor is disabled 00 = Clock switching is enabled, Fail-Safe Clock Monitor is enabled
IOL1WAY	FOSC	Immediate	Peripheral Pin Select Configuration bit 1 = Allows only one reconfiguration 0 = Allows multiple reconfigurations
OSCI0FNC	FOSC	Immediate	OSC2 Pin Function bit (except in XT and HS modes) 1 = OSC2 is the clock output 0 = OSC2 is the general purpose digital I/O pin

dsPIC33FJ06GS101/X02 and dsPIC33FJ16GSX02/X04

TABLE 21-2: dsPIC33F CONFIGURATION BITS DESCRIPTION (CONTINUED)

Bit Field	Register	RTSP Effect	Description
POSCMD<1:0>	FOSC	Immediate	Primary Oscillator Mode Select bits 11 = Primary Oscillator is disabled 10 = HS Crystal Oscillator mode 01 = XT Crystal Oscillator mode 00 = EC (External Clock) mode
FWDTEN	FWDT	Immediate	Watchdog Timer Enable bit 1 = Watchdog Timer is always enabled (LPRC oscillator cannot be disabled; clearing the SWDTEN bit in the RCON register will have no effect) 0 = Watchdog Timer is enabled/disabled by user software (LPRC can be disabled by clearing the SWDTEN bit in the RCON register)
WINDIS	FWDT	Immediate	Watchdog Timer Window Enable bit 1 = Watchdog Timer in Non-Window mode 0 = Watchdog Timer in Window mode
WDTPRE	FWDT	Immediate	Watchdog Timer Prescaler bit 1 = 1:128 0 = 1:32
WDTPOST<3:0>	FWDT	Immediate	Watchdog Timer Postscaler bits 1111 = 1:32,768 1110 = 1:16,384 • • • 0001 = 1:2 0000 = 1:1
FPWRT<2:0>	FPOR	Immediate	Power-on Reset Timer Value Select bits 111 = PWRT = 128 ms 110 = PWRT = 64 ms 101 = PWRT = 32 ms 100 = PWRT = 16 ms 011 = PWRT = 8 ms 010 = PWRT = 4 ms 001 = PWRT = 2 ms 000 = PWRT = Disabled
JTAGEN	FICD	Immediate	JTAG Enable bit 1 = JTAG is enabled 0 = JTAG is disabled
ICS<1:0>	FICD	Immediate	ICD Communication Channel Select Enable bits 11 = Communicates on PGEC1 and PGED1 10 = Communicates on PGEC2 and PGED2 01 = Communicates on PGEC3 and PGED3 00 = Reserved, do not use.

dsPIC33FJ06GS101/X02 and dsPIC33FJ16GSX02/X04

21.2 On-Chip Voltage Regulator

The dsPIC33FJ06GS101/X02 and dsPIC33FJ16GSX02/X04 devices power their core digital logic at a nominal 2.5V. This can create a conflict for designs that are required to operate at a higher typical voltage, such as 3.3V. To simplify system design, all devices in the dsPIC33FJ06GS101/X02 and dsPIC33FJ16GSX02/X04 families incorporate an on-chip regulator that allows the device to run its core logic from VDD.

The regulator provides power to the core from the other VDD pins. When the regulator is enabled, a low-ESR (less than 5 ohms) capacitor (such as tantalum or ceramic) must be connected to the VCAP pin (Figure 21-1). This helps to maintain the stability of the regulator. The recommended value for the filter capacitor is provided in Table 24-13 located in Section 24.1 “DC Characteristics”.

Note: It is important for the low-ESR capacitor to be placed as close as possible to the VCAP pin.

On a POR, it takes approximately 20 μ s for the on-chip voltage regulator to generate an output voltage. During this time, designated as TSTARTUP, code execution is disabled. TSTARTUP is applied every time the device resumes operation after any power-down.

FIGURE 21-1: CONNECTIONS FOR THE ON-CHIP VOLTAGE REGULATOR^(1,2,3)



21.3 BOR: Brown-out Reset

The Brown-out Reset (BOR) module is based on an internal voltage reference circuit. The main purpose of the BOR module is to generate a device Reset when a brown-out condition occurs. Brown-out conditions are generally caused by glitches on the AC mains (for example, missing portions of the AC cycle waveform due to bad power transmission lines, or voltage sags due to excessive current draw when a large inductive load is turned on).

A BOR generates a Reset pulse, which resets the device. The BOR selects the clock source, based on the device Configuration bit values (FNOSC<2:0> and POSCMD<1:0>).

If an oscillator mode is selected, the BOR activates the Oscillator Start-up Timer (OST). The system clock is held until OST expires. If the PLL is used, the clock is held until the LOCK bit (OSCCON<5>) is '1'.

Concurrently, the PWRT time-out (TPWRT) is applied before the internal Reset is released. If TPWRT = 0 and a crystal oscillator is being used, then a nominal delay of TFSCM = 100 is applied. The total delay in this case is TFSCM.

The BOR Status bit (RCON<1>) is set to indicate that a BOR has occurred. The BOR circuit continues to operate while in Sleep or Idle modes and resets the device should VDD fall below the BOR threshold voltage.

dsPIC33FJ06GS101/X02 and dsPIC33FJ16GSX02/X04

21.4 Watchdog Timer (WDT)

For the dsPIC33FJ06GS101/X02 and dsPIC33FJ16GSX02/X04 devices, the WDT is driven by the LPRC oscillator. When the WDT is enabled, the clock source is also enabled.

21.4.1 PRESCALER/POSTSCALER

The nominal WDT clock source from LPRC is 32 kHz. This feeds a prescaler that can be configured for either 5-bit (divide-by-32) or 7-bit (divide-by-128) operation. The prescaler is set by the WDTPRE Configuration bit. With a 32 kHz input, the prescaler yields a nominal WDT time-out period (T_{WDT}) of 1 ms in 5-bit mode, or 4 ms in 7-bit mode.

A variable postscaler divides down the WDT prescaler output and allows for a wide range of time-out periods. The postscaler is controlled by the WDTPOST<3:0> Configuration bits (FWDT<3:0>) which allow the selection of 16 settings, from 1:1 to 1:32,768. Using the prescaler and postscaler, time-out periods ranging from 1 ms to 131 seconds can be achieved.

The WDT, prescaler and postscaler are reset:

- On any device Reset
- On the completion of a clock switch, whether invoked by software (i.e., setting the OSWEN bit after changing the NOSC<2:0> bits) or by hardware (i.e., Fail-Safe Clock Monitor)
- When a PWRSAV instruction is executed (i.e., Sleep or Idle mode is entered)
- When the device exits Sleep or Idle mode to resume normal operation
- By a CLRWDT instruction during normal execution

Note: The CLRWDT and PWRSAV instructions clear the prescaler and postscaler counts when executed.

21.4.2 SLEEP AND IDLE MODES

If the WDT is enabled, it will continue to run during Sleep or Idle modes. When the WDT time-out occurs, the device will wake the device and code execution will continue from where the PWRSAV instruction was executed. The corresponding SLEEP bit (RCON<3>) or IDLE bit (RCON<2>) will need to be cleared in software after the device wakes up.

21.4.3 ENABLING WDT

The WDT is enabled or disabled by the FWDTEN Configuration bit in the FWDT Configuration register. When the FWDTEN Configuration bit is set, the WDT is always enabled.

The WDT can be optionally controlled in software when the FWDTEN Configuration bit has been programmed to '0'. The WDT is enabled in software by setting the SWDTEN control bit (RCON<5>). The SWDTEN control bit is cleared on any device Reset. The software WDT option allows the user application to enable the WDT for critical code segments and disable the WDT during non-critical segments for maximum power savings.

Note: If the WINDIS bit (FWDT<6>) is cleared, the CLRWDT instruction should be executed by the application software only during the last 1/4 of the WDT period. This CLRWDT window can be determined by using a timer. If a CLRWDT instruction is executed before this window, a WDT Reset occurs.

The WDT flag bit, WDTO (RCON<4>), is not automatically cleared following a WDT time-out. To detect subsequent WDT events, the flag must be cleared in software.

FIGURE 21-2: WDT BLOCK DIAGRAM

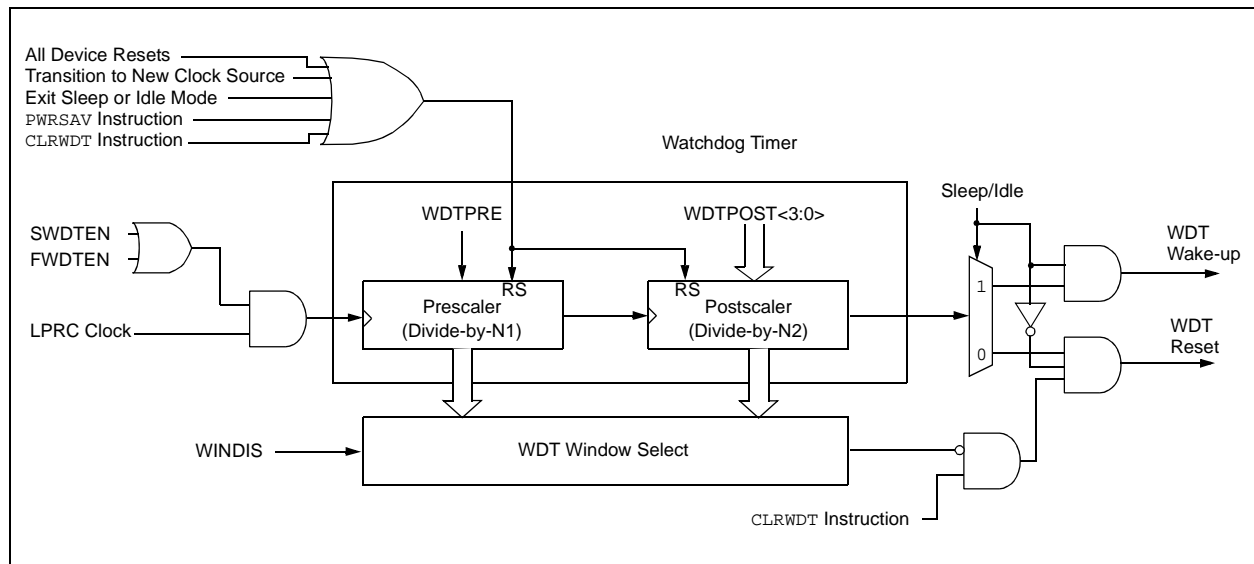

dsPIC33FJ06GS101/X02 and dsPIC33FJ16GSX02/X04

21.5 JTAG Interface

The dsPIC33FJ06GS101/X02 and dsPIC33FJ16GSX02/X04 devices implement a JTAG interface, which supports boundary scan device testing. Detailed information on this interface will be provided in future revisions of the document.

21.6 In-Circuit Serial Programming

The dsPIC33FJ06GS101/X02 and dsPIC33FJ16GSX02/X04 family of Digital Signal Controllers can be serially programmed while in the end application circuit. This is done with two lines for clock and data and three other lines for power, ground and the programming sequence. Serial programming allows customers to manufacture boards with unprogrammed devices and then program the Digital Signal Controller just before shipping the product. Serial programming also allows the most recent firmware or a custom firmware to be programmed. Refer to the “*dsPIC33F/PIC24H Flash Programming Specification*” (DS70152) for details about In-Circuit Serial Programming (ICSP).

Any of the three pairs of programming clock/data pins can be used:

- PGEC1 and PGED1
- PGEC2 and PGED2
- PGEC3 and PGED3

21.7 In-Circuit Debugger

The dsPIC33FJ06GS101/X02 and dsPIC33FJ16GSX02/X04 devices provide simple debugging functionality through the PGECx (Emulation/Debug Clock) and PGEDx (Emulation/Debug Data) pin functions.

Any of the three pairs of debugging clock/data pins can be used:

- PGEC1 and PGED1
- PGEC2 and PGED2
- PGEC3 and PGED3

To use the in-circuit debugger function of the device, the design must implement ICSP connections to $\overline{\text{MCLR}}$, V_{DD} , V_{SS} , and the PGECx/PGEDx pin pair. In addition, when the feature is enabled, some of the resources are not available for general use. These resources include the first 80 bytes of data RAM and two I/O pins.

dsPIC33FJ06GS101/X02 and dsPIC33FJ16GSX02/X04

21.8 Code Protection and CodeGuard™ Security

The dsPIC33FJ06GS101/X02 and dsPIC33FJ16GSX02/X04 devices offer the intermediate implementation of CodeGuard™ Security. CodeGuard Security enables multiple parties to securely share resources (memory, interrupts and peripherals) on a single chip. This feature helps protect individual Intellectual Property (IP) in collaborative system designs.

When coupled with software encryption libraries, CodeGuard™ Security can be used to securely update Flash even when multiple IPs reside on a single chip.

The code protection features are controlled by the Configuration registers: FBS and FGS.

Secure segment and RAM protection is not implemented in dsPIC33FJ06GS101/X02 and dsPIC33FJ16GSX02/X04 devices.

Note: Refer to “CodeGuard™ Security” (DS70199) for further information on CodeGuard Security usage, configuration and operation.

TABLE 21-3: CODE FLASH SECURITY SEGMENT SIZES FOR 6-Kbyte DEVICES

Configuration Bits		
BSS<2:0> = x11 0K	VS = 256 IW	000000h 0001FEh 000200h 0003FEh 000400h 0007FEh 000800h 000FFEh 001000h
	GS = 1792 IW	002BFEh
BSS<2:0> = x10 256	VS = 256 IW	000000h 0001FEh 000200h 0003FEh 000400h 0007FEh 000800h 000FFEh 001000h
	GS = 1536 IW	002BFEh
BSS<2:0> = x01 768	VS = 256 IW	000000h 0001FEh 000200h 0003FEh 000400h 0007FEh 000800h 000FFEh 001000h
	GS = 1024 IW	002BFEh
BSS<2:0> = x00 1792	VS = 256 IW	000000h 0001FEh 000200h 0003FEh 000400h 0007FEh 000800h 000FFEh 001000h
	GS = 1792 IW	002BFEh

TABLE 21-4: CODE FLASH SECURITY SEGMENT SIZES FOR 16-Kbyte DEVICES

Configuration Bits		
BSS<2:0> = x11 0K	VS = 256 IW	000000h 0001FEh 000200h 0003FEh 000400h 0007FEh 000800h 000FFEh 001000h
	GS = 5376 IW	002BFEh
BSS<2:0> = x10 256	VS = 256 IW	000000h 0001FEh 000200h 0003FEh 000400h 0007FEh 000800h 000FFEh 001000h
	GS = 5120 IW	002BFEh
BSS<2:0> = x01 768	VS = 256 IW	000000h 0001FEh 000200h 0003FEh 000400h 0007FEh 000800h 000FFEh 001000h
	GS = 4608 IW	002BFEh
BSS<2:0> = x00 1792	VS = 256 IW	000000h 0001FEh 000200h 0003FEh 000400h 0007FEh 000800h 000FFEh 001000h
	GS = 3584 IW	002BFEh

dsPIC33FJ06GS101/X02 and dsPIC33FJ16GSX02/X04

NOTES:

22.0 INSTRUCTION SET SUMMARY

Note: This data sheet summarizes the features of the dsPIC33FJ06GS101/X02 and dsPIC33FJ16GSX02/X04 devices. It is not intended to be a comprehensive reference source. To complement the information in this data sheet, refer to the latest sections in the “*dsPIC33F/PIC24H Family Reference Manual*”, which are available on the Microchip web site (www.microchip.com).

The dsPIC33F instruction set is identical to that of the dsPIC30F.

Most instructions are a single program memory word (24 bits). Only three instructions require two program memory locations.

Each single-word instruction is a 24-bit word, divided into an 8-bit opcode, which specifies the instruction type and one or more operands, which further specify the operation of the instruction.

The instruction set is highly orthogonal and is grouped into five basic categories:

- Word or byte-oriented operations
- Bit-oriented operations
- Literal operations
- DSP operations
- Control operations

Table 22-1 shows the general symbols used in describing the instructions.

The dsPIC33F instruction set summary in Table 22-2 lists all the instructions, along with the status flags affected by each instruction.

Most word or byte-oriented W register instructions (including barrel shift instructions) have three operands:

- The first source operand, which is typically a register ‘Wb’ without any address modifier
- The second source operand, which is typically a register ‘Ws’ with or without an address modifier
- The destination of the result, which is typically a register ‘Wd’ with or without an address modifier

However, word or byte-oriented file register instructions have two operands:

- The file register specified by the value, ‘f’
- The destination, which could be either the file register, ‘f’, or the W0 register, which is denoted as ‘WREG’

Most bit-oriented instructions (including simple rotate/shift instructions) have two operands:

- The W register (with or without an address modifier) or file register (specified by the value of ‘Ws’ or ‘f’)
- The bit in the W register or file register (specified by a literal value or indirectly by the contents of register ‘Wb’)

The literal instructions that involve data movement can use some of the following operands:

- A literal value to be loaded into a W register or file register (specified by ‘k’)
- The W register or file register where the literal value is to be loaded (specified by ‘Wb’ or ‘f’)

However, literal instructions that involve arithmetic or logical operations use some of the following operands:

- The first source operand, which is a register ‘Wb’ without any address modifier
- The second source operand, which is a literal value
- The destination of the result (only if not the same as the first source operand), which is typically a register ‘Wd’ with or without an address modifier

The MAC class of DSP instructions can use some of the following operands:

- The accumulator (A or B) to be used (required operand)
- The W registers to be used as the two operands
- The X and Y address space prefetch operations
- The X and Y address space prefetch destinations
- The accumulator write-back destination

The other DSP instructions do not involve any multiplication and can include:

- The accumulator to be used (required)
- The source or destination operand (designated as Wso or Wdo, respectively) with or without an address modifier
- The amount of shift specified by a W register, ‘Wn’, or a literal value

The control instructions can use some of the following operands:

- A program memory address
- The mode of the Table Read and Table Write instructions

dsPIC33FJ06GS101/X02 and dsPIC33FJ16GSX02/X04

Most instructions are a single word. Certain double-word instructions are designed to provide all the required information in these 48 bits. In the second word, the 8 MSBs are '0's. If this second word is executed as an instruction (by itself), it will execute as a NOP.

The double-word instructions execute in two instruction cycles.

Most single-word instructions are executed in a single instruction cycle, unless a conditional test is true, or the Program Counter is changed as a result of the instruction. In these cases, the execution takes two instruction cycles with the additional instruction cycle(s) executed as a NOP. Notable exceptions are the BRA

(unconditional/computed branch), indirect CALL/GOTO, all Table Reads and Table Writes and RETURN/RETFIE instructions, which are single-word instructions but take two or three cycles. Certain instructions that involve skipping over the subsequent instruction require either two or three cycles if the skip is performed, depending on whether the instruction being skipped is a single-word or two-word instruction. Moreover, double-word moves require two cycles.

Note: For more details on the instruction set, refer to the "16-bit MCU and DSC Programmer's Reference Manual" (DS70157).

TABLE 22-1: SYMBOLS USED IN OPCODE DESCRIPTIONS

Field	Description
#text	Means literal defined by "text"
(text)	Means "content of text"
[text]	Means "the location addressed by text"
{ }	Optional field or operation
<n:m>	Register bit field
.b	Byte mode selection
.d	Double-Word mode selection
.S	Shadow register select
.w	Word mode selection (default)
Acc	One of two accumulators {A, B}
AWB	Accumulator Write-Back Destination Address register $\in \{W13, [W13]+ = 2\}$
bit4	4-bit bit selection field (used in word-addressed instructions) $\in \{0...15\}$
C, DC, N, OV, Z	MCU Status bits: Carry, Digit Carry, Negative, Overflow, Sticky Zero
Expr	Absolute address, label or expression (resolved by the linker)
f	File register address $\in \{0x0000...0x1FFF\}$
lit1	1-bit unsigned literal $\in \{0,1\}$
lit4	4-bit unsigned literal $\in \{0...15\}$
lit5	5-bit unsigned literal $\in \{0...31\}$
lit8	8-bit unsigned literal $\in \{0...255\}$
lit10	10-bit unsigned literal $\in \{0...255\}$ for Byte mode, $\{0:1023\}$ for Word mode
lit14	14-bit unsigned literal $\in \{0...16384\}$
lit16	16-bit unsigned literal $\in \{0...65535\}$
lit23	23-bit unsigned literal $\in \{0...8388608\}$; LSb must be '0'
None	Field does not require an entry, can be blank
OA, OB, SA, SB	DSP Status bits: ACCA Overflow, ACCB Overflow, ACCA Saturate, ACCB Saturate
PC	Program Counter
Slit10	10-bit signed literal $\in \{-512...511\}$
Slit16	16-bit signed literal $\in \{-32768...32767\}$
Slit6	6-bit signed literal $\in \{-16...16\}$
Wb	Base W register $\in \{W0..W15\}$
Wd	Destination W register $\in \{Wd, [Wd], [Wd++] , [Wd--], [++Wd], [--Wd] \}$
Wdo	Destination W register $\in \{Wnd, [Wnd], [Wnd++] , [Wnd--], [++Wnd], [--Wnd], [Wnd+Wb] \}$
Wm,Wn	Dividend, Divisor Working register pair (Direct Addressing)

dsPIC33FJ06GS101/X02 and dsPIC33FJ16GSX02/X04

TABLE 22-1: SYMBOLS USED IN OPCODE DESCRIPTIONS (CONTINUED)

Field	Description
Wm*Wm	Multiplicand and Multiplier Working register pair for Square instructions \in {W4 * W4, W5 * W5, W6 * W6, W7 * W7}
Wm*Wn	Multiplicand and Multiplier Working register pair for DSP instructions \in {W4 * W5, W4 * W6, W4 * W7, W5 * W6, W5 * W7, W6 * W7}
Wn	One of 16 Working registers \in {W0..W15}
Wnd	One of 16 Destination Working registers \in {W0...W15}
Wns	One of 16 Source Working registers \in {W0...W15}
WREG	W0 (Working register used in file register instructions)
Ws	Source W register \in { Ws, [Ws], [Ws++], [Ws--], [++Ws], [--Ws] }
Wso	Source W register \in { Wns, [Wns], [Wns++], [Wns--], [++Wns], [--Wns], [Wns+Wb] }
Wx	X Data Space Prefetch Address register for DSP instructions \in {[W8] + = 6, [W8] + = 4, [W8] + = 2, [W8], [W8] - = 6, [W8] - = 4, [W8] - = 2, [W9] + = 6, [W9] + = 4, [W9] + = 2, [W9], [W9] - = 6, [W9] - = 4, [W9] - = 2, [W9 + W12], none}
Wxd	X Data Space Prefetch Destination register for DSP instructions \in {W4...W7}
Wy	Y Data Space Prefetch Address register for DSP instructions \in {[W10] + = 6, [W10] + = 4, [W10] + = 2, [W10], [W10] - = 6, [W10] - = 4, [W10] - = 2, [W11] + = 6, [W11] + = 4, [W11] + = 2, [W11], [W11] - = 6, [W11] - = 4, [W11] - = 2, [W11 + W12], none}
Wyd	Y Data Space Prefetch Destination register for DSP instructions \in {W4...W7}

dsPIC33FJ06GS101/X02 and dsPIC33FJ16GSX02/X04

TABLE 22-2: INSTRUCTION SET OVERVIEW

Base Instr #	Assembly Mnemonic	Assembly Syntax	Description	# of Words	# of Cycles	Status Flags Affected
1	ADD	ADD <i>Acc</i>	Add Accumulators	1	1	OA,OB,SA,SB
		ADD <i>f</i>	$f = f + WREG$	1	1	C,DC,N,OV,Z
		ADD <i>f, WREG</i>	$WREG = f + WREG$	1	1	C,DC,N,OV,Z
		ADD <i>#lit10, Wn</i>	$Wd = lit10 + Wd$	1	1	C,DC,N,OV,Z
		ADD <i>Wb, Ws, Wd</i>	$Wd = Wb + Ws$	1	1	C,DC,N,OV,Z
		ADD <i>Wb, #lit5, Wd</i>	$Wd = Wb + lit5$	1	1	C,DC,N,OV,Z
		ADD <i>Wso, #Slit4, Acc</i>	16-bit Signed Add to Accumulator	1	1	OA,OB,SA,SB
2	ADDC	ADDC <i>f</i>	$f = f + WREG + (C)$	1	1	C,DC,N,OV,Z
		ADDC <i>f, WREG</i>	$WREG = f + WREG + (C)$	1	1	C,DC,N,OV,Z
		ADDC <i>#lit10, Wn</i>	$Wd = lit10 + Wd + (C)$	1	1	C,DC,N,OV,Z
		ADDC <i>Wb, Ws, Wd</i>	$Wd = Wb + Ws + (C)$	1	1	C,DC,N,OV,Z
		ADDC <i>Wb, #lit5, Wd</i>	$Wd = Wb + lit5 + (C)$	1	1	C,DC,N,OV,Z
3	AND	AND <i>f</i>	$f = f .AND. WREG$	1	1	N,Z
		AND <i>f, WREG</i>	$WREG = f .AND. WREG$	1	1	N,Z
		AND <i>#lit10, Wn</i>	$Wd = lit10 .AND. Wd$	1	1	N,Z
		AND <i>Wb, Ws, Wd</i>	$Wd = Wb .AND. Ws$	1	1	N,Z
		AND <i>Wb, #lit5, Wd</i>	$Wd = Wb .AND. lit5$	1	1	N,Z
4	ASR	ASR <i>f</i>	$f = \text{Arithmetic Right Shift } f$	1	1	C,N,OV,Z
		ASR <i>f, WREG</i>	$WREG = \text{Arithmetic Right Shift } f$	1	1	C,N,OV,Z
		ASR <i>Ws, Wd</i>	$Wd = \text{Arithmetic Right Shift } Ws$	1	1	C,N,OV,Z
		ASR <i>Wb, Wns, Wnd</i>	$Wnd = \text{Arithmetic Right Shift } Wb \text{ by } Wns$	1	1	N,Z
		ASR <i>Wb, #lit5, Wnd</i>	$Wnd = \text{Arithmetic Right Shift } Wb \text{ by } lit5$	1	1	N,Z
5	BCLR	BCLR <i>f, #bit4</i>	Bit Clear <i>f</i>	1	1	None
		BCLR <i>Ws, #bit4</i>	Bit Clear <i>Ws</i>	1	1	None
6	BRA	BRA <i>C, Expr</i>	Branch if Carry	1	1 (2)	None
		BRA <i>GE, Expr</i>	Branch if Greater Than or Equal	1	1 (2)	None
		BRA <i>GEU, Expr</i>	Branch if Unsigned Greater Than or Equal	1	1 (2)	None
		BRA <i>GT, Expr</i>	Branch if Greater Than	1	1 (2)	None
		BRA <i>GTU, Expr</i>	Branch if Unsigned Greater Than	1	1 (2)	None
		BRA <i>LE, Expr</i>	Branch if Less Than or Equal	1	1 (2)	None
		BRA <i>LEU, Expr</i>	Branch if Unsigned Less Than or Equal	1	1 (2)	None
		BRA <i>LT, Expr</i>	Branch if Less Than	1	1 (2)	None
		BRA <i>LTU, Expr</i>	Branch if Unsigned Less Than	1	1 (2)	None
		BRA <i>N, Expr</i>	Branch if Negative	1	1 (2)	None
		BRA <i>NC, Expr</i>	Branch if Not Carry	1	1 (2)	None
		BRA <i>NN, Expr</i>	Branch if Not Negative	1	1 (2)	None
		BRA <i>NOV, Expr</i>	Branch if Not Overflow	1	1 (2)	None
		BRA <i>NZ, Expr</i>	Branch if Not Zero	1	1 (2)	None
		BRA <i>OA, Expr</i>	Branch if Accumulator A Overflow	1	1 (2)	None
		BRA <i>OB, Expr</i>	Branch if Accumulator B Overflow	1	1 (2)	None
		BRA <i>OV, Expr</i>	Branch if Overflow	1	1 (2)	None
		BRA <i>SA, Expr</i>	Branch if Accumulator A Saturated	1	1 (2)	None
		BRA <i>SB, Expr</i>	Branch if Accumulator B Saturated	1	1 (2)	None
		BRA <i>Expr</i>	Branch Unconditionally	1	2	None
BRA <i>Z, Expr</i>	Branch if Zero	1	1 (2)	None		
BRA <i>Wn</i>	Computed Branch	1	2	None		
7	BSET	BSET <i>f, #bit4</i>	Bit Set <i>f</i>	1	1	None
		BSET <i>Ws, #bit4</i>	Bit Set <i>Ws</i>	1	1	None
8	BSW	BSW.C <i>Ws, Wb</i>	Write C bit to $Ws<Wb>$	1	1	None
		BSW.Z <i>Ws, Wb</i>	Write Z bit to $Ws<Wb>$	1	1	None
9	BTG	BTG <i>f, #bit4</i>	Bit Toggle <i>f</i>	1	1	None
		BTG <i>Ws, #bit4</i>	Bit Toggle <i>Ws</i>	1	1	None

dsPIC33FJ06GS101/X02 and dsPIC33FJ16GSX02/X04

TABLE 22-2: INSTRUCTION SET OVERVIEW (CONTINUED)

Base Instr #	Assembly Mnemonic	Assembly Syntax	Description	# of Words	# of Cycles	Status Flags Affected
10	BTSC	BTSC f, #bit4	Bit Test f, Skip if Clear	1	1 (2 or 3)	None
		BTSC Ws, #bit4	Bit Test Ws, Skip if Clear	1	1 (2 or 3)	None
11	BTSS	BTSS f, #bit4	Bit Test f, Skip if Set	1	1 (2 or 3)	None
		BTSS Ws, #bit4	Bit Test Ws, Skip if Set	1	1 (2 or 3)	None
12	BTST	BTST f, #bit4	Bit Test f	1	1	Z
		BTST.C Ws, #bit4	Bit Test Ws to C	1	1	C
		BTST.Z Ws, #bit4	Bit Test Ws to Z	1	1	Z
		BTST.C Ws, Wb	Bit Test Ws<Wb> to C	1	1	C
		BTST.Z Ws, Wb	Bit Test Ws<Wb> to Z	1	1	Z
13	BTSTS	BTSTS f, #bit4	Bit Test then Set f	1	1	Z
		BTSTS.C Ws, #bit4	Bit Test Ws to C, then Set	1	1	C
		BTSTS.Z Ws, #bit4	Bit Test Ws to Z, then Set	1	1	Z
14	CALL	CALL lit23	Call Subroutine	2	2	None
		CALL Wn	Call Indirect Subroutine	1	2	None
15	CLR	CLR f	f = 0x0000	1	1	None
		CLR WREG	WREG = 0x0000	1	1	None
		CLR Ws	Ws = 0x0000	1	1	None
		CLR Acc, Wx, Wxd, Wy, Wyd, AWB	Clear Accumulator	1	1	OA, OB, SA, SB
16	CLRWDT	CLRWDT	Clear Watchdog Timer	1	1	WDTO, Sleep
17	COM	COM f	f = \bar{f}	1	1	N, Z
		COM f, WREG	WREG = \bar{f}	1	1	N, Z
		COM Ws, Wd	Wd = \bar{Ws}	1	1	N, Z
18	CP	CP f	Compare f with WREG	1	1	C, DC, N, OV, Z
		CP Wb, #lit5	Compare Wb with lit5	1	1	C, DC, N, OV, Z
		CP Wb, Ws	Compare Wb with Ws (Wb - Ws)	1	1	C, DC, N, OV, Z
19	CP0	CP0 f	Compare f with 0x0000	1	1	C, DC, N, OV, Z
		CP0 Ws	Compare Ws with 0x0000	1	1	C, DC, N, OV, Z
20	CPB	CPB f	Compare f with WREG, with Borrow	1	1	C, DC, N, OV, Z
		CPB Wb, #lit5	Compare Wb with lit5, with Borrow	1	1	C, DC, N, OV, Z
		CPB Wb, Ws	Compare Wb with Ws, with Borrow (Wb - Ws - C)	1	1	C, DC, N, OV, Z
21	CPSEQ	CPSEQ Wb, Wn	Compare Wb with Wn, Skip if =	1	1 (2 or 3)	None
22	CPSGT	CPSGT Wb, Wn	Compare Wb with Wn, Skip if >	1	1 (2 or 3)	None
23	CPSLT	CPSLT Wb, Wn	Compare Wb with Wn, Skip if <	1	1 (2 or 3)	None
24	CPSNE	CPSNE Wb, Wn	Compare Wb with Wn, Skip if ≠	1	1 (2 or 3)	None
25	DAW	DAW Wn	Wn = Decimal Adjust Wn	1	1	C
26	DEC	DEC f	f = f - 1	1	1	C, DC, N, OV, Z
		DEC f, WREG	WREG = f - 1	1	1	C, DC, N, OV, Z
		DEC Ws, Wd	Wd = Ws - 1	1	1	C, DC, N, OV, Z
27	DEC2	DEC2 f	f = f - 2	1	1	C, DC, N, OV, Z
		DEC2 f, WREG	WREG = f - 2	1	1	C, DC, N, OV, Z
		DEC2 Ws, Wd	Wd = Ws - 2	1	1	C, DC, N, OV, Z
28	DISI	DISI #lit14	Disable Interrupts for k Instruction Cycles	1	1	None

dsPIC33FJ06GS101/X02 and dsPIC33FJ16GSX02/X04

TABLE 22-2: INSTRUCTION SET OVERVIEW (CONTINUED)

Base Instr #	Assembly Mnemonic	Assembly Syntax	Description	# of Words	# of Cycles	Status Flags Affected
29	DIV	DIV.S Wm, Wn	Signed 16/16-bit Integer Divide	1	18	N,Z,C,OV
		DIV.SD Wm, Wn	Signed 32/16-bit Integer Divide	1	18	N,Z,C,OV
		DIV.U Wm, Wn	Unsigned 16/16-bit Integer Divide	1	18	N,Z,C,OV
		DIV.UD Wm, Wn	Unsigned 32/16-bit Integer Divide	1	18	N,Z,C,OV
30	DIVF	DIVF Wm, Wn	Signed 16/16-bit Fractional Divide	1	18	N,Z,C,OV
31	DO	DO #lit14, Expr	Do code to PC + Expr, lit14 + 1 times	2	2	None
		DO Wn, Expr	Do code to PC + Expr, (Wn) + 1 times	2	2	None
32	ED	ED Wm*Wm, Acc, Wx, Wy, Wxd	Euclidean Distance (no accumulate)	1	1	OA,OB,OAB,SA,SB,SAB
33	EDAC	EDAC Wm*Wm, Acc, Wx, Wy, Wxd	Euclidean Distance	1	1	OA,OB,OAB,SA,SB,SAB
34	EXCH	EXCH Wns, Wnd	Swap Wns with Wnd	1	1	None
35	FBCL	FBCL Ws, Wnd	Find Bit Change from Left (MSb) Side	1	1	C
36	FF1L	FF1L Ws, Wnd	Find First One from Left (MSb) Side	1	1	C
37	FF1R	FF1R Ws, Wnd	Find First One from Right (LSb) Side	1	1	C
38	GOTO	GOTO Expr	Go to Address	2	2	None
		GOTO Wn	Go to Indirect	1	2	None
39	INC	INC f	f = f + 1	1	1	C,DC,N,OV,Z
		INC f, WREG	WREG = f + 1	1	1	C,DC,N,OV,Z
		INC Ws, Wd	Wd = Ws + 1	1	1	C,DC,N,OV,Z
40	INC2	INC2 f	f = f + 2	1	1	C,DC,N,OV,Z
		INC2 f, WREG	WREG = f + 2	1	1	C,DC,N,OV,Z
		INC2 Ws, Wd	Wd = Ws + 2	1	1	C,DC,N,OV,Z
41	IOR	IOR f	f = f .IOR. WREG	1	1	N,Z
		IOR f, WREG	WREG = f .IOR. WREG	1	1	N,Z
		IOR #lit10, Wn	Wd = lit10 .IOR. Wd	1	1	N,Z
		IOR Wb, Ws, Wd	Wd = Wb .IOR. Ws	1	1	N,Z
		IOR Wb, #lit5, Wd	Wd = Wb .IOR. lit5	1	1	N,Z
42	LAC	LAC Wso, #Slit4, Acc	Load Accumulator	1	1	OA,OB,OAB,SA,SB,SAB
43	LNK	LNK #lit14	Link Frame Pointer	1	1	None
44	LSR	LSR f	f = Logical Right Shift f	1	1	C,N,OV,Z
		LSR f, WREG	WREG = Logical Right Shift f	1	1	C,N,OV,Z
		LSR Ws, Wd	Wd = Logical Right Shift Ws	1	1	C,N,OV,Z
		LSR Wb, Wns, Wnd	Wnd = Logical Right Shift Wb by Wns	1	1	N,Z
		LSR Wb, #lit5, Wnd	Wnd = Logical Right Shift Wb by lit5	1	1	N,Z
45	MAC	MAC Wm*Wn, Acc, Wx, Wxd, Wy, Wyd, AWB	Multiply and Accumulate	1	1	OA,OB,OAB,SA,SB,SAB
		MAC Wm*Wm, Acc, Wx, Wxd, Wy, Wyd	Square and Accumulate	1	1	OA,OB,OAB,SA,SB,SAB
46	MOV	MOV f, Wn	Move f to Wn	1	1	None
		MOV f	Move f to f	1	1	N,Z
		MOV f, WREG	Move f to WREG	1	1	None
		MOV #lit16, Wn	Move 16-bit Literal to Wn	1	1	None
		MOV.b #lit8, Wn	Move 8-bit Literal to Wn	1	1	None
		MOV Wn, f	Move Wn to f	1	1	None
		MOV Wso, Wdo	Move Ws to Wd	1	1	None
		MOV WREG, f	Move WREG to f	1	1	None
		MOV.D Wns, Wd	Move Double from W(ns):W(ns + 1) to Wd	1	2	None
MOV.D Ws, Wnd	Move Double from Ws to W(nd + 1):W(nd)	1	2	None		
47	MOVSAC	MOVSAC Acc, Wx, Wxd, Wy, Wyd, AWB	Prefetch and Store Accumulator	1	1	None

dsPIC33FJ06GS101/X02 and dsPIC33FJ16GSX02/X04

TABLE 22-2: INSTRUCTION SET OVERVIEW (CONTINUED)

Base Instr #	Assembly Mnemonic	Assembly Syntax	Description	# of Words	# of Cycles	Status Flags Affected
48	MPY	MPY Wm*Wn, Acc, Wx, Wxd, Wy, Wyd	Multiply Wm by Wn to Accumulator	1	1	OA,OB,OAB,SA,SB,SAB
		MPY Wm*Wm, Acc, Wx, Wxd, Wy, Wyd	Square Wm to Accumulator	1	1	OA,OB,OAB,SA,SB,SAB
49	MPY.N	MPY.N Wm*Wn, Acc, Wx, Wxd, Wy, Wyd	-(Multiply Wm by Wn) to Accumulator	1	1	None
50	MSC	MSC Wm*Wm, Acc, Wx, Wxd, Wy, Wyd AWB	Multiply and Subtract from Accumulator	1	1	OA,OB,OAB,SA,SB,SAB
51	MUL	MUL.SS Wb, Ws, Wnd	{Wnd + 1, Wnd} = signed(Wb) * signed(Ws)	1	1	None
		MUL.SU Wb, Ws, Wnd	{Wnd + 1, Wnd} = signed(Wb) * unsigned(Ws)	1	1	None
		MUL.US Wb, Ws, Wnd	{Wnd + 1, Wnd} = unsigned(Wb) * signed(Ws)	1	1	None
		MUL.UU Wb, Ws, Wnd	{Wnd + 1, Wnd} = unsigned(Wb) * unsigned(Ws)	1	1	None
		MUL.SU Wb, #lit5, Wnd	{Wnd + 1, Wnd} = signed(Wb) * unsigned(lit5)	1	1	None
		MUL.UU Wb, #lit5, Wnd	{Wnd + 1, Wnd} = unsigned(Wb) * unsigned(lit5)	1	1	None
		MUL f	W3:W2 = f * WREG	1	1	None
52	NEG	NEG Acc	Negate Accumulator	1	1	OA,OB,OAB,SA,SB,SAB
		NEG f	$f = \bar{f} + 1$	1	1	C,DC,N,OV,Z
		NEG f, WREG	WREG = $\bar{f} + 1$	1	1	C,DC,N,OV,Z
		NEG Ws, Wd	$Wd = \overline{Ws} + 1$	1	1	C,DC,N,OV,Z
53	NOP	NOP	No Operation	1	1	None
		NOPR	No Operation	1	1	None
54	POP	POP f	Pop f from Top-of-Stack (TOS)	1	1	None
		POP Wdo	Pop from Top-of-Stack (TOS) to Wdo	1	1	None
		POP.D Wnd	Pop from Top-of-Stack (TOS) to W(nd):W(nd + 1)	1	2	None
		POP.S	Pop Shadow Registers	1	1	All
55	PUSH	PUSH f	Push f to Top-of-Stack (TOS)	1	1	None
		PUSH Wso	Push Wso to Top-of-Stack (TOS)	1	1	None
		PUSH.D Wns	Push W(ns):W(ns + 1) to Top-of-Stack (TOS)	1	2	None
		PUSH.S	Push Shadow Registers	1	1	None
56	PWRSVAV	PWRSVAV #lit1	Go into Sleep or Idle mode	1	1	WDTO,Sleep
57	RCALL	RCALL Expr	Relative Call	1	2	None
		RCALL Wn	Computed Call	1	2	None
58	REPEAT	REPEAT #lit14	Repeat Next Instruction lit14 + 1 times	1	1	None
		REPEAT Wn	Repeat Next Instruction (Wn) + 1 times	1	1	None
59	RESET	RESET	Software Device Reset	1	1	None
60	RETFIE	RETFIE	Return from interrupt	1	3 (2)	None
61	RETLW	RETLW #lit10, Wn	Return with Literal in Wn	1	3 (2)	None
62	RETURN	RETURN	Return from Subroutine	1	3 (2)	None
63	RLC	RLC f	f = Rotate Left through Carry f	1	1	C,N,Z
		RLC f, WREG	WREG = Rotate Left through Carry f	1	1	C,N,Z
		RLC Ws, Wd	Wd = Rotate Left through Carry Ws	1	1	C,N,Z
64	RLNC	RLNC f	f = Rotate Left (No Carry) f	1	1	N,Z
		RLNC f, WREG	WREG = Rotate Left (No Carry) f	1	1	N,Z
		RLNC Ws, Wd	Wd = Rotate Left (No Carry) Ws	1	1	N,Z
65	RRC	RRC f	f = Rotate Right through Carry f	1	1	C,N,Z
		RRC f, WREG	WREG = Rotate Right through Carry f	1	1	C,N,Z
		RRC Ws, Wd	Wd = Rotate Right through Carry Ws	1	1	C,N,Z

dsPIC33FJ06GS101/X02 and dsPIC33FJ16GSX02/X04

TABLE 22-2: INSTRUCTION SET OVERVIEW (CONTINUED)

Base Instr #	Assembly Mnemonic	Assembly Syntax	Description	# of Words	# of Cycles	Status Flags Affected
66	RRNC	RRNC f	f = Rotate Right (No Carry) f	1	1	N,Z
		RRNC f, WREG	WREG = Rotate Right (No Carry) f	1	1	N,Z
		RRNC Ws, Wd	Wd = Rotate Right (No Carry) Ws	1	1	N,Z
67	SAC	SAC Acc, #Slit4, Wdo	Store Accumulator	1	1	None
		SAC.R Acc, #Slit4, Wdo	Store Rounded Accumulator	1	1	None
68	SE	SE Ws, Wnd	Wnd = Sign-Extended Ws	1	1	C,N,Z
69	SETM	SETM f	f = 0xFFFF	1	1	None
		SETM WREG	WREG = 0xFFFF	1	1	None
		SETM Ws	Ws = 0xFFFF	1	1	None
70	SFTAC	SFTAC Acc, Wn	Arithmetic Shift Accumulator by (Wn)	1	1	OA,OB,OAB,SA,SB,SAB
		SFTAC Acc, #Slit6	Arithmetic Shift Accumulator by Slit6	1	1	OA,OB,OAB,SA,SB,SAB
71	SL	SL f	f = Left Shift f	1	1	C,N,OV,Z
		SL f, WREG	WREG = Left Shift f	1	1	C,N,OV,Z
		SL Ws, Wd	Wd = Left Shift Ws	1	1	C,N,OV,Z
		SL Wb, Wns, Wnd	Wnd = Left Shift Wb by Wns	1	1	N,Z
		SL Wb, #lit5, Wnd	Wnd = Left Shift Wb by lit5	1	1	N,Z
72	SUB	SUB Acc	Subtract Accumulators	1	1	OA,OB,OAB,SA,SB,SAB
		SUB f	f = f - WREG	1	1	C,DC,N,OV,Z
		SUB f, WREG	WREG = f - WREG	1	1	C,DC,N,OV,Z
		SUB #lit10, Wn	Wn = Wn - lit10	1	1	C,DC,N,OV,Z
		SUB Wb, Ws, Wd	Wd = Wb - Ws	1	1	C,DC,N,OV,Z
		SUB Wb, #lit5, Wd	Wd = Wb - lit5	1	1	C,DC,N,OV,Z
73	SUBB	SUBB f	f = f - WREG - (\bar{C})	1	1	C,DC,N,OV,Z
		SUBB f, WREG	WREG = f - WREG - (\bar{C})	1	1	C,DC,N,OV,Z
		SUBB #lit10, Wn	Wn = Wn - lit10 - (\bar{C})	1	1	C,DC,N,OV,Z
		SUBB Wb, Ws, Wd	Wd = Wb - Ws - (\bar{C})	1	1	C,DC,N,OV,Z
		SUBB Wb, #lit5, Wd	Wd = Wb - lit5 - (\bar{C})	1	1	C,DC,N,OV,Z
74	SUBR	SUBR f	f = WREG - f	1	1	C,DC,N,OV,Z
		SUBR f, WREG	WREG = WREG - f	1	1	C,DC,N,OV,Z
		SUBR Wb, Ws, Wd	Wd = Ws - Wb	1	1	C,DC,N,OV,Z
		SUBR Wb, #lit5, Wd	Wd = lit5 - Wb	1	1	C,DC,N,OV,Z
75	SUBBR	SUBBR f	f = WREG - f - (\bar{C})	1	1	C,DC,N,OV,Z
		SUBBR f, WREG	WREG = WREG - f - (\bar{C})	1	1	C,DC,N,OV,Z
		SUBBR Wb, Ws, Wd	Wd = Ws - Wb - (\bar{C})	1	1	C,DC,N,OV,Z
		SUBBR Wb, #lit5, Wd	Wd = lit5 - Wb - (\bar{C})	1	1	C,DC,N,OV,Z
76	SWAP	SWAP.b Wn	Wn = Nibble Swap Wn	1	1	None
		SWAP Wn	Wn = Byte Swap Wn	1	1	None
77	TBLRDH	TBLRDH Ws, Wd	Read Prog<23:16> to Wd<7:0>	1	2	None
78	TBLRDL	TBLRDL Ws, Wd	Read Prog<15:0> to Wd	1	2	None
79	TBLWTH	TBLWTH Ws, Wd	Write Ws<7:0> to Prog<23:16>	1	2	None
80	TBLWTL	TBLWTL Ws, Wd	Write Ws to Prog<15:0>	1	2	None
81	ULNK	ULNK	Unlink Frame Pointer	1	1	None
82	XOR	XOR f	f = f .XOR. WREG	1	1	N,Z
		XOR f, WREG	WREG = f .XOR. WREG	1	1	N,Z
		XOR #lit10, Wn	Wd = lit10 .XOR. Wd	1	1	N,Z
		XOR Wb, Ws, Wd	Wd = Wb .XOR. Ws	1	1	N,Z
		XOR Wb, #lit5, Wd	Wd = Wb .XOR. lit5	1	1	N,Z
83	ZE	ZE Ws, Wnd	Wnd = Zero-Extend Ws	1	1	C,Z,N

23.0 DEVELOPMENT SUPPORT

The PIC® microcontrollers (MCU) and dsPIC® Digital Signal Controllers (DSC) are supported with a full range of software and hardware development tools:

- Integrated Development Environment
 - MPLAB® X IDE Software
- Compilers/Assemblers/Linkers
 - MPLAB XC Compiler
 - MPASM™ Assembler
 - MPLINK™ Object Linker/
MPLIB™ Object Librarian
 - MPLAB Assembler/Linker/Librarian for
Various Device Families
- Simulators
 - MPLAB X SIM Software Simulator
- Emulators
 - MPLAB REAL ICE™ In-Circuit Emulator
- In-Circuit Debuggers/Programmers
 - MPLAB ICD 3
 - PICKit™ 3
- Device Programmers
 - MPLAB PM3 Device Programmer
- Low-Cost Demonstration/Development Boards,
Evaluation Kits and Starter Kits
- Third-party development tools

23.1 MPLAB X Integrated Development Environment Software

The MPLAB X IDE is a single, unified graphical user interface for Microchip and third-party software, and hardware development tool that runs on Windows®, Linux and Mac OS® X. Based on the NetBeans IDE, MPLAB X IDE is an entirely new IDE with a host of free software components and plug-ins for high-performance application development and debugging. Moving between tools and upgrading from software simulators to hardware debugging and programming tools is simple with the seamless user interface.

With complete project management, visual call graphs, a configurable watch window and a feature-rich editor that includes code completion and context menus, MPLAB X IDE is flexible and friendly enough for new users. With the ability to support multiple tools on multiple projects with simultaneous debugging, MPLAB X IDE is also suitable for the needs of experienced users.

Feature-Rich Editor:

- Color syntax highlighting
- Smart code completion makes suggestions and provides hints as you type
- Automatic code formatting based on user-defined rules
- Live parsing

User-Friendly, Customizable Interface:

- Fully customizable interface: toolbars, toolbar buttons, windows, window placement, etc.
- Call graph window

Project-Based Workspaces:

- Multiple projects
- Multiple tools
- Multiple configurations
- Simultaneous debugging sessions

File History and Bug Tracking:

- Local file history feature
- Built-in support for Bugzilla issue tracker

23.2 MPLAB XC Compilers

The MPLAB XC Compilers are complete ANSI C compilers for all of Microchip's 8, 16 and 32-bit MCU and DSC devices. These compilers provide powerful integration capabilities, superior code optimization and ease of use. MPLAB XC Compilers run on Windows, Linux or MAC OS X.

For easy source level debugging, the compilers provide debug information that is optimized to the MPLAB X IDE.

The free MPLAB XC Compiler editions support all devices and commands, with no time or memory restrictions, and offer sufficient code optimization for most applications.

MPLAB XC Compilers include an assembler, linker and utilities. The assembler generates relocatable object files that can then be archived or linked with other relocatable object files and archives to create an executable file. MPLAB XC Compiler uses the assembler to produce its object file. Notable features of the assembler include:

- Support for the entire device instruction set
- Support for fixed-point and floating-point data
- Command-line interface
- Rich directive set
- Flexible macro language
- MPLAB X IDE compatibility

23.3 MPASM Assembler

The MPASM Assembler is a full-featured, universal macro assembler for PIC10/12/16/18 MCUs.

The MPASM Assembler generates relocatable object files for the MPLINK Object Linker, Intel® standard HEX files, MAP files to detail memory usage and symbol reference, absolute LST files that contain source lines and generated machine code, and COFF files for debugging.

The MPASM Assembler features include:

- Integration into MPLAB X IDE projects
- User-defined macros to streamline assembly code
- Conditional assembly for multipurpose source files
- Directives that allow complete control over the assembly process

23.4 MPLINK Object Linker/ MPLIB Object Librarian

The MPLINK Object Linker combines relocatable objects created by the MPASM Assembler. It can link relocatable objects from precompiled libraries, using directives from a linker script.

The MPLIB Object Librarian manages the creation and modification of library files of precompiled code. When a routine from a library is called from a source file, only the modules that contain that routine will be linked in with the application. This allows large libraries to be used efficiently in many different applications.

The object linker/library features include:

- Efficient linking of single libraries instead of many smaller files
- Enhanced code maintainability by grouping related modules together
- Flexible creation of libraries with easy module listing, replacement, deletion and extraction

23.5 MPLAB Assembler, Linker and Librarian for Various Device Families

MPLAB Assembler produces relocatable machine code from symbolic assembly language for PIC24, PIC32 and dsPIC DSC devices. MPLAB XC Compiler uses the assembler to produce its object file. The assembler generates relocatable object files that can then be archived or linked with other relocatable object files and archives to create an executable file. Notable features of the assembler include:

- Support for the entire device instruction set
- Support for fixed-point and floating-point data
- Command-line interface
- Rich directive set
- Flexible macro language
- MPLAB X IDE compatibility

23.6 MPLAB X SIM Software Simulator

The MPLAB X SIM Software Simulator allows code development in a PC-hosted environment by simulating the PIC MCUs and dsPIC DSCs on an instruction level. On any given instruction, the data areas can be examined or modified and stimuli can be applied from a comprehensive stimulus controller. Registers can be logged to files for further run-time analysis. The trace buffer and logic analyzer display extend the power of the simulator to record and track program execution, actions on I/O, most peripherals and internal registers.

The MPLAB X SIM Software Simulator fully supports symbolic debugging using the MPLAB XC Compilers, and the MPASM and MPLAB Assemblers. The software simulator offers the flexibility to develop and debug code outside of the hardware laboratory environment, making it an excellent, economical software development tool.

23.7 MPLAB REAL ICE In-Circuit Emulator System

The MPLAB REAL ICE In-Circuit Emulator System is Microchip's next generation high-speed emulator for Microchip Flash DSC and MCU devices. It debugs and programs all 8, 16 and 32-bit MCU, and DSC devices with the easy-to-use, powerful graphical user interface of the MPLAB X IDE.

The emulator is connected to the design engineer's PC using a high-speed USB 2.0 interface and is connected to the target with either a connector compatible with in-circuit debugger systems (RJ-11) or with the new high-speed, noise tolerant, Low-Voltage Differential Signal (LVDS) interconnection (CAT5).

The emulator is field upgradable through future firmware downloads in MPLAB X IDE. MPLAB REAL ICE offers significant advantages over competitive emulators including full-speed emulation, run-time variable watches, trace analysis, complex breakpoints, logic probes, a ruggedized probe interface and long (up to three meters) interconnection cables.

23.8 MPLAB ICD 3 In-Circuit Debugger System

The MPLAB ICD 3 In-Circuit Debugger System is Microchip's most cost-effective, high-speed hardware debugger/programmer for Microchip Flash DSC and MCU devices. It debugs and programs PIC Flash microcontrollers and dsPIC DSCs with the powerful, yet easy-to-use graphical user interface of the MPLAB IDE.

The MPLAB ICD 3 In-Circuit Debugger probe is connected to the design engineer's PC using a high-speed USB 2.0 interface and is connected to the target with a connector compatible with the MPLAB ICD 2 or MPLAB REAL ICE systems (RJ-11). MPLAB ICD 3 supports all MPLAB ICD 2 headers.

23.9 PICkit 3 In-Circuit Debugger/Programmer

The MPLAB PICkit 3 allows debugging and programming of PIC and dsPIC Flash microcontrollers at a most affordable price point using the powerful graphical user interface of the MPLAB IDE. The MPLAB PICkit 3 is connected to the design engineer's PC using a full-speed USB interface and can be connected to the target via a Microchip debug (RJ-11) connector (compatible with MPLAB ICD 3 and MPLAB REAL ICE). The connector uses two device I/O pins and the Reset line to implement in-circuit debugging and In-Circuit Serial Programming™ (ICSP™).

23.10 MPLAB PM3 Device Programmer

The MPLAB PM3 Device Programmer is a universal, CE compliant device programmer with programmable voltage verification at VDDMIN and VDDMAX for maximum reliability. It features a large LCD display (128 x 64) for menus and error messages, and a modular, detachable socket assembly to support various package types. The ICSP cable assembly is included as a standard item. In Stand-Alone mode, the MPLAB PM3 Device Programmer can read, verify and program PIC devices without a PC connection. It can also set code protection in this mode. The MPLAB PM3 connects to the host PC via an RS-232 or USB cable. The MPLAB PM3 has high-speed communications and optimized algorithms for quick programming of large memory devices, and incorporates an MMC card for file storage and data applications.

23.11 Demonstration/Development Boards, Evaluation Kits and Starter Kits

A wide variety of demonstration, development and evaluation boards for various PIC MCUs and dsPIC DSCs allows quick application development on fully functional systems. Most boards include prototyping areas for adding custom circuitry and provide application firmware and source code for examination and modification.

The boards support a variety of features, including LEDs, temperature sensors, switches, speakers, RS-232 interfaces, LCD displays, potentiometers and additional EEPROM memory.

The demonstration and development boards can be used in teaching environments, for prototyping custom circuits and for learning about various microcontroller applications.

In addition to the PICDEM™ and dsPICDEM™ demonstration/development board series of circuits, Microchip has a line of evaluation kits and demonstration software for analog filter design, KEELOQ® security ICs, CAN, IrDA®, PowerSmart battery management, SEEVAL® evaluation system, Sigma-Delta ADC, flow rate sensing, plus many more.

Also available are starter kits that contain everything needed to experience the specified device. This usually includes a single application and debug capability, all on one board.

Check the Microchip web page (www.microchip.com) for the complete list of demonstration, development and evaluation kits.

23.12 Third-Party Development Tools

Microchip also offers a great collection of tools from third-party vendors. These tools are carefully selected to offer good value and unique functionality.

- Device Programmers and Gang Programmers from companies, such as SoftLog and CCS
- Software Tools from companies, such as Gimpel and Trace Systems
- Protocol Analyzers from companies, such as Saleae and Total Phase
- Demonstration Boards from companies, such as MikroElektronika, Digilent® and Olimex
- Embedded Ethernet Solutions from companies, such as EZ Web Lynx, WIZnet and IPLogika®

dsPIC33FJ06GS101/X02 and dsPIC33FJ16GSX02/X04

24.0 ELECTRICAL CHARACTERISTICS

This section provides an overview of dsPIC33FJ06GS101/X02 and dsPIC33FJ16GSX02/X04 electrical characteristics. Additional information will be provided in future revisions of this document as it becomes available.

Absolute maximum ratings for the dsPIC33FJ06GS101/X02 and dsPIC33FJ16GSX02/X04 family are listed below. Exposure to these maximum rating conditions for extended periods may affect device reliability. Functional operation of the device at these or any other conditions above the parameters indicated in the operation listings of this specification is not implied.

Absolute Maximum Ratings⁽¹⁾

Ambient temperature under bias	-40°C to +125°C
Storage temperature	-65°C to +150°C
Voltage on VDD with respect to VSS	-0.3V to +4.0V
Voltage on any pin that is not 5V tolerant, with respect to VSS ⁽³⁾	-0.3V to (VDD + 0.3V)
Voltage on any 5V tolerant pin with respect to VSS, when VDD ≥ 3.0V ⁽³⁾	-0.3V to +5.6V
Voltage on any 5V tolerant pin with respect to VSS, when VDD < 3.0V ⁽³⁾	-0.3V to (VDD + 0.3V)
Maximum current out of VSS pin	300 mA
Maximum current into VDD pin ⁽²⁾	250 mA
Maximum current sourced/sunk by any 4x I/O pin	15 mA
Maximum current sourced/sunk by any 8x I/O pin	25 mA
Maximum current sourced/sunk by any 16x I/O pin	45 mA
Maximum current sunk by all ports	200 mA
Maximum current sourced by all ports ⁽²⁾	200mA

Note 1: Stresses above those listed under “Absolute Maximum Ratings” may cause permanent damage to the device. This is a stress rating only, and functional operation of the device at those or any other conditions above those indicated in the operation listings of this specification is not implied. Exposure to maximum rating conditions for extended periods may affect device reliability.

2: Maximum allowable current is a function of device maximum power dissipation (see [Table 24-2](#)).

3: See the “[Pin Diagrams](#)” section for 5V tolerant pins.

dsPIC33FJ06GS101/X02 and dsPIC33FJ16GSX02/X04

24.1 DC Characteristics

TABLE 24-1: OPERATING MIPS VS. VOLTAGE

Characteristic	VDD Range (in Volts)	Temp Range (in °C)	Max MIPS
			dsPIC33FJ06GS101/X02 and dsPIC33FJ16GSX02/X04
—	3.0-3.6V ⁽¹⁾	-40°C to +85°C	40
—	3.0-3.6V ⁽¹⁾	-40°C to +125°C	40

Note 1: Overall functional device operation at $V_{BORMIN} < V_{DD} < V_{DDMIN}$ is tested but not characterized. All device analog modules such as the ADC, etc., will function but with degraded performance below V_{DDMIN} . Refer to Parameter [BO10](#) in [Table 24-11](#) for BOR values.

TABLE 24-2: THERMAL OPERATING CONDITIONS

Rating	Symbol	Min	Typ	Max	Unit
Industrial Temperature Devices					
Operating Junction Temperature Range	TJ	-40	—	+125	°C
Operating Ambient Temperature Range	TA	-40	—	+85	°C
Extended Temperature Devices					
Operating Junction Temperature Range	TJ	-40	—	+140	°C
Operating Ambient Temperature Range	TA	-40	—	+125	°C
Power Dissipation: Internal chip power dissipation: $P_{INT} = V_{DD} \times (I_{DD} - \Sigma I_{OH})$ I/O Pin Power Dissipation: $I/O = \Sigma (\{V_{DD} - V_{OH}\} \times I_{OH}) + \Sigma (V_{OL} \times I_{OL})$	PD	PINT + PI/O			W
Maximum Allowed Power Dissipation	PDMAX	$(T_J - T_A)/\theta_{JA}$			W

TABLE 24-3: THERMAL PACKAGING CHARACTERISTICS

Characteristic	Symbol	Typ	Max	Unit	Notes
Package Thermal Resistance, 44-Pin QFN	θ_{JA}	28	—	°C/W	1
Package Thermal Resistance, 44-Pin TFQP	θ_{JA}	39	—	°C/W	1
Package Thermal Resistance, 28-Pin SPDIP	θ_{JA}	42	—	°C/W	1
Package Thermal Resistance, 28-Pin SOIC	θ_{JA}	47	—	°C/W	1
Package Thermal Resistance, 28-Pin QFN-S	θ_{JA}	34	—	°C/W	1
Package Thermal Resistance, 18-Pin SOIC	θ_{JA}	57	—	°C/W	1
Package Thermal Resistance, 44-Pin VTLA	θ_{JA}	25	—	°C/W	1

Note 1: Junction to ambient thermal resistance, Theta-JA (θ_{JA}) numbers are achieved by package simulations.

dsPIC33FJ06GS101/X02 and dsPIC33FJ16GSX02/X04

TABLE 24-4: DC TEMPERATURE AND VOLTAGE SPECIFICATIONS

DC CHARACTERISTICS			Standard Operating Conditions: 3.0V to 3.6V (unless otherwise stated) Operating temperature -40°C ≤ TA ≤ +85°C for Industrial -40°C ≤ TA ≤ +125°C for Extended				
Param No.	Symbol	Characteristic	Min	Typ ⁽¹⁾	Max	Units	Conditions
Operating Voltage							
DC10	VDD	Supply Voltage ⁽⁴⁾	3.0	—	3.6	V	Industrial and Extended
DC12	VDR	RAM Data Retention Voltage ⁽²⁾	1.8	—	—	V	
DC16	VPOR	VDD Start Voltage to Ensure Internal Power-on Reset Signal	—	—	VSS	V	
DC17	SVDD	VDD Rise Rate ⁽³⁾ to Ensure Internal Power-on Reset Signal	0.03	—	—	V/ms	0V-3.0V in 0.1 seconds

- Note 1:** Data in “Typ” column is at 3.3V, +25°C unless otherwise stated.
- 2:** This is the limit to which VDD may be lowered without losing RAM data.
- 3:** These parameters are characterized but not tested in manufacturing.
- 4:** Overall functional device operation at VBORMIN < VDD < VDDMIN is tested but not characterized. All device analog modules such as the ADC, etc., will function but with degraded performance below VDDMIN. Refer to Parameter [BO10](#) in [Table 24-11](#) for BOR values.

dsPIC33FJ06GS101/X02 and dsPIC33FJ16GSX02/X04

TABLE 24-5: DC CHARACTERISTICS: OPERATING CURRENT (IDD)

DC CHARACTERISTICS			Standard Operating Conditions: 3.0V to 3.6V (unless otherwise stated) Operating temperature -40°C ≤ TA ≤ +85°C for Industrial -40°C ≤ TA ≤ +125°C for Extended			
Parameter No.	Typical ⁽¹⁾	Max	Units	Conditions		
Operating Current (IDD)⁽²⁾						
DC20d	55	70	mA	-40°C	3.3V 10 MIPS See Note 2	
DC20a	55	70	mA	+25°C		
DC20b	55	70	mA	+85°C		
DC20c	55	70	mA	+125°C		
DC21d	68	85	mA	-40°C	3.3V 16 MIPS See Note 2 and Note 3	
DC21a	68	85	mA	+25°C		
DC21b	68	85	mA	+85°C		
DC21c	68	85	mA	+125°C		
DC22d	78	95	mA	-40°C	3.3V 20 MIPS See Note 2 and Note 3	
DC22a	78	95	mA	+25°C		
DC22b	78	95	mA	+85°C		
DC22c	78	95	mA	+125°C		
DC23d	88	110	mA	-40°C	3.3V 30 MIPS See Note 2 and Note 3	
DC23a	88	110	mA	+25°C		
DC23b	88	110	mA	+85°C		
DC23c	88	110	mA	+125°C		
DC24d	98	120	mA	-40°C	3.3V 40 MIPS See Note 2	
DC24a	98	120	mA	+25°C		
DC24b	98	120	mA	+85°C		
DC24c	98	120	mA	+125°C		
DC25d	128	160	mA	-40°C	3.3V 40 MIPS See Note 2 , except PWM is operating at maximum speed (PTCON2 = 0x0000)	
DC25a	125	150	mA	+25°C		
DC25b	121	150	mA	+85°C		
DC25c	119	150	mA	+125°C		
DC26d	115	140	mA	-40°C	3.3V 40 MIPS See Note 2 , except PWM is operating at 1/2 speed (PTCON2 = 0x0001)	
DC26a	112	140	mA	+25°C		
DC26b	110	140	mA	+85°C		
DC26c	108	140	mA	+125°C		

Note 1: Data in "Typical" column is at 3.3V, +25°C unless otherwise stated.

2: IDD is primarily a function of the operating voltage and frequency. Other factors, such as I/O pin loading and switching rate, oscillator type, internal code execution pattern and temperature, also have an impact on the current consumption. The test conditions for all IDD measurements are as follows:

- Oscillator is configured in EC mode with PLL, OSC1 is driven with external square wave from rail-to-rail (EC clock overshoot/undershoot < 250 mV required)
- CLKO is configured as an I/O input pin in the Configuration Word
- All I/O pins are configured as inputs and pulled to Vss
- MCLR = VDD, WDT and FSCM are disabled
- CPU, SRAM, program memory and data memory are operational
- No peripheral modules are operating; however, every peripheral is being clocked (all PMDx bits are zeroed)
- CPU executing `while(1)` statement
- JTAG disabled

3: These parameters are characterized but not tested in manufacturing.

dsPIC33FJ06GS101/X02 and dsPIC33FJ16GSX02/X04

TABLE 24-5: DC CHARACTERISTICS: OPERATING CURRENT (IDD) (CONTINUED)

DC CHARACTERISTICS			Standard Operating Conditions: 3.0V to 3.6V (unless otherwise stated) Operating temperature -40°C ≤ TA ≤ +85°C for Industrial -40°C ≤ TA ≤ +125°C for Extended		
Parameter No.	Typical ⁽¹⁾	Max	Units	Conditions	
Operating Current (IDD)⁽²⁾					
DC27d	111	140	mA	-40°C	3.3V 40 MIPS See Note 2 , except PWM is operating at 1/4 speed (PTCON2 = 0x0002)
DC27a	108	130	mA	+25°C	
DC27b	105	130	mA	+85°C	
DC27c	103	130	mA	+125°C	
DC28d	102	130	mA	-40°C	3.3V 40 MIPS See Note 2 , except PWM is operating at 1/8 speed (PTCON2 = 0x0003)
DC28a	100	120	mA	+25°C	
DC28b	100	120	mA	+85°C	
DC28c	100	120	mA	+125°C	

Note 1: Data in “Typical” column is at 3.3V, +25°C unless otherwise stated.

2: IDD is primarily a function of the operating voltage and frequency. Other factors, such as I/O pin loading and switching rate, oscillator type, internal code execution pattern and temperature, also have an impact on the current consumption. The test conditions for all IDD measurements are as follows:

- Oscillator is configured in EC mode with PLL, OSC1 is driven with external square wave from rail-to-rail (EC clock overshoot/undershoot < 250 mV required)
- CLKO is configured as an I/O input pin in the Configuration Word
- All I/O pins are configured as inputs and pulled to VSS
- MCLR = VDD, WDT and FSCM are disabled
- CPU, SRAM, program memory and data memory are operational
- No peripheral modules are operating; however, every peripheral is being clocked (all PMDx bits are zeroed)
- CPU executing `while(1)` statement
- JTAG disabled

3: These parameters are characterized but not tested in manufacturing.

dsPIC33FJ06GS101/X02 and dsPIC33FJ16GSX02/X04

TABLE 24-6: DC CHARACTERISTICS: IDLE CURRENT (I_{IDLE})

DC CHARACTERISTICS			Standard Operating Conditions: 3.0V to 3.6V (unless otherwise stated) Operating temperature -40°C ≤ T _A ≤ +85°C for Industrial -40°C ≤ T _A ≤ +125°C for Extended		
Parameter No.	Typical ⁽¹⁾	Max	Units	Conditions	
Idle Current (I_{IDLE}): Core Off Clock On Base Current⁽²⁾					
DC40d	48	—	mA	-40°C	3.3V 10 MIPS
DC40a	48	—	mA	+25°C	
DC40b	48	—	mA	+85°C	
DC40c	48	—	mA	+125°C	
DC41d	60	—	mA	-40°C	3.3V 16 MIPS ⁽³⁾
DC41a	60	—	mA	+25°C	
DC41b	60	—	mA	+85°C	
DC41c	60	—	mA	+125°C	
DC42d	68	—	mA	-40°C	3.3V 20 MIPS ⁽³⁾
DC42a	68	—	mA	+25°C	
DC42b	68	—	mA	+85°C	
DC42c	68	—	mA	+125°C	
DC43d	77	—	mA	-40°C	3.3V 30 MIPS ⁽³⁾
DC43a	77	—	mA	+25°C	
DC43b	77	—	mA	+85°C	
DC43c	77	—	mA	+125°C	
DC44d	86	—	mA	-40°C	3.3V 40 MIPS
DC44a	86	—	mA	+25°C	
DC44b	86	—	mA	+85°C	
DC44c	86	—	mA	+125°C	

Note 1: Data in “Typical” column is at 3.3V, +25°C unless otherwise stated.

2: Base Idle current (I_{IDLE}) is measured as follows:

- CPU core is off, oscillator is configured in EC mode and external clock is active, OSC1 is driven with external square wave from rail-to-rail (EC clock overshoot/undershoot < 250 mV required)
- CLKO is configured as an I/O input pin in the Configuration Word
- All I/O pins are configured as inputs and pulled to V_{SS}
- MCLR = V_{DD}, WDT and FSCM are disabled
- No peripheral modules are operating; however, every peripheral is being clocked (all PMD_x bits are zeroed)
- JTAG is disabled

3: These parameters are characterized but not tested in manufacturing.

dsPIC33FJ06GS101/X02 and dsPIC33FJ16GSX02/X04

TABLE 24-7: DC CHARACTERISTICS: POWER-DOWN CURRENT (IPD)

DC CHARACTERISTICS			Standard Operating Conditions: 3.0V to 3.6V (unless otherwise stated) Operating temperature -40°C ≤ TA ≤ +85°C for Industrial -40°C ≤ TA ≤ +125°C for Extended		
Parameter No.	Typical ⁽¹⁾	Max	Units	Conditions	
Power-Down Current (IPD)^(2,4)					
DC60d	125	500	μA	-40°C	3.3V Base Power-Down Current
DC60a	135	500	μA	+25°C	
DC60b	235	500	μA	+85°C	
DC60c	565	950	μA	+125°C	
DC61d	40	50	μA	-40°C	3.3V Watchdog Timer Current: ΔI _{WDT} ⁽³⁾
DC61a	40	50	μA	+25°C	
DC61b	40	50	μA	+85°C	
DC61c	80	90	μA	+125°C	

Note 1: Data in the Typical column is at 3.3V, +25°C unless otherwise stated.

2: IPD (Sleep) current is measured as follows:

- CPU core is off, oscillator is configured in EC mode and external clock active, OSC1 is driven with external square wave from rail-to-rail (EC clock overshoot/undershoot < 250 mV required)
- CLKO is configured as an I/O input pin in the Configuration Word
- All I/O pins are configured as inputs and pulled to V_{SS}
- MCLR = V_{DD}, WDT and FSCM are disabled
- All peripheral modules are disabled (PMDx bits are all ones)
- The VREGS bit (RCON<8>) = 0 (i.e., core regulator is set to stand-by while the device is in Sleep mode)
- JTAG disabled

3: The Δ current is the additional current consumed when the WDT module is enabled. This current should be added to the base IPD current.

4: These currents are measured on the device containing the most memory in this family.

dsPIC33FJ06GS101/X02 and dsPIC33FJ16GSX02/X04

TABLE 24-8: DC CHARACTERISTICS: DOZE CURRENT (IDOZE)

DC CHARACTERISTICS			Standard Operating Conditions: 3.0V to 3.6V (unless otherwise stated) Operating temperature -40°C ≤ TA ≤ +85°C for Industrial -40°C ≤ TA ≤ +125°C for Extended				
Parameter No.	Typical ⁽¹⁾	Max	Doze Ratio	Units	Conditions		
Doze Current (IDOZE)⁽²⁾							
DC73a	75	105	1:2	mA	-40°C	3.3V	40 MIPS
DC73f	60	105	1:64	mA			
DC73g	60	105	1:128	mA			
DC70a	75	105	1:2	mA	+25°C	3.3V	40 MIPS
DC70f	60	105	1:64	mA			
DC70g	60	105	1:128	mA			
DC71a	75	105	1:2	mA	+85°C	3.3V	40 MIPS
DC71f	60	105	1:64	mA			
DC71g	60	105	1:128	mA			
DC72a	75	105	1:2	mA	+125°C	3.3V	40 MIPS
DC72f	60	105	1:64	mA			
DC72g	60	105	1:128	mA			

Note 1: Data in the Typical column is at 3.3V, +25°C unless otherwise stated.

2: IDOZE is primarily a function of the operating voltage and frequency. Other factors, such as I/O pin loading and switching rate, oscillator type, internal code execution pattern and temperature, also have an impact on the current consumption. The test conditions for all IDOZE measurements are as follows:

- Oscillator is configured in EC mode and external clock active, OSC1 is driven with external square wave from rail-to-rail (EC clock overshoot/undershoot < 250 mV required)
- CLKO is configured as an I/O input pin in the Configuration Word
- All I/O pins are configured as inputs and pulled to VSS
- MCLR = VDD, WDT and FSCM are disabled
- CPU, SRAM, program memory and data memory are operational
- No peripheral modules are operating; however, every peripheral is being clocked (all PMDx bits are zeroed)
- CPU executing `while(1)` statement
- JTAG disabled

dsPIC33FJ06GS101/X02 and dsPIC33FJ16GSX02/X04

TABLE 24-9: DC CHARACTERISTICS: I/O PIN INPUT SPECIFICATIONS

DC CHARACTERISTICS			Standard Operating Conditions: 3.0V to 3.6V (unless otherwise stated) Operating temperature $-40^{\circ}\text{C} \leq T_A \leq +85^{\circ}\text{C}$ for Industrial $-40^{\circ}\text{C} \leq T_A \leq +125^{\circ}\text{C}$ for Extended				
Param No.	Symbol	Characteristic	Min	Typ ⁽¹⁾	Max	Units	Conditions
	V _{IL}	Input Low Voltage					
DI10		I/O Pins	V _{SS}	—	0.2 V _{DD}	V	
DI15		MCLR	V _{SS}	—	0.2 V _{DD}	V	
DI16		I/O Pins with OSC1	V _{SS}	—	0.2 V _{DD}	V	
DI18		I/O Pins with SDAx, SCLx	V _{SS}	—	0.3 V _{DD}	V	SMBus disabled
DI19		I/O Pins with SDAx, SCLx	V _{SS}	—	0.8	V	SMBus enabled
	V _{IH}	Input High Voltage					
DI20		I/O Pins Not 5V Tolerant ⁽⁴⁾	0.7 V _{DD}	—	V _{DD}	V	
DI21		I/O Pins 5V Tolerant ⁽⁴⁾	0.7 V _{DD}	—	5.5	V	
DI28		SDA1, SCL1	0.7 V _{DD}	—	5.5	V	SMBus disabled
DI29		SDA1, SCL1	2.1	—	5.5	V	SMBus enabled
	IC _{NPU}	CNx Pull-up Current					
DI30			—	250	—	μA	V _{DD} = 3.3V, V _{PIN} = V _{SS}
	I _{IL}	Input Leakage Current^(2,3,4)					
DI50		I/O Pins with: 4x Driver Pins - RA0-RA2, RB0-RB2, RB5-RB10, RB15, RC1, RC2, RC9, RC10	—	—	±2	μA	V _{SS} ≤ V _{PIN} ≤ V _{DD} , Pin at high-impedance
		8x Driver Pins - RC0, RC3-RC8, RC11-RC13	—	—	±4	μA	V _{SS} ≤ V _{PIN} ≤ V _{DD} , Pin at high-impedance
		16x Driver Pins - RA3, RA4, RB3, RB4, RB11-RB14	—	—	±8	μA	V _{SS} ≤ V _{PIN} ≤ V _{DD} , Pin at high-impedance
DI55		MCLR	—	—	±2	μA	V _{SS} ≤ V _{PIN} ≤ V _{DD}
DI56		OSC1	—	—	±2	μA	V _{SS} ≤ V _{PIN} ≤ V _{DD} , XT and HS modes

- Note 1:** Data in “Typ” column is at 3.3V, +25°C unless otherwise stated.
- 2:** The leakage current on the MCLR pin is strongly dependent on the applied voltage level. The specified levels represent normal operating conditions. Higher leakage current may be measured at different input voltages.
- 3:** Negative current is defined as current sourced by the pin.
- 4:** See “[Pin Diagrams](#)” for the list of 5V tolerant I/O pins.
- 5:** V_{IL} source < (V_{SS} – 0.3). Characterized but not tested.
- 6:** Non-5V tolerant pins V_{IH} source > (V_{DD} + 0.3), 5V tolerant pins V_{IH} source > 5.5V. Characterized but not tested.
- 7:** Digital 5V tolerant pins cannot tolerate any “positive” input injection current from input sources > 5.5V.
- 8:** Injection currents > |0| can affect the ADC results by approximately 4-6 counts.
- 9:** Any number and/or combination of I/O pins not excluded under I_{ICL} or I_{ICH} conditions are permitted provided the mathematical “absolute instantaneous” sum of the input injection currents from all pins do not exceed the specified limit. Characterized but not tested.

dsPIC33FJ06GS101/X02 and dsPIC33FJ16GSX02/X04

TABLE 24-9: DC CHARACTERISTICS: I/O PIN INPUT SPECIFICATIONS (CONTINUED)

DC CHARACTERISTICS			Standard Operating Conditions: 3.0V to 3.6V (unless otherwise stated) Operating temperature -40°C ≤ TA ≤ +85°C for Industrial -40°C ≤ TA ≤ +125°C for Extended				
Param No.	Symbol	Characteristic	Min	Typ ⁽¹⁾	Max	Units	Conditions
DI60a	I _{ICL}	Input Low Injection Current	0	—	-5 ^(5,8)	mA	All pins except V _{DD} , V _{SS} , AV _{DD} , AV _{SS} , MCLR, VCAP and RB5
DI60b	I _{ICH}	Input High Injection Current	0	—	+5 ^(6,7,8)	mA	All pins except V _{DD} , V _{SS} , AV _{DD} , AV _{SS} , MCLR, VCAP, RB5 and digital 5V-tolerant designated pins
DI60c	∑ I _{ICT}	Total Input Injection Current (sum of all I/O and control pins)	-20 ⁽⁹⁾	—	+20 ⁽⁹⁾	mA	Absolute instantaneous sum of all ± input injection currents from all I/O pins (I _{ICL} + I _{ICH}) ≤ ∑ I _{ICT}

- Note 1:** Data in “Typ” column is at 3.3V, +25°C unless otherwise stated.
- 2:** The leakage current on the MCLR pin is strongly dependent on the applied voltage level. The specified levels represent normal operating conditions. Higher leakage current may be measured at different input voltages.
- 3:** Negative current is defined as current sourced by the pin.
- 4:** See “[Pin Diagrams](#)” for the list of 5V tolerant I/O pins.
- 5:** V_{IL} source < (V_{SS} – 0.3). Characterized but not tested.
- 6:** Non-5V tolerant pins V_{IH} source > (V_{DD} + 0.3), 5V tolerant pins V_{IH} source > 5.5V. Characterized but not tested.
- 7:** Digital 5V tolerant pins cannot tolerate any “positive” input injection current from input sources > 5.5V.
- 8:** Injection currents > | 0 | can affect the ADC results by approximately 4-6 counts.
- 9:** Any number and/or combination of I/O pins not excluded under I_{ICL} or I_{ICH} conditions are permitted provided the mathematical “absolute instantaneous” sum of the input injection currents from all pins do not exceed the specified limit. Characterized but not tested.

dsPIC33FJ06GS101/X02 and dsPIC33FJ16GSX02/X04

TABLE 24-10: DC CHARACTERISTICS: I/O PIN OUTPUT SPECIFICATIONS

DC CHARACTERISTICS			Standard Operating Conditions: 3.0V to 3.6V (unless otherwise stated) Operating temperature $-40^{\circ}\text{C} \leq T_A \leq +85^{\circ}\text{C}$ for Industrial $-40^{\circ}\text{C} \leq T_A \leq +125^{\circ}\text{C}$ for Extended				
Param.	Symbol	Characteristic	Min.	Typ.	Max.	Units	Conditions
DO10	VOL	Output Low Voltage I/O Pins: 4x Sink Driver Pins – RA0-RA2, RB0-RB2, RB5-RB10, RB15, RC1, RC2, RC9, RC10	—	—	0.4	V	$I_{OL} \leq 6 \text{ mA}$, $V_{DD} = 3.3\text{V}$ See Note 1
		Output Low Voltage I/O Pins: 8x Sink Driver Pins – RC0, RC3-RC8, RC11-RC13	—	—	0.4	V	$I_{OL} \leq 10 \text{ mA}$, $V_{DD} = 3.3\text{V}$ See Note 1
		Output Low Voltage I/O Pins: 16x Sink Driver Pins – RA3, RA4, RB3, RB4, RB11-RB14	—	—	0.4	V	$I_{OL} \leq 18 \text{ mA}$, $V_{DD} = 3.3\text{V}$ See Note 1
DO20	VOH	Output High Voltage I/O Pins: 4x Source Driver Pins – RA0-RA2, RB0-RB2, RB5- RB10, RB15, RC1, RC2, RC9, RC10	2.4	—	—	V	$I_{OH} \geq -6 \text{ mA}$, $V_{DD} = 3.3\text{V}$ See Note 1
		Output High Voltage I/O Pins: 8x Source Driver Pins – RC0, RC3-RC8, RC11-RC13	2.4	—	—	V	$I_{OH} \geq -10 \text{ mA}$, $V_{DD} = 3.3\text{V}$ See Note 1
		Output High Voltage I/O Pins: 16x Source Driver Pins – RA3, RA4, RB3, RB4, RB11-RB14	2.4	—	—	V	$I_{OH} \geq -18 \text{ mA}$, $V_{DD} = 3.3\text{V}$ See Note 1
DO20A	VOH1	Output High Voltage I/O Pins: 4x Source Driver Pins – RA0-RA2, RB0-RB2, RB5-RB10, RB15, RC1, RC2, RC9, RC10	1.5	—	—	V	$I_{OH} \geq -12 \text{ mA}$, $V_{DD} = 3.3\text{V}$ See Note 1
			2.0	—	—		$I_{OH} \geq -11 \text{ mA}$, $V_{DD} = 3.3\text{V}$ See Note 1
			3.0	—	—		$I_{OH} \geq -3 \text{ mA}$, $V_{DD} = 3.3\text{V}$ See Note 1
		Output High Voltage 8x Source Driver Pins – RC0, RC3-RC8, RC11-RC13	1.5	—	—	V	$I_{OH} \geq -16 \text{ mA}$, $V_{DD} = 3.3\text{V}$ See Note 1
			2.0	—	—		$I_{OH} \geq -12 \text{ mA}$, $V_{DD} = 3.3\text{V}$ See Note 1
			3.0	—	—		$I_{OH} \geq -4 \text{ mA}$, $V_{DD} = 3.3\text{V}$ See Note 1
		Output High Voltage I/O Pins: 16x Source Driver Pins – RA3, RA4, RB3, RB4, RB11-RB14	1.5	—	—	V	$I_{OH} \geq -30 \text{ mA}$, $V_{DD} = 3.3\text{V}$ See Note 1
			2.0	—	—		$I_{OH} \geq -25 \text{ mA}$, $V_{DD} = 3.3\text{V}$ See Note 1
			3.0	—	—		$I_{OH} \geq -8 \text{ mA}$, $V_{DD} = 3.3\text{V}$ See Note 1

Note 1: Parameters are characterized, but not tested.

dsPIC33FJ06GS101/X02 and dsPIC33FJ16GSX02/X04

TABLE 24-11: ELECTRICAL CHARACTERISTICS: BOR

DC CHARACTERISTICS			Standard Operating Conditions (see Note 3): 3.0V to 3.6V (unless otherwise stated) Operating temperature -40°C ≤ TA ≤ +85°C for Industrial -40°C ≤ TA ≤ +125°C for Extended				
Param No.	Symbol	Characteristic	Min ⁽¹⁾	Typ	Max	Units	Conditions
BO10	VBOR	BOR Event on VDD Transition High-to-Low BOR Event is Tied to VDD Core Voltage Decrease	2.55	—	2.79	V	See Note 2

Note 1: Parameters are for design guidance only and are not tested in manufacturing.

Note 2: The device will operate as normal until the VDDMIN threshold is reached.

Note 3: Overall functional device operation at VBORMIN < VDD < VDDMIN is tested but not characterized. All device analog modules such as the ADC, etc., will function but with degraded performance below VDDMIN.

dsPIC33FJ06GS101/X02 and dsPIC33FJ16GSX02/X04

TABLE 24-12: DC CHARACTERISTICS: PROGRAM MEMORY

DC CHARACTERISTICS			Standard Operating Conditions: 3.0V to 3.6V (unless otherwise stated) Operating temperature -40°C ≤ TA ≤ +85°C for Industrial -40°C ≤ TA ≤ +125°C for Extended				
Param No.	Symbol	Characteristic	Min	Typ ⁽¹⁾	Max	Units	Conditions
Program Flash Memory							
D130	EP	Cell Endurance	10,000	—	—	E/W	-40°C to +125°C
D131	VPR	VDD for Read	V _{MIN}	—	3.6	V	V _{MIN} = Minimum operating voltage
D132B	VPEW	VDD for Self-Timed Write	V _{MIN}	—	3.6	V	V _{MIN} = Minimum operating voltage
D134	TRETD	Characteristic Retention	20	—	—	Year	Provided no other specifications are violated, -40°C to +125°C
D135	IDDP	Supply Current during Programming	—	10	—	mA	
D136a	TRW	Row Write Time	1.477	—	1.538	ms	TRW = 11064 FRC cycles, TA = +85°C, See Note 2
D136b	TRW	Row Write Time	1.435	—	1.586	ms	TRW = 11064 FRC cycles, TA = +125°C, See Note 2
D137a	TPE	Page Erase Time	22.5	—	23.4	ms	TPE = 168517 FRC cycles, TA = +85°C, See Note 2
D137b	TPE	Page Erase Time	21.9	—	24.2	ms	TPE = 168517 FRC cycles, TA = +125°C, See Note 2
D138a	TWW	Word Write Cycle Time	47.4	—	49.3	μs	TWW = 355 FRC cycles, TA = +85°C, See Note 2
D138b	TWW	Word Write Cycle Time	46	—	50.9	μs	TWW = 355 FRC cycles, TA = +125°C, See Note 2

Note 1: Data in "Typ" column is at 3.3V, +25°C unless otherwise stated.

- 2:** Other conditions: FRC = 7.37 MHz, TUN<5:0> = b'011111 (for Min), TUN<5:0> = b'100000 (for Max). This parameter depends on the FRC accuracy (see [Table 24-20](#)) and the value of the FRC Oscillator Tuning register (see [Register 9-4](#)). For complete details on calculating the Minimum and Maximum time see [Section 5.3 "Programming Operations"](#).

TABLE 24-13: INTERNAL VOLTAGE REGULATOR SPECIFICATIONS

Operating Conditions: -40°C ≤ TA ≤ +85°C for Industrial -40°C ≤ TA ≤ +125°C for Extended							
Param No.	Symbol	Characteristics	Min	Typ	Max	Units	Comments
—	CEFC	External Filter Capacitor Value ⁽¹⁾	4.7	10	—	μF	Capacitor must be low series resistance (< 5 ohms)

Note 1: Typical V_{CAP} voltage = 2.5 volts when V_{DD} ≥ V_{DDMIN}.

dsPIC33FJ06GS101/X02 and dsPIC33FJ16GSX02/X04

24.2 AC Characteristics and Timing Parameters

This section defines dsPIC33FJ06GS101/X02 and dsPIC33FJ16GSX02/X04 AC characteristics and timing parameters.

TABLE 24-14: TEMPERATURE AND VOLTAGE SPECIFICATIONS – AC

AC CHARACTERISTICS	Standard Operating Conditions: 3.0V to 3.6V (unless otherwise stated)
	Operating temperature $-40^{\circ}\text{C} \leq T_A \leq +85^{\circ}\text{C}$ for Industrial $-40^{\circ}\text{C} \leq T_A \leq +125^{\circ}\text{C}$ for Extended Operating voltage V_{DD} range as described in Table 24-1 .

FIGURE 24-1: LOAD CONDITIONS FOR DEVICE TIMING SPECIFICATIONS



TABLE 24-15: CAPACITIVE LOADING REQUIREMENTS ON OUTPUT PINS

Param No.	Symbol	Characteristic	Min	Typ	Max	Units	Conditions
DO50	Cosco	OSC2 Pin	—	—	15	pF	In XT and HS modes when external clock is used to drive OSC1
DO56	Cio	All I/O Pins and OSC2	—	—	50	pF	EC mode
DO58	CB	SCLx, SDAx	—	—	400	pF	In I ² C™ mode

dsPIC33FJ06GS101/X02 and dsPIC33FJ16GSX02/X04

FIGURE 24-2: EXTERNAL CLOCK TIMING



TABLE 24-16: EXTERNAL CLOCK TIMING REQUIREMENTS

AC CHARACTERISTICS			Standard Operating Conditions: 3.0V to 3.6V (unless otherwise stated) Operating temperature -40°C ≤ TA ≤ +85°C for Industrial -40°C ≤ TA ≤ +125°C for Extended				
Param No.	Symb	Characteristic	Min	Typ ⁽¹⁾	Max	Units	Conditions
OS10	FIN	External CLKI Frequency (External clocks allowed only in EC and ECPLL modes)	DC	—	40	MHz	EC
		Oscillator Crystal Frequency	3.5 10	— —	10 40	MHz MHz	XT HS
OS20	TOSC	TOSC = 1/FOSC	12.5	—	DC	ns	
OS25	Tcy	Instruction Cycle Time ⁽²⁾	25	—	DC	ns	
OS30	TosL, TosH	External Clock in (OSC1) High or Low Time	0.375 x TOSC	—	0.625 x TOSC	ns	EC
		External Clock in (OSC1) Rise or Fall Time	—	—	20	ns	EC
OS40	TckR	CLKO Rise Time ⁽³⁾	—	5.2	—	ns	
OS41	TckF	CLKO Fall Time ⁽³⁾	—	5.2	—	ns	
OS42	GM	External Oscillator Transconductance ⁽⁴⁾	14	16	18	mA/V	VDD = 3.3V, TA = +25°C

Note 1: Data in “Typ” column is at 3.3V, +25°C unless otherwise stated.

2: Instruction cycle period (Tcy) equals two times the input oscillator time-base period. All specified values are based on characterization data for that particular oscillator type under standard operating conditions with the device executing code. Exceeding these specified limits may result in an unstable oscillator operation and/or higher than expected current consumption. All devices are tested to operate at “min.” values with an external clock applied to the OSC1/CLKI pin. When an external clock input is used, the “max.” cycle time limit is “DC” (no clock) for all devices.

3: Measurements are taken in EC mode. The CLKO signal is measured on the OSC2 pin.

4: Data for this parameter is Preliminary. This parameter is characterized, but not tested in manufacturing.

dsPIC33FJ06GS101/X02 and dsPIC33FJ16GSX02/X04

TABLE 24-17: PLL CLOCK TIMING SPECIFICATIONS (V_{DD} = 3.0V TO 3.6V)

AC CHARACTERISTICS			Standard Operating Conditions: 3.0V to 3.6V (unless otherwise stated) Operating temperature -40°C ≤ T _A ≤ +85°C for Industrial -40°C ≤ T _A ≤ +125°C for Extended				
Param No.	Symbol	Characteristic	Min	Typ ⁽¹⁾	Max	Units	Conditions
OS50	FPLLI	PLL Voltage Controlled Oscillator (VCO) Input Frequency Range	0.8	—	8	MHz	ECPLL, XTPLL modes
OS51	FSYS	On-Chip VCO System Frequency	100	—	200	MHz	
OS52	TLOCK	PLL Start-up Time (Lock Time)	0.9	1.5	3.1	mS	
OS53	DCLK	CLKO Stability (Jitter) ⁽²⁾	-3	0.5	3	%	Measured over 100 ms period

- Note 1:** Data in “Typ” column is at 3.3V, +25°C unless otherwise stated. Parameters are for design guidance only and are not tested in manufacturing.
- 2:** These parameters are characterized by similarity, but are not tested in manufacturing. This specification is based on clock cycle by clock cycle measurements. To calculate the effective jitter for individual time bases or communication clocks use this formula:

$$\text{Peripheral Clock Jitter} = \frac{DCLK}{\sqrt{\left(\frac{FOSC}{\text{Peripheral Bit Rate Clock}}\right)}}$$

For example: FOSC = 32 MHz, DCLK = 3%, SPI bit rate clock (i.e., SCKx) is 2 MHz.

$$\text{SPI SCK Jitter} = \left[\frac{DCLK}{\sqrt{\left(\frac{32 \text{ MHz}}{2 \text{ MHz}}\right)}} \right] = \left[\frac{3\%}{\sqrt{16}} \right] = \left[\frac{3\%}{4} \right] = 0.75\%$$

TABLE 24-18: AUXILIARY PLL CLOCK TIMING SPECIFICATIONS (V_{DD} = 3.0V TO 3.6V)

AC CHARACTERISTICS			Standard Operating Conditions: 3.0V to 3.6V (unless otherwise stated) Operating temperature -40°C ≤ T _A ≤ +85°C for Industrial -40°C ≤ T _A ≤ +125°C for Extended				
Param No.	Symbol	Characteristic	Min	Typ ⁽¹⁾	Max	Units	Conditions
OS56	FHPOUT	On-Chip 16x PLL CCO Frequency	112	118	120	MHz	
OS57	FHPIN	On-Chip 16x PLL Phase Detector Input Frequency	7.0	7.37	7.5	MHz	
OS58	TSU	Frequency Generator Lock Time	—	—	10	μs	

- Note 1:** Data in “Typ” column is at 3.3V, +25°C unless otherwise stated. Parameters are for design guidance only and are not tested in manufacturing.

dsPIC33FJ06GS101/X02 and dsPIC33FJ16GSX02/X04

TABLE 24-19: AC CHARACTERISTICS: INTERNAL FRC ACCURACY

AC CHARACTERISTICS		Standard Operating Conditions: 3.0V to 3.6V (unless otherwise stated) Operating temperature -40°C ≤ TA ≤ +85°C for industrial -40°C ≤ TA ≤ +125°C for Extended					
Param No.	Characteristic	Min	Typ	Max	Units	Conditions	
Internal FRC Accuracy @ FRC Frequency = 7.37 MHz⁽¹⁾							
F20a	FRC	-2	—	+2	%	-40°C ≤ TA ≤ +85°C	VDD = 3.0-3.6V
F20b	FRC	-5	—	+5	%	-40°C ≤ TA ≤ +125°C	VDD = 3.0-3.6V

Note 1: Frequency calibrated at +25°C and 3.3V. TUNx bits can be used to compensate for temperature drift.

TABLE 24-20: AC CHARACTERISTICS: INTERNAL LPRC ACCURACY

AC CHARACTERISTICS		Standard Operating Conditions: 3.0V to 3.6V (unless otherwise stated) Operating temperature -40°C ≤ TA ≤ +85°C for Industrial -40°C ≤ TA ≤ +125°C for Extended					
Param No.	Characteristic	Min	Typ	Max	Units	Conditions	
LPRC @ 32.768 kHz⁽¹⁾							
F21a	LPRC	-20	±6	+20	%	-40°C ≤ TA ≤ +85°C	VDD = 3.0-3.6V
F21b	LPRC	-70	—	+70	%	-40°C ≤ TA ≤ +125°C	VDD = 3.0-3.6V

Note 1: Change of LPRC frequency as VDD changes.

dsPIC33FJ06GS101/X02 and dsPIC33FJ16GSX02/X04

FIGURE 24-3: I/O TIMING CHARACTERISTICS

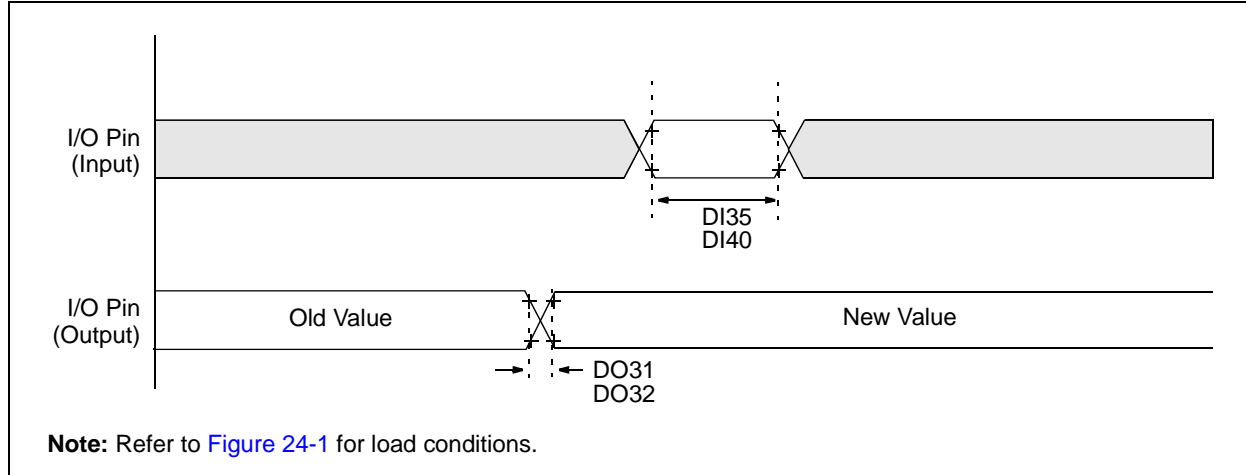

TABLE 24-21: I/O TIMING REQUIREMENTS

AC CHARACTERISTICS		Standard Operating Conditions: 3.0V to 3.6V(unless otherwise stated) Operating temperature $-40^{\circ}\text{C} \leq T_A \leq +85^{\circ}\text{C}$ for Industrial $-40^{\circ}\text{C} \leq T_A \leq +125^{\circ}\text{C}$ for Extended					
Param No.	Symbol	Characteristic	Min	Typ ⁽¹⁾	Max	Units	Conditions
DO31	TioR	Port Output Rise Time:					Refer to Figure 24-1 for test conditions
		4x Source Driver Pins – RA0-RA2, RB0-RB2, RB5-RB10, RB15, RC1, RC2, RC9, RC10	—	10	25	ns	
		8x Source Driver Pins – RC0, RC3-RC8, RC11-RC13	—	8	20	ns	
		16x Source Driver Pins – RA3, RA4, RB3, RB4, RB11-RB14	—	6	15	ns	
DO32	TioF	Port Output Fall Time:					Refer to Figure 24-1 for test conditions
		4x Source Driver Pins – RA0-RA2, RB0-RB2, RB5-RB10, RB15, RC1, RC2, RC9, RC10	—	10	25	ns	
		8x Source Driver Pins – RC0, RC3-RC8, RC11-RC13	—	8	20	ns	
		16x Source Driver Pins – RA3, RA4, RB3, RB4, RB11-RB14	—	6	15	ns	
DI35	TINP	INTx Pin High or Low Time (input)	20	—	—	ns	
DI40	TRBP	CNx High or Low Time (input)	2	—	—	TCY	

Note 1: Data in “Typ” column is at 3.3V, +25°C unless otherwise stated.

dsPIC33FJ06GS101/X02 and dsPIC33FJ16GSX02/X04

FIGURE 24-4: RESET, WATCHDOG TIMER, OSCILLATOR START-UP TIMER AND POWER-UP TIMER TIMING CHARACTERISTICS



dsPIC33FJ06GS101/X02 and dsPIC33FJ16GSX02/X04

TABLE 24-22: RESET, WATCHDOG TIMER, OSCILLATOR START-UP TIMER, POWER-UP TIMER TIMING REQUIREMENTS

AC CHARACTERISTICS			Standard Operating Conditions: 3.0V to 3.6V (unless otherwise stated) Operating temperature -40°C ≤ TA ≤ +85°C for Industrial -40°C ≤ TA ≤ +125°C for Extended				
Param No.	Symbol	Characteristic ⁽¹⁾	Min	Typ ⁽²⁾	Max	Units	Conditions
SY10	TMCL	MCLR Pulse Width (low)	2	—	—	μs	-40°C to +85°C
SY11	TPWRT	Power-up Timer Period	—	2 4 8 16 32 64 128	—	ms	-40°C to +85°C, User programmable
SY12	TPOR	Power-on Reset Delay	3	10	30	μs	-40°C to +85°C
SY13	TIOZ	I/O High-Impedance from MCLR Low or Watchdog Timer Reset	0.68	0.72	1.2	μs	
SY20	TWDT1	Watchdog Timer Time-out Period	—	—	—	ms	See Section 21.4 “Watchdog Timer (WDT)” and LPRC Parameter F21a (Table 24-20)
SY30	TOST	Oscillator Start-up Time	—	1024 TOSC	—	—	TOSC = OSC1 period

Note 1: These parameters are characterized but not tested in manufacturing.

2: Data in “Typ” column is at 3.3V, +25°C unless otherwise stated.

dsPIC33FJ06GS101/X02 and dsPIC33FJ16GSX02/X04

FIGURE 24-5: TIMER1, 2 AND 3 EXTERNAL CLOCK TIMING CHARACTERISTICS



TABLE 24-23: TIMER1 EXTERNAL CLOCK TIMING REQUIREMENTS⁽¹⁾

AC CHARACTERISTICS		Standard Operating Conditions: 3.0V to 3.6V (unless otherwise stated) Operating temperature $-40^{\circ}\text{C} \leq T_A \leq +85^{\circ}\text{C}$ for Industrial $-40^{\circ}\text{C} \leq T_A \leq +125^{\circ}\text{C}$ for Extended						
Param No.	Symbol	Characteristic		Min.	Typ.	Max.	Units	Conditions
TA10	TTXH	T1CK High Time	Synchronous, no prescaler	$T_{CY} + 20$	—	—	ns	Must also meet Parameter TA15, N = Prescale value (1, 8, 64, 256)
			Synchronous, with prescaler	$(T_{CY} + 20)/N$	—	—	ns	
			Asynchronous	20	—	—	ns	
TA11	TTXL	T1CK Low Time	Synchronous, no prescaler	$T_{CY} + 20$	—	—	ns	Must also meet Parameter TA15, N = Prescale value (1, 8, 64, 256)
			Synchronous, with prescaler	$(T_{CY} + 20)/N$	—	—	ns	
			Asynchronous	20	—	—	ns	
TA15	TTXP	T1CK Input Period	Synchronous, no prescaler	$2 T_{CY} + 40$	—	—	ns	N = Prescale value (1, 8, 64, 256)
			Synchronous, with prescaler	Greater of: 40 ns or $(2 T_{CY} + 40)/N$	—	—	—	
			Asynchronous	40	—	—	ns	
OS60	FT1	T1CK Oscillator Input Frequency Range (oscillator enabled by setting bit, TCS (T1CON<1>))		DC	—	50	kHz	
TA20	TCKEXTMRL	Delay from External T1CK Clock Edge to Timer Increment		$0.75 T_{CY} + 40$	—	$1.75 T_{CY} + 40$	—	

Note 1: Timer1 is a Type A timer.

dsPIC33FJ06GS101/X02 and dsPIC33FJ16GSX02/X04

TABLE 24-24: TIMER2 EXTERNAL CLOCK TIMING REQUIREMENTS

AC CHARACTERISTICS				Standard Operating Conditions: 3.0V to 3.6V (unless otherwise stated) Operating temperature $-40^{\circ}\text{C} \leq T_A \leq +85^{\circ}\text{C}$ for Industrial $-40^{\circ}\text{C} \leq T_A \leq +125^{\circ}\text{C}$ for Extended				
Param No.	Symbol	Characteristic		Min.	Typ.	Max.	Units	Conditions
TB10	TtXH	T2CK High Time	Synchronous	Greater of: 20 ns or (Tcy + 20)/N	—	—	ns	Must also meet Parameter TB15, N = Prescale value (1, 8, 64, 256)
TB11	TtXL	T2CK Low Time	Synchronous	Greater of: 20 ns or (Tcy + 20)/N	—	—	ns	Must also meet Parameter TB15, N = Prescale value (1, 8, 64, 256)
TB15	TtXP	T2CK Input Period	Synchronous	Greater of: 40 ns or (2 Tcy + 40)/N	—	—	ns	N = Prescale value (1, 8, 64, 256)
TB20	TCKEXTMRL	Delay from External T2CK Clock Edge to Timer Increment		0.75 Tcy + 40	—	1.75 Tcy + 40	ns	

TABLE 24-25: TIMER3 EXTERNAL CLOCK TIMING REQUIREMENTS

AC CHARACTERISTICS				Standard Operating Conditions: 3.0V to 3.6V (unless otherwise stated) Operating temperature $-40^{\circ}\text{C} \leq T_A \leq +85^{\circ}\text{C}$ for Industrial $-40^{\circ}\text{C} \leq T_A \leq +125^{\circ}\text{C}$ for Extended				
Param No.	Symbol	Characteristic		Min	Typ	Max	Units	Conditions
TC10	TtXH	T3CK High Time	Synchronous	Tcy + 20	—	—	ns	Must also meet Parameter TC15
TC11	TtXL	T3CK Low Time	Synchronous	Tcy + 20	—	—	ns	Must also meet Parameter TC15
TC15	TtXP	T3CK Input Period	Synchronous, with prescaler	2 Tcy + 40	—	—	ns	
TC20	TCKEXTMRL	Delay from External T3CK Clock Edge to Timer Increment		0.75 Tcy + 40	—	1.75 Tcy + 40	—	

dsPIC33FJ06GS101/X02 and dsPIC33FJ16GSX02/X04

FIGURE 24-6: INPUT CAPTURE x (ICx) TIMING CHARACTERISTICS



TABLE 24-26: INPUT CAPTURE x TIMING REQUIREMENTS

AC CHARACTERISTICS		Standard Operating Conditions: 3.0V to 3.6V (unless otherwise stated) Operating temperature -40°C ≤ TA ≤ +85°C for Industrial -40°C ≤ TA ≤ +125°C for Extended					
Param No.	Symbol	Characteristic ⁽¹⁾		Min	Max	Units	Conditions
IC10	TccL	ICx Input Low Time	No prescaler	0.5 Tcy + 20	—	ns	
			With prescaler	10	—	ns	
IC11	TccH	ICx Input High Time	No prescaler	0.5 Tcy + 20	—	ns	
			With prescaler	10	—	ns	
IC15	TccP	ICx Input Period		(Tcy + 40)/N	—	ns	N = Prescale value (1, 4, 16)

Note 1: These parameters are characterized but not tested in manufacturing.

FIGURE 24-7: OUTPUT COMPARE x MODULE (OCx) TIMING CHARACTERISTICS



TABLE 24-27: OUTPUT COMPARE x MODULE TIMING REQUIREMENTS

AC CHARACTERISTICS		Standard Operating Conditions: 3.0V to 3.6V (unless otherwise stated) Operating temperature -40°C ≤ TA ≤ +85°C for Industrial -40°C ≤ TA ≤ +125°C for Extended					
Param No.	Symbol	Characteristic ⁽¹⁾	Min	Typ	Max	Units	Conditions
OC10	TccF	OCx Output Fall Time	—	—	—	ns	See Parameter DO32
OC11	TccR	OCx Output Rise Time	—	—	—	ns	See Parameter DO31

Note 1: These parameters are characterized but not tested in manufacturing.

dsPIC33FJ06GS101/X02 and dsPIC33FJ16GSX02/X04

FIGURE 24-8: OCx/PWMx MODULE TIMING CHARACTERISTICS



TABLE 24-28: SIMPLE OCx/PWMx MODE TIMING REQUIREMENTS

AC CHARACTERISTICS			Standard Operating Conditions: 3.0V to 3.6V (unless otherwise stated) Operating temperature $-40^{\circ}\text{C} \leq T_A \leq +85^{\circ}\text{C}$ for Industrial $-40^{\circ}\text{C} \leq T_A \leq +125^{\circ}\text{C}$ for Extended				
Param No.	Symbol	Characteristic ⁽¹⁾	Min	Typ	Max	Units	Conditions
OC15	TFD	Fault Input to PWMx I/O Change	—	—	$T_{CY} + 20$	ns	
OC20	TFLT	Fault Input Pulse Width	$T_{CY} + 20$	—	—	ns	

Note 1: These parameters are characterized but not tested in manufacturing.

dsPIC33FJ06GS101/X02 and dsPIC33FJ16GSX02/X04

FIGURE 24-9: HIGH-SPEED PWMx MODULE FAULT TIMING CHARACTERISTICS



FIGURE 24-10: HIGH-SPEED PWMx MODULE TIMING CHARACTERISTICS



TABLE 24-29: HIGH-SPEED PWMx MODULE TIMING REQUIREMENTS

AC CHARACTERISTICS			Standard Operating Conditions: 3.0V to 3.6V (unless otherwise stated) Operating temperature $-40^{\circ}\text{C} \leq T_A \leq +85^{\circ}\text{C}$ for Industrial $-40^{\circ}\text{C} \leq T_A \leq +125^{\circ}\text{C}$ for Extended				
Param No.	Symbol	Characteristic ⁽¹⁾	Min	Typ	Max	Units	Conditions
MP10	T _{FPWM}	PWMx Output Fall Time	—	2.5	—	ns	
MP11	T _{RPWM}	PWMx Output Rise Time	—	2.5	—	ns	
MP20	T _{FD}	Fault Input \downarrow to PWM I/O Change	—	—	15	ns	
MP30	T _{FH}	Minimum PWMx Fault Pulse Width	8	—	—	ns	DTC<1:0> = 10
MP31	T _{PDLY}	Tap Delay	1.04	—	—	ns	ACLK = 120 MHz
MP32	ACLK	PWMx Input Clock	—	—	120	MHz	See Note 2

Note 1: These parameters are characterized but not tested in manufacturing.

Note 2: This parameter is a maximum allowed input clock for the PWMx module.

dsPIC33FJ06GS101/X02 and dsPIC33FJ16GSX02/X04

TABLE 24-30: SPIx MAXIMUM DATA/CLOCK RATE SUMMARY

AC CHARACTERISTICS			Standard Operating Conditions: 3.0V to 3.6V (unless otherwise stated) Operating temperature -40°C ≤ TA ≤ +85°C for Industrial -40°C ≤ TA ≤ +125°C for Extended			
Maximum Data Rate	Master Transmit Only (Half-Duplex)	Master Transmit/Receive (Full-Duplex)	Slave Transmit/Receive (Full-Duplex)	CKE	CKP	SMP
15 MHz	Table 24-31	—	—	0,1	0,1	0,1
9 MHz	—	Table 24-32	—	1	0,1	1
9 MHz	—	Table 24-33	—	0	0,1	1
15 MHz	—	—	Table 24-34	1	0	0
11 MHz	—	—	Table 24-35	1	1	0
15 MHz	—	—	Table 24-36	0	1	0
11 MHz	—	—	Table 24-37	0	0	0

FIGURE 24-11: SPIx MASTER MODE (HALF-DUPLEX, TRANSMIT ONLY, CKE = 0) TIMING CHARACTERISTICS



FIGURE 24-12: SPIx MASTER MODE (HALF-DUPLEX, TRANSMIT ONLY, CKE = 1) TIMING CHARACTERISTICS



dsPIC33FJ06GS101/X02 and dsPIC33FJ16GSX02/X04

TABLE 24-31: SPIx MASTER MODE (HALF-DUPLEX, TRANSMIT ONLY) TIMING REQUIREMENTS

AC CHARACTERISTICS			Standard Operating Conditions: 3.0V to 3.6V (unless otherwise stated) Operating temperature -40°C ≤ TA ≤ +85°C for Industrial -40°C ≤ TA ≤ +125°C for Extended				
Param No.	Symbol	Characteristic ⁽¹⁾	Min	Typ ⁽²⁾	Max	Units	Conditions
SP10	TscP	Maximum SCKx Frequency	—	—	15	MHz	See Note 3
SP20	TscF	SCKx Output Fall Time	—	—	—	ns	See Parameter DO32 and Note 4
SP21	TscR	SCKx Output Rise Time	—	—	—	ns	See Parameter DO31 and Note 4
SP30	TdoF	SDOx Data Output Fall Time	—	—	—	ns	See Parameter DO32 and Note 4
SP31	TdoR	SDOx Data Output Rise Time	—	—	—	ns	See Parameter DO31 and Note 4
SP35	Tsch2doV, TscL2doV	SDOx Data Output Valid after SCKx Edge	—	6	20	ns	
SP36	TdiV2sch, TdiV2scL	SDOx Data Output Setup to First SCKx Edge	30	—	—	ns	

- Note 1:** These parameters are characterized, but are not tested in manufacturing.
- Note 2:** Data in “Typ” column is at 3.3V, +25°C unless otherwise stated.
- Note 3:** The minimum clock period for SCKx is 66.7 ns. Therefore, the clock generated in Master mode must not violate this specification.
- Note 4:** Assumes 50 pF load on all SPIx pins.

dsPIC33FJ06GS101/X02 and dsPIC33FJ16GSX02/X04

FIGURE 24-13: SPIx MASTER MODE (FULL-DUPLEX, CKE = 1, CKP = x, SMP = 1) TIMING CHARACTERISTICS



TABLE 24-32: SPIx MASTER MODE (FULL-DUPLEX, CKE = 1, CKP = x, SMP = 1) TIMING REQUIREMENTS

AC CHARACTERISTICS			Standard Operating Conditions: 3.0V to 3.6V (unless otherwise stated) Operating temperature -40°C ≤ TA ≤ +85°C for Industrial -40°C ≤ TA ≤ +125°C for Extended				
Param No.	Symbol	Characteristic ⁽¹⁾	Min	Typ ⁽²⁾	Max	Units	Conditions
SP10	TscP	Maximum SCKx Frequency	—	—	9	MHz	See Note 3
SP20	TscF	SCKx Output Fall Time	—	—	—	ns	See Parameter DO32 and Note 4
SP21	TscR	SCKx Output Rise Time	—	—	—	ns	See Parameter DO31 and Note 4
SP30	TdoF	SDOx Data Output Fall Time	—	—	—	ns	See Parameter DO32 and Note 4
SP31	TdoR	SDOx Data Output Rise Time	—	—	—	ns	See Parameter DO31 and Note 4
SP35	Tsch2doV, TscL2doV	SDOx Data Output Valid after SCKx Edge	—	6	20	ns	
SP36	TdoV2sc, TdoV2scL	SDOx Data Output Setup to First SCKx Edge	30	—	—	ns	
SP40	TdiV2sch, TdiV2scL	Setup Time of SDIx Data Input to SCKx Edge	30	—	—	ns	
SP41	Tsch2diL, TscL2diL	Hold Time of SDIx Data Input to SCKx Edge	30	—	—	ns	

Note 1: These parameters are characterized, but are not tested in manufacturing.

Note 2: Data in “Typ” column is at 3.3V, +25°C unless otherwise stated.

Note 3: The minimum clock period for SCKx is 111 ns. The clock generated in Master mode must not violate this specification.

Note 4: Assumes 50 pF load on all SPIx pins.

dsPIC33FJ06GS101/X02 and dsPIC33FJ16GSX02/X04

FIGURE 24-14: SPIx MASTER MODE (FULL-DUPLEX, CKE = 0, CKP = x, SMP = 1) TIMING CHARACTERISTICS



TABLE 24-33: SPIx MASTER MODE (FULL-DUPLEX, CKE = 0, CKP = x, SMP = 1) TIMING REQUIREMENTS

AC CHARACTERISTICS			Standard Operating Conditions: 3.0V to 3.6V (unless otherwise stated) Operating temperature $-40^{\circ}\text{C} \leq T_A \leq +85^{\circ}\text{C}$ for Industrial $-40^{\circ}\text{C} \leq T_A \leq +125^{\circ}\text{C}$ for Extended				
Param No.	Symbol	Characteristic ⁽¹⁾	Min	Typ ⁽²⁾	Max	Units	Conditions
SP10	TscP	Maximum SCKx Frequency	—	—	9	MHz	-40°C to $+125^{\circ}\text{C}$ and see Note 3
SP20	TscF	SCKx Output Fall Time	—	—	—	ns	See Parameter DO32 and Note 4
SP21	TscR	SCKx Output Rise Time	—	—	—	ns	See Parameter DO31 and Note 4
SP30	TdoF	SDOx Data Output Fall Time	—	—	—	ns	See Parameter DO32 and Note 4
SP31	TdoR	SDOx Data Output Rise Time	—	—	—	ns	See Parameter DO31 and Note 4
SP35	Tsch2doV, TscL2doV	SDOx Data Output Valid after SCKx Edge	—	6	20	ns	
SP36	TdoV2sch, TdoV2scL	SDOx Data Output Setup to First SCKx Edge	30	—	—	ns	
SP40	TdiV2sch, TdiV2scL	Setup Time of SDIx Data Input to SCKx Edge	30	—	—	ns	
SP41	Tsch2diL, TscL2diL	Hold Time of SDIx Data Input to SCKx Edge	30	—	—	ns	

Note 1: These parameters are characterized, but are not tested in manufacturing.

Note 2: Data in "Typ" column is at 3.3V, $+25^{\circ}\text{C}$ unless otherwise stated.

Note 3: The minimum clock period for SCKx is 111 ns. The clock generated in Master mode must not violate this specification.

Note 4: Assumes 50 pF load on all SPIx pins.

dsPIC33FJ06GS101/X02 and dsPIC33FJ16GSX02/X04

FIGURE 24-15: SPIx SLAVE MODE (FULL-DUPLEX, CKE = 1, CKP = 0, SMP = 0) TIMING CHARACTERISTICS



dsPIC33FJ06GS101/X02 and dsPIC33FJ16GSX02/X04

TABLE 24-34: SPIx SLAVE MODE (FULL-DUPLEX, CKE = 1, CKP = 0, SMP = 0) TIMING REQUIREMENTS

AC CHARACTERISTICS			Standard Operating Conditions: 3.0V to 3.6V (unless otherwise stated) Operating temperature -40°C ≤ TA ≤ +85°C for Industrial -40°C ≤ TA ≤ +125°C for Extended				
Param No.	Symbol	Characteristic ⁽¹⁾	Min	Typ ⁽²⁾	Max	Units	Conditions
SP70	TscP	Maximum SCKx Input Frequency	—	—	15	MHz	See Note 3
SP72	TscF	SCKx Input Fall Time	—	—	—	ns	See Parameter DO32 and Note 4
SP73	TscR	SCKx Input Rise Time	—	—	—	ns	See Parameter DO31 and Note 4
SP30	TdoF	SDOx Data Output Fall Time	—	—	—	ns	See Parameter DO32 and Note 4
SP31	TdoR	SDOx Data Output Rise Time	—	—	—	ns	See Parameter DO31 and Note 4
SP35	Tsch2doV, TscL2doV	SDOx Data Output Valid after SCKx Edge	—	6	20	ns	
SP36	TdoV2scH, TdoV2scL	SDOx Data Output Setup to First SCKx Edge	30	—	—	ns	
SP40	TdiV2scH, TdiV2scL	Setup Time of SDIx Data Input to SCKx Edge	30	—	—	ns	
SP41	Tsch2diL, TscL2diL	Hold Time of SDIx Data Input to SCKx Edge	30	—	—	ns	
SP50	TssL2scH, TssL2scL	$\overline{SSx} \downarrow$ to SCKx \uparrow or SCKx Input	120	—	—	ns	
SP51	TssH2doZ	$\overline{SSx} \uparrow$ to SDOx Output High-Impedance ⁽⁴⁾	10	—	50	ns	
SP52	Tsch2ssH TscL2ssH	\overline{SSx} after SCKx Edge	1.5 Tcy + 40	—	—	ns	See Note 4
SP60	TssL2doV	SDOx Data Output Valid after \overline{SSx} Edge	—	—	50	ns	

Note 1: These parameters are characterized, but are not tested in manufacturing.

2: Data in “Typ” column is at 3.3V, +25°C unless otherwise stated.

3: The minimum clock period for SCKx is 66.7 ns. Therefore, the SCKx clock generated by the Master must not violate this specification.

4: Assumes 50 pF load on all SPIx pins.

dsPIC33FJ06GS101/X02 and dsPIC33FJ16GSX02/X04

FIGURE 24-16: SPIx SLAVE MODE (FULL-DUPLEX, CKE = 1, CKP = 1, SMP = 0) TIMING CHARACTERISTICS



dsPIC33FJ06GS101/X02 and dsPIC33FJ16GSX02/X04

TABLE 24-35: SPIx SLAVE MODE (FULL-DUPLEX, CKE = 1, CKP = 1, SMP = 0) TIMING REQUIREMENTS

AC CHARACTERISTICS			Standard Operating Conditions: 3.0V to 3.6V (unless otherwise stated) Operating temperature -40°C ≤ TA ≤ +85°C for Industrial -40°C ≤ TA ≤ +125°C for Extended				
Param No.	Symbol	Characteristic ⁽¹⁾	Min	Typ ⁽²⁾	Max	Units	Conditions
SP70	TscP	Maximum SCKx Input Frequency	—	—	11	MHz	See Note 3
SP72	TscF	SCKx Input Fall Time	—	—	—	ns	See Parameter DO32 and Note 4
SP73	TscR	SCKx Input Rise Time	—	—	—	ns	See Parameter DO31 and Note 4
SP30	TdoF	SDOx Data Output Fall Time	—	—	—	ns	See Parameter DO32 and Note 4
SP31	TdoR	SDOx Data Output Rise Time	—	—	—	ns	See Parameter DO31 and Note 4
SP35	Tsch2doV, TscL2doV	SDOx Data Output Valid after SCKx Edge	—	6	20	ns	
SP36	TdoV2scH, TdoV2scL	SDOx Data Output Setup to First SCKx Edge	30	—	—	ns	
SP40	TdiV2scH, TdiV2scL	Setup Time of SDIx Data Input to SCKx Edge	30	—	—	ns	
SP41	Tsch2diL, TscL2diL	Hold Time of SDIx Data Input to SCKx Edge	30	—	—	ns	
SP50	TssL2scH, TssL2scL	$\overline{SSx} \downarrow$ to SCKx \uparrow or SCKx Input	120	—	—	ns	
SP51	TssH2doZ	$\overline{SSx} \uparrow$ to SDOx Output High-Impedance ⁽⁴⁾	10	—	50	ns	
SP52	Tsch2ssH TscL2ssH	\overline{SSx} after SCKx Edge	1.5 T _{CY} + 40	—	—	ns	See Note 4
SP60	TssL2doV	SDOx Data Output Valid after \overline{SSx} Edge	—	—	50	ns	

Note 1: These parameters are characterized, but are not tested in manufacturing.

2: Data in “Typ” column is at 3.3V, +25°C unless otherwise stated.

3: The minimum clock period for SCKx is 91 ns. Therefore, the SCKx clock generated by the Master must not violate this specification.

4: Assumes 50 pF load on all SPIx pins.

dsPIC33FJ06GS101/X02 and dsPIC33FJ16GSX02/X04

FIGURE 24-17: SPIx SLAVE MODE (FULL-DUPLEX CKE = 0, CKP = 1, SMP = 0) TIMING CHARACTERISTICS

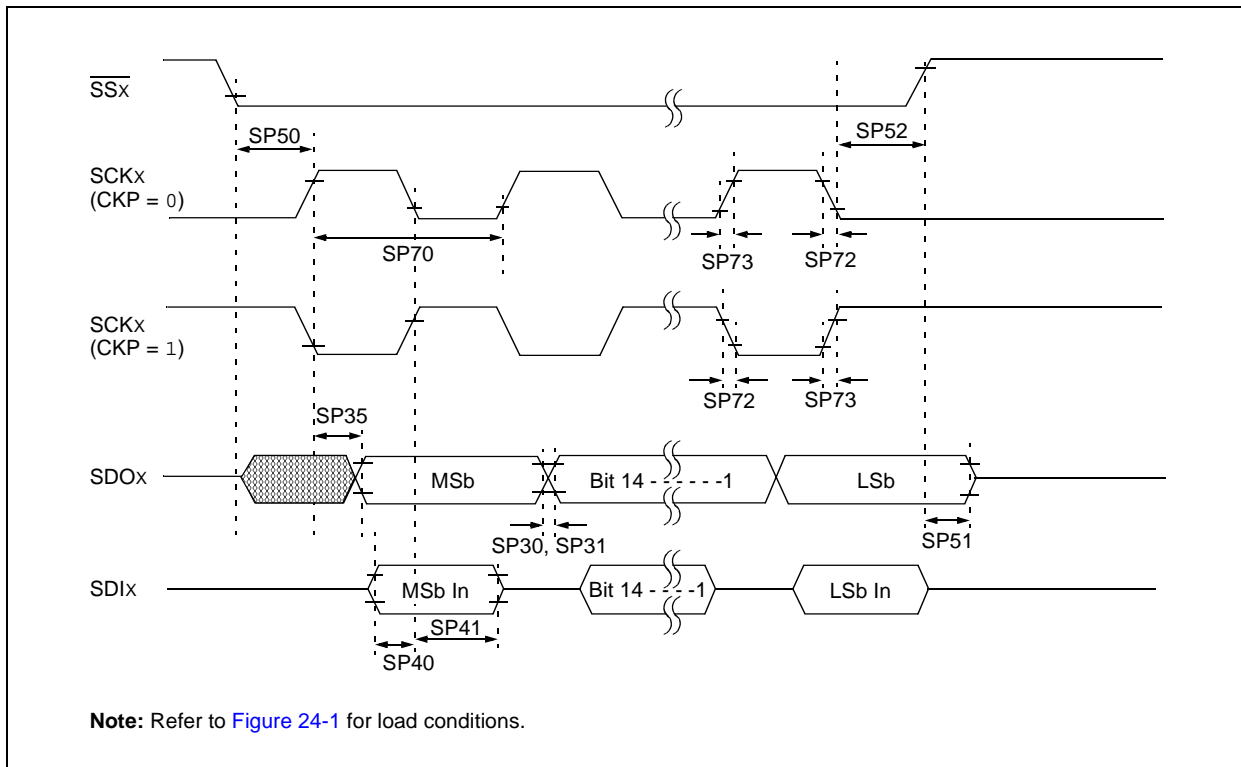

dsPIC33FJ06GS101/X02 and dsPIC33FJ16GSX02/X04

TABLE 24-36: SPIx SLAVE MODE (FULL-DUPLEX, CKE = 0, CKP = 1, SMP = 0) TIMING REQUIREMENTS

AC CHARACTERISTICS			Standard Operating Conditions: 3.0V to 3.6V (unless otherwise stated) Operating temperature -40°C ≤ TA ≤ +85°C for Industrial -40°C ≤ TA ≤ +125°C for Extended				
Param No.	Symbol	Characteristic ⁽¹⁾	Min	Typ ⁽²⁾	Max	Units	Conditions
SP70	TscP	Maximum SCKx Input Frequency	—	—	15	MHz	See Note 3
SP72	TscF	SCKx Input Fall Time	—	—	—	ns	See Parameter DO32 and Note 4
SP73	TscR	SCKx Input Rise Time	—	—	—	ns	See Parameter DO31 and Note 4
SP30	TdoF	SDOx Data Output Fall Time	—	—	—	ns	See Parameter DO32 and Note 4
SP31	TdoR	SDOx Data Output Rise Time	—	—	—	ns	See Parameter DO31 and Note 4
SP35	Tsch2doV, TscL2doV	SDOx Data Output Valid after SCKx Edge	—	6	20	ns	
SP36	TdoV2scH, TdoV2scL	SDOx Data Output Setup to First SCKx Edge	30	—	—	ns	
SP40	TdiV2scH, TdiV2scL	Setup Time of SDIx Data Input to SCKx Edge	30	—	—	ns	
SP41	Tsch2diL, TscL2diL	Hold Time of SDIx Data Input to SCKx Edge	30	—	—	ns	
SP50	TssL2scH, TssL2scL	$\overline{SSx} \downarrow$ to SCKx \uparrow or SCKx Input	120	—	—	ns	
SP51	TssH2doZ	$\overline{SSx} \uparrow$ to SDOx Output High-Impedance	10	—	50	ns	See Note 4
SP52	Tsch2ssH, TscL2ssH	\overline{SSx} after SCKx Edge	1.5 T _{CY} + 40	—	—	ns	See Note 4

Note 1: These parameters are characterized, but are not tested in manufacturing.

2: Data in “Typ” column is at 3.3V, +25°C unless otherwise stated.

3: The minimum clock period for SCKx is 66.7 ns. Therefore, the SCKx clock generated by the Master must not violate this specification.

4: Assumes 50 pF load on all SPIx pins.

dsPIC33FJ06GS101/X02 and dsPIC33FJ16GSX02/X04

FIGURE 24-18: SPIx SLAVE MODE (FULL-DUPLEX, CKE = 0, CKP = 0, SMP = 0) TIMING CHARACTERISTICS



dsPIC33FJ06GS101/X02 and dsPIC33FJ16GSX02/X04

TABLE 24-37: SPIx SLAVE MODE (FULL-DUPLEX, CKE = 0, CKP = 0, SMP = 0) TIMING REQUIREMENTS

AC CHARACTERISTICS			Standard Operating Conditions: 3.0V to 3.6V (unless otherwise stated) Operating temperature -40°C ≤ TA ≤ +85°C for Industrial -40°C ≤ TA ≤ +125°C for Extended				
Param No.	Symbol	Characteristic ⁽¹⁾	Min	Typ ⁽²⁾	Max	Units	Conditions
SP70	TscP	Maximum SCKx Input Frequency	—	—	11	MHz	See Note 3
SP72	TscF	SCKx Input Fall Time	—	—	—	ns	See Parameter DO32 and Note 4
SP73	TscR	SCKx Input Rise Time	—	—	—	ns	See Parameter DO31 and Note 4
SP30	TdoF	SDOx Data Output Fall Time	—	—	—	ns	See Parameter DO32 and Note 4
SP31	TdoR	SDOx Data Output Rise Time	—	—	—	ns	See Parameter DO31 and Note 4
SP35	Tsch2doV, TscL2doV	SDOx Data Output Valid after SCKx Edge	—	6	20	ns	
SP36	TdoV2scH, TdoV2scL	SDOx Data Output Setup to First SCKx Edge	30	—	—	ns	
SP40	TdiV2scH, TdiV2scL	Setup Time of SDIx Data Input to SCKx Edge	30	—	—	ns	
SP41	Tsch2diL, TscL2diL	Hold Time of SDIx Data Input to SCKx Edge	30	—	—	ns	
SP50	TssL2scH, TssL2scL	$\overline{SSx} \downarrow$ to SCKx \uparrow or SCKx Input	120	—	—	ns	
SP51	TssH2doZ	$\overline{SSx} \uparrow$ to SDOx Output High-Impedance	10	—	50	ns	See Note 4
SP52	Tsch2ssH TscL2ssH	\overline{SSx} after SCKx Edge	1.5 T _{CY} + 40	—	—	ns	See Note 4

- Note 1:** These parameters are characterized, but are not tested in manufacturing.
- Note 2:** Data in “Typ” column is at 3.3V, +25°C unless otherwise stated.
- Note 3:** The minimum clock period for SCKx is 91 ns. Therefore, the SCKx clock generated by the Master must not violate this specification.
- Note 4:** Assumes 50 pF load on all SPIx pins.

dsPIC33FJ06GS101/X02 and dsPIC33FJ16GSX02/X04

FIGURE 24-19: I2Cx BUS START/STOP BITS TIMING CHARACTERISTICS (MASTER MODE)



FIGURE 24-20: I2Cx BUS DATA TIMING CHARACTERISTICS (MASTER MODE)



dsPIC33FJ06GS101/X02 and dsPIC33FJ16GSX02/X04

TABLE 24-38: I2Cx BUS DATA TIMING REQUIREMENTS (MASTER MODE)

AC CHARACTERISTICS				Standard Operating Conditions: 3.0V to 3.6V (unless otherwise stated) Operating temperature $-40^{\circ}\text{C} \leq T_A \leq +85^{\circ}\text{C}$ for Industrial $-40^{\circ}\text{C} \leq T_A \leq +125^{\circ}\text{C}$ for Extended			
Param No.	Symbol	Characteristic		Min ⁽¹⁾	Max	Units	Conditions
IM10	TLO:SCL	Clock Low Time	100 kHz mode	$T_{CY}/2$ (BRG + 1)	—	μs	
			400 kHz mode	$T_{CY}/2$ (BRG + 1)	—	μs	
			1 MHz mode ⁽²⁾	$T_{CY}/2$ (BRG + 1)	—	μs	
IM11	THI:SCL	Clock High Time	100 kHz mode	$T_{CY}/2$ (BRG + 1)	—	μs	
			400 kHz mode	$T_{CY}/2$ (BRG + 1)	—	μs	
			1 MHz mode ⁽²⁾	$T_{CY}/2$ (BRG + 1)	—	μs	
IM20	TF:SCL	SDAx and SCLx Fall Time	100 kHz mode	—	300	ns	Cb is specified to be from 10 pF to 400 pF
			400 kHz mode	$20 + 0.1 C_b$	300	ns	
			1 MHz mode ⁽²⁾	—	100	ns	
IM21	TR:SCL	SDAx and SCLx Rise Time	100 kHz mode	—	1000	ns	Cb is specified to be from 10 pF to 400 pF
			400 kHz mode	$20 + 0.1 C_b$	300	ns	
			1 MHz mode ⁽²⁾	—	300	ns	
IM25	TSU:DAT	Data Input Setup Time	100 kHz mode	250	—	ns	
			400 kHz mode	100	—	ns	
			1 MHz mode ⁽²⁾	40	—	ns	
IM26	THD:DAT	Data Input Hold Time	100 kHz mode	0	—	μs	
			400 kHz mode	0	0.9	μs	
			1 MHz mode ⁽²⁾	0.2	—	μs	
IM30	TSU:STA	Start Condition Setup Time	100 kHz mode	$T_{CY}/2$ (BRG + 1)	—	μs	Only relevant for Repeated Start condition
			400 kHz mode	$T_{CY}/2$ (BRG + 1)	—	μs	
			1 MHz mode ⁽²⁾	$T_{CY}/2$ (BRG + 1)	—	μs	
IM31	THD:STA	Start Condition Hold Time	100 kHz mode	$T_{CY}/2$ (BRG + 1)	—	μs	After this period the first clock pulse is generated
			400 kHz mode	$T_{CY}/2$ (BRG + 1)	—	μs	
			1 MHz mode ⁽²⁾	$T_{CY}/2$ (BRG + 1)	—	μs	
IM33	TSU:STO	Stop Condition Setup Time	100 kHz mode	$T_{CY}/2$ (BRG + 1)	—	μs	
			400 kHz mode	$T_{CY}/2$ (BRG + 1)	—	μs	
			1 MHz mode ⁽²⁾	$T_{CY}/2$ (BRG + 1)	—	μs	
IM34	THD:STO	Stop Condition Hold Time	100 kHz mode	$T_{CY}/2$ (BRG + 1)	—	ns	
			400 kHz mode	$T_{CY}/2$ (BRG + 1)	—	ns	
			1 MHz mode ⁽²⁾	$T_{CY}/2$ (BRG + 1)	—	ns	
IM40	TAA:SCL	Output Valid From Clock	100 kHz mode	—	3500	ns	
			400 kHz mode	—	1000	ns	
			1 MHz mode ⁽²⁾	—	400	ns	
IM45	TBF:SDA	Bus Free Time	100 kHz mode	4.7	—	μs	Time the bus must be free before a new transmission can start
			400 kHz mode	1.3	—	μs	
			1 MHz mode ⁽²⁾	0.5	—	μs	
IM50	CB	Bus Capacitive Loading		—	400	pF	
IM51	TPGD	Pulse Gobbler Delay		65	390	ns	See Note 3

Note 1: BRG is the value of the I²C™ Baud Rate Generator. Refer to “Inter-Integrated Circuit (I²C™)” (DS70000195) in the “dsPIC33/PIC24 Family Reference Manual”.

2: Maximum pin capacitance = 10 pF for all I2Cx pins (for 1 MHz mode only).

3: Typical value for this parameter is 130 ns.

dsPIC33FJ06GS101/X02 and dsPIC33FJ16GSX02/X04

FIGURE 24-21: I2Cx BUS START/STOP BITS TIMING CHARACTERISTICS (SLAVE MODE)



FIGURE 24-22: I2Cx BUS DATA TIMING CHARACTERISTICS (SLAVE MODE)



dsPIC33FJ06GS101/X02 and dsPIC33FJ16GSX02/X04

TABLE 24-39: I2Cx BUS DATA TIMING REQUIREMENTS (SLAVE MODE)

AC CHARACTERISTICS				Standard Operating Conditions: 3.0V to 3.6V (unless otherwise stated) Operating temperature -40°C ≤ TA ≤ +85°C for Industrial -40°C ≤ TA ≤ +125°C for Extended			
Param.	Symbol	Characteristic		Min	Max	Units	Conditions
IS10	TLO:SCL	Clock Low Time	100 kHz mode	4.7	—	μs	Device must operate at a minimum of 1.5 MHz
			400 kHz mode	1.3	—	μs	Device must operate at a minimum of 10 MHz
			1 MHz mode ⁽¹⁾	0.5	—	μs	
IS11	THI:SCL	Clock High Time	100 kHz mode	4.0	—	μs	Device must operate at a minimum of 1.5 MHz
			400 kHz mode	0.6	—	μs	Device must operate at a minimum of 10 MHz
			1 MHz mode ⁽¹⁾	0.5	—	μs	
IS20	TF:SCL	SDAx and SCLx Fall Time	100 kHz mode	—	300	ns	Cb is specified to be from 10 pF to 400 pF
			400 kHz mode	20 + 0.1 Cb	300	ns	
			1 MHz mode ⁽¹⁾	—	100	ns	
IS21	TR:SCL	SDAx and SCLx Rise Time	100 kHz mode	—	1000	ns	Cb is specified to be from 10 pF to 400 pF
			400 kHz mode	20 + 0.1 Cb	300	ns	
			1 MHz mode ⁽¹⁾	—	300	ns	
IS25	TSU:DAT	Data Input Setup Time	100 kHz mode	250	—	ns	
			400 kHz mode	100	—	ns	
			1 MHz mode ⁽¹⁾	100	—	ns	
IS26	THD:DAT	Data Input Hold Time	100 kHz mode	0	—	μs	
			400 kHz mode	0	0.9	μs	
			1 MHz mode ⁽¹⁾	0	0.3	μs	
IS30	TSU:STA	Start Condition Setup Time	100 kHz mode	4.7	—	μs	Only relevant for Repeated Start condition
			400 kHz mode	0.6	—	μs	
			1 MHz mode ⁽¹⁾	0.25	—	μs	
IS31	THD:STA	Start Condition Hold Time	100 kHz mode	4.0	—	μs	After this period, the first clock pulse is generated
			400 kHz mode	0.6	—	μs	
			1 MHz mode ⁽¹⁾	0.25	—	μs	
IS33	TSU:STO	Stop Condition Setup Time	100 kHz mode	4.7	—	μs	
			400 kHz mode	0.6	—	μs	
			1 MHz mode ⁽¹⁾	0.6	—	μs	
IS34	THD:STO	Stop Condition Hold Time	100 kHz mode	4000	—	ns	
			400 kHz mode	600	—	ns	
			1 MHz mode ⁽¹⁾	250	—	ns	
IS40	TAA:SCL	Output Valid From Clock	100 kHz mode	0	3500	ns	
			400 kHz mode	0	1000	ns	
			1 MHz mode ⁽¹⁾	0	350	ns	
IS45	TBF:SDA	Bus Free Time	100 kHz mode	4.7	—	μs	Time the bus must be free before a new transmission can start
			400 kHz mode	1.3	—	μs	
			1 MHz mode ⁽¹⁾	0.5	—	μs	
IS50	Cb	Bus Capacitive Loading		—	400	pF	

Note 1: Maximum pin capacitance = 10 pF for all I2Cx pins (for 1 MHz mode only).

dsPIC33FJ06GS101/X02 and dsPIC33FJ16GSX02/X04

TABLE 24-40: 10-BIT HIGH-SPEED ADC MODULE SPECIFICATIONS

AC CHARACTERISTICS			Standard Operating Conditions (see Note 2): 3.0V and 3.6V (unless otherwise stated) Operating temperature $-40^{\circ}\text{C} \leq T_A \leq +85^{\circ}\text{C}$ for Industrial $-40^{\circ}\text{C} \leq T_A \leq +125^{\circ}\text{C}$ for Extended				
Param No.	Symbol	Characteristic	Min.	Typ.	Max.	Units	Conditions
Device Supply							
AD01	AVDD	Module VDD Supply	—	—	—	—	AVDD is internally connected to VDD; see Parameter DC10 in Table 24-4
AD02	AVSS	Module VSS Supply	—	—	—	—	AVSS is internally connected to VSS
Analog Input							
AD10	V _{INH-VINL}	Full-Scale Input Span	V _{SS}	—	V _{DD}	V	
AD11	V _{IN}	Absolute Input Voltage	AV _{SS}	—	AV _{DD}	V	
AD12	I _{AD}	Operating Current	—	8	—	mA	
AD13	—	Leakage Current	—	±0.6	—	µA	V _{INL} = AV _{SS} = 0V, AV _{DD} = 3.3V, Source Impedance = 100Ω
AD17	R _{IN}	Recommended Impedance Of Analog Voltage Source	—	—	100	Ω	
DC Accuracy @ 1.5 Msps							
AD20A	N _r	Resolution	10 Data Bits				
AD21A	INL	Integral Nonlinearity	-0.5	-0.3/+0.5	+1.2	LSb	
AD22A	DNL	Differential Nonlinearity	-0.9	±0.6	+0.9	LSb	
AD23A	GERR	Gain Error	13	15	22	LSb	
AD24A	E _{OFF}	Offset Error	6	7	8	LSb	
AD25A	—	Monotonicity ⁽¹⁾	—	—	—	—	Guaranteed
DC Accuracy @ 1.7 Msps							
AD20B	N _r	Resolution	10 Data Bits				
AD21B	INL	Integral Nonlinearity	-0.5	-0.4/+1.1	+1.8	LSb	
AD22B	DNL	Differential Nonlinearity	-1.0	±1.0	+1.5	LSb	
AD23B	GERR	Gain Error	13	15	22	LSb	
AD24B	E _{OFF}	Offset Error	6	7	8	LSb	
AD25B	—	Monotonicity ⁽¹⁾	—	—	—	—	Guaranteed
DC Accuracy @ 2.0 Msps							
AD20C	N _r	Resolution	10 Data Bits				
AD21C	INL	Integral Nonlinearity	-0.8	-0.5/+1.8	+2.8	LSb	
AD22C	DNL	Differential Nonlinearity	-1.0	-1.0/+1.8	+2.8	LSb	
AD23C	GERR	Gain Error	14	16	23	LSb	
AD24C	E _{OFF}	Offset Error	6	7	8	LSb	
AD25C	—	Monotonicity ⁽¹⁾	—	—	—	—	Guaranteed
Dynamic Performance							
AD30	THD	Total Harmonic Distortion	—	-73	—	dB	
AD31	SINAD	Signal to Noise and Distortion	—	58	—	dB	
AD32	SFDR	Spurious Free Dynamic Range	—	-73	—	dB	
AD33	F _{NYQ}	Input Signal Bandwidth	—	—	1	MHz	
AD34	ENOB	Effective Number of Bits	—	9.4	—	bits	

Note 1: The Analog-to-Digital conversion result never decreases with an increase in input voltage, and has no missing codes.

2: Module is functional at $V_{BOR} < V_{DD} < V_{DDMIN}$, but with degraded performance. Module functionality is tested but not characterized.

dsPIC33FJ06GS101/X02 and dsPIC33FJ16GSX02/X04

TABLE 24-41: 10-BIT, HIGH-SPEED ADC MODULE TIMING REQUIREMENTS

AC CHARACTERISTICS			Standard Operating Conditions (see Note 2): 3.0V to 3.6V (unless otherwise stated) Operating temperature -40°C ≤ TA ≤ +85°C for Industrial -40°C ≤ TA ≤ +125°C for Extended				
Param No.	Symbol	Characteristic	Min.	Typ ⁽¹⁾	Max.	Units	Conditions
Clock Parameters							
AD50b	TAD	ADC Clock Period	35.8	—	—	ns	
Conversion Rate							
AD55b	tCONV	Conversion Time	—	14 TAD	—	—	
AD56b	FCNV	Throughput Rate					
		Devices with Single SAR	—	—	2.0	Msp/s	
		Devices with Dual SARs	—	—	4.0	Msp/s	
Timing Parameters							
AD63b	tDPU	Time to Stabilize Analog Stage from ADC Off to ADC On	1.0	—	10	μs	

Note 1: These parameters are characterized but not tested in manufacturing.

Note 2: Module is functional at $V_{BOR} < V_{DD} < V_{DDMIN}$, but with degraded performance. Module functionality is tested but not characterized.

FIGURE 24-23: ANALOG-TO-DIGITAL CONVERSION TIMING PER INPUT



dsPIC33FJ06GS101/X02 and dsPIC33FJ16GSX02/X04

TABLE 24-42: COMPARATOR MODULE SPECIFICATIONS

DC CHARACTERISTICS			Standard Operating Conditions (see Note 2): 3.0V to 3.6V Operating temperature: $-40^{\circ}\text{C} \leq T_A \leq +85^{\circ}\text{C}$ for Industrial $-40^{\circ}\text{C} \leq T_A \leq +125^{\circ}\text{C}$ for Extended				
Param. No.	Symbol	Characteristic	Min	Typ	Max	Units	Comments
CM10	V _{IOFF}	Input Offset Voltage	-58	+14/-40	66	mV	
CM11	V _{ICM}	Input Common-Mode Voltage Range ⁽¹⁾	0	—	$AV_{DD} - 1.5$	V	
CM12	V _{GAIN}	Open Loop Gain ⁽¹⁾	90	—	—	db	
CM13	CMRR	Common-Mode Rejection Ratio ⁽¹⁾	70	—	—	db	
CM14	T _{RESP}	Large Signal Response	21	30	49	ns	V+ input step of 100 mv while V- input held at $AV_{DD}/2$. Delay measured from analog input pin to PWM output pin.

Note 1: Parameters are for design guidance only and are not tested in manufacturing.

Note 2: Module is functional at $V_{BOR} < V_{DD} < V_{DDMIN}$, but with degraded performance. Module functionality is tested but not characterized.

TABLE 24-43: DAC MODULE SPECIFICATIONS

AC and DC CHARACTERISTICS			Standard Operating Conditions (see Note 2): 3.0V to 3.6V Operating temperature: $-40^{\circ}\text{C} \leq T_A \leq +85^{\circ}\text{C}$ for Industrial $-40^{\circ}\text{C} \leq T_A \leq +125^{\circ}\text{C}$ for Extended				
Param. No.	Symbol	Characteristic	Min	Typ	Max	Units	Comments
DA01	EXTREF	External Voltage Reference ⁽¹⁾	0		$AV_{DD} - 1.6$	V	
DA08	INTREF	Internal Voltage Reference ⁽¹⁾	1.25	1.32	1.41	V	
DA02	CVRES	Resolution	10			Bits	
DA03	INL	Integral Nonlinearity Error	-7	-1	+7	LSB	$AV_{DD} = 3.3\text{V}$, $DACREF = (AV_{DD}/2)\text{V}$
DA04	DNL	Differential Nonlinearity Error	-5	-0.5	+5	LSB	
DA05	E _{OFF}	Offset Error	0.4	-0.8	2.6	%	
DA06	EG	Gain Error	0.4	-1.8	5.2	%	
DA07	T _{SET}	Settling Time ⁽¹⁾	711	1551	2100	nsec	Measured when range = 1 (high range), and CMREF<9:0> transitions from 0x1FF to 0x300.

Note 1: Parameters are for design guidance only and are not tested in manufacturing.

Note 2: Module is functional at $V_{BOR} < V_{DD} < V_{DDMIN}$, but with degraded performance. Module functionality is tested but not characterized.

dsPIC33FJ06GS101/X02 and dsPIC33FJ16GSX02/X04

TABLE 24-44: DAC OUTPUT BUFFER DC SPECIFICATIONS

DC CHARACTERISTICS			Standard Operating Conditions (see Note 1): 3.0V to 3.6V Operating temperature: -40°C ≤ TA ≤ +85°C for Industrial -40°C ≤ TA ≤ +125°C for Extended				
Param. No.	Symbol	Characteristic	Min	Typ	Max	Units	Comments
DA10	RLOAD	Resistive Output Load Impedance	3K	—	—	Ω	
DA11	CLOAD	Output Load Capacitance	—	20	35	pF	
DA12	IOUT	Output Current Drive Strength	-1740	±1400	+1770	μA	Sink and source
DA13	VRANGE	Full Output Drive Strength Voltage Range	AVSS + 250 mV	—	AVDD – 900 mV	V	
DA14	VLRANGE	Output Drive Voltage Range at Reduced Current Drive of 50 μA	AVSS + 50 mV	—	AVDD – 500 mV	V	
DA15	IDD	Current Consumed when Module is Enabled, High-Power Mode	369	626	948	μA	Module will always consume this current even if no load is connected to the output
DA16	ROUTON	Output Impedance when Module is Enabled	—	1200	—	Ω	

Note 1: Module is functional at $V_{BOR} < V_{DD} < V_{DDMIN}$, but with degraded performance. Module functionality is tested but not characterized.

dsPIC33FJ06GS101/X02 and dsPIC33FJ16GSX02/X04

NOTES:

dsPIC33FJ06GS101/X02 and dsPIC33FJ16GSX02/X04

25.0 HIGH-TEMPERATURE ELECTRICAL CHARACTERISTICS

This section provides an overview of dsPIC33FJ06GS101/X02 and dsPIC33FJ16GSX02/X04 electrical characteristics for devices operating in an ambient temperature range of -40°C to +150°C.

Note: Programming of the Flash memory is not allowed above +125°C.

The specifications between -40°C to +150°C are identical to those shown in [Section 24.0 “Electrical Characteristics”](#) for operation between -40°C to +125°C, with the exception of the parameters listed in this section.

Parameters in this section begin with an H, which denotes High temperature. For example, Parameter [DC10](#) in [Section 24.0 “Electrical Characteristics”](#) is the Industrial and Extended temperature equivalent of HDC10.

Absolute maximum ratings for the dsPIC33FJ06GS101/X02 and dsPIC33FJ16GSX02/X04 high-temperature devices are listed below. Exposure to these maximum rating conditions for extended periods can affect device reliability. Functional operation of the device at these or any other conditions above the parameters indicated in the operation listings of this specification is not implied.

Absolute Maximum Ratings⁽¹⁾

Ambient temperature under bias ⁽³⁾	-40°C to +150°C
Storage temperature	-65°C to +160°C
Voltage on VDD with respect to VSS	-0.3V to +4.0V
Voltage on any pin that is not 5V tolerant with respect to VSS ⁽⁴⁾	-0.3V to (VDD + 0.3V)
Voltage on any 5V tolerant pin with respect to VSS when VDD < 3.0V ⁽⁴⁾	-0.3V to (VDD + 0.3V)
Voltage on any 5V tolerant pin with respect to VSS when VDD ≥ 3.0V ⁽⁴⁾	-0.3V to 5.6V
Maximum current out of VSS pin	60 mA
Maximum current into VDD pin ⁽²⁾	60 mA
Maximum junction temperature	+155°C
Maximum current sourced/sunk by any 4x I/O pin	4 mA
Maximum current sourced/sunk by any 8x I/O pin	8 mA
Maximum current sourced/sunk by any 16x I/O pin	16 mA
Maximum current sunk by all ports combined	180 mA
Maximum current sourced by all ports combined ⁽²⁾	180 mA

Note 1: Stresses above those listed under “Absolute Maximum Ratings” can cause permanent damage to the device. This is a stress rating only, and functional operation of the device at those or any other conditions above those indicated in the operation listings of this specification is not implied. Exposure to maximum rating conditions for extended periods can affect device reliability.

2: Maximum allowable current is a function of device maximum power dissipation (see [Table 25-2](#)).

3: AEC-Q100 reliability testing for devices intended to operate at 150°C is 1,000 hours. Any design in which the total operating time from 125°C to 150°C will be greater than 1,000 hours is not warranted without prior written approval from Microchip Technology Inc.

4: Refer to the “[Pin Diagrams](#)” section for 5V tolerant pins.

dsPIC33FJ06GS101/X02 and dsPIC33FJ16GSX02/X04

25.1 High-Temperature DC Characteristics

TABLE 25-1: OPERATING MIPS VS. VOLTAGE

Characteristic	VDD Range (in Volts)	Temperature Range (in °C)	Max MIPS
			dsPIC33FJ06GS101/X02 and dsPIC33FJ16GSX02/X04
—	3.0V to 3.6V ⁽¹⁾	-40°C to +150°C	20

Note 1: Overall functional device operation at $V_{BORMIN} < V_{DD} < V_{DDMIN}$ is tested but not characterized. All device analog modules such as the ADC, etc., will function but with degraded performance below V_{DDMIN} . Refer to Parameter **BO10** in [Table 24-11](#) for BOR values.

TABLE 25-2: THERMAL OPERATING CONDITIONS

Rating	Symbol	Min	Typ	Max	Unit
High-Temperature Devices					
Operating Junction Temperature Range	TJ	-40	—	+155	°C
Operating Ambient Temperature Range	TA	-40	—	+150	°C
Power Dissipation: Internal chip power dissipation: $P_{INT} = V_{DD} \times (I_{DD} - \Sigma I_{OH})$ I/O Pin Power Dissipation: $I/O = \Sigma (\{V_{DD} - V_{OH}\} \times I_{OH}) + \Sigma (V_{OL} \times I_{OL})$	PD	P _{INT} + P _{I/O}			W
Maximum Allowed Power Dissipation	PD _{MAX}	$(T_J - T_A)/\theta_{JA}$			W

TABLE 25-3: DC TEMPERATURE AND VOLTAGE SPECIFICATIONS

DC CHARACTERISTICS			Standard Operating Conditions: 3.0V to 3.6V (unless otherwise stated) Operating temperature $-40^\circ\text{C} \leq T_A \leq +150^\circ\text{C}$ for High Temperature				
Parameter No.	Symbol	Characteristic	Min	Typ	Max	Units	Conditions
Operating Voltage							
HDC10	Supply Voltage						
	VDD	—	3.0	3.3	3.6	V	-40°C to +150°C

dsPIC33FJ06GS101/X02 and dsPIC33FJ16GSX02/X04

TABLE 25-4: DC CHARACTERISTICS: POWER-DOWN CURRENT (IPD)

DC CHARACTERISTICS			Standard Operating Conditions: 3.0V to 3.6V (unless otherwise stated) Operating temperature $-40^{\circ}\text{C} \leq T_A \leq +150^{\circ}\text{C}$ for High Temperature			
Parameter No.	Typical ⁽¹⁾	Max	Units	Conditions		
Power-Down Current (IPD)^(2,4)						
HDC60e	1000	2000	μA	+150°C	3.3V	Base Power-Down Current
HDC61c	100	110	μA	+150°C	3.3V	Watchdog Timer Current: ΔIWDT ⁽³⁾

Note 1: Data in the Typical column is at 3.3V, +25°C unless otherwise stated.

2: IPD (Sleep) current is measured as follows:

- CPU core is off, oscillator is configured in EC mode and external clock active, OSC1 is driven with external square wave from rail-to-rail (EC clock overshoot/undershoot < 250 mV required)
- CLKO is configured as an I/O input pin in the Configuration Word
- All I/O pins are configured as inputs and pulled to Vss
- MCLR = VDD, WDT and FSCM are disabled
- All peripheral modules are disabled (PMDx bits are all ones)
- The VREGS bit (RCON<8>) = 0 (i.e., core regulator is set to stand-by while the device is in Sleep mode)
- JTAG disabled

3: The Δ current is the additional current consumed when the WDT module is enabled. This current should be added to the base IPD current.

4: These currents are measured on the device containing the most memory in this family.

dsPIC33FJ06GS101/X02 and dsPIC33FJ16GSX02/X04

TABLE 25-5: DC CHARACTERISTICS: I/O PIN OUTPUT SPECIFICATIONS

DC CHARACTERISTICS			Standard Operating Conditions: 3.0V to 3.6V (unless otherwise stated) Operating temperature $-40^{\circ}\text{C} \leq T_A \leq +150^{\circ}\text{C}$ for High Temperature				
Param.	Symbol	Characteristic	Min.	Typ.	Max.	Units	Conditions
DO10	VOL	Output Low Voltage I/O Pins: 4x Sink Driver Pins – RA0-RA2, RB0-RB2, RB5- RB10, RB15, RC1, RC2, RC9, RC10	—	—	0.4	V	$I_{OL} \leq 3.6 \text{ mA}$, $V_{DD} = 3.3\text{V}$ See Note 1
		Output Low Voltage I/O Pins: 8x Sink Driver Pins – RC0, RC3-RC8, RC11-RC13	—	—	0.4	V	$I_{OL} \leq 6 \text{ mA}$, $V_{DD} = 3.3\text{V}$ See Note 1
		Output Low Voltage I/O Pins: 16x Sink Driver Pins – RA3, RA4, RB3, RB4, RB11-RB14	—	—	0.4	V	$I_{OL} \leq 12 \text{ mA}$, $V_{DD} = 3.3\text{V}$ See Note 1
DO20	VOH	Output High Voltage I/O Pins: 4x Source Driver Pins – RA0-RA2, RB0-RB2, RB5- RB10, RB15, RC1, RC2, RC9, RC10	2.4	—	—	V	$I_{OL} \geq -4 \text{ mA}$, $V_{DD} = 3.3\text{V}$ See Note 1
		Output High Voltage I/O Pins: 8x Source Driver Pins – RC0, RC3-RC8, RC11-RC13	2.4	—	—	V	$I_{OL} \geq -8 \text{ mA}$, $V_{DD} = 3.3\text{V}$ See Note 1
		Output High Voltage I/O Pins: 16x Source Driver Pins – RA3, RA4, RB3, RB4, RB11-RB14	2.4	—	—	V	$I_{OL} \geq -16 \text{ mA}$, $V_{DD} = 3.3\text{V}$ See Note 1
DO20A	VOH1	Output High Voltage I/O Pins: 4x Source Driver Pins – RA0-RA2, RB0-RB2, RB5- RB10, RB15, RC1, RC2, RC9, RC10	1.5	—	—	V	$I_{OH} \geq -3.9 \text{ mA}$, $V_{DD} = 3.3\text{V}$ See Note 1
			2.0	—	—		$I_{OH} \geq -3.7 \text{ mA}$, $V_{DD} = 3.3\text{V}$ See Note 1
			3.0	—	—		$I_{OH} \geq -2 \text{ mA}$, $V_{DD} = 3.3\text{V}$ See Note 1
		Output High Voltage I/O Pins: 8x Source Driver Pins – RC0, RC3-RC8, RC11-RC13	1.5	—	—	V	$I_{OH} \geq -7.5 \text{ mA}$, $V_{DD} = 3.3\text{V}$ See Note 1
			2.0	—	—		$I_{OH} \geq -6.8 \text{ mA}$, $V_{DD} = 3.3\text{V}$ See Note 1
			3.0	—	—		$I_{OH} \geq -3 \text{ mA}$, $V_{DD} = 3.3\text{V}$ See Note 1
	Output High Voltage I/O Pins: 16x Source Driver Pins – RA3, RA4, RB3, RB4, RB11-RB14	1.5	—	—	V	$I_{OH} \geq -15 \text{ mA}$, $V_{DD} = 3.3\text{V}$ See Note 1	
		2.0	—	—		$I_{OH} \geq -14 \text{ mA}$, $V_{DD} = 3.3\text{V}$ See Note 1	
		3.0	—	—		$I_{OH} \geq -7 \text{ mA}$, $V_{DD} = 3.3\text{V}$ See Note 1	

Note 1: Parameters are characterized, but not tested.

dsPIC33FJ06GS101/X02 and dsPIC33FJ16GSX02/X04

TABLE 25-6: DC CHARACTERISTICS: PROGRAM MEMORY

DC CHARACTERISTICS			Standard Operating Conditions: 3.0V to 3.6V (unless otherwise stated) Operating temperature $-40^{\circ}\text{C} \leq T_A \leq +150^{\circ}\text{C}$ for High Temperature				
Param No.	Symbol	Characteristic ⁽¹⁾	Min	Typ	Max	Units	Conditions
		Program Flash Memory					
HD130	EP	Cell Endurance	10,000	—	—	E/W	-40°C to $+150^{\circ}\text{C}$ ⁽²⁾ 1000 E/W cycles or less and no other specifications are violated
HD134	TRETD	Characteristic Retention	20	—	—	Year	

- Note 1:** These parameters are assured by design, but are not characterized or tested in manufacturing.
Note 2: Programming of the Flash memory is not allowed above $+125^{\circ}\text{C}$.

dsPIC33FJ06GS101/X02 and dsPIC33FJ16GSX02/X04

25.2 AC Characteristics and Timing Parameters

The information contained in this section defines dsPIC33FJ06GS101/X02 and dsPIC33FJ16GSX02/X04 AC characteristics and timing parameters for high-temperature devices. However, all AC timing specifications in this section are the same as those in [Section 24.2 “AC Characteristics and Timing Parameters”](#), with the exception of the parameters listed in this section.

Parameters in this section begin with an H, which denotes High temperature. For example, Parameter OS53 in [Section 24.2 “AC Characteristics and Timing Parameters”](#) is the Industrial and Extended temperature equivalent of HOS53.

TABLE 25-7: TEMPERATURE AND VOLTAGE SPECIFICATIONS – AC

AC CHARACTERISTICS	Standard Operating Conditions: 3.0V to 3.6V (unless otherwise stated) Operating temperature $-40^{\circ}\text{C} \leq T_A \leq +150^{\circ}\text{C}$ for High Temperature Operating voltage V_{DD} range as described in Table 25-1 .
---------------------------	--

FIGURE 25-1: LOAD CONDITIONS FOR DEVICE TIMING SPECIFICATIONS

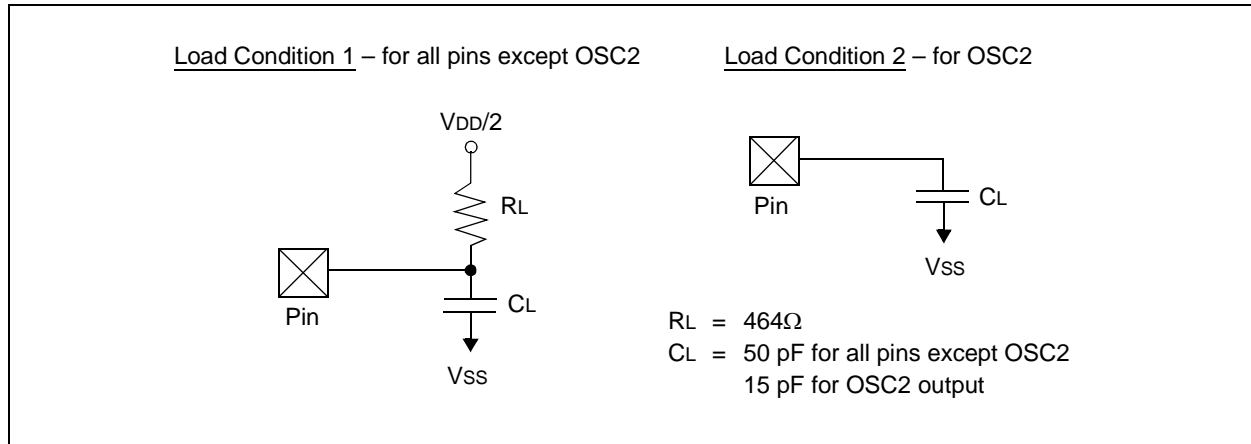

TABLE 25-8: PLL CLOCK TIMING SPECIFICATIONS

AC CHARACTERISTICS		Standard Operating Conditions: 3.0V to 3.6V (unless otherwise stated) Operating temperature $-40^{\circ}\text{C} \leq T_A \leq +150^{\circ}\text{C}$ for High Temperature					
Param No.	Symbol	Characteristic	Min	Typ	Max	Units	Conditions
HOS53	DCLK	CLKO Stability (Jitter) ⁽¹⁾	-5	0.5	5	%	Measured over 100 ms period

Note 1: These parameters are characterized, but are not tested in manufacturing.

dsPIC33FJ06GS101/X02 and dsPIC33FJ16GSX02/X04

TABLE 25-9: SPIx MASTER MODE (CKE = 0) TIMING REQUIREMENTS

AC CHARACTERISTICS		Standard Operating Conditions: 3.0V to 3.6V (unless otherwise stated) Operating temperature $-40^{\circ}\text{C} \leq T_A \leq +150^{\circ}\text{C}$ for High Temperature					
Param No.	Symbol	Characteristic ⁽¹⁾	Min	Typ	Max	Units	Conditions
HSP35	Tsch2doV, TscL2doV	SDOx Data Output Valid after SCKx Edge	—	10	25	ns	
HSP40	TdiV2scH, TdiV2scL	Setup Time of SDIx Data Input to SCKx Edge	28	—	—	ns	
HSP41	Tsch2diL, TscL2diL	Hold Time of SDIx Data Input to SCKx Edge	35	—	—	ns	

Note 1: These parameters are characterized but not tested in manufacturing.

TABLE 25-10: SPIx MODULE MASTER MODE (CKE = 1) TIMING REQUIREMENTS

AC CHARACTERISTICS		Standard Operating Conditions: 3.0V to 3.6V (unless otherwise stated) Operating temperature $-40^{\circ}\text{C} \leq T_A \leq +150^{\circ}\text{C}$ for High Temperature					
Param No.	Symbol	Characteristic ⁽¹⁾	Min	Typ	Max	Units	Conditions
HSP35	Tsch2doV, TscL2doV	SDOx Data Output Valid after SCKx Edge	—	10	25	ns	
HSP36	TdoV2sc, TdoV2scL	SDOx Data Output Setup to First SCKx Edge	35	—	—	ns	
HSP40	TdiV2scH, TdiV2scL	Setup Time of SDIx Data Input to SCKx Edge	28	—	—	ns	
HSP41	Tsch2diL, TscL2diL	Hold Time of SDIx Data Input to SCKx Edge	35	—	—	ns	

Note 1: These parameters are characterized but not tested in manufacturing.

dsPIC33FJ06GS101/X02 and dsPIC33FJ16GSX02/X04

TABLE 25-11: SPIx MODULE SLAVE MODE (CKE = 0) TIMING REQUIREMENTS

AC CHARACTERISTICS		Standard Operating Conditions: 3.0V to 3.6V (unless otherwise stated) Operating temperature $-40^{\circ}\text{C} \leq T_A \leq +150^{\circ}\text{C}$ for High Temperature					
Param No.	Symbol	Characteristic ⁽¹⁾	Min	Typ	Max	Units	Conditions
HSP35	Tsch2doV, TscL2doV	SDOx Data Output Valid after SCKx Edge	—	—	35	ns	
HSP40	TdiV2sch, TdiV2scL	Setup Time of SDIx Data Input to SCKx Edge	25	—	—	ns	
HSP41	Tsch2diL, TscL2diL	Hold Time of SDIx Data Input to SCKx Edge	25	—	—	ns	
HSP51	TssH2doZ	$\overline{\text{SS}}_x \uparrow$ to SDOx Output High-Impedance	15	—	55	ns	See Note 2

Note 1: These parameters are characterized but not tested in manufacturing.

2: Assumes 50 pF load on all SPIx pins.

TABLE 25-12: SPIx MODULE SLAVE MODE (CKE = 1) TIMING REQUIREMENTS

AC CHARACTERISTICS		Standard Operating Conditions: 3.0V to 3.6V (unless otherwise stated) Operating temperature $-40^{\circ}\text{C} \leq T_A \leq +150^{\circ}\text{C}$ for High Temperature					
Param No.	Symbol	Characteristic ⁽¹⁾	Min	Typ	Max	Units	Conditions
HSP35	Tsch2doV, TscL2doV	SDOx Data Output Valid after SCKx Edge	—	—	35	ns	
HSP40	TdiV2sch, TdiV2scL	Setup Time of SDIx Data Input to SCKx Edge	25	—	—	ns	
HSP41	Tsch2diL, TscL2diL	Hold Time of SDIx Data Input to SCKx Edge	25	—	—	ns	
HSP51	TssH2doZ	$\overline{\text{SS}}_x \uparrow$ to SDOx Output High-Impedance	15	—	55	ns	See Note 2
HSP60	TssL2doV	SDOx Data Output Valid after $\overline{\text{SS}}_x$ Edge	—	—	55	ns	

Note 1: These parameters are characterized but not tested in manufacturing.

2: Assumes 50 pF load on all SPIx pins.

dsPIC33FJ06GS101/X02 and dsPIC33FJ16GSX02/X04

26.0 50 MIPS ELECTRICAL CHARACTERISTICS

This section provides an overview of dsPIC33FJ06GS101/X02 and dsPIC33FJ16GSX02/X04 electrical characteristics for devices operating at 50 MIPS.

The specifications for 50 MIPS are identical to those shown in [Section 24.0 “Electrical Characteristics”](#), with the exception of the parameters listed in this section.

Parameters in this section begin with the letter “M”, which denotes 50 MIPS operation. For example, Parameter DC29a in [Section 24.0 “Electrical Characteristics”](#), is the up to 40 MIPS operation equivalent of MDC29a.

Absolute maximum ratings for the dsPIC33FJ06GS101/X02 and dsPIC33FJ16GSX02/X04 50 MIPS devices are listed below. Exposure to these maximum rating conditions for extended periods can affect device reliability. Functional operation of the device at these or any other conditions above the parameters indicated in the operation listings of this specification is not implied.

Absolute Maximum Ratings⁽¹⁾

Ambient temperature under bias	-40°C to +85°C
Storage temperature	-65°C to +150°C
Voltage on VDD with respect to VSS	-0.3V to +4.0V
Voltage on any pin that is not 5V tolerant, with respect to VSS ⁽³⁾	-0.3V to (VDD + 0.3V)
Voltage on any 5V tolerant pin with respect to VSS, when VDD ≥ 3.0V ⁽³⁾	-0.3V to +5.6V
Voltage on any 5V tolerant pin with respect to VSS, when VDD < 3.0V ⁽³⁾	-0.3V to (VDD + 0.3V)
Maximum current out of VSS pin	300 mA
Maximum current into VDD pin ⁽²⁾	250 mA
Maximum current sourced/sunk by any 4x I/O pin	15 mA
Maximum current sourced/sunk by any 8x I/O pin	25 mA
Maximum current sourced/sunk by any 16x I/O pin	45 mA
Maximum current sunk by all ports	200 mA
Maximum current sourced by all ports ⁽²⁾	200mA

Note 1: Stresses above those listed under “Absolute Maximum Ratings” may cause permanent damage to the device. This is a stress rating only, and functional operation of the device at those or any other conditions above those indicated in the operation listings of this specification is not implied. Exposure to maximum rating conditions for extended periods may affect device reliability.

2: Maximum allowable current is a function of device maximum power dissipation (see [Table 24-2](#)).

3: See the “[Pin Diagrams](#)” section for 5V tolerant pins.

dsPIC33FJ06GS101/X02 and dsPIC33FJ16GSX02/X04

26.1 DC Characteristics

TABLE 26-1: OPERATING MIPS VS. VOLTAGE

Characteristic	VDD Range (in Volts)	Temp Range (in °C)	Max MIPS
			dsPIC33FJ06GS101/X02 and dsPIC33FJ16GSX02/X04
—	3.0-3.6V ⁽¹⁾	-40°C to +85°C	50

Note 1: Overall functional device operation at $V_{BORMIN} < V_{DD} < V_{DDMIN}$ is tested but not characterized. All device analog modules, such as the ADC, etc., will function but with degraded performance below V_{DDMIN} . Refer to Parameter [BO10](#) in [Table 24-11](#) for BOR values.

TABLE 26-2: DC CHARACTERISTICS: OPERATING CURRENT (IDD)

DC CHARACTERISTICS			Standard Operating Conditions: 3.0V to 3.6V (unless otherwise stated) Operating temperature $-40^{\circ}\text{C} \leq T_A \leq +85^{\circ}\text{C}$ for Industrial			
Parameter No.	Typical	Max	Units	Conditions		
Operating Current (IDD)⁽¹⁾						
MDC29d	105	125	mA	-40°C	3.3V	50 MIPS
MDC29a	105	125	mA	+25°C		
MDC29b	105	125	mA	+85°C		

Note 1: I_{DD} is primarily a function of the operating voltage and frequency. Other factors, such as I/O pin loading and switching rate, oscillator type, internal code execution pattern and temperature, also have an impact on the current consumption. The test conditions for all I_{DD} measurements are as follows:

- Oscillator is configured in EC mode with PLL, OSC1 is driven with external square wave from rail-to-rail (EC clock overshoot/undershoot < 250 mV required)
- CLKO is configured as an I/O input pin in the Configuration Word
- All I/O pins are configured as inputs and pulled to V_{SS}
- $\overline{\text{MCLR}} = V_{DD}$, WDT and FSCM are disabled
- CPU, SRAM, program memory and data memory are operational
- No peripheral modules are operating; however, every peripheral is being clocked (all PMDx bits are zeroed)
- CPU executing `while(1)` statement
- JTAG is disabled

dsPIC33FJ06GS101/X02 and dsPIC33FJ16GSX02/X04

TABLE 26-3: DC CHARACTERISTICS: IDLE CURRENT (IDLE)

DC CHARACTERISTICS			Standard Operating Conditions: 3.0V to 3.6V (unless otherwise stated) Operating temperature $-40^{\circ}\text{C} \leq T_A \leq +85^{\circ}\text{C}$ for Industrial		
Parameter No.	Typical	Max	Units	Conditions	
Idle Current (IDLE): Core Off, Clock On Base Current⁽¹⁾					
MDC45d	64	105	mA	-40°C	3.3V 50 MIPS
MDC45a	64	105	mA	+25°C	
MDC45b	64	105	mA	+85°C	

Note 1: Base Idle current (IDLE) is measured as follows:

- CPU core is off, oscillator is configured in EC mode and external clock active, OSC1 is driven with external square wave from rail-to-rail (EC clock overshoot/undershoot < 250 mV required)
- CLKO is configured as an I/O input pin in the Configuration Word
- All I/O pins are configured as inputs and pulled to VSS
- $\overline{\text{MCLR}} = V_{\text{DD}}$, WDT and FSCM are disabled
- No peripheral modules are operating; however, every peripheral is being clocked (all PMDx bits are zeroed)
- The NVMSIDL bit (NVMCON<12>) = 1 (i.e., Flash regulator is set to standby while the device is in Idle mode)
- JTAG is disabled

dsPIC33FJ06GS101/X02 and dsPIC33FJ16GSX02/X04

TABLE 26-4: DC CHARACTERISTICS: DOZE CURRENT (IDOZE)⁽¹⁾

DC CHARACTERISTICS			Standard Operating Conditions: 3.0V to 3.6V (unless otherwise stated) Operating temperature $-40^{\circ}\text{C} \leq T_A \leq +85^{\circ}\text{C}$ for Industrial				
Parameter No.	Typical	Max	Doze Ratio	Units	Conditions		
MDC74a	80	105	1:2	mA	-40°C	3.3V	50 MIPS
MDC74f	65	105	1:64	mA			
MDC74g	65	105	1:128	mA			
MDC75a	81	105	1:2	mA	+25°C	3.3V	50 MIPS
MDC75f	65	105	1:64	mA			
MDC75g	65	105	1:128	mA			
MDC76a	81	105	1:2	mA	+85°C	3.3V	50 MIPS
MDC76f	65	105	1:64	mA			
MDC76g	65	105	1:128	mA			

Note 1: IDOZE is primarily a function of the operating voltage and frequency. Other factors, such as I/O pin loading and switching rate, oscillator type, internal code execution pattern and temperature, also have an impact on the current consumption. The test conditions for all IDOZE measurements are as follows:

- Oscillator is configured in EC mode and external clock active, OSC1 is driven with external square wave from rail-to-rail (EC clock overshoot/undershoot < 250 mV required)
- CLKO is configured as an I/O input pin in the Configuration Word
- All I/O pins are configured as inputs and pulled to V_{SS}
- $\overline{\text{MCLR}} = V_{\text{DD}}$, WDT and FSCM are disabled
- CPU, SRAM, program memory and data memory are operational
- No peripheral modules are operating; however, every peripheral is being clocked (all PMD_x bits are zeroed)
- CPU executing `while(1)` statement
- JTAG is disabled

dsPIC33FJ06GS101/X02 and dsPIC33FJ16GSX02/X04

26.2 AC Characteristics and Timing Parameters

This section defines the dsPIC33FJ06GS101/X02 and dsPIC33FJ16GSX02/X04 AC characteristics and timing parameters for 50 MIPS devices.

TABLE 26-5: EXTERNAL CLOCK TIMING REQUIREMENTS

AC CHARACTERISTICS			Standard Operating Conditions: 3.0V to 3.6V (unless otherwise stated) Operating temperature $-40^{\circ}\text{C} \leq T_A \leq +85^{\circ}\text{C}$ for Industrial				
Param No.	Symb	Characteristic	Min	Typ ⁽¹⁾	Max	Units	Conditions
MOS10	FIN	External CLKI Frequency (External clocks allowed only in EC and ECPLL modes)	DC	—	50	MHz	EC
		Oscillator Crystal Frequency	3.5 10	— —	10 50	MHz MHz	XT HS
MOS20	Tosc	Tosc = 1/Fosc	10	—	DC	ns	
MOS25	Tcy	Instruction Cycle Time ⁽²⁾	20	—	DC	ns	

Note 1: Data in “Typ” column is at 3.3V, +25°C unless otherwise stated.

- 2:** Instruction cycle period (Tcy) equals two times the input oscillator time base period. All specified values are based on characterization data for that particular oscillator type, under standard operating conditions, with the device executing code. Exceeding these specified limits may result in an unstable oscillator operation and/or higher than expected current consumption. All devices are tested to operate at “Min.” values with an external clock applied to the OSC1/CLKI pin. When an external clock input is used, the “Max.” cycle time limit is “DC” (no clock) for all devices.

TABLE 26-6: SIMPLE OCx/PWMx MODE TIMING REQUIREMENTS

AC CHARACTERISTICS			Standard Operating Conditions: 3.0V to 3.6V (unless otherwise stated) Operating temperature $-40^{\circ}\text{C} \leq T_A \leq +85^{\circ}\text{C}$ for Industrial				
Param No.	Symbol	Characteristic ⁽¹⁾	Min	Typ	Max	Units	Conditions
MOC15	TFD	Fault Input to PWMx I/O Change	—	—	Tcy + 10	ns	
MOC20	TFLT	Fault Input Pulse Width	Tcy + 10	—	—	ns	

Note 1: These parameters are characterized but not tested in manufacturing.

dsPIC33FJ06GS101/X02 and dsPIC33FJ16GSX02/X04

NOTES:

27.0 DC AND AC DEVICE CHARACTERISTICS GRAPHS

Note: The graphs provided following this note are a statistical summary based on a limited number of samples and are provided for design guidance purposes only. The performance characteristics listed herein are not tested or guaranteed. In some graphs, the data presented may be outside the specified operating range (e.g., outside specified power supply range) and therefore, outside the warranted range.

FIGURE 27-1: V_{OH} – 4x DRIVER PINS



FIGURE 27-3: V_{OH} – 16x DRIVER PINS

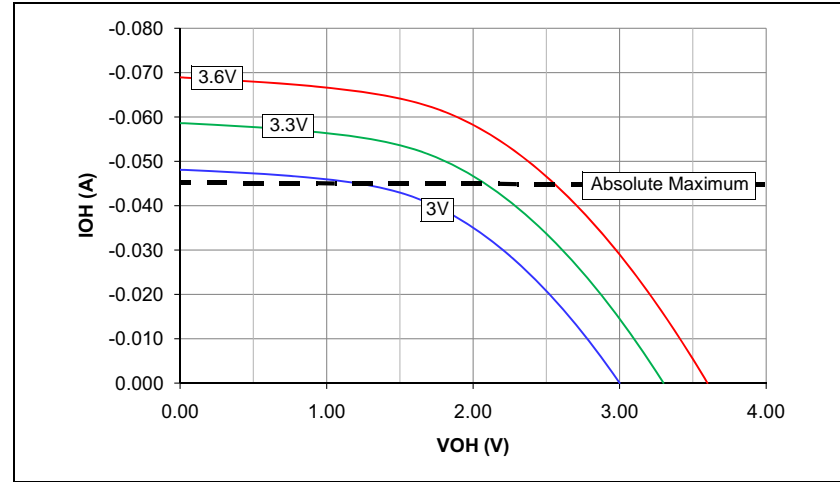

FIGURE 27-2: V_{OH} – 8x DRIVER PINS



FIGURE 27-4: VOL – 4x DRIVER PINS



FIGURE 27-6: VOL – 16x DRIVER PINS



FIGURE 27-5: VOL – 8x DRIVER PINS



FIGURE 27-7: TYPICAL I_{PD} CURRENT @ V_{DD} = 3.3V



FIGURE 27-9: TYPICAL I_{DOZE} CURRENT @ V_{DD} = 3.3V



FIGURE 27-8: TYPICAL I_{DD} CURRENT @ V_{DD} = 3.3V



FIGURE 27-10: TYPICAL I_{IDLE} CURRENT @ V_{DD} = 3.3V



FIGURE 27-11: TYPICAL FRC FREQUENCY @ V_{DD} = 3.3VFIGURE 27-13: TYPICAL INTREF @ V_{DD} = 3.3VFIGURE 27-12: TYPICAL LPRC FREQUENCY @ V_{DD} = 3.3V

dsPIC33FJ06GS101/X02 and dsPIC33FJ16GSX02/X04

28.0 PACKAGING INFORMATION

28.1 Package Marking Information

18-Lead SOIC (.300")



Example

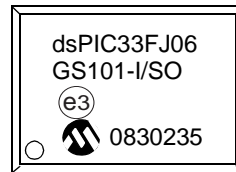

28-Lead SOIC



Example



28-Lead SPDIP



Example

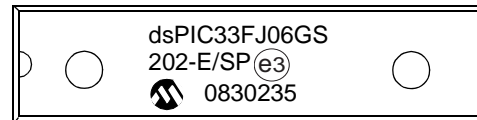

28-Lead QFN-S



Example



Legend:	XX...X	Customer-specific information
	Y	Year code (last digit of calendar year)
	YY	Year code (last 2 digits of calendar year)
	WW	Week code (week of January 1 is week '01')
	NNN	Alphanumeric traceability code
	(e3)	Pb-free JEDEC designator for Matte Tin (Sn)
	*	This package is Pb-free. The Pb-free JEDEC designator (e3) can be found on the outer packaging for this package.

Note: If the full Microchip part number cannot be marked on one line, it is carried over to the next line, thus limiting the number of available characters for customer-specific information.

dsPIC33FJ06GS101/X02 and dsPIC33FJ16GSX02/X04

28.1 Package Marking Information (Continued)

28-Lead UQFN



Example



44-Lead QFN



Example



44-Lead TQFP



Example



44-Lead VTLA (TLA)



Example



dsPIC33FJ06GS101/X02 and dsPIC33FJ16GSX02/X04

28.2 Package Details

18-Lead Plastic Small Outline (SO) - Wide, 7.50 mm Body [SOIC]

Note: For the most current package drawings, please see the Microchip Packaging Specification located at <http://www.microchip.com/packaging>



Microchip Technology Drawing C04-051C Sheet 1 of 2

dsPIC33FJ06GS101/X02 and dsPIC33FJ16GSX02/X04

18-Lead Plastic Small Outline (SO) - Wide, 7.50 mm Body [SOIC]

Note: For the most current package drawings, please see the Microchip Packaging Specification located at <http://www.microchip.com/packaging>

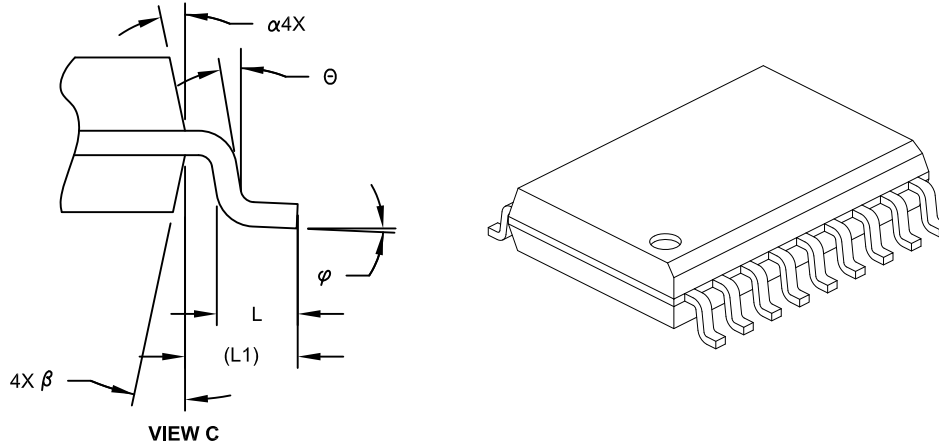

Dimension Limits	Units	MILLIMETERS		
		MIN	NOM	MAX
Number of Pins	N	18		
Pitch	e	1.27 BSC		
Overall Height	A	-	-	2.65
Molded Package Thickness	A2	2.05	-	-
Standoff §	A1	0.10	-	0.30
Overall Width	E	10.30 BSC		
Molded Package Width	E1	7.50 BSC		
Overall Length	D	11.55 BSC		
Chamfer (Optional)	h	0.25	-	0.75
Foot Length	L	0.40	-	1.27
Footprint	L1	1.40 REF		
Lead Angle	θ	0°	-	-
Foot Angle	φ	0°	-	8°
Lead Thickness	c	0.20	-	0.33
Lead Width	b	0.31	-	0.51
Mold Draft Angle Top	α	5°	-	15°
Mold Draft Angle Bottom	β	5°	-	15°

Notes:

- Pin 1 visual index feature may vary, but must be located within the hatched area.
- § Significant Characteristic
- Dimension D does not include mold flash, protrusions or gate burrs, which shall not exceed 0.15 mm per end. Dimension E1 does not include interlead flash or protrusion, which shall not exceed 0.25 mm per side.
- Dimensioning and tolerancing per ASME Y14.5M
 BSC: Basic Dimension. Theoretically exact value shown without tolerances.
 REF: Reference Dimension, usually without tolerance, for information purposes only.
- Datums A & B to be determined at Datum H.

Microchip Technology Drawing No. C04-051C Sheet 2 of 2

dsPIC33FJ06GS101/X02 and dsPIC33FJ16GSX02/X04

18-Lead Plastic Small Outline (SO) - Wide, 7.50 mm Body [SOIC]

Note: For the most current package drawings, please see the Microchip Packaging Specification located at <http://www.microchip.com/packaging>



RECOMMENDED LAND PATTERN

Dimension Limits	Units	MILLIMETERS		
		MIN	NOM	MAX
Contact Pitch	E	1.27 BSC		
Contact Pad Spacing	C		9.40	
Contact Pad Width	X			0.60
Contact Pad Length	Y			2.00
Distance Between Pads	Gx	0.67		
Distance Between Pads	G	7.40		

Notes:

1. Dimensioning and tolerancing per ASME Y14.5M

BSC: Basic Dimension. Theoretically exact value shown without tolerances.

Microchip Technology Drawing No. C04-2051A

dsPIC33FJ06GS101/X02 and dsPIC33FJ16GSX02/X04

28-Lead Plastic Small Outline (SO) - Wide, 7.50 mm Body [SOIC]

Note: For the most current package drawings, please see the Microchip Packaging Specification located at <http://www.microchip.com/packaging>

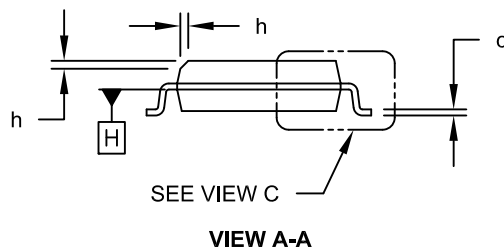

Microchip Technology Drawing C04-052C Sheet 1 of 2

dsPIC33FJ06GS101/X02 and dsPIC33FJ16GSX02/X04

28-Lead Plastic Small Outline (SO) - Wide, 7.50 mm Body [SOIC]

Note: For the most current package drawings, please see the Microchip Packaging Specification located at <http://www.microchip.com/packaging>



Dimension Limits	Units	MILLIMETERS		
		MIN	NOM	MAX
Number of Pins	N	28		
Pitch	e	1.27 BSC		
Overall Height	A	-	-	2.65
Molded Package Thickness	A2	2.05	-	-
Standoff §	A1	0.10	-	0.30
Overall Width	E	10.30 BSC		
Molded Package Width	E1	7.50 BSC		
Overall Length	D	17.90 BSC		
Chamfer (Optional)	h	0.25	-	0.75
Foot Length	L	0.40	-	1.27
Footprint	L1	1.40 REF		
Lead Angle	θ	0°	-	-
Foot Angle	φ	0°	-	8°
Lead Thickness	c	0.18	-	0.33
Lead Width	b	0.31	-	0.51
Mold Draft Angle Top	α	5°	-	15°
Mold Draft Angle Bottom	β	5°	-	15°

Notes:

- Pin 1 visual index feature may vary, but must be located within the hatched area.
- § Significant Characteristic
- Dimension D does not include mold flash, protrusions or gate burrs, which shall not exceed 0.15 mm per end. Dimension E1 does not include interlead flash or protrusion, which shall not exceed 0.25 mm per side.
- Dimensioning and tolerancing per ASME Y14.5M
BSC: Basic Dimension. Theoretically exact value shown without tolerances.
REF: Reference Dimension, usually without tolerance, for information purposes only.
- Datums A & B to be determined at Datum H.

Microchip Technology Drawing C04-052C Sheet 2 of 2

dsPIC33FJ06GS101/X02 and dsPIC33FJ16GSX02/X04

28-Lead Plastic Small Outline (SO) - Wide, 7.50 mm Body [SOIC]

Note: For the most current package drawings, please see the Microchip Packaging Specification located at <http://www.microchip.com/packaging>



RECOMMENDED LAND PATTERN

		Units	MILLIMETERS		
		Dimension Limits	MIN	NOM	MAX
Contact Pitch	E		1.27 BSC		
Contact Pad Spacing	C			9.40	
Contact Pad Width (X28)	X				0.60
Contact Pad Length (X28)	Y				2.00
Distance Between Pads	Gx		0.67		
Distance Between Pads	G		7.40		

Notes:

1. Dimensioning and tolerancing per ASME Y14.5M

BSC: Basic Dimension. Theoretically exact value shown without tolerances.

Microchip Technology Drawing No. C04-2052A

dsPIC33FJ06GS101/X02 and dsPIC33FJ16GSX02/X04

28-Lead Skinny Plastic Dual In-Line (SP) – 300 mil Body [SPDIP]

Note: For the most current package drawings, please see the Microchip Packaging Specification located at <http://www.microchip.com/packaging>



Dimension Limits	Units	INCHES		
		MIN	NOM	MAX
Number of Pins	N	28		
Pitch	e	.100 BSC		
Top to Seating Plane	A	–	–	.200
Molded Package Thickness	A2	.120	.135	.150
Base to Seating Plane	A1	.015	–	–
Shoulder to Shoulder Width	E	.290	.310	.335
Molded Package Width	E1	.240	.285	.295
Overall Length	D	1.345	1.365	1.400
Tip to Seating Plane	L	.110	.130	.150
Lead Thickness	c	.008	.010	.015
Upper Lead Width	b1	.040	.050	.070
Lower Lead Width	b	.014	.018	.022
Overall Row Spacing §	eB	–	–	.430

Notes:

- Pin 1 visual index feature may vary, but must be located within the hatched area.
- § Significant Characteristic.
- Dimensions D and E1 do not include mold flash or protrusions. Mold flash or protrusions shall not exceed .010" per side.
- Dimensioning and tolerancing per ASME Y14.5M.

BSC: Basic Dimension. Theoretically exact value shown without tolerances.

Microchip Technology Drawing C04-070B

dsPIC33FJ06GS101/X02 and dsPIC33FJ16GSX02/X04

28-Lead Plastic Quad Flat, No Lead Package (MM) – 6x6x0.9 mm Body [QFN-S] with 0.40 mm Contact Length

Note: For the most current package drawings, please see the Microchip Packaging Specification located at <http://www.microchip.com/packaging>



Dimension Limits	Units	MILLIMETERS		
		MIN	NOM	MAX
Number of Pins	N	28		
Pitch	e	0.65 BSC		
Overall Height	A	0.80	0.90	1.00
Standoff	A1	0.00	0.02	0.05
Contact Thickness	A3	0.20 REF		
Overall Width	E	6.00 BSC		
Exposed Pad Width	E2	3.65	3.70	4.70
Overall Length	D	6.00 BSC		
Exposed Pad Length	D2	3.65	3.70	4.70
Contact Width	b	0.23	0.38	0.43
Contact Length	L	0.30	0.40	0.50
Contact-to-Exposed Pad	K	0.20	–	–

Notes:

- Pin 1 visual index feature may vary, but must be located within the hatched area.
- Package is saw singulated.
- Dimensioning and tolerancing per ASME Y14.5M.

BSC: Basic Dimension. Theoretically exact value shown without tolerances.

REF: Reference Dimension, usually without tolerance, for information purposes only.

Microchip Technology Drawing C04-124B

dsPIC33FJ06GS101/X02 and dsPIC33FJ16GSX02/X04

28-Lead Plastic Quad Flat, No Lead Package (MM) – 6x6x0.9 mm Body [QFN-S] with 0.40 mm Contact Length

Note: For the most current package drawings, please see the Microchip Packaging Specification located at <http://www.microchip.com/packaging>

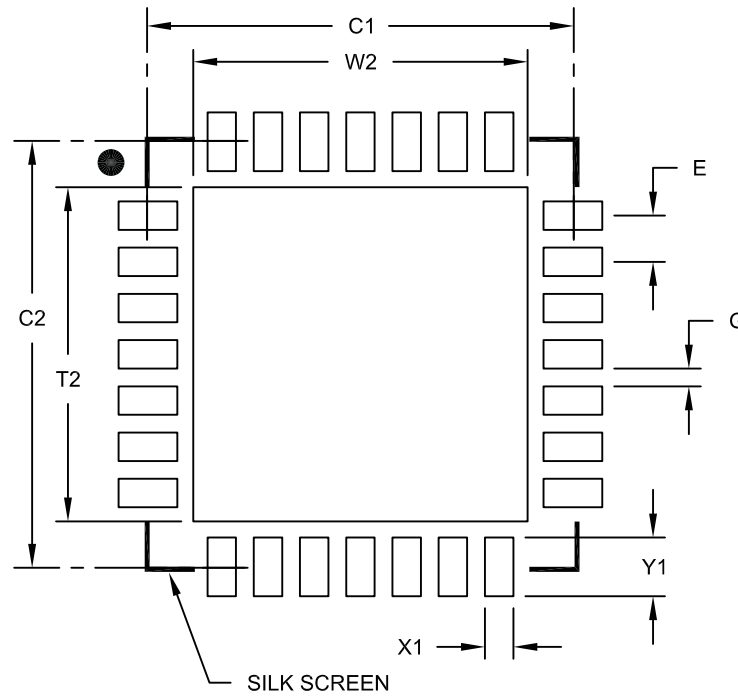

RECOMMENDED LAND PATTERN

Dimension Limits	Units	MILLIMETERS		
		MIN	NOM	MAX
Contact Pitch	E	0.65 BSC		
Optional Center Pad Width	W2			4.70
Optional Center Pad Length	T2			4.70
Contact Pad Spacing	C1		6.00	
Contact Pad Spacing	C2		6.00	
Contact Pad Width (X28)	X1			0.40
Contact Pad Length (X28)	Y1			0.85
Distance Between Pads	G	0.25		

Notes:

1. Dimensioning and tolerancing per ASME Y14.5M

BSC: Basic Dimension. Theoretically exact value shown without tolerances.

Microchip Technology Drawing No. C04-2124A

dsPIC33FJ06GS101/X02 and dsPIC33FJ16GSX02/X04

28-Lead Plastic Quad Flat, No Lead Package (MX) - 6x6x0.5mm Body [UQFN] Ultra-Thin with 0.40 x 0.60 mm Terminal Width/Length and Corner Anchors

Note: For the most current package drawings, please see the Microchip Packaging Specification located at <http://www.microchip.com/packaging>



Microchip Technology Drawing C04-0209B Sheet 1 of 2

dsPIC33FJ06GS101/X02 and dsPIC33FJ16GSX02/X04

28-Lead Plastic Quad Flat, No Lead Package (MX) - 6x6x0.5mm Body [UQFN] Ultra-Thin with 0.40 x 0.60 mm Terminal Width/Length and Corner Anchors

Note: For the most current package drawings, please see the Microchip Packaging Specification located at <http://www.microchip.com/packaging>



Units		MILLIMETERS		
Dimension Limits		MIN	NOM	MAX
Number of Pins	N	28		
Pitch	e	0.65 BSC		
Overall Height	A	0.40	0.50	0.60
Standoff	A1	0.00	0.02	0.05
Terminal Thickness	(A3)	0.127 REF		
Overall Width	E	6.00 BSC		
Exposed Pad Width	E2		4.00	
Overall Length	D	6.00 BSC		
Exposed Pad Length	D2		4.00	
Terminal Width	b	0.35	0.40	0.45
Corner Pad	b2	0.25	0.40	0.45
Terminal Length	L	0.55	0.60	0.65
Terminal-to-Exposed Pad	K	0.20	-	-

Notes:

1. Pin 1 visual index feature may vary, but must be located within the hatched area.
2. Package is saw singulated
3. Dimensioning and tolerancing per ASME Y14.5M
BSC: Basic Dimension. Theoretically exact value shown without tolerances.
REF: Reference Dimension, usually without tolerance, for information purposes only.
4. Outermost portions of corner structures may vary slightly.

Microchip Technology Drawing C04-0209B Sheet 2 of 2

dsPIC33FJ06GS101/X02 and dsPIC33FJ16GSX02/X04

28-Lead Plastic Quad Flat, No Lead Package (MX) - 6x6 mm Body [UQFN] With 0.60mm Contact Length And Corner Anchors

Note: For the most current package drawings, please see the Microchip Packaging Specification located at <http://www.microchip.com/packaging>



RECOMMENDED LAND PATTERN

Dimension Limits	Units	MILLIMETERS		
		MIN	NOM	MAX
Contact Pitch	E	0.65 BSC		
Optional Center Pad Width	W1			4.05
Optional Center Pad Length	T2			4.05
Contact Pad Spacing	C1		5.70	
Contact Pad Spacing	C2		5.70	
Contact Pad Width (X28)	X1			0.45
Contact Pad Length (X28)	Y1			1.00
Corner Pad Width (X4)	X2			0.90
Corner Pad Length (X4)	Y2			0.90
Distance Between Pads	G	0.20		

Notes:

1. Dimensioning and tolerancing per ASME Y14.5M

BSC: Basic Dimension. Theoretically exact value shown without tolerances.

Microchip Technology Drawing No. C04-2209B

dsPIC33FJ06GS101/X02 and dsPIC33FJ16GSX02/X04

44-Lead Plastic Quad Flat, No Lead Package (ML) - 8x8 mm Body [QFN]

Note: For the most current package drawings, please see the Microchip Packaging Specification located at <http://www.microchip.com/packaging>

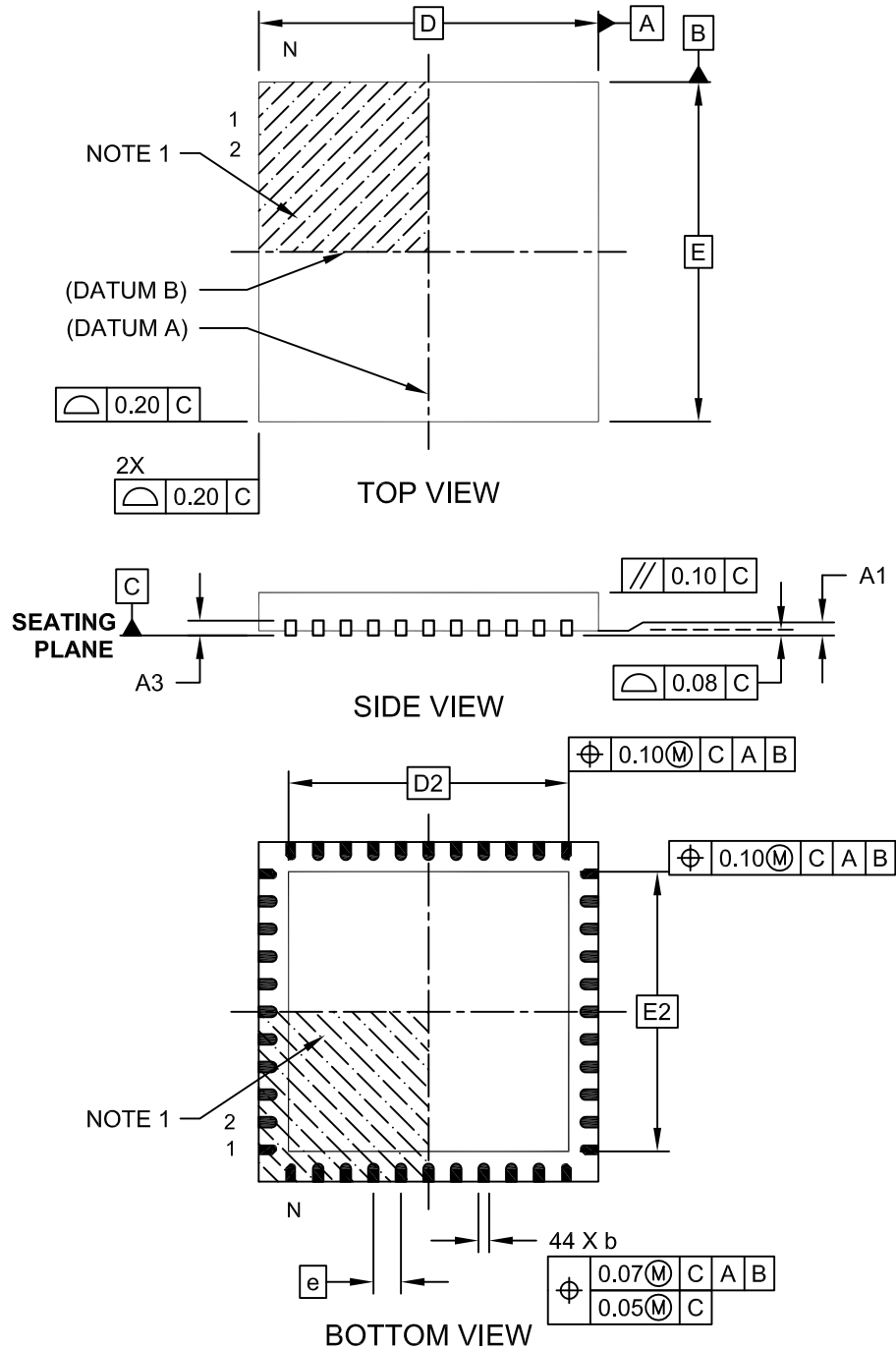

Microchip Technology Drawing C04-103C Sheet 1 of 2

dsPIC33FJ06GS101/X02 and dsPIC33FJ16GSX02/X04

44-Lead Plastic Quad Flat, No Lead Package (ML) - 8x8 mm Body [QFN]

Note: For the most current package drawings, please see the Microchip Packaging Specification located at <http://www.microchip.com/packaging>



Dimension Limits	Units	MILLIMETERS		
		MIN	NOM	MAX
Number of Pins	N	44		
Pitch	e	0.65 BSC		
Overall Height	A	0.80	0.90	1.00
Standoff	A1	0.00	0.02	0.05
Terminal Thickness	A3	0.20 REF		
Overall Width	E	8.00 BSC		
Exposed Pad Width	E2	6.25	6.45	6.60
Overall Length	D	8.00 BSC		
Exposed Pad Length	D2	6.25	6.45	6.60
Terminal Width	b	0.20	0.30	0.35
Terminal Length	L	0.30	0.40	0.50
Terminal-to-Exposed-Pad	K	0.20	-	-

Notes:

1. Pin 1 visual index feature may vary, but must be located within the hatched area.
2. Package is saw singulated
3. Dimensioning and tolerancing per ASME Y14.5M

BSC: Basic Dimension. Theoretically exact value shown without tolerances.

REF: Reference Dimension. usually without tolerance. for information purposes only.

Microchip Technology Drawing C04-103C Sheet 2 of 2

dsPIC33FJ06GS101/X02 and dsPIC33FJ16GSX02/X04

44-Lead Plastic Quad Flat, No Lead Package (ML) - 8x8 mm Body [QFN]

Note: For the most current package drawings, please see the Microchip Packaging Specification located at <http://www.microchip.com/packaging>



Dimension Limits	Units	MILLIMETERS		
		MIN	NOM	MAX
Contact Pitch	E	0.65 BSC		
Optional Center Pad Width	W2			6.60
Optional Center Pad Length	T2			6.60
Contact Pad Spacing	C1		8.00	
Contact Pad Spacing	C2		8.00	
Contact Pad Width (X44)	X1			0.35
Contact Pad Length (X44)	Y1			0.85
Distance Between Pads	G	0.25		

Notes:

1. Dimensioning and tolerancing per ASME Y14.5M

BSC: Basic Dimension. Theoretically exact value shown without tolerances.

Microchip Technology Drawing No. C04-2103B

dsPIC33FJ06GS101/X02 and dsPIC33FJ16GSX02/X04

44-Lead Plastic Thin Quad Flatpack (PT) – 10x10x1 mm Body, 2.00 mm [TQFP]

Note: For the most current package drawings, please see the Microchip Packaging Specification located at <http://www.microchip.com/packaging>



Dimension Limits	Units	MILLIMETERS		
		MIN	NOM	MAX
Number of Leads	N	44		
Lead Pitch	e	0.80 BSC		
Overall Height	A	–	–	1.20
Molded Package Thickness	A2	0.95	1.00	1.05
Standoff	A1	0.05	–	0.15
Foot Length	L	0.45	0.60	0.75
Footprint	L1	1.00 REF		
Foot Angle	ϕ	0°	3.5°	7°
Overall Width	E	12.00 BSC		
Overall Length	D	12.00 BSC		
Molded Package Width	E1	10.00 BSC		
Molded Package Length	D1	10.00 BSC		
Lead Thickness	c	0.09	–	0.20
Lead Width	b	0.30	0.37	0.45
Mold Draft Angle Top	α	11°	12°	13°
Mold Draft Angle Bottom	β	11°	12°	13°

Notes:

- Pin 1 visual index feature may vary, but must be located within the hatched area.
- Chamfers at corners are optional; size may vary.
- Dimensions D1 and E1 do not include mold flash or protrusions. Mold flash or protrusions shall not exceed 0.25 mm per side.
- Dimensioning and tolerancing per ASME Y14.5M.

BSC: Basic Dimension. Theoretically exact value shown without tolerances.

REF: Reference Dimension, usually without tolerance, for information purposes only.

Microchip Technology Drawing C04-076B

dsPIC33FJ06GS101/X02 and dsPIC33FJ16GSX02/X04

44-Lead Plastic Thin Quad Flatpack (PT) 10X10X1 mm Body, 2.00 mm Footprint [TQFP]

Note: For the most current package drawings, please see the Microchip Packaging Specification located at <http://www.microchip.com/packaging>



RECOMMENDED LAND PATTERN

Dimension Limits	Units	MILLIMETERS		
		MIN	NOM	MAX
Contact Pitch	E	0.80 BSC		
Contact Pad Spacing	C1		11.40	
Contact Pad Spacing	C2		11.40	
Contact Pad Width (X44)	X1			0.55
Contact Pad Length (X44)	Y1			1.50
Distance Between Pads	G	0.25		

Notes:

1. Dimensioning and tolerancing per ASME Y14.5M

BSC: Basic Dimension. Theoretically exact value shown without tolerances.

Microchip Technology Drawing No. C04-2076B

dsPIC33FJ06GS101/X02 and dsPIC33FJ16GSX02/X04

44-Terminal Very Thin Leadless Array Package (TL) – 6x6x0.9 mm Body With Exposed Pad [VTLA]

Note: For the most current package drawings, please see the Microchip Packaging Specification located at <http://www.microchip.com/packaging>

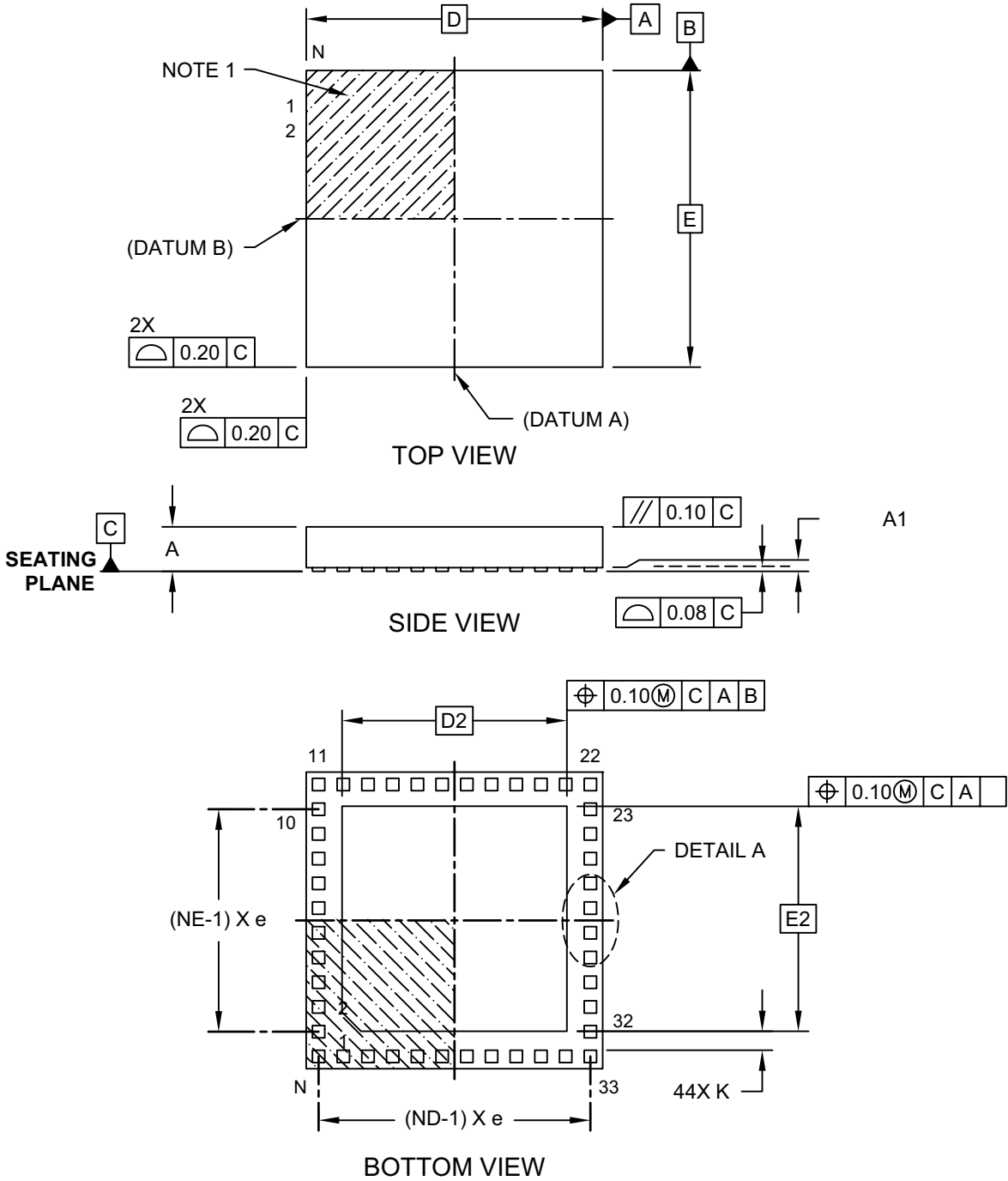

Microchip Technology Drawing C04-157D Sheet 1 of 2

dsPIC33FJ06GS101/X02 and dsPIC33FJ16GSX02/X04

44-Terminal Very Thin Leadless Array Package (TL) – 6x6x0.9 mm Body With Exposed Pad [VTLA]

Note: For the most current package drawings, please see the Microchip Packaging Specification located at <http://www.microchip.com/packaging>



Dimension	Units Limits	MILLIMETERS		
		MIN	NOM	MAX
Number of Terminals	N	44		
Number of Terminals per Side	ND	12		
Number of Terminals per Side	NE	10		
Pitch	e	0.50 BSC		
Overall Height	A	0.80	0.90	1.00
Standoff	A1	0.025	-	0.075
Overall Width	E	6.00 BSC		
Exposed Pad Width	E2	4.40	4.55	4.70
Overall Length	D	6.00 BSC		
Exposed Pad Length	D2	4.40	4.55	4.70
Terminal Width	b	0.20	0.25	0.30
Terminal Length	L	0.20	0.25	0.30
Terminal-to-Exposed Pad	K	0.20	-	-

Notes:

- Pin 1 visual index feature may vary, but must be located within the hatched area.
- Package is saw singulated.
- Dimensioning and tolerancing per ASME Y14.5M.
BSC: Basic Dimension. Theoretically exact value shown without tolerances.
REF: Reference Dimension, usually without tolerance, for information purposes only.

Microchip Technology Drawing C04-157D Sheet 2 of 2

dsPIC33FJ06GS101/X02 and dsPIC33FJ16GSX02/X04

44-Terminal Very Thin Leadless Array Package (TL) – 6x6x0.9 mm Body With Exposed Pad [VTLA]

Note: For the most current package drawings, please see the Microchip Packaging Specification located at <http://www.microchip.com/packaging>



RECOMMENDED LAND PATTERN

Units		MILLIMETERS		
Dimension Limits		MIN	NOM	MAX
Terminal Pitch	E	0.50 BSC		
Optional Center Pad Width	W2			4.70
Optional Center Pad Length	T2			4.70
Terminal Pad Spacing	C1		5.65	
Terminal Pad Spacing	C2		5.65	
Terminal Pad Width (X44)	X1			0.30
Terminal Pad Length (X44)	Y1			0.45
Distance Between Pads	(G1)	0.20 REF.		
Distance Between Pads	G	0.20		
Distance Between Pads	K1	0.267		

Notes:

1. Dimensioning and tolerancing per ASME Y14.5M

BSC: Basic Dimension. Theoretically exact value shown without tolerances.

Microchip Technology Drawing No. C04-2157A

dsPIC33FJ06GS101/X02 and dsPIC33FJ16GSX02/X04

APPENDIX A: REVISION HISTORY

Revision B (June 2008)

Revision A (January 2008)

This is the initial revision of this document.

This revision includes minor typographical and formatting changes throughout the data sheet text. In addition, redundant information was removed that is now available in the respective chapters of the *dsPIC33F/PIC24H Family Reference Manual*, which can be obtained from the Microchip web site (www.microchip.com).

The major changes are referenced by their respective section in the following table.

TABLE A-1: MAJOR SECTION UPDATES

Section Name	Update Description
“High-Performance, 16-bit Digital Signal Controllers”	Moved location of Note 1 (RPn pin) references (see “Pin Diagrams”).
Section 3.0 “Memory Organization”	<p>Updated CPU Core Register map SFR reset value for CORCON (see Table 3-1).</p> <p>Removed Interrupt Controller Register Map SFR IPC29 and updated reset values for IPC0, IPC1, IPC14, IPC16, IPC23, IPC24, IPC27, and IPC28 (see Table 3-5).</p> <p>Removed Interrupt Controller Register Map SFR IPC24 and IPC29 and updated reset values for IPC0, IPC1, IPC2, IPC14, IPC16, IPC23, IPC27, and IPC28 (see Table 3-6).</p> <p>Removed Interrupt Controller Register Map SFR IPC24 and updated reset values for IPC1, IPC2, IPC4, IPC14, IPC16, IPC23, IPC24, IPC27, and IPC28 (see Table 3-7).</p> <p>Updated Interrupt Controller Register Map SFR reset values for IPC1, IPC14, IPC16, IPC23, IPC24, IPC27, and IPC28 (see Table 3-8).</p> <p>Updated Interrupt Controller Register Map SFR reset values for IPC1, IPC14, IPC16, IPC23, IPC24, IPC25, IPC26, IPC27, IPC28, and IPC29 (see Table 3-9).</p> <p>Updated Interrupt Controller Register Map SFR reset values for IPC1, IPC4, IPC14, IPC16, IPC23, IPC24, IPC25, IPC26, IPC27, IPC28, and IPC29 (see Table 3-10).</p> <p>Added SFR definitions for RPOR16 and RPOR17 (see Table 3-34, Table 3-35, and Table 3-36).</p> <p>Updated bit definitions for PORTA, PORTB, and PORTC SFRs (ODCA, ODCB, and ODCC) (see Table 3-37, Table 3-38, Table 3-39, and Table 3-40).</p> <p>Updated bit definitions and reset value for System Control Register map SFR CLKDIV (see Table 3-41).</p> <p>Added device-specific information to title of PMD Register Map (see Table 3-47).</p> <p>Added device-specific PMD Register Maps (see Table 3-46, Table 3-45, and Table 3-43).</p>

dsPIC33FJ06GS101/X02 and dsPIC33FJ16GSX02/X04

TABLE A-1: MAJOR SECTION UPDATES (CONTINUED)

Section Name	Update Description
Section 7.0 “Oscillator Configuration”	<p>Removed the first sentence of the third clock source item (External Clock) in Section 7.1.1 “System Clock sources”</p> <p>Updated the default bit values for DOZE and FRCDIV in the Clock Divisor Register (see Register 7-2).</p>
Section 8.0 “Power-Saving Features”	<p>Added the following six registers:</p> <ul style="list-style-type: none"> • “PMD1: Peripheral Module Disable Control Register 1” • “PMD2: Peripheral Module Disable Control Register 2” • “PMD3: Peripheral Module Disable Control Register 3” • “PMD4: Peripheral Module Disable Control Register 4” • “PMD6: Peripheral Module Disable Control Register 6” • “PMD7: Peripheral Module Disable Control Register 7”
Section 9.0 “I/O Ports”	<p>Added paragraph and Table 9-1 to Section 9.1.1 “Open-Drain Configuration”, which provides details on I/O pins and their functionality.</p> <p>Removed 9.1.2 “5V Tolerance”.</p> <p>Updated MUX range and removed virtual pin details in Figure 9-2.</p> <p>Updated PWM Input Name descriptions in Table 9-1.</p> <p>Added Section 9.4.2.3 “Virtual Pins”.</p> <p>Updated bit values in all Peripheral Pin Select Input Registers (see Register 9-1 through Register 9-14).</p> <p>Updated bit name information for Peripheral Pin Select Output Registers RPOR16 and RPOR17 (see Register 9-30 and Register 9-31).</p> <p>Added the following two registers:</p> <ul style="list-style-type: none"> • “RPOR16: Peripheral Pin Select Output Register 16” • “RPOR17: Peripheral Pin Select Output Register 17” <p>Removed the following sections:</p> <ul style="list-style-type: none"> • 9.4.2 “Available Peripherals” • 9.4.3.2 “Virtual Input Pins” • 9.4.3.4 “Peripheral Mapping” • 9.4.5 “Considerations for Peripheral Pin Selection” (and all subsections)
Section 14.0 “High-Speed PWM”	<p>Added Note 1 (remappable pin reference) to Figure 14-1.</p> <p>Added Note 2 (Duty Cycle resolution) to PWM Master Duty Cycle Register (Register 14-5), PWM Generator Duty Cycle Register (Register 14-7), and PWM Secondary Duty Cycle Register (Register 14-8).</p> <p>Added Note 2 and Note 3 and updated bit information for CLSRC and FLTSRC in the PWM Fault Current-Limit Control Register (Register 14-15).</p>
Section 15.0 “Serial Peripheral Interface (SPI)”	<p>Removed the following sections, which are now available in the related section of the dsPIC33F/PIC24H Family Reference Manual:</p> <ul style="list-style-type: none"> • 15.1 “Interrupts” • 15.2 “Receive Operations” • 15.3 “Transmit Operations” • 15.4 “SPI Setup” (retained Figure 15-1: SPI Module Block Diagram)

dsPIC33FJ06GS101/X02 and dsPIC33FJ16GSX02/X04

TABLE A-1: MAJOR SECTION UPDATES (CONTINUED)

Section Name	Update Description
Section 16.0 “Inter-Integrated Circuit (I²C™)”	<p>Removed the following sections, which are now available in the related section of the dsPIC33F/PIC24H Family Reference Manual:</p> <ul style="list-style-type: none"> • 16.3 “I²C Interrupts” • 16.4 “Baud Rate Generator” (retained Figure 16-1: I²C Block Diagram) • 16.5 “I²C Module Addresses • 16.6 “Slave Address Masking” • 16.7 “IPMI Support” • 16.8 “General Call Address Support” • 16.9 “Automatic Clock Stretch” • 16.10 “Software Controlled Clock Stretching (STREN = 1)” • 16.11 “Slope Control” • 16.12 “Clock Arbitration” • 16.13 “Multi-Master Communication, Bus Collision, and Bus Arbitration”
Section 17.0 “Universal Asynchronous Receiver Transmitter (UART)”	<p>Removed the following sections, which are now available in the related section of the dsPIC33F/PIC24H Family Reference Manual:</p> <ul style="list-style-type: none"> • 17.1 “UART Baud Rate Generator” • 17.2 “Transmitting in 8-bit Data Mode • 17.3 “Transmitting in 9-bit Data Mode • 17.4 “Break and Sync Transmit Sequence” • 17.5 “Receiving in 8-bit or 9-bit Data Mode” • 17.6 “Flow Control Using \overline{UxCTS} and \overline{UxRTS} Pins” • 17.7 “Infrared Support” <p>Removed IrDA references and Note 1, and updated the bit and bit value descriptions for UTXINV (UxSTA<14>) in the UARTx Status and Control Register (see Register 17-2).</p>
Section 18.0 “High-Speed 10-bit Analog-to-Digital Converter (ADC)”	<p>Updated bit value information for Analog-to-Digital Control Register (see Register 18-1).</p> <p>Updated TRGSRC6 bit value for Timer1 period match in the Analog-to-Digital Convert Pair Control Register 3 (see Register 18-8).</p>

dsPIC33FJ06GS101/X02 and dsPIC33FJ16GSX02/X04

TABLE A-1: MAJOR SECTION UPDATES (CONTINUED)

Section Name	Update Description
<p>Section 23.0 “Electrical Characteristics”</p>	<p>Updated Typ values for Thermal Packaging Characteristics (Table 23-3).</p> <p>Removed Typ value for DC Temperature and Voltage Specifications Parameter DC12 (Table 23-4).</p> <p>Updated all Typ values and conditions for DC Characteristics: Operating Current (IDD), updated last sentence in Note 2 (Table 23-5).</p> <p>Updated all Typ values for DC Characteristics: Idle Current (IDLE) (see Table 23-6).</p> <p>Updated all Typ values for DC Characteristics: Power Down Current (IPD) (see Table 23-7).</p> <p>Updated all Typ values for DC Characteristics: Doze Current (IDOZE) (see Table 23-8).</p> <p>Added Note 4 (reference to new table containing digital-only and analog pin information, as well as Current Sink/Source capabilities) in the I/O Pin Input Specifications (Table 23-9).</p> <p>Updated Max value for BOR electrical characteristics Parameter BO10 (see Table 23-11).</p> <p>Swapped Min and Typ values for Program Memory Parameters D136 and D137 (Table 23-12).</p> <p>Updated Typ values for Internal RC Accuracy Parameter F20 and added Extended temperature range to table heading (see Table 23-19).</p> <p>Removed all values for Reset, Watchdog Timer, Oscillator Start-up Timer, and Power-up Timer Parameter SY20 and updated conditions, which now refers to Section 20.4 “Watchdog Timer (WDT)” and LPRC Parameter F21a (see Table 23-22).</p> <p>Added specifications to High-Speed PWM Module Timing Requirements for Tap Delay (Table 23-29).</p> <p>Updated Min and Max values for 10-bit High-Speed Analog-to-Digital Module Parameters AD01 and AD11 (see Table 23-36).</p> <p>Updated Max value and unit of measure for DAC AC Specification (see Table 23-40).</p>

dsPIC33FJ06GS101/X02 and dsPIC33FJ16GSX02/X04

Revision C and D (March 2009)

This revision includes minor typographical and formatting changes throughout the data sheet text.

Global changes include:

- Changed all instances of OSC1 to OSC1 and OSC0 to OSC2
- Changed all instances of PGCx/EMUCx and PGDx/EMUDx (where x = 1, 2, or 3) to PGECx and PGEDx
- Changed all instances of VDDCORE and VDDCORE/VCAP to VCAP/VDDCORE

Other major changes are referenced by their respective section in the following table.

TABLE A-2: MAJOR SECTION UPDATES

Section Name	Update Description
“High-Performance, 16-bit Digital Signal Controllers”	Added “Application Examples” to list of features Updated all pin diagrams to denote the pin voltage tolerance (see “Pin Diagrams”). Added Note 2 to the 28-Pin QFN-S and 44-Pin QFN pin diagrams, which references pin connections to VSS.
Section 1.0 “Device Overview”	Added ACMP1-ACMP4 pin names and Peripheral Pin Select capability column to Pinout I/O Descriptions (see Table 1-1).
Section 2.0 “Guidelines for Getting Started with 16-bit Digital Signal Controllers”	Added new section to the data sheet that provides guidelines on getting started with 16-bit Digital Signal Controllers.
Section 3.0 “CPU”	Updated CPU Core Block Diagram with a connection from the DSP Engine to the Y Data Bus (see Figure 3-1). Vertically extended the X and Y Data Bus lines in the DSP Engine Block Diagram (see Figure 3-3).
Section 4.0 “Memory Organization”	Updated Reset value for ADCON in Table 4-25. Removed reference to dsPIC33FJ06GS102 devices in the PMD Register Map and updated bit definitions for PMD1 and PMD6, and removed PMD7 (see Table 4-43). Added a new PMD Register Map, which references dsPIC33FJ06GS102 devices (see Table 4-44). Updated RAM stack address and SPLIM values in the third paragraph of Section 4.2.6 “Software Stack” Removed Section 4.2.7 “Data Ram Protection Feature” .
Section 5.0 “Flash Program Memory”	Updated Section 5.3 “Programming Operations” with programming time formula.

dsPIC33FJ06GS101/X02 and dsPIC33FJ16GSX02/X04

TABLE A-2: MAJOR SECTION UPDATES (CONTINUED)

Section Name	Update Description
Section 8.0 “Oscillator Configuration”	<p>Added Note 2 to the Oscillator System Diagram (see Figure 8-1).</p> <p>Added a paragraph regarding FRC accuracy at the end of Section 8.1.1 “System Clock Sources”.</p> <p>Added Note 1 and Note 2 to the OSCON register (see Register).</p> <p>Added Note 1 to the OSCTUN register (see Register 8-4).</p> <p>Added Note 3 to Section 8.4.2 “Oscillator Switching Sequence”.</p>
Section 10.0 “I/O Ports”	<p>Removed Table 9-1 and added reference to pin diagrams for I/O pin availability and functionality.</p> <p>Added paragraph on ADPCFG register default values to Section 10.3 “Configuring Analog Port Pins”.</p> <p>Added Note box regarding PPS functionality with input mapping to Section 10.6.2.1 “Input Mapping”.</p>
Section 15.0 “High-Speed PWM”	<p>Updated Note 2 in the PTCON register (see Register 15-1).</p> <p>Added Note 4 to the PWMCONx register (see Register 15-6).</p> <p>Updated Notes for the PHASEx and SPHASEx registers (see Register 15-9 and Register 15-10, respectively).</p>
Section 16.0 “Serial Peripheral Interface (SPI)”	<p>Added Note 2 and Note 3 to the SPIxCON1 register (see Register 16-2).</p>
Section 18.0 “Universal Asynchronous Receiver Transmitter (UART)”	<p>Updated the Notes in the UxMode register (see Register 18-1).</p> <p>Updated the UTXINV bit settings in the UxSTA register and added Note 1 (see Register 18-2).</p>
Section 19.0 “High-Speed 10-bit Analog-to-Digital Converter (ADC)”	<p>Updated the SLOWCLK and ADCS<2:0> bit settings and updated Note 1 in the ADCON register (see Register 19-1).</p> <p>Removed all notes in the ADPCFG register and replaced them with a single note (see Register 19-4).</p> <p>Updated the SWTRGx bit settings in the ADCPCx registers (see Register 19-5, Register 19-6, Register 19-7, and Register 19-8).</p>

dsPIC33FJ06GS101/X02 and dsPIC33FJ16GSX02/X04

TABLE A-2: MAJOR SECTION UPDATES (CONTINUED)

Section Name	Update Description
Section 24.0 “Electrical Characteristics”	<p>Updated Typical values for Thermal Packaging Characteristics (see Table 24-3).</p> <p>Updated Min and Max values for Parameter DC12 (RAM Data Retention Voltage) and added Note 4 (see Table 24-4).</p> <p>Updated Characteristics for I/O Pin Input Specifications (see Table 24-9).</p> <p>Added ISOURCE to I/O Pin Output Specifications (see Table 24-10).</p> <p>Updated Program Memory values for Parameters 136, 137, and 138 (renamed to 136a, 137a, and 138a), added Parameters 136b, 137b, and 138b, and added Note 2 (see Table 24-12).</p> <p>Added Parameter OS42 (GM) to the External Clock Timing Requirements (see Table 24-16).</p> <p>Updated Conditions for symbol TPDLY (Tap Delay) and added symbol ACLK (PWM Input Clock) to the High-Speed PWM Module Timing Requirements (see Table 24-29).</p> <p>Updated Parameters AD01 and AD02 in the 10-bit High-Speed Analog-to-Digital Module Specifications (see Table 24-36).</p> <p>Updated Parameters AD50b, AD55b, and AD56b, and removed Parameters AD57b and AD60b from the 10-bit High-Speed Analog-to-Digital Module Timing Requirements (see Table 24-37).</p>

dsPIC33FJ06GS101/X02 and dsPIC33FJ16GSX02/X04

Revision E (December 2009)

The revision includes the following global update:

- Added Note 2 to the shaded table that appears at the beginning of each chapter. This new note provides information regarding the availability of registers and their associated bits

This revision also includes minor typographical and formatting changes throughout the data sheet text.

All other major changes are referenced by their respective section in the following table.

TABLE A-3: MAJOR SECTION UPDATES

Section Name	Update Description
“16-bit Microcontrollers and Digital Signal Controllers (up to 16-Kbyte Flash and up to 2-Kbyte SRAM) with High-Speed PWM, ADC and Comparators”	Changed CN6 to CN5 on pin 16 of dsPIC33FJ16GS502 28-pin SPDIP, SOIC pin diagram.
Section 2.0 “Guidelines for Getting Started with 16-bit Digital Signal Controllers”	Removed the 10 Ohm resistor from Figure 2-1.
Section 4.0 “Memory Organization”	Renamed bit 13 of the REFOCON SFR in the System Control Register Map from ROSIDL to ROSSLP and changed the All Resets value from ‘0000’ to ‘2300’ for the ACLKCON SFR (see 4-41).
Section 8.0 “Oscillator Configuration”	Updated the default reset values from R/W-0 to R/W-1 for the SELACLK and APSTSCLR<2:0> bits in the ACLKCON register (see Register 8-5). Renamed the ROSIDL bit to ROSSLP in the REFOCON register (see Register 8-6).
Section 9.0 “Power-Saving Features”	Updated the last paragraph of Section 9.2.2 “Idle Mode” to clarify when instruction execution begins. Added Note 1 to the PMD1 register (see Register 9-1).
Section 10.0 “I/O Ports”	Changed the reference to digital-only pins to 5V tolerant pins in the second paragraph of Section 10.2 “Open-Drain Configuration” .
Section 15.0 “High-Speed PWM”	Updated the smallest pulse width value from 0x0008 to 0x0009 in Note 1 of the shaded note that follows the MDC register (see Register 15-5). Updated the smallest pulse width value from 0x0008 to 0x0009 and the maximum pulse width value from 0x0FFE to 0x0008 in Note 2 of the shaded note that follows the PDCx and SDCx registers (see Register 15-7 and Register 15-8). Added Note 2 and updated the FLTDAT<1:0> and CLDAT<1:0> bits, changing the word ‘data’ to ‘state’ in the IOCONx register (see Register 15-14).
Section 18.0 “Universal Asynchronous Receiver Transmitter (UART)”	Updated the two baud rate range features to: 10 Mbps to 38 bps at 40 MIPS.

dsPIC33FJ06GS101/X02 and dsPIC33FJ16GSX02/X04

TABLE A-3: MAJOR SECTION UPDATES (CONTINUED)

Section Name	Update Description
Section 19.0 “High-Speed 10-bit Analog-to-Digital Converter (ADC)”	<p>Updated Note 1 in the ADCPC0 register (see Register 19-5).</p> <p>Updated Note 3 in the ADCPC1 register (see Register 19-6).</p> <p>Updated Note 2 in the ADCPC2 and ADCPC3 registers (see Register 19-7 and Register 19-8).</p>
Section 21.0 “Special Features”	<p>Updated the second paragraph and removed the fourth paragraph in Section 21.1 “Configuration Bits”.</p> <p>Updated the Device Configuration Register Map (see Table 21-1).</p>
Section 24.0 “Electrical Characteristics”	<p>Updated the Absolute Maximum Ratings for high temperature and added Note 4.</p> <p>Updated Idle Current (IDLE) Typical values in Table 24-6.</p> <p>Updated the Typ and Max values for Parameter DI50 in the I/O Pin Input Specifications table (see Table 24-9).</p> <p>Updated the Typ and Max values for Parameters DO10 and DO27 and the Min and Typ values for Parameter DO20 in the I/O Pin Output Specifications (see Table 24-10).</p> <p>Added parameter numbers to the Auxiliary PLL Clock Timing Specifications (see Table 24-18).</p> <p>Added parameters numbers and updated the Internal RC Accuracy Min, Typ, and Max values (see Table 24-19 and Table 24-20).</p> <p>Added parameter numbers, Note 2, updated the Min and Typ parameter values for MP31 and MP32, and removed the conditions for MP10 and MP11 in the High-Speed PWM Module Timing Requirements (see Table 24-29).</p> <p>Updated the SPIx Module Slave Mode (CKE = 1) Timing Characteristics (see Table 24-14).</p> <p>Added Parameter IM51 to the I2Cx Bus Data Timing Requirements (Master Mode) (see Table 24-34).</p> <p>Updated the Max value for Parameter AD33 in the 10-bit High-Speed Analog-to-Digital Module Specifications (see Table 24-36).</p> <p>Updated the titles and added parameter numbers to the Comparator and DAC Module Specifications (see Table 24-38 and Table 24-39) and the DAC Output Buffer Specifications (see Table 24-40).</p>

dsPIC33FJ06GS101/X02 and dsPIC33FJ16GSX02/X04

Revision F (January 2012)

All occurrences of VDDCORE have been removed throughout the document.

This revision also includes minor typographical and formatting changes throughout the data sheet text.

All other major changes are referenced by their respective section in the following table.

TABLE A-4: MAJOR SECTION UPDATES

Section Name	Update Description
“16-Bit Digital Signal Controllers (up to 16-Kbyte Flash and up to 2-Kbyte SRAM) with High-Speed PWM, ADC and Comparators”	<p>Added the VTLA package to the dsPIC33FJ16GS404 and dsPIC33FJ16GS504 devices (see TABLE 1: “dsPIC33FJ06GS101/X02 and dsPIC33FJ16GSX02/X04 Controller Families”).</p> <p>Added the “Referenced Sources” section.</p> <p>The following updates were made to the “Pin Diagrams” section:</p> <ul style="list-style-type: none">• Added 5V tolerant pin shading to pins 24-26 in the 28-pin SPDIP, SOIC package for the dsPIC33FJ16GS402• Updated pin 31 of the 44-pin QFN package for the dsPIC33FJ16GS404• Added VTLA pin diagrams for the dsPIC33FJ16GS404 and dsPIC33FJ16GS504 devices
Section 1.0 “Device Overview”	<p>Removed the Precision Band Gap Reference from the device block diagram (see Figure 1-1).</p> <p>Updated the Pinout I/O Descriptions for AVDD, and AVSS (see Table 1-1).</p>
Section 2.0 “Guidelines for Getting Started with 16-bit Digital Signal Controllers”	<p>Updated the Minimum Recommended Connection (see Figure 2-1).</p>
Section 8.0 “Oscillator Configuration”	<p>Updated the Oscillator System Diagram (see Figure 8-1).</p> <p>Added auxiliary clock configuration restrictions in Section 8.2 “Auxiliary Clock Generation”.</p> <p>Updated or added notes regarding register reset on a POR (see Register 8-1 through Register 8-5).</p>
Section 19.0 “High-Speed 10-bit Analog-to-Digital Converter (ADC)”	<p>Added Note 2 to ADCON: Analog-to-Digital Control Register (see Register 19-1).</p> <p>Removed all notes from ADSTAT: Analog-to-Digital Status Register (see Register 19-2).</p>
Section 20.0 “High-Speed Analog Comparator”	<p>Updated the Comparator Module Block Diagram (see Figure 20-1).</p>
Section 21.0 “Special Features”	<p>Add a new paragraph at the beginning of Section 21.1 “Configuration Bits”.</p> <p>Added the RTSP Effect column to the dsPIC33F Configuration Bits Description table (see Table 21-2).</p> <p>Updated the Connections for the On-chip Voltage Regulator diagram (see Figure 21-1).</p> <p>Updated the first paragraph of Section 21.7 “In-Circuit Debugger”.</p>

dsPIC33FJ06GS101/X02 and dsPIC33FJ16GSX02/X04

TABLE A-4: MAJOR SECTION UPDATES (CONTINUED)

Section Name	Update Description
<p>Section 24.0 “Electrical Characteristics”</p>	<p>Updated the Absolute Maximum Ratings.</p> <p>Updated the Operating MIPS vs. Voltage (see Table 24-1).</p> <p>Updated Parameter DC10 and Note 4, and removed Parameter DC18 from the DC Temperature and Voltage Specifications (see Table 24-4).</p> <p>Updated Note 2 in the IDD Operating Current specification (see Table 24-5).</p> <p>Updated all Typical values and Note 2 in the IIDL Operating Current specification (see Table 24-6).</p> <p>Updated Typical values for Parameters DC60d, DC60a, DC60b, and DC60c, and Note 2 in the IPD Operating Current specification (see Table 24-7).</p> <p>Added all Typical values and Note 2 in the IDOZE Operating Current specification (see Table 24-8).</p> <p>Updated Parameters DI19 and DI50, added Parameters DI128, DI129, DI60a, DI60b, and DI60c, and removed Parameter DI57 in the I/O Pin Input Specifications (see Table 24-9).</p> <p>Revised all I/O Pinout Output Specifications (see Table 24-10).</p> <p>Added Notes 2 and 3 to the BOR Electrical Characteristics (see Table 24-11).</p> <p>Added Note 1 to Internal Voltage Regulator Specifications (see Table 24-13).</p> <p>Updated the External Clock Timing diagram (see Figure 24-2).</p> <p>Added Note 2 to the PLL Clock Timing Specifications (see Table 24-17).</p> <p>Removed Note 2 from the Internal FRC Accuracy (see Table 24-19).</p> <p>Updated Parameters DO31 and DO32 in the I/O Timing Requirements (see Table 24-21).</p> <p>Updated the External Clock Timing Requirements for Timer1, Timer2, and Timer3 (see Table 24-23, Table 24-24, and Table 24-25, respectively).</p> <p>Updated Parameters OC15 and OC20 in the Simple OC/PWM Mode Timing Requirements (see Table 24-28).</p> <p>Revised all SPIx Module Timing Characteristics diagrams and all Timing Requirements (see Figure 24-11 through Figure 24-18 and Table 24-30 through Table 24-37, respectively).</p> <p>Added Note 2 to the 10-bit High-Speed ADC Module Specifications (see Table 24-40).</p> <p>Added Note 2 to the 10-bit High-Speed ADC Module Timing Requirements (see Table 24-41).</p> <p>Added Note 2 to the Comparator Module Specifications (see Table 24-42).</p> <p>Added Parameter DA08 and Note 2 in the DAC Module Specifications (see Table 24-43).</p> <p>Updated Parameter DA16 and Note 2 in the DAC Output Buffer DC Specifications (see Table 24-44).</p>

dsPIC33FJ06GS101/X02 and dsPIC33FJ16GSX02/X04

TABLE A-4: MAJOR SECTION UPDATES (CONTINUED)

Section Name	Update Description
Section 26.0 “50 MIPS Electrical Characteristics”	Added new chapter in support of 50 MIPS devices.
Section 27.0 “DC and AC Device Characteristics Graphs”	Added new chapter.
Section 28.0 “Packaging Information”	Added 44-pin VTLA package marking information and diagrams (see Section 28.1 “Package Marking Information” and Section 28.2 “Package Details” , respectively).
“Product Identification System”	Added the TL package definition.

dsPIC33FJ06GS101/X02 and dsPIC33FJ16GSX02/X04

Revision G (May 2014)

The values for the TUN<5:0> bits in [Register 8-4](#) (OSCTUN) have changed.

The DC Characteristics Idle Current values in [Section 24.0 “Electrical Characteristics”](#) have been updated.

The timer specifications in [Section 26.0 “50 MIPS Electrical Characteristics”](#) have been removed.

All diagrams in [Section 28.0 “Packaging Information”](#) have been updated.

Minor text edits have been applied throughout the document.

dsPIC33FJ06GS101/X02 and dsPIC33FJ16GSX02/X04

NOTES:

dsPIC33FJ06GS101/X02 and dsPIC33FJ16GSX02/X04

INDEX

A

AC Characteristics	300, 338, 345
Internal FRC Accuracy	303
Internal LPRC Accuracy	303
Load Conditions	300, 338
ADC	
Control Registers	246
Functionality	239
Arithmetic Logic Unit (ALU)	38
Assembler	
MPASM Assembler	284
Auxiliary Clock Generation	138

B

Barrel Shifter	42
Bit-Reversed Addressing	76
Example	77
Implementation	76
Sequence Table (16-Entry)	77
Block Diagrams	
16-Bit Timer1 Module	183
Connections for On-Chip Voltage Regulator	270
DSP Engine	39
dsPIC33F06GS101 Devices with 1 SAR	240
dsPIC33F06GS102 Devices with 1 SAR	241
dsPIC33F06GS202 Devices with 1 SAR	242
dsPIC33F16GS402/404 Devices with 1 SAR	243
dsPIC33F16GS502 Devices with 2 SARs	244
dsPIC33F16GS504 Devices with 2 SARs	245
dsPIC33FJ06GS101/X02 and dsPIC33FJ16GSX02/X04	18
dsPIC33FJ06GS101/X02 and dsPIC33FJ16GSX02/X04 CPU Core	32
High-Speed Analog Comparator	263
I2CX Module	226
Input Capture x	191
Multiplexing of Remappable Output for RPN	159
Oscillator System	135
Output Compare x Module	193
Partitioned Output Pair, Complementary PWM Mode	200
PLL	137
Remappable MUX Input for U1RX	157
Reset System	89
Shared Port Structure	155
Simplified Conceptual High-Speed PWM	199
SPIx Module	219
Timer2/3 (32-Bit)	187
Type B Timer	185
Type C Timer	185
UART1	233
Watchdog Timer (WDT)	271
Brown-out Reset (BOR)	94, 267, 270

C

C Compilers	
MPLAB XC Compilers	284
Clock Switching	146
Enabling	146
Sequence	146

Code Examples

Erasing a Program Memory Page	87
Initiating a Programming Sequence	88
Loading Write Buffers	88
Port Write/Read	156
PWRSV Instruction Syntax	147
Code Protection	267, 273
CodeGuard Security	267
Configuration Bits	267
Description	268
Configuration Register Map	267
Configuring Analog Port Pins	156
CPU	
Control Registers	34
CPU Clocking System	136
PLL Configuration	137
Selection	136
Sources	136
Customer Change Notification Service	392
Customer Notification Service	392
Customer Support	392

D

DAC	264
Output Range	264
Data Accumulators and Adder/Subtractor	40
Data Space Write Saturation	42
Overflow and Saturation	40
Round Logic	41
Write Back	41
Data Address Space	45
Alignment	45
Memory Map for dsPIC33FJ06GS101/102 Devices with 256 Bytes of RAM	46
Memory Map for dsPIC33FJ06GS202 Device with 1-Kbyte RAM	47
Memory Map for dsPIC33FJ16GS402/404/502/504 Devices with 2-Kbyte RAM	48
Near Data Space	45
Software Stack	73
Width	45
Data Addressing	
Overview	31
DC and AC Characteristics	
Graphs and Tables	347
DC Characteristics	288, 342
Doze Current (IDOZE)	294, 344
High Temperature	334
I/O Pin Input Specifications	295
I/O Pin Output Specifications	297, 336
Idle Current (IDLE)	292, 343
Operating Current (IDD)	290, 342
Operating MIPS vs. Voltage	288, 334, 342
Power-Down Current (IPD)	293, 335
Program Memory	299, 337
Temperature and Voltage	334
Temperature and Voltage Specifications	289
Thermal Operating Conditions	334

dsPIC33FJ06GS101/X02 and dsPIC33FJ16GSX02/X04

Demo/Development Boards, Evaluation and Starter Kits	286	Instruction Addressing Modes	73
Development Support	283	File Register Instructions	73
Third-Party Tools	286	Fundamental Modes Supported	74
Doze Mode	148	MAC Instructions	74
DSP Engine.....	38	MCU Instructions	73
Multiplier.....	40	Move and Accumulator Instructions.....	74
E		Other Instructions	74
Electrical Characteristics	287	Instruction Set	
50 MIPS	341	Overview.....	278
AC	338	Summary	275
AC Characteristics and		Instruction-Based Power-Saving Modes.....	147
Timing Parameters.....	300, 345	Idle.....	148
BOR	298	Sleep	147
Equations		Interfacing Program and Data Memory Spaces.....	78
Device Operating Frequency	136	Internal RC Oscillator	
FOSC Calculation.....	137	Use with WDT.....	271
Maximum Row Write Time	84	Internet Address	392
Minimum Row Write Time	84	Interrupts	
Programming Time	84	Alternate Interrupt Vector Table (AIVT)	97
XT with PLL Mode Example.....	137	Control and Status Registers.....	100
Errata	14	IECx	100
External Reset (EXTR).....	95	IFSx	100
F		INTCON1	100
Fail-Safe Clock Monitor (FSCM)	146	INTCON2.....	100
Flash Program Memory.....	83	INTTREG.....	100
Control Registers	84	IPCx.....	100
Operations	84	Interrupt Vector Table (IVT).....	97
Programming Algorithm	87	Reset Sequence	97
RTSP Operation.....	84	Setup Procedures	134
Table Instructions.....	83	Initialization.....	134
Flexible Configuration	267	Interrupt Disable	134
G		Interrupt Service Routine.....	134
Guidelines for Getting Started with 16-Bit DSCs.....	21	Trap Service Routine.....	134
H		Interrupts Coincident with Power Save Instructions	148
High-Speed 10-Bit Analog-to-Digital		J	
Converter (ADC)	239	JTAG Boundary Scan Interface	267
High-Speed Analog Comparator.....	263	JTAG Interface.....	272
Digital Logic	264	M	
Input Range	264	Memory Organization	43
Interaction with I/O Buffers.....	264	Microchip Internet Web Site.....	392
High-Speed PWM	197	Modulo Addressing	75
Control Registers	200	Applicability.....	76
High-Temperature Electrical Characteristics.....	333	Operation Example	75
I		Start and End Address	75
I/O Ports	155	W Address Register Selection	75
Parallel I/O (PIO).....	155	MPLAB Assembler, Linker, Librarian.....	284
Write/Read Timing	156	MPLAB ICD 3 In-Circuit Debugger	285
i ² C		MPLAB PM3 Device Programmer	285
Control Registers	227	MPLAB REAL ICE In-Circuit Emulator System	285
Operating Modes	225	MPLAB X Integrated Development	
In-Circuit Debugger	272	Environment Software	283
In-Circuit Emulation.....	267	MPLAB X SIM Software Simulator	285
In-Circuit Serial Programming (ICSP)	267, 272	MPLIB Object Librarian.....	284
Input Capture	191	MPLINK Object Linker	284
Control Register	192	O	
Input Change Notification.....	156	Open-Drain Configuration.....	156
		Oscillator Configuration	135
		Control Registers.....	139
		Output Compare	193
		Modes	194
		Operation Diagram	194

dsPIC33FJ06GS101/X02 and dsPIC33FJ16GSX02/X04

P

Packaging	351
Details	353
Marking	351
Peripheral Module Disable (PMD)	148
Peripheral Pin Select (PPS)	157
PICkit 3 In-Circuit Debugger/Programmer	285
Pinout I/O Descriptions (table)	19
Power-on Reset (POR)	94
Power-Saving Features	147
Clock Frequency and Switching	147
Power-up Timer (PWRT)	94
PPS	
Control Registers	161
Selectable Input Sources	158
Selection Output Sources	159
Program Address Space	43
Construction	78
Data Access from Program Memory Using Program Space Visibility	81
Data Access from Program Memory Using Table Instructions	80
Data Access from, Address Generation	79
Memory Maps	43
Table Read Instructions	
TBLRDH	80
TBLRDL	80
Visibility Operation	81
Program Memory	
Interrupt Vector	44
Organization	44
Reset Vector	44

R

Reference Clock Generation	138
Register Maps	
Analog Comparator Control for dsPIC33FJ06GS202	67
Analog Comparator Control for dsPIC33FJ16GS503/504	67
Change Notification for dsPIC33FJ06GS101	51
Change Notification for dsPIC33FJ06GS102/202 and dsPIC33FJ16GS402/502	51
Change Notification for dsPIC33FJ16GS404/504	51
CPU Core	50
High-Speed 10-Bit ADC for dsPIC33FJ06GS101	63
High-Speed 10-Bit ADC for dsPIC33FJ06GS102	63
High-Speed 10-Bit ADC for dsPIC33FJ06GS202	64
High-Speed 10-Bit ADC for dsPIC33FJ16GS402/404	64
High-Speed 10-Bit ADC for dsPIC33FJ16GS502	65
High-Speed 10-Bit ADC for dsPIC33FJ16GS504	66
High-Speed PWM	59
High-Speed PWM Generator 1	60
High-Speed PWM Generator 2 for dsPIC33FJ06GS101/ 202 and dsPIC33FJ16GSX02/X04	60
High-Speed PWM Generator 3 for dsPIC33FJ16GSX02/X04	61
High-Speed PWM Generator 4 for dsPIC33FJ06GS101 and dsPIC33FJ16GS50X	61
I2C1	62
Input Capture for dsPIC33FJ06GS202	58
Input Capture for dsPIC33FJ16GSX02/X04	59
Interrupt Controller for dsPIC33FJ06GS101	52

Interrupt Controller for dsPIC33FJ06GS102	53
Interrupt Controller for dsPIC33FJ06GS202	54
Interrupt Controller for dsPIC33FJ16GS402/404	55
Interrupt Controller for dsPIC33FJ16GS502	56
Interrupt Controller for dsPIC33FJ16GS504	57
NVM	71
Output Compare for dsPIC33FJ06GS101/X02	59
Output Compare for dsPIC33FJ16GSX02 and dsPIC33FJ06GSX04	59
PMD for dsPIC33FJ06GS101	71
PMD for dsPIC33FJ06GS102	71
PMD for dsPIC33FJ06GS202	72
PMD for dsPIC33FJ16GS402/404	72
PMD for dsPIC33FJ16GS502/504	72
PORTA	70
PORTB for dsPIC33FJ06GS101	70
PORTB for dsPIC33FJ06GS102/202 and dsPIC33FJ16GS402/404/502/504	70
PORTC for dsPIC33FJ16GS404/504	70
PPS Input	68
PPS Output for dsPIC33FJ06GS101	68
PPS Output for dsPIC33FJ06GS102/202 and dsPIC33FJ16GS402/502	69
PPS Output for dsPIC33FJ16GS404/504	69
SPI1	62
System Control	71
Timers for dsPIC33FJ06GS101/X02	58
Timers for dsPIC33FJ16GSX02/X04	58
UART1	62

Registers

ACLKCON (Auxiliary Clock Divisor Control)	144
ADBASE (Analog-to-Digital Base)	250
ADCON (Analog-to-Digital Control)	247
ADCPC0 (Analog-to-Digital Convert Pair Control 0)	251
ADCPC1 (Analog-to-Digital Convert Pair Control 1)	254
ADCPC2 (Analog-to-Digital Convert Pair Control 2)	257
ADCPC3 (Analog-to-Digital Convert Pair Control 3)	260
ADPCFG (Analog-to-Digital Port Configuration)	250
ADSTAT (Analog-to-Digital Status)	249
ALTDTRx (PWMx Alternate Dead-Time)	210
CLKDIV (Clock Divisor)	141
CMPCONx (Comparator Control x)	265
CMPDACx (Comparator DAC x Control)	266
CORCON (Core Control)	36, 101
DTRx (PWMx Dead-Time)	210
FCLCONx (PWMx Fault Current-Limit Control)	214
I2CxCON (I2Cx Control)	228
I2CxMSK (I2Cx Slave Mode Address Mask)	232
I2CxSTAT (I2Cx Status)	230
ICxCON (Input Capture x Control)	192
IEC0 (Interrupt Enable Control 0)	112
IEC1 (Interrupt Enable Control 1)	114
IEC3 (Interrupt Enable Control 3)	115
IEC4 (Interrupt Enable Control 4)	115
IEC5 (Interrupt Enable Control 5)	116
IEC6 (Interrupt Enable Control 6)	117
IEC7 (Interrupt Enable Control 7)	118
IFS0 (Interrupt Flag Status 0)	105
IFS1 (Interrupt Flag Status 1)	107
IFS3 (Interrupt Flag Status 3)	108
IFS4 (Interrupt Flag Status 4)	108

dsPIC33FJ06GS101/X02 and dsPIC33FJ16GSX02/X04

IFS5 (Interrupt Flag Status 5)	109	RPOR1 (Peripheral Pin Select Output 1).....	175
IFS6 (Interrupt Flag Status 6)	110	RPOR10 (Peripheral Pin Select Output 10).....	179
IFS7 (Interrupt Flag Status 7)	111	RPOR11 (Peripheral Pin Select Output 11).....	180
INTCON1 (Interrupt Control 1)	102	RPOR12 (Peripheral Pin Select Output 12).....	180
INTTREG (Interrupt Control and Status).....	133	RPOR13 (Peripheral Pin Select Output 13).....	181
IOCONx (PWMx I/O Control)	212	RPOR14 (Peripheral Pin Select Output 14).....	181
IPC0 (Interrupt Priority Control 0)	119	RPOR16 (Peripheral Pin Select Output 16).....	182
IPC1 (Interrupt Priority Control 1)	120	RPOR17 (Peripheral Pin Select Output 17).....	182
IPC14 (Interrupt Priority Control 14)	125	RPOR2 (Peripheral Pin Select Output 2).....	175
IPC16 (Interrupt Priority Control 16)	125	RPOR3 (Peripheral Pin Select Output 3).....	176
IPC2 (Interrupt Priority Control 2)	121	RPOR4 (Peripheral Pin Select Output 4).....	176
IPC23 (Interrupt Priority Control 23)	126	RPOR5 (Peripheral Pin Select Output 5).....	177
IPC24 (Interrupt Priority Control 24)	127	RPOR6 (Peripheral Pin Select Output 6).....	177
IPC25 (Interrupt Priority Control 25)	128	RPOR7 (Peripheral Pin Select Output 7).....	178
IPC26 (Interrupt Priority Control 26)	129	RPOR8 (Peripheral Pin Select Output 8).....	178
IPC27 (Interrupt Priority Control 27)	130	RPOR9 (Peripheral Pin Select Output 9).....	179
IPC28 (Interrupt Priority Control 28)	131	SDCx (PWMx Secondary Duty Cycle).....	207
IPC29 (Interrupt Priority Control 29)	132	SEVTCMP (PWM Special Event Compare)	204
IPC3 (Interrupt Priority Control 3)	122	SPHASEx (PWMx Secondary Phase-Shift).....	209
IPC4 (Interrupt Priority Control 4)	123	SPIxCON1 (SPIx Control 1).....	221
IPC5 (Interrupt Priority Control 5)	124	SPIxCON2 (SPIx Control 2).....	223
IPC7 (Interrupt Priority Control 7)	124	SPIxSTAT (SPIx Status and Control)	220
LEBCONx (Leading-Edge Blanking Control)	217	SR (CPU STATUS).....	34, 101
MDC (PWM Master Duty Cycle)	204	STRIGx (PWMx Secondary Trigger Compare Value)	216
NVMCON (Flash Memory Control)	85	T1CON (Timer1 Control)	184
NVMKEY (Nonvolatile Memory Key)	86	TRGCONx (PWMx Trigger Control)	211
OCxCON (Output Compare x Control).....	195	TRIGx (PWMx Primary Trigger Compare Value)	216
OSCCON (Oscillator Control)	139	TxCON (Timerx Control, x = 2).....	188
OSCTUN (FRC Oscillator Tuning)	143	TyCON (Timery Control, y = 3).....	189
PDCx (PWMx Generator Duty Cycle)	207	UxMODE (UARTx Mode).....	234
PHASEx (PWMx Primary Phase-Shift)	208	UxSTA (UARTx Status and Control).....	236
PLLFB (PLL Feedback Divisor).....	142	Reset	89
PMD1 (Peripheral Module Disable Control 1).....	149	Configuration Mismatch	95
PMD2 (Peripheral Module Disable Control 2).....	150	Illegal Condition	95
PMD3 (Peripheral Module Disable Control 3).....	151	Illegal Opcode.....	89, 95
PMD4 (Peripheral Module Disable Control 4).....	151	Security	89, 96
PMD6 (Peripheral Module Disable Control 6).....	152	System.....	92
PMD7 (Peripheral Module Disable Control 7).....	153	Trap Conflict	95
PTCON (PWM Time Base Control)	201	Uninitialized W Register.....	89, 95, 96
PTCON2 (PWM Clock Divider Select)	203	Resets.....	89
PTPER (PWM Master Time Base).....	203	Resources Required for Digital Phase-Shift ZVT Converter	30
PWMCAPx (Primary PWMx Time Base Capture).....	218	Revision History	373
PWMCONx (PWMx Control)	205	S	
RCON (Reset Control)	90	Serial Peripheral Interface (SPI)	219
REFOCON (Reference Oscillator Control).....	145	Software RESET Instruction (SWR)	95
RPINR0 (Peripheral Pin Select Input 0).....	161	Software Stack Pointer, Frame Pointer CALL Stack Frame	73
RPINR1 (Peripheral Pin Select Input 1).....	162	Special Features of the CPU	267
RPINR11 (Peripheral Pin Select Input 11).....	165	Symbols Used in Opcode Descriptions	276
RPINR18 (Peripheral Pin Select Input 18).....	166	T	
RPINR20 (Peripheral Pin Select Input 20).....	167	Temperature and Voltage Specifications AC	300, 338
RPINR21 (Peripheral Pin Select Input 21).....	168	Timer1.....	183
RPINR29 (Peripheral Pin Select Input 29).....	169	Timer2/3.....	185
RPINR3 (Peripheral Pin Select Input 3).....	163	16-Bit Operation	186
RPINR30 (Peripheral Pin Select Input 30).....	170	32-Bit Operation	186
RPINR31 (Peripheral Pin Select Input 31).....	171		
RPINR32 (Peripheral Pin Select Input 32).....	172		
RPINR33 (Peripheral Pin Select Input 33).....	173		
RPINR34 (Peripheral Pin Select Input 34).....	174		
RPINR7 (Peripheral Pin Select Input 7).....	164		
RPOR0 (Peripheral Pin Select Output 0).....	174		

dsPIC33FJ06GS101/X02 and dsPIC33FJ16GSX02/X04

Timing Diagrams

Analog-to-Digital Conversion per Input	329
Brown-out Situations	94
External Clock	301
High-Speed PWMx	311
High-Speed PWMx Fault	311
I/O	304
I2Cx Bus Data (Master Mode)	324
I2Cx Bus Data (Slave Mode)	326
I2Cx Bus Start/Stop Bits (Master Mode)	324
I2Cx Bus Start/Stop Bits Slave Mode)	326
Input Capture x (ICx)	309
OCx/PWMx	310
Output Compare x (OCx)	309
Reset, Watchdog Timer, Oscillator Start-up Timer and Power-up Timer	305
SPIx Master Mode (Full-Duplex, CKE = 0, CKP = x, SMP = 1)	315
SPIx Master Mode (Full-Duplex, CKE = 1, CKP = x, SMP = 1)	314
SPIx Master Mode (Half-Duplex, Transmit Only, CKE = 0)	312
SPIx Master Mode (Half-Duplex, Transmit Only, CKE = 1)	312
SPIx Slave Mode (Full-Duplex, CKE = 0, CKP = 0, SMP = 0)	322
SPIx Slave Mode (Full-Duplex, CKE = 0, CKP = 1, SMP = 0)	320
SPIx Slave Mode (Full-Duplex, CKE = 1, CKP = 0, SMP = 0)	316
SPIx Slave Mode (Full-Duplex, CKE = 1, CKP = 1, SMP = 0)	318
System Reset	93
Timer1, 2, 3 External Clock	307

Timing Requirements

10-Bit, High-Speed ADC Requirements	329
External Clock	301, 345
I/O	304
Input Capture x	309
Simple OCx/PWMx Mode	345
SPIx Master Mode (CKE = 0)	339
SPIx Master Mode (Full-Duplex, CKE = 0, CKP = x, SMP = 1)	315
SPIx Master Mode (Full-Duplex, CKE = 1, CKP = x, SMP = 1)	314
SPIx Master Mode (Half-Duplex, Transmit Only)	313
SPIx Module Master Mode (CKE = 1)	339
SPIx Module Slave Mode (CKE = 0)	340
SPIx Module Slave Mode (CKE = 1)	340
SPIx Slave Mode (Full-Duplex, CKE = 0, CKP = 0, SMP = 0)	323
SPIx Slave Mode (Full-Duplex, CKE = 0, CKP = 1, SMP = 0)	321
SPIx Slave Mode (Full-Duplex, CKE = 1, CKP = 0, SMP = 0)	317
SPIx Slave Mode (Full-Duplex, CKE = 1, CKP = 1, SMP = 0)	319

Timing Specifications

10-Bit High-Speed ADC Module	328
Auxiliary PLL Clock	302
Comparator Module	330
DAC Module	330
DAC Output Buffer DC	331
High-Speed PWMx Requirements	311
I2Cx Bus Data Requirements (Master Mode)	325
I2Cx Bus Data Requirements (Slave Mode)	327
Output Compare x Requirements	309
PLL Clock	302, 338
Reset, Watchdog Timer, Oscillator Start-up Timer, Power-up Timer and Brown-out Reset Requirements	306
Simple OCx/PWMx Mode Requirements	310
Timer1 External Clock Requirements	307
Timer2 External Clock Requirements	308
Timer3 External Clock Requirements	308

U

Universal Asynchronous Receiver Transmitter (UART)	233
Using the RCON Status Bits	96

V

Voltage Regulator (On-Chip)	270
-----------------------------------	-----

W

Watchdog Timer (WDT)	267, 271
Programming Considerations	271
Watchdog Timer Time-out Reset (WDTO)	95
WWW Address	392
WWW, On-Line Support	14

dsPIC33FJ06GS101/X02 and dsPIC33FJ16GSX02/X04

NOTES:

THE MICROCHIP WEB SITE

Microchip provides online support via our WWW site at www.microchip.com. This web site is used as a means to make files and information easily available to customers. Accessible by using your favorite Internet browser, the web site contains the following information:

- **Product Support** – Data sheets and errata, application notes and sample programs, design resources, user's guides and hardware support documents, latest software releases and archived software
- **General Technical Support** – Frequently Asked Questions (FAQ), technical support requests, online discussion groups, Microchip consultant program member listing
- **Business of Microchip** – Product selector and ordering guides, latest Microchip press releases, listing of seminars and events, listings of Microchip sales offices, distributors and factory representatives

CUSTOMER CHANGE NOTIFICATION SERVICE

Microchip's customer notification service helps keep customers current on Microchip products. Subscribers will receive e-mail notification whenever there are changes, updates, revisions or errata related to a specified product family or development tool of interest.

To register, access the Microchip web site at www.microchip.com. Under "Support", click on "Customer Change Notification" and follow the registration instructions.

CUSTOMER SUPPORT

Users of Microchip products can receive assistance through several channels:

- Distributor or Representative
- Local Sales Office
- Field Application Engineer (FAE)
- Technical Support

Customers should contact their distributor, representative or Field Application Engineer (FAE) for support. Local sales offices are also available to help customers. A listing of sales offices and locations is included in the back of this document.

Technical support is available through the web site at: <http://microchip.com/support>

dsPIC33FJ06GS101/X02 and dsPIC33FJ16GSX02/X04

NOTES:

dsPIC33FJ06GS101/X02 and dsPIC33FJ16GSX02/X04

PRODUCT IDENTIFICATION SYSTEM

To order or obtain information, e.g., on pricing or delivery, refer to the factory or the listed sales office.

dsPIC 33 FJ 06 GS1 02 T - 50 E / SP - XXX	
Microchip Trademark	_____
Architecture	_____
Flash Memory Family	_____
Program Memory Size (Kbyte)	_____
Product Group	_____
Pin Count	_____
Tape and Reel Flag (if applicable)	_____
Speed (if applicable)	_____
Temperature Range	_____
Package	_____
Pattern	_____

Architecture:	33	=	16-bit Digital Signal Controller
Flash Memory Family:	FJ	=	Flash program memory, 3.3V
Product Group:	GS1	=	Switch Mode Power Supply (SMPS) family
	GS2	=	Switch Mode Power Supply (SMPS) family
	GS4	=	Switch Mode Power Supply (SMPS) family
	GS5	=	Switch Mode Power Supply (SMPS) family
Pin Count:	01	=	18-pin
	02	=	28-pin
	04	=	44-pin
Speed	50	=	50 MIPS
Temperature Range:	I	=	-40°C to+85°C (Industrial)
	E	=	-40°C to+125°C (Extended)
	H	=	-40°C to+150°C (High)
Package:	PT	=	Plastic Thin Quad Flatpack - 10x10x1 mm body (TQFP)
	ML	=	Plastic Quad Flat, No Lead Package - 8x8 mm body (QFN)
	MM	=	Plastic Quad Flat, No Lead Package - 6x6x0.9 mm body (QFN-S)
	SO	=	Plastic Small Outline - Wide - 7.50 mm body (SOIC)
	SP	=	Skinny Plastic Dual In-Line - 300 mil body (SPDIP)
	TL	=	Very Thin Leadless Array - 6x6 mm body (VTLA)

Examples:

- a) dsPIC33FJ06GS102-E/SP:
SMPS dsPIC33, 6-Kbyte program memory, 28-pin, Extended temperature, SPDIP package.

dsPIC33FJ06GS101/X02 and dsPIC33FJ16GSX02/X04

NOTES:

Note the following details of the code protection feature on Microchip devices:

- Microchip products meet the specification contained in their particular Microchip Data Sheet.
- Microchip believes that its family of products is one of the most secure families of its kind on the market today, when used in the intended manner and under normal conditions.
- There are dishonest and possibly illegal methods used to breach the code protection feature. All of these methods, to our knowledge, require using the Microchip products in a manner outside the operating specifications contained in Microchip's Data Sheets. Most likely, the person doing so is engaged in theft of intellectual property.
- Microchip is willing to work with the customer who is concerned about the integrity of their code.
- Neither Microchip nor any other semiconductor manufacturer can guarantee the security of their code. Code protection does not mean that we are guaranteeing the product as “unbreakable.”

Code protection is constantly evolving. We at Microchip are committed to continuously improving the code protection features of our products. Attempts to break Microchip's code protection feature may be a violation of the Digital Millennium Copyright Act. If such acts allow unauthorized access to your software or other copyrighted work, you may have a right to sue for relief under that Act.

Information contained in this publication regarding device applications and the like is provided only for your convenience and may be superseded by updates. It is your responsibility to ensure that your application meets with your specifications. MICROCHIP MAKES NO REPRESENTATIONS OR WARRANTIES OF ANY KIND WHETHER EXPRESS OR IMPLIED, WRITTEN OR ORAL, STATUTORY OR OTHERWISE, RELATED TO THE INFORMATION, INCLUDING BUT NOT LIMITED TO ITS CONDITION, QUALITY, PERFORMANCE, MERCHANTABILITY OR FITNESS FOR PURPOSE. Microchip disclaims all liability arising from this information and its use. Use of Microchip devices in life support and/or safety applications is entirely at the buyer's risk, and the buyer agrees to defend, indemnify and hold harmless Microchip from any and all damages, claims, suits, or expenses resulting from such use. No licenses are conveyed, implicitly or otherwise, under any Microchip intellectual property rights.

Trademarks

The Microchip name and logo, the Microchip logo, dsPIC, FlashFlex, KEELOQ, KEELOQ logo, MPLAB, PIC, PICmicro, PICSTART, PIC³² logo, rPIC, SST, SST Logo, SuperFlash and UNI/O are registered trademarks of Microchip Technology Incorporated in the U.S.A. and other countries.

FilterLab, Hampshire, HI-TECH C, Linear Active Thermistor, MTP, SEEVAL and The Embedded Control Solutions Company are registered trademarks of Microchip Technology Incorporated in the U.S.A.

Silicon Storage Technology is a registered trademark of Microchip Technology Inc. in other countries.

Analog-for-the-Digital Age, Application Maestro, BodyCom, chipKIT, chipKIT logo, CodeGuard, dsPICDEM, dsPICDEM.net, dsPICworks, dsSPEAK, ECAN, ECONOMONITOR, FanSense, HI-TIDE, In-Circuit Serial Programming, ICSP, Mindi, MiWi, MPASM, MPF, MPLAB Certified logo, MPLIB, MPLINK, mTouch, Omniclient Code Generation, PICC, PICC-18, PICDEM, PICDEM.net, PICkit, PICtail, REAL ICE, rLAB, Select Mode, SQI, Serial Quad I/O, Total Endurance, TSHARC, UniWinDriver, WiperLock, ZENA and Z-Scale are trademarks of Microchip Technology Incorporated in the U.S.A. and other countries.

SQTP is a service mark of Microchip Technology Incorporated in the U.S.A.

GestIC and ULPP are registered trademarks of Microchip Technology Germany II GmbH & Co. KG, a subsidiary of Microchip Technology Inc., in other countries.

All other trademarks mentioned herein are property of their respective companies.

© 2008-2014, Microchip Technology Incorporated, Printed in the U.S.A., All Rights Reserved.

 Printed on recycled paper.

ISBN: 978-1-63276-216-0

Microchip received ISO/TS-16949:2009 certification for its worldwide headquarters, design and wafer fabrication facilities in Chandler and Tempe, Arizona; Gresham, Oregon and design centers in California and India. The Company's quality system processes and procedures are for its PIC[®] MCUs and dsPIC[®] DSCs, KEELOQ[®] code hopping devices, Serial EEPROMs, microperipherals, nonvolatile memory and analog products. In addition, Microchip's quality system for the design and manufacture of development systems is ISO 9001:2000 certified.

**QUALITY MANAGEMENT SYSTEM
CERTIFIED BY DNV
= ISO/TS 16949 =**



MICROCHIP

Worldwide Sales and Service

AMERICAS

Corporate Office
2355 West Chandler Blvd.
Chandler, AZ 85224-6199
Tel: 480-792-7200
Fax: 480-792-7277
Technical Support:
<http://www.microchip.com/support>
Web Address:
www.microchip.com

Atlanta
Duluth, GA
Tel: 678-957-9614
Fax: 678-957-1455

Austin, TX
Tel: 512-257-3370

Boston
Westborough, MA
Tel: 774-760-0087
Fax: 774-760-0088

Chicago
Itasca, IL
Tel: 630-285-0071
Fax: 630-285-0075

Cleveland
Independence, OH
Tel: 216-447-0464
Fax: 216-447-0643

Dallas
Addison, TX
Tel: 972-818-7423
Fax: 972-818-2924

Detroit
Novi, MI
Tel: 248-848-4000

Houston, TX
Tel: 281-894-5983

Indianapolis
Noblesville, IN
Tel: 317-773-8323
Fax: 317-773-5453

Los Angeles
Mission Viejo, CA
Tel: 949-462-9523
Fax: 949-462-9608

New York, NY
Tel: 631-435-6000

San Jose, CA
Tel: 408-735-9110

Canada - Toronto
Tel: 905-673-0699
Fax: 905-673-6509

ASIA/PACIFIC

Asia Pacific Office
Suites 3707-14, 37th Floor
Tower 6, The Gateway
Harbour City, Kowloon
Hong Kong
Tel: 852-2943-5100
Fax: 852-2401-3431

Australia - Sydney
Tel: 61-2-9868-6733
Fax: 61-2-9868-6755

China - Beijing
Tel: 86-10-8569-7000
Fax: 86-10-8528-2104

China - Chengdu
Tel: 86-28-8665-5511
Fax: 86-28-8665-7889

China - Chongqing
Tel: 86-23-8980-9588
Fax: 86-23-8980-9500

China - Hangzhou
Tel: 86-571-8792-8115
Fax: 86-571-8792-8116

China - Hong Kong SAR
Tel: 852-2943-5100
Fax: 852-2401-3431

China - Nanjing
Tel: 86-25-8473-2460
Fax: 86-25-8473-2470

China - Qingdao
Tel: 86-532-8502-7355
Fax: 86-532-8502-7205

China - Shanghai
Tel: 86-21-5407-5533
Fax: 86-21-5407-5066

China - Shenyang
Tel: 86-24-2334-2829
Fax: 86-24-2334-2393

China - Shenzhen
Tel: 86-755-8864-2200
Fax: 86-755-8203-1760

China - Wuhan
Tel: 86-27-5980-5300
Fax: 86-27-5980-5118

China - Xian
Tel: 86-29-8833-7252
Fax: 86-29-8833-7256

China - Xiamen
Tel: 86-592-2388138
Fax: 86-592-2388130

China - Zhuhai
Tel: 86-756-3210040
Fax: 86-756-3210049

ASIA/PACIFIC

India - Bangalore
Tel: 91-80-3090-4444
Fax: 91-80-3090-4123

India - New Delhi
Tel: 91-11-4160-8631
Fax: 91-11-4160-8632

India - Pune
Tel: 91-20-3019-1500

Japan - Osaka
Tel: 81-6-6152-7160
Fax: 81-6-6152-9310

Japan - Tokyo
Tel: 81-3-6880-3770
Fax: 81-3-6880-3771

Korea - Daegu
Tel: 82-53-744-4301
Fax: 82-53-744-4302

Korea - Seoul
Tel: 82-2-554-7200
Fax: 82-2-558-5932 or
82-2-558-5934

Malaysia - Kuala Lumpur
Tel: 60-3-6201-9857
Fax: 60-3-6201-9859

Malaysia - Penang
Tel: 60-4-227-8870
Fax: 60-4-227-4068

Philippines - Manila
Tel: 63-2-634-9065
Fax: 63-2-634-9069

Singapore
Tel: 65-6334-8870
Fax: 65-6334-8850

Taiwan - Hsin Chu
Tel: 886-3-5778-366
Fax: 886-3-5770-955

Taiwan - Kaohsiung
Tel: 886-7-213-7830

Taiwan - Taipei
Tel: 886-2-2508-8600
Fax: 886-2-2508-0102

Thailand - Bangkok
Tel: 66-2-694-1351
Fax: 66-2-694-1350

EUROPE

Austria - Wels
Tel: 43-7242-2244-39
Fax: 43-7242-2244-393

Denmark - Copenhagen
Tel: 45-4450-2828
Fax: 45-4485-2829

France - Paris
Tel: 33-1-69-53-63-20
Fax: 33-1-69-30-90-79

Germany - Dusseldorf
Tel: 49-2129-3766400

Germany - Munich
Tel: 49-89-627-144-0
Fax: 49-89-627-144-44

Germany - Pforzheim
Tel: 49-7231-424750

Italy - Milan
Tel: 39-0331-742611
Fax: 39-0331-466781

Italy - Venice
Tel: 39-049-7625286

Netherlands - Drunen
Tel: 31-416-690399
Fax: 31-416-690340

Poland - Warsaw
Tel: 48-22-3325737

Spain - Madrid
Tel: 34-91-708-08-90
Fax: 34-91-708-08-91

Sweden - Stockholm
Tel: 46-8-5090-4654

UK - Wokingham
Tel: 44-118-921-5800
Fax: 44-118-921-5820

03/25/14

Mouser Electronics

Authorized Distributor

Click to View Pricing, Inventory, Delivery & Lifecycle Information:

Microchip:

[DSPIC33FJ06GS101-E/P](#) [DSPIC33FJ06GS202T-I/MM](#) [DSPIC33FJ06GS202-I/MM](#) [DSPIC33FJ06GS102-I/SP](#)
[DSPIC33FJ06GS202-I/SO](#) [DSPIC33FJ06GS202T-I/SO](#) [DSPIC33FJ06GS102-E/SP](#) [DSPIC33FJ06GS101T-I/SO](#)
[DSPIC33FJ06GS102T-I/SO](#) [DSPIC33FJ06GS102-E/SO](#) [DSPIC33FJ06GS102-I/SO](#) [DSPIC33FJ16GS404-I/PT](#)
[DSPIC33FJ06GS101-I/P](#) [DSPIC33FJ06GS202-E/SO](#) [DSPIC33FJ06GS202-E/SP](#) [DSPIC33FJ06GS202-E/MM](#)
[DSPIC33FJ06GS202-I/SP](#) [DSPIC33FJ06GS102T-I/MM](#) [DSPIC33FJ16GS402-I/SO](#) [DSPIC33FJ06GS102-E/MM](#)
[DSPIC33FJ06GS101-E/SO](#) [DSPIC33FJ06GS102-I/MM](#) [DSPIC33FJ06GS101-I/SO](#) [DSPIC33FJ16GS504-E/ML](#)
[DSPIC33FJ16GS504-I/PT](#) [DSPIC33FJ16GS502-E/MM](#) [DSPIC33FJ16GS504-E/PT](#) [DSPIC33FJ16GS402-E/SP](#)
[DSPIC33FJ16GS402-I/SP](#) [DSPIC33FJ16GS402-I/MM](#) [DSPIC33FJ16GS404-I/ML](#) [DSPIC33FJ16GS404T-I/ML](#)
[DSPIC33FJ16GS502-E/SP](#) [DSPIC33FJ16GS502T-I/SO](#) [DSPIC33FJ16GS402-E/SO](#) [DSPIC33FJ16GS502-E/SO](#)
[DSPIC33FJ16GS402-E/MM](#) [DSPIC33FJ16GS504-I/ML](#) [DSPIC33FJ16GS402T-I/SO](#) [DSPIC33FJ16GS502-I/SP](#)
[DSPIC33FJ16GS504T-I/ML](#) [DSPIC33FJ16GS502-I/MM](#) [DSPIC33FJ16GS404-E/ML](#) [DSPIC33FJ16GS404-E/PT](#)
[DSPIC33FJ16GS402T-I/MM](#) [DSPIC33FJ16GS502T-I/MM](#) [DSPIC33FJ16GS502-I/SO](#) [DSPIC33FJ16GS404T-I/PT](#)
[DSPIC33FJ16GS504T-I/PT](#) [DSPIC33FJ16GS404-E/TL](#) [DSPIC33FJ16GS404-I/TL](#) [DSPIC33FJ16GS504-E/TL](#)
[DSPIC33FJ16GS504-I/TL](#) [DSPIC33FJ16GS402-50I/MM](#) [DSPIC33FJ16GS402-50I/SO](#) [DSPIC33FJ16GS402-50I/SP](#)
[DSPIC33FJ16GS402-H/MM](#) [DSPIC33FJ16GS402-H/SO](#) [DSPIC33FJ16GS402-H/SP](#) [DSPIC33FJ16GS402T-50I/MM](#)
[DSPIC33FJ16GS402T-50I/SO](#) [DSPIC33FJ16GS404-50I/ML](#) [DSPIC33FJ16GS404-50I/TL](#) [DSPIC33FJ16GS404-H/ML](#)
[DSPIC33FJ16GS404-H/PT](#) [DSPIC33FJ16GS404-H/TL](#) [DSPIC33FJ16GS404T-50I/ML](#) [DSPIC33FJ16GS404T-50I/TL](#)
[DSPIC33FJ16GS502-50I/MM](#) [DSPIC33FJ16GS502-50I/SO](#) [DSPIC33FJ16GS502-50I/SP](#) [DSPIC33FJ16GS502-](#)
[H/MM](#) [DSPIC33FJ16GS502-H/SO](#) [DSPIC33FJ16GS502-H/SP](#) [DSPIC33FJ16GS502T-50I/MM](#)
[DSPIC33FJ16GS502T-50I/SO](#) [DSPIC33FJ16GS504-50I/ML](#) [DSPIC33FJ16GS504-50I/TL](#) [DSPIC33FJ16GS504-H/ML](#)
[DSPIC33FJ16GS504-H/PT](#) [DSPIC33FJ16GS504-H/TL](#) [DSPIC33FJ16GS504T-50I/ML](#) [DSPIC33FJ16GS504T-50I/TL](#)
[DSPIC33FJ16GS504T-E/TL](#) [DSPIC33FJ16GS504T-I/TL](#) [DSPIC33FJ16GS404T-E/TL](#) [DSPIC33FJ16GS404T-I/TL](#)
[DSPIC33FJ16GS404-50I/PT](#) [DSPIC33FJ16GS404T-50I/PT](#) [DSPIC33FJ16GS504-50I/PT](#) [DSPIC33FJ16GS504T-](#)
[50I/PT](#) [DSPIC33FJ16GS502T-E/MX](#) [DSPIC33FJ16GS502-E/MX](#)

Компания «Океан Электроники» предлагает заключение долгосрочных отношений при поставках импортных электронных компонентов на взаимовыгодных условиях!

Наши преимущества:

- Поставка оригинальных импортных электронных компонентов напрямую с производств Америки, Европы и Азии, а так же с крупнейших складов мира;
- Широкая линейка поставок активных и пассивных импортных электронных компонентов (более 30 млн. наименований);
- Поставка сложных, дефицитных, либо снятых с производства позиций;
- Оперативные сроки поставки под заказ (от 5 рабочих дней);
- Экспресс доставка в любую точку России;
- Помощь Конструкторского Отдела и консультации квалифицированных инженеров;
- Техническая поддержка проекта, помощь в подборе аналогов, поставка прототипов;
- Поставка электронных компонентов под контролем ВП;
- Система менеджмента качества сертифицирована по Международному стандарту ISO 9001;
- При необходимости вся продукция военного и аэрокосмического назначения проходит испытания и сертификацию в лаборатории (по согласованию с заказчиком);
- Поставка специализированных компонентов военного и аэрокосмического уровня качества (Xilinx, Altera, Analog Devices, Intersil, Interpoint, Microsemi, Actel, Aeroflex, Peregrine, VPT, Syfer, Eurofarad, Texas Instruments, MS Kennedy, Miteq, Cobham, E2V, MA-COM, Hittite, Mini-Circuits, General Dynamics и др.);

Компания «Океан Электроники» является официальным дистрибьютором и эксклюзивным представителем в России одного из крупнейших производителей разъемов военного и аэрокосмического назначения «JONHON», а так же официальным дистрибьютором и эксклюзивным представителем в России производителя высокотехнологичных и надежных решений для передачи СВЧ сигналов «FORSTAR».



JONHON

«JONHON» (основан в 1970 г.)

Разъемы специального, военного и аэрокосмического назначения:

(Применяются в военной, авиационной, аэрокосмической, морской, железнодорожной, горно- и нефтедобывающей отраслях промышленности)

«FORSTAR» (основан в 1998 г.)

ВЧ соединители, коаксиальные кабели, кабельные сборки и микроволновые компоненты:

(Применяются в телекоммуникациях гражданского и специального назначения, в средствах связи, РЛС, а так же военной, авиационной и аэрокосмической отраслях промышленности).



Телефон: 8 (812) 309-75-97 (многоканальный)

Факс: 8 (812) 320-03-32

Электронная почта: ocean@oceanchips.ru

Web: <http://oceanchips.ru/>

Адрес: 198099, г. Санкт-Петербург, ул. Калинина, д. 2, корп. 4, лит. А