

# Amphenol

## BACKSHELLS

For LJT, RNJ, RNJ LP, JT, TV-CTV, SC39 AND SJT CONNECTORS



For MIL-DTL-38999 series I,II,III and VG96912 connectors

[www.38999-solutions.com](http://www.38999-solutions.com) - [www.amphenol-socapex.com](http://www.amphenol-socapex.com)



# BACKSHELLS

## ■ ■ ■ TABLE OF CONTENTS

**GENERAL CHARACTERISTICS..... page 3**

**BACKSHELLS FOR SHIELDING..... page 4**  
 NSA and SA backshells ..... page 4  
 SQ backshells ..... page 6  
 NSB backshells ..... page 7

**BAND BACKSHELLS FOR SHIELDING..... page 8**  
 HE308-35 and TV35 backshells ..... page 8  
 SBC backshells..... page 10  
 Integrated backshells..... page 13

**STRAIN RELIEFS..... page 13**

**ADAPTERS FOR HEAT-SHRINK MOULDED PIECES ..... page 15**  
 NSD backshells..... page 15

**BACKSHELLS FOR POTTING..... page 15**  
 RPD backshells ..... page 15  
 RPC backshells ..... page 16

**HEAT-SHRINK MOULDED PIECES ..... page 17**

**HOW TO ORDER ..... page 18**

**TORQUE VALUE FOR REAR ACCESSORIES..... page 19**

**CROSS REFERENCES..... page 19**



## GENERAL CHARACTERISTICS

### Main features

- Shell material
  - Aluminium alloy
  - Marine bronze
  - For composite, please consult us
- Finish
  - Olive drab cadmium plating
  - Electroless nickel plating
  - For others, please consult us
- 9 shell sizes per model
- Straight or right angled versions
- Working temperature
  - From - 65°C to + 175°C with olive drab cadmium plating
  - From - 65°C to + 200°C with electroless nickel plating
- French standard qualification capability (UTE 93422)

For specific backshells for marine applications and 217 backshells, please consult us.

### Description

You will find hereafter Amphenol Socapex backshells for LJT (MIL-DTL-38999 series I / HE308), RNJ (HE308), RNJ LP, TV-CTV (MIL-DTL-38999 series III), SC39 and SJT (VG96912) connectors, as well as specific light weight backshells for JT (MIL-DTL-38999 series II) connectors. These rear accessories enhance the performance capabilities of the connectors for both general duty and severe environment applications.

Different technologies are used in order to ensure the following functions:

- EMI shielding
- cable retention
- sealing

This large choice of rear accessories provides you with the right solution for your connector/backshell interconnection.

## Applications

Military and aeronautic applications: battlefields, ground vehicles, aircrafts.

Advanced industrial applications with specific climatic, mechanical or electrical requirements.

# BACKSHELLS

## BACKSHELLS FOR SHIELDING

These backshells, providing an electrical continuity between cable and connector, ensure a high level of EMI/RFI protection. The sealing is ensured by straight or right angled heat shrink moulded piece at the rear of the backshell.

### NSA and SA backshells

**LJT NSA (HE308-13)** suitable for LJT (MIL-DTL-38999 series I / HE308), RNJ (HE308) and SJT (VG96912) connectors.

**JT SA** suitable for JT (MIL-DTL-38999 series II) connectors.

**TV NSA** suitable for TV-CTV (MIL-DTL-38999 series III), SC39 and RNJ LP connectors.

NSA and SA backshells ensure the shielding by clamping the braid with a screwing system. The free inner ring avoids twisting of the braid during screwing. For straight or right angled heat shrink moulded pieces, please refer to page 17-18.

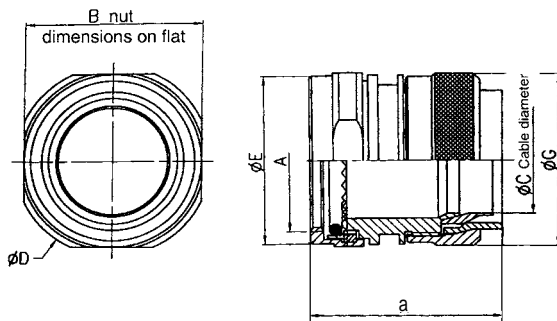

### LJT NSA & JT SA

a = 31.79 mm (1,252 in) max

Size		A Thread UNEF-2B	B max mm (in)	C max mm (in)	ø E max mm (in)	ø G max <sup>+0.2</sup> <sub>0.5</sub> mm (in)
LJT	JT/SJT					
09	08	.4375-28	16.70 (0.658)	6.90 (0.272)	15.20 (0.598)	16.40 (0.646)
11	10	.5625-24	20.70 (0.815)	9.60 (0.378)	18.40 (0.724)	19.53 (0.769)
13	12	.6875-24	22.70 (0.894)	12.70 (0.500)	21.60 (0.850)	22.60 (0.890)
15	14	.8125-20	25.70 (1.012)	14.80 (0.583)	24.80 (0.976)	25.80 (1.016)
17	16	.9375-20	28.70 (1.130)	17.90 (0.705)	28.00 (1.102)	28.80 (1.134)
19	18	1.0625-18	31.70 (1.248)	19.90 (0.784)	31.00 (1.221)	31.80 (1.252)
21	20	1.1875-18	35.70 (1.406)	23.10 (0.909)	34.20 (1.347)	33.87 (1.334)
23	22	1.3125-18	38.70 (1.524)	26.20 (1.032)	37.40 (1.472)	36.90 (1.453)
25	24	1.4375-18	41.70 (1.642)	28.80 (1.134)	40.60 (1.598)	41.52 (1.635)

## TV NSA

a = 35.60 mm (1.402 in) max

Size	A Thread Metric	B max mm (in)	C max mm (in)	Ø E max mm (in)	Ø G max <sup>+0.2</sup> <sub>0.5</sub> mm (in)
09	M12 x 1.0 – 6H	16.70 (0.658)	6.90 (0.272)	15.62 (0.615)	16.50 (0.650)
11	M15 x 1.0 – 6H	20.70 (0.815)	9.60 (0.378)	18.62 (0.733)	19.40 (0.764)
13	M18 x 1.0 – 6H	22.70 (0.894)	12.70 (0.500)	21.64 (0.852)	22.60 (0.890)
15	M22 x 1.0 – 6H	25.70 (1.012)	14.80 (0.583)	25.60 (1.008)	25.80 (1.016)
17	M25 x 1.0 – 6H	28.70 (1.130)	17.90 (0.705)	28.50 (1.122)	29.00 (1.142)
19	M28 x 1.0 – 6H	31.70 (1.248)	19.90 (0.784)	31.62 (1.245)	32.00 (1.260)
21	M31 x 1.0 – 6H	35.70 (1.406)	23.10 (0.909)	34.11 (1.343)	35.20 (1.386)
23	M34 x 1.0 – 6H	38.70 (1.524)	26.20 (1.032)	37.13 (1.462)	38.40 (1.512)
25	M37 x 1.0 – 6H	41.70 (1.642)	28.80 (1.134)	40.13 (1.580)	41.50 (1.634)

## ASSEMBLY INSTRUCTIONS FOR NSA and SA backsells

1. Prepare the cable for termination process and slide onto the cable the items in the order shown on figure 1.
2. Screw the backshell at the rear of the connector.
3. Fold back the braid on the outer jacket and fix it (figure 2)
4. Install the braid as shown on figures 3 and 4: Release the braid and cover the backshell (a) and the connector's shell. Slide the first ring (b) over the braid. Fold back the braid on the ring (b) and slide the second ring (c) over the braid and the first ring (b). Screw the last ring (d) at the rear of the backshell. If necessary, fix the extra braid on the outer jacket of the cable. If this installation (double folding of the braid) is not possible, refer to figure 5: Slide the first ring (b). Release the braid and cover the backshell (a) and the connector's shell. Cut the braid as shown. Slide the second ring (c) over the braid and the first ring (b). Screw the last ring at the rear of the backshell.
5. Install the heat-shrink moulded piece.

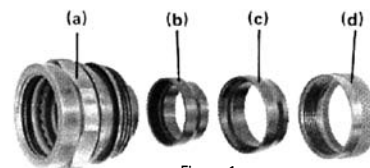

Figure 1



Figure 2

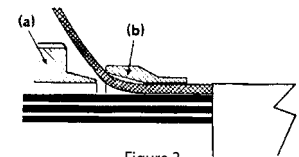

Figure 3

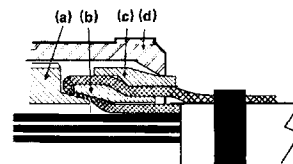

Figure 4

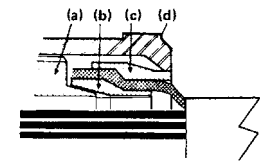

Figure 5

For ordering information, please refer to page 18

# BACKSHELLS

## BACKSHELLS FOR SHIELDING

### SQ backshells

LJT SQ suitable for SJT (VG96912) connectors.

SQ backshells ensure the shielding by clamping the braid with a screwing system. For straight or right angled heat shrink moulded pieces, please refer to page 17-18.

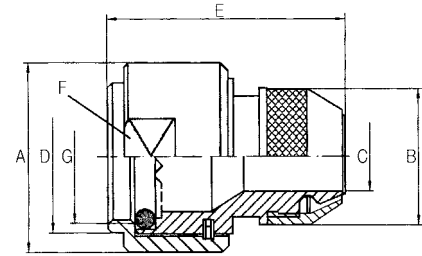

Size	$\varnothing A^{+0.2}_{-0.2}$ mm (in)	$\varnothing B^{+0.3}$ mm (in)	$\varnothing C^{+0.2}$ mm (in)	$\varnothing D \text{ max}$ mm (in)	E max mm (in)	F <sup>-0.2</sup> mm (in)	G Thread UNEF-2B
08	19.00 (0.748)	14.00 (0.551)	6.20 (0.244)	16.00 (0.630)	30.00 (1.181)	17.00 (0.670)	7/16-28
10	22.00 (0.867)	16.00 (0.630)	7.00 (0.276)	19.00 (0.748)	30.00 (1.181)	20.00 (0.787)	9/16-24
12	25.00 (0.984)	18.00 (0.709)	9.50 (0.374)	22.00 (0.867)	30.00 (1.181)	23.00 (0.906)	11/16-24
14	28.00 (1.102)	22.00 (0.867)	12.50 (0.492)	25.10 (0.988)	33.00 (1.300)	26.00 (1.024)	13/16-20
16	30.00 (1.181)	25.00 (0.984)	15.50 (0.610)	28.30 (1.114)	33.00 (1.300)	28.00 (1.102)	15/16-20
18	34.00 (1.339)	28.00 (1.102)	18.50 (0.728)	31.30 (1.232)	34.00 (1.339)	32.00 (1.260)	11/16-18
20	38.00 (1.496)	32.00 (1.260)	21.50 (0.846)	34.50 (1.358)	36.00 (1.417)	36.00 (1.417)	13/16-18
22	43.00 (1.693)	34.00 (1.339)	23.50 (0.925)	37.70 (1.484)	36.00 (1.417)	41.00 (1.614)	15/16-18
24	45.00 (1.772)	38.00 (1.496)	27.5 (1.083)	40.80 (1.606)	36.00 (1.417)	43.00 (1.693)	17/16-18

### ASSEMBLY INSTRUCTIONS FOR SQ backshells

1. Prepare the cable for termination process.
2. Screw the backshell at the rear of the connector.
3. Install the braid as shown on figure 1: Release the braid and cover the backshell conus. Maintain the braid on the conus with a small diameter wire in the groove. Fold back the braid on itself and cut it as shown. Screw the ring over the braid without twisting it.
4. Install the heat-shrink moulded piece.

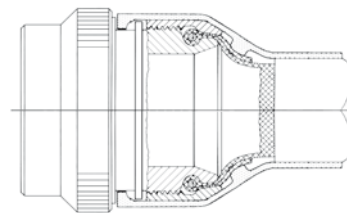

Figure 1

For ordering information, please refer to page 18

## BACKSHELLS FOR SHIELDING

### NSB backshells

LJT NSB suitable for LJT (MIL-DTL-38999 series I / HE308), RNJ (HE308) and SJT (VG96912) connectors.

NSB backshells ensure the shielding by a tinned rear part to allow soldering of the braid. For straight or right angled heat shrink moulded pieces, please refer to page 17-18.

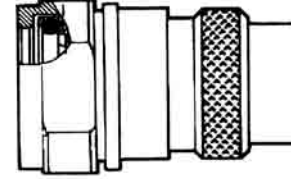

Size	Ø A mm (in)	Ø B ±0.2 mm (in)	Ø C max mm (in)	D* min mm (in)	E max mm (in)	F** max mm (in)
9	12.60 (0.496)	20.00 (0.787)	16.00 (0.630)	7.80 (0.307)	9.50 (0.374)	16.80 (0.661)
11	16.40 (0.646)	23.00 (0.906)	19.00 (0.748)	10.80 (0.425)	12.50 (0.492)	20.80 (0.819)
13	20.00 (0.787)	26.00 (1.024)	22.00 (0.866)	13.10 (0.516)	15.50 (0.610)	22.80 (0.898)
15	22.00 (0.866)	29.00 (1.142)	25.10 (0.988)	16.30 (0.642)	18.50 (0.728)	25.80 (1.016)
17	24.60 (0.969)	32.00 (1.260)	28.30 (1.114)	19.00 (0.748)	21.50 (0.847)	28.80 (1.134)
19	27.50 (1.083)	35.00 (1.378)	31.30 (1.232)	21.70 (0.854)	24.00 (0.945)	31.80 (1.252)
21	31.90 (1.256)	39.00 (1.536)	34.50 (1.358)	24.90 (0.980)	27.00 (1.063)	35.80 (1.409)
23	35.00 (1.378)	42.00 (1.654)	37.70 (1.484)	28.10 (1.106)	30.50 (1.201)	38.80 (1.528)
25	38.80 (1.528)	45.00 (1.772)	40.80 (1.606)	31.20 (1.228)	33.50 (1.319)	41.80 (1.646)

\* max permissible cable outside diameter  
\*\* dimension over the flats (4 flats)

### NSB backshells

1. Prepare the cable for termination process.
2. Screw the backshell at the rear of the connector.
3. If possible, protect the conductors with an insulating tube or tape (e) inserted between them and the backshell.
4. Install the braid as shown of figure 1.
5. Install the heat-shrink moulded piece.



Figure 2

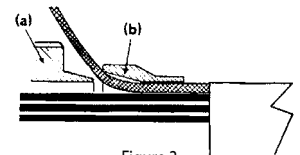

Figure 3

For ordering information, please refer to page 18

# BACKSHELLS

## BAND BACKSHELLS FOR SHIELDING

These band backsells provide a full 360° shield termination. They are available with different cabling chamber lengths and exit diameters. The use of replaceable bands facilitates future maintenance or reparability. The sealing is ensured by straight or right angled heat shrink moulded piece at the rear of the backshell.

### HE308-35 and TV35 backsells

**HE308-35** suitable for LJT (MIL-DTL-38999 series I / HE308), RNJ (HE308) and SJT (VG96912) connectors.

**TV35** suitable for TV-CTV (MIL-DTL-38999 series III), SC39 and RNJ LP connectors.

**TVB35** suitable for TV bronze connectors.

These straight band backsells provide a full 360° shield termination with a quick, easy and cost effective cabling process. For straight or right angled heat shrink moulded pieces, please refer to page 17-18.

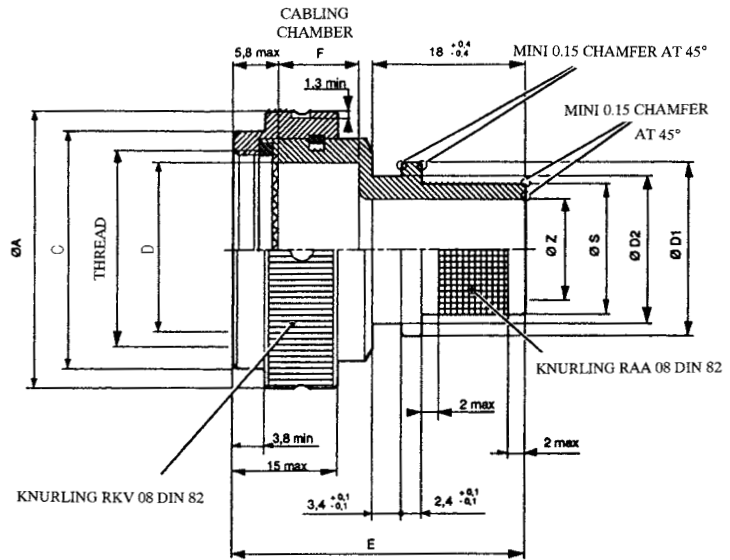

Size	HE308-35 only				TV35 and TVB35 only			
	Ø A max mm (in)	B Thread UNEF-2B	Ø C mm (in)	Ø D mm (in)	Ø A max mm (in)	B Thread Metric	Ø C mm (in)	Ø D mm (in)
09	21.40 (0.843)	0.4375-28	15.20 (0.598)	7.80 (0.307)	24.30 (0.957)	M12 x 1.0-6H	18.00 (0.709)	7.80 (0.307)
11	24.30 (0.957)	0.5625-24	18.40 (0.724)	10.80 (0.425)	27.40 (1.079)	M15 x 1.0-6H	21.00 (0.827)	10.99 (0.433)
13	27.40 (1.079)	0.6875-24	21.60 (0.850)	13.10 (0.516)	31.80 (1.252)	M18 x 1.0-6H	25.00 (0.984)	13.80 (0.543)
15	31.80 (1.252)	0.8125-20	24.80 (0.976)	16.30 (0.642)	35.00 (1.378)	M22 x 1.0-6H	28.00 (1.102)	16.30 (0.642)
17	35.00 (1.378)	0.9375-20	28.00 (1.102)	19.50 (0.768)	38.10 (1.500)	M25 x 1.0-6H	30.80 (1.213)	20.10 (0.791)
19	38.10 (1.500)	1.0625-18	31.00 (1.220)	21.70 (0.854)	41.20 (1.622)	M28 x 1.0-6H	34.10 (1.343)	22.93 (0.903)
21	41.20 (1.622)	1.1875-18	34.20 (1.347)	24.90 (0.980)	44.30 (1.744)	M31 x 1.0-6H	36.90 (1.453)	26.00 (1.024)
23	44.30 (1.744)	1.3125-18	37.40 (1.472)	28.10 (1.106)	47.20 (1.858)	M34 x 1.0-6H	39.80 (1.567)	29.28 (1.153)
25	47.20 (1.858)	1.4375-18	40.60 (1.599)	31.20 (1.228)	50.00 (1.969)	M37 x 1.0-6H	43.00 (1.693)	32.45 (1.278)





## ■ ■ ■ BAND BACKSHELLS FOR SHIELDING

Size	E max mm (in)	Cabling chamber length F <sup>±0.1</sup> mm (in)	Z rear side diameter		Ø S min/max mm (in)	Ø D1 <sup>±0.1</sup> mm (in)	Ø D2 <sup>±0.1</sup> mm (in)
			Coding 1/32 of Inch	Dimension min mm (in)			
09	36 (1.417)	10 (0.394)	08	6.30 (0.248)	9.40/9.50 (0.370/0.374)	14.00 (0.551)	11.40 (0.449)
11	36 (1.417)	10 (0.394)	12	9.40 (0.370)	12.60/12.70 (0.496/0.500)	17.10 (0.673)	14.50 (0.571)
13	36 (1.417) 36 or 56 (1.417 or 2.204)	10 (0.394) 10 or 30 (0.394 or 1.181)	12 16	9.40 (0.370) 12.60 (0.496)	12.60/12.70 (0.496/0.500) 15.70/15.90 (0.618/0.626)	17.10 (0.673) 20.30 (0.799)	14.50 (0.571) 17.70 (0.697)
15	36 (1.417) 36 (1.417) 36 or 56 (1.417 or 2.204)	10 (0.394) 10 (0.394) 10 or 30 (0.394 or 1.181)	10 14 20	7.80 (0.307) 11.00 (0.433) 15.80 (0.622)	11.1/11.2 (0.437/0.440) 14.10/14.30 (0.555/0.563) 18.90/19.10 (0.744/0.752)	15.5 (0.610) 18.70 (0.736) 23.50 (0.925)	12.9 (0.508) 16.10 (0.634) 20.90 (0.823)
17	36 (1.417) 51 (2.008) 36 or 56 (1.417 or 2.204)	10 (0.394) 25 (0.984) 10 or 30 (0.394 or 1.181)	16 12 24	12.60 (0.496) 9.40 (0.370) 19.00 (0.748)	15.70/15.90 (0.618/0.626) 12.60/12.70 (0.496/0.500) 22.00/22.20 (0.866/0.874)	20.30 (0.799) 17.10 (0.673) 26.70 (1.051)	17.70 (0.697) 14.50 (0.571) 23.10 (0.909)
19	36 (1.417) 36 or 56 (1.417 or 2.204)	10 (0.394) 10 or 30 (0.394 or 1.181)	16 24	12.60 (0.496) 19.00 (0.748)	15.70/15.90 (0.618/0.626) 22.00/22.20 (0.866/0.874)	20.30 (0.800) 26.70 (1.051)	17.70 (0.697) 23.10 (0.909)
21	36 (1.417) 46 (1.811) 36 or 56 (1.417 or 2.204)	10 (0.394) 20 (0.787) 10 or 30 (0.394 or 1.181)	20 14 28	15.80 (0.622) 11.00 (0.433) 22.10 (0.870)	18.90/19.10 (0.744/0.752) 14.10/14.30 (0.555/0.563) 25.20/25.40 (0.992/1)	23.50 (0.925) 18.70 (0.736) 29.80 (1.173)	20.90 (0.823) 16.10 (0.634) 26.20 (1.032)
23	36 (1.417) 36 or 56 (1.417 or 2.204)	10 (0.394) 10 or 30 (0.394 or 1.181)	24 32	19.00 (0.748) 25.30 (0.996)	22.00/22.20 (0.866/0.874) 28.40/28.60 (1.118/1.126)	26.70 (1.051) 33.00 (1.299)	23.10 (0.909) 29.40 (1.158)
25	36 (1.417) 36 or 56 (1.417 or 2.204)	10 (0.394) 10 or 30 (0.394 or 1.181)	28 36	22.10 (0.870) 28.60 (1.126)	25.20/25.40 (0.992/1) 31.50/31.80 (1.240/1.252)	29.80 (1.173) 36.20 (1.425)	26.20 (1.032) 32.60 (1.284)

# BACKSHELLS

## BAND BACKSHELLS FOR SHIELDING

### SBC backshells

**LJT SBC** suitable for LJT (MIL-DTL-38999 series I / HE308), RNJ (HE308) and SJT (VG96912) connectors.

**TV SBC** suitable for TV-CTV (MIL-DTL-38999 series III), SC39 and RNJ LP connectors.

These right angled band backshells provide a full 360° shield termination with a quick, easy and cost effective cabling process. For straight heat shrink moulded pieces, please refer to page 17-18.

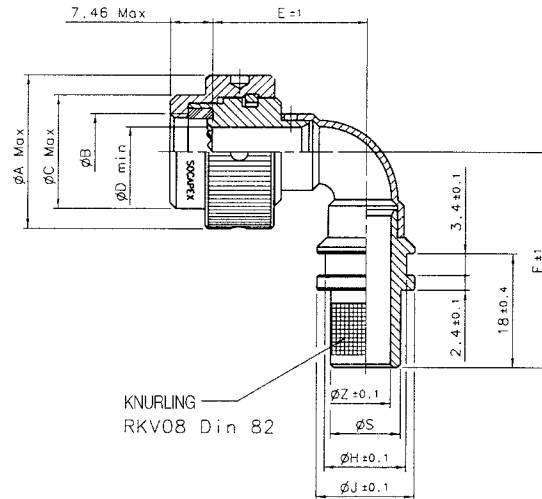

Size	LJT SBC only				TV SBC only			
	Ø A max mm (in)	B Thread UNEF-2B	Ø C mm (in)	Ø D mm (in)	Ø A max mm (in)	B Thread Metric	Ø C mm (in)	Ø D mm (in)
09	21.40 (0.843)	0.4375-28	15.20 (0.598)	7.80 (0.307)	24.30 (0.957)	M12 x 1.0-6H	18.00 (0.709)	7.80 (0.307)
11	24.30 (0.957)	0.5625-24	18.40 (0.724)	10.80 (0.425)	27.40 (1.079)	M15 x 1.0-6H	21.00 (0.827)	10.99 (0.433)
13	27.40 (1.079)	0.6875-24	21.60 (0.850)	13.10 (0.516)	31.80 (1.252)	M18 x 1.0-6H	25.00 (0.984)	13.80 (0.543)
15	31.80 (1.252)	0.8125-20	24.80 (0.976)	16.30 (0.642)	35.00 (1.378)	M22 x 1.0-6H	28.00 (1.102)	16.30 (0.642)
17	35.00 (1.378)	0.9375-20	28.00 (1.102)	19.50 (0.768)	38.10 (1.500)	M25 x 1.0-6H	30.80 (1.213)	20.10 (0.791)
19	38.10 (1.500)	1.0625-18	31.00 (1.220)	21.70 (0.854)	41.20 (1.622)	M28 x 1.0-6H	34.10 (1.343)	22.93 (0.903)
21	41.20 (1.622)	1.1875-18	34.20 (1.347)	24.90 (0.980)	44.30 (1.744)	M31 x 1.0-6H	36.90 (1.453)	26.00 (1.024)
23	44.30 (1.744)	1.3125-18	37.40 (1.472)	28.10 (1.106)	47.20 (1.858)	M34 x 1.0-6H	39.80 (1.567)	29.28 (1.153)
25	47.20 (1.858)	1.4375-18	40.60 (1.599)	31.20 (1.228)	50.00 (1.969)	M37 x 1.0-6H	43.00 (1.693)	32.45 (1.278)

Size	E mm (in)	Z rear side diameter		F mm (in)	Ø S mm (in)	Ø H mm (in)	Ø J mm (in)
		Coding 1/32 of Inch	Dimension mm (in)				
09	24.50 (0.965)	10	7.90 (0.311)	34.00 (1.339)	11.10 (0.437)	12.90 (0.508)	15.50 (0.610)
11	28.00 (1.102)	14	11.10 (0.437)	36.50 (1.437)	14.10 (0.555)	16.10 (0.634)	18.10 (0.713)
13	28.00 (1.102)	16	12.60 (0.496)	37.00 (1.457)	15.70 (0.618)	17.70 (0.697)	20.30 (0.799)
15	29.50 (1.161)	20	15.80 (0.622)	39.00 (1.535)	18.90 (0.744)	20.90 (0.823)	23.50 (0.925)
17	31.50 (1.240)	24	19.00 (0.748)	41.00 (1.614)	22.00 (0.866)	23.10 (0.909)	26.70 (1.051)
19	33.00 (1.299)	24	19.00 (0.748)	42.50 (1.673)	22.00 (0.866)	23.10 (0.909)	26.70 (1.051)
21	35.50 (1.398)	28	22.10 (0.870)	45.00 (1.772)	25.20 (0.992)	26.20 (1.032)	29.80 (1.173)
23	44.50 (1.752)	32	25.30 (0.996)	54.00 (2.126)	28.40 (1.118)	29.40 (1.158)	33.00 (1.299)
25	50.50 (1.988)	36	28.60 (1.126)	58.50 (2.303)	31.50 (1.240)	32.60 (1.284)	36.20 (1.425)

## ■ ■ ■ BAND BACKSHELLS FOR SHIELDING

### ASSEMBLY INSTRUCTIONS FOR HE308-35, TV35 and SBC backshells

1. Prepare the cable for termination process (figure 1).
2. Screw the backshell at the rear of the connector.
3. Push the braid over the backshell to the incline point. Milk the braid as required to remove the slack and insure a snug fit around the shield termination area (figure 2).
4. Prepare the band: Roll the band through the buckle slot twice (the band must be double-coiled). Pull on the band until the mark is within approximately 6.4 mm (.250 in) of the buckle slot (figure 3). The band may be tightened further if desired.
5. Squeeze the gripper release lever of the banding tool and insert the band into the front end opening of the tool as shown on figure 4 (the circular portion of looped band must always face downward).
6. Aligning the band and the tool with the shield termination area, squeeze the black pull-up handle repeatedly using short strokes until it locks against the tool body (this indicates the band is compressed to the tool precalibrated tension).
7. Complete the clamping process by squeezing the grey cut-off handle.
8. Remove the excess band from the tool.
9. Inspect shield termination (figure 5). If the alignment of the band and the shield is unsatisfactory, tension on the band can be relaxed by pushing on the slotted release lever on the top of the tool. Make adjustments as necessary and squeeze again the black pull-up handle.

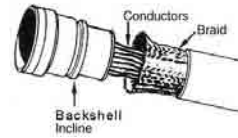

Figure 1

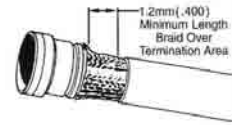

Figure 2

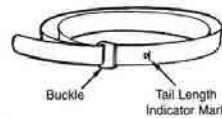

Figure 3

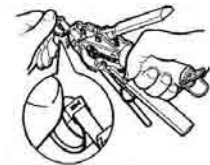

Figure 4

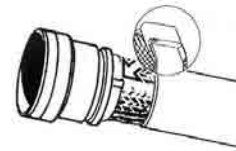

Figure 5

### HOW TO ORDER

#### Amphenol designation – Backshells for TV-CTV (MIL-DTL-38999 series III), SC39 and RNJ LP connectors

Series	TV	35	11	10	08	014
<b>Type of backshell</b>						
<b>35:</b> aluminium straight band backshell accepting heat shrink moulded piece						
<b>B35:</b> bronze straight band backshell accepting heat shrink moulded piece						
<b>SBC:</b> aluminium right angled band backshell accepting heat shrink moulded piece						
<b>Size of backshell</b> 09-11-13-15-17-19-21-23-25 (same as connector size)						
<b>Cabling chamber length</b> 10-20-25-30						
<i>For straight versions only - Refer to page 9 – Dimension F (mm)</i>						
<b>Rear side diameter</b>						
<i>Refer to page 9 – Dimension Z (1/32 of inch)</i>						
<b>Finish</b>						
<b>014:</b> olive-drab cadmium plating						
<b>023:</b> electroless nickel plating						
<b>Blank:</b> for bronze version						

# BACKSHELLS

## ■ ■ ■ BAND BACKSHELLS FOR SHIELDING

### HE 308 military designation – Backshells for HE 308 (LJT / MIL-DTL-38999 series I / RNJ) connectors

Series	HE308	-35	-11	-10	-08	-7	M
<b>Type of backshell</b>	35: band backshell accepting heat shrink moulded piece						
<b>Size of backshell</b>	09-11-13-15-17-19-21-23-25 (same as connector size)						
<b>Cabling chamber length</b>	10-20-25-30						
<i>Refer to page 9 – Dimension F (mm)</i>							
<b>Rear side diameter</b>	Refer to page 9 – Dimension Z (1/32 of inch)						
<b>Finish</b>	7: olive-drab cadmium plating 6: electroless nickel plating						
<b>Military standard</b>							

Note: Dashes are required in the P/N

### Amphenol designation - Backshells for LJT (MIL-DTL-38999 series I / HE308), RNJ (HE308) and SJT (VG96912) connectors

Series	LJT	SBC	11	08	014
<b>Type of backshell</b>	SBC: aluminium right angled band backshell accepting heat shrink moulded piece				
<b>Size of backshell</b>	09-11-13-15-17-19-21-23-25 (same as connector size)				
<b>Rear side diameter</b>	Refer to page 10 – Dimension Z (1/32 of inch)				
<b>Finish</b>	014: olive-drab cadmium plating 023: electroless nickel plating				

## TOOLING & ACCESSORIES

### Coupling tool

Coupling wrench for HE308-35 and TV(B) 35 backshells: **116.50** (Facom p/n)

### Clamping bands

Standard band: **072952**

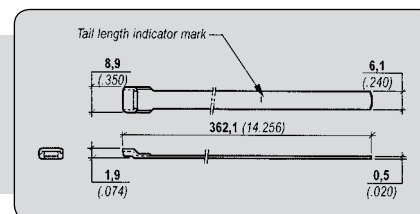

Micro band (precoiled): **895693**

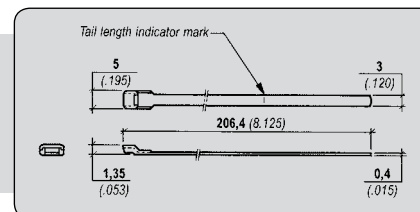

### Hand banding tools

Banding tool for standard band: **809952**

Banding tool for micro band: **809953**

Caution: Tools and bands should never be lubricated

## Integrated backshells

Suitable for LJT (MIL-DTL-38999 series I / HE308), JT (MIL-DTL-38999 series II), TV (MIL-DTL-38999 series III), SC39 and SJT (VG96912) connectors.

Available on plugs and receptacles, these 2 in 1 connectors/band backshells provide a high EMI protection with a quick, easy and cost effective cabling process. They are low profile, with enhance sealing level and allow the use of macro and micro bands, as well as straight or right angled heat shrink moulded pieces. The design of the shells make them compatible with over moulding process.

Do not hesitate to consult us.

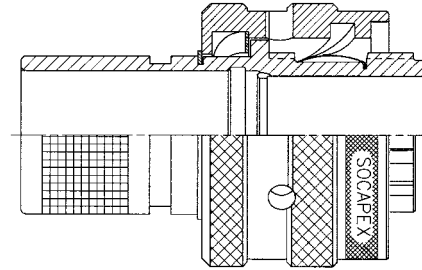

## STRAIN RELIEFS

These backshells ensure a mechanical retention of the cable.

### SRD backshells

JT SRD suitable for JT (MIL-DTL-38999 series II) connectors.

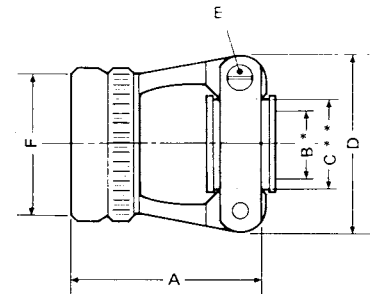

### JT SRD

Size	A Thread UNEF-2B	$\varnothing B^{+0.25}_{-0.64}$ mm (in)	$\varnothing C^{+0.3}$ mm (in)	$\varnothing D^{+0.3}$ mm (in)	E max mm (in)
08	.4375-28	3.18 (0.125)	6.35 (0.250)	19.05 (0.750)	23.88 (0.940)
10	.5625-24	4.78 (0.188)	7.92 (0.312)	20.62 (0.812)	23.88 (0.940)
12	.6875-24	7.92 (0.312)	11.13 (0.438)	23.83 (0.938)	23.88 (0.940)
14	.8125-20	9.53 (0.375)	14.27 (0.562)	26.97 (1.062)	30.23 (1.190)
16	.9375-20	12.70 (0.500)	15.88 (0.625)	28.58 (1.125)	30.23 (1.190)
18	1.0625-18	15.88 (0.625)	19.05 (0.750)	34.93 (1.375)	30.23 (1.190)
20	1.1875-18	15.88 (0.625)	19.05 (0.750)	34.93 (1.375)	30.23 (1.190)
22	1.3125-18	19.05 (0.750)	23.83 (0.938)	39.67 (1.562)	33.40 (1.315)
24	1.4375-18	20.32 (0.800)	25.40 (1.000)	42.06 (1.656)	33.40 (1.315)

For ordering information, please refer to page 18

# BACKSHELLS

## STRAIN RELIEFS

**M85049/49-2 strain relief** suitable for LJT (MIL-DTL-38999 series I / HE308) and RNJ (HE308) connectors.

**M85049/38 strain relief** suitable for TV-CTV (MIL-DTL-38999 series III), SC39 and RNJ LP connectors.

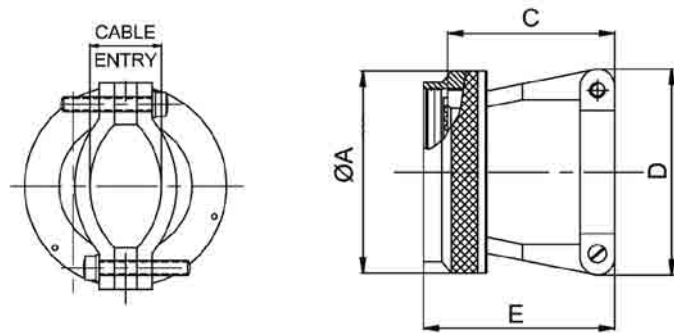

Size	Thread for M85049/49-2 UNEF-2B	Thread for M85049/38 Metric	Ø A max mm (in)	C max mm (in)	Ø D max mm (in)	E max mm (in)	Cable Entry mm (in)	
							min	max
09	.4375-28	M12 x 1.0 – 6H	19.05 (0.75)	23.11 (0.91)	21.59 (0.85)	27.94 (1.10)	2.49 (0.10)	5.94 (0.23)
11	.5625-24	M15 x 1.0 – 6H	21.59 (0.85)	23.11 (0.91)	22.86 (0.90)	27.94 (1.10)	3.89 (0.15)	5.94 (0.23)
13	.6875-24	M18 x 1.0 – 6H	25.40 (1.00)	25.65 (1.01)	27.94 (1.10)	30.48 (1.20)	4.83 (0.19)	8.33 (0.33)
15	.8125-20	M22 x 1.0 – 6H	27.94 (1.10)	26.92 (1.06)	29.21 (1.15)	31.75 (1.25)	6.60 (0.26)	11.61 (0.46)
17	.9375-20	M25 x 1.0 – 6H	31.75 (1.25)	29.46 (1.16)	33.02 (1.30)	34.44 (1.36)	7.19 (0.28)	15.60 (0.61)
19	1.0625-18	M28 x 1.0 – 6H	35.56 (1.40)	35.81 (1.41)	38.10 (1.50)	40.64 (1.60)	8.26 (0.33)	16.10 (0.63)
21	1.1875-18	M31 x 1.0 – 6H	38.10 (1.50)	38.35 (1.51)	40.64 (1.60)	43.21 (1.70)	8.71 (0.34)	17.73 (0.70)
23	1.3125-18	M34 x 1.0 – 6H	41.91 (1.65)	42.16 (1.66)	43.18 (1.70)	46.99 (1.85)	9.68 (0.38)	20.90 (0.82)
25	1.4375-18	M37 x 1.0 – 6H	44.45 (1.75)	44.70 (1.76)	45.72 (1.80)	49.56 (1.95)	10.62 (0.42)	21.67 (0.85)

### How to order M85049 strain reliefs

<b>Series</b>	M85049/	49-2	12	W
<b>Type of strain relief</b>	49-2: for LJT (MIL-DTL-38999 series I / HE308) and RNJ (HE308) connectors 38: for TV-CTV (MIL-DTL-38999 series III), SC39 and RNJ LP connectors			
<b>Size of backshell</b>	08-10-12-14-16-18-20-22-24 for LJT (MIL-DTL-38999 series I / HE308) and RNJ (HE308) connectors 09-11-13-15-17-19-21-23-25 (same as connector size) for TV-CTV (MIL-DTL-38999 series III), SC39 and RNJ LP connectors			
<b>Finish</b>	W: olive-drab cadmium plating N: electroless nickel plating			

## ADAPTERS FOR HEAT SHRINK MOULDED PIECES

These backshells ensure the sealing and the mechanical retention of the cable.

### NSD backshells

**LJT NSD** (HE308-14) suitable for LJT (MIL-DTL-38999 series I / HE308), RNJ (HE308) and SJT (VG96912) connectors.

**TV NSD** suitable for TV-CTV (MIL-DTL-38999 series III), SC39 and RNJ LP connectors.

For straight and right angled heat shrink moulded pieces, please refer to page 17-18.

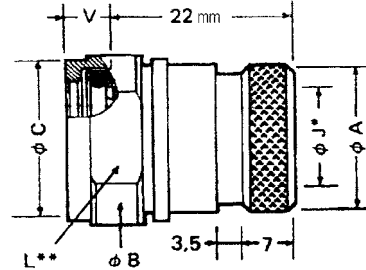

Size	A mm (in)	B <sup>±0.2</sup> mm (in)	C max mm (in)	J* min mm (in)	K max mm (in)	L** max mm (in)
9	12.60 (0.496)	20.00 (0.787)	16.00 (0.630)	7.80 (0.307)	9.50 (0.374)	16.80 (0.661)
11	16.40 (0.646)	23.00 (0.906)	19.00 (0.748)	10.80 (0.425)	12.50 (0.492)	20.80 (0.819)
13	20.00 (0.787)	26.00 (1.024)	22.00 (0.866)	13.10 (0.516)	15.50 (0.610)	22.80 (0.898)
15	22.00 (0.866)	29.00 (1.142)	25.10 (0.988)	16.30 (0.642)	18.50 (0.728)	25.80 (1.016)
17	24.60 (0.969)	32.00 (1.260)	28.30 (1.114)	19.00 (0.748)	21.50 (0.847)	28.80 (1.134)
19	27.50 (1.083)	35.00 (1.378)	31.30 (1.232)	21.70 (0.854)	24.00 (0.945)	31.80 (1.252)
21	31.90 (1.256)	39.00 (1.536)	34.50 (1.358)	24.90 (0.980)	27.00 (1.063)	35.80 (1.409)
23	35.00 (1.378)	42.00 (1.654)	37.70 (1.484)	28.10 (1.106)	30.50 (1.201)	38.80 (1.528)
25	38.80 (1.528)	45.00 (1.772)	40.80 (1.606)	31.20 (1.228)	33.50 (1.319)	41.80 (1.646)

\*\* dimension over the flats (4 flats)

## BACKSHELLS FOR POTTING

These backshells ensure the sealing.

### RPD backshells

**LJT RPD** suitable for LJT (MIL-DTL-38999 series I / HE308), RNJ (HE308) and JT (MIL-DTL-38999 series II) connectors.

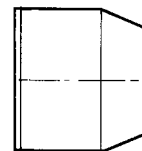

Size	A Thread UNEF-2B	B max mm (in)	Ø C mm (in)	Ø D mm (in)
09	.4375-28	20.06 (0.790)	14.80 (0.583)	8.30 (0.327)
11	.5625-24	20.06 (0.790)	18.00 (0.709)	11.30 (0.445)
13	.6875-24	20.06 (0.790)	21.10 (0.831)	14.20 (0.559)
15	.8125-20	20.06 (0.790)	24.30 (0.957)	17.30 (0.681)
17	.9375-20	20.06 (0.790)	27.50 (1.083)	20.50 (0.807)
19	1.0625-18	20.06 (0.790)	30.70 (1.209)	23.10 (0.909)
21	1.1875-18	21.56 (0.849)	33.90 (1.335)	26.30 (1.035)
23	1.3125-18	21.56 (0.849)	37.00 (1.457)	29.40 (1.158)
25	1.4375-18	20.86 (0.821)	40.20 (1.583)	32.60 (1.284)

For ordering information, please refer to page 18

# BACKSHELLS

## BACKSHELLS FOR POTTING

### RPC backshells

LJT RPC suitable for LJT (MIL-DTL-38999 series I / HE308), RNJ (HE308) and JT (MIL-DTL-38999 series II) connectors.

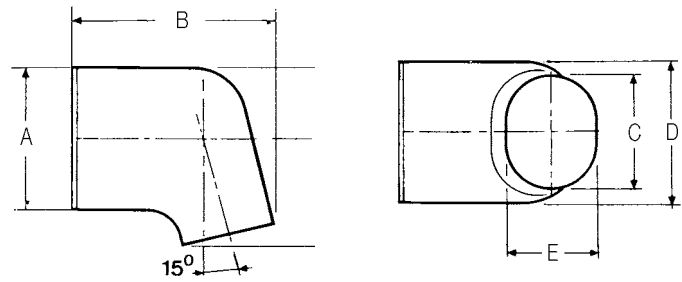

Size	A Thread UNEF-2B	B max mm (in)	$\varnothing C$ mm (in)	$\varnothing D$ mm (in)	$\varnothing E$ mm (in)	$\varnothing F$ max mm (in)
09	.4375-28	25.06 (0.987)	11.10 (0.437)	15.20 (0.598)	7.90 (0.311)	19.70 (0.776)
11	.5625-24	28.16 (1.109)	14.30 (0.563)	18.40 (0.724)	11.10 (0.437)	23.20 (0.913)
13	.6875-24	29.86 (1.176)	17.50 (0.689)	21.90 (0.862)	13.10 (0.516)	26.50 (1.043)
15	.8125-20	32.56 (1.282)	19.80 (0.780)	24.70 (0.972)	15.90 (0.626)	30.80 (1.213)
17	.9375-20	33.56 (1.321)	22.60 (0.890)	27.90 (1.098)	16.70 (0.656)	32.80 (1.291)
19	1.0625-18	34.86 (1.372)	25.40 (1.000)	31.10 (1.224)	17.90 (0.705)	35.50 (1.398)
21	1.1875-18	37.26 (1.467)	28.60 (1.126)	34.30 (1.350)	19.50 (0.768)	38.90 (1.531)
23	1.3125-18	38.16 (1.502)	31.30 (1.232)	37.40 (1.472)	20.60 (0.811)	41.60 (1.638)
25	1.4375-18	44.46 (1.750)	34.90 (1.374)	40.60 (1.598)	23.30 (0.917)	50.00 (1.969)



## HEAT-SHRINK MOULDED PIECES

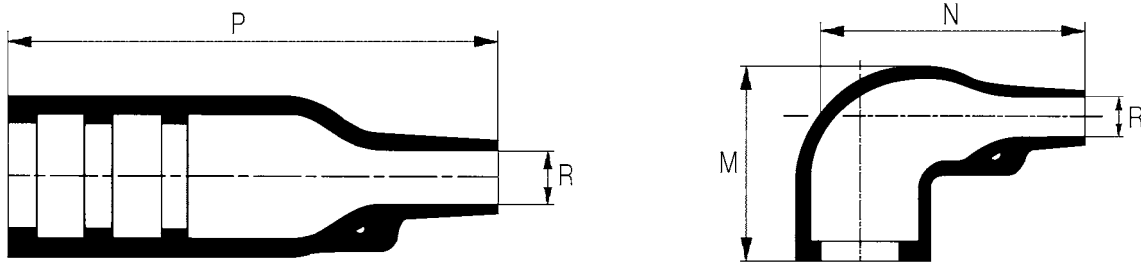

Heat-shrink moulded piece p/n		M max mm (in)	N ±10% mm (in)	p ±10% mm (in)	Ø r mm (in)	
Straight	Right angled				Before heating (max)	After heating (min cable Ø)
		<b>After total heating</b>				
804221	804231	25.40 (1.000)	25.00 (0.984)	38.40 (1.512)	24.00 (0.945)	6.00 (0.236)
814221	814231					
804222	804232	27.20 (1.071)	32.00 (1.260)	54.90 (2.161)	30.00 (1.181)	6.00 (0.236)
814222	814232					
804223	804233	30.50 (1.201)	39.40 (1.551)	66.80 (2.630)	31.00 (1.220)	7.10 (0.280)
814223	814233					
804225	804235	38.00 (1.496)	46.00 (1.811)	80.00 (3.150)	36.00 (1.417)	8.50 (0.335)
814225	814235					
804227	804237	45.00 (1.772)	55.00 (2.165)	99.10 (3.902)	43.00 (1.693)	10.00 (0.394)
814227	814237					
804229	804239	54.00 (2.126)	80.00 (3.150)	130.00 (5.118)	60.00 (2.362)	16.00 (0.630)
814229	814239					

Standard heat-shrink moulded pieces (semi-rigid polyolefin – without any adhesive)

Size	Backshell type	Rear size coding	Straight			Right angled		
			Amphenol Socapex p/n	Raychem p/n	Hellerman p/n	Amphenol Socapex p/n	Raychem p/n	Hellerman p/n
9	NSA, NSB, NSD	-	804221	202K121-3	152-42-G	804231	222K121-3	1152-4-G
	HE308-35, TV35, TVB35, SBC	08	804221	202K121-3	152-42-G	804231	222K121-3	1152-4-G
11	NSA, NSB, NSD	-	804222	202K132-3	154-42-G	804232	222K132-3	1154-4-G
	HE308-35, TV35, TVB35, SBC	12	804222	202K132-3	154-42-G	804232	222K132-3	1154-4-G
13	NSA, NSB, NSD	-	804223	202K142-3	155-42-G	804233	222K142-3	1155-4-G
	HE308-35, TV35, TVB35, SBC	12	804222	202K132-3	154-42-G	804232	222K132-3	1154-4-G
		16	804223	202K142-3	155-42-G	804233	222K142-3	1155-4-G
15	NSA	-	804225	202K153-3	156-42-G	804235	222K152-3	1156-4-G
	NSB, NSD	-	804223	202K142-3	155-42-G	804233	222K142-3	1155-4-G
	HE308-35, TV35, TVB35, SBC	14	804222	202K132-3	154-42-G	804232	222K132-3	1154-4-G
		20	804225	202K153-3	156-42-G	804235	222K152-3	1156-4-G
17	NSA	-	804227	202K163-3	157-43-G	804237	222K163-3	1157-4-G
	NSB, NSD	-	804225	202K153-3	156-42-G	804235	222K152-3	1156-4-G
	HE308-35, TV35, TVB35, SBC	12	804222	202K132-3	154-42-G	804232	222K132-3	1154-4-G
		16	804223	202K142-3	155-42-G	804233	222K142-3	1155-4-G
		24	804225	202K153-3	156-42-G	804235	222K152-3	1156-4-G
19	NSA	-	804227	202K163-3	157-43-G	804237	222K163-3	1157-4-G
	NSB, NSD	-	804225	202K153-3	156-42-G	804235	222K152-3	1156-4-G
	HE308-35, TV35, TVB35, SBC	16	804223	202K142-3	155-42-G	804233	222K142-3	1155-4-G
		24	804225	202K153-3	156-42-G	804235	222K152-3	1156-4-G
21	NSA, NSB, NSD	-	804227	202K163-3	157-43-G	804237	222K163-3	1157-4-G
	HE308-35, TV35, TVB35, SBC	14	804222	202K132-3	154-42-G	804232	222K132-3	1154-4-G
		20	804225	202K153-3	156-42-G	804235	222K152-3	1156-4-G
		28	804227	202K163-3	157-43-G	804237	222K163-3	1157-4-G
23	NSA, NSB, NSD	-	804229	202K174-3	158-43-G	804239	222K174-3	1158-4-G
	HE308-35, TV35, TVB35, SBC	24	804225	202K153-3	156-42-G	804235	222K152-3	1156-4-G
		32	804227	202K163-3	157-43-G	804237	222K163-3	1157-4-G
25	NSA, NSB, NSD	-	804229	202K174-3	158-43-G	804239	222K174-3	1158-4-G
	HE308-35, TV35, TVB35, SBC	28	804227	202K163-3	157-43-G	804237	222K163-3	1157-4-G
		36	804229	202K174-3	158-43-G	804239	222K174-3	1158-4-G

# BACKSHELLS

## HOW TO ORDER

### Amphenol designation - Backshells for LJT (MIL-DTL-38999 series I / HE308), RNJ (HE308) and SJT\* (VG96912) connectors

Series	LJT	NSA	11	014	-
<b>Type of backshell</b>					
<b>NSA:</b> screened clamping braid backshell accepting heat shrink moulded piece					
<b>SQ:</b> simple screened clamping braid backshell accepting heat shrink moulded piece					
<b>NSB:</b> screened soldering braid backshell accepting heat shrink moulded piece					
<b>NSD:</b> backshell for heat shrink moulded piece					
<b>RPD:</b> straight backshell for potting					
<b>RPC:</b> 75° angled backshell for potting					
<b>Size of backshell</b> 09-11-13-15-17-19-21-23-25					
<i>for LJT connectors: same as connector size</i>					
<i>for SJT (G)06 and 00 connectors: greater than the connector size by 1</i>					
<i>for SJT07 sizes 8 to 22 connectors: greater than the connector size by 3</i>					
<i>Consult us for SJT07 size 24 connector</i>					
<b>Finish</b>					
<b>014:</b> olive-drab cadmium plating					
<b>023:</b> electroless nickel plating					
<b>Deviation</b>					
<b>F428:</b> backshells for SJT* connectors only					

\* : for NSA, NSB, NSD, SQ only

### Amphenol designation – Backshells for TV-CTV (MIL-DTL-38999 series III), SC39 and RNJ LP connectors

Series	TV	NSA	11	014
<b>Type of backshell</b>				
<b>NSA:</b> screened clamping braid backshell accepting heat shrink moulded piece				
<b>NSD:</b> backshell for heat shrink moulded piece				
<b>Size of backshell</b> 09-11-13-15-17-19-21-23-25 (same as connector size)				
<b>Finish</b>				
<b>014:</b> olive-drab cadmium plating				
<b>023:</b> electroless nickel plating				

### HE 308 military designation – Backshells for HE 308 (LJT / MIL-DTL-38999 series I / RNJ) connectors

Series	HE 308	13	15	7	M
<b>Type of backshell</b>					
<b>13:</b> screened clamping braid backshell accepting heat shrink moulded piece					
<b>14:</b> backshell for heat shrink moulded piece					
<b>15:</b> straight backshell for potting					
<b>Size of backshell</b> 09-11-13-15-17-19-21-23-25 (same as connector size)					
<b>Finish</b>					
<b>7:</b> olive-drab cadmium plating					
<b>6:</b> electroless nickel plating					
<b>Military standard</b>					

### Amphenol designation – Backshells for JT (MIL-DTL-38999 series II) connectors

Series	JT	SA	12	014
<b>Type of backshell</b>				
<b>SA:</b> screened clamping braid backshell accepting heat shrink moulded piece				
<b>SRD :</b> straight cable clamp				
<b>RPD:</b> straight backshell for potting				
<b>RPC:</b> 75° angled backshell for potting				
<b>Size of backshell</b> 08-10-12-14-16-18-20-22-24 (same as connector size)				
<b>Finish</b>				
<b>014:</b> olive-drab cadmium plating				
<b>023:</b> electroless nickel plating				



## TORQUES VALUES FOR REAR ACCESSORIES

According to the MIL-C-85049 standard

For LJT / RNJ / HE308 / MIL-DTL-38999 I connectors		For JT / MIL-DTL-38999 II connectors		For TV-CTV / MIL-DTL-38999 III connectors			For SJT / VG96912 connectors	
Shell size	Max torque value (N.m)	Shell size	Max torque value (N.m)	Shell size	Metal Max torque value (N.m)	Composite Max torque value (N.m)	Shell size	Max torque value (N.m)
09	5.0	08	5.0	09	7.2	5.0	08	5.0
11	5.0	10	5.0	11	9.5	5.0	10	5.0
13	5.0	12	5.0	13	13.1	5.0	12	5.0
15	5.0	14	5.0	15	14.0	5.0	14	5.0
17	5.0	16	5.0	17	14.0	5.0	16	5.0
19	5.0	18	5.0	19	14.0	5.0	18	5.0
21	9.5	20	9.5	21	16.3	9.5	20	9.5
23	9.5	22	9.5	23	16.3	9.5	22	9.5
25	9.5	24	9.5	25	16.3	9.5	24	9.5

## CROSS REFERENCES

The cross references below are given as information only. The designs of the backshells are not strictly equivalent.

Amphenol p/n	NFC UTE 93422 / HE308 p/n	MIL-C-85049 p/n	VG96912 p/n
LJT NSA xx 014	HE308 13 xx 7M	-	-
LJT NSA xx 023	HE308 13 xx 6M	-	-
LJT SQ xx 014 F428	-	-	VG96912 L xx
HE308-35-xx-xx-xx-7M	HE308-35-xx-xx-xx-7M	-	-
HE308-35-xx-xx-xx-6M	HE308-35-xx-xx-xx-6M	-	-
JT SRD xx 014	-	M85049/49-2-xx W	-
JT SRD xx 023	-	M85049/49-2-xx N	-
LJT NSD xx 014	HE308 14 xx 7M	M85049/62-xx W	-
LJT NSD xx 023	HE308 14 xx 6M	-	-
LJT NSD xx 014 F428	-	-	VG96912 F1 xx
LJT RPD xx 014	HE308 15 xx 7M	M85049/58-xx + M85049/75-xx-1	-
LJT RPD xx 023	HE308 15 xx 6M	-	-
LJT RPC xx 014	HE308 16 xx 7M	-	-
LJT RPC xx 023	HE308 16 xx 6M	-	-

## NORTH AMERICA

**Amphenol Pcd, Inc.**  
72 Cherry Hill Drive  
Beverly, MA, 01915 - USA  
Telephone: +1-978-624-3400

## EUROPE

**Amphenol AIR LB**  
10 Rue Champ Raymond  
08110 Cartignan - France  
Telephone: +33-3-2422-3270  
Fax: +33-3-2422-387

**Amphenol AIR LB GmbH**  
Am Kleinbahnhof 4 - 66740 Saarlouis - Germany  
Telephone: +49-6531-951-00  
Fax: +49-6831-981-030

**Amphenol BENELUX**  
Zadelmaker 121 NL - 2401 PD Alphen aan den Rijn  
The Netherlands  
Telephone: +31-172-444-903  
Fax: +31-172-240-254

**Amphenol IBERICA**  
Edificio "Burgosol"  
c/Comunidad de Madrid, 35 bis Oficina No 55  
E5 - 28230 Las Rozas - Madrid - Spain  
Telephone: +34-91-640-73-02/03/04  
Fax: +34-91-640-73-07

**Amphenol ITALIA**  
Via Barbalana n.5, 20020 Lainate - Milano - Italy  
Telephone: +39-02-93254-1  
Fax: +39-02-93254-444

**Amphenol LIMITED**  
Thanet Way, Whitstable - Kent, CT5 3JF  
United Kingdom  
Telephone: +44-1227-773-200  
Fax: +44-1227-276-571

**Amphenol MIDDLE & EASTERN EUROPE**  
Wiener gase 68 - 2380 Perchtoldsdorf - Austria  
Telephone: +43-699-10396-071  
Fax: +43-699-40396-071

**SEFEE**  
ZI des Cazes - BP 243  
12403 Saint Affrique - France  
Telephone: +33-5-6598-1100  
Fax: +33-5-6549-3712

**Amphenol SCANDINAVIA**  
Angsullsvägen 7 - S-187 51 Täby - Sweden  
Telephone: +46-702-12-92-00  
Fax: +46-702-63-46-77

**Amphenol SOCAPEX**  
948 Promenade de l'Arve - BP29  
74311 Thyez Cedex - France  
Telephone: +33-4-5089-2800  
Fax: +33-4-5096-1941

**Amphenol SOUTH EASTERN EUROPE**  
948 Promenade de l'Arve - BP29  
74311 Thyez Cedex - France  
Telephone: +33-4-5089-2800  
Fax: +33-4-5096-1941

## ASIA

**Amphenol DAESHIN**  
558 Sosa, SongNea  
Bucheon-city, Kyunggi-Do  
Korea 420-130  
Telephone: +82-32-610-3800  
Fax: +82-32-673-2507/665-6219

**Amphenol INTERCONNECT INDIA PRIVATE LIMITED**  
105 Bhosari Industrial Area  
Pune 411 026 - India  
Telephone: +91-20-712-0363/0463/0155  
Fax: +91-20-712-0581

**Amphenol JAPAN**  
689-1, Iseochi  
Ritto-shi Shiga 520-3044 - Japan  
Telephone: +81-77-553-8501  
Fax: +81-77-551-2200

**Amphenol PCD CO.LTD**  
2/F Building A5,  
Huafeng Technology Park  
Guan Tian, Bei Huan Road,  
Shi Yan Street  
BaoAn District, Shenzhen,  
China 518132  
Tel: +86-755-8173-8281  
Fax: +86-755-8173-8180

## OTHER AREAS

**Amphenol ARGENTINA**  
Av. Callao 930 2do piso Oficina B "Plaza"  
C1023 - AAP Buenos Aires - Argentina  
Telephone: +54-11-4815-6886  
Fax: +54-11-4814-5779

**Amphenol AUSTRALIA PTY LIMITED**  
2 Fiveways Blvd, Keysborough  
Melbourne, Victoria 3173 - Australia  
Telephone: +61-3-8796-8888  
Fax: +61-3-8796-8801

**BAR TEC LTD**  
4 Hagavish St, PO Box 279  
Kfar Saba 44102 - Israel  
Telephone: +972-9-767-4097  
Fax: +972-9-767-4324

**Amphenol DO BRAZIL**  
Rua Diodo Moreira, 132, 20 andar, rooms 2001-2-3  
CEP: 05423-010 Sao Paulo SP - Brazil  
Telephone: +55-11-3815-1003  
Fax: +55-11-3815-1629

**Amphenol MEXICO**  
Prolongacion Reforma 61 - 6 B2  
Col. Paseo de las Lomas - C.P.013130 - Mexico  
Telephone: +52-55-5258-9984  
Fax: +52-55-5081-6890

**Amphenol RUSSIA**  
8 bldg., 2 Yaroslavskaja Street,  
129164 Moscow - Russia  
Telephone: +7-495-937-6341  
Fax: +7-495-937-6319

**Amphenol SOUTH AFRICA**  
30 Impala Road  
2196 Chislehurst-Sandton - South Africa  
Telephone: +27-11-783-9517  
Fax: +27-11-783-9519

**Amphenol TURKEY**  
Sun Plaza Kat:15  
Maslak Mah. Bilim Sok.No:15  
34398 Şişli - İstanbul  
Telephone: +90-212-367-9220  
Fax: +90-212-367-9221

### AMPHENOL SOCAPEX

948 Promenade de l'Arve - B. P. 29  
74311 Thyez Cedex - France - Telephone: 33-4-5089-2800 - Fax: 33-4-5096-1941

**Amphenol**  
Socapex

The information given in this document are as a guideline only.  
We reserve the right to modify our products in any way we deem necessary.  
Any duplication is prohibited, unless approved in writing.  
Realisation: wanagenstudios - Steven Kilgallon

For more information, please visit our website:  
[www.amphenol-socapex.com](http://www.amphenol-socapex.com)

Компания «Океан Электроники» предлагает заключение долгосрочных отношений при поставках импортных электронных компонентов на взаимовыгодных условиях!

Наши преимущества:

- Поставка оригинальных импортных электронных компонентов напрямую с производств Америки, Европы и Азии, а так же с крупнейших складов мира;
- Широкая линейка поставок активных и пассивных импортных электронных компонентов (более 30 млн. наименований);
- Поставка сложных, дефицитных, либо снятых с производства позиций;
- Оперативные сроки поставки под заказ (от 5 рабочих дней);
- Экспресс доставка в любую точку России;
- Помощь Конструкторского Отдела и консультации квалифицированных инженеров;
- Техническая поддержка проекта, помощь в подборе аналогов, поставка прототипов;
- Поставка электронных компонентов под контролем ВП;
- Система менеджмента качества сертифицирована по Международному стандарту ISO 9001;
- При необходимости вся продукция военного и аэрокосмического назначения проходит испытания и сертификацию в лаборатории (по согласованию с заказчиком);
- Поставка специализированных компонентов военного и аэрокосмического уровня качества (Xilinx, Altera, Analog Devices, Intersil, Interpoint, Microsemi, Actel, Aeroflex, Peregrine, VPT, Syfer, Eurofarad, Texas Instruments, MS Kennedy, Miteq, Cobham, E2V, MA-COM, Hittite, Mini-Circuits, General Dynamics и др.);

Компания «Океан Электроники» является официальным дистрибьютором и эксклюзивным представителем в России одного из крупнейших производителей разъемов военного и аэрокосмического назначения «JONHON», а так же официальным дистрибьютором и эксклюзивным представителем в России производителя высокотехнологичных и надежных решений для передачи СВЧ сигналов «FORSTAR».



## JONHON

«JONHON» (основан в 1970 г.)

Разъемы специального, военного и аэрокосмического назначения:

(Применяются в военной, авиационной, аэрокосмической, морской, железнодорожной, горно- и нефтедобывающей отраслях промышленности)

«FORSTAR» (основан в 1998 г.)

ВЧ соединители, коаксиальные кабели, кабельные сборки и микроволновые компоненты:

(Применяются в телекоммуникациях гражданского и специального назначения, в средствах связи, РЛС, а так же военной, авиационной и аэрокосмической отраслях промышленности).



Телефон: 8 (812) 309-75-97 (многоканальный)

Факс: 8 (812) 320-03-32

Электронная почта: [ocean@oceanchips.ru](mailto:ocean@oceanchips.ru)

Web: <http://oceanchips.ru/>

Адрес: 198099, г. Санкт-Петербург, ул. Калинина, д. 2, корп. 4, лит. А