

## Demonstration board for PWD5F60 smart driver with integrated high voltage full bridge

Data brief

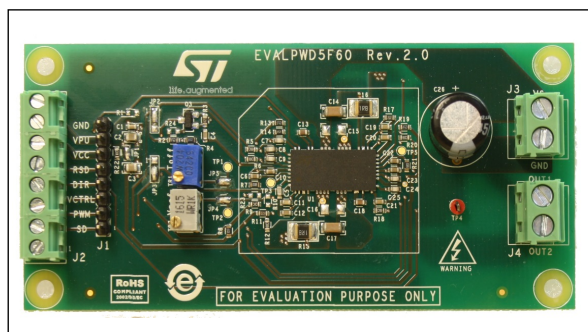

### Features

- Power system-in-package integrating gate drivers and power MOSFETs featuring:
  - $R_{DS(ON)} = 1.38 \Omega$
  - $BV_{DSS} = 600 \text{ V}$
  - 2 embedded comparators
- Very low area occupation, all active devices in SMT technology and no heatsink
- Fast-decay or slow-decay on-board constant OFF-time peak current control
- PWM voltage mode control with overcurrent protection possible via external logic signals
- Driver supply voltage range: 10 V to 20 V
- UVLO protection on low-side and high-side
- 3.3 V to 15 V compatible inputs with hysteresis and pull-down
- Internal bootstrap diode
- Bill of materials reduction
- Very compact and simplified layout
- Flexible, easy and fast design
- RoHS compliant
- Load current up to 1 A

### Description

The PWD5F60 is an advanced power system-in-package integrating gate drivers and four N-channel power MOSFETs in a compact QFN package.

The integrated power MOSFETs have an  $R_{DS(ON)}$  of  $1.38 \Omega$  and 600 V drain-source breakdown voltage. The embedded gate drivers feature two comparators that can be used for peak current control or overcurrent protection and integrate bootstrap diodes. This allows to effectively drive loads in a tiny space and to drastically reduce external components and bill of materials.

The EVALPWD5F60 demonstrates how to use the PWD5F60 to drive a single-phase load in full-bridge topology. This allows control of both the direction and the value of the current flowing into the load. Typical applications that can benefit from the high integration of the PWD5F60 are, for example, single-phase BLDC motors and fans.

The board has a very small footprint and an optimized layout thanks to the integrated features of the PWD5F60, and it can be simply run by applying the supply voltages and a direction signal.

The board allows easy selection and modification of the relevant external component values, enabling fast performance evaluation under different applicative conditions as well as fine tuning of final application components.

# 1 Board description

**Table 1. EVALPWD5F60 electrical specifications**

Parameter	Value
Max supply voltage range (VS) <sup>(1)</sup>	400 V <sub>DC</sub>
Driver supply voltage (Vcc)	10 to 20 V
Logic control signals	0 to 15 V
Junction to ambient thermal resistance RJA <sup>(2)</sup>	30 °C/W
Operating temperature range	-40 °C to +125 °C

1. Maximum VS voltage is limited by the electrolytic bulk capacitor (C26) voltage rating; PWD5F60 BVDSS is 600 V.
2. Measured with uniform dissipation on the power MOSFETs

**Figure 1. Jumpers and connectors location**

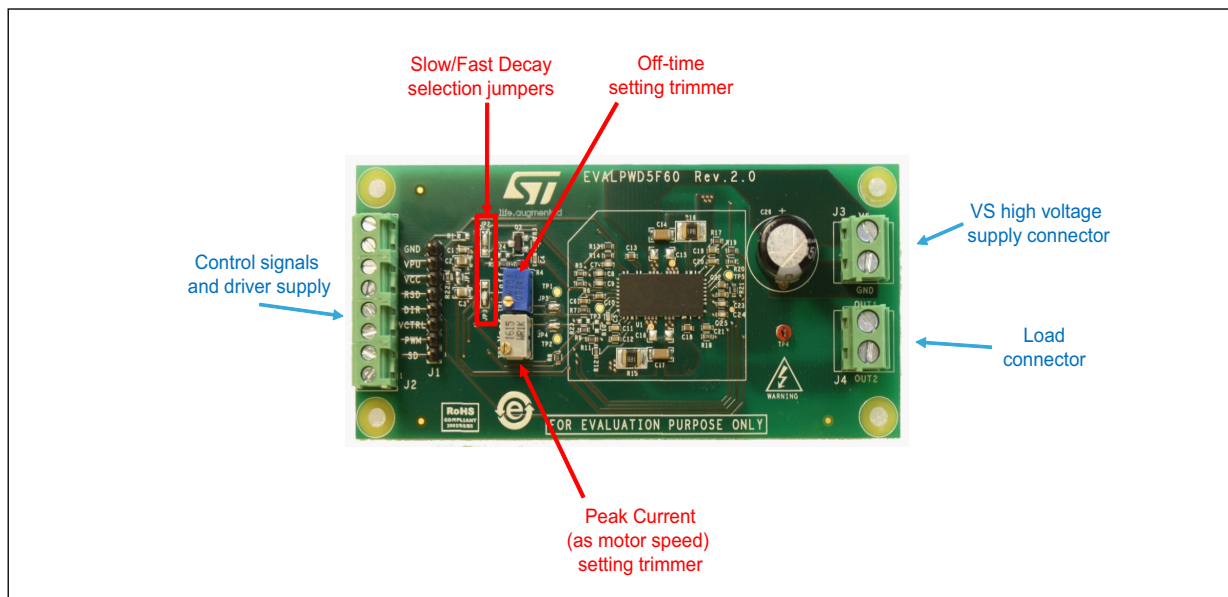

**Table 2. Jumpers and connectors description**

Name	Type	Function
J1	Control signals connector	VCC and logic control signals, pin strip header
J2	Control signals connector	VCC and logic control signals, terminal block connector
J3	Power supply	VS high voltage power supply connector
J4	Power output	Load connector
JP1	Configuration jumper	To connect $V_{PU}$ pull-up voltage to VCC
JP2	Configuration jumper	To pull-up SD or PWM signals to $V_{PU}$ pull-up voltage
JP3	Configuration jumper	To connect SD or PWM signal to CPOUT2
JP4	Configuration jumper	To use trimmer TR2 for setting the peak current instead of R10
JP5	Configuration jumper	To use trimmer TR1 for setting OFF-time duration after overcurrent detection instead of R23

**Table 3. Control signals connector pinout (J1 - J2)**

Pin	Label	Type	Description
1	SD	Digital input	Drivers' SD signal
2	PWM	Digital input	Drivers' PWM signal
3	VCTRL	Analog / PWM input	$V_{ctrl}$ signal, sets current limit threshold (as motor speed)
4	DIR	Digital input	DIR signal, sets current's direction (as from Hall sensor)
5	RSD	Reserved	Reserved
6	VCC	Power supply	Drivers' $V_{CC}$ power supply
7	VPU	Power supply	$V_{PU}$ pull-up voltage for drivers' signals. Close JP1 to connect to VCC
8	GND	Power supply	GND

# 2 Schematic diagram

Figure 2. EVALPWD5F60 circuit schematic

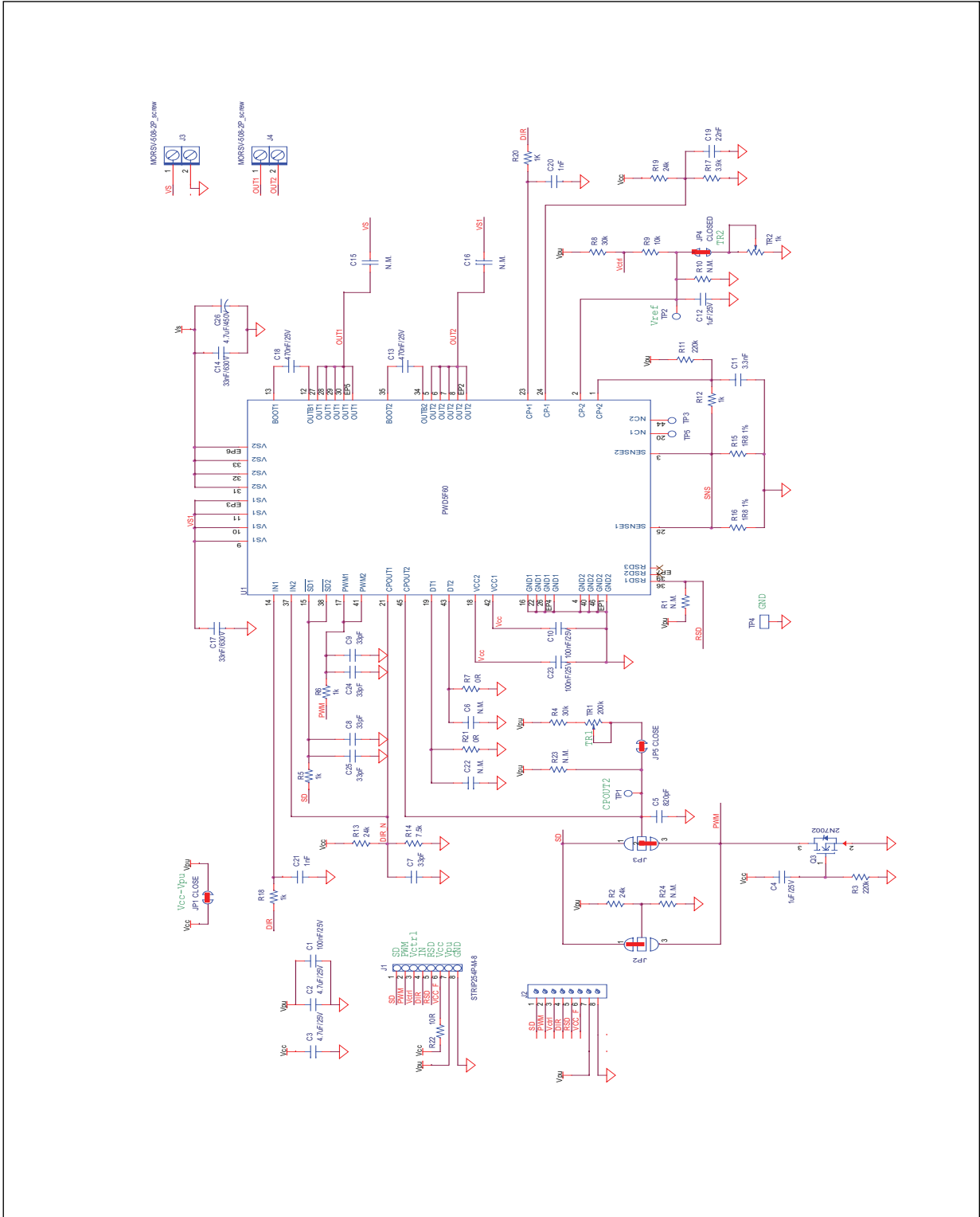

**Table 4. EVALPWD5F60 - Bill Of Materials**

Part reference	Part value	Part description
C7, C8, C9, C24, C25	33 pF	Ceramic capacitor, SMT 0603
C5	820 pF	Ceramic capacitor, SMT 0603
C11	3.3 nF	Ceramic capacitor, SMT 0603
C19	22 nF	Ceramic capacitor, SMT 0603
C1, C10, C23	100 nF / 25 V	Ceramic capacitor, SMT 0603
C13, C18	470 nF / 25 V	Ceramic capacitor, SMT 0603
C4, C12	1 $\mu$ F / 25 V	Ceramic capacitor, SMT 0603
C6, C22	N.M.	Ceramic capacitor, SMT 0603
C2, C3	4.7 $\mu$ F / 25 V	Ceramic capacitor, SMT 0805
C14, C17	33 nF / 630 V	Ceramic capacitor, SMT 1206
C15, C16	N.M.	Ceramic capacitor, SMT 1206
C26	4.7 $\mu$ F / 450 V - 20%	Electrolytic capacitor, T.H. D10 H12.5 P5
JP1, JP4, JP5	Jumper - CLOSED	SMT jumper - 2 poles
JP2	Jumper - 1-2 CLOSED	SMT jumper - 3poles
JP3	Jumper - 2-3 CLOSED	SMT jumper - 3 poles
J1	STRIP254P-M-8	Pin strip header 2.54 mm, 8 poles
J2	Screw connector	Conn. term. block T.H. 8 POS 3.5 mm
J3, J4	Screw connector	Conn. term. block T.H. 2 POS 5.08 mm
R1, R10, R23, R24	N.M.	Resistor, SMT 0603
R2, R13, R19	24 k $\Omega$	Resistor, SMT 0603
R4, R8	30 k $\Omega$	Resistor, SMT 0603
R5, R6, R12, R18, R20	1 k $\Omega$	Resistor, SMT 0603
R7, R21	0 $\Omega$	Resistor, SMT 0603
R9	10 k $\Omega$	Resistor, SMT 0603
R3, R11	220 k $\Omega$	Resistor, SMT 0603
R14	7.5 k $\Omega$	Resistor, SMT 0603
R15, R16	1.8 $\Omega$ - 1 %	Resistor, SMT 1210
R17	3.9 $\Omega$	Resistor, SMT 0603
R22	10 $\Omega$	Resistor, SMT 0603
TP1, TP2, TP3, TP5	Test point SMD	SMD test point 50 mils
TP4	Ring test point	Test point PCB 1 mm T.H.
TR1	200 k $\Omega$	Trimmer 1/4 W - Bourns 3266 W

Table 4. EVALPWD5F60 - Bill Of Materials (continued)

Part reference	Part value	Part description
TR2	1 k $\Omega$	Trimmer 1/4 W - Bourns 3266 W
U1	PWD5F60	PWD5F60, VFQFPN 15x7
Q3	2N7002	60 V small signal N-channel MOSFET, SOT23-3L

Figure 3. EVALPWD5F60 - layout (top layer)

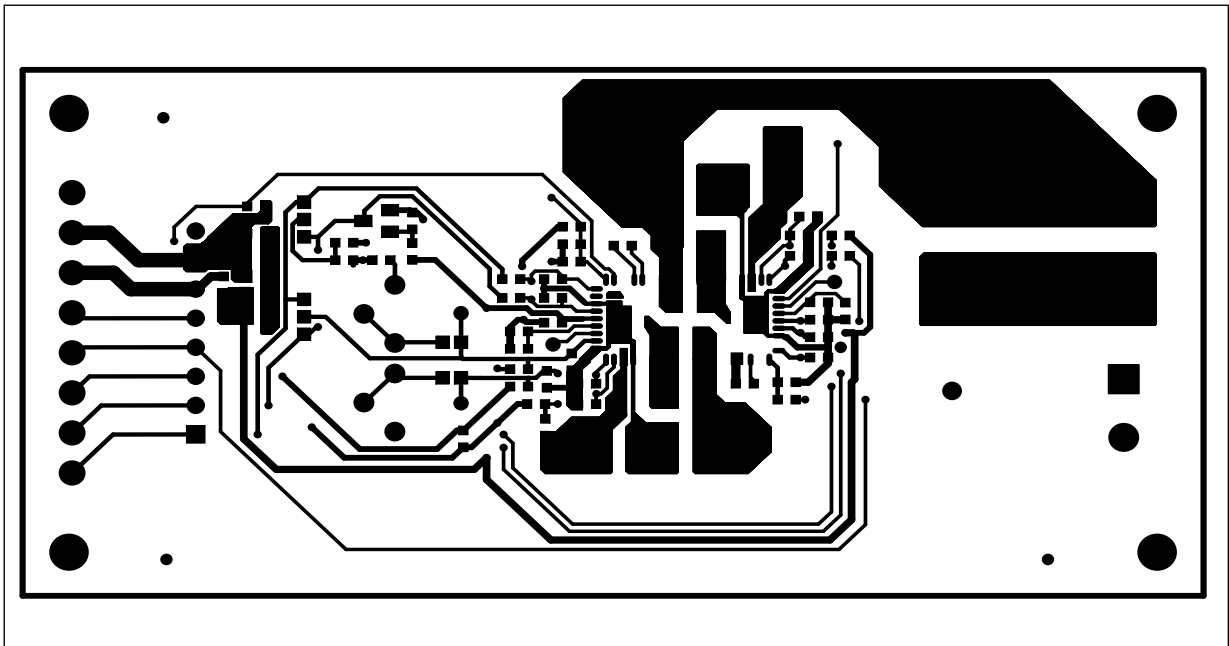

Figure 4. EVALPWD5F60 - layout (bottom layer)

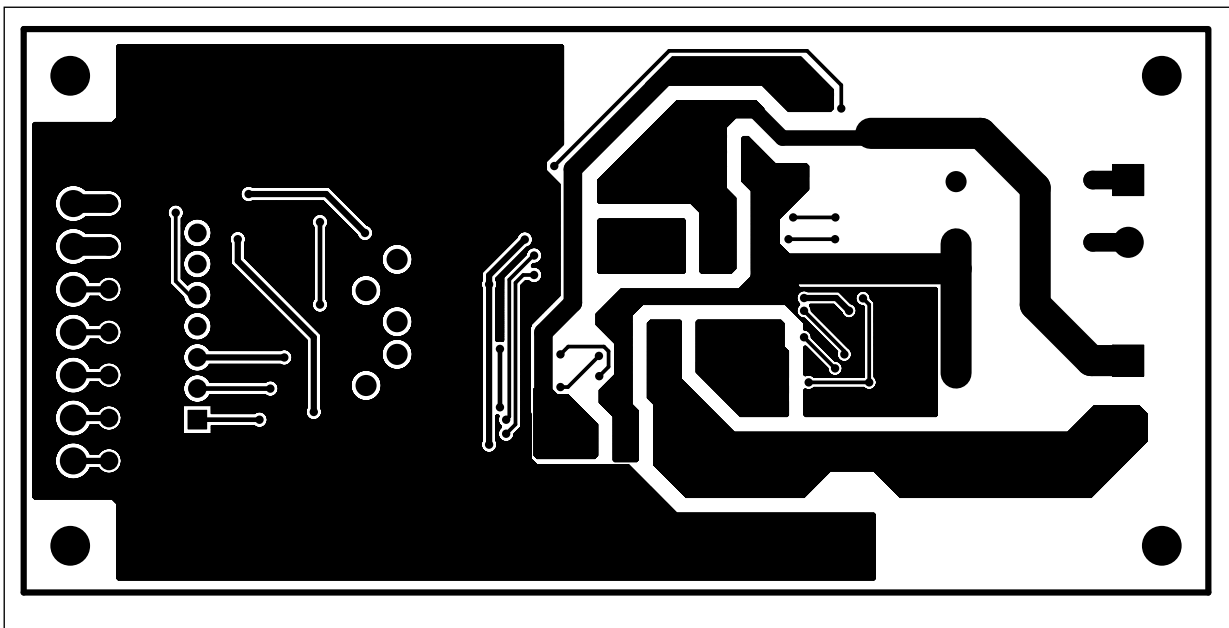
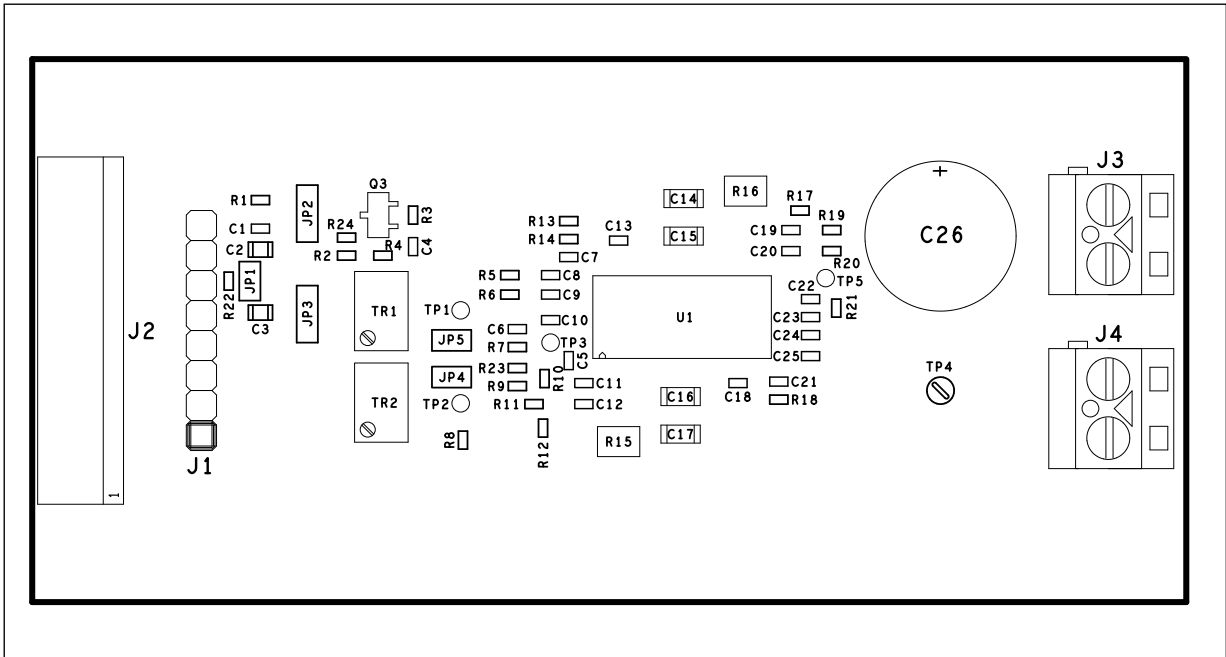

Figure 5. EVALPWD5F60 - layout (component placement view)





### 3 Revision history

Table 5. Document revision history

Date	Revision	Changes
29-Aug-2018	1	Initial release

**IMPORTANT NOTICE – PLEASE READ CAREFULLY**

STMicroelectronics NV and its subsidiaries ("ST") reserve the right to make changes, corrections, enhancements, modifications, and improvements to ST products and/or to this document at any time without notice. Purchasers should obtain the latest relevant information on ST products before placing orders. ST products are sold pursuant to ST's terms and conditions of sale in place at the time of order acknowledgement.

Purchasers are solely responsible for the choice, selection, and use of ST products and ST assumes no liability for application assistance or the design of Purchasers' products.

No license, express or implied, to any intellectual property right is granted by ST herein.

Resale of ST products with provisions different from the information set forth herein shall void any warranty granted by ST for such product.

ST and the ST logo are trademarks of ST. All other product or service names are the property of their respective owners.

Information in this document supersedes and replaces information previously supplied in any prior versions of this document.

© 2018 STMicroelectronics – All rights reserved

Компания «Океан Электроники» предлагает заключение долгосрочных отношений при поставках импортных электронных компонентов на взаимовыгодных условиях!

Наши преимущества:

- Поставка оригинальных импортных электронных компонентов напрямую с производств Америки, Европы и Азии, а так же с крупнейших складов мира;
- Широкая линейка поставок активных и пассивных импортных электронных компонентов (более 30 млн. наименований);
- Поставка сложных, дефицитных, либо снятых с производства позиций;
- Оперативные сроки поставки под заказ (от 5 рабочих дней);
- Экспресс доставка в любую точку России;
- Помощь Конструкторского Отдела и консультации квалифицированных инженеров;
- Техническая поддержка проекта, помощь в подборе аналогов, поставка прототипов;
- Поставка электронных компонентов под контролем ВП;
- Система менеджмента качества сертифицирована по Международному стандарту ISO 9001;
- При необходимости вся продукция военного и аэрокосмического назначения проходит испытания и сертификацию в лаборатории (по согласованию с заказчиком);
- Поставка специализированных компонентов военного и аэрокосмического уровня качества (Xilinx, Altera, Analog Devices, Intersil, Interpoint, Microsemi, Actel, Aeroflex, Peregrine, VPT, Syfer, Eurofarad, Texas Instruments, MS Kennedy, Miteq, Cobham, E2V, MA-COM, Hittite, Mini-Circuits, General Dynamics и др.);

Компания «Океан Электроники» является официальным дистрибьютором и эксклюзивным представителем в России одного из крупнейших производителей разъемов военного и аэрокосмического назначения «JONHON», а так же официальным дистрибьютором и эксклюзивным представителем в России производителя высокотехнологичных и надежных решений для передачи СВЧ сигналов «FORSTAR».



## JONHON

«JONHON» (основан в 1970 г.)

Разъемы специального, военного и аэрокосмического назначения:

(Применяются в военной, авиационной, аэрокосмической, морской, железнодорожной, горно- и нефтедобывающей отраслях промышленности)

«FORSTAR» (основан в 1998 г.)

ВЧ соединители, коаксиальные кабели, кабельные сборки и микроволновые компоненты:

(Применяются в телекоммуникациях гражданского и специального назначения, в средствах связи, РЛС, а так же военной, авиационной и аэрокосмической отраслях промышленности).



Телефон: 8 (812) 309-75-97 (многоканальный)

Факс: 8 (812) 320-03-32

Электронная почта: [ocean@oceanchips.ru](mailto:ocean@oceanchips.ru)

Web: <http://oceanchips.ru/>

Адрес: 198099, г. Санкт-Петербург, ул. Калинина, д. 2, корп. 4, лит. А