

DESCRIPTION

Demonstration circuit 810 is a high efficiency buck-boost flash LED driver featuring the LTC®3453 and the LXCL-PWF1 Lumileds Luxeon Flash. The board is optimized for 500mA 300ms LED flash current or 150mA constant LED torch current with a single Lithium-Ion battery input voltage range of 2.7V to 4.2V or three AAA batteries in series. The Lithium-Ion battery input voltage range, high LED flash current and separate torch mode current setting, internal synchronous power switches, minimal and low-profile external components, and simple design makes the LTC3453 the top solution for highly efficient, space-constrained cellular telephone camera flash solutions.

DC810 comes with three AAA batteries in series to simulate the capabilities of a typical Lithium-Ion cellular telephone battery. This portable board is turned on and off by pressing the ON/OFF button. A TORCH button turns the LED on at 150mA for cellular telephone video recording. The FLASH button flashes the LED at 500mA for 300ms for cellular telephone camera flash operation. The buttons control the state of the PIC microcontroller IC that is programmed with DC810 software. The PIC keeps the LED from being flashed constantly, preventing overheating and burnout. The PIC also controls the flash time. When no buttons are pressed for a short time, the PIC turns off and the

circuit enters low-power mode for battery-life preservation.

A red/green LED indicates the state of the PIC. The LED is ready to flash or torch if the state indicator is blipping green. If the indicator is not on, the PIC is turned off. For a brief time after the flash has occurred, the state-indicator LED is red, indicating that another flash cannot happen, even if the button is pressed, until the red LED is off and the green LED is blipping again.

The LTC3453 datasheet gives a complete description of the part, operation and applications information. The datasheet must be read in conjunction with this Quick Start Guide for demonstration circuit 810. In addition, Lumileds Luxeon Flash datasheet featuring LXCL-PWF1 (www.lumileds.com) must be read to understand thermal and LED current constraints for varying flash current pulse-widths and intensity. The LTC3453 is assembled in a small low profile QFN package. Proper board layout is essential for maximum thermal performance. See the datasheet section 'Layout Considerations'.

Design files for this circuit board are available. Call the LTC factory.

LT is a trademark of Linear Technology Corporation

QUICK START PROCEDURE

Demonstration circuit 810 is easy to set up to evaluate the performance of the LTC3453. Follow the procedure below:

NOTE: Make sure that the input voltage does not exceed 5V if a source other than the three AAA batteries is used.

NOTE: If batteries are not used, do not hot-plug the input voltage terminals VIN (+) and GND (-). The absolute maximum voltage on VIN is 5.5V and hot-

plugging a power supply through wire leads to the demonstration circuit can cause the voltage on the extremely low-ESR ceramic input capacitor to ring to twice its DC value. *See Application Note 88 for more details.*

NOTE: Connect the three AAA batteries as indicated in the battery pack with the polarity indicated on the back of the PCB.

QUICK START GUIDE FOR DEMONSTRATION CIRCUIT 810

HIGH EFFICIENCY BUCK-BOOST FLASH LED DRIVER

1. Insert three AAA batteries in the battery pack on the back of the PCB.
2. If the state-indicator LED is not blipping green, press the ON/OFF button to turn on the circuit.
3. Press 'FLASH' to observe a 300ms, 500mA camera flash on the LXCL-PWF1 LED.
4. Press 'TORCH' to observe constant 150mA LED light for recording video.
5. Press 'TORCH' to turn off the 150mA video mode.
6. Press 'ON/OFF' to turn off the circuit or let the circuit turn off by not pressing any buttons for approximately 10 seconds.

QUICK START GUIDE FOR DEMONSTRATION CIRCUIT 810

HIGH EFFICIENCY BUCK-BOOST FLASH LED DRIVER

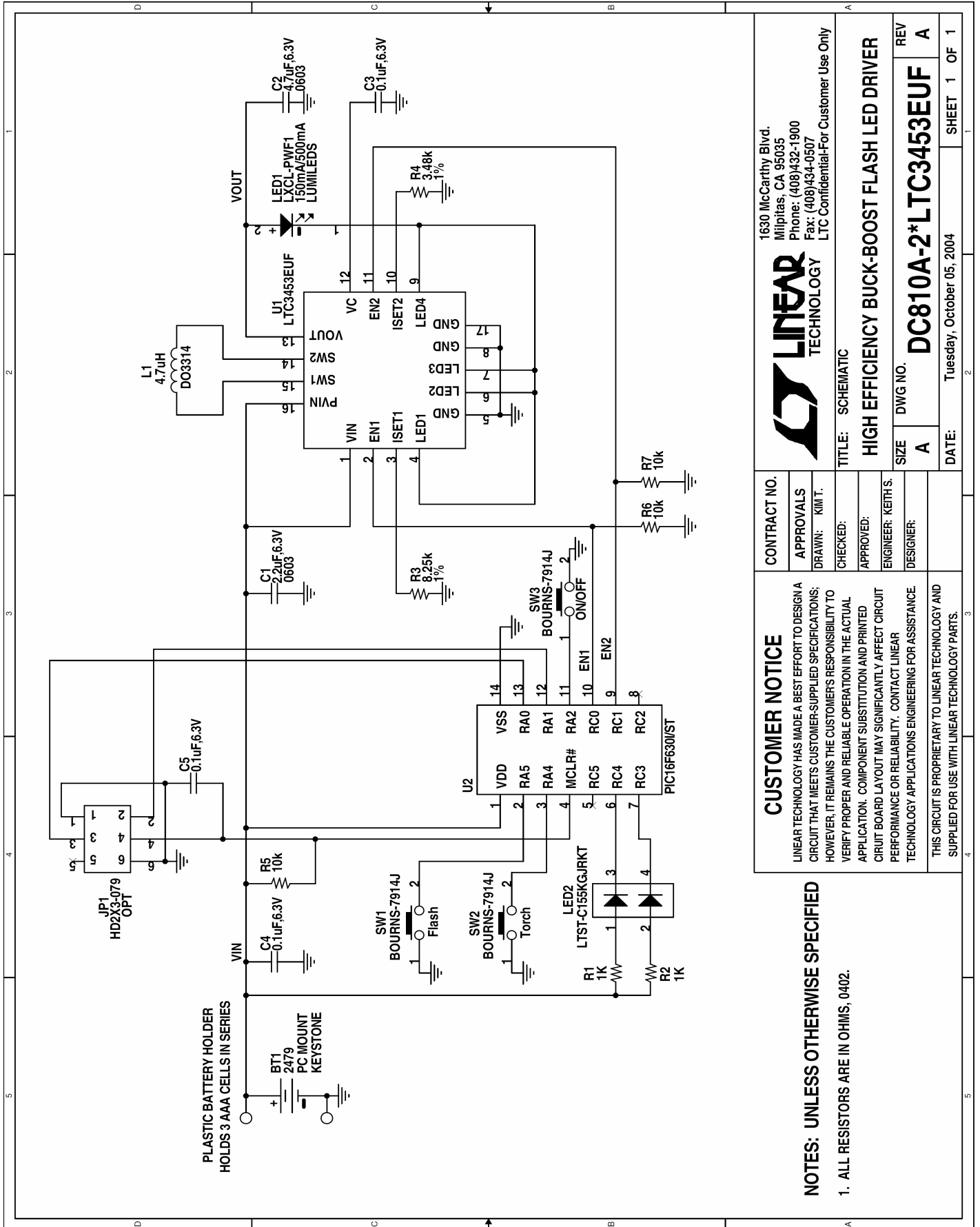

LINEAR TECHNOLOGY
 1630 McCarthy Blvd.
 Milpitas, CA 95035
 Phone: (408)432-1900
 Fax: (408)434-0507
 LTC Confidential-For Customer Use Only

LINEAR TECHNOLOGY

TITLE: SCHEMATIC

HIGH EFFICIENCY BUCK-BOOST FLASH LED DRIVER

SIZE: A DWG NO.: **DC810A-2*LTC3453EUF** REV: A

DATE: Tuesday, October 05, 2004 SHEET 1 OF 1

CUSTOMER NOTICE

LINEAR TECHNOLOGY HAS MADE A BEST EFFORT TO DESIGN A CIRCUIT THAT MEETS CUSTOMER-SUPPLIED SPECIFICATIONS; HOWEVER, IT REMAINS THE CUSTOMER'S RESPONSIBILITY TO VERIFY PROPER AND RELIABLE OPERATION IN THE ACTUAL APPLICATION. COMPONENT SUBSTITUTION AND PRINTED CIRCUIT BOARD LAYOUT MAY SIGNIFICANTLY AFFECT CIRCUIT PERFORMANCE OR RELIABILITY. CONTACT LINEAR TECHNOLOGY APPLICATIONS ENGINEERING FOR ASSISTANCE.

THIS CIRCUIT IS PROPRIETARY TO LINEAR TECHNOLOGY AND SUPPLIED FOR USE WITH LINEAR TECHNOLOGY PARTS.

NOTES: UNLESS OTHERWISE SPECIFIED

1. ALL RESISTORS ARE IN OHMS, 0402.

Компания «Океан Электроники» предлагает заключение долгосрочных отношений при поставках импортных электронных компонентов на взаимовыгодных условиях!

Наши преимущества:

- Поставка оригинальных импортных электронных компонентов напрямую с производств Америки, Европы и Азии, а так же с крупнейших складов мира;
- Широкая линейка поставок активных и пассивных импортных электронных компонентов (более 30 млн. наименований);
- Поставка сложных, дефицитных, либо снятых с производства позиций;
- Оперативные сроки поставки под заказ (от 5 рабочих дней);
- Экспресс доставка в любую точку России;
- Помощь Конструкторского Отдела и консультации квалифицированных инженеров;
- Техническая поддержка проекта, помощь в подборе аналогов, поставка прототипов;
- Поставка электронных компонентов под контролем ВП;
- Система менеджмента качества сертифицирована по Международному стандарту ISO 9001;
- При необходимости вся продукция военного и аэрокосмического назначения проходит испытания и сертификацию в лаборатории (по согласованию с заказчиком);
- Поставка специализированных компонентов военного и аэрокосмического уровня качества (Xilinx, Altera, Analog Devices, Intersil, Interpoint, Microsemi, Actel, Aeroflex, Peregrine, VPT, Syfer, Eurofarad, Texas Instruments, MS Kennedy, Miteq, Cobham, E2V, MA-COM, Hittite, Mini-Circuits, General Dynamics и др.);

Компания «Океан Электроники» является официальным дистрибьютором и эксклюзивным представителем в России одного из крупнейших производителей разъемов военного и аэрокосмического назначения «JONHON», а так же официальным дистрибьютором и эксклюзивным представителем в России производителя высокотехнологичных и надежных решений для передачи СВЧ сигналов «FORSTAR».



JONHON

«JONHON» (основан в 1970 г.)

Разъемы специального, военного и аэрокосмического назначения:

(Применяются в военной, авиационной, аэрокосмической, морской, железнодорожной, горно- и нефтедобывающей отраслях промышленности)

«FORSTAR» (основан в 1998 г.)

ВЧ соединители, коаксиальные кабели, кабельные сборки и микроволновые компоненты:

(Применяются в телекоммуникациях гражданского и специального назначения, в средствах связи, РЛС, а так же военной, авиационной и аэрокосмической отраслях промышленности).



Телефон: 8 (812) 309-75-97 (многоканальный)

Факс: 8 (812) 320-03-32

Электронная почта: ocean@oceanchips.ru

Web: <http://oceanchips.ru/>

Адрес: 198099, г. Санкт-Петербург, ул. Калинина, д. 2, корп. 4, лит. А