

## 150 mA Voltage Regulator (Wide Input Voltage Range) for High Temperature Applications

NO. EA-346-140319

### OUTLINE

The R1514x is a positive voltage regulator (VR) IC featuring 150 mA output current that is developed with CMOS process technology. The R1514xxxxB has features of high input voltage and ultra-low supply current. A peak current limit circuit, a short current limit circuit, and a thermal shutdown circuit are built in the R1514x. R1514x is very suitable for power source of industrial equipments such as FAs and smart meters since its operating temperature is  $-40^{\circ}\text{C}$  to  $105^{\circ}\text{C}$  and the maximum input voltage is 36 V.

The output voltage is fixed in the R1514xxxxB and can be selected from the following: 2.5 V / 2.8 V / 3.0 V / 3.3 V / 3.4 V / 5.0 V / 6.0 V / 8.0 V / 8.5 V / 9.0 V / 12.0 V. The Output voltage accuracy is  $\pm 2\%$ .

The packages for this IC are the SOT-89-5 for space saving and the HSOP-6J for higher power applications.

### FEATURES

- Input Voltage Range (Maximum Rating) ..... 4 V to 36 V (50 V)
- Operating Temperature .....  $-40^{\circ}\text{C}$  to  $105^{\circ}\text{C}$  (※)
- Supply Current ( $I_{SS}$ ) ..... Typ. 9  $\mu\text{A}$
- Standby Current ( $I_{standby}$ ) ..... Typ. 0.1  $\mu\text{A}$
- Temperature-Drift Coefficient of Output Voltage... Typ.  $\pm 100$  ppm/ $^{\circ}\text{C}$
- Output Current ( $I_{OUT}$ ) ..... Min. 150 mA ( $V_{IN} = V_{OUT} + 3.0$  V; R1514x050B)
- Line Regulation..... Typ. 0.05%/V
- Output Voltage Accuracy .....  $\pm 2\%$
- Output Voltage Range ( $V_{OUT}$ ) ..... 2.5V / 2.8V / 3.0V / 3.3V / 3.4V / 5.0V / 6.0V / 8.0V /  
8.5V / 9.0V / 12.0V  
Contact Ricoh sales representatives for other voltages.
- Packages ..... SOT-89-5, HSOP-6J
- Built-in Short Current Limit Circuit..... Typ. 50 mA
- Built-in Peak Current Limit Circuit
- Built-in Thermal Shutdown Circuit

※ This product is usable for the high-temperature applications since have passed a test at the high temperature. In addition, this product has a high-reliability since having passed Ricoh's rigorous quality standards. To distinguish from the consumer products, "-Yx" is added at the end of the product name.

### APPLICATIONS

- Industrial equipments such as FAs and smart meters
- Equipments used under high-temperature conditions
- Equipments accompanied by self-heating

### BLOCK DIAGRAM

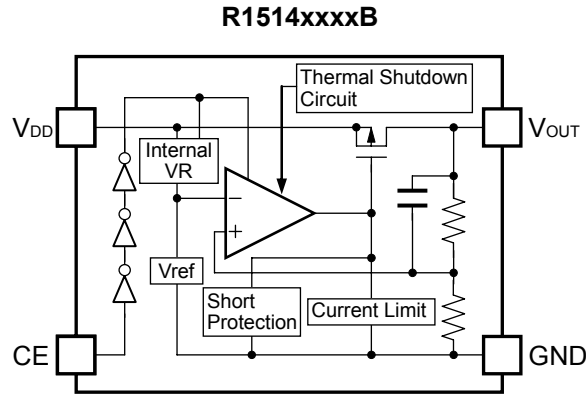

### SELECTION GUIDE

The output voltage, package for the ICs can be selected at the user's request.

Product Name	Package	Quantity per Reel	Pb Free	Halogen Free
R1514HxxxB-T1-YE	SOT-89-5	1,000 pcs	Yes	Yes
R1514SxxxB-E2-YE	HSOP-6J	1,000 pcs	Yes	Yes

xxx: Specify the set output voltage ( $V_{SET}$ )  
2.5 V (025) / 2.8 V (028) / 3.0 V (030) / 3.3 V (033) / 3.4 V (034) / 5.0 V (050) / 6.0 V (060) /  
8.0 V (080) / 8.5 V (085) / 9.0 V (090) / 12.0 V (120)

## PIN DESCRIPTIONS

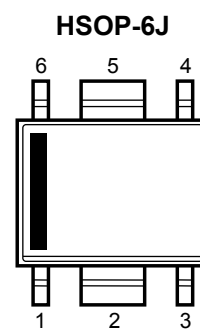
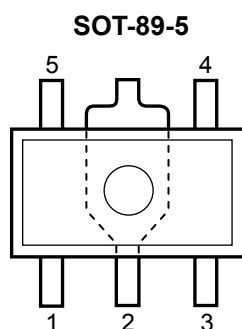

### SOT-89-5

Pin No.	Symbol	Description
1	$V_{OUT}$	Output Pin
2	GND <sup>*1</sup>	Ground Pin
3	CE	Chip Enable Pin, Active-high.
4	GND <sup>*1</sup>	Ground Pin
5	$V_{DD}$	Input Pin

<sup>\*1</sup> The GND pin must be wired together when it is mounted on board.

### HSOP-6J

Pin No.	Symbol	Description
1	$V_{OUT}$	Output Pin
2	GND <sup>*2</sup>	Ground Pin
3	CE	Chip Enable Pin, Active-high.
4	GND <sup>*2</sup>	Ground Pin
5	GND <sup>*2</sup>	Ground Pin
6	$V_{DD}$	Input Pin

<sup>\*2</sup> The GND pin must be wired together when it is mounted on board.

**ABSOLUTE MAXIMUM RATINGS**

Symbol	Item	Rating	Unit	
V <sub>IN</sub>	Input Voltage	-0.3 to 50	V	
V <sub>IN</sub>	Peak Input Voltage <sup>*3</sup>	60	V	
V <sub>CE</sub>	Input Voltage (CE Pin)	-0.3 to V <sub>IN</sub> + 0.3 ≤ 50	V	
V <sub>OUT</sub>	Output Voltage	-0.3 to V <sub>IN</sub> + 0.3 ≤ 50	V	
I <sub>OUT</sub>	Output Current	250	mA	
P <sub>D</sub>	Power Dissipation (SOT-89-5) <sup>*4</sup>	Standard Land Pattern	900	mW
		High Wattage Land Pattern	1300	
	Power Dissipation (HSOP-6J) <sup>*4</sup>	Standard Land Pattern	1700	
		Ultra High Wattage Land Pattern	2700	
T <sub>j</sub>	Junction Temperature	-40 to 125	°C	
T <sub>stg</sub>	Storage Temperature Range	-55 to 125	°C	

<sup>\*3</sup> Duration time = 200 ms

<sup>\*4</sup> Refer to *PACKAGE INFORMATION* for detailed information.

**ABSOLUTE MAXIMUM RATINGS**

Electronic and mechanical stress momentarily exceeded absolute maximum ratings may cause the permanent damages and may degrade the life time and safety for both device and system using the device in the field. The functional operation at or over these absolute maximum ratings is not assured.

**RECOMMENDED OPERATING CONDITIONS**

Symbol	Item	Rating	Unit
V <sub>IN</sub>	Input Voltage	4 to 36	V
T <sub>a</sub>	Operating Temperature Range	-40 to 105	°C

**RECOMMENDED OPERATING CONDITIONS**

All of electronic equipment should be designed that the mounted semiconductor devices operate within the recommended operating conditions. The semiconductor devices cannot operate normally over the recommended operating conditions, even if when they are used over such conditions by momentary electronic noise or surge. And the semiconductor devices may receive serious damage when they continue to operate over the recommended operating conditions.

## ELECTRICAL CHARACTERISTICS

$V_{IN} = V_{SET} + 3.0 \text{ V}$ ,  $C_{IN} = 0.1 \mu\text{F}$ ,  $C_{OUT} = 0.1 \mu\text{F}$ , unless otherwise noted.

The specifications surrounded by   are guaranteed by design engineering at  $-40^\circ\text{C} \leq T_a \leq 105^\circ\text{C}$ .

### R1514xxxxB

( $T_a = 25^\circ\text{C}$ )

Symbol	Item	Conditions	Min.	Typ.	Max.	Unit
$I_{SS}$	Supply Current	$I_{OUT} = 0 \text{ mA}$		9	<span style="border: 1px solid black; padding: 0 2px;">20</span>	$\mu\text{A}$
$I_{standby}$	Standby Current	$V_{IN} = 36 \text{ V}$ , $V_{CE} = 0 \text{ V}$		0.1	<span style="border: 1px solid black; padding: 0 2px;">1.0</span>	$\mu\text{A}$
$V_{OUT}$	Output Voltage	$I_{OUT} = 1 \text{ mA}$	$T_a = 25^\circ\text{C}$	x 0.98	x 1.02	V
			$-40^\circ\text{C} \leq T_a \leq 105^\circ\text{C}$	<span style="border: 1px solid black; padding: 0 2px;">x 0.97</span>	<span style="border: 1px solid black; padding: 0 2px;">x 1.03</span>	
$I_{OUT}$	Output Current		Refer to the <i>Product-specific Electrical Characteristics</i>			
$\Delta V_{OUT}/\Delta I_{OUT}$	Load Regulation	$1 \text{ mA} \leq I_{OUT} \leq 40 \text{ mA}$	Refer to the <i>Product-specific Electrical Characteristics</i>			
$\Delta V_{OUT}/\Delta V_{IN}$	Line Regulation	$V_{OUT} + 1.5 \text{ V} \leq V_{IN} \leq 36 \text{ V}$ , $I_{OUT} = 1 \text{ mA}$		0.05	<span style="border: 1px solid black; padding: 0 2px;">0.20</span>	%/V
$V_{DIF}$	Dropout Voltage	$I_{OUT} = 20 \text{ mA}$	Refer to the <i>Product-specific Electrical Characteristics</i>			
$I_{SC}$	Short Current Limit	$V_{OUT} = 0 \text{ V}$		50		mA
$V_{CEH}$	CE Input Voltage "H"		<span style="border: 1px solid black; padding: 0 2px;">1.5</span>		$V_{IN}$	V
$V_{CEL}$	CE Input Voltage "L"		0.0		<span style="border: 1px solid black; padding: 0 2px;">0.3</span>	V
$T_{TSD}$	Thermal Shutdown Temperature	Junction Temperature		160		$^\circ\text{C}$
$T_{TSR}$	Thermal Shutdown Released Temperature	Junction Temperature		130		$^\circ\text{C}$

All test items listed under Electrical Characteristics are done under the pulse load condition ( $T_j \approx T_a = 25^\circ\text{C}$ ).

### Product-specific Electrical Characteristics

( $T_a = 25^\circ\text{C}$ )

Product Name	$V_{OUT} \text{ (V)}$					$I_{OUT} \text{ (mA)}$		$\Delta V_{OUT}/\Delta I_{OUT} \text{ (mV)}$		$V_{DIF} \text{ (V)}$		
	$T_a = 25^\circ\text{C}$			$-40^\circ\text{C} \leq T_a \leq 105^\circ\text{C}$		$T_a = 25^\circ\text{C}$	$-40^\circ\text{C} \leq T_a \leq 105^\circ\text{C}$			$T_a = 25^\circ\text{C}$	$-40^\circ\text{C} \leq T_a \leq 105^\circ\text{C}$	$-40^\circ\text{C} \leq T_a \leq 105^\circ\text{C}$
	MIN.	TYP.	MAX.	MIN.	TYP.	MIN.	MIN.	TYP.	MAX.	TYP.	MAX.	MAX.
R1514x025B	2.450	2.500	2.550	<span style="border: 1px solid black; padding: 0 2px;">2.425</span>	<span style="border: 1px solid black; padding: 0 2px;">2.575</span>	100	<span style="border: 1px solid black; padding: 0 2px;">90</span>	10	<span style="border: 1px solid black; padding: 0 2px;">25</span>	/	1.5	<span style="border: 1px solid black; padding: 0 2px;">1.5</span>
R1514x028B	2.744	2.800	2.856	<span style="border: 1px solid black; padding: 0 2px;">2.716</span>	<span style="border: 1px solid black; padding: 0 2px;">2.884</span>						1.2	<span style="border: 1px solid black; padding: 0 2px;">1.2</span>
R1514x030B	2.940	3.000	3.060	<span style="border: 1px solid black; padding: 0 2px;">2.910</span>	<span style="border: 1px solid black; padding: 0 2px;">3.090</span>	1.0	<span style="border: 1px solid black; padding: 0 2px;">1.0</span>					
R1514x033B	3.234	3.300	3.366	<span style="border: 1px solid black; padding: 0 2px;">3.201</span>	<span style="border: 1px solid black; padding: 0 2px;">3.399</span>	0.7	<span style="border: 1px solid black; padding: 0 2px;">0.7</span>					
R1514x034B	3.332	3.400	3.468	<span style="border: 1px solid black; padding: 0 2px;">3.298</span>	<span style="border: 1px solid black; padding: 0 2px;">3.502</span>	0.6	<span style="border: 1px solid black; padding: 0 2px;">0.7</span>					
R1514x050B	4.900	5.000	5.100	<span style="border: 1px solid black; padding: 0 2px;">4.850</span>	<span style="border: 1px solid black; padding: 0 2px;">5.150</span>	150	<span style="border: 1px solid black; padding: 0 2px;">150</span>	20	<span style="border: 1px solid black; padding: 0 2px;">35</span>	0.20	0.35	<span style="border: 1px solid black; padding: 0 2px;">0.40</span>
R1514x060B	5.880	6.000	6.120	<span style="border: 1px solid black; padding: 0 2px;">5.820</span>	<span style="border: 1px solid black; padding: 0 2px;">6.180</span>							
R1514x080B	7.840	8.000	8.160	<span style="border: 1px solid black; padding: 0 2px;">7.760</span>	<span style="border: 1px solid black; padding: 0 2px;">8.240</span>							
R1514x085B	8.330	8.500	8.670	<span style="border: 1px solid black; padding: 0 2px;">8.245</span>	<span style="border: 1px solid black; padding: 0 2px;">8.755</span>							
R1514x090B	8.820	9.000	9.180	<span style="border: 1px solid black; padding: 0 2px;">8.730</span>	<span style="border: 1px solid black; padding: 0 2px;">9.270</span>							
R1514x120B	11.760	12.000	12.240	<span style="border: 1px solid black; padding: 0 2px;">11.640</span>	<span style="border: 1px solid black; padding: 0 2px;">12.360</span>							

## TYPICAL APPLICATION

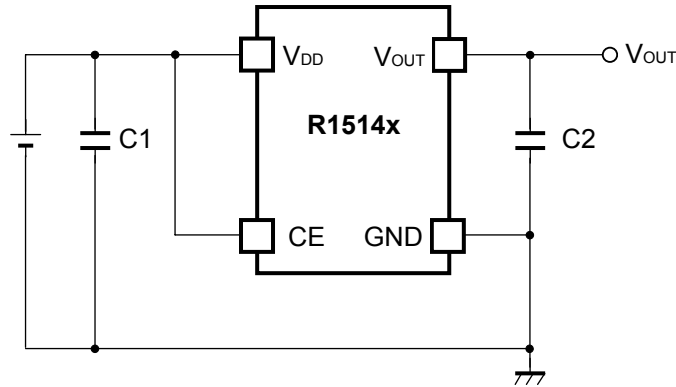

### External Components:

C1 (C <sub>IN</sub> )	0.1 $\mu$ F (Ceramic)
C2 (C <sub>OUT</sub> )	0.1 $\mu$ F (Ceramic)

## TECHNICAL NOTES

### PCB Layout

Ensure the  $V_{DD}$  and GND lines are sufficiently robust. If their impedance is too high, noise pickup or unstable operation may result. Connect a capacitor with a suitable value between the  $V_{DD}$  and GND, and as close as possible to the pins.

### Phase Compensation

Phase Compensation of the R1514x has been made internally for stable operation even though the load current would vary. Therefore, without the capacitors, C1 and C2, the output voltage is regulated, however, for more stable operation, use capacitors as C1 and C2. Especially, if the input line is long and impedance is high, C1 is necessary. Moreover, if you use rather large C2, transient response will be improved. Recommended value is in the range from 0.1  $\mu$ F to 10  $\mu$ F. Wiring should be made as short as possible.

Connect the capacitor, C1 between  $V_{DD}$  pin and GND and C2 between  $V_{OUT}$  and GND as close as possible.

### Thermal Shutdown

Thermal shutdown function is included in the R1514x, if the junction temperature is more than or equal to 160°C (Typ.), the operation of regulator would stop. After that, when the junction temperature is less than or equal to 130°C (Typ.), the operation of regulator would restart. Unless the cause of rising temperature would remove, the regulator repeats on and off, and output waveform would be like consecutive pulses.

### Chip Enable Circuit

Do not make voltage level of chip enable pin keep floating level, or in between  $V_{CEH}$  and  $V_{CEL}$ . Otherwise, the output voltage would be unstable or indefinite, or unexpected current would flow internally.

## TYPICAL APPLICATION FOR IC CHIP BREAKDOWN PREVENTION

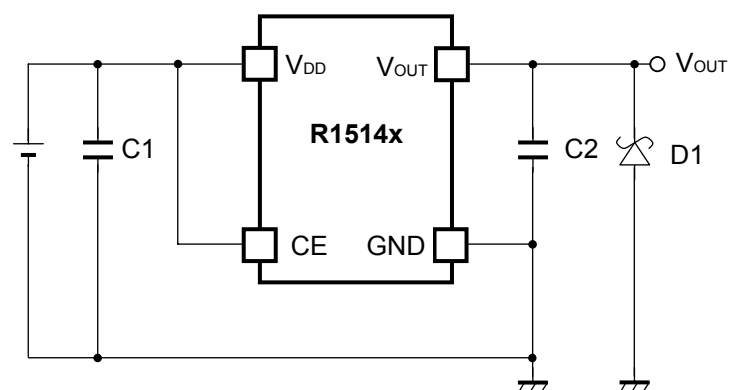

When a sudden surge of electrical current travels along the V<sub>OUT</sub> pin and GND due to a short-circuit, electrical resonance of a circuit involving an output capacitor (C2) and a short circuit inductor generates a negative voltage and may damage the device or the load devices. Connecting a schottky diode (D1) between the V<sub>OUT</sub> pin and GND has the effect of preventing damage to them.

**PACKAGE INFORMATION**

**POWER DISSIPATION (SOT89-5)**

Power Dissipation ( $P_D$ ) depends on conditions of mounting on board. This specification is based on the measurement at the condition below:

**Measurement Conditions (SOT89-5)**

	High Wattage Land Pattern	Standard Land Pattern
Environment	Mounting on board (Wind velocity = 0 m/s)	Mounting on board (Wind velocity = 0 m/s)
Board Material	Glass cloth epoxy plastic (Double sided)	Glass cloth epoxy plastic (Double sided)
Board Dimensions	30 mm x 30 mm x 1.6 mm	50 mm x 50 mm x 1.6 mm
Copper Ratio	Top side: Approx. 20% , Back side: Approx. 100%	Top side: Approx. 10% , Back side: Approx. 100%
Through-hole	$\phi$ 0.85 mm x 10 pcs	-

**Measurement Result (SOT89-5)**

( $T_a = 25^\circ\text{C}$ ,  $T_{j\text{max}} = 125^\circ\text{C}$ )

	High Wattage Land Pattern	Standard Land Pattern	Free Air
Power Dissipation	1300 mW	900 mW	500 mW
Thermal Resistance	77°C/W	111°C/W	200°C/W

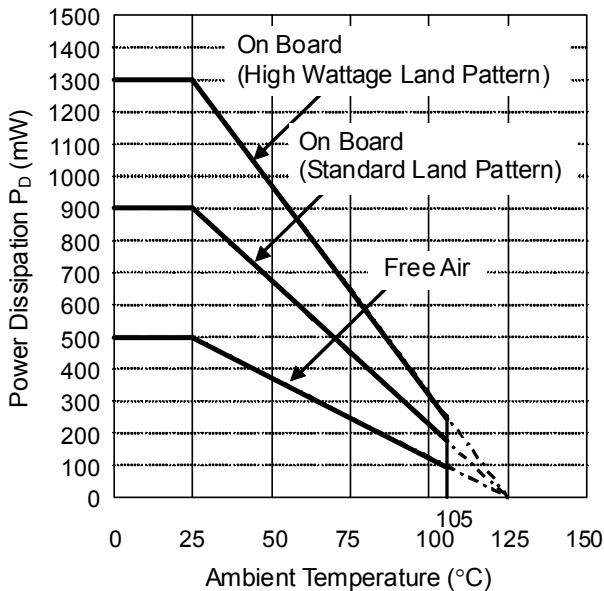

**Power Dissipation vs. Ambience Temperature (SOT89-5)**

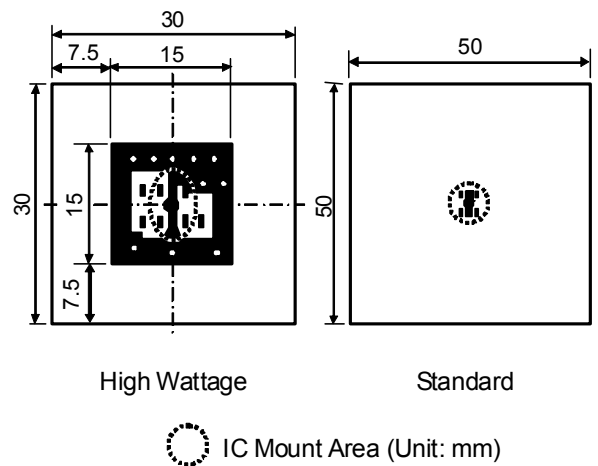

**Measurement Board Pattern (SOT89-5)**



**PACKAGE DIMENSIONS (SOT89-5)**

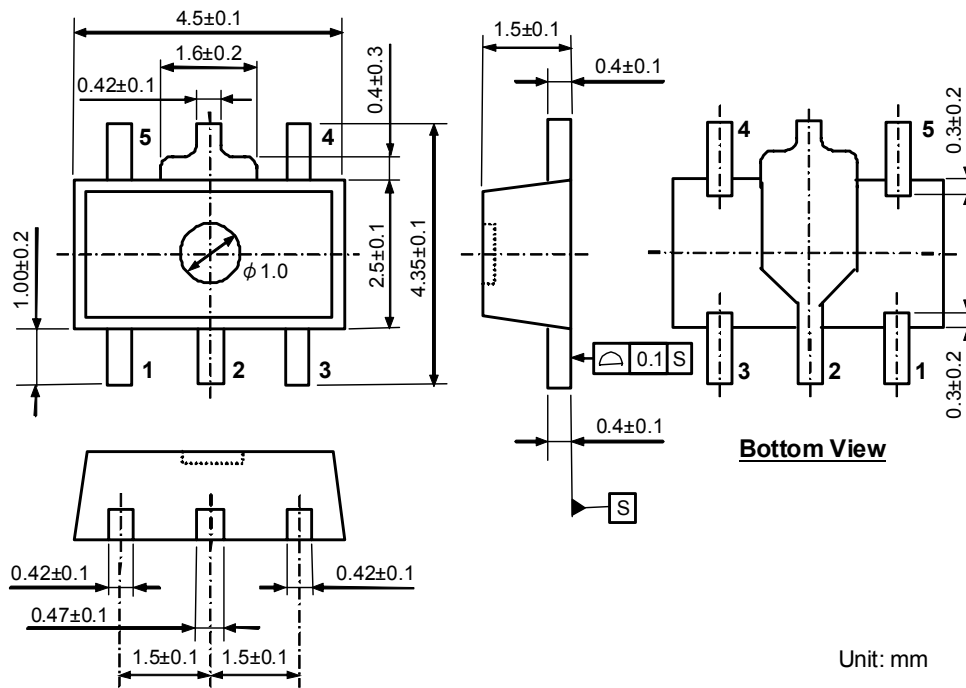

Unit: mm

**MARK SPECIFICATION (SOT-89-5)**

①②③④: Product Code ... Refer to R1514H MARK SPECIFICATION TABLE (SOT-89-5)

⑤⑥: Lot Number ... Alphanumeric Serial Number

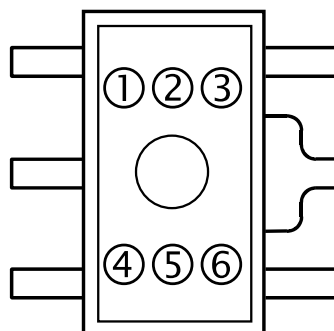

---

**R1514x-Y**NO. EA-346-140319

---

**R1514H MARK SPECIFICATION TABLE (SOT-89-5)**

Product Name	①②③④	V <sub>SET</sub>
R1514H025B	M 0 2 5	2.5 V
R1514H028B	M 0 2 8	2.8 V
R1514H030B	M 0 3 0	3.0 V
R1514H033B	M 0 3 3	3.3 V
R1514H034B	M 0 3 4	3.4 V
R1514H050B	M 0 5 0	5.0 V
R1514H060B	M 0 6 0	6.0 V
R1514H080B	M 0 8 0	8.0 V
R1514H085B	M 0 8 5	8.5 V
R1514H090B	M 0 9 0	9.0 V
R1514H120B	M 1 2 0	12.0 V

### POWER DISSIPATION (HSOP-6J)

Power Dissipation ( $P_D$ ) depends on conditions of mounting on board. This specification is based on the measurement at the condition below:

#### Measurement Conditions

	Ultra High Wattage Land Pattern	Standard Land Pattern
Environment	Mounting on Board (Wind velocity = 0 m/s)	Mounting on Board (Wind velocity = 0 m/s)
Board Material	Glass cloth epoxy plastic (4 Layers)	Glass cloth epoxy plastic (2 Layers)
Board Dimensions	76.2 mm × 114.3 mm × 0.8 mm	50 mm × 50 mm × 1.6 mm
Copper Ratio	96%	50%
Through-hole	φ0.3 mm × 28 pcs	φ0.5 mm × 24 pcs

#### Measurement Result

( $T_a = 25^\circ\text{C}$ ,  $T_{j\text{max}} = 125^\circ\text{C}$ )

	Ultra High Wattage Land Pattern	Standard Land Pattern	Free Air
Power Dissipation	2700 mW	1700 mW	540 mW
Thermal Resistance	37°C/W	59°C/W	185°C/W

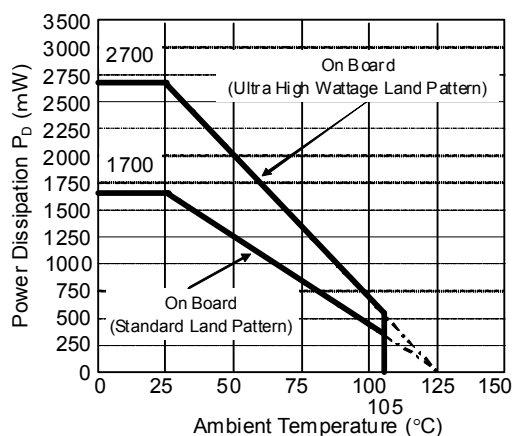

Power Dissipation

#### Power Dissipation vs. Ambience Temperature (HSOP-6J)

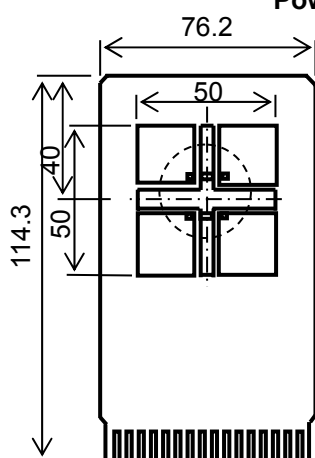

Ultra High Wattage Land Pattern  
IC Mount Area (Unit: mm)

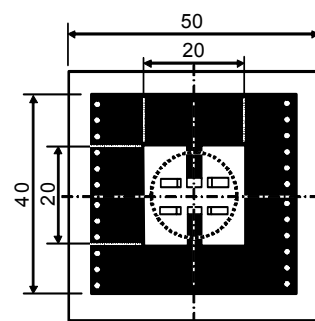

Standard

Measurement Board Pattern  
IC Mount Area (Unit: mm)

#### Measurement Board Pattern (HSOP-6J)

**R1514x-Y**

NO. EA-346-140319

**PACKAGE DIMENSIONS (HSOP-6J)**

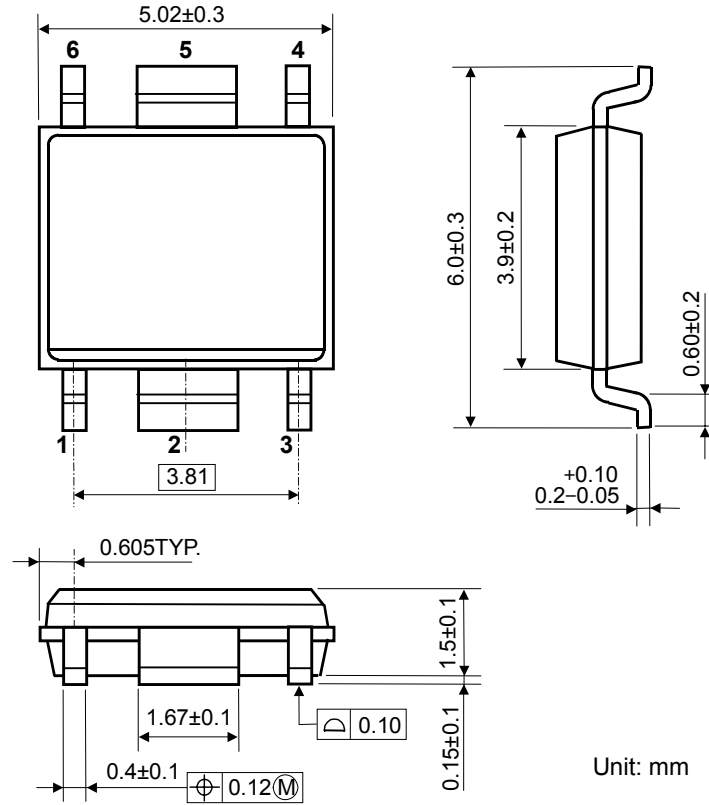

**MARK SPECIFICATION (HSOP-6J)**

- ①②③④: Product Code ... **Refer to R1514S MARK SPECIFICATION TABLE (HSOP-6J)**
- ⑤⑥: Lot Number ... Alphanumeric Serial Number

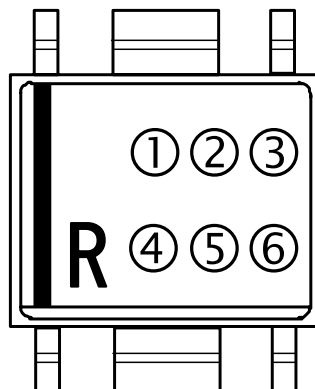

**R1514S MARK SPECIFICATION TABLE (HSOP-6J)**

<b>Product Name</b>	<b>①②③④</b>	<b>V<sub>SET</sub></b>
R1514S025B	E 0 2 5	2.5 V
R1514S028B	E 0 2 8	2.8 V
R1514S030B	E 0 3 0	3.0 V
R1514S033B	E 0 3 3	3.3 V
R1514S034B	E 0 3 4	3.4 V
R1514S050B	E 0 5 0	5.0 V
R1514S060B	E 0 6 0	6.0 V
R1514S080B	E 0 8 0	8.0 V
R1514S085B	E 0 8 5	8.5 V
R1514S090B	E 0 9 0	9.0 V
R1514S120B	E 1 2 0	12.0 V

**TEST CIRCUITS**

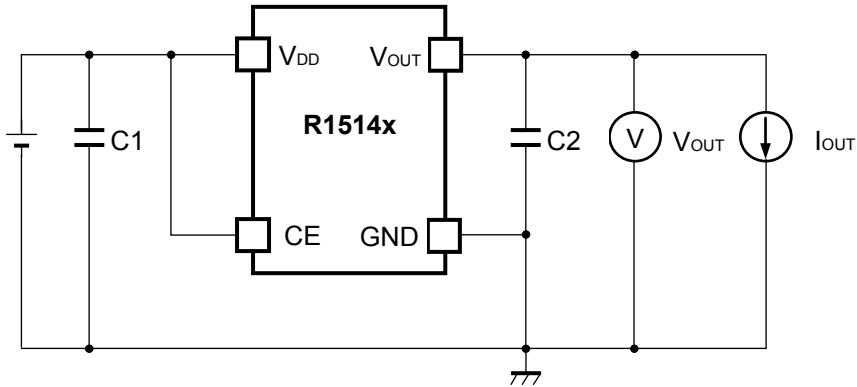

C1 = Ceramic 0.1  $\mu$ F  
C2 = Ceramic 0.1  $\mu$ F

**Basic Test Circuit**

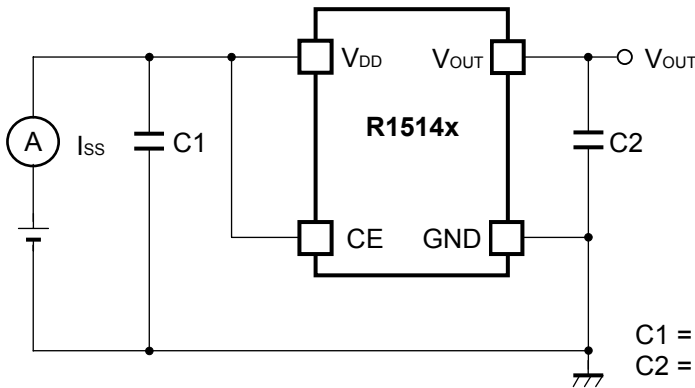

C1 = Ceramic 0.1  $\mu$ F  
C2 = Ceramic 0.1  $\mu$ F

**Test Circuit for Supply Current**

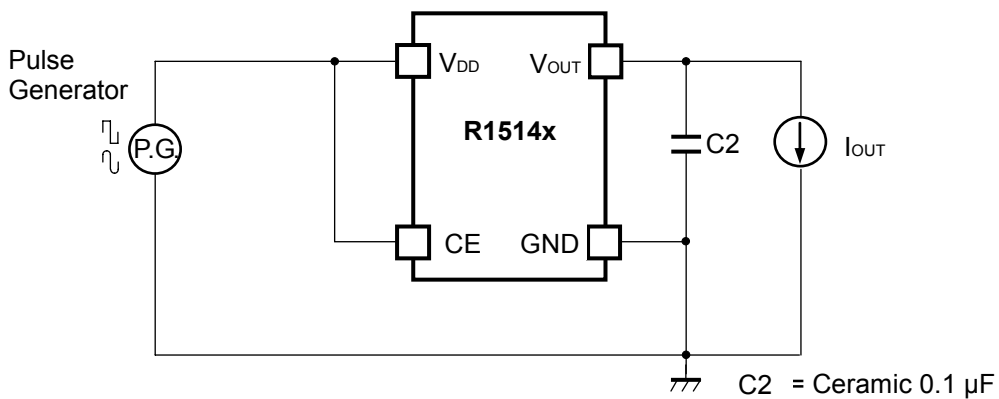

C2 = Ceramic 0.1  $\mu$ F

**Test Circuit for Line Transient Response**

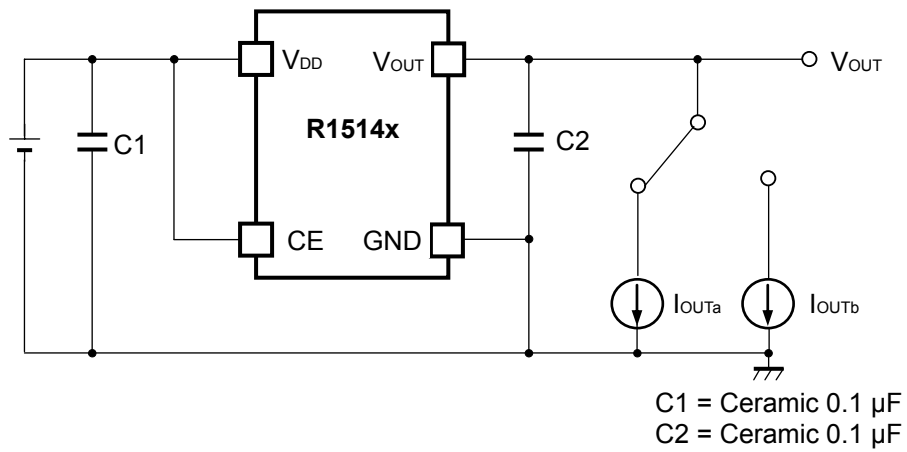

**Test Circuit for Load Transient Response**

## TYPICAL CHARACTERISTICS

Note: Typical Characteristics are intended to be used as reference data; they are not guaranteed.

### 1) Output Voltage vs. Output Current (Ta = 25°C)

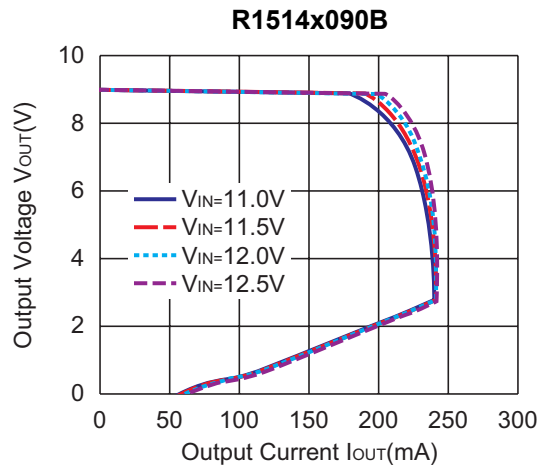
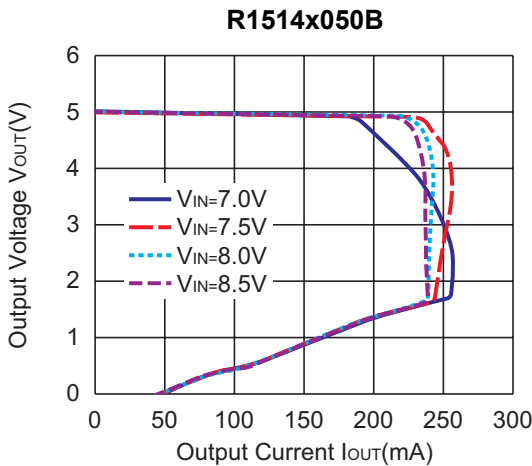
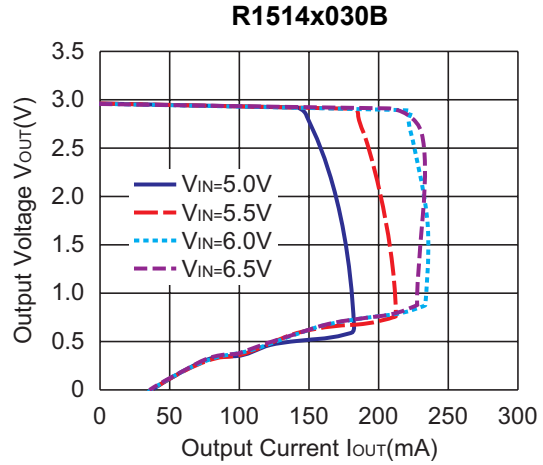
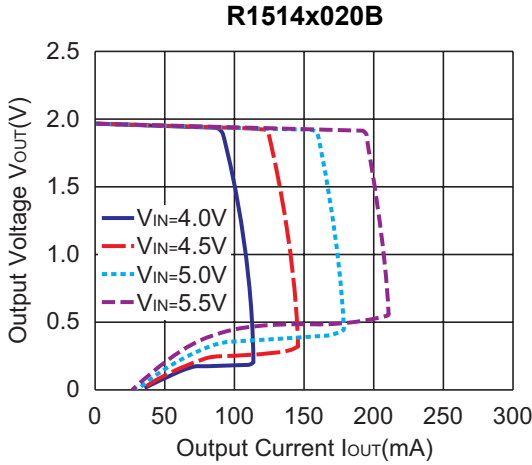

### 2) Output Voltage vs. Input Voltage (Ta = 25°C)

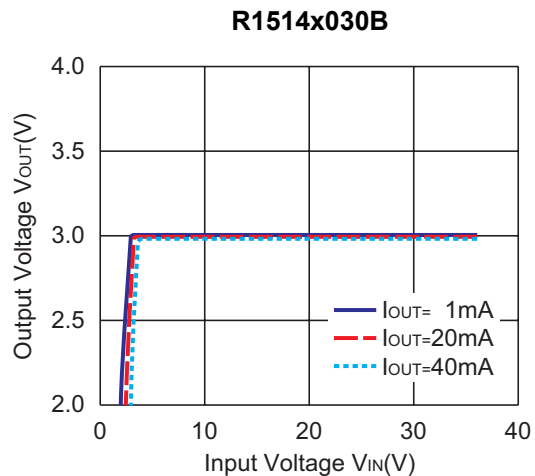
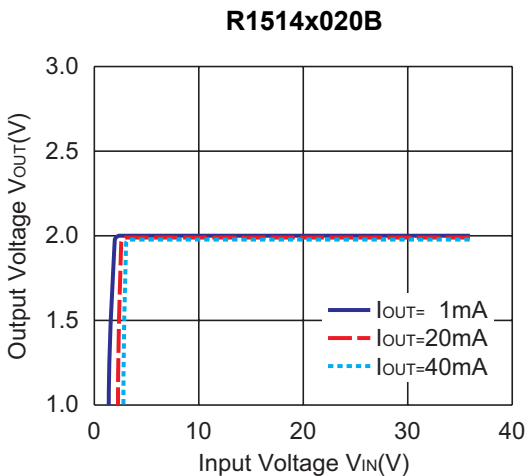



R1514x050B

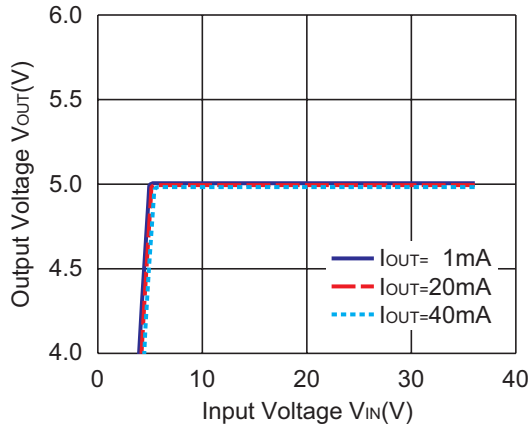

R1514x090B

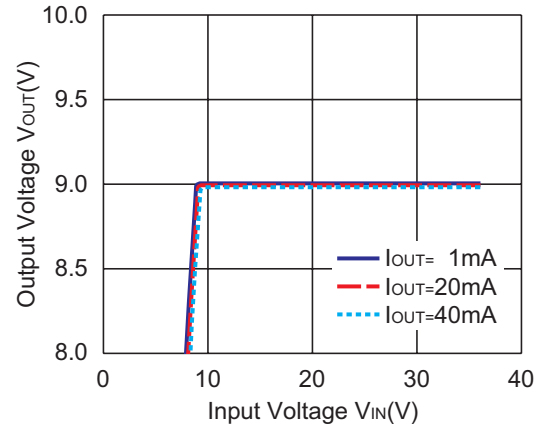

3) Dropout Voltage vs. Output Current

R1514x020B

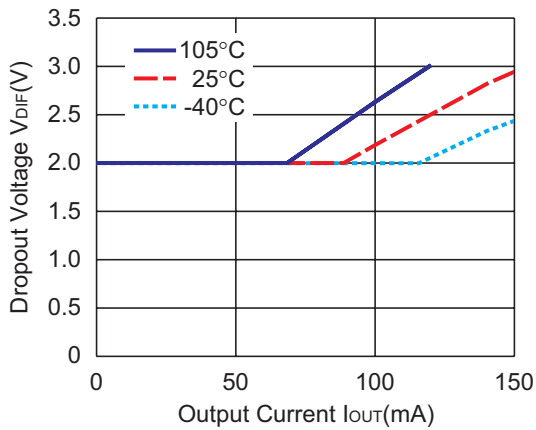

R1514x030B

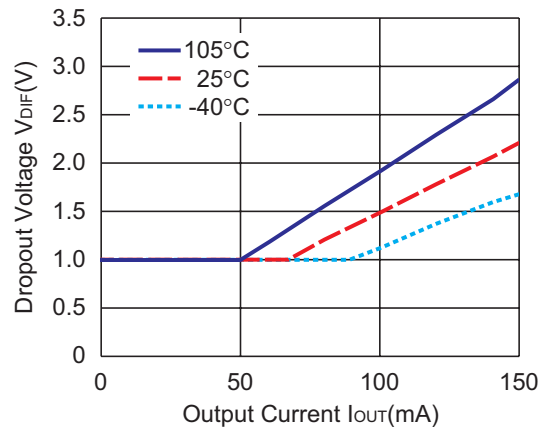

R1514x050B

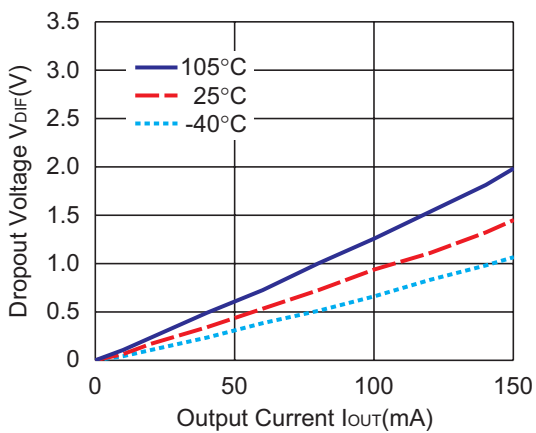

R1514x090B

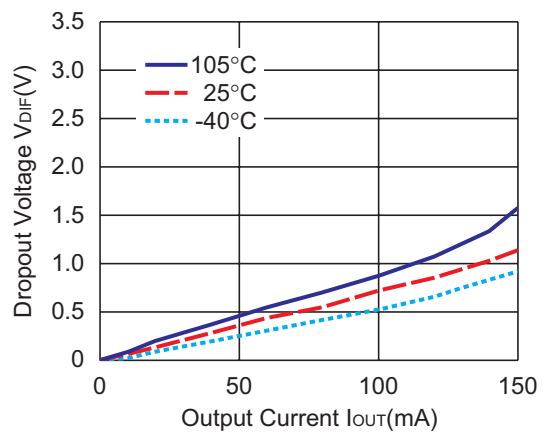

# R1514x-Y

NO. EA-346-140319

## 4) Output Voltage vs. Temperature

### R1514x020B

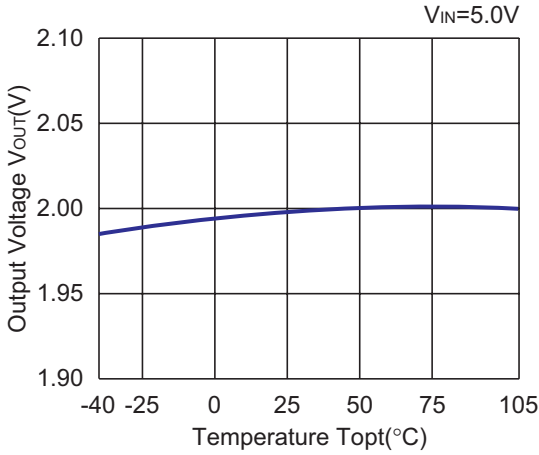

### R1514x030B

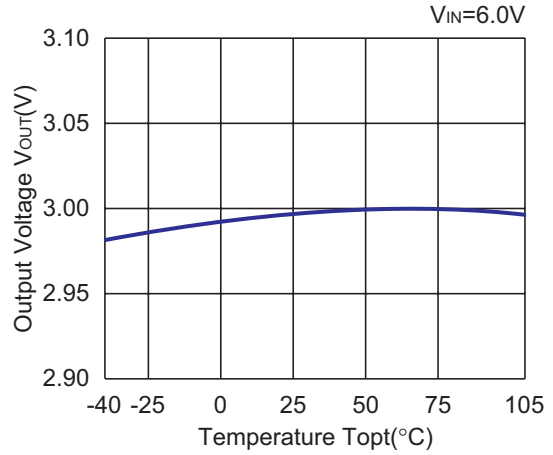

### R1514x050B

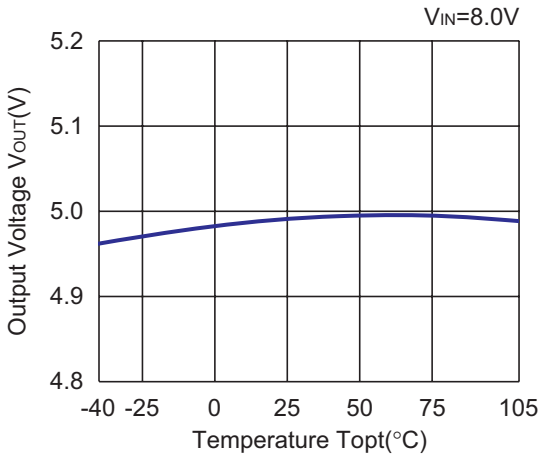

### R1514x090B

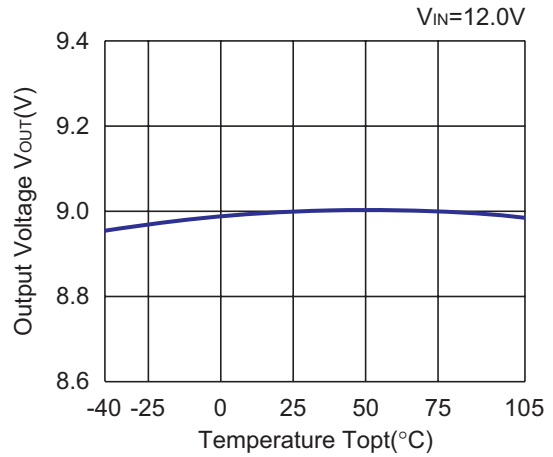

## 5) Supply Current vs. Input Voltage (Ta = 25°C)

### R1514x020B

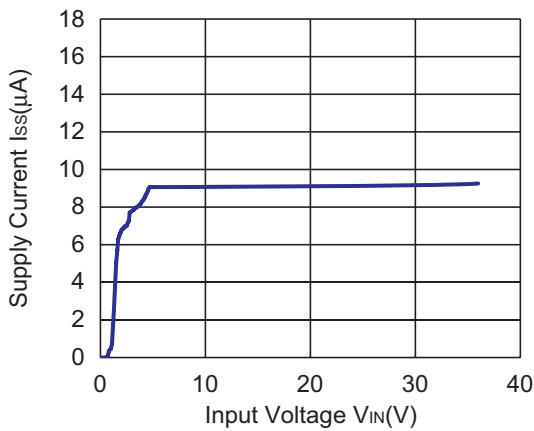

### R1514x030B

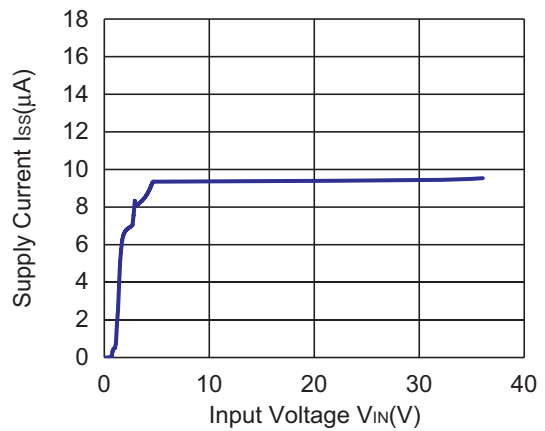

R1514x050B

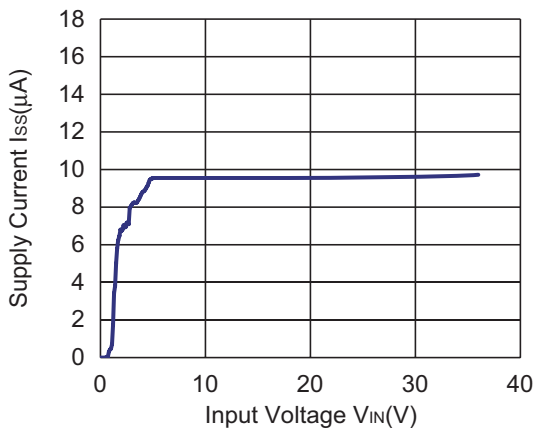

R1514x090B

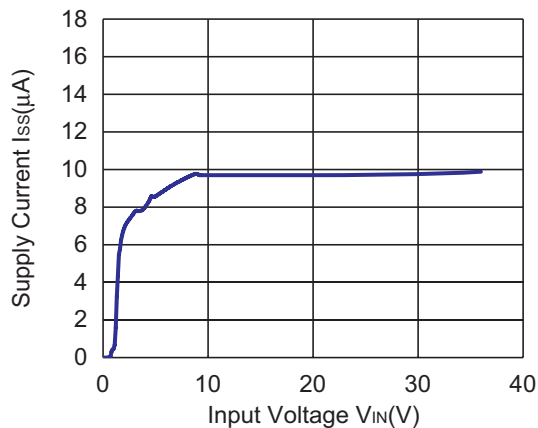

6) Supply Current vs. Temperature

R1514x020B

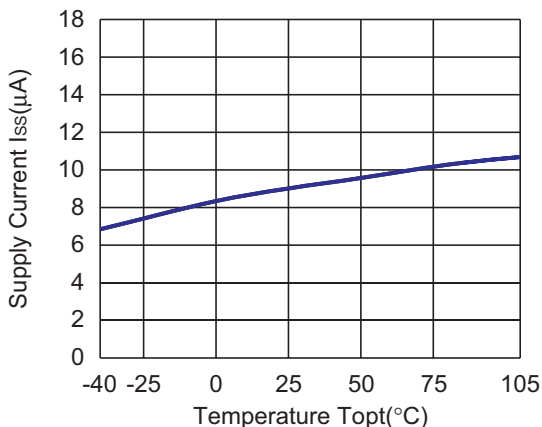

R1514x030B

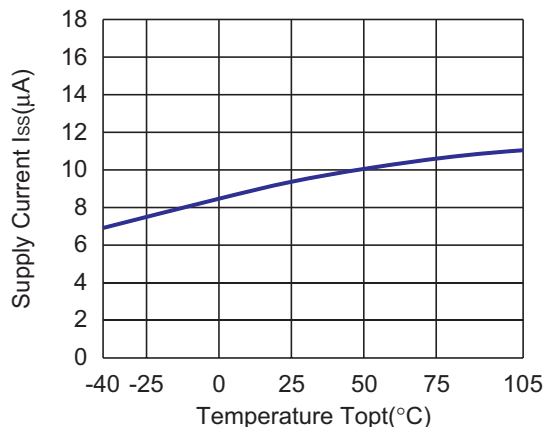

R1514x050B

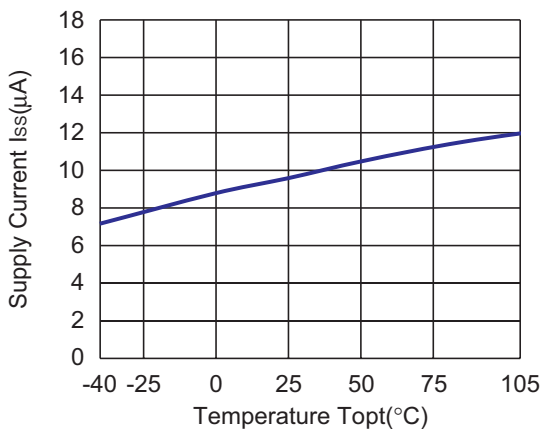

R1514x090B

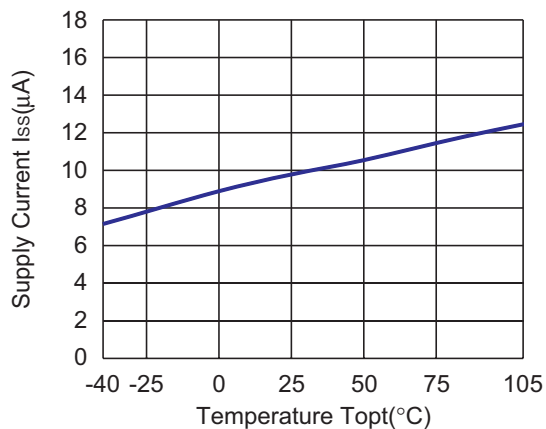

# R1514x-Y

NO. EA-346-140319

## 7) Input Transient Response ( $I_{OUT} = 1 \text{ mA}$ , $t_r = t_f = 50 \mu\text{s}$ , $C_2 = \text{Ceramic } 0.1 \mu\text{F}$ , $T_a = 25^\circ\text{C}$ )

### R1514x020B

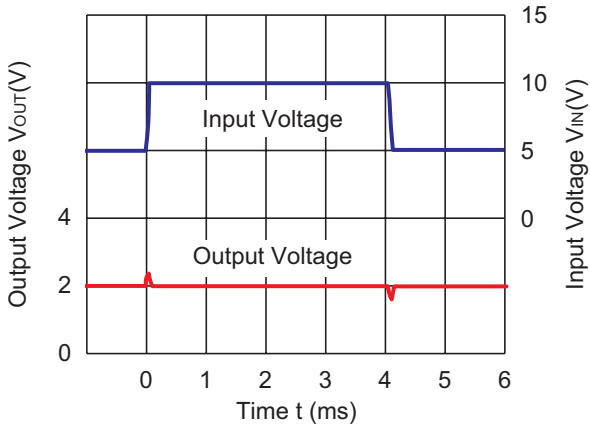

### R1514x030B

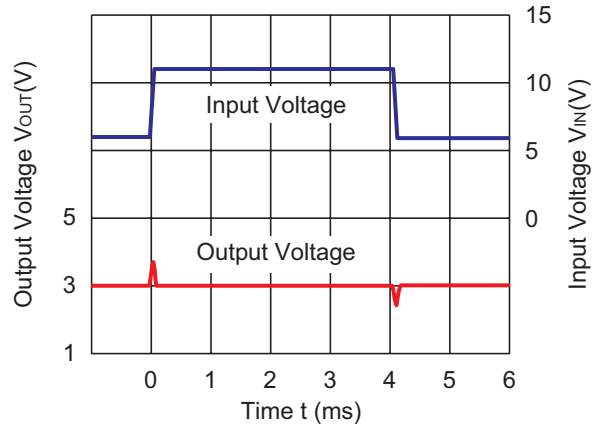

### R1514x050B

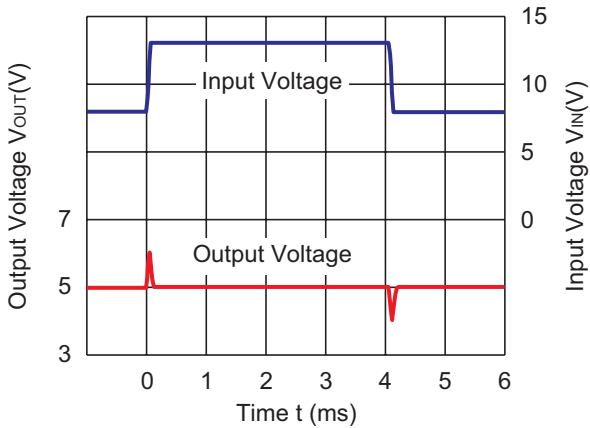

### R1514x090B

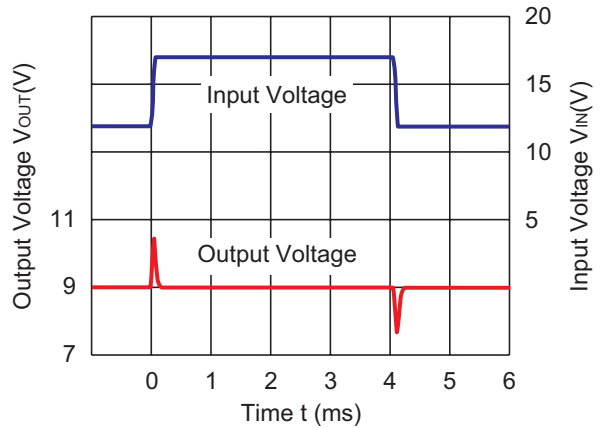

## 8) Load Transient Response ( $C_2 = \text{Ceramic } 0.1 \mu\text{F}$ , $T_a = 25^\circ\text{C}$ )

### R1514x020B

$V_{IN} = 5.0\text{V}$   
 $t_r = t_f = 50\mu\text{s}$

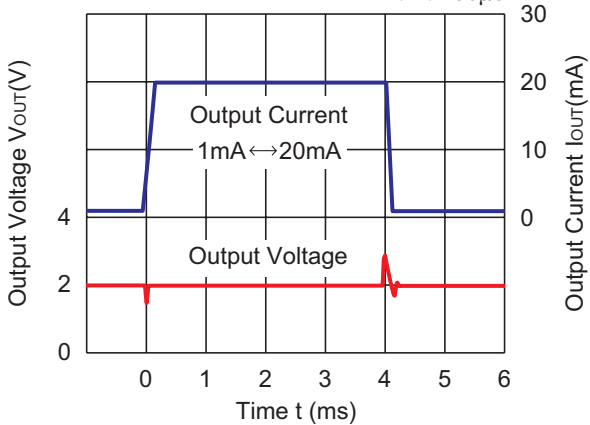

### R1514x030B

$V_{IN} = 6.0\text{V}$   
 $t_r = t_f = 50\mu\text{s}$

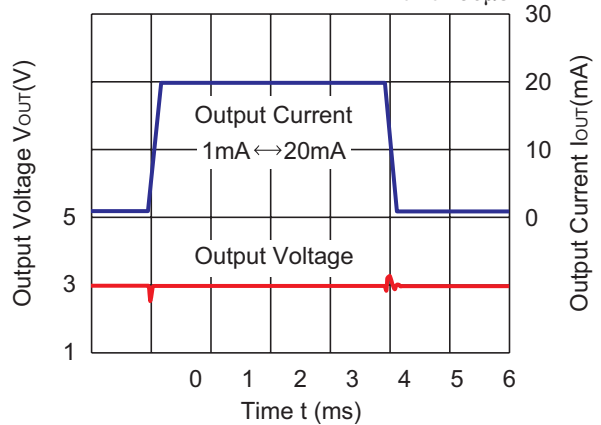

R1514x050B

$V_{IN}=8.0V$   
 $tr=tf=50\mu s$

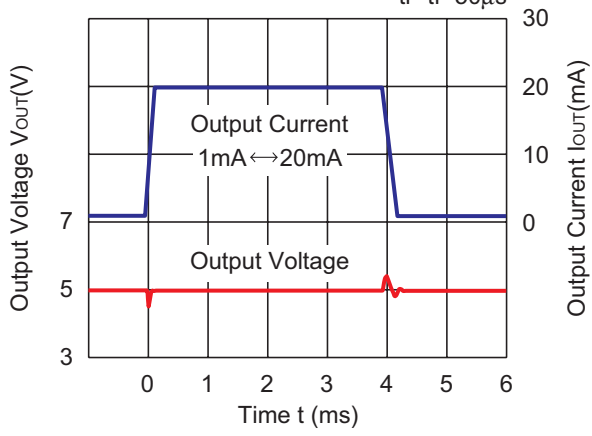

R1514x090B

$V_{IN}=12.0V$   
 $tr=tf=50\mu s$

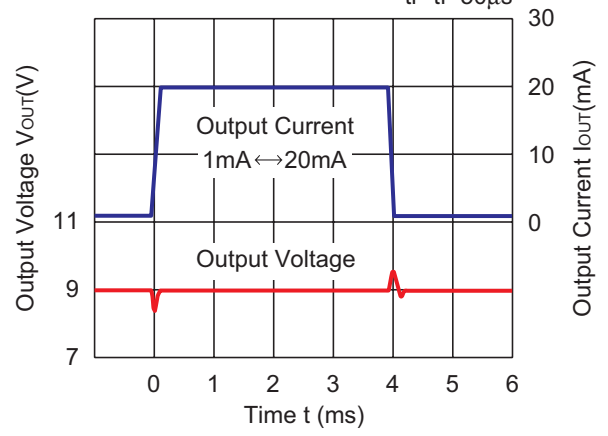



1. The products and the product specifications described in this document are subject to change or discontinuation of production without notice for reasons such as improvement. Therefore, before deciding to use the products, please refer to Ricoh sales representatives for the latest information thereon.
2. The materials in this document may not be copied or otherwise reproduced in whole or in part without prior written consent of Ricoh.
3. Please be sure to take any necessary formalities under relevant laws or regulations before exporting or otherwise taking out of your country the products or the technical information described herein.
4. The technical information described in this document shows typical characteristics of and example application circuits for the products. The release of such information is not to be construed as a warranty of or a grant of license under Ricoh's or any third party's intellectual property rights or any other rights.
5. The products listed in this document are intended and designed for use as general electronic components in standard applications (office equipment, telecommunication equipment, measuring instruments, consumer electronic products, amusement equipment etc.). Those customers intending to use a product in an application requiring extreme quality and reliability, for example, in a highly specific application where the failure or misoperation of the product could result in human injury or death (aircraft, spacevehicle, nuclear reactor control system, traffic control system, automotive and transportation equipment, combustion equipment, safety devices, life support system etc.) should first contact us.
6. We are making our continuous effort to improve the quality and reliability of our products, but semiconductor products are likely to fail with certain probability. In order to prevent any injury to persons or damages to property resulting from such failure, customers should be careful enough to incorporate safety measures in their design, such as redundancy feature, fire containment feature and fail-safe feature. We do not assume any liability or responsibility for any loss or damage arising from misuse or inappropriate use of the products.
7. Anti-radiation design is not implemented in the products described in this document.
8. The X-ray exposure can influence functions and characteristics of the products. Confirm the product functions and characteristics in the evaluation stage.
9. WLCSP products should be used in light shielded environments. The light exposure can influence functions and characteristics of the products under operation or storage.
10. There can be variation in the marking when different AOI (Automated Optical Inspection) equipment is used. In the case of recognizing the marking characteristic with AOI, please contact Ricoh sales or our distributor before attempting to use AOI.
11. Please contact Ricoh sales representatives should you have any questions or comments concerning the products or the technical information.



**Ricoh is committed to reducing the environmental loading materials in electrical devices with a view to contributing to the protection of human health and the environment.**

Ricoh has been providing RoHS compliant products since April 1, 2006 and Halogen-free products since April 1, 2012.

**RICOH** RICOH ELECTRONIC DEVICES CO., LTD.

<https://www.e-devices.ricoh.co.jp/en/>

#### Sales & Support Offices

##### **Ricoh Electronic Devices Co., Ltd.**

##### **Shin-Yokohama Office (International Sales)**

2-3, Shin-Yokohama 3-chome, Kohoku-ku, Yokohama-shi, Kanagawa, 222-8530, Japan  
Phone: +81-50-3814-7687 Fax: +81-45-474-0074

##### **Ricoh Americas Holdings, Inc.**

675 Campbell Technology Parkway, Suite 200 Campbell, CA 95008, U.S.A.  
Phone: +1-408-610-3105

##### **Ricoh Europe (Netherlands) B.V.**

##### **Semiconductor Support Centre**

Prof. W.H. Keesomlaan 1, 1183 DJ Amstelveen, The Netherlands  
Phone: +31-20-5474-309

##### **Ricoh International B.V. - German Branch**

##### **Semiconductor Sales and Support Centre**

Oberrather Strasse 6, 40472 Düsseldorf, Germany  
Phone: +49-211-6546-0

##### **Ricoh Electronic Devices Korea Co., Ltd.**

3F, Haesung Bldg, 504, Teheran-ro, Gangnam-gu, Seoul, 135-725, Korea  
Phone: +82-2-2135-5700 Fax: +82-2-2051-5713

##### **Ricoh Electronic Devices Shanghai Co., Ltd.**

Room 403, No.2 Building, No.690 Bibo Road, Pu Dong New District, Shanghai 201203,  
People's Republic of China  
Phone: +86-21-5027-3200 Fax: +86-21-5027-3299

##### **Ricoh Electronic Devices Shanghai Co., Ltd.**

##### **Shenzhen Branch**

1205, Block D (Jinlong Building), Kingkey 100, Hongbao Road, Luohu District,  
Shenzhen, China  
Phone: +86-755-8348-7600 Ext 225

##### **Ricoh Electronic Devices Co., Ltd.**

##### **Taipei office**

Room 109, 10F-1, No.51, Hengyang Rd., Taipei City, Taiwan (R.O.C.)  
Phone: +886-2-2313-1621/1622 Fax: +886-2-2313-1623

# Mouser Electronics

Authorized Distributor

Click to View Pricing, Inventory, Delivery & Lifecycle Information:

[Ricoh Electronics:](#)

[R1514H120B-T1-YE](#)

Компания «Океан Электроники» предлагает заключение долгосрочных отношений при поставках импортных электронных компонентов на взаимовыгодных условиях!

Наши преимущества:

- Поставка оригинальных импортных электронных компонентов напрямую с производств Америки, Европы и Азии, а так же с крупнейших складов мира;
- Широкая линейка поставок активных и пассивных импортных электронных компонентов (более 30 млн. наименований);
- Поставка сложных, дефицитных, либо снятых с производства позиций;
- Оперативные сроки поставки под заказ (от 5 рабочих дней);
- Экспресс доставка в любую точку России;
- Помощь Конструкторского Отдела и консультации квалифицированных инженеров;
- Техническая поддержка проекта, помощь в подборе аналогов, поставка прототипов;
- Поставка электронных компонентов под контролем ВП;
- Система менеджмента качества сертифицирована по Международному стандарту ISO 9001;
- При необходимости вся продукция военного и аэрокосмического назначения проходит испытания и сертификацию в лаборатории (по согласованию с заказчиком);
- Поставка специализированных компонентов военного и аэрокосмического уровня качества (Xilinx, Altera, Analog Devices, Intersil, Interpoint, Microsemi, Actel, Aeroflex, Peregrine, VPT, Syfer, Eurofarad, Texas Instruments, MS Kennedy, Miteq, Cobham, E2V, MA-COM, Hittite, Mini-Circuits, General Dynamics и др.);

Компания «Океан Электроники» является официальным дистрибьютором и эксклюзивным представителем в России одного из крупнейших производителей разъемов военного и аэрокосмического назначения «JONHON», а так же официальным дистрибьютором и эксклюзивным представителем в России производителя высокотехнологичных и надежных решений для передачи СВЧ сигналов «FORSTAR».



## JONHON

«JONHON» (основан в 1970 г.)

Разъемы специального, военного и аэрокосмического назначения:

(Применяются в военной, авиационной, аэрокосмической, морской, железнодорожной, горно- и нефтедобывающей отраслях промышленности)

«FORSTAR» (основан в 1998 г.)

ВЧ соединители, коаксиальные кабели, кабельные сборки и микроволновые компоненты:

(Применяются в телекоммуникациях гражданского и специального назначения, в средствах связи, РЛС, а так же военной, авиационной и аэрокосмической отраслях промышленности).



Телефон: 8 (812) 309-75-97 (многоканальный)

Факс: 8 (812) 320-03-32

Электронная почта: [ocean@oceanchips.ru](mailto:ocean@oceanchips.ru)

Web: <http://oceanchips.ru/>

Адрес: 198099, г. Санкт-Петербург, ул. Калинина, д. 2, корп. 4, лит. А