

### FEATURES

- Allows Safe Board Insertion and Removal from a Live Backplane
- System Reset and Power Good Control Outputs
- Programmable Electronic Circuit Breaker
- User Programmable Supply Voltage Power-Up Rate
- High Side Driver for Two External N-Channels
- Controls Supply Voltages from 3V to 12V
- Connection Inputs Detect Board Insertion or Removal
- Undervoltage Lockout
- Power-On Reset Input

### APPLICATIONS

- Hot Board Insertion
- Electronic Circuit Breaker

### DESCRIPTION

The LTC<sup>®</sup>1421/LTC1421-2.5 are Hot Swap<sup>™</sup> controllers that allow a board to be safely inserted and removed from a live backplane. Using external N-channel pass transistors, the board supply voltages can be ramped up at a programmable rate. Two high side switch drivers control the N-channel gates for supply voltages ranging from 3V to 12V.

A programmable electronic circuit breaker protects against shorts. Warning signals indicate that the circuit breaker has tripped, a power failure has occurred or that the switch drivers are turned off. The reset output can be used to generate a system reset when the power cycles or a fault occurs. The two connect inputs can be used with staggered connector pins to indicate board insertion or removal. The power-on reset input can be used to cycle the board power or clear the circuit breaker.

The trip point of the ground sense comparator is set at 0.1V for LTC1421 and 2.5V for LTC1421-2.5.

The LTC1421/LTC1421-2.5 are available in 24-pin SO and SSOP packages.

LT, LTC and LT are registered trademarks of Linear Technology Corporation. Hot Swap is a trademark of Linear Technology Corporation.

### TYPICAL APPLICATION

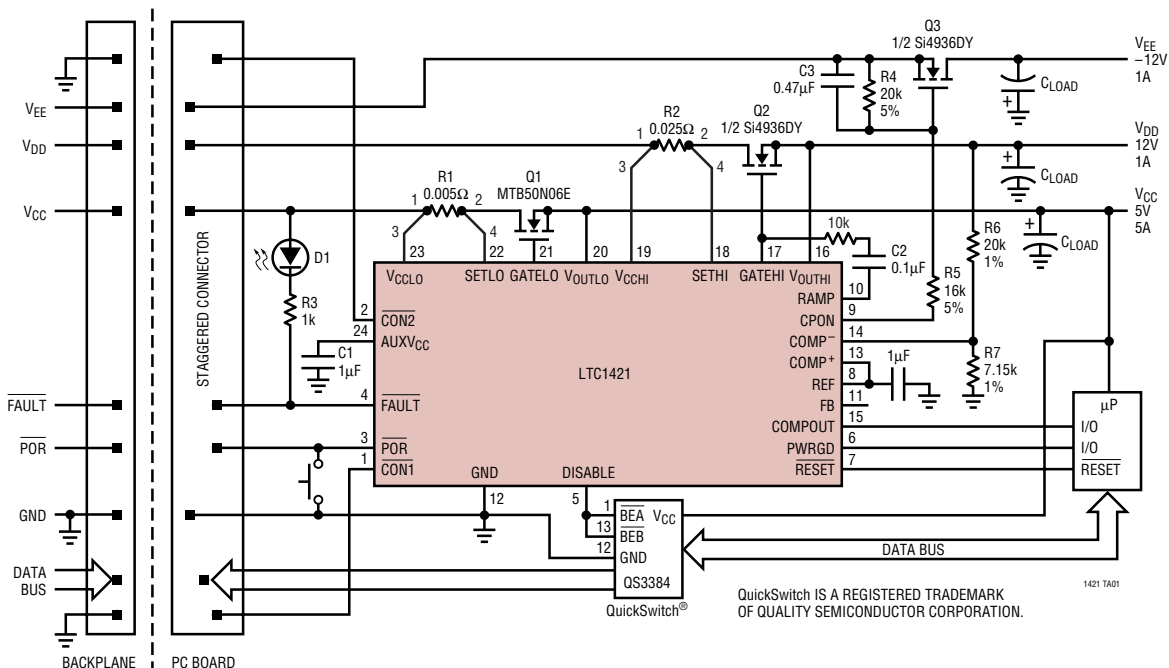

# LTC1421/LTC1421-2.5

## ABSOLUTE MAXIMUM RATINGS

(Note 1)

Supply Voltage ( $V_{CCLO}$ , $V_{CCHI}$ , $AUXV_{CC}$ ) .....	13.2V
Input Voltage (Analog Pins) .....	- 0.3V to ( $V_{CCHI} + 0.3V$ )
Input Voltage (Digital Pins) .....	- 0.3V to 13.2V
Output Voltage (Digital Pins) ..	- 0.3V to ( $V_{CCLO} + 0.3V$ )
Output Voltage (CPON) .....	- 13.2V to ( $V_{CCLO} + 0.3V$ )
Output Voltage ( $V_{OUTLO}$ , $V_{OUTH}$ ) .....	- 0.3V to 13.2V
Output Voltage (GATELO, GATEHI) .....	- 0.3V to 20V
Operating Temperature Range	
LTC1421C .....	0°C to 70°C
LTC1421I .....	-40°C to 85°C
Storage Temperature Range .....	-65°C to 150°C
Lead Temperature (Soldering, 10 sec) .....	300°C

## PACKAGE/ORDER INFORMATION

TOP VIEW		ORDER PART NUMBER
CON1	1	LTC1421CG LTC1421CSW LTC1421CG-2.5 LTC1421CSW-2.5 LTC1421IG LTC1421ISW LTC1421IG-2.5 LTC1421ISW-2.5
CON2	2	
POR	3	
FAULT	4	
DISABLE	5	
PWRGD	6	
RESET	7	
REF	8	
CPON	9	
RAMP	10	
FB	11	
GND	12	
	13	COMP+
	14	COMP-
	15	COMPOUT
	16	V <sub>OUTH</sub>
	17	GATEHI
	18	SETHI
	19	V <sub>CCHI</sub>
	20	V <sub>OUTLO</sub>
	21	GATELO
	22	SETLO
	23	V <sub>CCLO</sub>
	24	AUXV <sub>CC</sub>

G PACKAGE      SW PACKAGE  
24-LEAD PLASTIC SSOP    24-LEAD PLASTIC SO

$T_{JMAX} = 125^{\circ}C$ ,  $\theta_{JA} = 100^{\circ}C/W$  (G)  
 $T_{JMAX} = 125^{\circ}C$ ,  $\theta_{JA} = 85^{\circ}C/W$  (SW)

Consult factory for parts specified with wider operating temperature ranges.

## ELECTRICAL CHARACTERISTICS

The ● denotes specifications which apply over the full operating temperature range, otherwise specifications are at  $T_A = 25^{\circ}C$ .  $V_{CCHI} = 12V$ ,  $V_{CCLO} = 5V$  unless otherwise noted (Note 2).

SYMBOL	PARAMETER	CONDITIONS	MIN	TYP	MAX	UNITS	
<b>DC Characteristics</b>							
$I_{CCLO}$	$V_{CCLO}$ Supply Current	$\overline{CON1} = \overline{CON2} = GND$ , $\overline{POR} = V_{CCLO}$	●	1.5	3	mA	
$I_{CCHI}$	$V_{CCHI}$ Supply Current	$\overline{CON1} = \overline{CON2} = GND$ , $\overline{POR} = V_{CCLO}$	●	0.6	1	mA	
$V_{LKO}$	Undervoltage Lockout	$V_{CCLO}$ and $V_{CCHI}$		2.28	2.45	2.60	V
$V_{LKH}$	Undervoltage Lockout Hysteresis	$V_{CCLO}$ and $V_{CCHI}$		100		mV	
$V_{REF}$	Reference Output Voltage	No Load	●	1.220	1.232	1.244	V
$\Delta V_{LNR}$	Reference Line Regulation	$3V \leq V_{CCLO} \leq 12V$ , No Load	●	4	8	mV	
$\Delta V_{LDR}$	Reference Load Regulation	$I_O = 0mA$ to $-5mA$ , Sourcing Only	●	1	3	mV	
$I_{RSC}$	Reference Short-Circuit Current	$V_{REF} = 0V$		-45		mA	
$V_{COF}$	Comparator Offset Voltage	$0V \leq V_{CM} \leq (V_{CCLO} - 1.3V)$	●		±10	mV	
$V_{CPSR}$	Comparator Power Supply Rejection	$0V \leq V_{CM} \leq (V_{CCLO} - 1.3V)$ , $3V \leq V_{CCLO} \leq 12V$	●		1	mV/V	
$V_{CHST}$	Comparator Hysteresis	$0V \leq V_{CM} \leq (V_{CCLO} - 1.3V)$		7		mV	
$V_{RST}$	Reset Voltage Threshold ( $V_{OUTLO}$ )	FB = $V_{OUTLO}$	●	2.80	2.90	3.00	V
		FB = Floating	●	4.50	4.65	4.75	V
		FB = GND	●	5.75	5.88	6.01	V
$V_{RHST}$	Reset Threshold Hysteresis ( $V_{OUTLO}$ )	FB = $V_{OUTLO}$		7		mV	
		FB = Floating		12		mV	
		FB = GND		15		mV	
$R_{FB}$	FB Pin Input Resistance	$0V \leq V_{FB} \leq V_{CCLO}$		95		k $\Omega$	
$V_{CB}$	Circuit Breaker Trip Voltage	$V_{CB} = (V_{CCLO} - V_{SETLO})$ or $V_{CB} = (V_{CCHI} - V_{SETHI})$	●	40	50	60	mV
$V_{TRIP}$	Output Voltage for Re-Power-Up	LTC1421 (Note 3)		0.1		V	
		LTC1421-2.5 (Note 4)		2.5		V	

## ELECTRICAL CHARACTERISTICS

The ● denotes specifications which apply over the full operating temperature range, otherwise specifications are at  $T_A = 25^\circ\text{C}$ .  $V_{\text{CCH1}} = 12\text{V}$ ,  $V_{\text{CCLO}} = 5\text{V}$  unless otherwise noted (Note 2).

SYMBOL	PARAMETER	CONDITIONS	MIN	TYP	MAX	UNITS	
$I_{\text{RAMP}}$	RAMP Pin Output Current	Charge Pump On, $V_{\text{RAMP}} = 0.4\text{V}$	● 11	17	23	$\mu\text{A}$	
$I_{\text{CP}}$	Charge Pump Output Current	Charge Pump On, $\text{GATEHI} = 0\text{V}$ $\text{GATELO} = 0\text{V}$		-600 -300		$\mu\text{A}$ $\mu\text{A}$	
$\Delta V_{\text{GATEHI}}$	GATEHI N-Channel Gate Drive	$V_{\text{GATEHI}} - V_{\text{OUTH1}}$			16	V	
$\Delta V_{\text{GATELO}}$	GATELO N-Channel Gate Drive	$V_{\text{GATELO}} - V_{\text{OUTLO}}$			16	V	
$V_{\text{AUXVCC}}$	Auxiliary $V_{\text{CC}}$ Output Voltage	$V_{\text{CCLO}} = 5\text{V}$ , Unloaded		4.5		V	
$V_{\text{IL}}$	Input Low Voltage	$\overline{\text{CON1}}$ , $\overline{\text{CON2}}$ , $\overline{\text{POR}}$	●		0.8	V	
$V_{\text{IH}}$	Input High Voltage	$\overline{\text{CON1}}$ , $\overline{\text{CON2}}$ , $\overline{\text{POR}}$	●	2		V	
$I_{\text{IN}}$	Input Current	$\overline{\text{CON1}}$ , $\overline{\text{CON2}}$ , $\overline{\text{POR}} = \text{GND}$	●	-30	-60	-90	$\mu\text{A}$
$V_{\text{OL}}$	Output Low Voltage	$\overline{\text{RESET}}$ , $\overline{\text{COMPOUT}}$ , $\overline{\text{PWRGD}}$ , $\overline{\text{DISABLE}}$ , $\overline{\text{FAULT}}$ , $I_{\text{O}} = 3\text{mA}$	●		0.4	V	
		CPON, $I_{\text{O}} = 3\text{mA}$	●		1.45	V	
$V_{\text{OH}}$	Output High Voltage	$\overline{\text{DISABLE}}$ , $I_{\text{O}} = -3\text{mA}$	●	4		V	
		CPON, $I_{\text{O}} = -1\text{mA}$	●	3.4		V	
$I_{\text{PU}}$	Logic Output Pull-Up Current	$\overline{\text{RESET}}$ , $\overline{\text{PWRGD}}$ , $\overline{\text{FAULT}} = \text{GND}$		-15		$\mu\text{A}$	

### AC CHARACTERISTICS

$t_1$	$\overline{\text{CON1}}$ or $\overline{\text{CON2}} \downarrow$ to CPON $\uparrow$	Figure 1, $C_L = 15\text{pF}$	●	15	20	30	ms
$t_2$	$\overline{\text{PWRGD}} \uparrow$ to $\overline{\text{RESET}} \uparrow$	Figure 1, $R_L = 10\text{k}$ to $V_{\text{CCLO}}$ , $C_L = 15\text{pF}$	●	160	200	240	ms
			●	140	200	280	ms
$t_3$	$\overline{\text{PWRGD}} \uparrow$ to $\overline{\text{DISABLE}} \downarrow$	Figure 1, $C_L = 15\text{pF}$	●	160	200	240	ms
			●	140	200	280	ms
$t_4$	$\overline{\text{POR}} \downarrow$ to CPON $\downarrow$	Figure 1, $C_L = 15\text{pF}$	●	15	20	30	ms
$t_5$	$\overline{\text{PWRGD}} \downarrow$ to $\overline{\text{RESET}} \downarrow$	Figure 1, $R_L = 10\text{k}$ to $V_{\text{CCLO}}$ , $C_L = 15\text{pF}$			32		$\mu\text{s}$
$t_6$	$\overline{\text{POR}} \uparrow$ to CPON $\uparrow$	Figure 1, $C_L = 15\text{pF}$			50		ns
$t_7$	$\overline{\text{CON1}}$ or $\overline{\text{CON2}} \uparrow$ to CPON $\downarrow$	Figure 1, $C_L = 15\text{pF}$			50		ns
$t_9$	Short-Circuit Detect to $\overline{\text{FAULT}} \downarrow$	Figure 1, $R_L = 10\text{k}$ to $V_{\text{CCLO}}$ , $C_L = 15\text{pF}$ $V_{\text{CCLO}} - \text{SETLO} = 0\text{mV}$ to $100\text{mV}$			20		$\mu\text{s}$
$t_{10}$	Short-Circuit Detect to CPON $\downarrow$	Figure 2, $C_L = 15\text{pF}$ $V_{\text{CCLO}} - \text{SETLO} = 0\text{mV}$ to $100\text{mV}$			20		$\mu\text{s}$
$t_{11}$	$\overline{\text{POR}} \uparrow$ to $\overline{\text{FAULT}} \uparrow$	Figure 2, $R_L = 10\text{k}$ to $V_{\text{CCLO}}$ , $C_L = 15\text{pF}$			20		ns
$t_{\text{CHL}}$	Comparator High to Low	$\text{COMP}^- = 1.232\text{V}$ , $10\text{mV}$ Overdrive $R_L = 10\text{k}$ to $V_{\text{CCLO}}$ , $C_L = 15\text{pF}$	●		0.25	0.5	$\mu\text{s}$
$t_{\text{CLH}}$	Comparator Low to High	$\text{COMP}^- = 1.232\text{V}$ , $10\text{mV}$ Overdrive $R_L = 10\text{k}$ to $V_{\text{CCLO}}$ , $C_L = 15\text{pF}$	●		1	1.5	$\mu\text{s}$

**Note 1:** Absolute Maximum Ratings are those values beyond which the life of a device may be impaired.

**Note 2:** All currents into device pins are positive; all currents out of device pins are negative. All voltages are reference to ground unless otherwise specified.

**Note 3:** After power-on reset, the  $V_{\text{OUTLO}}$  and  $V_{\text{OUTH1}}$  have to drop below the  $V_{\text{TRIP}}$  point before the charge pump is restarted.

**Note 4:** After power-on reset, the  $V_{\text{OUTLO}}$  has to drop below the  $V_{\text{TRIP}}$  point before the charge pump is restarted.

## TYPICAL PERFORMANCE CHARACTERISTICS

**Reference Voltage vs Temperature**

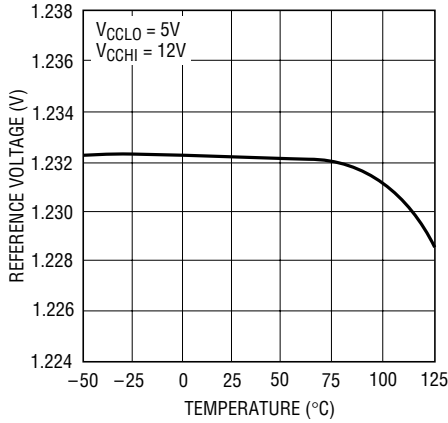

**Gate Voltage vs Temperature**

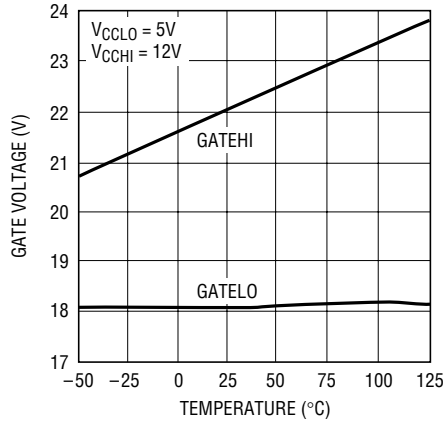

**Reference Voltage vs Source Current**

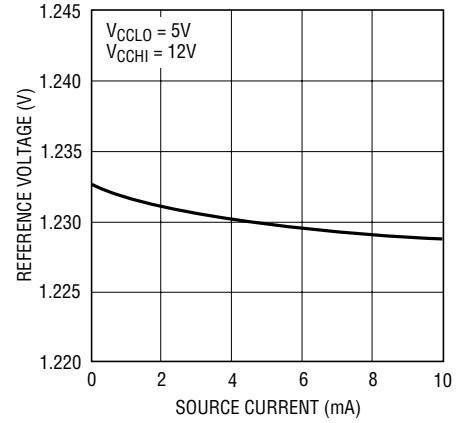

**GATELO Voltage vs VCCLO Voltage**

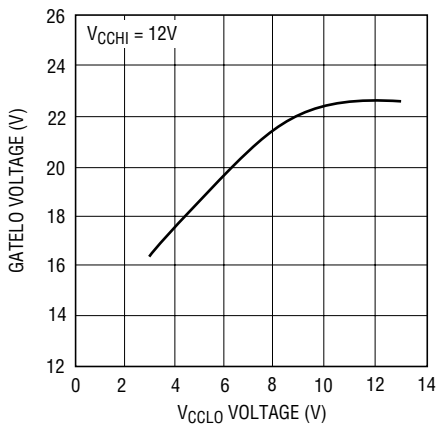

**GATEHI Voltage vs VCCHI Voltage**

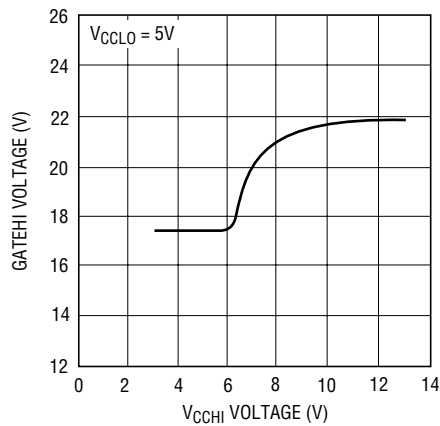

**ICCLO Supply Current vs Temperature**

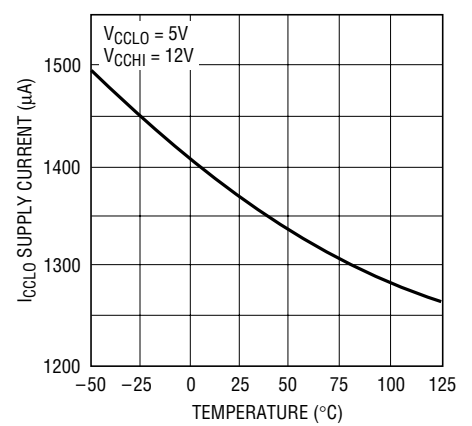

**ICCHI Supply Current vs Temperature**

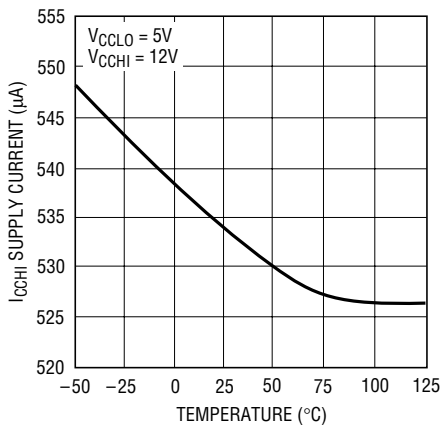

**VOL vs ISINK**

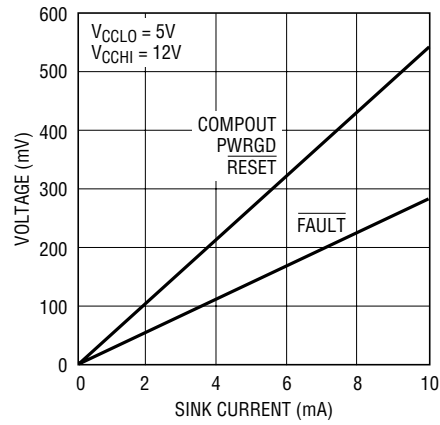

**CPON Voltage vs Sink Current (Charge Pump Off)**

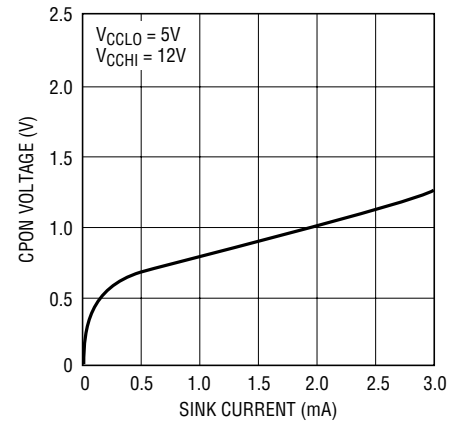

## TYPICAL PERFORMANCE CHARACTERISTICS

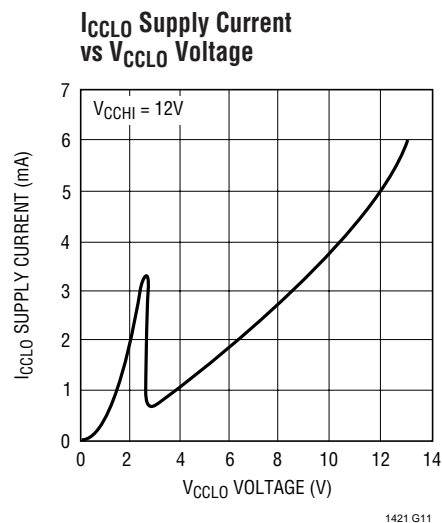
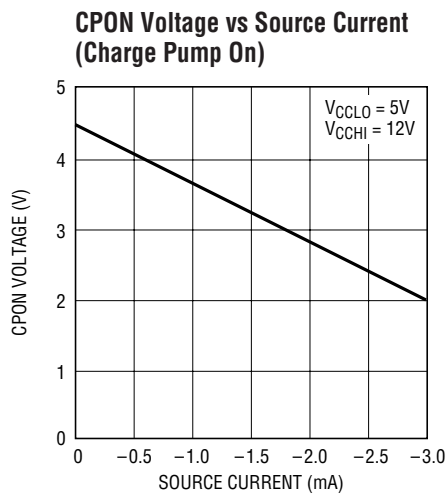

## PIN FUNCTIONS

**CON1 (Pin 1):** TTL Level Input with a Pull-Up to  $V_{CCLO}$ . Together with  $\overline{CON2}$ , it is used to indicate board connection. The pin must be tied to ground on the host side of the connector. When using staggered connector pins,  $\overline{CON1}$  and  $\overline{CON2}$  must be the shortest and must be placed at opposite corners of the connector. Board insertion is assumed after  $\overline{CON1}$  and  $\overline{CON2}$  are both held low for 20ms after power-up.

**CON2 (Pin 2):** TTL Level Input with a Pull-Up to  $V_{CCLO}$ . Together with  $\overline{CON1}$  it is used to indicate board connection.

**POR (Pin 3):** TTL Level Input with a Pull-Up to  $V_{CCLO}$ . When the pin is pulled low for at least 20ms, a hard reset is generated. Both  $V_{OUTLO}$  and  $V_{OUTH1}$  will turn off at a controlled rate. A power-up sequence will not start until the  $\overline{POR}$  pin is pulled high. If  $\overline{POR}$  is pulled high before  $V_{OUTLO}$  and  $V_{OUTH1}$  are fully discharged, a power-up sequence will not begin until the voltage at  $V_{OUTLO}$  and  $V_{OUTH1}$  are below  $V_{TRIP}$ . The electronic circuit breaker will be reset by pulling  $\overline{POR}$  low.

**FAULT (Pin 4):** Open Drain Output to GND with a Weak Pull-Up to  $V_{CCLO}$ . The pin is pulled low when an overcurrent fault is detected at  $V_{OUTLO}$  or  $V_{OUTH1}$ .

**DISABLE (Pin 5):** CMOS Output. The signal is used to disable the board's data bus during insertion or removal.

**PWRGD (Pin 6):** Open Drain Output to GND with a Weak Pull-Up to  $V_{CCLO}$ . The pin is pulled low immediately after  $V_{OUTLO}$  falls below its reset threshold voltage. The pin is pulled high immediately after  $V_{OUTLO}$  rises above its reset threshold voltage.

**RESET (Pin 7):** Open Drain Output to GND with a Weak Pull-Up to  $V_{CCLO}$ . The pin is pulled low when a reset condition is detected. A reset will be generated when any of the following conditions are met: Either  $\overline{CON1}$  or  $\overline{CON2}$  is high,  $\overline{POR}$  is pulled low,  $V_{CCLO}$  or  $V_{CCHI}$  are below their respective undervoltage lockout thresholds,  $\overline{PWRGD}$  goes low or an overcurrent fault is detected at  $V_{OUTLO}$  or  $V_{OUTH1}$ .  $\overline{RESET}$  will go high 200ms after  $\overline{PWRGD}$  goes high. On power failure,  $\overline{RESET}$  will go low 32 $\mu$ s after  $\overline{PWRGD}$  goes low.

**REF (Pin 8):** The Reference Voltage Output.  $V_{OUT} = 1.232V \pm 1\%$ . The reference can source up to 5mA of current. A 1 $\mu$ F bypass capacitor is recommended.

**CPON (Pin 9):** CMOS Output That Can Be Pulled Below Ground.  $\overline{CPON}$  is pulled high when the internal charge pumps for  $\overline{GATELO}$  and  $\overline{GATEHI}$  are turned on.  $\overline{CPON}$  is pulled low when the charge pumps are turned off. The pin can be used to control an external MOSFET for a -5V to -12V supply.

## PIN FUNCTIONS

**RAMP (Pin 10):** Analog Power-Up Ramp Control Pin. By connecting an external capacitor between the RAMP and GATEHI, a positive linear voltage ramp on GATEHI and GATELO is generated on power-up with a slope equal to  $20\mu\text{A}/C_{\text{RAMP}}$ . A 10k resistor in series with the capacitor enhances the ESD performance at the GATEHI pin.

**FB (Pin 11):** Analog Feedback Input. FB is used to set the reset threshold voltage on  $V_{\text{CCLO}}$ . For a 5V supply leave FB floating. For a 3.3V supply, short FB to  $V_{\text{CCLO}}$ .

**GND (Pin 12):** Ground

**COMP<sup>+</sup> (Pin 13):** Noninverting Comparator Input.

**COMP<sup>-</sup> (Pin 14):** Inverting Comparator Input.

**COMPOUT (Pin 15):** Open Drain Comparator Output.

**V<sub>OUTH</sub> (Pin 16):** High Supply Voltage Output. This must be the higher of the two supply voltage outputs.

**GATEHI (Pin 17):** The High Side Gate Drive for the High Supply N-Channel. An internal charge pump guarantees at least 6V of gate drive. The slope of the voltage rise at GATEHI is set by the external capacitor connected between GATEHI and RAMP. When the circuit breaker trips, GATEHI is immediately pulled to GND.

**SETHI (Pin 18):** The Circuit Breaker Set Pin for the High Supply. With a sense resistor placed in the supply path between  $V_{\text{CCHI}}$  and SETHI, the circuit breaker will trip when the voltage across the resistor exceeds 50mV for more than 20 $\mu\text{s}$ . To disable the circuit breaker,  $V_{\text{CCHI}}$  and SETHI should be shorted together.

**V<sub>CCHI</sub> (Pin 19):** The Positive Supply Input. This must be the higher of the two input supply voltages. An undervoltage lockout circuit disables the chip until the voltage at  $V_{\text{CCHI}}$  is greater than 2.45V.

**V<sub>OUTLO</sub> (Pin 20):** Low Supply Voltage Output. This must be the lower of the two supply voltage outputs.

**GATELO (Pin 21):** The High Side Gate Drive for the Low Supply N-Channel Pass Transistor. An internal charge pump guarantees at least 10V of gate drive. The slope of the voltage rise at GATELO is set by the external capacitor connected between GATEHI and RAMP. When the circuit breaker trips GATELO is immediately pulled to GND.

**SETLO (Pin 22):** The Circuit Breaker Set Pin for the Low Supply. With a sense resistor placed in the supply path between  $V_{\text{CCLO}}$  and SETLO, the circuit breaker will trip when the voltage across the resistor exceeds 50mV for more than 20 $\mu\text{s}$ . To disable the circuit breaker,  $V_{\text{CCLO}}$  and SETLO should be shorted together.

**V<sub>CCLO</sub> (Pin 23):** The Positive Supply Input.  $V_{\text{CCLO}}$  must be equal to or lower voltage than  $V_{\text{CCHI}}$ . An undervoltage lockout circuit disables the chip until the voltage at  $V_{\text{CCLO}}$  is greater than 2.45V.

**AUXV<sub>CC</sub> (Pin 24):** The supply input for the GATELO and GATEHI discharge circuitry. Connect a 1 $\mu\text{F}$  capacitor to ground. AUXV<sub>CC</sub> is powered from  $V_{\text{CCLO}}$  via an internal Schottky diode and series resistor.

### BLOCK DIAGRAM

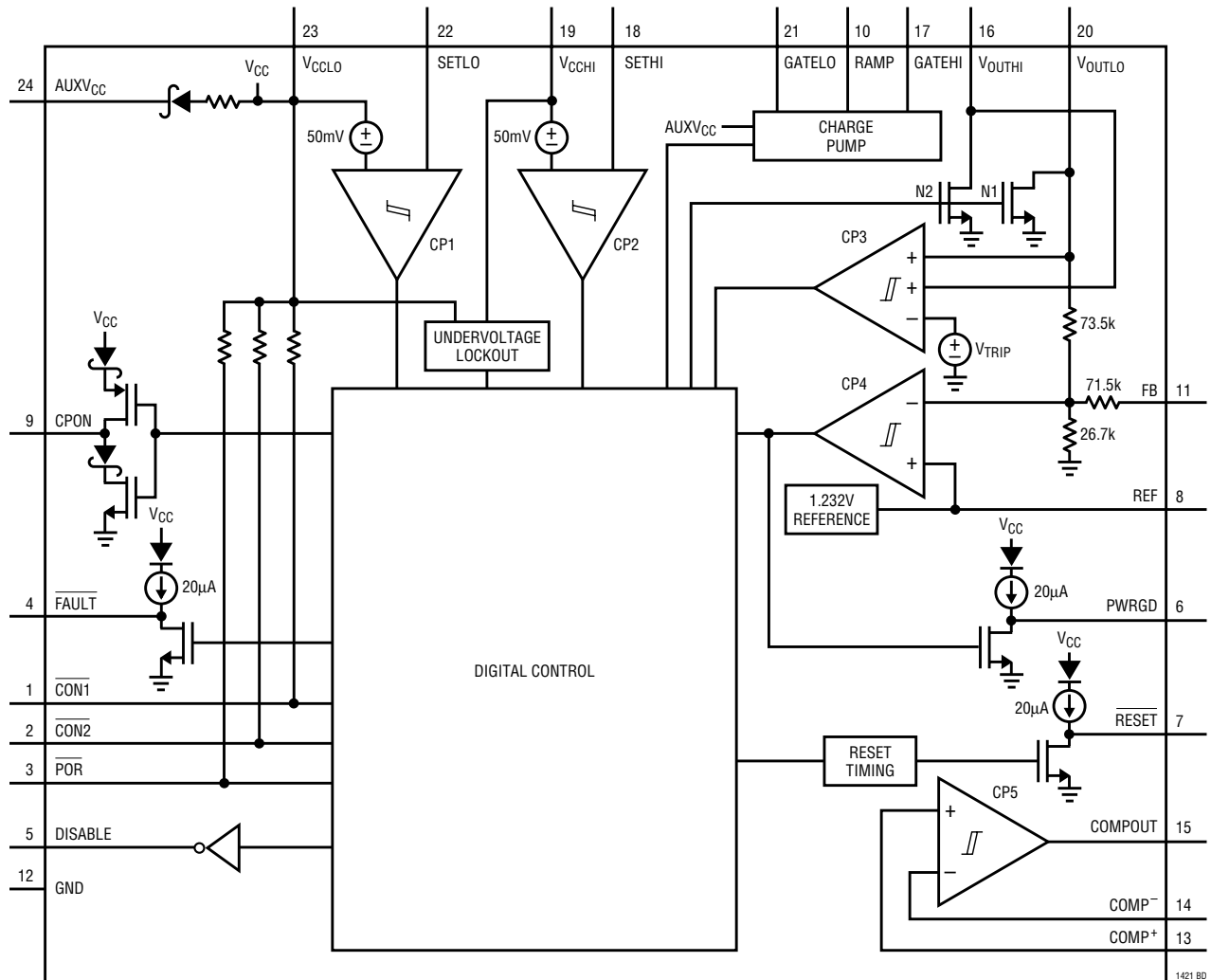

### SWITCHING TIME WAVEFORMS

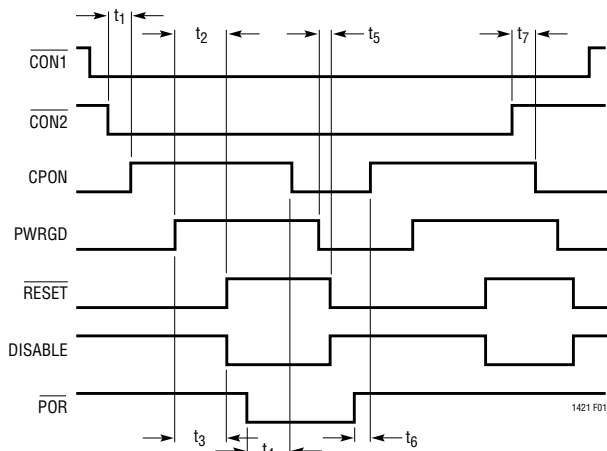

Figure 1. Nominal Operation Switching Waveforms

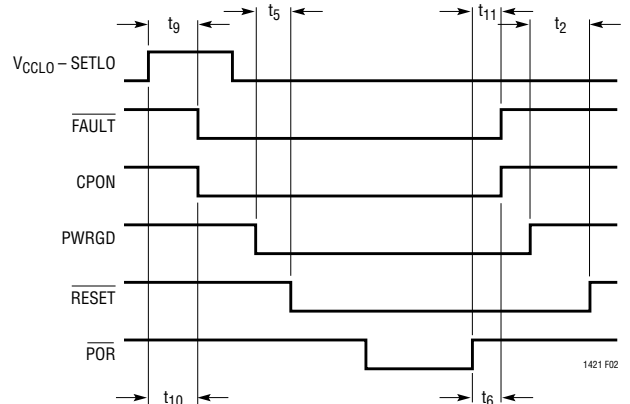

Figure 2. Fault Detection Switching



## APPLICATIONS INFORMATION

### Hot Circuit Insertion

When circuit boards are inserted into a live backplane, the supply bypass capacitors on the board can draw huge transient currents from the backplane power bus as they charge up. The transient currents can cause permanent damage to the connector pins and cause glitches on the system supply, causing other boards in the system to reset. At the same time, the system data bus can be disrupted when the board's data pins make or break connection.

The LTC1421 is designed to turn a board's supply voltages on and off in a controlled manner, allowing the board to be safely inserted or removed from a live backplane. The chip also provides a disable signal for the board's data bus buffer during insertion or removal and provides all the necessary supply supervisory functions for the board.

### Power Supply Ramping

The power supplies on a board are controlled by placing external N-channel pass transistors in the power path (Figure 3). R1 and R2 provide current fault detection. By ramping the gate of the pass transistor up at a controlled rate, the transient surge current ( $I = C \cdot dV/dt$ ) drawn from the main backplane supply can be limited to a safe value when the board makes connection.

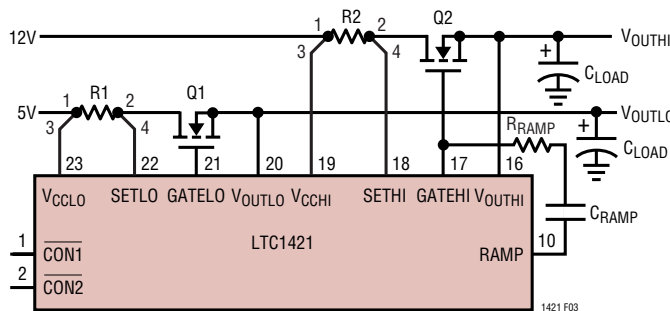

Figure 3: Supply Control Circuitry

When power is first applied to the chip, the gates of both N-channels, GATELO and GATEHI are pulled low. After the connection sense pins, CON1 and CON2 are both held low for at least 20ms, a  $20\mu A$  reference current is connected from the RAMP pin to GND. The voltage at GATEHI begins to rise with a slope equal to  $20\mu A/C_{RAMP}$  (Figure 4), where  $C_{RAMP}$  is an external capacitor connected between the

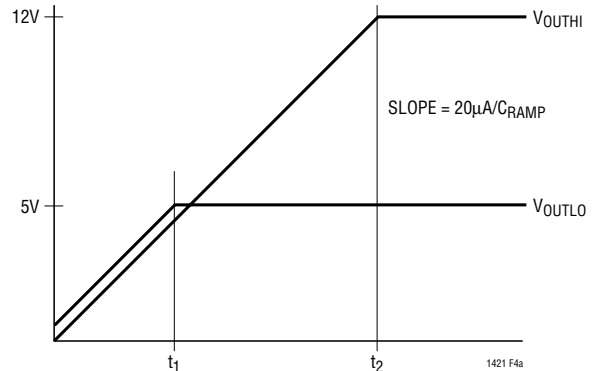

Figure 4: Supplies Turning On

RAMP and GATEHI pins. The voltage at the GATEHI pin is clamped one Schottky diode drop below GATELO.

The ramp time for each supply is equal to:  $t = (V_{CC}) (C_{RAMP})/20\mu A$ . During power down the gates are actively pulled down by two internal NFETs.

A negative supply voltage can be controlled using the CPON pin as shown in Figure 5.

When the board makes connection, the transistor Q3 is turned off because its gate is pulled low to  $-12V$  by R4. CPON is also pulled to  $-12V$ . When the charge pump is turned on, CPON is pulled to  $V_{CCLO}$  and the gate of Q3 will ramp up with a time constant determined by R4, R5 and C2. When the charge pump is turned off, CPON goes into a high impedance state, the gate of Q3 is discharged to  $V_{EE}$  with a time constant determined by R4 and C2, and Q3 turns off.

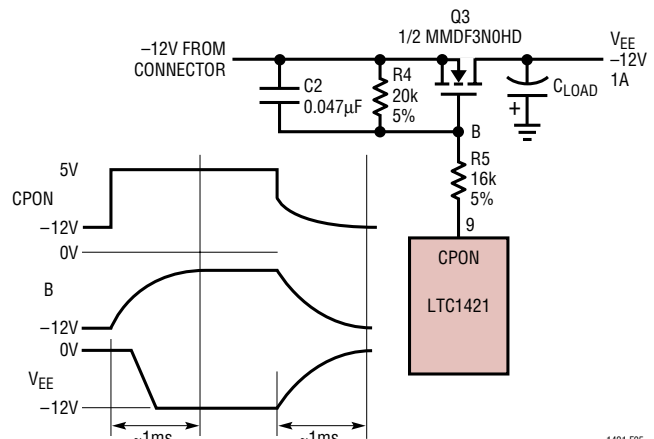

Figure 5: Negative Supply Control



## APPLICATIONS INFORMATION

### PWRGD and RESET

The LTC1421 uses a 1.232V bandgap reference, internal resistive divider and a precision voltage comparator to monitor  $V_{OUTLO}$  (Figure 6).

The reset threshold voltage for  $V_{OUTLO}$  is determined by the FB pin connection as summarized in Table 1.

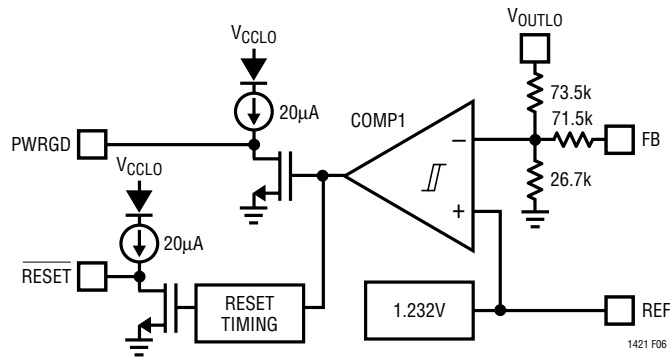

Figure 6. Supply Monitor Block Diagram

Table 1

FEEDBACK PIN	$V_{OUTLO}$ RESET VOLTAGE
Floating	4.65V
$V_{OUTLO}$	2.90V
GND	5.88V

When the  $V_{OUTLO}$  voltage rises above its reset threshold voltage, the comparator output goes low, and PWRGD is immediately pulled high to  $V_{CCLO}$  by a weak pull-up current source or external resistor (Figure 7, time points 1 and 4). After a 200ms delay, RESET is pulled high. The weak pull-up current source to  $V_{CCLO}$  on PWRGD and RESET have a series diode so the pins can be pulled above  $V_{CCLO}$  by an external pull-up resistor without forcing current back into  $V_{CCLO}$ .

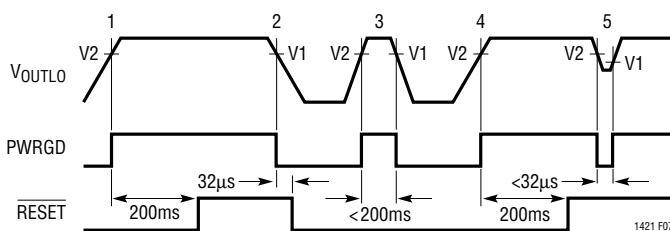

Figure 7. Power Monitor Waveforms

When  $V_{OUTLO}$  drops below its reset threshold, the comparator output goes high, and PWRGD is immediately pulled low (time point 2). After a 32µs delay, RESET is pulled low. The RESET delay allows the PWRGD signal to be used as an early warning that a reset is about to occur. If the PWRGD signal is used as an interrupt input to a microprocessor, a short power-down routine can be run before the reset occurs.

If  $V_{OUTLO}$  rises above the reset threshold for less than 200ms, the PWRGD output will trip, but the RESET output is not affected (time point 3). If  $V_{OUTLO}$  drops below the reset threshold for less than 32µs, the PWRGD output will trip, but again the RESET output will not be affected (time point 5).

### Voltage Comparator

The uncommitted voltage comparator (COMP2) can be used to monitor output voltages other than  $V_{OUTLO}$ . Figure 8a shows how the comparator can be used to monitor a 12V supply ( $V_{OUTH1}$ ), while the 5V supply ( $V_{OUTLO}$ ) generates a reset when it dips below 4.65V. When the 12V supply drops below 10.8V, COMP2OUT will pull low. The FB pin is left floating.

Figure 8b shows how the comparator can be used to monitor the 5V supply ( $V_{OUTH1}$ ) while the 3.3V supply ( $V_{OUTLO}$ ) generates a reset when it dips below 2.9V. When the 5V supply drops below 4.65V, COMP2OUT will pull low. The FB pin is tied to  $V_{OUTLO}$ .

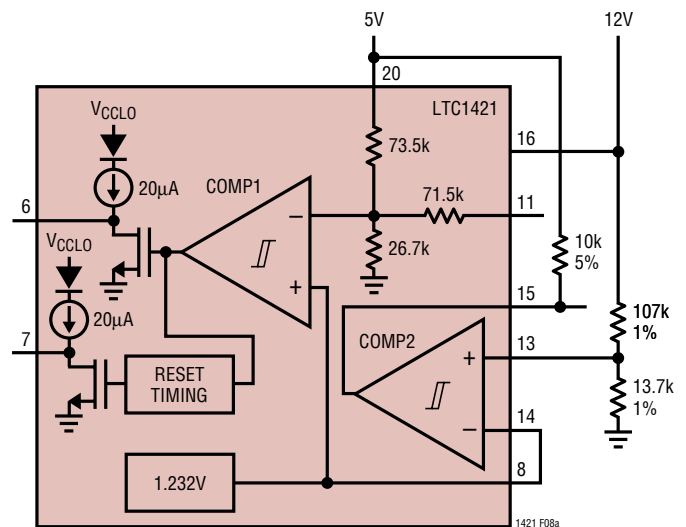

Figure 8a. Monitor 12V, Reset 5V at 4.65V

## APPLICATIONS INFORMATION

Figure 8c shows how the comparator can be used to generate a reset when the 12V supply ( $V_{OUTHI}$ ) drops below 10.8V. The 5V supply ( $V_{OUTLO}$ ) also generates a reset when it dips below 4.65V. When the 12V supply drops below 10.8V, COMP2OUT will pull the FB pin low setting the internal threshold voltage for comparator 1 to 5.88V. Since  $V_{OUTLO}$  is less than 5.88V, PWRGD immediately goes low and a reset is generated 32 $\mu$ s later.

Figure 8d shows how the comparator can be used to override the internal reset voltage for a 5V supply on  $V_{OUTLO}$ .

A 5.1k resistor is tied from the FB pin to  $V_{OUTLO}$ , setting the internal threshold to about 2.9V. The new reset threshold voltage is set by the external resistive divider connected to COMP2. When  $V_{OUTLO}$  drops below the new threshold, COMP2OUT pulls FB to ground, changing the internal threshold at COMP1 to 5.88V and generating a reset.

Finally, the comparator may be used to monitor a negative supply as shown in Figure 8e. The external resistor divider

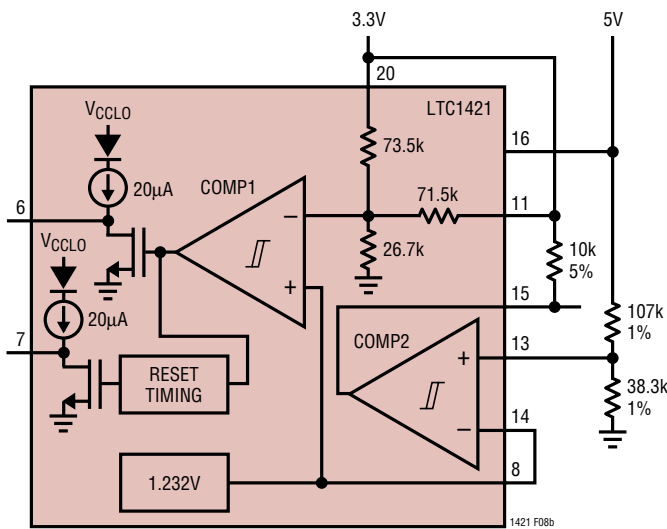

Figure 8b. Monitor 5V, Reset 3.3V at 2.9V

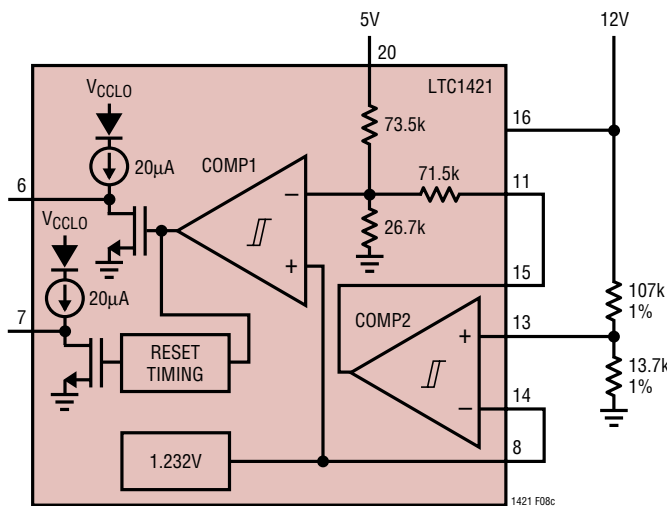

Figure 8c. Reset 12V at 10.8V, Reset 5V at 4.65V

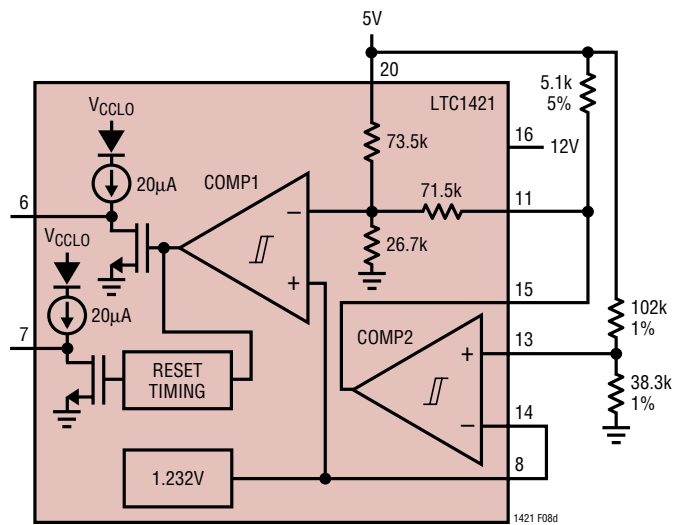

Figure 8d. Reset 5V at 4.5V

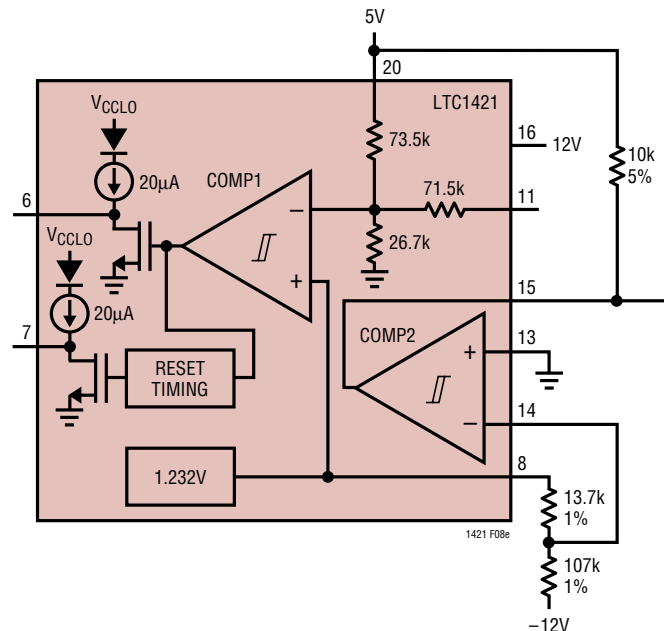

Figure 8e. Monitor -12V at -10.8V, Reset 5V at 4.65V

## APPLICATIONS INFORMATION

is connected between REF (Pin 8) and the negative supply and the trip point of Comparator 2 set to GND.

### Soft Reset Generation

A soft reset that doesn't cycle the supply voltage can be generated externally using Pin 11 (FB) as shown in Figure 9. For a 5V supply the FB pin is left floating to set the internal supply monitor trip voltage to 4.65V. However, if the FB pin is pulled to ground for more than 32 $\mu$ s via a push button or open-collector logic gate, the internal trip point will go to 5.88V and the  $\overline{\text{RESET}}$  pin will pull low.  $\overline{\text{RESET}}$  will remain low for 200ms after the FB pin is released. The  $\overline{\text{RESET}}$  signal will also be pulled low when the voltage at the  $V_{\text{OUTLO}}$  pin dips below 4.65V for more than 32 $\mu$ s. When using a 3.3V supply, a 1k resistor must be connected from the FB pin to  $V_{\text{CCLO}}$  to set the internal trip point to 2.90V.

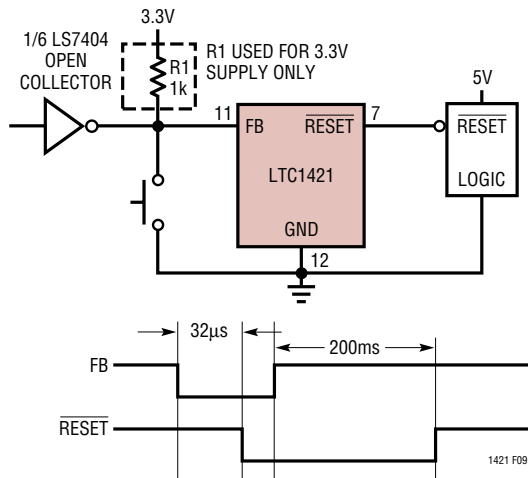

Figure 9. Generating a Soft Reset

### Undervoltage Lockout

On power-up, an undervoltage lockout circuit prevents the GATELO and GATEHI charge pumps from turning on until  $V_{\text{CCLO}}$  and  $V_{\text{CCHI}}$  have both exceeded 2.45V.

### Electronic Circuit Breaker

The LTC1421 features an electronic circuit breaker function that protects against short circuits or excessive currents on the supplies. By placing a sense resistor between the supply input and set pin of either supply, the circuit breaker will be tripped whenever the voltage across the

sense resistor is greater than 50mV for more than 20 $\mu$ s. When the circuit breaker trips, both N-channel MOSFETs are quickly turned off,  $\overline{\text{FAULT}}$  and PWRGD go low and  $\overline{\text{RESET}}$  is pulled low 32 $\mu$ s later.  $\overline{\text{FAULT}}$  can be connected to a LED or a logic signal back to the host to indicate a faulty board. The chip will remain in the tripped state until a power-on reset is generated, or the power on  $V_{\text{CCHI}}$  and  $V_{\text{CCLO}}$  is cycled. If the circuit breaker feature is not used, short  $V_{\text{CCLO}}$  to SETLO and  $V_{\text{CCHI}}$  to SETHI.

If more than 20 $\mu$ s of response time is needed to reject supply noise, an external resistor and capacitor can be added to the sense circuit as shown in Figure 10.

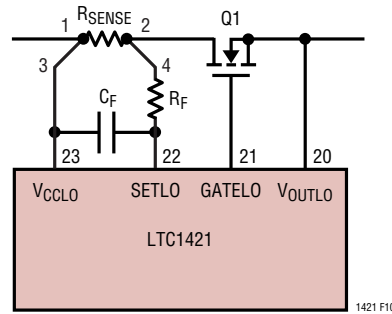

Figure 10. Short-Circuit Protection Circuit

### Auxiliary $V_{\text{CC}}$

When a short circuit occurs on the board, it is possible to draw enough current to cause the backplane supply voltage to collapse. If the input supply voltage collapses to a low enough voltage and the LTC1421 gate drive circuitry is unable to shut off the N-channel pass transistors, the system might freeze up in a permanent short condition.

To prevent this from occurring, the gate discharge circuitry inside the LTC1421 is powered from  $\text{AUXV}_{\text{CC}}$ , which is in turn powered from  $V_{\text{CCLO}}$  through an internal Schottky diode and current limiting resistor (Figure 11).

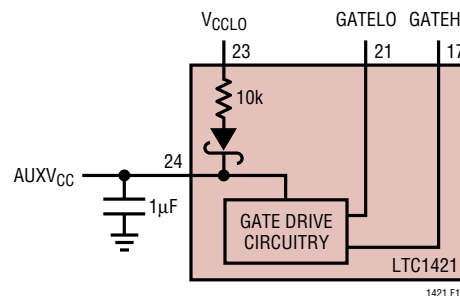

Figure 11.  $\text{AUXV}_{\text{CC}}$  Circuitry

## APPLICATIONS INFORMATION

When  $V_{CCLO}$  collapses, there is enough energy stored on the  $1\mu\text{F}$  capacitor connected to  $AUXV_{CC}$  to keep the gate discharge circuitry alive long enough to fully turn off the external N-channels.

### Power N-Channel Selection

The  $R_{DS(ON)}$  of the external pass transistor must be low enough so that the voltage drop across it is about 200mV or less at full current. If the  $R_{DS(ON)}$  is too high, the voltage drop across the transistor might cause the output voltage to trip the reset circuit. Table 2 lists the transistors that are recommended for use with the LTC1421.

**Table 2. N-Channel Selection Guide**

CURRENT LEVEL (A)	PART NUMBER	MANUFACTURER	DESCRIPTION
0 to 1	MMDF2N02E	ON Semiconductor	Dual N-Channel SO-8 $R_{DS(ON)} = 0.1\Omega$
1 to 2	MMDF3N02HD	ON Semiconductor	Dual N-Channel SO-8 $R_{DS(ON)} = 0.09\Omega$
2 to 5	MTB30N06	ON Semiconductor	Single 30A N-Channel DD Pak $R_{DS(ON)} = 0.05\Omega$
5 to 10	MTB50N06E	ON Semiconductor	Single N-Channel DD Pak $R_{DS(ON)} = 0.025\Omega$
10 to 20	MTB75N05HD	ON Semiconductor	Single N-Channel DD Pak $R_{DS(ON)} = 0.0095\Omega$

### Data Bus

When a board is inserted or removed from the host, care must be given to prevent the system data bus from being corrupted when the data pins make or break contact. One problem is that the fully discharged input or output capacitance of the logic gates on the board will draw an inrush current when the data bus pins first make contact. The inrush current can temporarily corrupt the data bus, but usually will not cause long term damage. The problem can be minimized by insuring the input or output data bus capacitance is kept as small as possible.

The second, and more serious problem involves the diodes to  $V_{CC}$  at the input and output of most logic families (Figure 12).

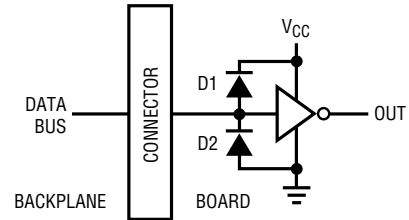

1421 F12

**Figure 12. Typical Logic Gate Loading the Data Bus**

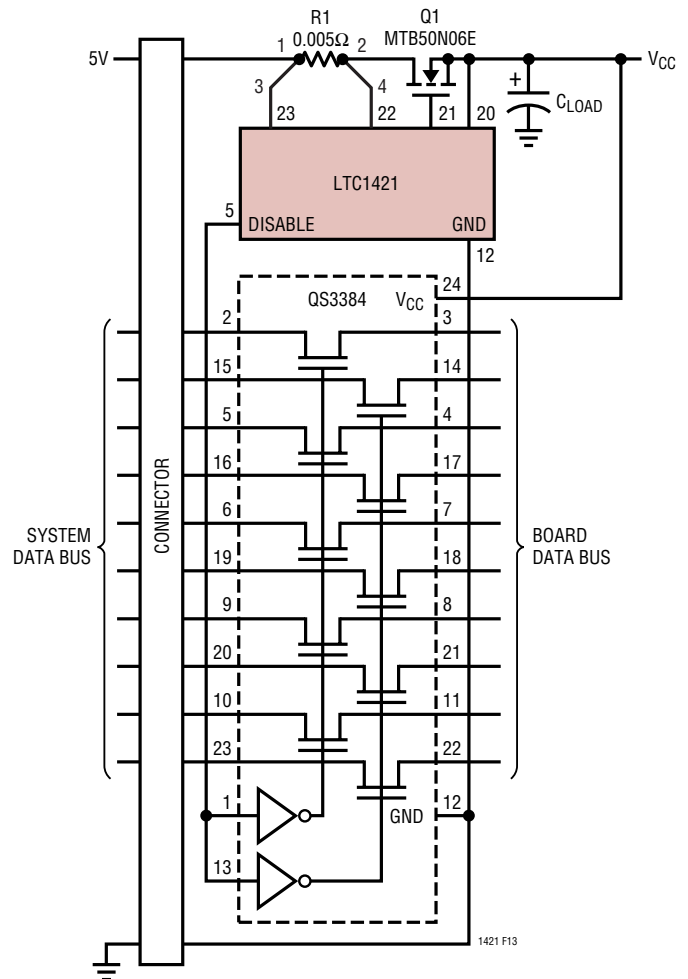

1421 F13

**Figure 13: Buffering the Data Bus**

With the board initially unpowered, the  $V_{CC}$  input to the logic gate is at ground potential. When the data bus pins make contact, the bus line is clamped to ground through the input diode D1 to  $V_{CC}$ . Large amounts of current can flow through the diode and cause the logic gate to latch up and destroy itself when the power is finally applied. This

## APPLICATIONS INFORMATION

can usually be prevented by using logic that does not include the clamping diodes such as the QSI 74FCTT family from Quality Semiconductor, or by using a data bus switch such as the 10-bit QS3384 QuickSwitch also from Quality Semiconductor (Tel: 408-450-8000). The QuickSwitch bus switch contains an N-channel placed in series with the data bus. The switch is turned off when the board is inserted and then enabled after the power is stable. The switch inputs and outputs do not have a parasitic diode back to  $V_{CC}$  and have very low capacitance.

The LTC1421 is designed to work directly with the QuickSwitch bus switch as shown in Figure 13.

The DISABLE signal is connected to the enable pins of the QS3384, and each switch is placed in series with a data bus signal. When the board is inserted, the DISABLE

signal is pulled high, turning off the switches. After the board supply voltage ramps up and  $\overline{\text{RESET}}$  goes high, DISABLE will pull low enabling the switches.

### Board Insertion Timing

When the board is inserted, GND pin makes contact first, followed by  $V_{CCHI}$  and  $V_{CCLO}$  (Figure 14, time point 1). DISABLE is immediately pulled high, so the data bus switch is disabled. At the same time  $\overline{\text{CON1}}$  and  $\overline{\text{CON2}}$  make contact and are shorted to ground on the host side (time point 3). Since most boards need to be rocked back and forth to get them in place, there is a period of time when only one side of the connector is making contact.  $\overline{\text{CON1}}$  and  $\overline{\text{CON2}}$  should be located at opposite ends of the connector.

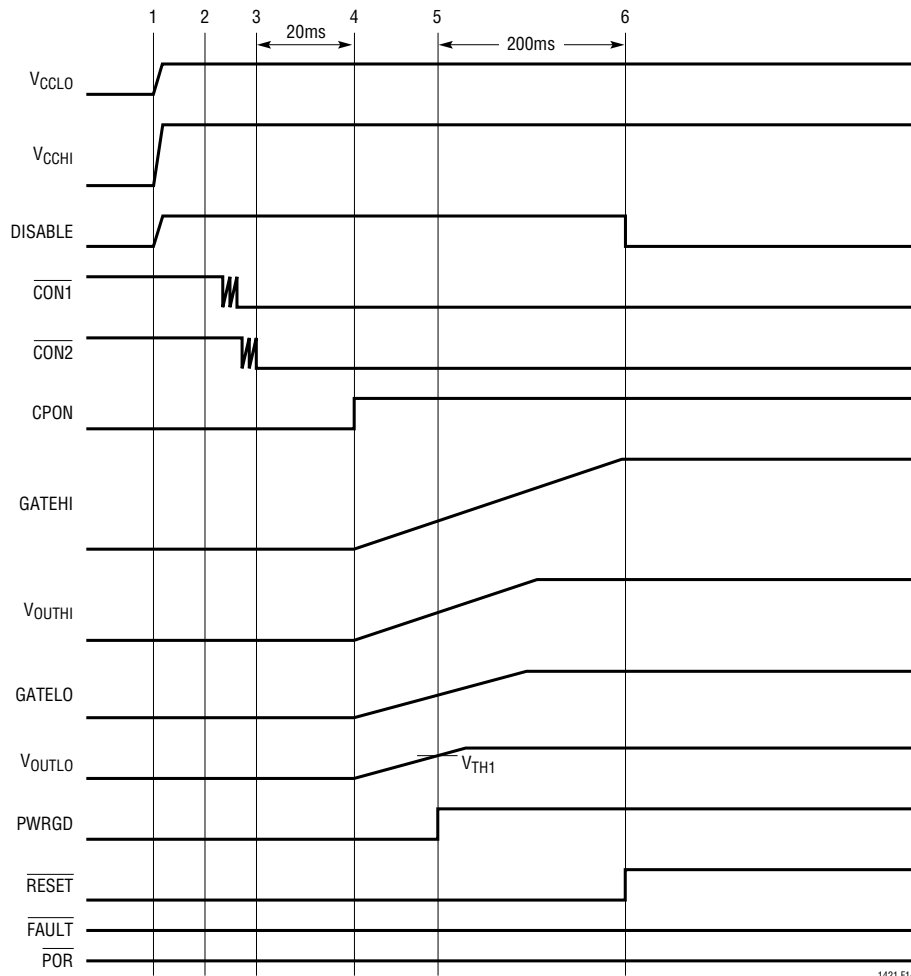

Figure 14. Board Insertion Timing

1421 F14

## APPLICATIONS INFORMATION

When  $\overline{\text{CON1}}$  and  $\overline{\text{CON2}}$  are both forced to ground for more than 20ms, the LTC1421 assumes that the board is fully connected to the host and power-up can begin. When  $V_{\text{CCLO}}$  and  $V_{\text{CCHI}}$  exceed the 2.45V undervoltage lockout threshold, the 20 $\mu\text{A}$  current reference is connected from RAMP to GND, the charge pumps are turned on and CPON is forced high (time point 4).  $V_{\text{OUTH1}}$  and  $V_{\text{OUTLO}}$  begin to ramp up. When  $V_{\text{OUTLO}}$  exceeds the reset threshold voltage, PWRGD will immediately be forced high (time point 5). After a 200ms delay,  $\overline{\text{RESET}}$  will be pulled high and  $\overline{\text{DISABLE}}$  will be pulled low, enabling the data bus (time point 6).

### Ground Sense Comparator

When  $\overline{\text{POR}}$  is pulled low for more than 20ms,  $\text{GATELO}$  and  $\text{GATEHI}$  are pulled to ground and  $V_{\text{OUTLO}}$  and  $V_{\text{OUTH1}}$  will be discharged. If  $\overline{\text{POR}}$  is pulled back high while  $V_{\text{OUTLO}}$  and  $V_{\text{OUTH1}}$  are still ramping down, the discharge will continue. When they drop below the  $V_{\text{TRIP}}$  point, a power-

up sequence will begin automatically. The trip point potential for LTC1421 is set at 0.1V and 2.5V for LTC1421-2.5.

In applications, where either  $V_{\text{OUTLO}}$  or  $V_{\text{OUTH1}}$  might be forced above 100mV before power-up, the LTC1421-2.5 should be used. This could occur when leakage through the body diode of the logic chips keeps  $V_{\text{OUTLO}}$  high or in the case where logic lines are precharged.

In other applications, where outputs need to drop to near ground potential before ramping up again to ensure proper initial state for the logic chips, the LTC1421 should be used.

### Power-On Reset Timing

The  $\overline{\text{POR}}$  input is used to completely cycle the power supplies on the board or to reset the electronic circuit breaker feature. The  $\overline{\text{POR}}$  pin can be connected to a grounded push button, toggle switch or a logic signal from the host. When  $\overline{\text{POR}}$  is pulled low for more than 20ms, a power-on reset sequence begins (Figure 15,

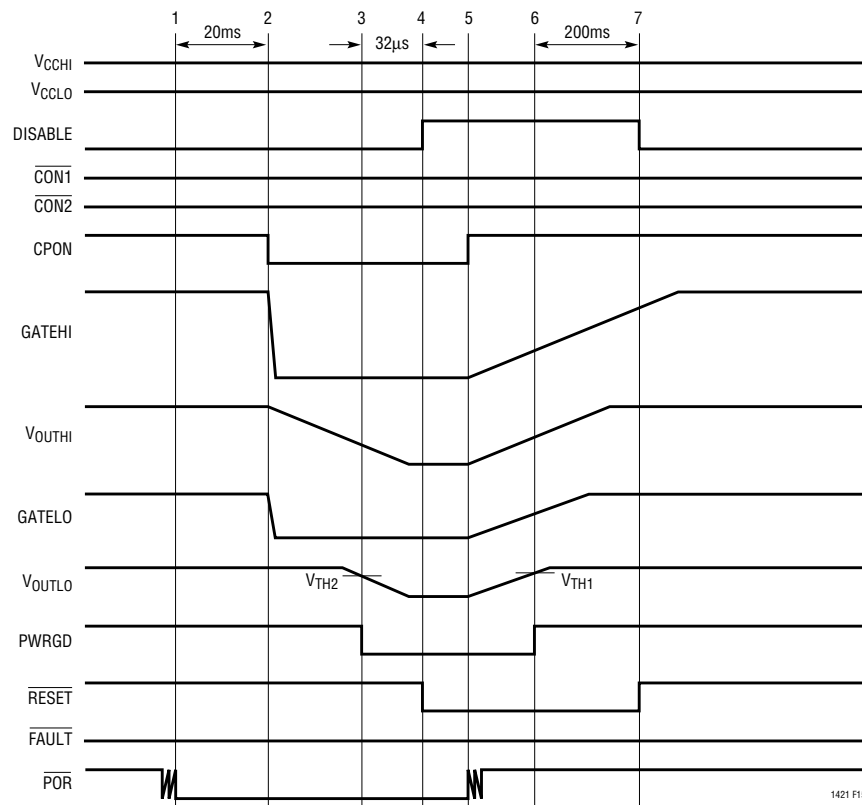

Figure 15. Power-On Reset Timing

## APPLICATIONS INFORMATION

time point 2). Pulses less than 20ms on  $\overline{\text{POR}}$  are ignored. CPON goes low. Both GATEHI and GATELO will be actively pulled down to GND. When  $V_{\text{OUTLO}}$  drops below its reset threshold voltage, PWRGD will immediately pull low (time point 3) followed by  $\overline{\text{RESET}}$  and  $\overline{\text{DISABLE}}$  32 $\mu\text{s}$  later (time point 4). Both supplies will be discharged to ground and stay there until  $\overline{\text{POR}}$  is pulled high.

The circuit breaker can be reset by pulling  $\overline{\text{POR}}$  low. After  $\overline{\text{POR}}$  is low for more than 20ms, the chip will immediately try to power up the supplies once the outputs are below the  $V_{\text{TRIP}}$  point.

### Circuit Breaker Timing

The waveforms for the circuit when a short occurs on either supply during board insertion are shown in

Figure 16. Time points 1 to 4 are the same as the board insertion example, but at time point 5, a short circuit is detected on one of the supplies. The charge pumps are immediately turned off, the outputs  $V_{\text{OUTH1}}$  and  $V_{\text{OUTLO}}$  are actively pulled to GND and the CPON and  $\overline{\text{FAULT}}$  pins are pulled low. At time point 6, the circuit breaker is reset by pulling  $\overline{\text{POR}}$  low. After  $\overline{\text{POR}}$  has been low for 20ms (time point 7), CPON and  $\overline{\text{FAULT}}$  are pulled high, the 20 $\mu\text{A}$  reference current is connected to RAMP and the charge pumps are enabled.  $V_{\text{OUTH1}}$  and  $V_{\text{OUTLO}}$  ramp up at a controlled rate. When  $V_{\text{OUTLO}}$  has exceeded its reset threshold, the PWRGD signal is pulled high (time point 8). After a 200ms delay,  $\overline{\text{RESET}}$  is pulled high and  $\overline{\text{DISABLE}}$  goes low.

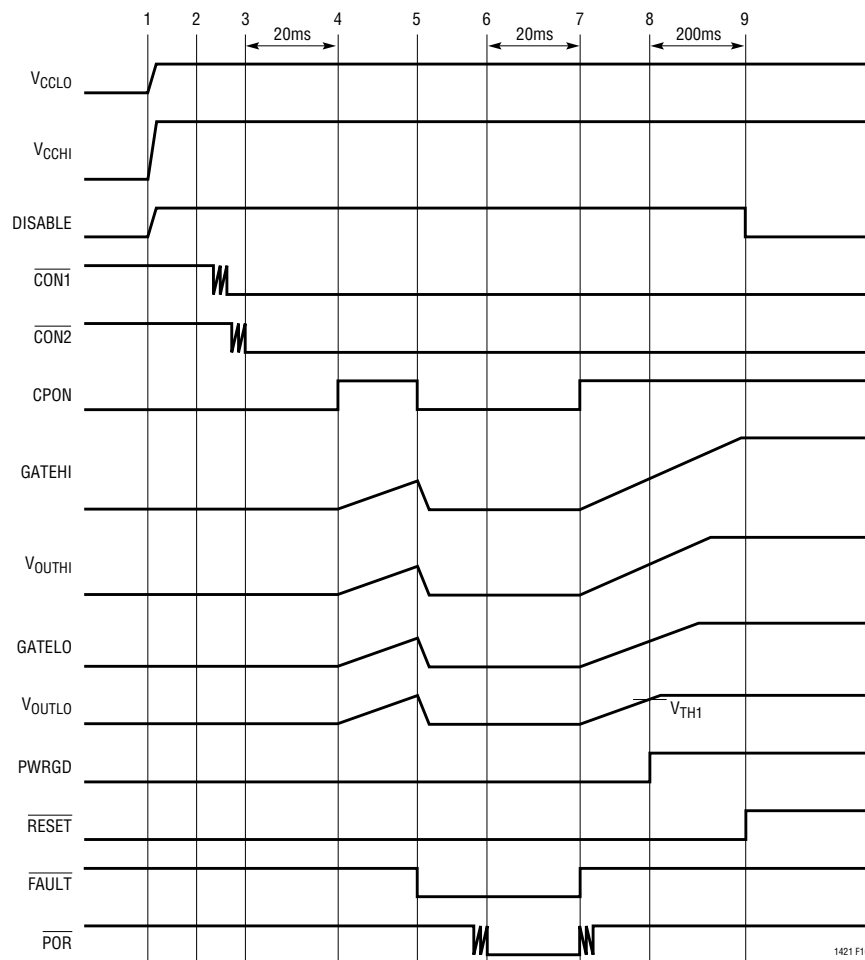

Figure 16. Circuit Breaker Timing



## APPLICATIONS INFORMATION

### Board Removal Timing

When the board is removed from the host, the sequence happens in reverse (Figure 17). Since  $\overline{\text{CON1}}$  and  $\overline{\text{CON2}}$  are the shortest pins, they break connection first and are internally pulled high (time point 1). The charge pumps are turned off, CPON is pulled low.  $V_{\text{OUTLO}}$  and  $V_{\text{OUTH}}$  are actively pulled down. When  $V_{\text{OUTLO}}$  falls below its reset threshold (time point 2) PWRGD is pulled low. To allow

time for power fail information to be stored in nonvolatile memory, the falling edge of  $\overline{\text{RESET}}$  (time point 3) is delayed by  $32\mu\text{s}$  from the falling edge of PWRGD.

Finally, the input supply pins  $V_{\text{CCHI}}$  and  $V_{\text{CCLO}}$  break contact (time point 4). If staggered pins are not used, the board may be powered down prior to removal by switching the POR pin to ground with a toggle switch.

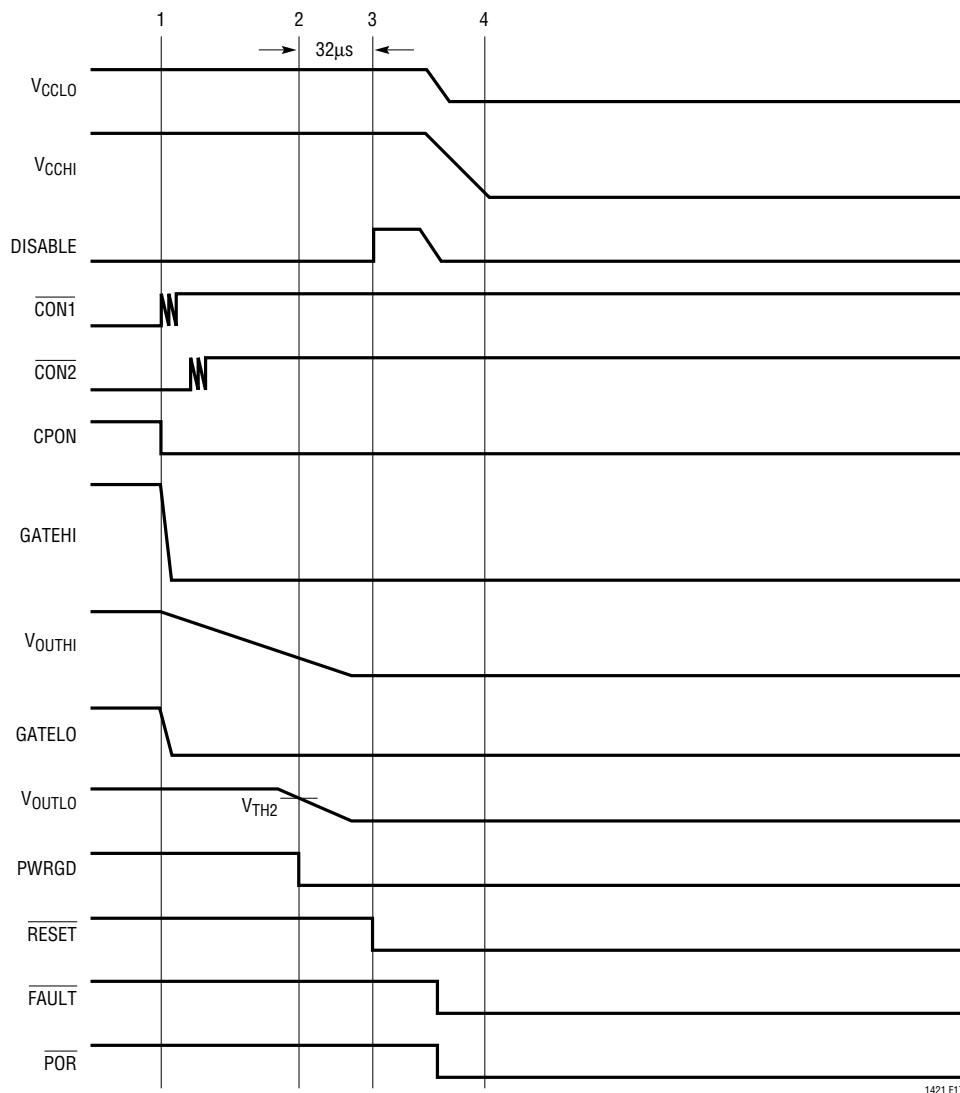

Figure 17. Board Removal Timing

## APPLICATIONS INFORMATION

### 5V Only Applications

The LTC1421 may be used in 5V only applications as shown in Figure 18. A soft reset can be generated from the backplane via an open-collector inverter driving the FB (Pin 11) or by a push button to ground. A hard power reset is generated from the backplane via an open-collector inverter driving the POR (Pin 3). A hard reset cycles the power on the board or resets the electronic circuit breaker. The comparator is used to monitor the board supply voltage and

will pull the  $\overline{\text{POWERGOOD}}$  signal low as long as the supply remains above 4.65V. Note that a soft reset will not affect the  $\overline{\text{POWERGOOD}}$  signal. The  $\overline{\text{FAULT}}$  signal is also monitored to determine that the circuit breaker has tripped.

### -48V and 24V Applications

The LTC1421 may be used in -48V applications as shown in Figure 19. The LTC1421 provides the hot insertion protection, while the 5V supply is generated by a power

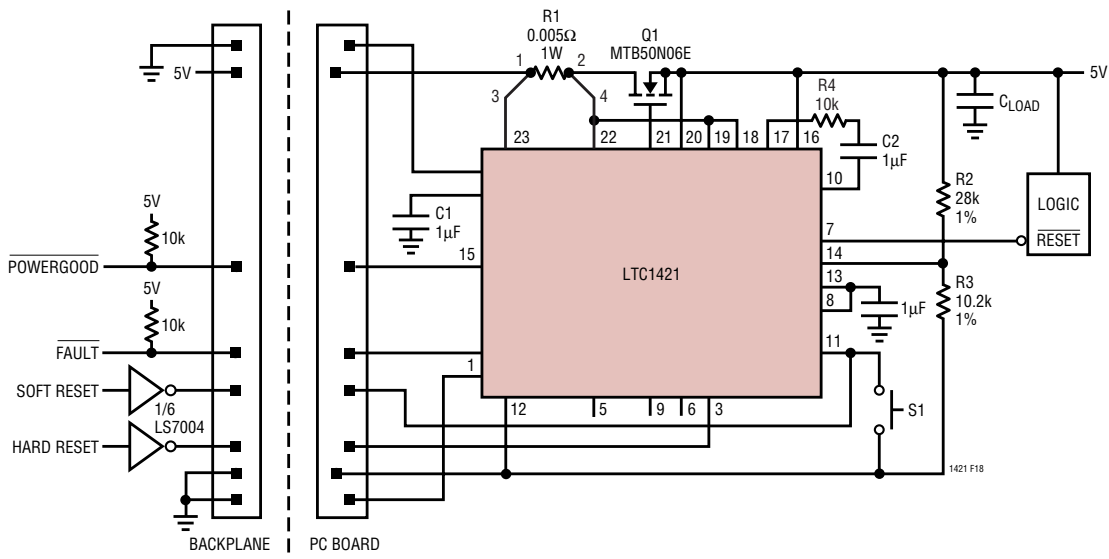

Figure 18. 5V Only Application with Soft Reset

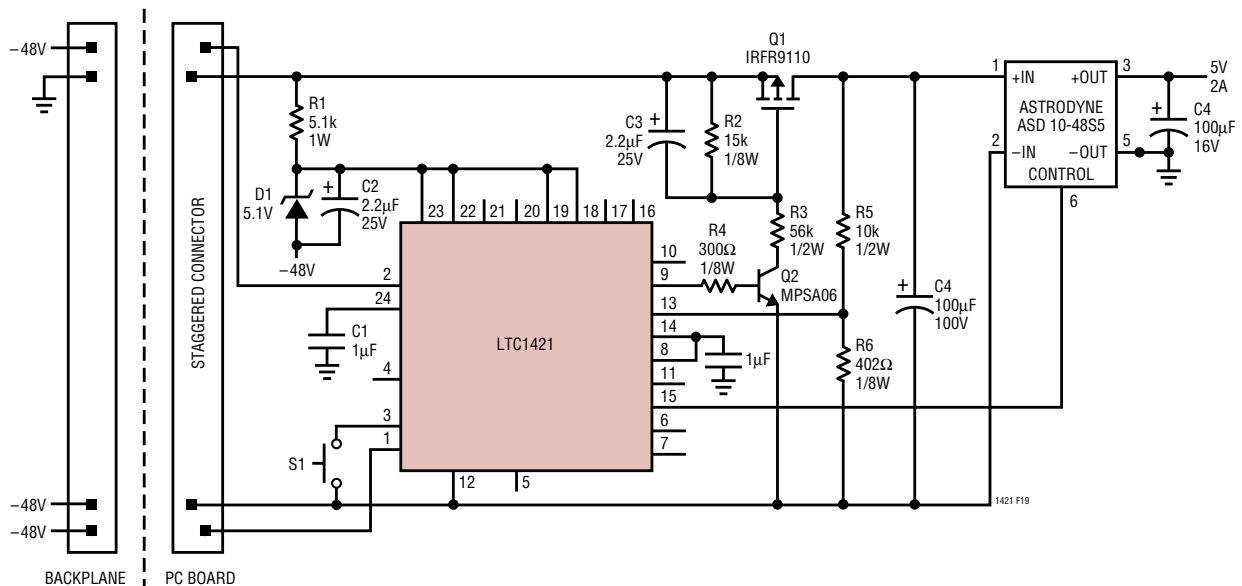

Figure 19. -48V to 5V Hot Swappable Supply

## APPLICATIONS INFORMATION

module. The ground pin for the LTC1421 is connected to  $-48\text{V}$ ; Zener diode D1 and resistor R1 provide the positive supply for the chip. Bypass capacitor C4 is protected against inrush current by P-channel Q1. When the board is inserted into the backplane, transistor Q1 is turned off by resistor R2. When the connection sense pins, CON1 and CON2 have been connected to  $-48\text{V}$  for more than 20ms, CPON pulls high turning on Q2 and the gate of Q1 starts to pull low with a time constant determined by R2, R3 and C3. At the same time, the voltage at the input to the power module starts to ramp up. When the voltage across the inputs to the power module reaches the comparator trip level set by R5 and R6, in this case  $-32\text{V}$ , the comparator output pulls high and turns on the 5V supply.

A cheaper solution is shown in Figure 20 using the LT<sup>®</sup>1170HV switcher. Again P-channel transistor Q1 protects the bypass capacitors against inrush current and resistors R5 and R6 set the comparator trip voltage. The LT1170HV is turned on via the  $V_C$  pin. Resistors R11, R14 and transistor Q4 provide a monitoring path for the RESET signal which is level shifted up to 5V through an optoisolator.

The P-channel power FET is being replaced by an N-channel FET in Figure 21 for the  $-48\text{V}$  application. Again, Zener Diode D1 and resistor R1 provide the positive supply for the chip. Capacitor C1 is to insure Q1 stays off when the board is being hot inserted into the backplane. The resistor divider R2 and R3, along with the internal comparator, perform the undervoltage lock out function. Q1 would only be turned on when the input supply voltage is lower than  $-42\text{V}$ . The power module would then be turned on by the optoisolator, 4N25, when the module's input voltage reaches 47V.

Figure 22 shows how to use the LTC1421 with a 24V supply and a LT1074CT step-down switcher. Resistors R5 and R6 set the turn-on threshold to 22V. All of the supervisory signals can be used without level shifting.

Figure 23 shows how to use the LTC1421 with a 5V supply and an LTC1430CS8 synchronous step-down switching regulator to generate 3.3V output at up to 10A for microprocessors. Resistors R4, R8 and R9 set the turn-on voltage at 4.8V and the turn-off at 4.25V. Pushbutton switch S1 provides users a way to reset the output while S2 is used to soft-reset the microprocessor only.

Figure 24 shows how to use the LTC1421 with a 5V supply and a  $-48\text{V}$  supply that is used to generate a  $\pm 12\text{V}$  supply using a supply module. Resistors R3 and R4 are used to monitor the input voltage to the supply module. The module is prevented from turning on via the optoisolator until the input voltage reaches  $-36\text{V}$ . Zener diode D2 prevents the CPON pin of the LTC1421 from being damaged by excessive voltage.

Figure 25 shows how to use the LTC1421 to do overvoltage protection. Resistors R3 and R4 set the trip point at 7V. When the input supply voltage rises above 7V, Q2 is turned on and Q1 turned off while Q3 helps to discharge the output voltage.

Figure 26 shows how to use the LTC1421 to control both the power-up and power-down sequence of the outputs. The 5V output would be powered up first followed by the 3V output. At power-down sequence, the 3V output would go down first followed by the 5V supply.

Figure 27 shows how to use the LTC1421 to switch 3.3V, 5V, 12V and  $-12\text{V}$  supplies for PCI application. The ramp-up rate for 3.3V, 5V and 12V is determined by the ramp capacitor C2 while the  $-12\text{V}$  supply is controlled by R7 and C3. The internal comparator is being used to do the overcurrent protection for Q4 with the trip point set by resistors R6 and R8. The  $-12\text{V}$  supply does not have overcurrent protection. R10 is used to set the power good signal trip point at 10V. When the 12V output rises above 10V, the PCI controller gets a power good signal followed by RESET after 200ms.



## APPLICATIONS INFORMATION

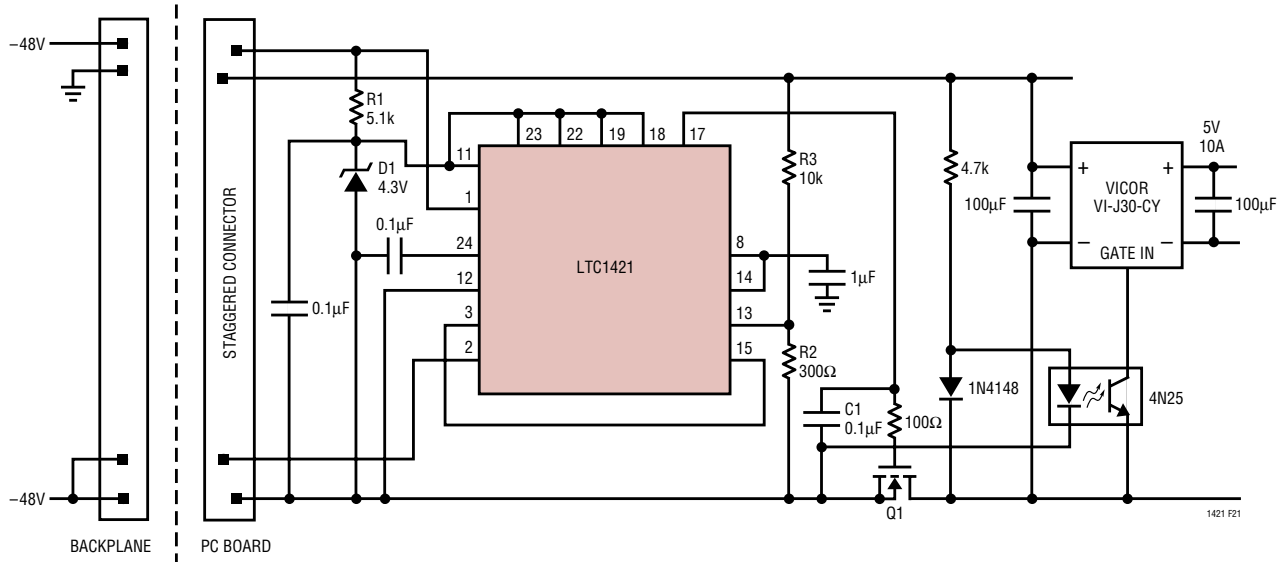

Figure 21. -48V to 5V Hot Swappable Supply

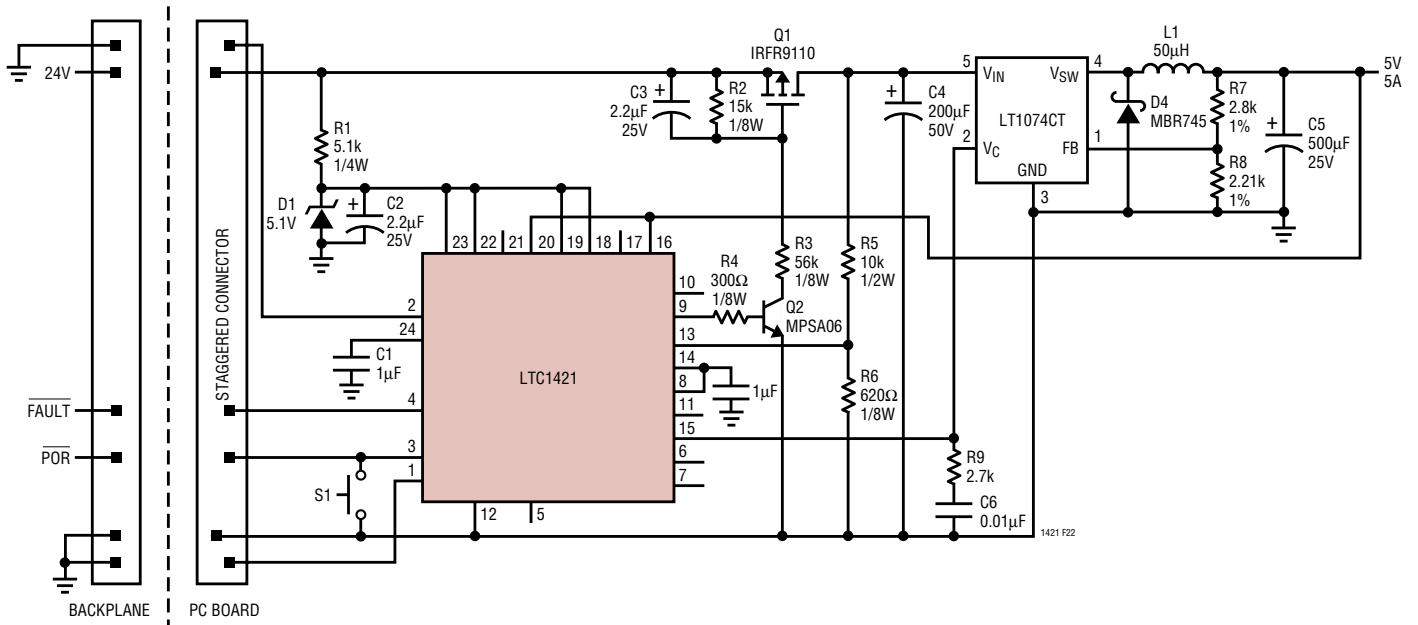

Figure 22. 24V to 5V Hot Swappable Supply Using the LT1074CT

APPLICATIONS INFORMATION

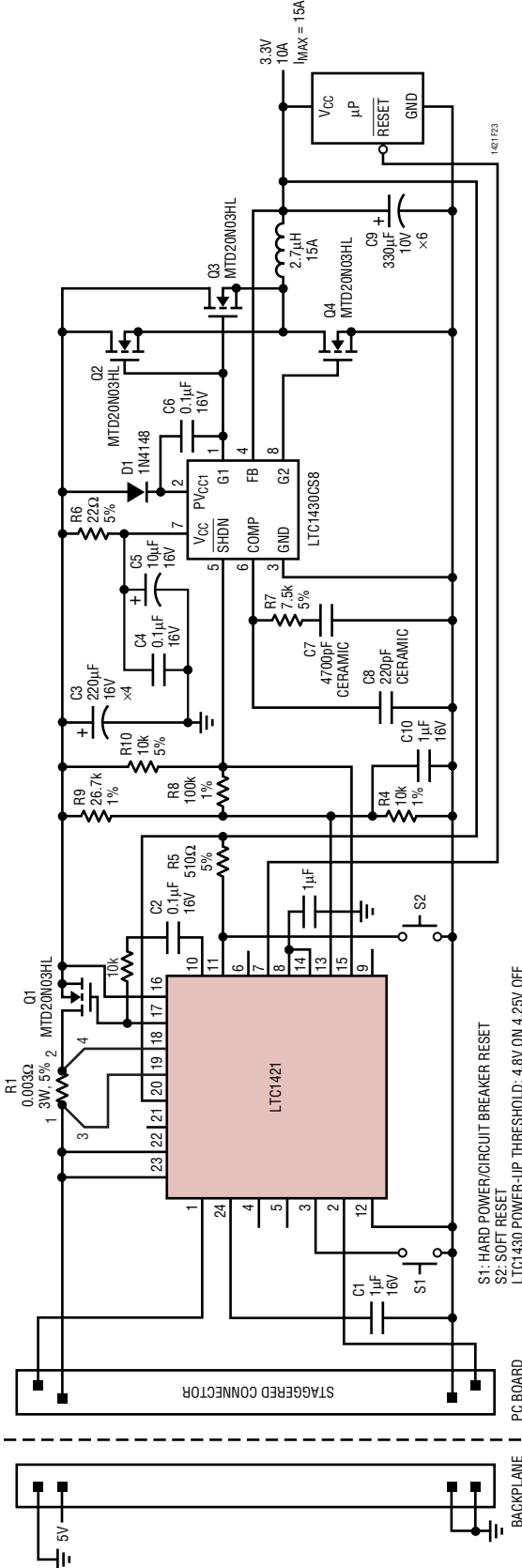

Figure 23. 5V to 3.3V Hot Swappable Supply Using the LTC1430CS8

APPLICATIONS INFORMATION

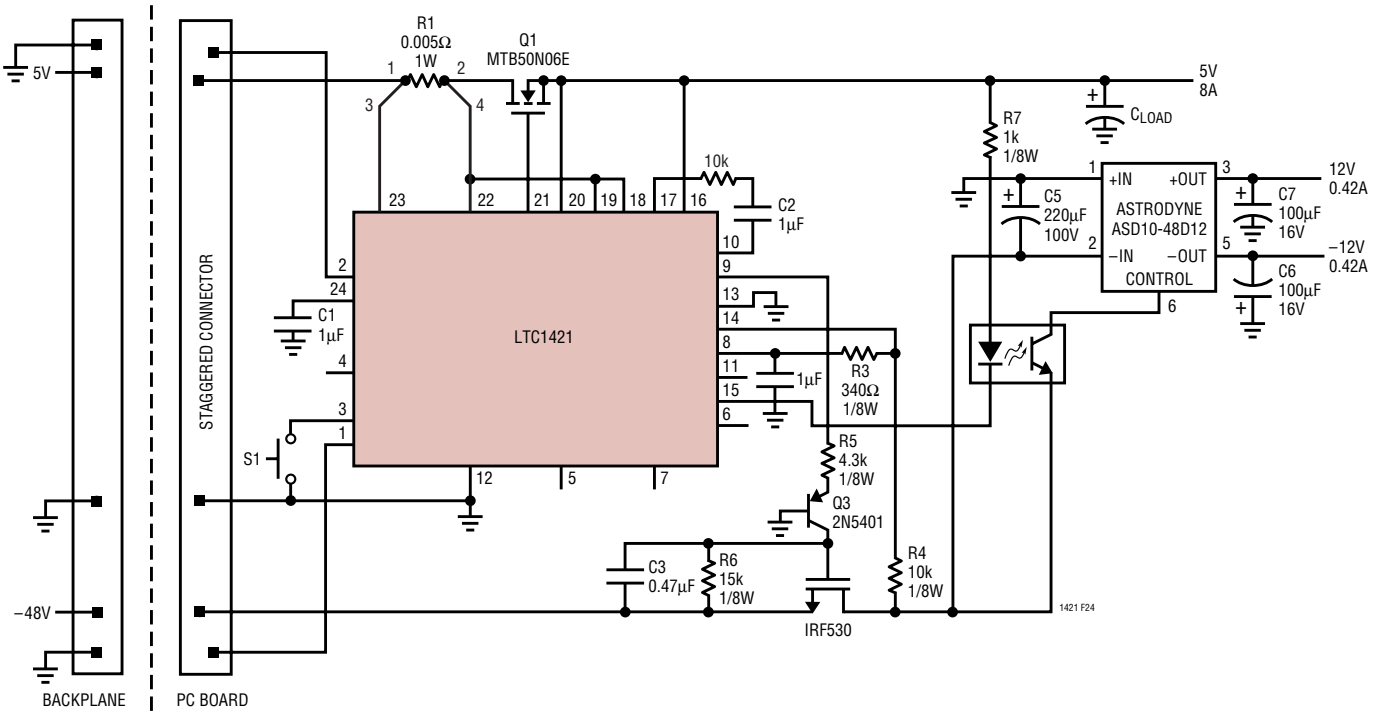

Figure 24. 5V and -48V to ±12V Hot Swappable Supply

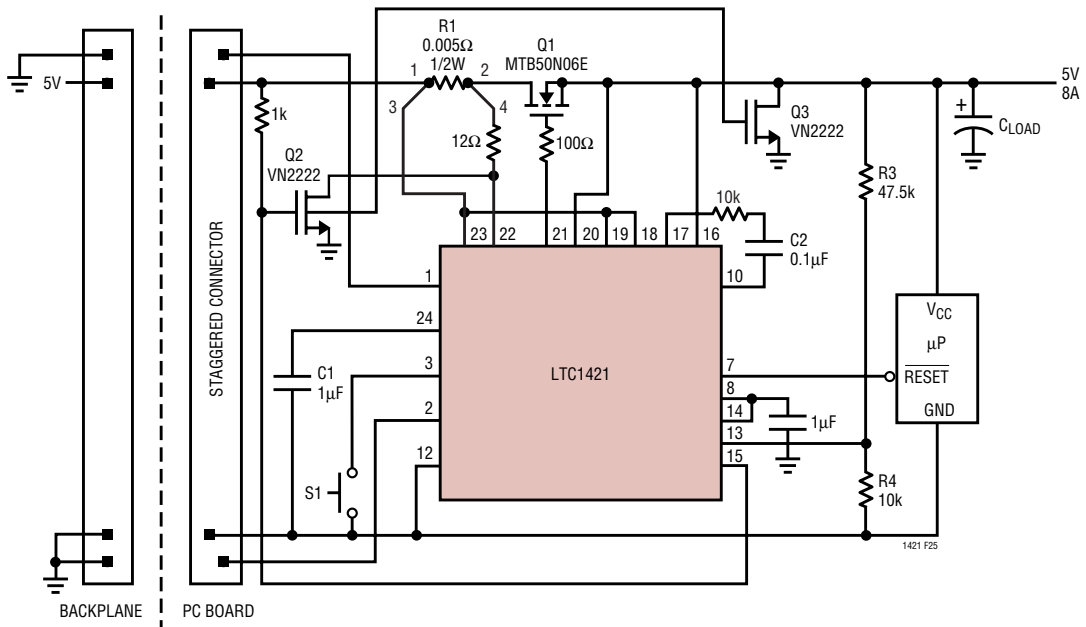

Figure 25. Hot Swappable 5V Supply with Overvoltage Protection



# APPLICATIONS INFORMATION

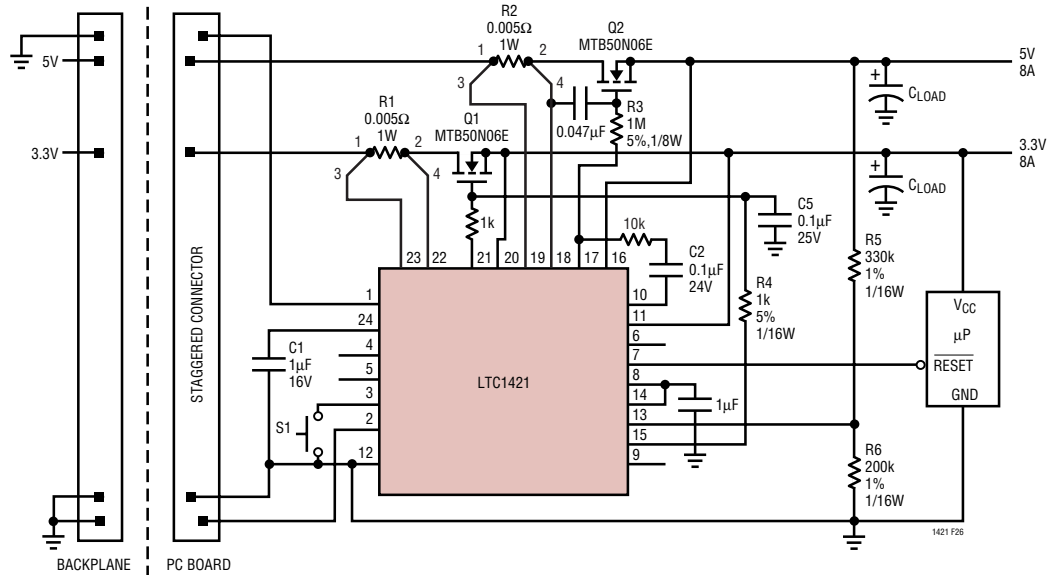
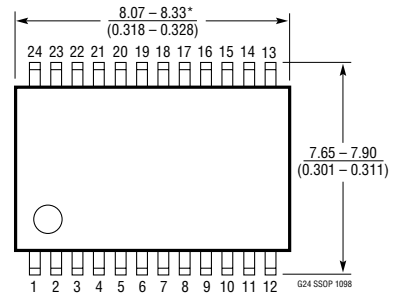
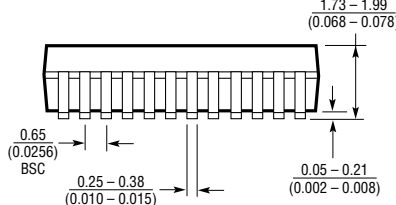
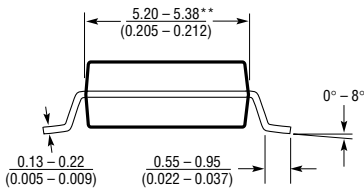

Figure 26. Power-Up and Power-Down Sequence Controller

# PACKAGE DESCRIPTION

Dimensions in inches (millimeters) unless otherwise noted.

## G Package 24-Lead Plastic SSOP (0.209) (LTC DWG # 05-08-1640)



NOTE: DIMENSIONS ARE IN MILLIMETERS  
 \*DIMENSIONS DO NOT INCLUDE MOLD FLASH. MOLD FLASH SHALL NOT EXCEED 0.152mm (0.006") PER SIDE  
 \*\*DIMENSIONS DO NOT INCLUDE INTERLEAD FLASH. INTERLEAD FLASH SHALL NOT EXCEED 0.254mm (0.010") PER SIDE

## SW Package 24-Lead Plastic Small Outline (Wide 0.300) (LTC DWG # 05-08-1620)

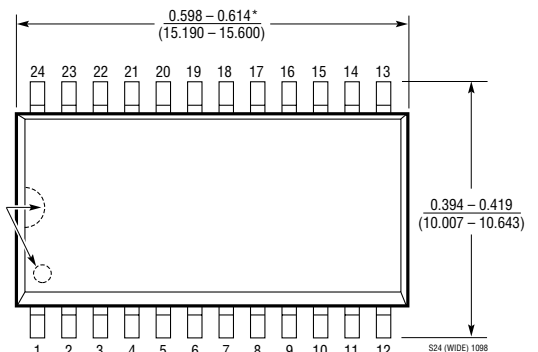
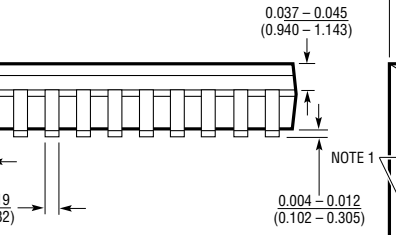
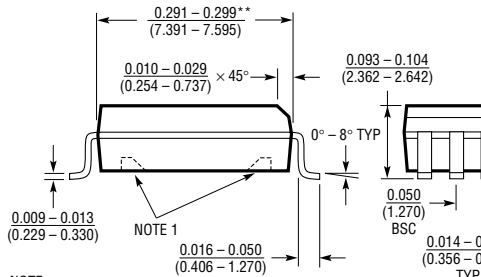

NOTE:  
 1. PIN 1 IDENT. NOTCH ON TOP AND CAVITIES ON THE BOTTOM OF PACKAGES ARE THE MANUFACTURING OPTIONS. THE PART MAY BE SUPPLIED WITH OR WITHOUT ANY OF THE OPTIONS  
 \*DIMENSION DOES NOT INCLUDE MOLD FLASH. MOLD FLASH SHALL NOT EXCEED 0.006" (0.152mm) PER SIDE  
 \*\*DIMENSION DOES NOT INCLUDE INTERLEAD FLASH. INTERLEAD FLASH SHALL NOT EXCEED 0.010" (0.254mm) PER SIDE

# LTC1421/LTC1421-2.5

## TYPICAL APPLICATION

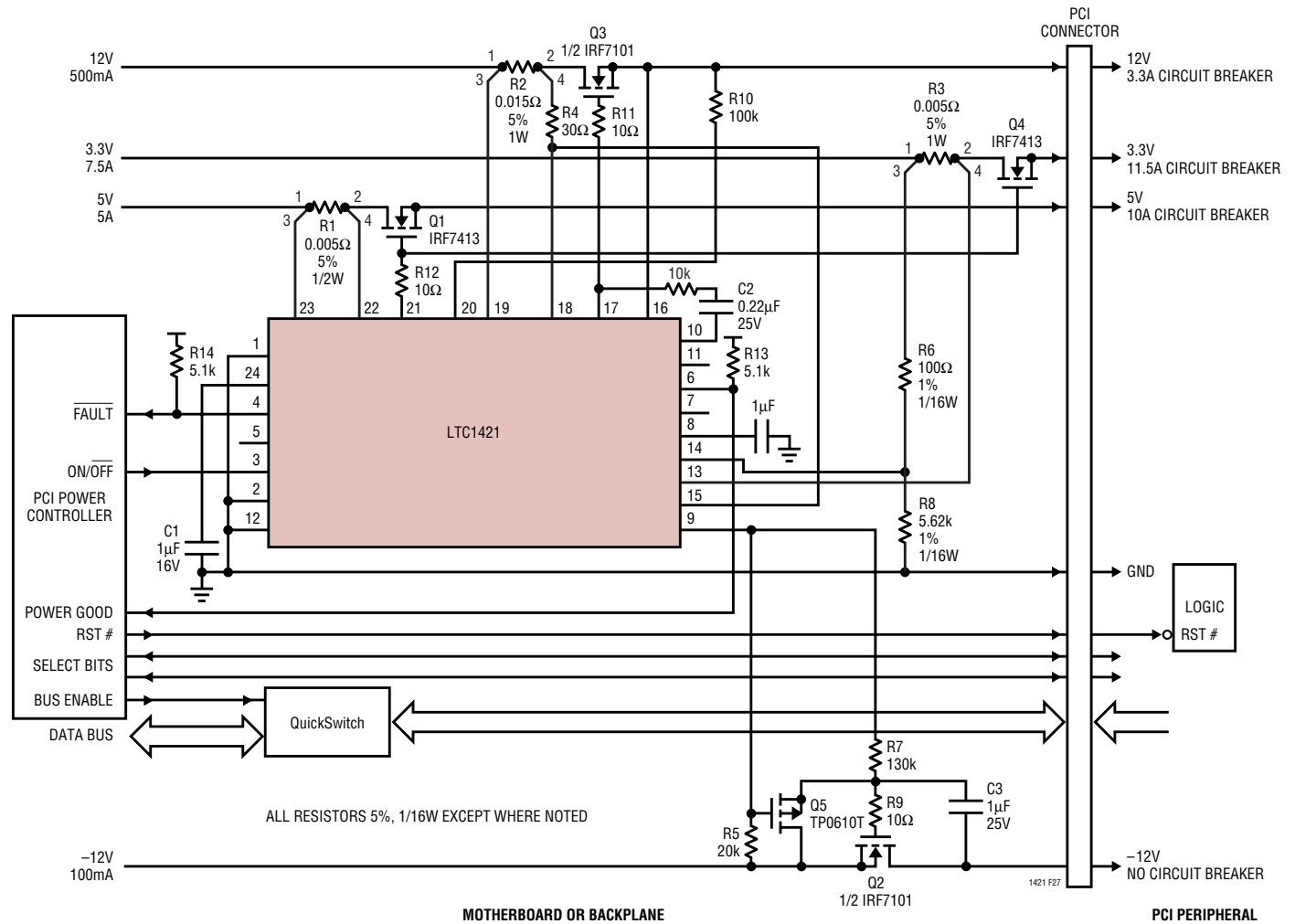

Figure 27. PCI Power Controller

## RELATED PARTS

PART NUMBER	DESCRIPTION	COMMENTS
LTC1155	Dual High Side Switch Driver	Short-Circuit Protection and Micropower Standby Operation
LTC1422	Hot Swap Controller in SO-8	System Reset Output with Programmable Delay
LTC1477/LTC1478	Single and Dual Protected High Side Switches	Inrush Current Limited, Built-In 2A Short-Circuit Protection
LT1640L/LT1640H	Negative Voltage Hot Swap Controller in SO-8	Operates from -10V to -80V
LT1641	High Voltage Hot Swap Controller in SO-8	Operates from 9V to 80V
LTC1642	Fault Protected Hot Swap Controller	Operates Up to 16.5V, Protected to 33V
LTC1643L/LTC1643H	PCI-Bus Hot Swap Controller	3.3V, 5V and ±12V in Narrow 16-Pin SSOP
LTC1645	2-Channel Hot Swap Controller	Operates from 1.2V to 12V, Power Sequencing
LTC1647	Dual Hot Swap Controller	Dual ON Pins for Supplies from 3V to 15V

Компания «Океан Электроники» предлагает заключение долгосрочных отношений при поставках импортных электронных компонентов на взаимовыгодных условиях!

Наши преимущества:

- Поставка оригинальных импортных электронных компонентов напрямую с производств Америки, Европы и Азии, а так же с крупнейших складов мира;
- Широкая линейка поставок активных и пассивных импортных электронных компонентов (более 30 млн. наименований);
- Поставка сложных, дефицитных, либо снятых с производства позиций;
- Оперативные сроки поставки под заказ (от 5 рабочих дней);
- Экспресс доставка в любую точку России;
- Помощь Конструкторского Отдела и консультации квалифицированных инженеров;
- Техническая поддержка проекта, помощь в подборе аналогов, поставка прототипов;
- Поставка электронных компонентов под контролем ВП;
- Система менеджмента качества сертифицирована по Международному стандарту ISO 9001;
- При необходимости вся продукция военного и аэрокосмического назначения проходит испытания и сертификацию в лаборатории (по согласованию с заказчиком);
- Поставка специализированных компонентов военного и аэрокосмического уровня качества (Xilinx, Altera, Analog Devices, Intersil, Interpoint, Microsemi, Actel, Aeroflex, Peregrine, VPT, Syfer, Eurofarad, Texas Instruments, MS Kennedy, Miteq, Cobham, E2V, MA-COM, Hittite, Mini-Circuits, General Dynamics и др.);

Компания «Океан Электроники» является официальным дистрибьютором и эксклюзивным представителем в России одного из крупнейших производителей разъемов военного и аэрокосмического назначения «JONHON», а так же официальным дистрибьютором и эксклюзивным представителем в России производителя высокотехнологичных и надежных решений для передачи СВЧ сигналов «FORSTAR».



## JONHON

«JONHON» (основан в 1970 г.)

Разъемы специального, военного и аэрокосмического назначения:

(Применяются в военной, авиационной, аэрокосмической, морской, железнодорожной, горно- и нефтедобывающей отраслях промышленности)

«FORSTAR» (основан в 1998 г.)

ВЧ соединители, коаксиальные кабели, кабельные сборки и микроволновые компоненты:

(Применяются в телекоммуникациях гражданского и специального назначения, в средствах связи, РЛС, а так же военной, авиационной и аэрокосмической отраслях промышленности).



Телефон: 8 (812) 309-75-97 (многоканальный)

Факс: 8 (812) 320-03-32

Электронная почта: [ocean@oceanchips.ru](mailto:ocean@oceanchips.ru)

Web: <http://oceanchips.ru/>

Адрес: 198099, г. Санкт-Петербург, ул. Калинина, д. 2, корп. 4, лит. А