

300 MHz/450 MHz/600 MHz, MCU with Arm Cortex<sup>®</sup>-R4 and -M3\*1, on-chip FPU, 498/747/996 DMIPS, up to 1 Mbyte of on-chip extended SRAM, Ethernet MAC, EtherCAT\*1, USB 2.0 high-speed, CAN, various communications interfaces such as an SPI multi-I/O bus controller,  $\Delta\Sigma$  interface, safety functions, encoder interfaces\*1, and security functions\*1

## Features

### ■ On-chip 32-bit Arm Cortex-R4 processor

- High-speed realtime control with maximum operating frequency of 300/450/600 MHz
- Capable of 498/747/996 DMIPS (in operation at 300/450/600 MHz)
- On-chip 32-bit Arm Cortex-R4 (revision r1p4)
- Tightly coupled memory (TCM) with ECC: 512 Kbytes/32 Kbytes
- Instruction cache/data cache with ECC: 8 Kbytes per cache
- High-speed interrupt
- The FPU supports addition, subtraction, multiplication, division, multiply-and-accumulate, and square-root operations at single-precision and double-precision.
- Harvard architecture with 8-stage pipeline
- Supports the memory protection unit (MPU)
- Arm CoreSight architecture, includes support for debugging through JTAG and SWD interfaces

### ■ On-chip 32-bit Arm Cortex-M3 processor (in products incorporating an R-IN engine)

- 150-MHz operating frequency
- On-chip 32-bit Arm Cortex-M3 (revision r2p1)
- RISC Harvard architecture with 3-stage pipeline
- Supports the memory protection unit (MPU)

### ■ Low power consumption

- Standby mode, sleep mode, and module stop function

### ■ On-chip extended SRAM

- Up to 1 Mbyte of the on-chip extended SRAM with ECC
- 150 MHz

### ■ Data transfer

- DMAC: 16 channels  $\times$  2 units
- DMAC for the Ethernet controller: 1 channel

### ■ Event link controller

- Module operations can be started by event signals rather than by interrupt handlers.
- Linked operation of modules is available even while the CPU is in the sleep state.

### ■ Reset and power supply voltage control

- Four reset sources including a pin reset
- Dual power-voltage configuration: 3.3 V (I/O unit), 1.2 V (internal)

### ■ Clock functions

- External clock/oscillator input frequency: 25 MHz
- CPU clock frequency: Up to 300/450/600 MHz
- Low-speed on-chip oscillator (LOCO): 240 kHz

### ■ Independent watchdog timer

- Operated by a clock signal obtained by frequency-dividing the clock signal from the low-speed on-chip oscillator: Up to 120 kHz

### ■ Safety functions

- Register write protection, input clock oscillation stop detection, CRC, IWDtA, and A/D self-diagnosis
- An error control module is incorporated to generate a pin signal output, interrupt, or internal reset in response to errors originating in the various modules.

### ■ Security functions (optional)\*2

- Boot mode with security through encryption

### ■ Encoder interfaces (optional)\*3

- 2 channels\*4
- EnDat 2.2, BiSS-C, FA-CODER, A-format, and HIPERFACE DSL-compliant interfaces\*5
- Frequency-divided output from an encoder

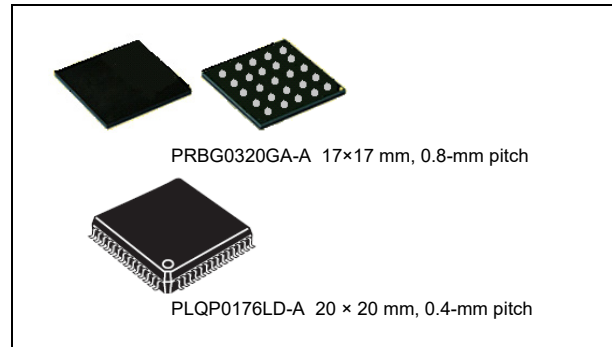

### ■ Various communications interfaces

- Ethernet
  - EtherCAT slave controller: 2 ports (optional)
  - Ethernet MAC: 1 port (an Ethernet switch is not used) or
  - Ethernet MAC: 1 port (an Ethernet switch to support 2 ports is used)
- USB 2.0 high-speed host/function : 1 channel
- CAN (compliant with ISO11898-1): 2 channels (max.)
- SCIFA with 16-byte transmission and reception FIFOs: 5 channels
- I<sup>2</sup>C bus interface: 2 channels for transfer at up to 400 kbps
- RSPiA: 4 channels
- SPIBSC: Provides a single interface for multi-I/O compatible serial flash memory

### ■ External address space

- Buses for high-speed data transfer at 75 MHz (max.)
- Support for up to 6 CS areas
- 8-, 16-, or 32-bit bus space is selectable per area

### ■ Up to 33 extended-function timers

- 16-bit TPUa (12 channels), MTU3a (9 channels), GPTa (4 channels): Input capture, output compare, PWM waveform output
- 16-bit CMT (6 channels), 32-bit CMTW (2 channels)

### ■ Serial sound interface (1 channel)

### ■ $\Delta\Sigma$ interface

- Up to 4  $\Delta\Sigma$  modulators are connectable externally.

### ■ 12-bit A/D converters

- 12 bits  $\times$  2 units (max.) (8 channels for unit 0; 16 channels for unit 1)
- Self diagnosis
- Detection of analog input disconnection

### ■ Temperature sensor for measuring temperature within the chip

### ■ General-purpose I/O ports

- 5-V tolerance, open drain, input pull-up

### ■ Multi-function pin controller

- The locations of input/output functions for peripheral modules are selectable from among multiple pins.

### ■ Operating temperature range

- T<sub>j</sub> = -40°C to +125°C
- T<sub>j</sub>: Junction temperature

Note 1. Optional

Note 2. Details of these optional functions will only be disclosed after completion of a binding non-disclosure agreement. For details, contact our sales representative.

Note 3. For details, contact our sales representative.

Note 4. For use of two channels, use them in combination of any two protocols among EnDat2.2, BiSS-C, FA-CODER, and A-format.

Note 5. BiSS is a registered trademark of iC-Haus GmbH.

## 1. Overview

### 1.1 Outline of Specifications

This LSI circuit is a high-performance MCU equipped with the Arm Cortex<sup>®</sup>-R4 processor with FPU and Cortex-M3 processor (for products incorporating an R-IN engine), and incorporating integrated peripheral functions necessary for system configuration. Table 1.1 lists the specifications in outline, and Table 1.2 gives a comparison of the functions of products in different packages

Table 1.1 shows the outline of maximum specifications, and the number of peripheral module channels differs depending on the pin number on the package. For details, see Table 1.2, List of Functions.

**Table 1.1 Outline of Specifications (1 / 7)**

Classification	Module/Function	Description
CPU	Central processing unit (Cortex-R4)	<ul style="list-style-type: none"> <li>Maximum operating frequency 320-pin FBGA: 300 MHz/450 MHz/600 MHz 176-pin HLQFP: 450 MHz</li> <li>32-bit CPU Cortex-R4 designed by Arm (core revision r1p4)</li> <li>Address space: 4 Gbytes</li> <li>Instruction cache: 8 Kbytes (with ECC)</li> <li>Data cache: 8 Kbytes (with ECC)</li> <li>Tightly coupled memory (TCM) ATCM: 512 Kbytes (with ECC) BTCM: 32 Kbytes (with ECC)</li> <li>Instruction set: Arm v7-R architecture, so support includes Thumb<sup>®</sup> and Thumb-2</li> <li>Data arrangement Instructions: Little endian Data: Little endian</li> <li>Memory protection unit (MPU)</li> </ul>
	Central processing unit (Cortex-M3) (for products incorporating an R-IN engine)	<ul style="list-style-type: none"> <li>Operating frequency: 150 MHz</li> <li>32-bit CPU Cortex-M3 designed by Arm (core revision r2p1)</li> <li>Address space: 4 Gbytes</li> <li>Instruction set: Arm v7-M architecture, so support includes Thumb<sup>®</sup> and Thumb-2</li> <li>Data arrangement Instructions: Little endian Data: Little endian</li> <li>Memory protection unit (MPU)</li> </ul>
	FPU (Cortex-R4)	<ul style="list-style-type: none"> <li>Supports addition, subtraction, multiplication, division, multiply-and-accumulate, and square-root operations at single- and double-precision.</li> <li>Registers 32-bit single-word registers: 32 bits × 32 (can be used as 16 double-word registers: 64 bits × 16)</li> </ul>
Memory	On-chip extended SRAM with ECC	<ul style="list-style-type: none"> <li>Capacity: Up to 1 Mbyte</li> <li>Operating frequency: 150 MHz</li> <li>SEC-DED (single error correction/double error detection)</li> </ul>
Operating modes		<ul style="list-style-type: none"> <li>The operating mode can be selected from the following three boot modes SPI boot mode (for booting up from serial flash memory) 16-bit bus boot mode (NOR Flash) 32-bit bus boot mode (NOR Flash)</li> </ul>
Clock	Clock generation circuit	<ul style="list-style-type: none"> <li>The input clock can be selected from an external clock or external resonator.</li> <li>Detection of input clock oscillation stopping</li> <li>The following clocks are generated. CPU clock: 300/450/600 MHz (max.) System clock: 150 MHz (fixed) High-speed peripheral module clock: 150 MHz (fixed) Low-speed peripheral module clock: 75 MHz (fixed) ADCCLK in the 12-bit A/D converter (S12ADCa): 60 MHz (max.) External bus clock: 75 MHz (max.) Low-speed on-chip oscillator: 240 kHz (fixed)</li> </ul>
Reset		RES# pin reset, error control module (ECM) reset, software reset

**Table 1.1 Outline of Specifications (2 / 7)**

Classification	Module/Function	Description
Low power	Low-power consumption function	<ul style="list-style-type: none"> <li>Standby mode (Cortex-R4)</li> <li>Sleep mode (Cortex-M3) (for products incorporating an R-IN engine)</li> <li>Module stop function</li> </ul>
Interrupt	Cortex-R4 vector interrupt controller (VIC)	<ul style="list-style-type: none"> <li>Peripheral function interrupts: 273 sources / 276 sources (for products incorporating an R-IN engine)</li> <li>External interrupts: 20 sources (NMI, IRQ0 to IRQ15, ETH0_INT, ETH1_INT, and ETH2_INT pins)</li> <li>Software interrupts: 1 source</li> <li>Non-maskable interrupts: 2 sources</li> <li>Sixteen levels specifiable for the order of priority</li> </ul>
	Cortex-M3 nested-type vector interrupt controller (NVIC) (only included in products incorporating an R-IN engine)	<ul style="list-style-type: none"> <li>Peripheral function interrupts: 82 sources</li> <li>External interrupts: 19 sources (IRQ0 to IRQ15, ETH0_INT, ETH1_INT, and ETH2_INT pins)</li> <li>Software interrupts: 1 source</li> <li>Non-maskable interrupts: 1 source</li> <li>Sixteen levels specifiable for the order of priority</li> </ul>
External bus extension	Bus state controller (BSC)	<ul style="list-style-type: none"> <li>The external address space is divided into six areas (CS0 to CS5) for management.</li> <li>The following features settable for each area independently. <ul style="list-style-type: none"> <li>Bus size (8, 16, or 32 bits): Available sizes depend on the area.</li> <li>Number of access wait cycles (different wait cycles can be specified for read and write access cycles in some areas)</li> <li>Idle wait cycle insertion (between same area access cycles or different area access cycles)</li> <li>Specifying the memory to be connected to each area enables direct connection to SRAM, SRAM with byte selection, SDRAM, and burst ROM (clocked synchronous or asynchronous). The address/data multiplexed I/O (MPX) interface is also available.</li> </ul> </li> <li>Outputs a chip select signal (CS0# to CS5#) according to the target area (CS assert or negate timing can be selected by software)</li> <li>SDRAM refresh <ul style="list-style-type: none"> <li>Auto refresh or self-refresh mode selectable</li> </ul> </li> <li>SDRAM burst access</li> </ul>
Data transfer	Direct memory access controller (DMAC)	<ul style="list-style-type: none"> <li>2 units (16 channels for unit 0, 16 channels for unit 1)</li> <li>Transfer modes: Single transfer mode and block transfer mode</li> <li>Transfer size <ul style="list-style-type: none"> <li>Unit 0: 1/2/4/16/32/64 bytes</li> <li>Unit 1: 1/2/4/16 bytes</li> </ul> </li> <li>Activation sources: External requests (DREQ0 to DREQ2), external interrupts, on-chip peripheral module requests, and software requests</li> </ul>
I/O ports	General-purpose I/O ports	<ul style="list-style-type: none"> <li>320-pin FBGA <ul style="list-style-type: none"> <li>I/O pins: 209</li> <li>Input pins: 9</li> <li>Pull-up/pull-down resistors: 209</li> <li>5-V tolerance: 9</li> </ul> </li> <li>176-pin HLQFP <ul style="list-style-type: none"> <li>I/O pins: 97</li> <li>Input pins: 5</li> <li>Pull-up/pull-down resistors: 97</li> <li>5-V tolerance: 5</li> </ul> </li> </ul>
Event link controller (ELC)		<ul style="list-style-type: none"> <li>Up to 103 event signals can be interlinked with the operation of modules.</li> <li>In particular, the operation of timer modules can be started by input event signals.</li> <li>Event-linked operation of signals of ports B and E is to be possible.</li> </ul>
Multi-function pin controller (MPC)		The locations of input/output functions are selectable from among multiple pins.

**Table 1.1 Outline of Specifications (3 / 7)**

Classification	Module/Function	Description
Timers	16-bit timer pulse unit (TPUa)	<ul style="list-style-type: none"> <li>• (16 bits × 6 channels) × 2 units*2</li> <li>• Maximum 16 lines of pulse input/output × 2 units</li> <li>• Select from among seven or eight counter-input clock signals for each channel (with maximum operating frequency of 75 MHz)</li> <li>• Input capture/output compare function</li> <li>• Counter clear operation (synchronous clearing by compare match/input capture)</li> <li>• Simultaneous writing to multiple timer counters (TCNT)</li> <li>• Simultaneous register input/output by synchronous counter operation</li> <li>• Output of PWM waveforms in up to 15 phases × 2 units in PWM mode</li> <li>• Support for buffered operation, phase-counting mode (two phase encoder input) and cascade-connected operation (32 bits × 4 channels) depending on the channel.</li> <li>• PPG output trigger can be generated (unit 0 only)</li> <li>• Capable of generating conversion start triggers for the A/D converters</li> <li>• Digital noise filtering of signals from the input capture pins</li> <li>• Event linking by the ELC (unit 0 only)</li> </ul>
	Multifunction timer pulse unit (MTU3a)	<ul style="list-style-type: none"> <li>• 9 channels (16 bits × 8 channels, 32 bits × 1 channel)</li> <li>• Maximum of 28 pulse-input/output and 3 pulse-input possible</li> <li>• Select from among 10, 11, 12 or 14 counter-input clock signals for each channel (with maximum operating frequency of 150 MHz)</li> <li>• Input capture function</li> <li>• 39 output compare/input capture registers</li> <li>• Counter clear operation (synchronous clearing by compare match/input capture)</li> <li>• Simultaneous writing to multiple timer counters (TCNT)</li> <li>• Simultaneous register input/output by synchronous counter operation</li> <li>• Buffered operation</li> <li>• Support for cascade-connected operation</li> <li>• Pulse output mode <ul style="list-style-type: none"> <li>Toggle/PWM/complementary PWM/reset-synchronized PWM</li> </ul> </li> <li>• Complementary PWM output mode <ul style="list-style-type: none"> <li>Outputs non-overlapping waveforms for controlling 3-phase inverters</li> <li>Automatic specification of dead times</li> <li>PWM duty cycle: Selectable as any value from 0% to 100%</li> <li>Delay can be applied to requests for A/D conversion.</li> <li>Non-generation of interrupt requests at crest or trough values of counters can be selected.</li> <li>Double buffer configuration</li> </ul> </li> <li>• Reset synchronous PWM mode <ul style="list-style-type: none"> <li>Three phases of positive and negative PWM waveforms can be output with desired duty cycles.</li> </ul> </li> <li>• Phase-counting mode: 16-bit mode (channels 1 and 2); 32-bit mode (channels 1 and 2 in cascade connection)</li> <li>• Counter functionality for dead-time compensation</li> <li>• Generation of triggers for A/D converter conversion</li> <li>• A/D converter start triggers can be skipped</li> <li>• Digital noise filter function for signals on the input capture and external counter clock pins</li> <li>• PPG output trigger can be generated</li> <li>• Event linking by the ELC</li> </ul>

**Table 1.1 Outline of Specifications (4 / 7)**

Classification	Module/Function	Description
Timers	General PWM timer (GPTa)	<ul style="list-style-type: none"> <li>• 16 bits × 4 channels</li> <li>• Counting up or down (saw-wave), counting up and down (triangle-wave) selectable for all channels</li> <li>• Select from among four counter-input clock signals for each channel (with maximum operating frequency of 150 MHz)</li> <li>• 2 input/output pins per channel</li> <li>• 2 output compare/input capture registers per channel</li> <li>• For the 2 output compare/input capture registers of each channel, 4 registers are provided as buffer registers and are capable of operating as compare registers when buffering is not in use.</li> <li>• In output compare operation, buffer switching can be at crests or troughs, enabling the generation of laterally asymmetrically PWM waveforms.</li> <li>• Registers for setting up frame intervals on each channel (with capability for generating interrupts on overflow or underflow)</li> <li>• Synchronizable operation of the several counters</li> <li>• Modes of synchronized operation (synchronized, or displaced by desired times for phase shifting)</li> <li>• Generation of dead times in PWM operation</li> <li>• Through combination of three counters, generation of automatic three-phase PWM waveforms incorporating dead times</li> <li>• Starting, clearing, and stopping counters in response to external or internal triggers</li> <li>• Internal trigger sources: software, and compare-match</li> <li>• Generation of triggers for A/D converter conversion</li> <li>• Digital noise filter function for signals on the input capture and external trigger pins</li> <li>• Event linking by the ELC</li> </ul>
	Programmable pulse generator (PPG)	<ul style="list-style-type: none"> <li>• (4 bits × 4 groups) × 2 units*1</li> <li>• Pulse output with the MTU3a or TPUa output as a trigger</li> <li>• Maximum of 32 pulse-output possible</li> </ul>
	Compare match timer (CMT)	<ul style="list-style-type: none"> <li>• (16 bits × 2 channels) × 3 units</li> <li>• Select from among four counter-input clock signals for each channel (with maximum operating frequency of 75 MHz)</li> <li>• Event linking by the ELC (channel 1 of unit 0 only)</li> </ul>
	Compare match timer W (CMTW)	<ul style="list-style-type: none"> <li>• (32 bits × 1 channel) × 2 units</li> <li>• Compare-match, input-capture input, and output-comparison output are available.</li> <li>• Select from among four counter-input clock signals for each channel (with maximum operating frequency of 75 MHz)</li> <li>• Interrupt requests can be output in response to compare-match, input-capture, and output-comparison events.</li> <li>• Digital noise filter function for signals on the input capture pins</li> <li>• Event linking by the ELC</li> </ul>
	Watchdog timer (WDTA)	<ul style="list-style-type: none"> <li>• 14 bits × 1 channel Products incorporating an R-IN engine: 14 bits × 2 channels</li> <li>• Select from among six counter-input clock signals for each channel (with maximum operating frequency of 75 MHz)</li> </ul>
	Independent watchdog timer (IWDTa)	<ul style="list-style-type: none"> <li>• 14 bits × 1 channel</li> <li>• Counter-input clock: Low-speed on-chip oscillator (LOCO)/2 Dedicated clock/1, dedicated clock/16, dedicated clock/32, dedicated clock/64, dedicated clock/128, dedicated clock/256 (with maximum operating frequency of 120 MHz)</li> </ul>
	Port output enable 3 (POE3)	<ul style="list-style-type: none"> <li>• Control of the high-impedance state of the MTU3a / GPTa's waveform output pins</li> <li>• Initiation by inputs on 4 pins, POE0#, POE4#, POE8#, and POE10#</li> <li>• Initiation on detection of short-circuited outputs (detection of simultaneous PWM output to the active level)</li> <li>• Initiation by input clock oscillation-stoppage detection, PLL oscillation abnormality detection, or software</li> <li>• Additional programming of output control target pins is enabled</li> </ul>

**Table 1.1 Outline of Specifications (5 / 7)**

Classification	Module/Function	Description
Communication function	Ethernet MAC (ETHERC)	<ul style="list-style-type: none"> <li>• 1 port (Use of two ports is possible with the Ethernet switch function)</li> <li>• IEEE802.3 is supported</li> <li>• 10BASE and 100BASE are supported</li> <li>• Full duplex and half duplex are supported</li> <li>• Automatic pause packet transmission function</li> <li>• Auto broadcast suspension function by the pause packet reception</li> <li>• MII/RMII interface is supported</li> </ul>
	Ethernet switch	<ul style="list-style-type: none"> <li>• 2-port PHY interfaces</li> <li>• IEEE802.3</li> <li>• 10BASE and 100BASE are supported</li> <li>• Full and half duplex</li> <li>• Hardware switching, lookup, and filtering</li> <li>• QoS with frame prioritization</li> <li>• Priority control based on VLAN Priority (IEEE802.1q), which enables priority reassignment</li> <li>• Classification and priority assignment based on IPv4 DiffServ Code Point Field, IPv6 Class of Service</li> <li>• Queue with four priority levels</li> <li>• Multicasting and broadcasting</li> <li>• VLAN frame</li> <li>• IEEE1588 timer module</li> <li>• Cut-through and hub features</li> <li>• Device level ring (DLR)</li> </ul>
	EtherCAT Slave Controller (ECATC) *2	<ul style="list-style-type: none"> <li>• 1 channel (2 ports) *3</li> <li>• EtherCAT Slave Controller IP core (made by Beckhoff Automation GmbH) implemented</li> </ul>
	USB 2.0 HS host/function module	<ul style="list-style-type: none"> <li>• 1 port</li> <li>• Compliance with the USB 2.0 specification</li> <li>• Transfer rate High speed (480 Mbps), full speed (12 Mbps)</li> <li>• Communications buffer Incorporates 1 Kbyte of RAM for host mode Incorporates 8 Kbytes of RAM for function mode</li> </ul>
	Serial communication interface with FIFO (SCIFA)	<ul style="list-style-type: none"> <li>• 5 channels</li> <li>• Serial communications modes: Asynchronous, clock synchronous</li> <li>• On-chip baud rate generator allows selection of the desired bit rate</li> <li>• Choice of LSB-first or MSB-first transfer</li> <li>• Both the transmission and reception sections are equipped with 16-byte FIFO buffers, allowing continuous transmission and reception.</li> <li>• Bit rate modulation</li> </ul>
	I <sup>2</sup> C bus interface (RIICa)	<ul style="list-style-type: none"> <li>• 2 channels</li> <li>• Supports I<sup>2</sup>C bus format</li> <li>• Supports the multi-master</li> <li>• Max. transfer rate: 400 kbps</li> <li>• Event linking by the ELC</li> </ul>
	CAN module (RSCAN)	<ul style="list-style-type: none"> <li>• 2 channels</li> <li>• Compliance with the ISO11898-1 specification (standard frame and extended frame)</li> <li>• Message buffers Max. 64 × 2 channels of reception message buffers, which are used by all channels 16 transmission message buffers per channel</li> <li>• Max. transfer rate: 1 Mbps</li> </ul>

**Table 1.1 Outline of Specifications (6 / 7)**

Classification	Module/Function	Description
Communication function	Serial peripheral interface (RSPiA)	<ul style="list-style-type: none"> <li>• 4 channels</li> <li>• RSPi transfer facility Using the MOSI (master out slave in), MISO (master in slave out), SSL (slave select), and RSPCK (RSPi clock) signals enables serial transfer through SPI operation (four lines) or clock-synchronous operation (three lines) Capable of handling serial transfer as a master or slave</li> <li>• Data formats Switching between MSB first and LSB first The number of bits in each transfer can be changed to any number of bits from 8 to 16, or 20, 24, or 32 bits. 128-bit buffers for transmission and reception Up to four frames can be transmitted or received in a single transfer operation (with each frame having up to 32 bits)</li> <li>• Buffered structure Double buffers for both transmission and reception</li> <li>• RSPCK can be stopped automatically with the reception buffer full for master reception</li> <li>• Event linking by the ELC</li> </ul>
	SPI multi I/O bus controller (SPIBSC)	<ul style="list-style-type: none"> <li>• 1 channel</li> <li>• One serial flash memory with multiple I/O bus sizes (single/dual/quad) can be connected.</li> <li>• External address space read mode (built-in read cache)</li> <li>• SPI operating mode</li> <li>• Clock polarity and clock phase can be selected.</li> <li>• Maximum transfer rate: 300 Mbps (for quad)</li> </ul>
	Serial sound interface (SSI)	<ul style="list-style-type: none"> <li>• 1 channel</li> <li>• Duplex communication</li> <li>• Support of various serial audio formats</li> <li>• Support of master and slave functions</li> <li>• Generation of serial bit clock</li> <li>• Support of 8, 16, 18, 20, 22, 24, and 32-bit data formats</li> <li>• Support of eight-stage FIFO for transmission and reception</li> <li>• Support of WS continue mode in which the SSIWS signal is not stopped.</li> </ul>
	$\Delta\Sigma$ interface (DSMIF)	<ul style="list-style-type: none"> <li>• 4 channels (unit 0: 3 channels, unit 1: 1 channel)</li> <li>• Up to 4 <math>\Delta\Sigma</math> modulators are externally connectable</li> <li>• Sync filter can be selected as first, second, or third order</li> </ul>
	12-bit A/D converter (S12ADCa)	<ul style="list-style-type: none"> <li>• 12 bits <math>\times</math> 2 units (unit 0: 8 channels, unit 1: 16 channels)*1</li> <li>• 12-bit resolution</li> <li>• Conversion time Unit 0: 0.483 <math>\mu</math>s per channel Unit 1: 0.883 <math>\mu</math>s per channel</li> <li>• Operating mode Scan mode (single scan mode, continuous scan mode, or group scan mode) Group A priority control (only for group scan mode)</li> <li>• Sample-and-hold function Common sample-and-hold circuit included In addition, channel-dedicated sample-and-hold function (4 channels: in unit 0 only) included</li> <li>• Sampling variable Sampling time can be set up for each channel</li> <li>• Self-diagnostic function The self-diagnostic function internally generates three analog input voltages (unit 0: VREFL0, VREFH0 <math>\times</math> 1/2, VREFH0; unit 1: VREFL1, VREFH1 <math>\times</math> 1/2, VREFH1)</li> <li>• Double trigger mode (A/D conversion data duplicated)</li> <li>• Detection of analog input disconnection</li> <li>• Three ways to start A/D conversion Software trigger, timer (MTU3a, GPTa, TPUa) trigger, external trigger</li> <li>• Event linking by the ELC</li> </ul>
	Temperature sensor	<ul style="list-style-type: none"> <li>• 1 channel</li> <li>• Relative precision: <math>\pm 1^\circ\text{C}</math></li> <li>• The voltage of the temperature is converted into a digital value by the 12-bit A/D converter (unit 0).</li> </ul>

**Table 1.1 Outline of Specifications (7 / 7)**

Classification	Module/Function	Description
Safety	Register write protection function	Protects important registers from being overwritten in cases where a program runs out of control.
	CRC calculator (CRC)	<ul style="list-style-type: none"> <li>• CRC code generation for arbitrary amounts of data in 8-, 16-, or 32-bit units</li> <li>• Select any of four generating polynomials:  <math>X^{32} + X^{26} + X^{23} + X^{22} + X^{16} + X^{12} + X^{11} + X^{10} + X^8 + X^7 + X^5 + X^4 + X^2 + X + 1</math> (32-Ethernet),  <math>X^{16} + X^{12} + X^5 + 1</math> (16-CCITT),  <math>X^8 + X^4 + X^3 + X^2 + 1</math> (8-SAEJ1850),  <math>X^8 + X^5 + X^3 + X^2 + X + 1</math> (8-0x2F)</li> </ul>
	Input clock oscillation stop function	Input clock oscillation stop detection: Available
	Clock monitor circuit (CLMA)	Monitors the abnormal output clock frequency from the PLL circuit or low-speed on-chip oscillator.
	Data operation circuit (DOC)	The function to compare, add, or subtract 16-bit data
	Error control module (ECM)	<ul style="list-style-type: none"> <li>• Generates an interrupt, internal reset, or error output for the error signal input from each module.</li> <li>• Time-out function</li> <li>• The error control is duplicated in the master and the checker.</li> </ul>
Security	Secure boot mode <sup>4</sup>	As an option, a boot mode with encryption as a security function is available.
Encoder interfaces <sup>5</sup>		<ul style="list-style-type: none"> <li>• 2 channels<sup>6</sup></li> <li>• EnDat 2.2, BiSS-C, FA-CODER, A-format, and HIPERFACE DSL-compliant interfaces</li> <li>• Frequency-divided output from an encoder</li> </ul>
Power supply voltage		VDD = PLLVDD0 = PLLVDD1 = DVDD_USB = 1.14 to 1.26 V VCCQ33 = AVCC0 = AVCC1 = VREFH0 = VREFH1 = VDD33_USB = 3.0 to 3.6 V
Operating temperature		Tj = -40 to +125°C
Package		320-pin FBGA: 17 × 17 mm, 0.8-mm pitch PRBG0320GA-A 176-pin HLQFP: 20 × 20 mm, 0.4-mm pitch PLQP0176LD-A
Debugging interface		<ul style="list-style-type: none"> <li>• CoreSight architecture designed by Arm</li> <li>• Debugging function by the JTAG/SWD interface, and trace function by the trace port/SWV interface</li> </ul>

Note 1. One unit for 176-pin devices (only unit 0 is provided)

Note 2. EtherCAT is a registered trademark of Beckhoff Automation GmbH, Germany. (optional)

Note 3. Not included in 176-pin devices.

Note 4. See Table 1.3, List of Products, for the products that have the secure boot mode. Details of these optional functions will only be disclosed after completion of a binding non-disclosure agreement. For details, contact our sales representative.

Note 5. This applies to the devices with the encoder interfaces. For details, contact our sales representative.

Note 6. For use of two channels, use them in combination of any two protocols among EnDat2.2, BiSS-C, FA-CODER, and A-format.



**Table 1.2 Comparison of Functions for Different Packages**

Module/Function		RZ/T1 Group		
		320 Pins		176 Pins
		R-IN Engine Incorporated	R-IN Engine Not-Incorporated	
External bus	External bus width	32 bits		
Interrupt	External interrupt	NMI, IRQ0 to IRQ15, ETH0_INT, ETH1_INT, ETH2_INT		NMI, IRQ0 to IRQ15, ETH0_INT, ETH1_INT
DMA	DMA controller (DMAC)	ch0 to ch31		
Timers	16-bit timer pulse unit (TPUa)	ch0 to ch11 (Unit 0, Unit 1)		ch0 to ch5 (Unit 0)
	Multi-function timer pulse unit 3 (MTU3a)	ch0 to ch8		
	General-purpose PWM timer (GPTa)	ch0 to ch3		
	Port output enable 3 (POE3)	Available		
	Programmable pulse generator (PPG)	Unit 0, Unit 1		Unit 0
	Compare match timer (CMT)	ch0 to ch5		
	Compare match timer W (CMTW)	ch0, ch1		
	Watchdog timer (WDTA)	ch0, ch1	ch0	
	Independent watchdog timer (IWDTa)	Available		
Communication function	Ethernet controller (ETHERC)	1 port*1		
	EtherCAT slave controller (ECATC)	2 ports*1	2 ports*1 (optional)	Not supported
	USB 2.0 HS host/function module (USB)	ch0		
	Serial communications interface with FIFO (SCIFA)	ch0 to ch4		
	I <sup>2</sup> C bus interface (RIICa)	ch0, ch1		
	Serial peripheral interface (RSPIa)	ch0 to ch3		
	CAN module (RSCAN)	ch0, ch1		
	SPI multi I/O bus controller (SPIBSC)	ch0		
Serial sound interface (SSI)	ch0			
$\Delta\Sigma$ interface (DSMIF)	ch0 to ch3			
12-bit A/D converter (S12ADCa)	AN000 to AN007 (unit 0) AN100 to AN115 (unit 1)		AN000 to AN007 (unit 0)	
Temperature sensor	Available			
CRC calculator (CRC)	Available			
Data operation circuit (DOC)	Available			
Clock monitor circuit (CLMA)	Available			
Secure boot mode*2	Optional			
Event link controller (ELC)	Available			
Encoder interfaces*3	Optional		Not supported	

Note 1. Combining the Ethernet controller and the EtherCAT slave controller (optional) makes a total of three ports. The Ethernet controller can support two ports with the use of the Ethernet switch.

Note 2. See Table 1.3, List of Products for the products that have the secure boot mode. Details of these optional functions will only be disclosed after completion of a binding non-disclosure agreement. For details, contact our sales representative.

Note 3. For details, contact our sales representative.

## 1.2 List of Products

Table 1.3 is a list of products.

**Table 1.3 List of Products (1 / 2)**

Part No.	Package	CPU	On-Chip Extended SRAM Capacity	EtherCAT	Operating Frequency (max.)	Security Function *1	Optional Function
R7S910001CFP	176 pins (PLQP0176LD-A)	Cortex-R4	Not supported	Not supported	450 MHz	Not supported	—
R7S910101CFP	176 pins (PLQP0176LD-A)	Cortex-R4	Not supported	Not supported	450 MHz	Available	—
R7S910002CBG	320 pins (PRBG0320GA-A)	Cortex-R4	Not supported	Not supported	450 MHz	Not supported	—
R7S910102CBG	320 pins (PRBG0320GA-A)	Cortex-R4	Not supported	Not supported	450 MHz	Available	—
R7S910006CBG	320 pins (PRBG0320GA-A)	Cortex-R4	1 Mbyte	Not supported	450 MHz	Not supported	—
R7S910106CBG	320 pins (PRBG0320GA-A)	Cortex-R4	1 Mbyte	Not supported	450 MHz	Available	—
R7S910007CBG	320 pins (PRBG0320GA-A)	Cortex-R4	1 Mbyte	Not supported	600 MHz	Not supported	—
R7S910107CBG	320 pins (PRBG0320GA-A)	Cortex-R4	1 Mbyte	Not supported	600 MHz	Available	—
R7S910011CBG	320 pins (PRBG0320GA-A)	Cortex-R4	Not supported	Not supported	450 MHz	Not supported	Encoder I/F
R7S910111CBG	320 pins (PRBG0320GA-A)	Cortex-R4	Not supported	Not supported	450 MHz	Available	Encoder I/F
R7S910013CBG	320 pins (PRBG0320GA-A)	Cortex-R4	1 Mbyte	Not supported	600 MHz	Not supported	Encoder I/F
R7S910113CBG	320 pins (PRBG0320GA-A)	Cortex-R4	1 Mbyte	Not supported	600 MHz	Available	Encoder I/F
R7S910015CBG	320 pins (PRBG0320GA-A)	Cortex-R4	(1 MB for R- IN Engine)	Supported	450 MHz	Not supported	R-IN Engine (CM3 : 150MHz)
R7S910115CBG	320 pins (PRBG0320GA-A)	Cortex-R4	(1 MB for R- IN Engine)	Supported	450 MHz	Available	R-IN Engine (CM3 : 150MHz)
R7S910016CBG	320 pins (PRBG0320GA-A)	Cortex-R4	(1 MB for R- IN Engine)	Supported	450 MHz	Not supported	Encoder I/F R-IN Engine (CM3 : 150MHz)
R7S910116CBG	320 pins (PRBG0320GA-A)	Cortex-R4	(1 MB for R- IN Engine)	Supported	450 MHz	Available	Encoder I/F R-IN Engine (CM3 : 150MHz)
R7S910017CBG	320 pins (PRBG0320GA-A)	Cortex-R4	(1 MB for R- IN Engine)	Supported	600 MHz	Not supported	R-IN Engine (CM3 : 150MHz)
R7S910117CBG	320 pins (PRBG0320GA-A)	Cortex-R4	(1 MB for R- IN Engine)	Supported	600 MHz	Available	R-IN Engine (CM3 : 150MHz)
R7S910018CBG	320 pins (PRBG0320GA-A)	Cortex-R4	(1 MB for R- IN Engine)	Supported	600 MHz	Not supported	Encoder I/F R-IN Engine (CM3 : 150MHz)

**Table 1.3 List of Products (2 / 2)**

Part No.	Package	CPU	On-Chip Extended SRAM Capacity	EtherCAT	Operating Frequency (max.)	Security Function *1	Optional Function
R7S910118CBG	320 pins (PRBG0320GA-A)	Cortex-R4	(1 MB for R-IN Engine)	Supported	600 MHz	Available	Encoder I/F R-IN Engine (CM3 : 150 MHz)
R7S910025CBG	320 pins (PRBG0320GA-A)	Cortex-R4	1 MB	Supported	450 MHz	Not supported	—
R7S910125CBG	320 pins (PRBG0320GA-A)	Cortex-R4	1 MB	Supported	450 MHz	Available	—
R7S910026CBG	320 pins (PRBG0320GA-A)	Cortex-R4	1 MB	Supported	450 MHz	Not supported	Encoder I/F
R7S910126CBG	320 pins (PRBG0320GA-A)	Cortex-R4	1 MB	Supported	450 MHz	Available	Encoder I/F
R7S910027CBG	320 pins (PRBG0320GA-A)	Cortex-R4	1 MB	Supported	600 MHz	Not supported	—
R7S910127CBG	320 pins (PRBG0320GA-A)	Cortex-R4	1 MB	Supported	600 MHz	Available	—
R7S910028CBG	320 pins (PRBG0320GA-A)	Cortex-R4	1 MB	Supported	600 MHz	Not supported	Encoder I/F
R7S910128CBG	320 pins (PRBG0320GA-A)	Cortex-R4	1 MB	Supported	600 MHz	Available	Encoder I/F
R7S910035CBG	320 pins (PRBG0320GA-A)	Cortex-R4	Not supported	Supported	300 MHz	Not supported	—
R7S910135CBG	320 pins (PRBG0320GA-A)	Cortex-R4	Not supported	Supported	300 MHz	Available	—
R7S910036CBG	320 pins (PRBG0320GA-A)	Cortex-R4	Not supported	Supported	300 MHz	Not supported	Encoder I/F
R7S910136CBG	320 pins (PRBG0320GA-A)	Cortex-R4	Not supported	Supported	300 MHz	Available	Encoder I/F

Note: See the separate documents regarding the encoder I/F.

Note 1. Details of these optional functions will only be disclosed after completion of a binding non-disclosure agreement. For details, contact our sales representative.

### 1.3 Block Diagram

Figure 1.1 shows a block diagram of a 320-pin device.

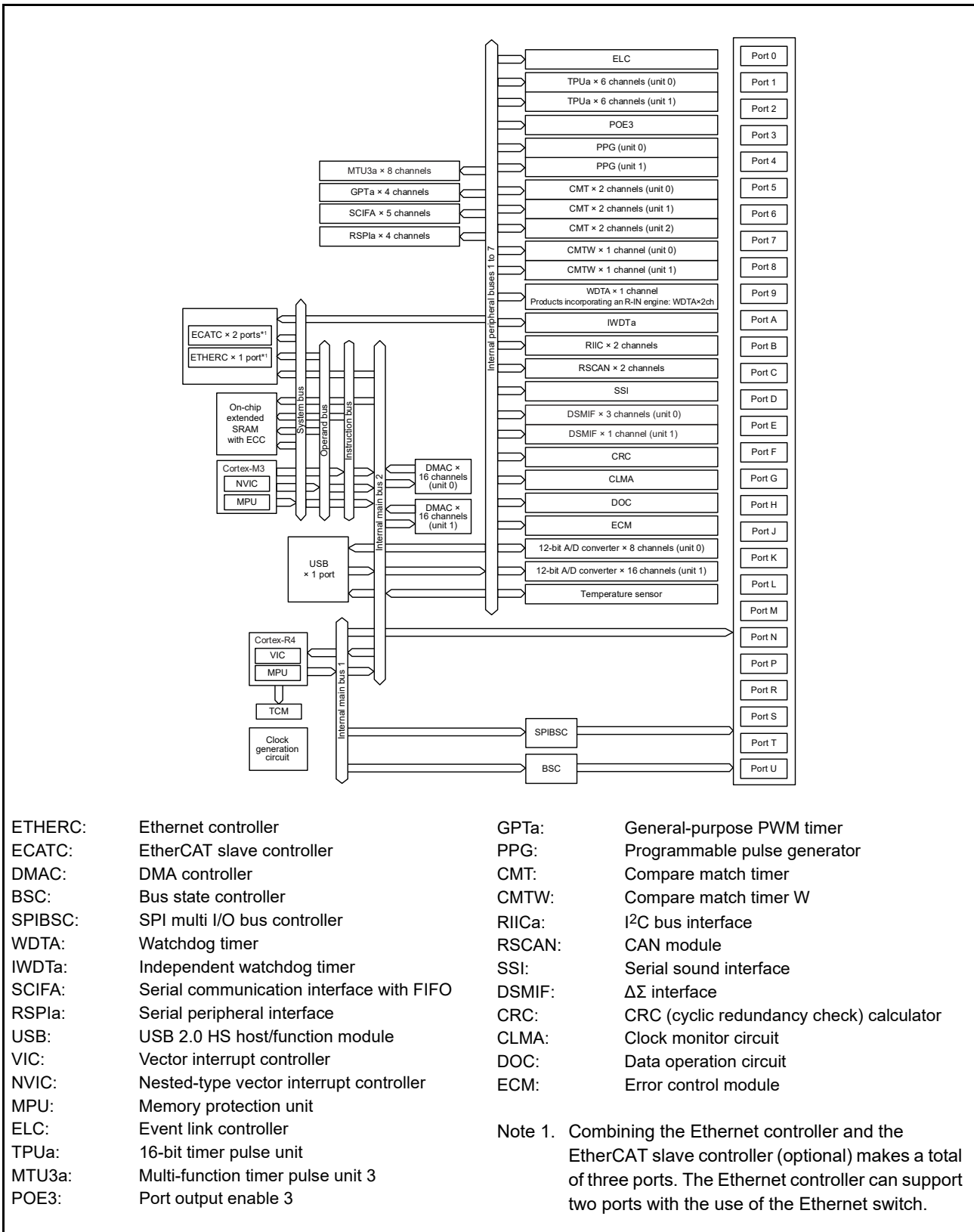

Figure 1.1 Block Diagram

## 1.4 Pin Functions

Table 1.4 lists the pin functions.

**Table 1.4 Pin Functions (1 / 7)**

Classifications	Pin Name	I/O	Description
Power supply	VDD	Input	Power supply pin. Connect this pin to the system power supply.
	VSS	Input	Ground pin. Connect this pin to the system power supply (0 V).
	VCCQ33	Input	Power supply pin for I/O pins
	PLLVDD0, PLLVDD1	Input	Power supply pins for the on-chip PLL oscillator
	PLLVSS0, PLLVSS1	Input	Ground pins for the on-chip PLL oscillator. Connect these pins to the system power supply (0 V).
Clock	XTAL	Output	Connected to a crystal resonator. An external clock signal may also be input to the EXTAL pin.
	EXTAL	Input	
	CKIO	Output	Outputs the external bus clock for external devices.
	AUDIO_CLK	Input	Inputs the external clock for audio.
	CLKOUT25M0, CLKOUT25M1, CLKOUT25M2	Output	Output the external clock for Ethernet PHY.
Operating mode control	MD0 to MD2	Input	Input the operating mode select signal.
System control	RES#	Input	Reset signal input pin. This LSI enters the reset state when this signal goes low.
	BSCANP	Input	Inputs the boundary scan enable signal. Boundary scan is enabled when this pin goes high. When not used, it should be driven low.
	OSCTH	Input	Inputs the clock input mode select signal. When an external clock is input, this pin should be driven high. When a crystal resonator is connected, it should be driven low.
	ERROROUT#	Output	Outputs the error signal from the error control module (ECM).
	RSTOUT#	Output	Outputs the reset signal externally.
Debugging interface	TRST#	Input	Test reset pin for on-chip emulator
	TMS	I/O	Test mode select pin for on-chip emulator
	TDI	Input	Test data input pin for on-chip emulator
	TDO	Output	Test data output pin for on-chip emulator
	TCK	Input	Test clock pin for on-chip emulator
	TRACECLK	Output	Outputs the clock for synchronization with the trace data.
	TRACECTL	Output	Outputs the enable signal for trace control.
	TRACEDATA0 to TRACEDATA7	Output	Output the trace data.

**Table 1.4 Pin Functions (2 / 7)**

Classifications	Pin Name	I/O	Description
Bus state controller (BSC)	A25 to A0	Output	Output the address.
	D31 to D0	I/O	Input and output the data.
	CS0# to CS5#	Output	Output the chip select signal for the external memory or device.
	RD#	Output	Outputs the strobe signal which indicates reading is in progress.
	RD/WR#	Output	Outputs the strobe signal which indicates the read or write access.
	BS#	Output	Outputs the status signal which indicates the start of bus cycles.
	AH#	Output	Outputs the address hold signal for the device that uses the multiplexed I/O bus.
	WAIT#	Input	Inputs the external wait control signal which inserts a wait cycle into the bus cycles.
	WE0#	Output	Outputs the write strobe signal to D7 to D0.
	WE1#	Output	Outputs the write strobe signal to D15 to D8.
	WE2#	Output	Outputs the write strobe signal to D23 to D16.
	WE3#	Output	Outputs the write strobe signal to D31 to D24.
	DQMLL	Output	Outputs the data mask enable signal to D7 to D0 when SDRAM is connected.
	DQMLU	Output	Outputs the data mask enable signal to D15 to D8 when SDRAM is connected.
	DQMUL	Output	Outputs the data mask enable signal to D23 to D16 when SDRAM is connected.
	DQMUU	Output	Outputs the data mask enable signal to D31 to D24 when SDRAM is connected.
	RAS#	Output	Outputs the low-address strobe signal to the SDRAM. This pin should be connected to the RAS# pin on the SDRAM.
	CAS#	Output	Outputs the column-address strobe signal to the SDRAM. This pin should be connected to the CAS# pin on the SDRAM.
	CKE	Output	Outputs the clock enable signal to the SDRAM. This pin should be connected to the CKE pin on the SDRAM.
	Direct memory access controller (DMAC)	DREQ0 to DREQ2	Input
DACK0 to DACK2		Output	Output the acknowledge signal which indicates acceptance of the DMA transfer request from the external device.
TEND0 to TEND2		Output	Output the DMA transfer end signal.
Interrupt	NMI	Input	Inputs the non-maskable interrupt request signal.
	IRQ0 to IRQ15	Input	Input the external interrupt request signal.
	ETH0_INT, ETH1_INT, ETH2_INT	Input	Input the Ethernet PHY interrupt request signal.

**Table 1.4 Pin Functions (3 / 7)**

Classifications	Pin Name	I/O	Description
Multi-function timer pulse unit 3 (MTU3a)	MTIOC0A, MTIOC0B, MTIOC0C, MTIOC0D	I/O	TGRA0 to TGRD0 input capture input/output compare output/PWM output pins
	MTIOC1A, MTIOC1B	I/O	TGRA1 and TGRB1 input capture input/output compare output/PWM output pins
	MTIOC2A, MTIOC2B	I/O	TGRA2 and TGRB2 input capture input/output compare output/PWM output pins
	MTIOC3A, MTIOC3B, MTIOC3C, MTIOC3D	I/O	TGRA3 to TGRD3 input capture input/output compare output/PWM output pins
	MTIOC4A, MTIOC4B, MTIOC4C, MTIOC4D	I/O	TGRA4 to TGRD4 input capture input/output compare output/PWM output pins
	MTIC5U, MTIC5V, MTIC5W	Input	TGRU5, TGRV5, and TGRW5 input capture input/dead time compensation input pins
	MTIOC6A, MTIOC6B, MTIOC6C, MTIOC6D	I/O	TGRA6 to TGRD6 input capture input/output compare output/PWM output pins
	MTIOC7A, MTIOC7B, MTIOC7C, MTIOC7D	I/O	TGRA7 to TGRD7 input capture input/output compare output/PWM output pins
Port output enable 3 (POE3)	MTIOC8A, MTIOC8B, MTIOC8C, MTIOC8D	I/O	TGRA8 to TGRD8 input capture input/output compare output
	MTCLKA, MTCLKB, MTCLKC, MTCLKD	Input	External clock input pins for MTU3a
General-purpose PWM timer (GPTa)	POE0#, POE4#, POE8#, POE10#	Input	Input the request signal to place the MTU3a or GPTa in the high impedance state.
	GTIOC0A, GTIOC0B	I/O	GTCCRA0 and GTCCRB0 input capture input/output compare output/PWM output pins
	GTIOC1A, GTIOC1B	I/O	GTCCRA1 and GTCCRB1 input capture input/output compare output/PWM output pins
	GTIOC2A, GTIOC2B	I/O	GTCCRA2 and GTCCRB2 input capture input/output compare output/PWM output pins
	GTIOC3A, GTIOC3B	I/O	GTCCRA3 and GTCCRB3 input capture input/output compare output/PWM output pins
	GTETRQ	Input	External trigger input pin for GPTa

**Table 1.4 Pin Functions (4 / 7)**

Classifications	Pin Name	I/O	Description
16-bit timer pulse unit (TPUa)	TIOCA0, TIOCB0, TIOCC0, TIOCD0	I/O	TGRA0 to TGRD0 input capture input/output compare output/PWM output pins
	TIOCA1, TIOCB1	I/O	TGRA1 and TGRB1 input capture input/output compare output/PWM output pins
	TIOCA2, TIOCB2	I/O	TGRA2 and TGRB2 input capture input/output compare output/PWM output pins
	TIOCA3, TIOCB3, TIOCC3, TIOCD3	I/O	TGRA3 to TGRD3 input capture input/output compare output/PWM output pins
	TIOCA4, TIOCB4	I/O	TGRA4 and TGRB4 input capture input/output compare output/PWM output pins
	TIOCA5, TIOCB5	I/O	TGRA5 and TGRB5 input capture input/output compare output/PWM output pins
	TCLKA, TCLKB, TCLKC, TCLKD	Input	External clock input pins for TPUa (unit 0)
	TIOCA6, TIOCB6, TIOCC6, TIOCD6	I/O	TGRA6 to TGRD6 input capture input/output compare output/PWM output pins
	TIOCA7, TIOCB7	I/O	TGRA7 and TGRB7 input capture input/output compare output/PWM output pins
	TIOCA8, TIOCB8	I/O	TGRA8 and TGRB8 input capture input/output compare output/PWM output pins
	TIOCA9, TIOCB9, TIOCC9, TIOCD9	I/O	TGRA9 to TGRD9 input capture input/output compare output/PWM output pins
	TIOCA10, TIOCB10	I/O	TGRA10 and TGRB10 input capture input/output compare output/PWM output pins
	TIOCA11, TIOCB11	I/O	TGRA11 and TGRB11 input capture input/output compare output/PWM output pins
TCLKE, TCLKF, TCLKG, TCLKH	Input	External clock input pins for TPUa (unit 1)	
Programmable pulse generator (PPG)	PO0 to PO31	Output	Pulse output pins
Compare match timer W (CMTW)	TIC0 to TIC3	Input	CMTW input capture input pins
	TOC0 to TOC3	Output	CMTW output compare output pins
Serial communication interface with FIFO (SCIFA)	SCK0 to SCK4	I/O	Clock I/O pins
	RXD0 to RXD4	Input	Input the receive data.
	TXD0 to TXD4	Output	Output the transmit data.
	CTS0# to CTS4#	I/O	Hardware flow control input (transmission enable signal)/general output
	RTS0# to RTS4#	Output	Hardware flow control output (transmission request signal)/general output
I <sup>2</sup> C bus interface (RIICa)	SCL0, SCL1	I/O	Clock I/O pins. The bus can be directly driven by the N-channel open drain.
	SDA0, SDA1	I/O	Data I/O pins. The bus can be directly driven by the N-channel open drain.



**Table 1.4 Pin Functions (5 / 7)**

Classifications	Pin Name	I/O	Description
Ethernet controller (ETHERC)	ETH0_TXC, ETH1_TXC, ETH2_TXC	Input	Input the 10 M/100 M transmission clock (2.5 MHz/25 MHz).
	ETH0_TXEN, ETH1_TXEN, ETH2_TXEN	Output	Output the transmission enable signal.
	ETH0_TXER, ETH1_TXER, ETH2_TXER	Output	Output the transmission error signal.
	ETH0_TXD0 to 3, ETH1_TXD0 to 3, ETH2_TXD0 to 3	Output	Output the transmission data signal.
	ETH0_RXC, ETH1_RXC, ETH2_RXC	Input	Receive clock input pins
	ETH0_RXDV, ETH1_RXDV, ETH2_RXDV	Input	Input the receive data enable signal.
	ETH0_RXER, ETH1_RXER, ETH2_RXER	Input	Input the receive data error signal.
	ETH0_RXD0 to 3, ETH1_RXD0 to 3, ETH2_RXD0 to 3	Input	Input the receive data signal.
	ETH0_CRS, ETH1_CRS, ETH2_CRS	Input	Input the carrier sense signal.
	ETH0_COL, ETH1_COL, ETH2_COL	Input	Input the collision detection signal.
	ETH_MDC, MII2_MDC	Output	Output the management interface clock.
	ETH_MDIO, MII2_MDIO	I/O	Management data signal I/O pins
	PHYLINK0, PHYLINK1	Input	Input the PHY Link signal.
	ETHSWSECOUT	Output	Event output pin for Ethernet switch per second
	PHYRESETOUT#, PHYRESETOUT2#	Output	Output the PHY RESET signal (PHYRESETOUT#: for Ether0 and Ether1, PHYRESETOUT2#: for Ether2)
EtherCAT slave controller (ECATC) (optional)	CATLEDRUN	Output	Outputs the EtherCAT RUN LED signal.
	CATIRQ	Output	Outputs the EtherCAT IRQ signal.
	CATLEDSTER	Output	Outputs the EtherCAT Dual-color state LED signal.
	CATLEDERR	Output	Outputs the EtherCAT error LED signal.
	CATLINKACT0, CATLINKACT1	Output	Output the EtherCAT link/activity LED signal.
	CATSYNC0, CATSYNC1	Output	Output the EtherCAT SYNC signal.
	CATLATCH0	Input	Input the EtherCAT LATCH signal.
	CATLATCH1	Input	Input the EtherCAT LATCH signal.
	CATI2CLK	Output	Outputs the EtherCAT EEPROM I <sup>2</sup> C clock signal.
	CATI2CDATA	I/O	Inputs/outputs the EtherCAT EEPROM I <sup>2</sup> C data signal.

**Table 1.4 Pin Functions (6 / 7)**

Classifications	Pin Name	I/O	Description
USB 2.0 host/function module	VDD33_USB	Input	Power supply input pin for USB
	VSS_USB	Input	Ground input pin for USB
	DVDD_USB	Input	Digital power supply input pin for USB
	USB_RREF	Input	Reference current input pin for USB. Connect this pin to the VSS_USB pin via 200 $\Omega$ ( $\pm 1\%$ ).
	USB_DP	I/O	USB bus D+ data I/O pin
	USB_DM	I/O	USB bus D- data I/O pin
	USB_VBUSEN	Output	Outputs the VBUS power enable signal for USB.
	USB_OVRCUR	Input	Inputs the overcurrent signal for USB.
	USB_VBUSIN	Input	USB cable connection/disconnection detection input pin
CAN module (RSCAN)	CRXD0, CRXD1	Input	Receive data input pins
	CTXD0, CTXD1	Output	Transmit data output pins
Serial peripheral interface (RSPIa)	RSPCK0 to RSPCK3	I/O	Clock I/O pins
	MOSI0 to MOSI3	I/O	Master transmit data I/O pins
	MISO0 to MISO3	I/O	Slave transmit data I/O pins
	SSL00, SSL10, SSL20, SSL30	I/O	Slave select signal I/O pins
	SSL01, SSL02, SSL03, SSL11	Output	Slave select signal output pins
SPI multi I/O bus controller (SPIBSC)	SPBCLK	Output	Clock output pin
	SPBSSL	Output	Slave select signal output pin
	SPBMO/SPBIO0	I/O	Master transmit data/data 0 I/O pin
	SPBMI/SPBIO1	I/O	Master input data/data 1 I/O pin
	SPBIO2, SPBIO3	I/O	Data 2, data 3 I/O pins
Serial sound interface (SSI)	SSISCK0	I/O	SSI serial bit clock I/O pin
	SSIWS0	I/O	Word select I/O pin
	SSITXD0	Output	Serial data output pin
	SSIRXD0	Input	Serial data input pin
	AUDIO_CLK	Input	Master clock pin for audio
$\Delta\Sigma$ interface (DSMIF)	MCLK0 to MCLK3	I/O	Clock I/O pins
	MDAT0 to MDAT3	Input	Data input pins
12-bit A/D converter (S12ADCa)	AN000 to AN007, AN100 to AN115	Input	Analog input pins for A/D converter
	ADTRG0, ADTRG1	Input	External trigger input pins for the start of A/D conversion
	AN1_ANEX0	Output	Extended analog output pin
	AN1_ANEX1	Input	Extended analog input pin
Analog power supply	AVCC0	Input	Analog power supply input pin for the 12-bit A/D converter (unit 0). Connect this pin to the VCCQ33 pin if the 12-bit A/D converter is not to be used.
	AVSS0	Input	Analog ground input pin for the 12-bit A/D converter (unit 0). Connect this pin to the VSS pin if the 12-bit A/D converter is not to be used.
	VREFH0	Input	Reference power supply input pin for the 12-bit A/D converter (unit 0). Connect this pin to the VCCQ33 pin if the 12-bit A/D converter is not to be used.
	VREFL0	Input	Reference ground pin for the 12-bit A/D converter (unit 0). Connect this pin to the VSS pin if the 12-bit A/D converter is not to be used.

**Table 1.4 Pin Functions (7 / 7)**

Classifications	Pin Name	I/O	Description
Analog power supply	AVCC1	Input	Analog power supply input pin for the 12-bit A/D converter (unit 1). Connect this pin to the VCCQ33 pin if the 12-bit A/D converter is not to be used.
	AVSS1	Input	Analog ground input pin for the 12-bit A/D converter (unit 1). Connect this pin to the VSS pin if the 12-bit A/D converter is not to be used.
	VREFH1	Input	Reference power supply input pin for the 12-bit A/D converter (unit 1). Connect this pin to the VCCQ33 pin if the 12-bit A/D converter is not to be used.
	VREFL1	Input	Reference ground pin for the 12-bit A/D converter (unit 1). Connect this pin to the VSS pin if the 12-bit A/D converter is not to be used.
I/O ports	P00 to P07	I/O	8-bit I/O pin
	P10 to P17	I/O	8-bit I/O pin
	P20 to P27	I/O	8-bit I/O pins
	P30 to P37	Input, I/O	1-bit input pin (P30), 7-bit I/O pins (P31 to P37) I/O pins
	P40 to P47	I/O	8-bit I/O pins
	P50 to P56	I/O	7-bit I/O pins
	P60 to P67	I/O	8-bit I/O pins
	P70 to P77	I/O	8-bit I/O pins
	P80 to P87	I/O	8-bit I/O pins
	P90 to P97	I/O	8-bit I/O pins
	PA0 to PA7	I/O	8-bit I/O pins
	PB0 to PB7	I/O	8-bit I/O pins
	PC0 to PC7	Input	8-bit input pins
	PD0 to PD7	I/O	8-bit I/O pins
	PE0 to PE7	I/O	8-bit I/O pins
	PF5 to PF7	I/O	3-bit I/O pins
	PG0 to PG7	I/O	8-bit I/O pins
	PH0 to PH7	I/O	8-bit I/O pins
	PJ0 to PJ7	I/O	8-bit I/O pins
	PK0 to PK7	I/O	8-bit I/O pins
	PL0 to PL7	I/O	8-bit I/O pins
	PM0 to PM7	I/O	8-bit I/O pins
	PN0 to PN7	I/O	8-bit I/O pins
	PP0 to PP7	I/O	8-bit I/O pins
	PR0 to PR7	I/O	8-bit I/O pins
	PS0 to PS7	I/O	8-bit I/O pins
	PT0 to PT7	I/O	8-bit I/O pins
PU0 to PU7	I/O	8-bit I/O pins	
Encoder I/F*1	ENCIF00 to ENCIF12	I/O	I/O pins for multi-protocol encoder interface

Note 1. Only in products with the encoder interfaces.

### 1.5 Pin Assignments

Figure 1.2 and Figure 1.3 show the pin arrangement. Table 1.5 and Table 1.6 show the pin assignments. Table 1.7 and Table 1.8 show the lists of pin functions.

	1	2	3	4	5	6	7	8	9	10	11	12	13	14	15	16	17	18	19	20
A	VSS	PC2	PJ3	PJ1	PF7	PB4	PB0	PC0	PF6	VCC Q33	P54	VSS	AN0 07	AN0 05	AN0 02	AVC C0	AVC C1	VRE FH1	P17	VSS
B	PJ5	PJ4	PC3	PJ2	PJ0	PB5	PB2	PC1	PB7	P86	PD7	P52	AN0 06	AN0 03	AN0 01	AVS S0	AVS S1	VRE FL1	P16	P15
C	PJ7	PJ6	PU2	PL7	PL5	PB6	PB3	PB1	PF5	P87	PD6	P53	P51	AN0 04	AN0 00	VRE FL0	VRE FH0	PD2	P14	P13
D	P81	P80	PU3															PD0	P96	P95
E	P84	P82	PU1	PU0	PL6	PL4	PL2	PL0	PK7	PK6	PD5	P56	PD4	VCC Q33	PD1					
F	PC4	P83	P85	PU4	VSS	VCC Q33	PL3	PL1	PK5	PK4	P55	P50	PD3	PK2	P90					
G	PU6	PC5	VCC Q33	PU5	PM0									PK3	PA7	PA4	PA3	P11		
H	PU7	PM1	P35	ERR ORO UT#	VCC Q33	VDD	VDD	VDD	VDD	VDD	VSS					PA6	PA5	PA2	PK0	PK1
J	PM6	PM3	PM2	P33	TRS T#	VDD	VSS	VSS	VSS	VSS	VDD					VCC Q33	PA1	PA0	PT7	PT6
K	PM7	PM5	PM4	P34	PLL VDD 1	VDD	VSS	VSS	VSS	VSS	VDD					VSS	P77	P76	P75	PT5
L	MD1	MD2	TMS	TCK	PLL VSS 1	VDD	VSS	VSS	VSS	VSS	VDD					VSS	PE7	P72	P73	P74
M	XTAL	EXTAL	OSCTH	BSCANP	PLL VDD 0	VDD	VSS	VSS	VSS	VSS	VDD					VCC Q33	PE6	P70	PT4	P71
N	VSS	MD0	RST OUT #	RES #	PLL VSS 0	VDD	VSS	VDD	VDD	VDD	VDD					PE2	PE4	PE5	PT2	PT3
P	VSS USB	VDD 33 USB	USB _RR EF	P31	VCC Q33									P06	P07	PE3	PT0	PT1		
R	USB _DP	USB _DM	P30	PN0	PN2	PG0	PG2	PG7	PH2	PH4	PH6	P23	P27	P47	VCC Q33	VCC Q33	PS6	PS7		
T	DVD D_USB	VDD 33 USB	P32	PC6	P37	P36	PG3	PG6	PH3	VCC Q33	PH5	VCC Q33	P26	VCC Q33	VSS	VSS	PE0	PE1		
U	P60	P63	PN1															P00	P04	P03
V	P61	P64	PN3	PN4	PC7	PG1	PG4	PG5	PH0	PH1	PH7	P20	P21	VSS	P45	P46	PS2	P05	P01	P02
W	P62	P65	PN5	PN6	PP0	PP2	PP4	PP6	PP7	PR1	PR3	PR5	P24	P22	P44	P43	PS1	PS3	PS4	PS5
Y	VSS	P67	P66	PN7	PP1	PP3	PP5	VSS	PR0	PR2	PR4	PR6	PR7	P25	P41	P42	P40	PS0	P10	VSS
	1	2	3	4	5	6	7	8	9	10	11	12	13	14	15	16	17	18	19	20

Figure 1.2 Pin Arrangement (320-Pin FBGA) (Top View)

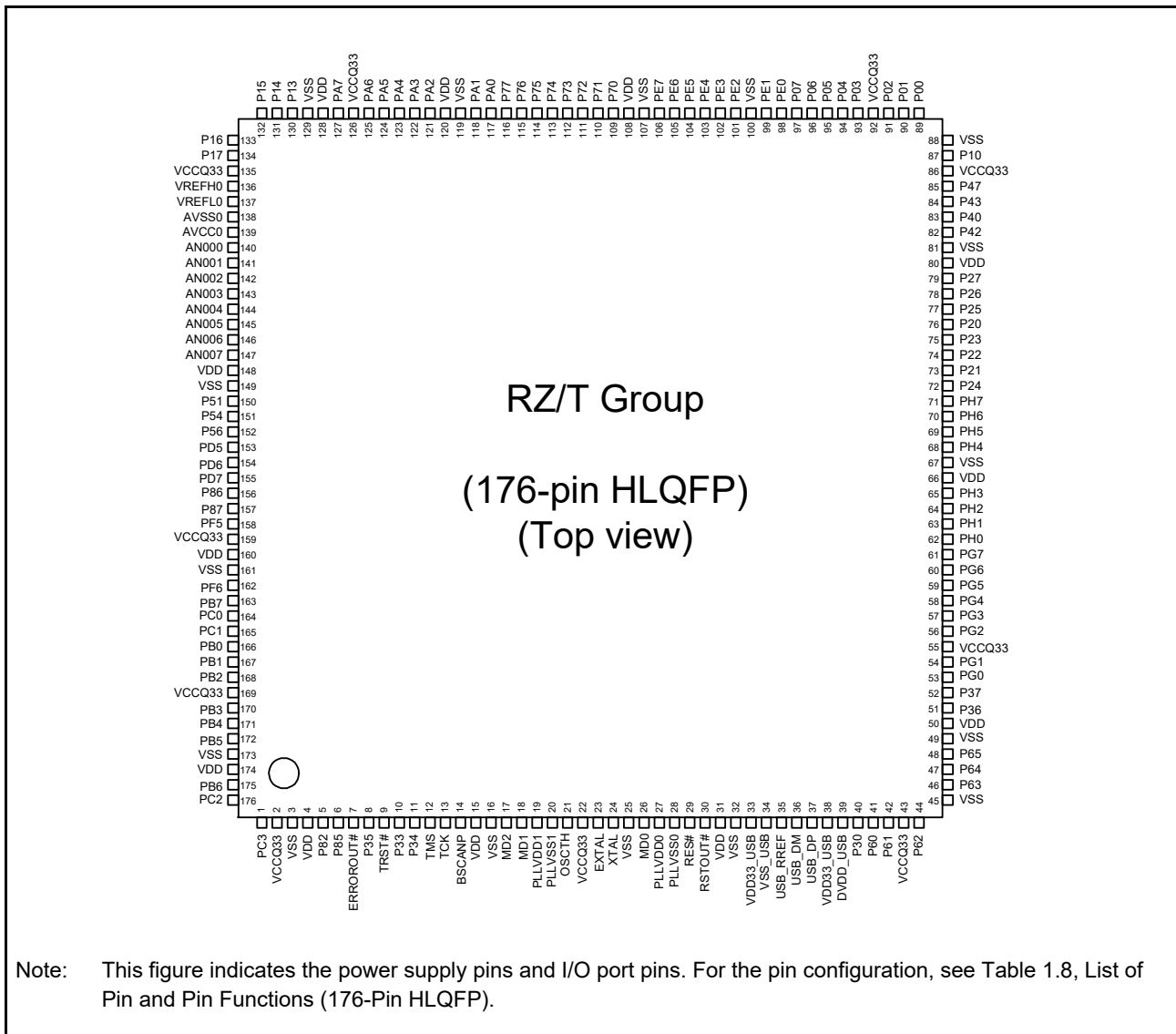

Figure 1.3 Pin Arrangement (176-pin HLQFP)

**Table 1.5 Pin Assignments (320-Pin FBGA) (1 / 8)**

Pin Number	Pin Name
A1	VSS
A2	PC2 / ETH0_TXC / ETH1_RXD2 / CATI2CDATA / SDA0
A3	PJ3 / IRQ11 / ETH0_TXD0 / ADTRG0
A4	PJ1 / ETH0_TXD2 / CATLEDSTER / RSPCK3
A5	PF7 / IRQ7 / A25 / ETH0_TXER / RTS3# / SSL30
A6	PB4 / A24 / ETH1_COL / ETH0_RXER / CATSYNC0 / CATLATCH0 / RXD3 / MOSI3 / MDAT0
A7	PB0 / ETH1_RXDV / MTCLKB / TCLKD / TIC3
A8	PC0 / WAIT# / ETH1_RXD2 / GTETRG / SCL1 / MDAT3
A9	PF6 / ETH1_RXD0 / MTIOC3D / GTIOC0B / TOC2
A10	VCCQ33
A11	P54 / CLKOUT25M1 / MOSI2
A12	VSS
A13	AN007
A14	AN005
A15	AN002
A16	AVCC0
A17	AVCC1
A18	VREFH1
A19	P17 / CS5# / ETH1_TXER / PHYRESETOUT# / ADTRG0
A20	VSS
B1	PJ5 / ETH0_RXD1 / TIOCD0 / RXD3
B2	PJ4 / ETH0_RXD0 / TXD3
B3	PC3 / ETH0_RXC / ETH0_RXDV / CATI2CCLK / RXD4 / SCL0 / CRXD1
B4	PJ2 / IRQ10 / ETH0_TXD1 / MISO3
B5	PJ0 / IRQ8 / ETH0_TXD3 / CATLEDERR / MOSI3
B6	PB5 / ETH_MDIO / TCLKB / POE0# / POE10# / CTS3# / RSPCK3
B7	PB2 / ETH1_RXC / ETH0_RXD1 / CATSYNC1 / CATLATCH1 / MTIOC1A / SSL30 / MDAT1
B8	PC1 / IRQ9 / ETH1_RXD3 / PHYLINK0 / SDA1 / MDAT2
B9	PB7 / ETH1_RXD1 / MTIOC3B / GTIOC0A / TOC3
B10	P86 / AN1_ANEX0 / ETH1_TXD0 / MTIOC4B / GTIOC2A / TOC1 / RSPCK2
B11	PD7 / AN115 / ETH1_TXD1 / MTIOC4D / GTIOC2B / TOC0
B12	P52 / ETH0_INT / SSL20
B13	AN006
B14	AN003
B15	AN001
B16	AVSS0
B17	AVSS1
B18	VREFL1
B19	P16 / CS4# / CS2# / MTIOC3B / GTIOC0A / ENCIF12
B20	P15 / CS3# / CKE / MTIOC3D / GTIOC0B / ENCIF11
C1	PJ7 / IRQ15 / ETH0_RXD3 / CATLEDRUN / CTS3#
C2	PJ6 / IRQ14 / ETH0_RXD2 / CATIRQ / SCK3
C3	PU2 / IRQ2 / ETH2_CRS / TIOCD9 / RXD3
C4	PL7 / IRQ15 / ETH2_RXDV

**Table 1.5 Pin Assignments (320-Pin FBGA) (2 / 8)**

Pin Number	Pin Name
C5	PL5 / ETH2_RXD2 / TIOCA8
C6	PB6 / ETH_MDC / TCLKA / SCK3 / RTS4# / MISO3
C7	PB3 / IRQ3 / CS1# / ETH1_CRS / PHYRESETOUT# / TXD3 / CTXD1 / MCLK0
C8	PB1 / ETH1_RXER / MTCLKA / TCLKC / CTS4#
C9	PF5 / ETH1_TXEN / MTIOC4A / GTIOC1A / TIC2
C10	P87 / AN1_ANEX1 / A23 / ETH1_TXC / ETH0_RXD0 / MTIOC4C / GTIOC1B / MCLK1
C11	PD6 / AN114 / A22 / ETH1_TXD2 / ETH0_TXD1 / TIC1 / MISO2 / MCLK2
C12	P53 / ETH1_INT / MISO2
C13	P51 / IRQ1 / PHYLINK1 / RSPCK2
C14	AN004
C15	AN000
C16	VREFLO
C17	VREFH0
C18	PD2 / AN110 / WAIT#
C19	P14 / CAS# / MTIOC4A / GTIOC1A / ENCIF10
C20	P13 / RAS# / MTIOC4C / GTIOC1B
D1	P81 / ETH0_RXER / TIOCC0 / CTS4#
D2	P80 / IRQ8 / ETH0_RXDV / TIOCC3 / RTS4#
D3	PU3 / ETH2_COL / TIOCD6 / TXD3
D18	PD0 / AN108 / CS4#
D19	P96 / AN106 / POE0# / POE10# / ENCIF09
D20	P95 / AN105 / IRQ13 / MTCLKA / CTS2#
E1	P84 / ETH0_COL / CATLINKACT1 / RXD4
E2	P82 / ETH0_TXEN / ETH1_CRS / TIOCD3 / SCK4 / RTS3# / USB_OVRCUR
E3	PU1 / ETH2_RXC / TIOCA11 / SCK3
E5	PU0 / ETH2_RXER / TIOCA10
E6	PL6 / ETH2_RXD3 / TIOCA9
E7	PL4 / IRQ4 / ETH2_RXD1
E8	PL2 / ETH2_TXEN / TIOCA6 / ADTRG1
E9	PL0 / ETH2_TXD0 / TIOCB9
E10	PK7 / ETH2_TXD2 / TIOCB7
E11	PK6 / ETH2_TXD3 / TIOCB6
E12	PD5 / AN113 / A21 / ETH1_TXD3 / ETH0_TXD0 / TIC0 / SSL20 / MCLK3
E13	P56 / BS# / ETH1_TXER
E14	PD4 / AN112 / ETH2_INT
E15	VCCQ33
E16	PD1 / AN109 / CS1#
E18	P97 / AN107 / IRQ7 / A25 / ADTRG1
E19	P94 / AN104 / IRQ4 / MTCLKB / RTS2# / ENCIF08
E20	P93 / AN103 / MTIOC1A / TIC3 / SCK2 / ENCIF07
F1	PC4 / CATI2CCLK / TCLKH / SCL0
F2	P83 / IRQ11 / ETH0_CRS / CATLINKACT0 / TXD4
F3	P85 / IRQ5 / CLKOUT25M0 / TXD4 / SCK4 / USB_VBUSEN
F5	PU4 / MII2_MDC / TIOCC9 / CTS3#
F6	VSS

**Table 1.5 Pin Assignments (320-Pin FBGA) (3 / 8)**

Pin Number	Pin Name
F7	VCCQ33
F8	PL3 / ETH2_RXD0 / TIOCA7
F9	PL1 / ETH2_TXC / TIOCB10
F10	PK5 / ETH2_TXD1 / TIOCB8
F11	PK4 / ETH2_TXER / TIOCB11 / MOSI2
F12	P55 / IRQ5 / A24 / ETHSWSECOUT
F13	P50 / IRQ8 / CS1# / PHYLINK0
F14	PD3 / AN111 / PHYRESETOUT2#
F15	PK2 / A23
F16	P90 / AN100 / RAS# / TIOCA5 / TXD4
F18	P92 / AN102 / CS5# / TOC3 / RXD2
F19	P91 / AN101 / CAS# / TXD2 / ENCIF06
F20	P12 / MTIOC4B / GTIOC2A
G1	PU6 / PHYRESETOUT# / TCLKF / CTS4#
G2	PC5 / CATI2CDATA / TCLKG / SDA0
G3	VCCQ33
G5	PU5 / IRQ13 / MII2_MDIO / TIOCC6 / RTS3#
G6	PM0 / CLKOUT25M2 / TXD4
G15	PK3 / A24
G16	PA7 / IRQ7 / D31 / A22 / MTIOC6B / GTIOC3B / RTS2# / MCLK0
G18	PA4 / D28 / ETH1_INT / TIOCA3 / ADTRG0 / RXD2 / TEND2 / MDAT1
G19	PA3 / D27 / ETHSWSECOUT / GTETRG / TIOCA2 / SCK2 / DACK2 / MCLK2
G20	P11 / IRQ9 / MTIOC4D / GTIOC2B
H1	PU7 / CATIRQ / RXD4
H2	PM1 / CATLEDERR / SCK4
H3	P35 / NMI
H5	ERROROUT#
H6	VCCQ33
H8	VDD
H9	VDD
H10	VDD
H11	VDD
H12	VDD
H13	VSS
H15	PA6 / IRQ6 / D30 / A21 / GTIOC3A / CTS2# / MDAT0
H16	PA5 / D29 / ETH0_INT / ETH1_TXER / TIOCA4 / TXD2 / MCLK1
H18	PA2 / D26 / MTIOC3B / GTIOC0A / SSL02 / DREQ2 / MDAT2 / ENCIF05
H19	PK0 / CAS# / PO31 / ENCIF11
H20	PK1 / CS5# / ENCIF12
J1	PM6 / IRQ6 / CATLINKACT0 / PO19
J2	PM3 / CATSYNC0 / CATLATCH0 / PO16
J3	PM2 / CATSYNC1 / CATLATCH1 / TCLKE / RTS4#
J5	P33 / TDO
J6	TRST#
J8	VDD



**Table 1.5 Pin Assignments (320-Pin FBGA) (4 / 8)**

Pin Number	Pin Name
J9	VSS
J10	VSS
J11	VSS
J12	VSS
J13	VDD
J15	VCCQ33
J16	PA1 / D25 / MTIOC3D / GTIOC0B / MISO0 / AUDIO_CLK / TRACEDATA7 / MCLK3
J18	PA0 / D24 / MTIOC4A / GTIOC1A / MOSI0 / TRACEDATA6 / MDAT3
J19	PT7 / A22 / DACK2 / ENCIF10
J20	PT6 / A21 / DREQ2
K1	PM7 / CATLINKACT1 / PO20
K2	PM5 / CATLEDSTER / PO18
K3	PM4 / CATLEDRUN / PO17
K5	P34 / TDI
K6	PLLVDD1
K8	VDD
K9	VSS
K10	VSS
K11	VSS
K12	VSS
K13	VDD
K15	VSS
K16	P77 / D23 / MTIOC4C / GTIOC1B / RSPCK0 / TRACEDATA5
K18	P76 / D22 / MTIOC4B / GTIOC2A / SSL01 / SSIWS0 / TRACEDATA4
K19	P75 / IRQ13 / D21 / MTIOC4D / GTIOC2B / SSL00 / TRACEDATA3/ ENCIF04
K20	PT5 / BS# / PO30 / TEND2
L1	MD1
L2	MD2
L3	TMS
L5	TCK
L6	PLLVSS1
L8	VDD
L9	VSS
L10	VSS
L11	VSS
L12	VSS
L13	VDD
L15	VSS
L16	PE7 / D15 / MTIOC7A / TIOCD3 / POE8# / SCK1 / RSPCK0 / TRACEDATA7
L18	P72 / D18 / MTIOC1A / TIC2 / TXD1 / SSITXD0 / TRACEDATA0 / ENCIF02
L19	P73 / IRQ3 / D19 / MTCLKB / RXD1 / SSIRXD0 / TRACEDATA1 / ENCIF03
L20	P74 / D20 / MTCLKA / CTS1# / SSL03 / SSISCK0 / TRACEDATA2
M1	XTAL
M2	EXTAL
M3	OSCTH

**Table 1.5 Pin Assignments (320-Pin FBGA) (5 / 8)**

Pin Number	Pin Name
M5	BSCANP
M6	PLLVDD0
M8	VDD
M9	VSS
M10	VSS
M11	VSS
M12	VSS
M13	VDD
M15	VCCQ33
M16	PE6 / IRQ6 / D14 / MTIOC0A / TIOC0D / RXD1 / MISO0 / TRACEDATA6
M18	P70 / IRQ0 / D16 / MTIOC6D / RTS1# / USB_OVRCUR / TRACECLK / ENCIF00
M19	PT4 / CS3# / PO29
M20	P71 / D17 / POE0# / POE10# / TOC2 / SCK1 / TRACECTL / ENCIF01
N1	VSS
N2	MD0
N3	RSTOUT#
N5	RES#
N6	PLLVSS0
N8	VDD
N9	VSS
N10	VDD
N11	VDD
N12	VDD
N13	VDD
N15	PE2 / IRQ2 / D10 / MTCLKC / TIOCB4 / SSL02 / TRACEDATA2
N16	PE4 / D12 / MTIOC0B / TIOCC0 / RTS1# / SSL00 / TRACEDATA4
N18	PE5 / D13 / MTIOC0C / TIOCC3 / TXD1 / MOSI0 / TRACEDATA5
N19	PT2 / TIOCA1 / TIOCB1 / PO27
N20	PT3 / IRQ11 / TIOCA0 / TIOCB0 / PO28 / CTS2# / ENCIF09
P1	VSS_USB
P2	VDD33_USB
P3	USB_RREF
P5	P31 / USB_VBUSEN
P6	VCCQ33
P15	P06 / D6 / MTIOC2B / TIOCB0
P16	P07 / D7 / MTIOC2A / TIOCB1
P18	PE3 / IRQ3 / D11 / MTIOC0D / TIOCB5 / CTS1# / SSL01 / TRACEDATA3
P19	PT0 / IRQ0 / TIOCA3 / TIOCB3 / PO25 / SCK2 / ENCIF07
P20	PT1 / TIOCA2 / TIOCB2 / PO26 / RTS2# / ENCIF08
R1	USB_DP
R2	USB_DM
R3	P30 / CRXD0 / USB_VBUSIN
R5	PN0 / MTIOC8D / SSL10
R6	PN2 / IRQ10 / MTIOC8B / MOSI1
R7	PG0 / A1 / PO2

**Table 1.5 Pin Assignments (320-Pin FBGA) (6 / 8)**

Pin Number	Pin Name
R8	PG2 / A3 / PO4 / TOC0 / RSPCK1
R9	PG7 / A8 / PO9
R10	PH2 / A11 / MTIOC2A / PO12
R11	PH4 / IRQ4 / A13 / PO14
R12	PH6 / A15 / MTIOC7D / RTS0#
R13	P23 / A0 / MTIC5U / TXD0 / DACK1
R14	P27 / A20 / MTIOC8C / TIOCB0 / RTS0#
R15	P47 / WE3#/DQMUU/AH# / MTIOC6C
R16	VCCQ33
R18	VCCQ33
R19	PS6 / IRQ14 / TIOCA5 / TIOCB5 / PO23 / RXD2 / ENCIF06
R20	PS7 / TIOCA4 / TIOCB4 / PO24 / TXD2
T1	DVDD_USB
T2	VDD33_USB
T3	P32 / IRQ10 / USB_OVRCUR
T5	PC6 / TCLKC / SCL1 / CRXD0 / DREQ0 / USB_VBUSIN
T6	P37 / WE1#/DQMLU / PO1
T7	P36 / WE0#/DQMLL / PO0
T8	PG3 / A4 / PO5 / TIC1 / MISO1
T9	PG6 / A7 / TCLKB / PO8 / SSL11
T10	PH3 / A12 / MTIOC1B / PO13
T11	VCCQ33
T12	PH5 / A14 / PO15
T13	VCCQ33
T14	P26 / A19 / MTIOC8D / DREQ1
T15	VCCQ33
T16	VSS
T18	VSS
T19	PE0 / D8 / MTIOC1B / TIOCB2 / TRACEDATA0
T20	PE1 / D9 / MTCLKD / TIOCB3 / SSL03 / TRACEDATA1
U1	P60 / SPBSSL / CTXD0 / TEND0
U2	P63 / SPBMO/SPBIO0
U3	PN1 / MTIOC8C / PO21 / MISO1 / ENCIF09
U18	P00 / D0 / MTIOC6A / TIOCA1 / ADTRG1 / TRACECTL
U19	P04 / D4 / MTIOC3C / TIOCA5
U20	P03 / D3 / MTIC5U / TIOCA4
V1	P61 / SPBIO3 / CTXD1 / DACK0
V2	P64 / SPBBI/SPBIO1
V3	PN3 / MTIOC8A / RSPCK1
V4	PN4 / IRQ12 / MTIOC6C / TIOCC6 / SSL11
V5	PC7 / TIC0 / SDA1 / CRXD1
V6	PG1 / A2 / PO3
V7	PG4 / A5 / PO6 / TOC1 / MOSI1
V8	PG5 / A6 / TCLKA / PO7 / SSL10
V9	PH0 / A9 / PO10

**Table 1.5 Pin Assignments (320-Pin FBGA) (7 / 8)**

Pin Number	Pin Name
V10	PH1 / A10 / MTIOC2B / PO11
V11	PH7 / A16 / MTIC5W
V12	P20 / A17 / MTCLKD
V13	P21 / IRQ1 / CS0# / MTIC5V / TIOCB1 / CTS0#
V14	VSS
V15	P45 / CS2#
V16	P46 / CKE
V17	PS2 / MTIOC7C / SSIWS0
V18	P05 / D5 / MTIOC3A
V19	P01 / D1 / MTIC5W / TIOCA2
V20	P02 / D2 / MTIC5V / TIOCA3
W1	P62 / SPBCLK
W2	P65 / SPBIO2 / DREQ0
W3	PN5 / IRQ5 / MTIOC6A / TIOCD9 / ENCIF10
W4	PN6 / MTIOC3C / TIOCC9 / MCLK3 / ENCIF11
W5	PP0 / POE8# / TEND0 / MCLK2
W6	PP2 / MTIOC0C / TCLKH / MCLK1
W7	PP4 / MTIOC0A / MCLK0
W8	PP6 / TIOCA11 / RXD1 / TRACECTL / ENCIF06
W9	PP7 / TCLKF / TCLKH / SCK1 / DACK1 / TRACECLK
W10	PR1 / IRQ9 / POE4# / CTS1# / TEND1 / TRACEDATA1 / ENCIF08
W11	PR3 / TIOCA10 / TIOCB10 / TRACEDATA3 / ENCIF01
W12	PR5 / TIOCA8 / TIOCB8 / TRACEDATA5 / ENCIF03
W13	P24 / IRQ12 / RD/WR# / RXD0
W14	P22 / IRQ2 / RD# / MTIOC7B / TIOCD0 / SCK0
W15	P44 / IRQ12 / WAIT# / TCLKD / ADTRG0 / CTS0#
W16	P43 / WE2#/DQMUL / MTIOC8B / USB_VBUSEN
W17	PS1 / IRQ1 / MTIOC7B / SSISCK0
W18	PS3 / MTIOC7A / SSIRXD0
W19	PS4 / MTIOC6D / SSITXD0
W20	PS5 / MTIOC6B
Y1	VSS
Y2	P67 / IRQ15 / GTIOC3B / CTXD0 / TEND0 / USB_OVRCUR
Y3	P66 / IRQ14 / GTIOC3A / CTXD1 / DACK0 / USB_VBUSEN
Y4	PN7 / MTIOC3A / TIOCD6 / DREQ0 / MDAT3 / ENCIF12
Y5	PP1 / MTIOC0D / DACK0 / MDAT2
Y6	PP3 / MTIOC0B / TCLKC / MDAT1
Y7	PP5 / PO22 / MDAT0
Y8	VSS
Y9	PR0 / TCLKE / TCLKG / TXD1 / DREQ1 / TRACEDATA0 / ENCIF07
Y10	PR2 / TIOCA11 / TIOCB11 / RTS1# / TRACEDATA2 / ENCIF00
Y11	PR4 / TIOCA9 / TIOCB9 / TRACEDATA4 / ENCIF02
Y12	PR6 / TIOCA7 / TIOCB7 / TRACEDATA6 / ENCIF04
Y13	PR7 / TIOCA6 / TIOCB6 / TRACEDATA7 / ENCIF05
Y14	P25 / A18 / MTCLKC / TEND1

**Table 1.5 Pin Assignments (320-Pin FBGA) (8 / 8)**

Pin Number	Pin Name
Y15	P41 / BS# / SCK0
Y16	P42 / MTIOC7C / RXD0
Y17	P40 / MTIOC8A / TXD0
Y18	PS0 / MTIOC7D / AUDIO_CLK
Y19	P10 / IRQ0 / CKIO / TIOCA0 / TRACECLK
Y20	VSS

**Table 1.6 Pin Assignments (176-Pin HLQFP) (1 / 4)**

Pin Number	Pin Name
1	PC3 / ETH0_RXC / ETH0_RXDV / RXD4 / SCL0 / CRXD1
2	VCCQ33
3	VSS
4	VDD
5	P82 / ETH0_TXEN / ETH1_CRS / TIOCD3 / SCK4 / RTS3# / USB_OVRCUR
6	P85 / IRQ5 / CLKOUT25M0 / TXD4 / SCK4 / USB_VBUSEN
7	ERROROUT#
8	P35 / NMI
9	TRST#
10	P33 / TDO
11	P34 / TDI
12	TMS
13	TCK
14	BSCANP
15	VDD
16	VSS
17	MD2
18	MD1
19	PLLVDD1
20	PLLVSS1
21	OSCTH
22	VCCQ33
23	EXTAL
24	XTAL
25	VSS
26	MD0
27	PLLVDD0
28	PLLVSS0
29	RES#
30	RSTOUT#
31	VDD
32	VSS
33	VDD33_USB
34	VSS_USB
35	USB_RREF
36	USB_DM
37	USB_DP
38	VDD33_USB
39	DVDD_USB
40	P30 / CRXD0 / USB_VBUSIN
41	P60 / SPBSSL / CTXD0 / TEND0
42	P61 / SPBIO3 / CTXD1 / DACK0
43	VCCQ33
44	P62 / SPBCLK

**Table 1.6 Pin Assignments (176-Pin HLQFP) (2 / 4)**

Pin Number	Pin Name
45	VSS
46	P63 / SPBMO/SPBIO0
47	P64 / SPBMI/SPBIO1
48	P65 / SPBIO2 / DREQ0
49	VSS
50	VDD
51	P36 / WE0#/DQMLL / PO0
52	P37 / WE1#/DQMLU / PO1
53	PG0 / A1 / PO2
54	PG1 / A2 / PO3
55	VCCQ33
56	PG2 / A3 / PO4 / TOC0 / RSPCK1
57	PG3 / A4 / PO5 / TIC1 / MISO1
58	PG4 / A5 / PO6 / TOC1 / MOSI1
59	PG5 / A6 / TCLKA / PO7 / SSL10
60	PG6 / A7 / TCLKB / PO8 / SSL11
61	PG7 / A8 / PO9
62	PH0 / A9 / PO10
63	PH1 / A10 / MTIOC2B / PO11
64	PH2 / A11 / MTIOC2A / PO12
65	PH3 / A12 / MTIOC1B / PO13
66	VDD
67	VSS
68	PH4 / IRQ4 / A13 / PO14
69	PH5 / A14 / PO15
70	PH6 / A15 / MTIOC7D / RTS0#
71	PH7 / A16 / MTIC5W
72	P24 / IRQ12 / RD/WR# / RXD0
73	P21 / IRQ1 / CS0# / MTIC5V / TIOCB1 / CTS0#
74	P22 / IRQ2 / RD# / MTIOC7B / TIOCD0 / SCK0
75	P23 / A0 / MTIC5U / TXD0 / DACK1
76	P20 / A17 / MTCLKD
77	P25 / A18 / MTCLKC / TEND1
78	P26 / A19 / MTIOC8D / DREQ1
79	P27 / A20 / MTIOC8C / TIOCB0 / RTS0#
80	VDD
81	VSS
82	P42 / MTIOC7C / RXD0
83	P40 / MTIOC8A / TXD0
84	P43 / WE2#/DQMUL / MTIOC8B / USB_VBUSEN
85	P47 / WE3#/DQMUU/AH# / MTIOC6C
86	VCCQ33
87	P10 / IRQ0 / CKIO / TIOCA0 / TRACECLK
88	VSS
89	P00 / D0 / MTIOC6A / TIOCA1 / TRACECTL

**Table 1.6 Pin Assignments (176-Pin HLQFP) (3 / 4)**

Pin Number	Pin Name
90	P01 / D1 / MTIC5W / TIOCA2
91	P02 / D2 / MTIC5V / TIOCA3
92	VCCQ33
93	P03 / D3 / MTIC5U / TIOCA4
94	P04 / D4 / MTIOC3C / TIOCA5
95	P05 / D5 / MTIOC3A
96	P06 / D6 / MTIOC2B / TIOCB0
97	P07 / D7 / MTIOC2A / TIOCB1
98	PE0 / D8 / MTIOC1B / TIOCB2 / TRACEDATA0
99	PE1 / D9 / MTCLKD / TIOCB3 / SSL03 / TRACEDATA1
100	VSS
101	PE2 / IRQ2 / D10 / MTCLKC / TIOCB4 / SSL02 / TRACEDATA2
102	PE3 / IRQ3 / D11 / MTIOC0D / TIOCB5 / CTS1# / SSL01 / TRACEDATA3
103	PE4 / D12 / MTIOC0B / TIOCC0 / RTS1# / SSL00 / TRACEDATA4
104	PE5 / D13 / MTIOC0C / TIOCC3 / TXD1 / MOSI0 / TRACEDATA5
105	PE6 / IRQ6 / D14 / MTIOC0A / TIOCD0 / RXD1 / MISO0 / TRACEDATA6
106	PE7 / D15 / MTIOC7A / TIOCD3 / POE8# / SCK1 / RSPCK0 / TRACEDATA7
107	VSS
108	VDD
109	P70 / IRQ0 / D16 / MTIOC6D / RTS1# / USB_OVRCUR / TRACECLK
110	P71 / D17 / POE0# / POE10# / TOC2 / SCK1 / TRACECTL
111	P72 / D18 / MTIOC1A / TIC2 / TXD1 / SSITXD0 / TRACEDATA0
112	P73 / IRQ3 / D19 / MTCLKB / RXD1 / SSIRXD0 / TRACEDATA1
113	P74 / D20 / MTCLKA / CTS1# / SSL03 / SSISCK0 / TRACEDATA2
114	P75 / IRQ13 / D21 / MTIOC4D / GTIOC2B / SSL00 / TRACEDATA3
115	P76 / D22 / MTIOC4B / GTIOC2A / SSL01 / SSIWS0 / TRACEDATA4
116	P77 / D23 / MTIOC4C / GTIOC1B / RSPCK0 / TRACEDATA5
117	PA0 / D24 / MTIOC4A / GTIOC1A / MOSI0 / TRACEDATA6 / MDAT3
118	PA1 / D25 / MTIOC3D / GTIOC0B / MISO0 / AUDIO_CLK / TRACEDATA7 / MCLK3
119	VSS
120	VDD
121	PA2 / D26 / MTIOC3B / GTIOC0A / SSL02 / DREQ2 / MDAT2
122	PA3 / D27 / ETHSWSECOUT / GTETRQ / TIOCA2 / SCK2 / DACK2 / MCLK2
123	PA4 / D28 / ETH1_INT / TIOCA3 / ADTRG0 / RXD2 / TEND2 / MDAT1
124	PA5 / D29 / ETH0_INT / ETH1_TXER / TIOCA4 / TXD2 / MCLK1
125	PA6 / IRQ6 / D30 / A21 / GTIOC3A / CTS2# / MDAT0
126	VCCQ33
127	PA7 / IRQ7 / D31 / A22 / MTIOC6B / GTIOC3B / RTS2# / MCLK0
128	VDD
129	VSS
130	P13 / RAS# / MTIOC4C / GTIOC1B
131	P14 / CAS# / MTIOC4A / GTIOC1A
132	P15 / CS3# / CKE / MTIOC3D / GTIOC0B
133	P16 / CS4# / CS2# / MTIOC3B / GTIOC0A
134	P17 / CS5# / ETH1_TXER / PHYRESETOUT# / ADTRG0



**Table 1.6 Pin Assignments (176-Pin HLQFP) (4 / 4)**

Pin Number	Pin Name
135	VCCQ33
136	VREFH0
137	VREFL0
138	AVSS0
139	AVCC0
140	AN000
141	AN001
142	AN002
143	AN003
144	AN004
145	AN005
146	AN006
147	AN007
148	VDD
149	VSS
150	P51 / IRQ1 / PHYLINK1 / RSPCK2
151	P54 / CLKOUT25M1 / MOSI2
152	P56 / BS# / ETH1_TXER
153	PD5 / A21 / ETH1_TXD3 / ETH0_TXD0 / TIC0 / SSL20 / MCLK3
154	PD6 / A22 / ETH1_TXD2 / ETH0_TXD1 / TIC1 / MISO2 / MCLK2
155	PD7 / ETH1_TXD1 / MTIOC4D / GTIOC2B / TOC0
156	P86 / ETH1_TXD0 / MTIOC4B / GTIOC2A / TOC1 / RSPCK2
157	P87 / A23 / ETH1_TXC / ETH0_RXD0 / MTIOC4C / GTIOC1B / MCLK1
158	PF5 / ETH1_TXEN / MTIOC4A / GTIOC1A / TIC2
159	VCCQ33
160	VDD
161	VSS
162	PF6 / ETH1_RXD0 / MTIOC3D / GTIOC0B / TOC2
163	PB7 / ETH1_RXD1 / MTIOC3B / GTIOC0A / TOC3
164	PC0 / WAIT# / ETH1_RXD2 / GTETRQ / SCL1 / MDAT3
165	PC1 / IRQ9 / ETH1_RXD3 / PHYLINK0 / SDA1 / MDAT2
166	PB0 / ETH1_RXDV / MTCLKB / TCLKD / TIC3
167	PB1 / ETH1_RXER / MTCLKA / TCLKC / CTS4#
168	PB2 / ETH1_RXC / ETH0_RXD1 / MTIOC1A / SSL30 / MDAT1
169	VCCQ33
170	PB3 / IRQ3 / CS1# / ETH1_CRS / PHYRESETOUT# / TXD3 / CTXD1 / MCLK0
171	PB4 / A24 / ETH1_COL / ETH0_RXER / RXD3 / MOSI3 / MDAT0
172	PB5 / ETH_MDIO / TCLKB / POE0# / POE10# / CTS3# / RSPCK3
173	VSS
174	VDD
175	PB6 / ETH_MDC / TCLKA / SCK3 / RTS4# / MISO3
176	PC2 / ETH0_TXC / ETH1_RXD2 / SDA0

**Table 1.7 List of Pin and Pin Functions (320-Pin FBGA) (1 / 10)**

Pin Number	Power Supply Clock System Control	I/O Port	Bus	Timer (MTU3a, GPTa, TPUa, PPG, POE3, CMTW)	Communication (ETHERC, ECATC*1, SCIFA, RSP1a, RIICa, RSCAN, SPIBSC, USB)	Others (SSI, DSMIF, Encoder I/F)	Interrupt	S12ADCa
A1	VSS							
A2		PC2			ETH0_TXC / ETH1_RXD2 / CATI2CDATA / SDA0			
A3		PJ3			ETH0_TXD0		IRQ11	ADTRG0
A4		PJ1			ETH0_TXD2 / CATLEDSTER / RSPCK3			
A5		PF7	A25		ETH0_TXER / RTS3# / SSL30		IRQ7	
A6		PB4	A24		ETH1_COL / ETH0_RXER / CATSYNC0 / CATLATCH0 / RXD3 / MOSI3	MDAT0		
A7		PB0		MTCLKB / TCLKD / TIC3	ETH1_RXDV			
A8		PC0	WAIT#	GTETRG	ETH1_RXD2 / SCL1	MDAT3		
A9		PF6		MTIOC3D / GTIOC0B / TOC2	ETH1_RXD0			
A10	VCCQ33							
A11		P54			CLKOUT25M1 / MOSI2			
A12	VSS							
A13								AN007
A14								AN005
A15								AN002
A16	AVCC0							
A17	AVCC1							
A18	VREFH1							
A19		P17	CS5#		ETH1_TXER / PHYRESETOUT#			ADTRG0
A20	VSS							
B1		PJ5		TIOC0D	ETH0_RXD1 / RXD3			
B2		PJ4			ETH0_RXD0 / TXD3			
B3		PC3			ETH0_RXC / ETH0_RXDV / CATI2CCLK / RXD4 / SCL0 / CRXD1			
B4		PJ2			ETH0_TXD1 / MISO3		IRQ10	
B5		PJ0			ETH0_TXD3 / CATLEDERR / MOSI3		IRQ8	
B6		PB5		TCLKB / POE0# / POE10#	ETH_MDIO / CTS3# / RSPCK3			

Table 1.7 List of Pin and Pin Functions (320-Pin FBGA) (2 / 10)

Pin Number	Power Supply Clock System Control	I/O Port	Bus	Timer (MTU3a, GPTa, TPUa, PPG, POE3, CMTW)	Communication (ETHERC, ECATC*1, SCIFA, RSP1a, RIIa, RSCAN, SPIBSC, USB)	Others (SSI, DSMIF, Encoder I/F)	Interrupt	S12ADCa
B7		PB2		MTIOC1A	ETH1_RXC / ETH0_RXD1 / CATSYNC1 / CATLATCH1 / SSL30	MDAT1		
B8		PC1			ETH1_RXD3 / PHYLINK0 / SDA1	MDAT2	IRQ9	
B9		PB7		MTIOC3B / GTIOC0A / TOC3	ETH1_RXD1			
B10		P86		MTIOC4B / GTIOC2A / TOC1	ETH1_TXD0 / RSPCK2			AN1_ANE X0
B11		PD7		MTIOC4D / GTIOC2B / TOC0	ETH1_TXD1			AN115
B12		P52			ETH0_INT / SSL20			
B13								AN006
B14								AN003
B15								AN001
B16	AVSS0							
B17	AVSS1							
B18	VREFL1							
B19		P16	CS4# / CS2#	MTIOC3B / GTIOC0A		ENCIF12		
B20		P15	CS3# / CKE	MTIOC3D / GTIOC0B		ENCIF11		
C1		PJ7			ETH0_RXD3 / CATLEDRUN / CTS3#		IRQ15	
C2		PJ6			ETH0_RXD2 / CATIRQ / SCK3		IRQ14	
C3		PU2		TIOC09	ETH2_CRS / RXD3		IRQ2	
C4		PL7			ETH2_RXDV		IRQ15	
C5		PL5		TIOCA8	ETH2_RXD2			
C6		PB6		TCLKA	ETH_MDC / SCK3 / RTS4# / MISO3			
C7		PB3	CS1#		ETH1_CRS / PHYRESETOUT# / TXD3 / CTXD1	MCLK0	IRQ3	
C8		PB1		MTCLKA / TCLKC	ETH1_RXER / CTS4#			
C9		PF5		MTIOC4A / GTIOC1A / TIC2	ETH1_TXEN			
C10		P87	A23	MTIOC4C / GTIOC1B	ETH1_TXC / ETH0_RXD0	MCLK1		AN1_ANE X1
C11		PD6	A22	TIC1	ETH1_TXD2 / ETH0_TXD1 / MISO2	MCLK2		AN114
C12		P53			ETH1_INT / MISO2			
C13		P51			PHYLINK1 / RSPCK2		IRQ1	
C14								AN004

Table 1.7 List of Pin and Pin Functions (320-Pin FBGA) (3 / 10)

Pin Number	Power Supply Clock System Control	I/O Port	Bus	Timer (MTU3a, GPTa, TPUa, PPG, POE3, CMTW)	Communication (ETHERC, ECATC*1, SCIFA, RSPIa, RIICa, RSCAN, SPIBSC, USB)	Others (SSI, DSMIF, Encoder I/F)	Interrupt	S12ADCa
C15								AN000
C16	VREFL0							
C17	VREFH0							
C18		PD2	WAIT#					AN110
C19		P14	CAS#	MTIOC4A / GTIOC1A			ENCIF10	
C20		P13	RAS#	MTIOC4C / GTIOC1B				
D1		P81		TIOCC0	ETH0_RXER / CTS4#			
D2		P80		TIOCC3	ETH0_RXDV / RTS4#		IRQ8	
D3		PU3		TIOCD6	ETH2_COL / TXD3			
D18		PD0	CS4#					AN108
D19		P96		POE0# / POE10#			ENCIF09	AN106
D20		P95		MTCLKA	CTS2#		IRQ13	AN105
E1		P84			ETH0_COL / CATLINKACT1 / RXD4			
E2		P82		TIOCD3	ETH0_TXEN / ETH1_CRS / SCK4 / RTS3# / USB_OVRCUR			
E3		PU1		TIOCA11	ETH2_RXC / SCK3			
E5		PU0		TIOCA10	ETH2_RXER			
E6		PL6		TIOCA9	ETH2_RXD3			
E7		PL4			ETH2_RXD1		IRQ4	
E8		PL2		TIOCA6	ETH2_TXEN			ADTRG1
E9		PL0		TIOCB9	ETH2_TXD0			
E10		PK7		TIOCB7	ETH2_TXD2			
E11		PK6		TIOCB6	ETH2_TXD3			
E12		PD5	A21	TIC0	ETH1_TXD3 / ETH0_TXD0 / SSL20		MCLK3	AN113
E13		P56	BS#		ETH1_TXER			
E14		PD4			ETH2_INT			AN112
E15	VCCQ33							
E16		PD1	CS1#					AN109
E18		P97	A25				IRQ7	ADTRG1 / AN107
E19		P94		MTCLKB	RTS2#		ENCIF08	IRQ4
E20		P93		MTIOC1A / TIC3	SCK2		ENCIF07	AN103
F1		PC4		TCLKH	CATI2CCLK / SCL0			
F2		P83			ETH0_CRS / CATLINKACT0 / TXD4		IRQ11	

Table 1.7 List of Pin and Pin Functions (320-Pin FBGA) (4 / 10)

Pin Number	Power Supply Clock System Control	I/O Port	Bus	Timer (MTU3a, GPTa, TPUa, PPG, POE3, CMTW)	Communication (ETHERC, ECATC*1, SCIFA, RSP1a, RIIa, RSCAN, SPIBSC, USB)	Others (SSI, DSMIF, Encoder I/F)	Interrupt	S12ADCa
F3		P85			CLKOUT25M0 / TXD4 / SCK4 / USB_VBUSEN		IRQ5	
F5		PU4		TIOCC9	MII2_MDC / CTS3#			
F6	VSS							
F7	VCCQ33							
F8		PL3		TIOCA7	ETH2_RXD0			
F9		PL1		TIOCB10	ETH2_TXC			
F10		PK5		TIOCB8	ETH2_TXD1			
F11		PK4		TIOCB11	ETH2_TXER / MOSI2			
F12		P55	A24		ETHSWSECOUT		IRQ5	
F13		P50	CS1#		PHYLINK0		IRQ8	
F14		PD3			PHYRESETOUT2#			AN111
F15		PK2	A23					
F16		P90	RAS#	TIOCA5	TXD4			AN100
F18		P92	CS5#	TOC3	RXD2			AN102
F19		P91	CAS#		TXD2	ENCIF06		AN101
F20		P12		MTIOC4B / GTIOC2A				
G1		PU6		TCLKF	PHYRESETOUT# / CTS4#			
G2		PC5		TCLKG	CAT12CDATA / SDA0			
G3	VCCQ33							
G5		PU5		TIOCC6	MII2_MDIO / RTS3#		IRQ13	
G6		PM0			CLKOUT25M2 / TXD4			
G15		PK3	A24					
G16		PA7	D31 / A22	MTIOC6B / GTIOC3B	RTS2#	MCLK0	IRQ7	
G18		PA4	D28 / TEND2	TIOCA3	ETH1_INT / RXD2	MDAT1		ADTRG0
G19		PA3	D27 / DACK2	GTETRG / TIOCA2	ETHSWSECOUT / SCK2	MCLK2		
G20		P11		MTIOC4D / GTIOC2B			IRQ9	
H1		PU7			CATIRQ / RXD4			
H2		PM1			CATLEDERR / SCK4			
H3		P35					NMI	
H5	ERROROUT#							
H6	VCCQ33							
H8	VDD							
H9	VDD							
H10	VDD							
H11	VDD							

**Table 1.7 List of Pin and Pin Functions (320-Pin FBGA) (5 / 10)**

Pin Number	Power Supply Clock System Control	I/O Port	Bus	Timer (MTU3a, GPTa, TPUa, PPG, POE3, CMTW)	Communication (ETHERC, ECATC*1, SCIFA, RSP1a, RIICa, RSCAN, SPIBSC, USB)	Others (SSI, DSMIF, Encoder I/F)	Interrupt	S12ADCa
H12	VDD							
H13	VSS							
H15		PA6	D30 / A21	GTIOC3A	CTS2#	MDAT0	IRQ6	
H16		PA5	D29	TIOCA4	ETH0_INT / ETH1_TXER / TXD2	MCLK1		
H18		PA2	D26 / DREQ2	MTIOC3B / GTIOC0A	SSL02	MDAT2 / ENCIF05		
H19		PK0	CAS#	PO31		ENCIF11		
H20		PK1	CS5#			ENCIF12		
J1		PM6		PO19	CATLINKACT0		IRQ6	
J2		PM3		PO16	CATSYNC0 / CATLATCH0			
J3		PM2		TCLKE	CATSYNC1 / CATLATCH1 / RTS4#			
J5	TDO	P33						
J6	TRST#							
J8	VDD							
J9	VSS							
J10	VSS							
J11	VSS							
J12	VSS							
J13	VDD							
J15	VCCQ33							
J16	TRACEDATA7	PA1	D25	MTIOC3D / GTIOC0B	MISO0	AUDIO_CLK / MCLK3		
J18	TRACEDATA6	PA0	D24	MTIOC4A / GTIOC1A	MOSIO	MDAT3		
J19		PT7	A22 / DACK2			ENCIF10		
J20		PT6	A21 / DREQ2					
K1		PM7		PO20	CATLINKACT1			
K2		PM5		PO18	CATLEDSTER			
K3		PM4		PO17	CATLEDRUN			
K5	TDI	P34						
K6	PLLVD1							
K8	VDD							
K9	VSS							
K10	VSS							
K11	VSS							
K12	VSS							
K13	VDD							
K15	VSS							
K16	TRACEDATA5	P77	D23	MTIOC4C / GTIOC1B	RSPCK0			

**Table 1.7 List of Pin and Pin Functions (320-Pin FBGA) (6 / 10)**

Pin Number	Power Supply Clock	I/O Port	Bus	Timer	Communication	Others	
				(MTU3a, GPTa, TPUa, PPG, POE3, CMTW)	(ETHERC, ECATC*1, SCIFA, RSP1a, RIIa, RSCAN, SPIBSC, USB)	(SSI, DSMIF, Encoder I/F)	Interrupt
K18	TRACEDATA4	P76	D22	MTIOC4B / GTIOC2A	SSL01	SSIWS0	
K19	TRACEDATA3	P75	D21	MTIOC4D / GTIOC2B	SSL00	ENCIF04	IRQ13
K20		PT5	BS# / TEND2	PO30			
L1	MD1						
L2	MD2						
L3	TMS						
L5	TCK						
L6	PLLVSS1						
L8	VDD						
L9	VSS						
L10	VSS						
L11	VSS						
L12	VSS						
L13	VDD						
L15	VSS						
L16	TRACEDATA7	PE7	D15	MTIOC7A / TIOC3 / POE8#	SCK1 / RSPCK0		
L18	TRACEDATA0	P72	D18	MTIOC1A / TIC2	TXD1	SSITXD0 / ENCIF02	
L19	TRACEDATA1	P73	D19	MTCLKB	RXD1	SSIRXD0 / ENCIF03	
L20	TRACEDATA2	P74	D20	MTCLKA	CTS1# / SSL03	SSISCK0	
M1	XTAL						
M2	EXTAL						
M3	OSCTH						
M5	BSCANP						
M6	PLLVDD0						
M8	VDD						
M9	VSS						
M10	VSS						
M11	VSS						
M12	VSS						
M13	VDD						
M15	VCCQ33						
M16	TRACEDATA6	PE6	D14	MTIOC0A / TIOC0	RXD1 / MISO0	IRQ6	
M18	TRACECLK	P70	D16	MTIOC6D	RTS1# / USB_OVRCUR	ENCIF00	IRQ0
M19		PT4	CS3#	PO29			
M20	TRACECTL	P71	D17	POE0# / POE10# / TOC2	SCK1	ENCIF01	
N1	VSS						
N2	MD0						

**Table 1.7 List of Pin and Pin Functions (320-Pin FBGA) (7 / 10)**

Pin Number	Power Supply Clock	System Control	I/O Port	Bus	Timer	Communication	Others
					(MTU3a, GPTa, TPUa, PPG, POE3, CMTW)	(ETHERC, ECATC*1, SCIFA, RSP1a, RIIa, RSCAN, SPIBSC, USB)	(SSI, DSMIF, Encoder I/F) Interrupt S12ADCa
N3	RSTOUT#						
N5	RES#						
N6	PLLVSS0						
N8	VDD						
N9	VSS						
N10	VDD						
N11	VDD						
N12	VDD						
N13	VDD						
N15	TRACEDATA2	PE2	D10		MTCLKC / TIOCB4	SSL02	IRQ2
N16	TRACEDATA4	PE4	D12		MTIOC0B / TIOCC0	RTS1# / SSL00	
N18	TRACEDATA5	PE5	D13		MTIOC0C / TIOCC3	TXD1 / MOSI0	
N19		PT2			TIOCA1 / TIOCB1 / PO27		
N20		PT3			TIOCA0 / TIOCB0 / PO28	CTS2#	ENCIF09 IRQ11
P1	VSS_USB						
P2	VDD33_USB						
P3	USB_RREF						
P5		P31				USB_VBUSEN	
P6	VCCQ33						
P15		P06	D6		MTIOC2B / TIOCB0		
P16		P07	D7		MTIOC2A / TIOCB1		
P18	TRACEDATA3	PE3	D11		MTIOC0D / TIOCB5	CTS1# / SSL01	IRQ3
P19		PT0			TIOCA3 / TIOCB3 / PO25	SCK2	ENCIF07 IRQ0
P20		PT1			TIOCA2 / TIOCB2 / PO26	RTS2#	ENCIF08
R1	USB_DP						
R2	USB_DM						
R3		P30				CRXD0 / USB_VBUSIN	
R5		PN0			MTIOC8D	SSL10	
R6		PN2			MTIOC8B	MOSI1	IRQ10
R7		PG0	A1		PO2		
R8		PG2	A3		PO4 / TOC0	RSPCK1	
R9		PG7	A8		PO9		
R10		PH2	A11		MTIOC2A / PO12		
R11		PH4	A13		PO14		IRQ4
R12		PH6	A15		MTIOC7D	RTS0#	
R13		P23	A0 / DACK1		MTIC5U	TXD0	
R14		P27	A20		MTIOC8C / TIOCB0	RTS0#	
R15		P47	WE3# / DQM0U / AH#		MTIOC6C		



**Table 1.7 List of Pin and Pin Functions (320-Pin FBGA) (8 / 10)**

Pin Number	Power Supply Clock	I/O Port	Bus	Timer (MTU3a, GPTa, TPUa, PPG, POE3, CMTW)	Communication (ETHERC, ECATC*1, SCIFA, RSP1a, R1ICa, RSCAN, SPIBSC, USB)	Others (SSI, DSMIF, Encoder I/F)	Interrupt	S12ADCa
R16	VCCQ33							
R18	VCCQ33							
R19		PS6		TIOCA5 / TIOCB5 / PO23	RXD2	ENCIF06	IRQ14	
R20		PS7		TIOCA4 / TIOCB4 / PO24	TXD2			
T1	DVDD_USB							
T2	VDD33_USB							
T3		P32			USB_OVRCUR		IRQ10	
T5		PC6	DREQ0	TCLKC	SCL1 / CRXD0 / USB_VBUSIN			
T6		P37	WE1# / DQMLU	PO1				
T7		P36	WE0# / DQMLL	PO0				
T8		PG3	A4	PO5 / TIC1	MISO1			
T9		PG6	A7	TCLKB / PO8	SSL11			
T10		PH3	A12	MTIOC1B / PO13				
T11	VCCQ33							
T12		PH5	A14	PO15				
T13	VCCQ33							
T14		P26	A19 / DREQ1	MTIOC8D				
T15	VCCQ33							
T16	VSS							
T18	VSS							
T19	TRACEDATA0	PE0	D8	MTIOC1B / TIOCB2				
T20	TRACEDATA1	PE1	D9	MTCLKD / TIOCB3	SSL03			
U1		P60	TEND0		CTXD0 / SPBSSL			
U2		P63			SPBMO / SPBIO0			
U3		PN1		MTIOC8C / PO21	MISO1	ENCIF09		
U18	TRACECTL	P00	D0	MTIOC6A / TIOCA1				ADTRG1
U19		P04	D4	MTIOC3C / TIOCA5				
U20		P03	D3	MTIC5U / TIOCA4				
V1		P61	DACK0		CTXD1 / SPBIO3			
V2		P64			SPBMI / SPBIO1			
V3		PN3		MTIOC8A	RSPCK1			
V4		PN4		MTIOC6C / TIOCC6	SSL11		IRQ12	
V5		PC7		TIC0	SDA1 / CRXD1			
V6		PG1	A2	PO3				
V7		PG4	A5	PO6 / TOC1	MOSI1			
V8		PG5	A6	TCLKA / PO7	SSL10			
V9		PH0	A9	PO10				
V10		PH1	A10	MTIOC2B / PO11				
V11		PH7	A16	MTIC5W				

Table 1.7 List of Pin and Pin Functions (320-Pin FBGA) (9 / 10)

Pin Number	Power Supply Clock System Control	I/O Port	Bus	Timer (MTU3a, GPTa, TPUa, PPG, POE3, CMTW)	Communication (ETHERC, ECATC*1, SCIFA, RSPIa, RIIa, RSCAN, SPIBSC, USB)	Others (SSI, DSMIF, Encoder I/F)	Interrupt	S12ADCa
V12		P20	A17	MTCLKD				
V13		P21	CS0#	MTIC5V / TIOCB1	CTS0#		IRQ1	
V14	VSS							
V15		P45	CS2#					
V16		P46	CKE					
V17		PS2		MTIOC7C		SSIWS0		
V18		P05	D5	MTIOC3A				
V19		P01	D1	MTIC5W / TIOCA2				
V20		P02	D2	MTIC5V / TIOCA3				
W1		P62			SPBCLK			
W2		P65	DREQ0		SPBIO2			
W3		PN5		MTIOC6A / TIOCD9		ENCIF10	IRQ5	
W4		PN6		MTIOC3C / TIOCC9		MCLK3 / ENCIF11		
W5		PP0	TEND0	POE8#		MCLK2		
W6		PP2		MTIOC0C / TCLKH		MCLK1		
W7		PP4		MTIOC0A		MCLK0		
W8	TRACECTL	PP6		TIOCA11	RXD1	ENCIF06		
W9	TRACECLK	PP7	DACK1	TCLKF / TCLKH	SCK1			
W10	TRACEDATA1	PR1	TEND1	POE4#	CTS1#	ENCIF08	IRQ9	
W11	TRACEDATA3	PR3		TIOCA10 / TIOCB10		ENCIF01		
W12	TRACEDATA5	PR5		TIOCA8 / TIOCB8		ENCIF03		
W13		P24	RD/WR#		RXD0		IRQ12	
W14		P22	RD#	MTIOC7B / TIOCD0	SCK0		IRQ2	
W15		P44	WAIT#	TCLKD	CTS0#		IRQ12	ADTRG0
W16		P43	WE2# / DQMUL	MTIOC8B	USB_VBUSEN			
W17		PS1		MTIOC7B		SSISCK0	IRQ1	
W18		PS3		MTIOC7A		SSIRXD0		
W19		PS4		MTIOC6D		SSITXD0		
W20		PS5		MTIOC6B				
Y1	VSS							
Y2		P67	TEND0	GTIOC3B	CTXD0 / USB_OVRCUR		IRQ15	
Y3		P66	DACK0	GTIOC3A	CTXD1 / USB_VBUSEN		IRQ14	
Y4		PN7	DREQ0	MTIOC3A / TIOCD6		MDAT3 / ENCIF12		
Y5		PP1	DACK0	MTIOC0D		MDAT2		
Y6		PP3		MTIOC0B / TCLKC		MDAT1		
Y7		PP5		PO22		MDAT0		
Y8	VSS							
Y9	TRACEDATA0	PR0	DREQ1	TCLKE / TCLKG	TXD1	ENCIF07		
Y10	TRACEDATA2	PR2		TIOCA11 / TIOCB11	RTS1#	ENCIF00		

**Table 1.7 List of Pin and Pin Functions (320-Pin FBGA) (10 / 10)**

Pin Number	Power Supply Clock	I/O Port	Bus	Timer (MTU3a, GPTa, TPUa, PPG, POE3, CMTW)	Communication (ETHERC, ECATC*1, SCIFA, RSP1a, RIICa, RSCAN, SPIBSC, USB)	Others (SSI, DSMIF, Encoder I/F) Interrupt S12ADCa
Y11	TRACEDATA4	PR4		TIOCA9 / TIOCB9		ENCIF02
Y12	TRACEDATA6	PR6		TIOCA7 / TIOCB7		ENCIF04
Y13	TRACEDATA7	PR7		TIOCA6 / TIOCB6		ENCIF05
Y14		P25	A18 / TEND1	MTCLKC		
Y15		P41	BS#		SCK0	
Y16		P42		MTIOC7C	RXD0	
Y17		P40		MTIOC8A	TXD0	
Y18		PS0		MTIOC7D		AUDIO_CLK
Y19	TRACECLK	P10	CKIO	TIOCA0		IRQ0
Y20	VSS					

Note 1. Optional

Table 1.8 List of Pin and Pin Functions (176-Pin HLQFP) (1 / 6)

Pin Number	Power Supply Clock System Control	I/O Port	Bus	Timer (MTU3a, GPTa, TPUa, PPG, POE3, CMTW)	Communication (ETHERC, SCIFA, RSPIa, RIICa, RSCAN, SPIBSC, USB)	Others (SSI, DSMIF) Interrupt S12ADCa
1		PC3			ETH0_RXC / ETH0_RXDV / RXD4 / SCL0 / CRXD1	
2	VCCQ33					
3	VSS					
4	VDD					
5		P82		TIOCD3	ETH0_TXEN / ETH1_CRS / SCK4 / RTS3# / USB_OVRCUR	
6		P85			CLKOUT25M0 / TXD4 / SCK4 / USB_VBUSEN	IRQ5
7	ERROROUT #					
8		P35				NMI
9	TRST#					
10	TDO	P33				
11	TDI	P34				
12	TMS					
13	TCK					
14	BSCANP					
15	VDD					
16	VSS					
17	MD2					
18	MD1					
19	PLLVD1					
20	PLLVS1					
21	OSC1H					
22	VCCQ33					
23	EXTAL					
24	XTAL					
25	VSS					
26	MD0					
27	PLLVD0					
28	PLLVS0					
29	RES#					
30	RSTOUT#					
31	VDD					
32	VSS					
33	VDD33_USB					
34	VSS_USB					
35	USB_RREF					

Table 1.8 List of Pin and Pin Functions (176-Pin HLQFP) (2 / 6)

Pin Number	Power Supply Clock System Control	I/O Port	Bus	Timer (MTU3a, GPTa, TPUa, PPG, POE3, CMTW)	Communication (ETHERC, SCIFA, RSPIa, RIICa, RSCAN, SPIBSC, USB)	Others		
						(SSI, DSMIF)	Interrupt	S12ADCa
36	USB_DM							
37	USB_DP							
38	VDD33_USB							
39	DVDD_USB							
40		P30			CRXD0 / USB_VBUSIN			
41		P60	TEND0		CTXD0 / SPBSSL			
42		P61	DACK0		CTXD1 / SPBIO3			
43	VCCQ33							
44		P62			SPBCLK			
45	VSS							
46		P63			SPBMO / SPBIO0			
47		P64			SPBMI / SPBIO1			
48		P65	DREQ0		SPBIO2			
49	VSS							
50	VDD							
51		P36	WE0# / DQMLL	PO0				
52		P37	WE1# / DQMLU	PO1				
53		PG0	A1	PO2				
54		PG1	A2	PO3				
55	VCCQ33							
56		PG2	A3	PO4 / TOC0	RSPCK1			
57		PG3	A4	PO5 / TIC1	MISO1			
58		PG4	A5	PO6 / TOC1	MOSI1			
59		PG5	A6	TCLKA / PO7	SSL10			
60		PG6	A7	TCLKB / PO8	SSL11			
61		PG7	A8	PO9				
62		PH0	A9	PO10				
63		PH1	A10	MTIOC2B / PO11				
64		PH2	A11	MTIOC2A / PO12				
65		PH3	A12	MTIOC1B / PO13				
66	VDD							
67	VSS							
68		PH4	A13	PO14				IRQ4
69		PH5	A14	PO15				
70		PH6	A15	MTIOC7D	RTS0#			
71		PH7	A16	MTIC5W				
72		P24	RD/WR#		RXD0			IRQ12
73		P21	CS0#	MTIC5V / TIOCB1	CTS0#			IRQ1
74		P22	RD#	MTIOC7B / TIOCDO	SCK0			IRQ2

Table 1.8 List of Pin and Pin Functions (176-Pin HLQFP) (3 / 6)

Pin Number	Power Supply Clock System Control	I/O Port	Bus	Timer (MTU3a, GPTa, TPUa, PPG, POE3, CMTW)	Communication (ETHERC, SCIFA, RSPIa, RIICa, RSCAN, SPIBSC, USB)	Others (SSI, DSMIF) Interrupt S12ADCa
75		P23	A0 / DACK1	MTIC5U	TXD0	
76		P20	A17	MTCLKD		
77		P25	A18 / TEND1	MTCLKC		
78		P26	A19 / DREQ1	MTIOC8D		
79		P27	A20	MTIOC8C / TIOCB0	RTS0#	
80	VDD					
81	VSS					
82		P42		MTIOC7C	RXD0	
83		P40		MTIOC8A	TXD0	
84		P43	WE2# / DQMUL	MTIOC8B	USB_VBUSEN	
85		P47	WE3# / DQMUU/AH#	MTIOC6C		
86	VCCQ33					
87	TRACECLK	P10	CKIO	TIOCA0		IRQ0
88	VSS					
89	TRACECTL	P00	D0	MTIOC6A / TIOCA1		
90		P01	D1	MTIC5W / TIOCA2		
91		P02	D2	MTIC5V / TIOCA3		
92	VCCQ33					
93		P03	D3	MTIC5U / TIOCA4		
94		P04	D4	MTIOC3C / TIOCA5		
95		P05	D5	MTIOC3A		
96		P06	D6	MTIOC2B / TIOCB0		
97		P07	D7	MTIOC2A / TIOCB1		
98	TRACEDATA 0	PE0	D8	MTIOC1B / TIOCB2		
99	TRACEDATA 1	PE1	D9	MTCLKD / TIOCB3	SSL03	
100	VSS					
101	TRACEDATA 2	PE2	D10	MTCLKC / TIOCB4	SSL02	IRQ2
102	TRACEDATA 3	PE3	D11	MTIOC0D / TIOCB5	CTS1# / SSL01	IRQ3
103	TRACEDATA 4	PE4	D12	MTIOC0B / TIOCC0	RTS1# / SSL00	
104	TRACEDATA 5	PE5	D13	MTIOC0C / TIOCC3	TXD1 / MOSI0	
105	TRACEDATA 6	PE6	D14	MTIOC0A / TIOCD0	RXD1 / MISO0	IRQ6

Table 1.8 List of Pin and Pin Functions (176-Pin HLQFP) (4 / 6)

Pin Number	Power Supply Clock System Control	I/O Port	Bus	Timer (MTU3a, GPTa, TPUa, PPG, POE3, CMTW)	Communication (ETHERC, SCIFA, RSPIa, RIICa, RSCAN, SPIBSC, USB)	Others		
						(SSI, DSMIF)	Interrupt	S12ADCa
106	TRACEDATA 7	PE7	D15	MTIOC7A / TIOCD3 / POE8#	SCK1 / RSPCK0			
107	VSS							
108	VDD							
109	TRACECLK	P70	D16	MTIOC6D	RTS1# / USB_OVRCUR		IRQ0	
110	TRACECTL	P71	D17	POE0# / POE10# / TOC2	SCK1			
111	TRACEDATA 0	P72	D18	MTIOC1A / TIC2	TXD1		SSITXD0	
112	TRACEDATA 1	P73	D19	MTCLKB	RXD1		SSIRXD0	IRQ3
113	TRACEDATA 2	P74	D20	MTCLKA	CTS1# / SSL03		SSISCK0	
114	TRACEDATA 3	P75	D21	MTIOC4D / GTIOC2B	SSL00			IRQ13
115	TRACEDATA 4	P76	D22	MTIOC4B / GTIOC2A	SSL01		SSIWS0	
116	TRACEDATA 5	P77	D23	MTIOC4C / GTIOC1B	RSPCK0			
117	TRACEDATA 6	PA0	D24	MTIOC4A / GTIOC1A	MOSI0		MDAT3	
118	TRACEDATA 7	PA1	D25	MTIOC3D / GTIOC0B	MISO0		AUDIO_CLK / MCLK3	
119	VSS							
120	VDD							
121		PA2	D26 / DREQ2	MTIOC3B / GTIOC0A	SSL02		MDAT2	
122		PA3	D27 / DACK2	GTETRG / TIOCA2	ETHSWSECOUT / SCK2		MCLK2	
123		PA4	D28 / TEND2	TIOCA3	ETH1_INT / RXD2		MDAT1	ADTRG0
124		PA5	D29	TIOCA4	ETH0_INT / ETH1_TXER / TXD2		MCLK1	
125		PA6	D30 / A21	GTIOC3A	CTS2#		MDAT0	IRQ6
126	VCCQ33							
127		PA7	D31 / A22	MTIOC6B / GTIOC3B	RTS2#		MCLK0	IRQ7
128	VDD							
129	VSS							
130		P13	RAS#	MTIOC4C / GTIOC1B				
131		P14	CAS#	MTIOC4A / GTIOC1A				
132		P15	CS3# / CKE	MTIOC3D / GTIOC0B				
133		P16	CS4# / CS2#	MTIOC3B / GTIOC0A				

**Table 1.8 List of Pin and Pin Functions (176-Pin HLQFP) (5 / 6)**

Pin Number	Power Supply Clock System Control	I/O Port		Timer (MTU3a, GPTa, TPUa, PPG, POE3, CMTW)	Communication (ETHERC, SCIFA, RSPIa, RIICa, RSCAN, SPIBSC, USB)	Others		
		Port	Bus			(SSI, DSMIF)	Interrupt	S12ADCa
134		P17	CS5#		ETH1_TXER / PHYRESETOUT#			ADTRG0
135	VCCQ33							
136	VREFH0							
137	VREFL0							
138	AVSS0							
139	AVCC0							
140								AN000
141								AN001
142								AN002
143								AN003
144								AN004
145								AN005
146								AN006
147								AN007
148	VDD							
149	VSS							
150		P51			PHYLINK1 / RSPCK2			IRQ1
151		P54			CLKOUT25M1 / MOSI2			
152		P56	BS#		ETH1_TXER			
153		PD5	A21	TIC0	ETH1_TXD3 / ETH0_TXD0 / SSL20			MCLK3
154		PD6	A22	TIC1	ETH1_TXD2 / ETH0_TXD1 / MISO2			MCLK2
155		PD7		MTIOC4D / GTIOC2B / TOC0	ETH1_TXD1			
156		P86		MTIOC4B / GTIOC2A / TOC1	ETH1_TXD0 / RSPCK2			
157		P87	A23	MTIOC4C / GTIOC1B	ETH1_TXC / ETH0_RXD0			MCLK1
158		PF5		MTIOC4A / GTIOC1A / TIC2	ETH1_TXEN			
159	VCCQ33							
160	VDD							
161	VSS							
162		PF6		MTIOC3D / GTIOC0B / TOC2	ETH1_RXD0			
163		PB7		MTIOC3B / GTIOC0A / TOC3	ETH1_RXD1			
164		PC0	WAIT#	GTETRG	ETH1_RXD2 / SCL1			MDAT3



**Table 1.8 List of Pin and Pin Functions (176-Pin HLQFP) (6 / 6)**

Pin Number	Power Supply Clock System Control	I/O Port	Bus	Timer (MTU3a, GPTa, TPUa, PPG, POE3, CMTW)	Communication (ETHERC, SCIFA, RSPIa, RIICa, RSCAN, SPIBSC, USB)	Others (SSI, DSMIF) Interrupt S12ADCa
165		PC1			ETH1_RXD3 / PHYLINK0 / SDA1	MDAT2 IRQ9
166		PB0		MTCLKB / TCLKD / TIC3	ETH1_RXDV	
167		PB1		MTCLKA / TCLKC	ETH1_RXER / CTS4#	
168		PB2		MTIOC1A	ETH1_RXC / ETH0_RXD1 / SSL30	MDAT1
169	VCCQ33					
170		PB3	CS1#		ETH1_CRS / PHYRESETOUT# / TXD3 / CTXD1	MCLK0 IRQ3
171		PB4	A24		ETH1_COL / RXD3 / MOSI3 / ETH0_RXER	MDAT0
172		PB5		TCLKB / POE0# / POE10#	ETH_MDIO / CTS3# / RSPCK3	
173	VSS					
174	VDD					
175		PB6		TCLKA	ETH_MDC / SCK3 / RTS4# / MISO3	
176		PC2			ETH0_TXC / ETH1_RXD2 / SDA0	

## 2. Electrical Characteristics

### 2.1 Absolute Maximum Ratings

**Table 2.1 Absolute Maximum Rating**

Conditions: VSS = PLLVSS0 = PLLVSS1 = AVSS0 = AVSS1 = VREFL0 = VREFL1 = VSS\_USB = 0 V

Item	Symbol	Value	Unit
Power supply voltage (I/O)	VCCQ33	-0.3 to +4.2	V
Power supply voltage (internal)	VDD	-0.3 to +1.6	V
PLL power supply voltage	PLLVDD0, PLLVDD1	-0.3 to +1.6	V
Input voltage (except for ports for 5-V tolerant*1)	V <sub>in1</sub>	-0.3 to VCCQ33 + 0.3*5	V
Input voltage (ports for 5-V tolerant*1)	V <sub>in2</sub>	-0.3 to +5.5*3	V
Analog power supply voltage	AVCC0, AVCC1*2	-0.3 to +4.2	V
Reference power supply voltage	VREFH0, VREFH1	-0.3 to (AVCC0, AVCC1) + 0.3*5	V
USB digital power supply voltage	DVDD_USB	-0.3 to +1.6	V
USB power supply voltage	VDD33_USB*2	-0.3 to +4.2	V
Analog input voltage	V <sub>AN</sub>	-0.3 to (AVCC0, AVCC1) + 0.3*5	V
Operating temperature (junction temperature)	T <sub>j</sub> *4	-40 to +125	°C
Storage temperature	T <sub>stg</sub>	-55 to +125	°C

[Usage Notes]

- Do not directly connect output pins (I/O pins in output state) of IC products to other output pins (including I/O pins in output state), power pins, or GND pins. However, output pins are directly connectable in an external circuit where timing design is provided to avoid conflict of outputs of high-impedance pins such as I/O pins.
- If even a single item exceeds the absolute maximum rating for even a moment, it may degrade the product's quality. In other words, the absolute maximum rating is a rated value that potentially causes physical damage to products. Use products with a margin of the absolute maximum rating.  
Specified values and conditions shown in DC characteristics and AC characteristics are the range of normal operation and quality assurance of products.

Note 1. Ports PC0 to PC7 and P30 are 5-V tolerant.

Note 2. When the A/D converter unit 0 is not to be used, connect the AVCC0 and VREFH0 pins to VCCQ33 and the AVSS0 and VREFL0 pins to VSS, respectively. Do not leave these pins open. In the same way, when the A/D converter unit 1 is not to be used, connect the AVCC1 and VREFH1 pins to VCCQ33 and the AVSS1 and VREFL1 pins to VSS, respectively. Do not leave these pins open. When the USB is not to be used, connect the VDD33\_USB pin to VCCQ33, the VSS\_USB pin to VSS, and the DVDD\_USB pin to VDD, respectively. Do not leave these pins open.

Note 3. When VCCQ33 is less than 3.0 V, the rated value of ports for 5-V tolerant is 3.6 V.

Note 4. For operations at the temperatures over 110 °C (junction temperature), refer to the RZ/T1 Group Application Note: Precautions for High-Temperature Operations (R01AN3116).

Note 5. Do not exceed the absolute maximum rating, 4.2 V.

## 2.2 Power On/Off Sequence

Turn on and off each power supply voltage according to the procedure shown in the figure below.

When turning on the power, be sure to fix TRST# pins and RES# pins to the low level. Otherwise, initialization is not performed successfully.

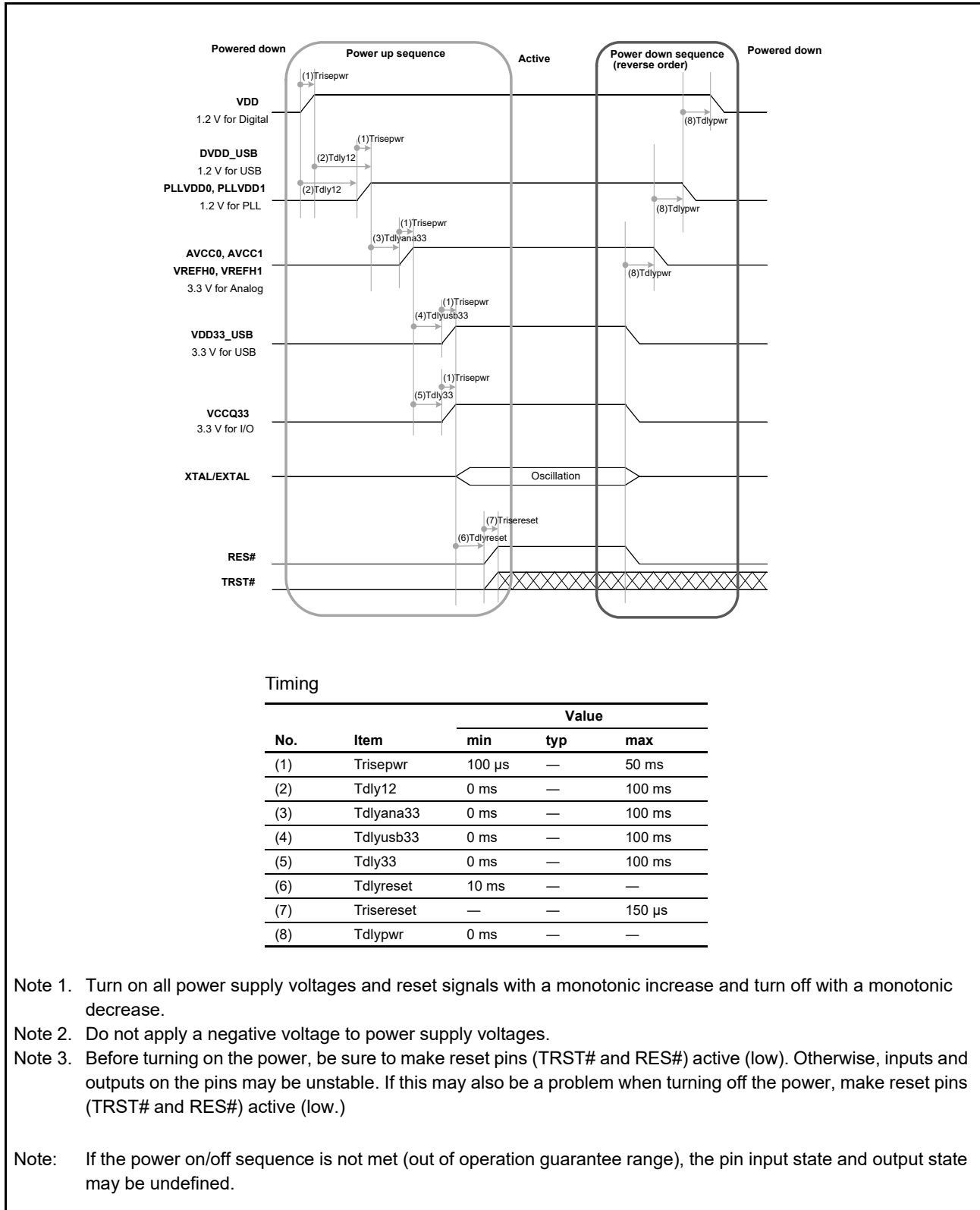

Figure 2.1 Power On/Off Sequence

### 2.3 DC Characteristics

- Conditions: VDD = PLLVDD0 = PLLVDD1 = DVDD\_USB = 1.14 to 1.26 V,  
VCCQ33 = AVCC0 = AVCC1 = VREFH0 = VREFH1 = VDD33\_USB = 3.0 to 3.6 V  
VSS = PLLVSS0 = PLLVSS1 = AVSS0 = AVSS1 = VREFL0 = VREFL1 = VSS\_USB = 0 V,  
Tj = -40 to 125°C

Note: The 176-pin HLQFP does not have pins AVCC1, AVSS1, VREFH1, and VREFL1.

**Table 2.2 DC Characteristics (1)**

Item	Symbol	min	typ	max	Unit	Test Conditions
Power supply voltage (I/O)	VCCQ33	3.0	3.3	3.6	V	
Power supply voltage (internal)	VDD	1.14	1.2	1.26	V	
PLL power supply voltage	PLLVDD0, PLLVDD1	1.14	1.2	1.26	V	
USB digital power supply voltage	DVDD_USB	1.14	1.2	1.26	V	
Analog power supply voltage	AVCC0, AVCC1	3.0	3.3	3.6	V	
USB power supply voltage	VDD33_USB	3.0	3.3	3.6	V	

**Table 2.3 DC Characteristics (2) [Power Supply] (1 / 2)**

Item	Type	Symbol	typ	max	Unit	Test Conditions	
Normal operation	VDD	600MHz	Vlcc	330	820	mA	Tj = -40 to 125 °C (R7S910018CBG, R7S910118CBG)
				273	752	mA	Tj = -40 to 125 °C (R7S910017CBG, R7S910117CBG)
				265	740	mA	Tj = -40 to 125 °C (R7S910028CBG, R7S910128CBG)
				258	731	mA	Tj = -40 to 125 °C (R7S910013CBG, R7S910113CBG)
				209	673	mA	Tj = -40 to 125 °C (R7S910027CBG, R7S910127CBG)
				201	663	mA	Tj = -40 to 125 °C (R7S910007CBG, R7S910107CBG)
				310	798	mA	Tj = -40 to 125 °C (R7S910016CBG, R7S910116CBG)
				253	730	mA	Tj = -40 to 125 °C (R7S910015CBG, R7S910115CBG)
				245	718	mA	Tj = -40 to 125 °C (R7S910026CBG, R7S910126CBG)
				238	709	mA	Tj = -40 to 125 °C (R7S910011CBG, R7S910111CBG)
		189	651	mA	Tj = -40 to 125 °C (R7S910025CBG, R7S910125CBG)		
		181	641	mA	Tj = -40 to 125 °C (R7S910002CBG, R7S910006CBG, R7S910102CBG, R7S910106CBG)		
		180	640	mA	Tj = -40 to 125 °C (R7S910001CFP, R7S910101CFP)		
		300MHz	225	696	mA	Tj = -40 to 125 °C (R7S910036CBG, R7S910136CBG)	
			169	629	mA	Tj = -40 to 125 °C (R7S910035CBG, R7S910135CBG)	
		PLLVD0 + PLLVD1	PLLlcc	3.2	5	mA	
		VCCQ33	V33lcc	19*1, *2	—	mA	
		AVCC0	AV0lcc	2	5	mA	A/D conversion (unit 0)
		AVCC1	AV1lcc	0.7	1.5	mA	A/D conversion (unit 1)

**Table 2.3 DC Characteristics (2) [Power Supply] (2 / 2)**

Item	Type	Symbol	typ	max	Unit	Test Conditions
Normal operation	VREFH0	VRF0Icc	0.07	0.2	mA	A/D conversion (unit 0)
	VREFH1	VRF1Icc	0.07	0.2	mA	A/D conversion (unit 1)
	DVDD_USB	V12UIcc	5.1	9	mA	USB high-speed communication
			3.5	9	mA	USB full-speed communication
	VDD33_USB	V33UIcc	15 <sup>*1</sup>	—	mA	USB high-speed communication
			10 <sup>*1</sup>	—	mA	USB full-speed communication
Standby mode with all modules being inactive (reference value)	VDD	VIcc	41	—	mA	
	PLLVD0 + PLLVD1	PLLIcc	3.2	—	mA	
	VCCQ33	V33Icc	0.35 <sup>*1, *2</sup>	—	mA	
	AVCC0	AV0Icc	0.64	—	μA	
	AVCC1	AV1Icc	0.32	—	μA	
	VREFH0	VRF0Icc	0.24	—	μA	
	VREFH1	VRF1Icc	0.24	—	μA	
	DVDD_USB	V12UIcc	3.5	—	mA	UTMI suspend mode
	VDD33_USB	V33UIcc	9.6 <sup>*1</sup>	—	mA	UTMI suspend mode

Note 1. These values are reference values. The actual operating current greatly depends on the system (such as unsharpened waveforms due to I/O load and toggle frequency). Be sure to measure these current values in the system.

Note 2. V33Icc must be 80 mA or less. ( $\Sigma I_{OH}$  in Table 2.9)

**Table 2.4 DC Characteristics (3) [Except for USB2.0 Host/Function-Related Pins]**

Item		Symbol	min	typ	max	Unit	Test Conditions
Schmitt trigger Input voltage	Other than 5-V tolerant pins	$V_{IH1}$	2.4	—	$V_{CCQ33} + 0.3$	V	
		$V_{IL1}$	-0.3	—	0.8	V	
		$\Delta V_{T1}$	$V_{CCQ33}$ $\times 0.05$	—	—	V	
	5-V tolerant pins*1	$V_{IH2}$	$V_{CCQ33}$ $\times 0.7$	—	$5.3^{*2}$	V	
		$V_{IL2}$	-0.3	—	$V_{CCQ33} \times 0.3$	V	
		$\Delta V_{T2}$	$V_{CCQ33}$ $\times 0.05$	—	—	V	
Input high level voltage (except for schmitt trigger input pins)		$V_{IH3}$	2.4	—	$V_{CCQ33} + 0.3$	V	
Input low level voltage (except for schmitt trigger input pins)		$V_{IL3}$	-0.3	—	0.8	V	
Output high level voltage	Other than 5-V tolerant pins	$V_{OH}$	$V_{CCQ33}$ $- 0.5$	—	—	V	$I_{OH} = -2 \text{ mA}$
Output low level voltage	Other than 5-V tolerant pins	$V_{OL1}$	—	—	0.4	V	$I_{OL1} = 2 \text{ mA}$
	5-V tolerant pins*1	$V_{OL2}$	—	—	0.4	V	$I_{OL2} = 3 \text{ mA}$
			—	—	0.6	V	$I_{OL2} = 6 \text{ mA}$
Input leakage current		$ I_{in} $	—	—	1.0	$\mu\text{A}$	$V_{in1} = V_{in2} = 0 \text{ V}$ $V_{in1} = V_{in2} = V_{CCQ33}$
Three-state leakage current (off state)	Input/output and output pins excluding 5-V tolerant pins	$ I_{TS} $	—	—	1.0	$\mu\text{A}$	$V_{in1} = 0 \text{ V}$ $V_{in1} = V_{CCQ33}$
	5-V tolerant pins		—	—	5.0	$\mu\text{A}$	$V_{in2} = 0 \text{ V}$ $V_{in2} = V_{CCQ33}$
Input pull-up MOS current and resistance	Ports P50 to P56, P86 to P87, P90 to P97, PD0 to PD7	$I_{pu1}$	-300	—	-30	$\mu\text{A}$	$V_{CCQ33} = 3.0 \text{ to } 3.6 \text{ V}$ $V_{in1} = V_{in2} = 0 \text{ V}$
		$R_{pu1}$	10	—	120	$\text{k}\Omega$	
	Pins other than the above*3	$I_{pu2}$	-120	—	-7	$\mu\text{A}$	$V_{CCQ33} = 3.0 \text{ to } 3.6 \text{ V}$ $V_{in1} = V_{in2} = 0 \text{ V}$
		$R_{pu2}$	25	—	515	$\text{k}\Omega$	
Input pull-down MOS current and resistance	Ports P50 to P56, P86 to P87, P90 to P97, PD0 to PD7	$I_{pd1}$	30	—	300	$\mu\text{A}$	$V_{CCQ33} = 3.0 \text{ to } 3.6 \text{ V}$ $V_{in1} = V_{in2} = V_{CCQ33}$
		$R_{pd1}$	10	—	120	$\text{k}\Omega$	
	Pins other than the above*3	$I_{pd2}$	7	—	120	$\mu\text{A}$	$V_{CCQ33} = 3.0 \text{ to } 3.6 \text{ V}$ $V_{in1} = V_{in2} = V_{CCQ33}$
		$R_{pd2}$	25	—	515	$\text{k}\Omega$	
Pin capacity	All input/output and input pins	$C_{in}$	—	—	10	pF	

Note 1. Ports PC0 to PC7 and P30 are 5-V tolerant.

Note 2. When VCCQ33 is less than 3.00 V, do not apply voltage of 3.6 V or higher to 5-V tolerant pins.

Note 3. 5-V tolerant pins are not included.

**Table 2.5 DC Characteristics (4) [USB2.0 USB\_RREF Pin]**

Item	Symbol	min	typ	max	Unit	Test Conditions
Reference resistor	R <sub>REF</sub>	200 ±1%			Ω	

**Table 2.6 DC Characteristics (5) [USB2.0 Host/Function-Related Pins (Items for Both Full Speed and High Speed)\*1]**

Item	Symbol	min	typ	max	Unit	Test Conditions
DP pull-up resistor (when the function controller operation is selected)	R <sub>PU</sub>	0.900	—	1.575	kΩ	Idle
		1.425	—	3.090	kΩ	Transmission/ reception
DP/DM pull-down resistors (when the host function is selected)	R <sub>PD</sub>	14.25	—	24.80	kΩ	

Note 1. USB\_DP and USB\_DM pins

**Table 2.7 DC Characteristics (6) [USB2.0 Host/Function-Related Pins (Full Speed)\*1]**

Item	Symbol	min	typ	max	Unit	Measuring Condition
Input high level voltage	V <sub>FSIH</sub>	2.0	—	—	V	
Input low level voltage	V <sub>FSIL</sub>	—	—	0.8	V	
Differential input sensitivity	V <sub>FSDI</sub>	0.2	—	—	V	(USB_DP) – (USB_DM)
Differential common mode range	V <sub>FSCM</sub>	0.8	—	2.5	V	
Output high level voltage	V <sub>FSOH</sub>	2.8	—	3.6	V	I <sub>FSOH</sub> = -200 μA
Output low level voltage	V <sub>FSOL</sub>	0.0	—	0.3	V	I <sub>FSOL</sub> = 2 mA
Output signal crossover voltage	V <sub>FSCRS</sub>	1.3	—	2.0	V	CL = 50 pF (full-speed)

Note 1. USB\_DP and USB\_DM pins

**Table 2.8 DC Characteristics (7) [USB2.0 Host/Function-Related Pins (High Speed)\*1]**

Item	Symbol	min	typ	max	Unit	Test Conditions
Squelch detection threshold voltage (differential voltage)	V <sub>HSSQ</sub>	100	—	150	mV	
Common mode voltage range	V <sub>HSCM</sub>	-50	—	500	mV	
Idle state	V <sub>HSOI</sub>	-10.0	—	10.0	mV	
Output high level voltage	V <sub>HSOH</sub>	360	—	440	mV	
Output low level voltage	V <sub>HSOL</sub>	-10.0	—	10.0	mV	
Chirp J output voltage (differential)	V <sub>CHIRPJ</sub>	700	—	1100	mV	
Chirp K output voltage (differential)	V <sub>CHIRPK</sub>	-900	—	-500	mV	

Note 1. USB\_DP and USB\_DM pins



**Table 2.9 Permissible Output Currents**

Item		Symbol	min	typ	max	Unit
Permissible output low current (average value per pin)	Other than 5-V tolerant pins	$I_{OL1}$	—	—	2.0	mA
	5-V tolerant pins	$I_{OL2}$	—	—	3.0	mA
Permissible output low current (maximum value per pin)	Other than 5-V tolerant pins	$I_{OL1}$	—	—	4.0	mA
	5-V tolerant pins	$I_{OL2}$	—	—	6.0	mA
Permissible output low current (total)	Total of all output pins	$\Sigma I_{OL}$	—	—	80	mA
Permissible output high current (average value per pin)	All output pins	$I_{OH}$	—	—	-2.0	mA
Permissible output high current (maximum value per pin)	All output pins	$I_{OH}$	—	—	-4.0	mA
Permissible output high current (total)	Total of all output pins	$\Sigma I_{OH}$	—	—	-80	mA

[Usage Notes] All output current values shall be within the values in Table 2.9 to ensure the reliability of this LSI.

## 2.4 AC Characteristics

- Conditions: VDD = PLLVDD0 = PLLVDD1 = DVDD\_USB = 1.14 to 1.26 V,  
VCCQ33 = AVCC0 = AVCC1 = VREFH0 = VREFH1 = VDD33\_USB = 3.0 to 3.6 V  
VSS = PLLVSS0 = PLLVSS1 = AVSS0 = AVSS1 = VREFL0 = VREFL1 = VSS\_USB = 0 V,  
Tj = -40 to 125 °C

Note: The 176-pin HLQFP does not have pins AVCC1, AVSS1, VREFH1, and VREFL1.

**Table 2.10 Operating Frequency**

Item		Symbol	min	max	Unit	
Operating frequency	CPU clock (CPUCLK)	*1	150	600	MHz	
		*2	150	450		
		*3	150	300		
	System clock (ICLK)			150		
	Peripheral module clock (PCLKA)			150		
	Peripheral module clock (PCLKB)			75		
	Peripheral module clock (PCLKC)			150		
	Peripheral module clock (PCLKD)			75		
	Peripheral module clock (PCLKE)			18.75		75
	Peripheral module clock (PCLKF)			7.5		60
	Peripheral module clock (PCLKG)			7.5		60
	Peripheral module clock (PCLKH)			60		
	High-speed serial clock (SERICKL)			120		150
	ΔΣ interface clock output (DSCLK0, DSCLK1)			6.25		25
	External bus clock output (CKIO)			18.75		75
External clock output for Ethernet PHY (CLKOUT25M)			25	50		

Note 1. For R7S910007CBG, R7S910107CBG, R7S910013CBG, R7S910113CBG, R7S910017CBG, R7S910117CBG, R7S910018CBG, R7S910118CBG, R7S910027CBG, R7S910127CBG, R7S910028CBG, and R7S910128CBG only.

Note 2. For R7S910001CFP, R7S910101CFP, R7S910002CBG, R7S910102CBG, R7S910006CBG, R7S910106CBG, R7S910011CBG, R7S910111CBG, R7S910015CBG, R7S910115CBG, R7S910016CBG, R7S910116CBG, R7S910025CBG, R7S910125CBG, R7S910026CBG, and R7S910126CBG only.

Note 3. For R7S910035CBG, R7S910135CBG, R7S910036CBG, and R7S910136CBG only.

### 2.4.1 Clock Timing

**Table 2.11 CKIO Pin Output Timing**

Output load condition: C = 30 pF

Item	Symbol	min	typ	max	Unit	Test Conditions
CKIO pin output cycle time	$t_{CKcyc}$	13.3	—	53.4	ns	Figure 2.2
CKIO pin output high level pulse width	$t_{CKH}$	$t_{CKcyc}/2 - t_{CKr}$	—	—	ns	
CKIO pin output low level pulse width	$t_{CKL}$	$t_{CKcyc}/2 - t_{CKf}$	—	—	ns	
CKIO pin output rising time 1	$t_{CKr}$	—	—	5	ns	CKIO: High drive output setting*1
CKIO pin output falling time 1	$t_{CKf}$	—	—	5	ns	$V_{OH} = V_{CCQ33} - 0.5\text{ V}$ $V_{OL1} = 0.4\text{ V}$
CKIO pin output rising time 2	$t_{CKr}$	—	—	9	ns	CKIO: Normal output setting
CKIO pin output falling time 2	$t_{CKf}$	—	—	9	ns	$V_{OH} = V_{CCQ33} - 0.5\text{ V}$ $V_{OL1} = 0.4\text{ V}$
CKIO pin output rising time 3	$t_{CKr}$	—	—	2.5	ns	CKIO: High drive output setting*1
CKIO pin output falling time 3	$t_{CKf}$	—	—	2.5	ns	$V_{OH} = 2.0\text{ V}$ $V_{OL1} = 0.8\text{ V}$
CKIO pin output rising time 4	$t_{CKr}$	—	—	4.5	ns	CKIO: Normal output setting
CKIO pin output falling time 4	$t_{CKf}$	—	—	4.5	ns	$V_{OH} = 2.0\text{ V}$ $V_{OL1} = 0.8\text{ V}$

Note 1. When connecting SDRAM, be sure to set the B0 bit in the drive capacity control register (DSCR) to 1 to be a high drive output.

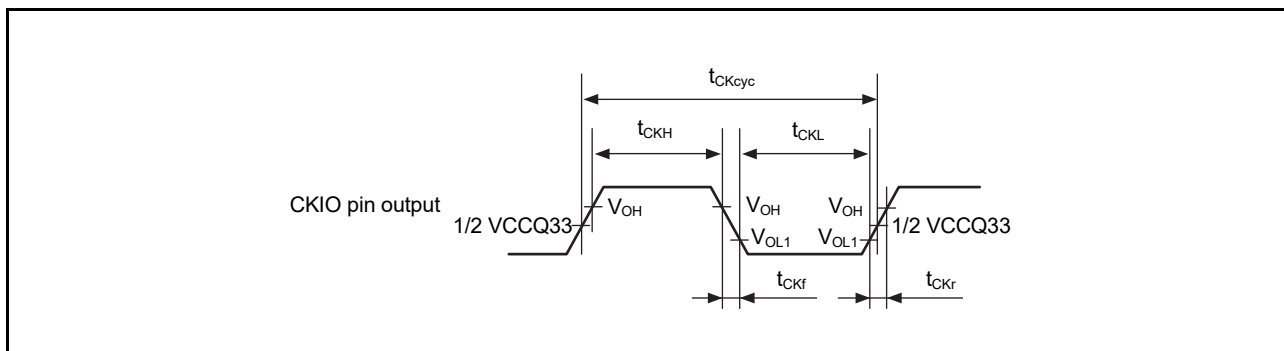
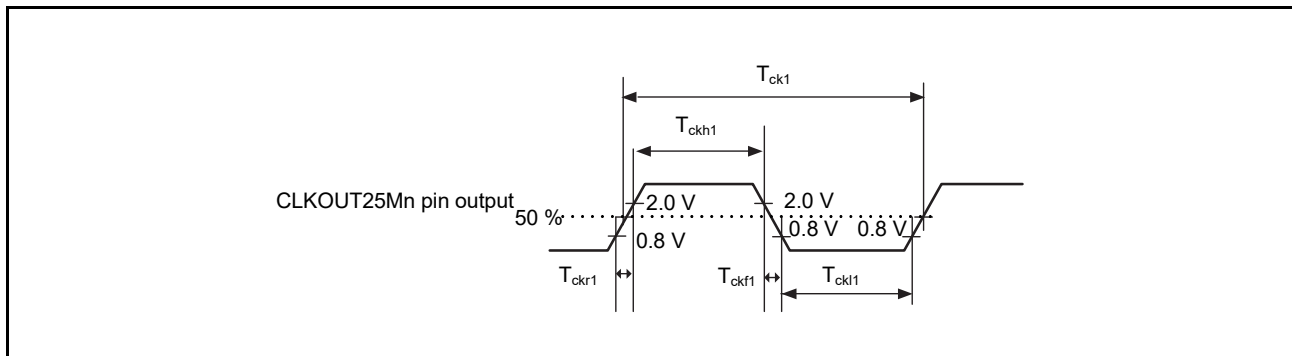

**Figure 2.2 CKIO Pin Output Timing**

**Table 2.12 CLKOUT25Mn Timing**

Output load conditions:  $V_{OH} = 2.0\text{ V}$ ,  $V_{OL1} = 0.8\text{ V}$ ,  $C = 25\text{ pF}$  (RMII)  
 $V_{OH} = V_{CCQ33} - 0.5\text{ V}$ ,  $V_{OL1} = 0.4\text{ V}$ ,  $C = 30\text{ pF}$  (MII)

Item	Symbol	min	max	Unit	Test Conditions	
CLKOUT25Mn (RMII)	CLKOUT25Mn cycle time	$T_{ck1}$	20	—	ns	Figure 2.3
	CLKOUT25Mn frequency	Typ. 50 MHz	—	50 + 50 ppm	MHz	
	CLKOUT25Mn duty	—	35	65	%	
	CLKOUT25Mn output low pulse width 1	$T_{ckl1}$	$T_{ck1}/2 - T_{ckf1}$	$T_{ck1}/2 + T_{ckf1}$	ns	
	CLKOUT25Mn output high pulse width 1	$T_{ckh1}$	$T_{ck1}/2 - T_{ckr1}$	$T_{ck1}/2 + T_{ckr1}$	ns	
	CLKOUT25Mn rising/falling time 1	$T_{ckr1}/ckf1$	0.5	4	ns	
CLKOUT25Mn (MII)	CLKOUT25Mn cycle time	$T_{ck2}$	40	—	ns	Figure 2.4
	CLKOUT25Mn frequency	Typ. 25 MHz	—	25 + 50 ppm	MHz	
	CLKOUT25Mn duty	—	35	65	%	
	CLKOUT25Mn output low pulse width 2	$T_{ckl2}$	$T_{ck2}/2 - T_{ckf2}$	$T_{ck2}/2 + T_{ckf2}$	ns	
	CLKOUT25Mn output high pulse width 2	$T_{ckh2}$	$T_{ck2}/2 - T_{ckr2}$	$T_{ck2}/2 + T_{ckr2}$	ns	
	CLKOUT25Mn rising/falling time 2	$T_{ckr2}/ckf2$	0.5	9	ns	



**Figure 2.3 CLKOUT25Mn Pin Output Timing 1**

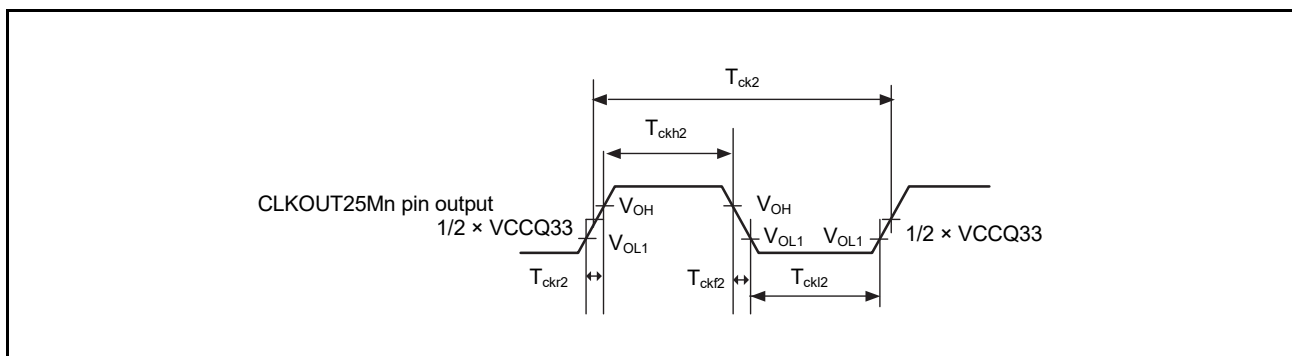
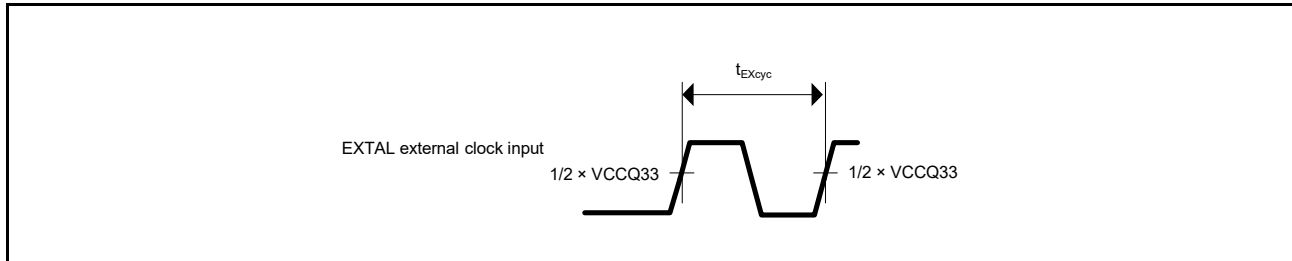

**Figure 2.4 CLKOUT25Mn Pin Output Timing 2**

**Table 2.13 EXTAL Clock Timing**

Item	Symbol	min	typ	max	Unit
EXTAL external clock input cycle time	$t_{EXcyc}$		40.00 ± 50 ppm		ns
				25.00 ± 25ppm*1	MHz

Note 1. When EtherCAT is in use.

**Figure 2.5 EXTAL External Clock Input Timing****Table 2.14 XTAL Clock Timing**

Item	Symbol	min	typ	max	Unit
XTAL clock oscillator output cycle*1	$t_{XTALcyc}$		40.00 ± 50 ppm*2		ns

Note 1. When using the XTAL clock, ask the oscillator manufacturer to evaluate oscillation of the oscillator. For the oscillation stabilization time, see the evaluation result provided by the oscillator manufacturer.

Note 2. When using the EtherCAT, make sure that the clock timing satisfies 25.00 MHz ± 25 ppm.

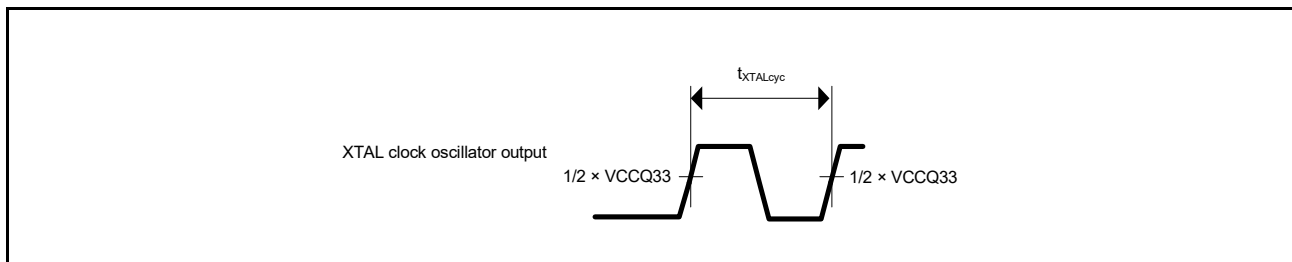
**Figure 2.6 XTAL Clock Oscillator Output Timing****Table 2.15 LOCO Clock Timing**

Item	Symbol	min	typ	max	Unit	Test Conditions
LOCO clock cycle time	$t_{Lcyc}$	4.62	4.17	3.79	μs	
LOCO clock oscillation frequency	$f_{LOCO}$	216	240	264	kHz	
LOCO clock oscillation stabilization wait time	$t_{LOCOWT}$	—	—	40	μs	Figure 2.7

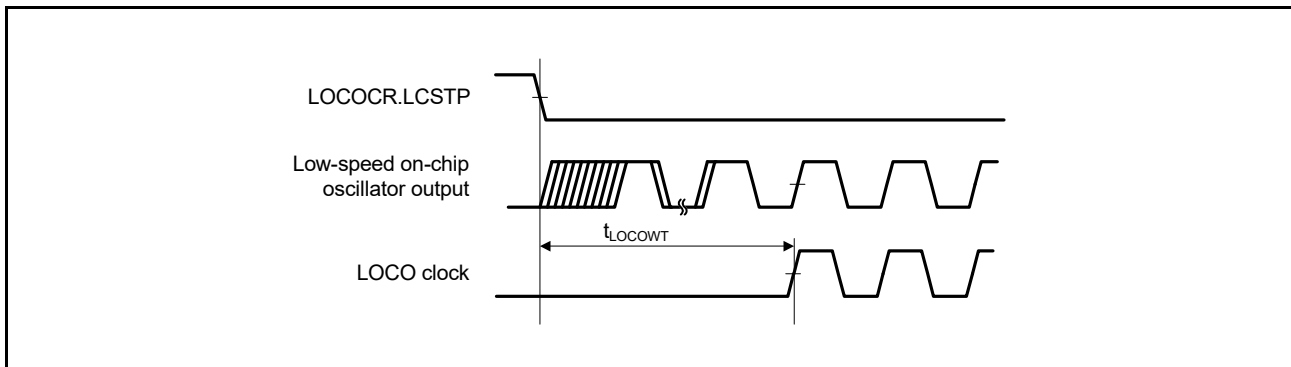

Figure 2.7 LOCO Clock Oscillation Start Timing

### 2.4.2 Reset Timing and Interrupt Timing

**Table 2.16 Reset Timing and Interrupt Timing**

Item		Symbol	Min*1	typ	max	Unit	Test Conditions
RES# pulse width	At power on	$T_{dlyreset}$	10	—	—	ms	Figure 2.8
	Other than above	$T_{dlyreset2}$	1	—	—	ms	
RES# rising time		$T_{risereset}$	—	—	150	$\mu$ s	
TRST# pulse width	At power on	$T_{dlyreset}$	10	—	—	ms	
	Other than above	$T_{dlyreset2}$	1	—	—	ms	
TRST# rising time		$T_{risereset}$	—	—	150	$\mu$ s	
NMI pulse width		$t_{NMIW}$	$t_{cyc} \times 2$	—	—	ns	Figure 2.9
IRQ pulse width		$t_{IRQW}$	$t_{cyc} \times 2$	—	—	ns	Figure 2.10
ETH_INT pulse width		$t_{EINTW}$	$t_{cyc} \times 2$	—	—	ns	Figure 2.11

Note 1.  $t_{cyc}$ : ICLK cycle

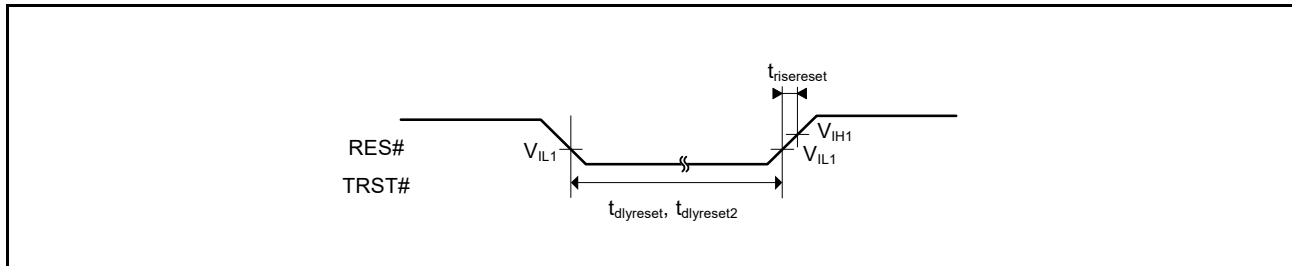

**Figure 2.8 Reset Input Timing**

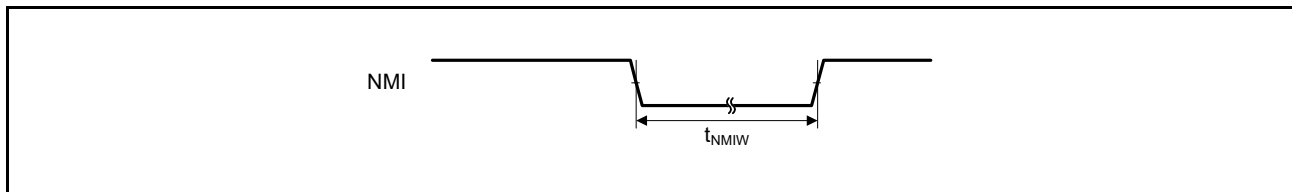

**Figure 2.9 NMI Interrupt Input Timing**

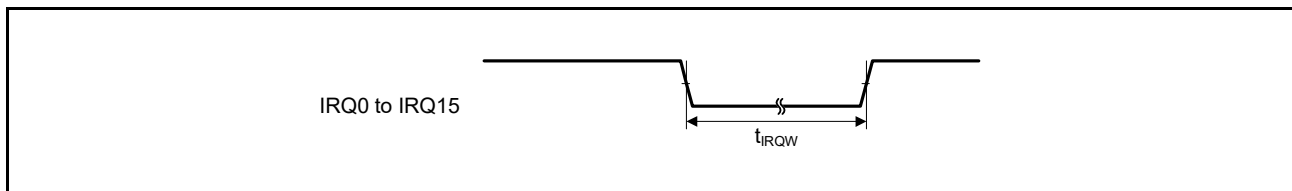

**Figure 2.10 IRQ Interrupt Input Timing**

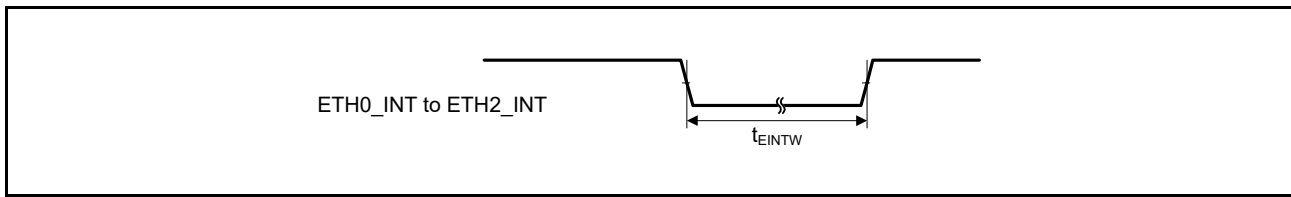

Figure 2.11 ETH\_INT Interrupt Input Timing



## 2.4.3 Bus Timing

**Table 2.17 Bus Timing (1 / 2)**Output load conditions:  $V_{OH} = V_{CCQ33} \times 0.5$ ,  $V_{OL1} = V_{CCQ33} \times 0.5$ ,  $C = 30$  pF

Item	Symbol	CKIO = $1/t_{CKcyc}^{*1}$		Unit	Reference Figure	
		Min.	Max.			
Address delay time 1	SDRAM*3	$t_{AD1}$	2	10	ns	Figure 2.12 to Figure 2.36
	Other than the above		0	10	ns	
Address delay time 2		$t_{AD2}$	$1/2t_{CKcyc}$	$1/2t_{CKcyc} + 10$	ns	Figure 2.19
Address setup time		$t_{AS}$	0	—	ns	Figure 2.12 to Figure 2.15, Figure 2.19
Chip enable setup time		$t_{cs}$	0	—	ns	Figure 2.12 to Figure 2.15, Figure 2.19
Address hold time		$t_{AH}$	0	—	ns	Figure 2.12 to Figure 2.15
BS# delay time		$t_{BSD}$	—	10	ns	Figure 2.12 to Figure 2.33
CS# delay time 1	SDRAM*3	$t_{CSD1}$	2	10	ns	Figure 2.12 to Figure 2.36
	Other than the above		0	10	ns	
Read/write delay time 1	SDRAM*3	$t_{RWD1}$	2	10	ns	Figure 2.12 to Figure 2.36
	Other than the above		0	10	ns	
Read strobe delay time		$t_{RSD}$	$1/2t_{CKcyc}$	$1/2t_{CKcyc} + 10$	ns	Figure 2.12 to Figure 2.19
Read data setup time 1*4	High-drive output	$t_{RDS1}$	$1/2t_{CKcyc} + 4$	—	ns	Figure 2.12 to Figure 2.18
	Normal output		$1/2t_{CKcyc} + 7$	—	ns	
Read data setup time 2*4	High-drive output	$t_{RDS2}$	6.6	—	ns	Figure 2.20 to Figure 2.23, Figure 2.28 to Figure 2.30
	Normal output		10	—	ns	
Read data setup time 3*4	High-drive output	$t_{RDS3}$	$1/2t_{CKcyc} + 4$	—	ns	Figure 2.19
	Normal output		$1/2t_{CKcyc} + 7$	—	ns	
Read data hold time 1		$t_{RDH1}$	0	—	ns	Figure 2.12 to Figure 2.18
Read data hold time 2		$t_{RDH2}$	2	—	ns	Figure 2.20 to Figure 2.23, Figure 2.28 to Figure 2.30
Read data hold time 3		$t_{RDH3}$	0	—	ns	Figure 2.19
Write enable delay time 1		$t_{WED1}$	$1/2t_{CKcyc}$	$1/2t_{CKcyc} + 10$	ns	Figure 2.12 to Figure 2.17
Write enable delay time 2		$t_{WED2}$	—	10	ns	Figure 2.18
Write data delay time 1		$t_{WDD1}$	—	10	ns	Figure 2.12 to Figure 2.18
Write data delay time 2		$t_{WDD2}$	—	10	ns	Figure 2.24 to Figure 2.27, Figure 2.31 to Figure 2.33
Write data hold time 1		$t_{WDH1}$	1	—	ns	Figure 2.12 to Figure 2.18

**Table 2.17 Bus Timing (2 / 2)**Output load conditions:  $V_{OH} = V_{CCQ33} \times 0.5$ ,  $V_{OL1} = V_{CCQ33} \times 0.5$ ,  $C = 30$  pF

Item	Symbol	CKIO = $1/t_{CKcyc}^{*1}$		Unit	Reference Figure
		Min.	Max.		
Write data hold time 2	$t_{WDH2}$	2	—	ns	Figure 2.24 to Figure 2.27, Figure 2.31 to Figure 2.33
Write data hold time 4	$t_{WDH4}$	0	—	ns	Figure 2.12 to Figure 2.16
WAIT# setup time*4	High-drive output	$t_{WTS}$	$1/2t_{CKcyc} + 4.5$	ns	Figure 2.13 to Figure 2.19
	Normal output		$1/2t_{CKcyc} + 8$	ns	
WAIT# hold time	$t_{WTH}$	$1/2t_{CKcyc} + 3.5$	—	ns	Figure 2.13 to Figure 2.19
RAS# delay time 1	$t_{RASD1}$	2	10	ns	Figure 2.20 to Figure 2.36
CAS# delay time 1	$t_{CASD1}$	2	10	ns	Figure 2.20 to Figure 2.36
DQM delay time 1	$t_{DQMD1}$	2	10	ns	Figure 2.20 to Figure 2.33
CKE delay time 1	$t_{CKED1}$	2	10	ns	Figure 2.35
AH# delay time	$t_{AHD}$	$1/2t_{CKcyc}$	$1/2t_{CKcyc} + 10$	ns	Figure 2.16
Multiplex address delay time	$t_{MAD}$	—	10	ns	Figure 2.16
Multiplex address hold time	$t_{MAH}$	1	—	ns	Figure 2.16
Address setup time to AH#	$t_{AVVH}$	$1/2t_{CKcyc} - 2$	—	ns	Figure 2.16
DACK/TEND delay time	$t_{DACD}$	See DMAC timing	See DMAC timing	ns	Figure 2.12 to Figure 2.33

Note 1. Take the number of cycles of waiting that suits the system configuration into consideration with regard to the fmax value for CKIO (the external bus clock). When CKIO is running at 50 MHz or a higher frequency, set the B0 bit of the driving ability control register (DSCR) to 1 to select high-drive output. When CKIO is running at less than 50 MHz, normal output of CKIO can be used (DSCR.B0 bit = 0).

Note 2. Notation of  $1/2t_{CKcyc}$  in the delay time, setup time, and hold time shows 1/2 cycles from the clock rising edge, that is, the reference of clock falling.

Note 3. These are values when SDRAM (TYPE[2:0] bits = 100b) is selected in the CSn space bus control register (CSnBCR) and high-drive output (B0 bit = 1) is selected in the driving ability control register (DSCR) for CKIO.

Note 4. These are values when high-drive output (B0 bit = 1) and normal output (B0 bit = 0) are respectively selected in the driving ability control register (DSCR) for CKIO.

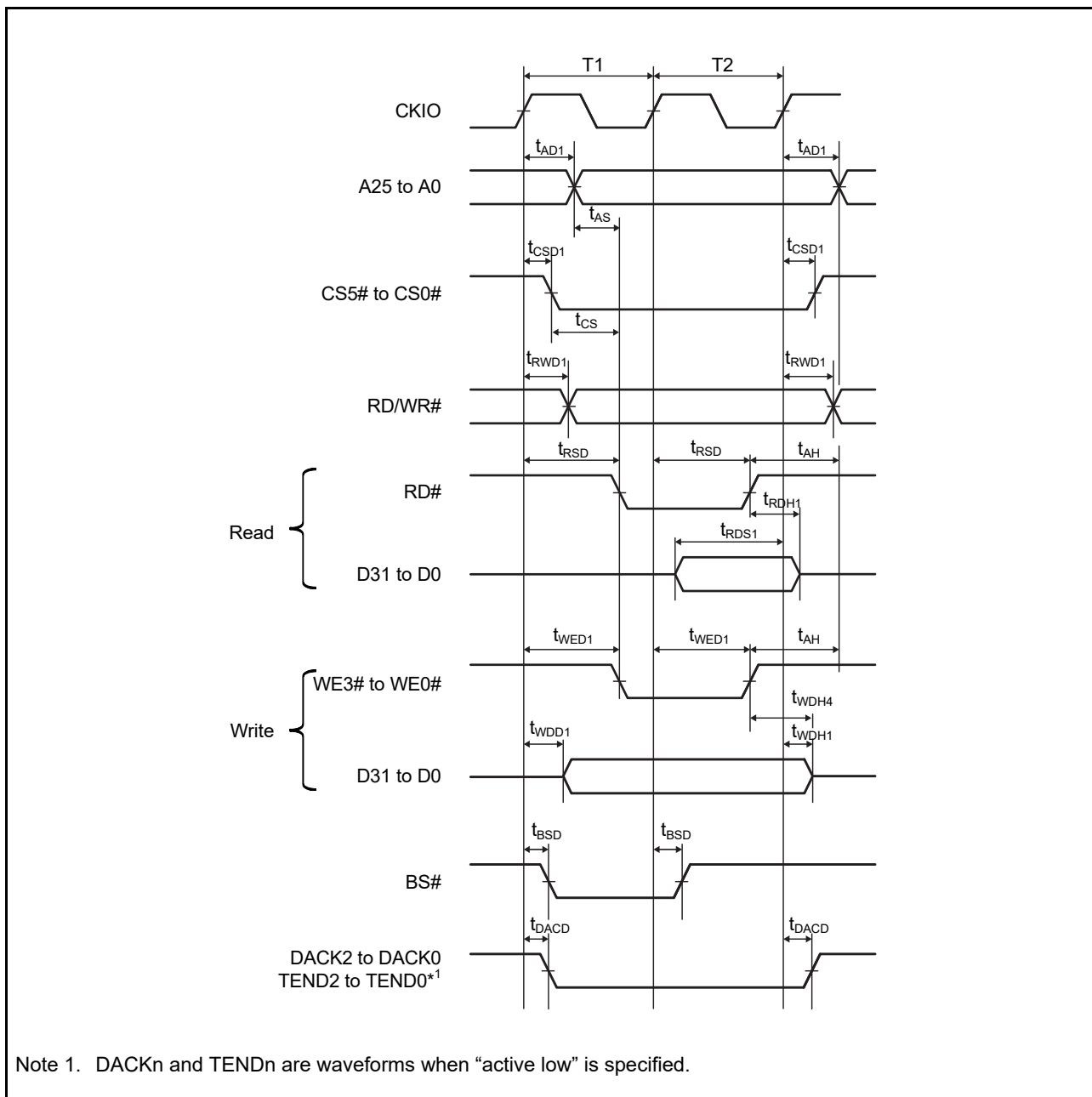

Figure 2.12 SRAM Interface Basic Bus Cycle (No Wait)

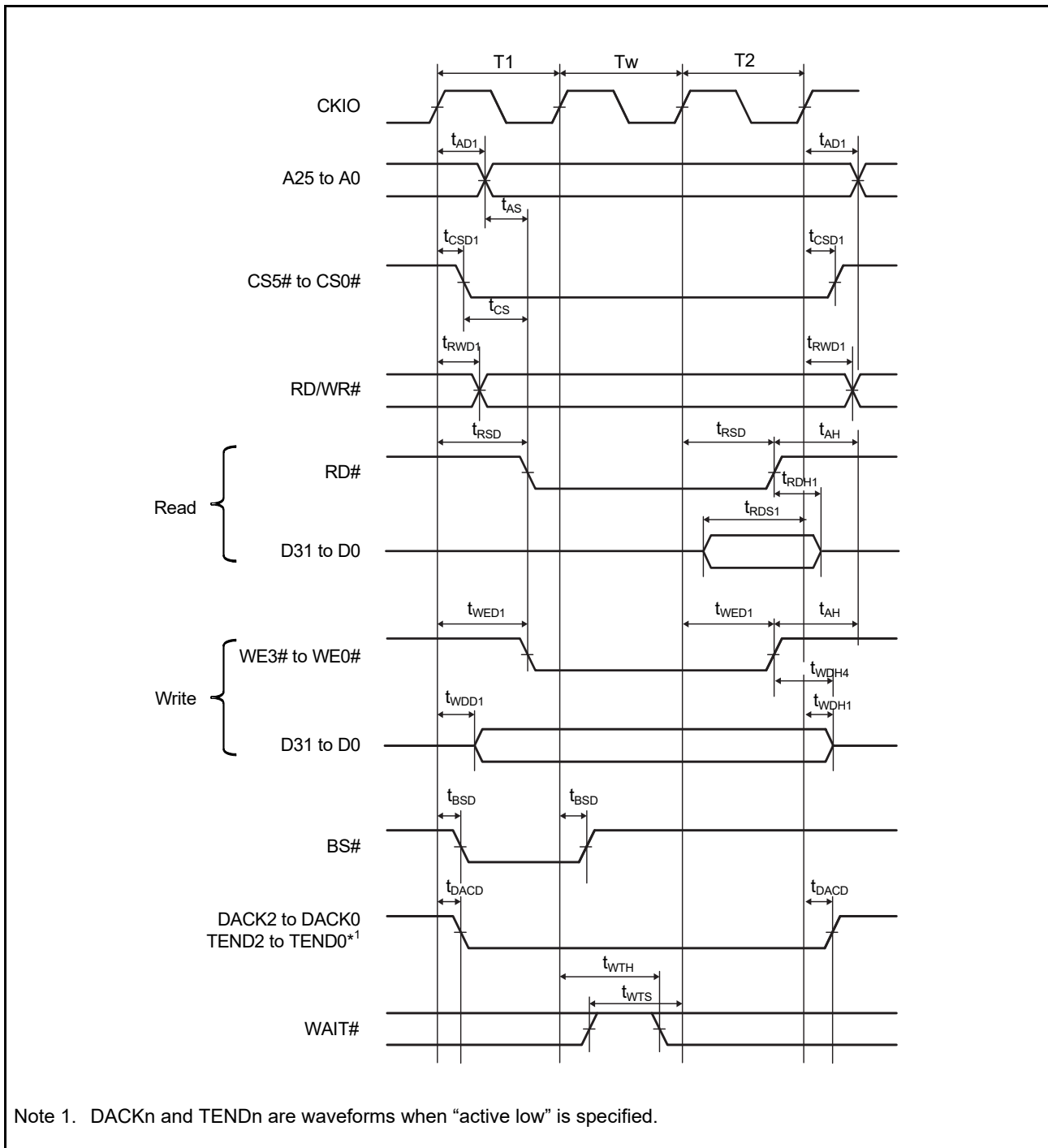

Figure 2.13 SRAM Interface Basic Bus Cycle (Software Wait 1)

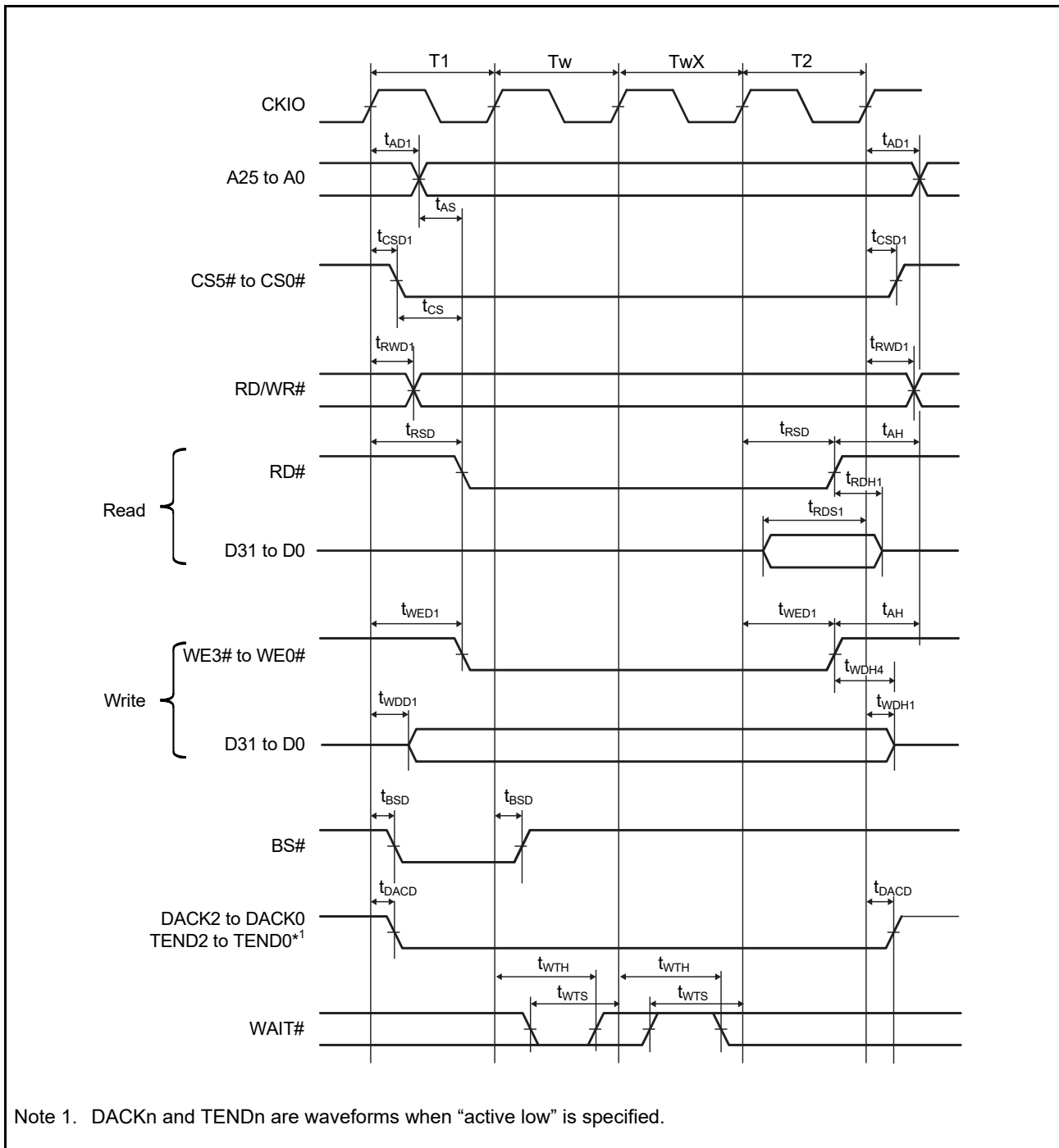

Figure 2.14 SRAM Interface Basic Bus Cycle (Software Wait 1, External Wait 1 Inserted)

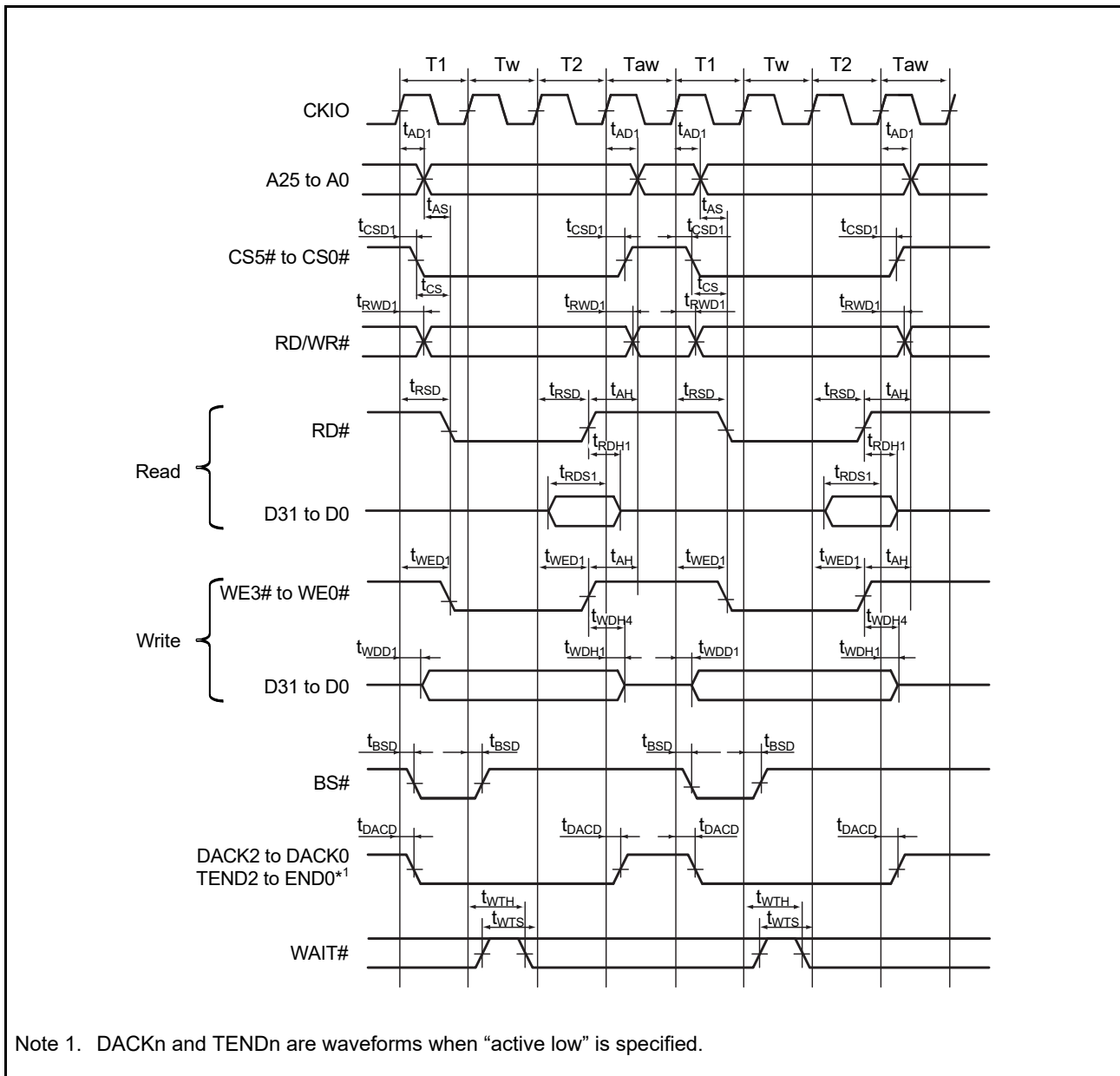
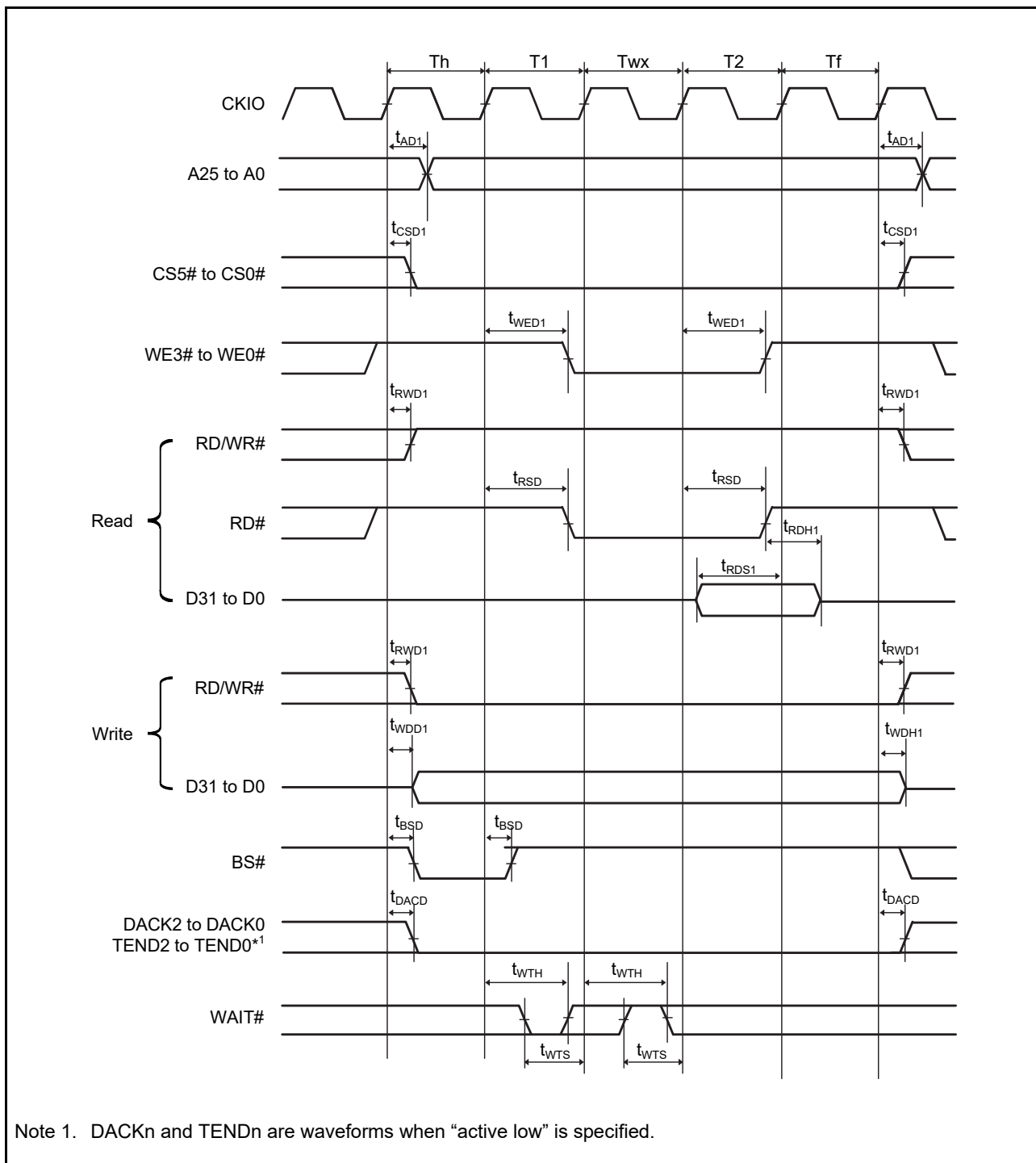

Figure 2.15 SRAM Interface Basic Bus Cycle (Software Wait 1, External wait Enabled (WM Bit = 0), No Idle Cycle)





**Figure 2.17 SRAM Bus Cycle with Byte Selection (SW = 1 Cycle, HW = 1 Cycle, Asynchronous External Wait 1 Inserted, BAS = 0 (Write Cycle UB/LB Control))**



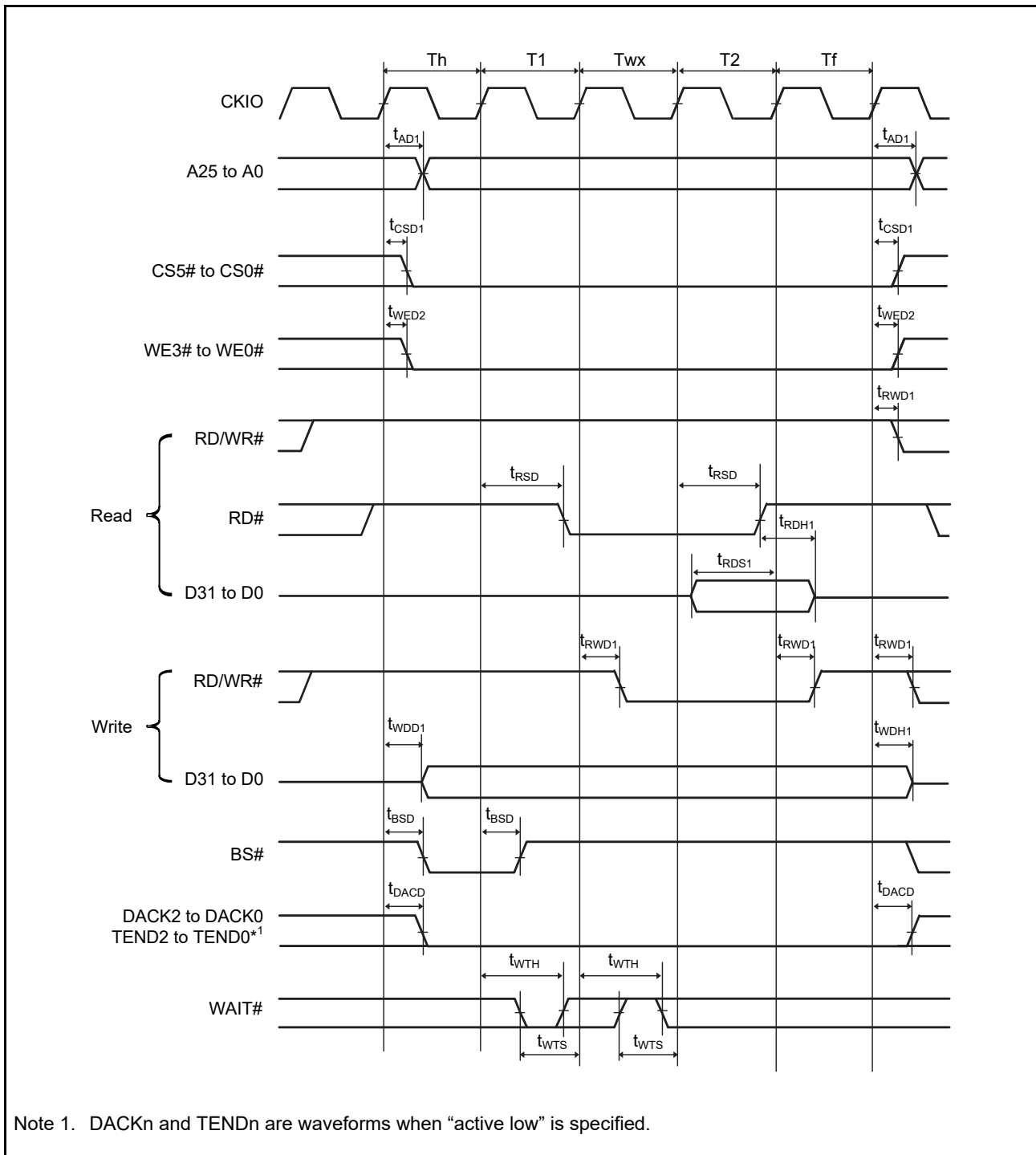

**Figure 2.18 SRAM Bus Cycle with Byte Selection (SW = 1 Cycle, HW = 1 Cycle, Asynchronous External Wait 1 Inserted, BAS = 1 (Write Cycle WE Control))**

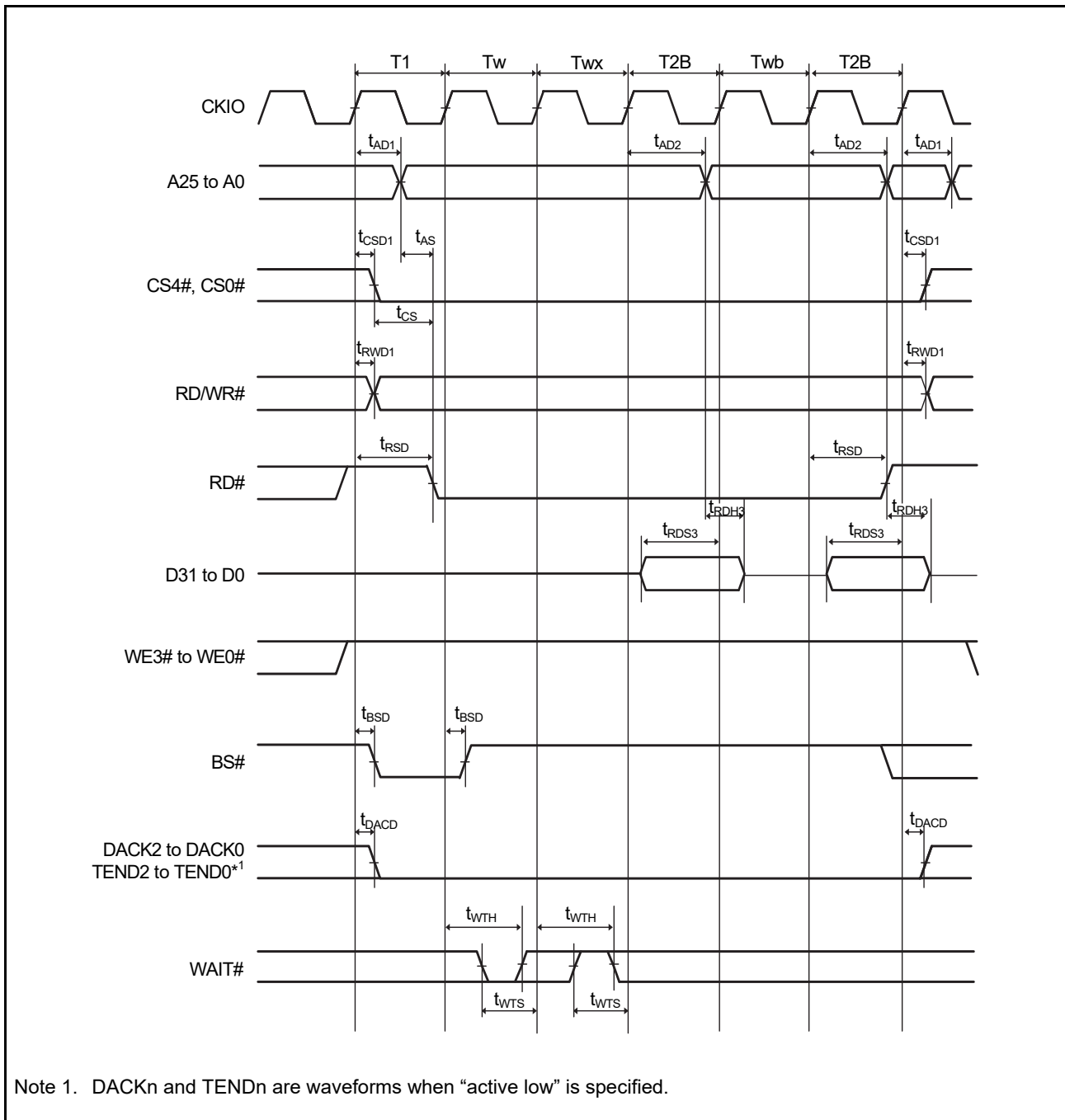
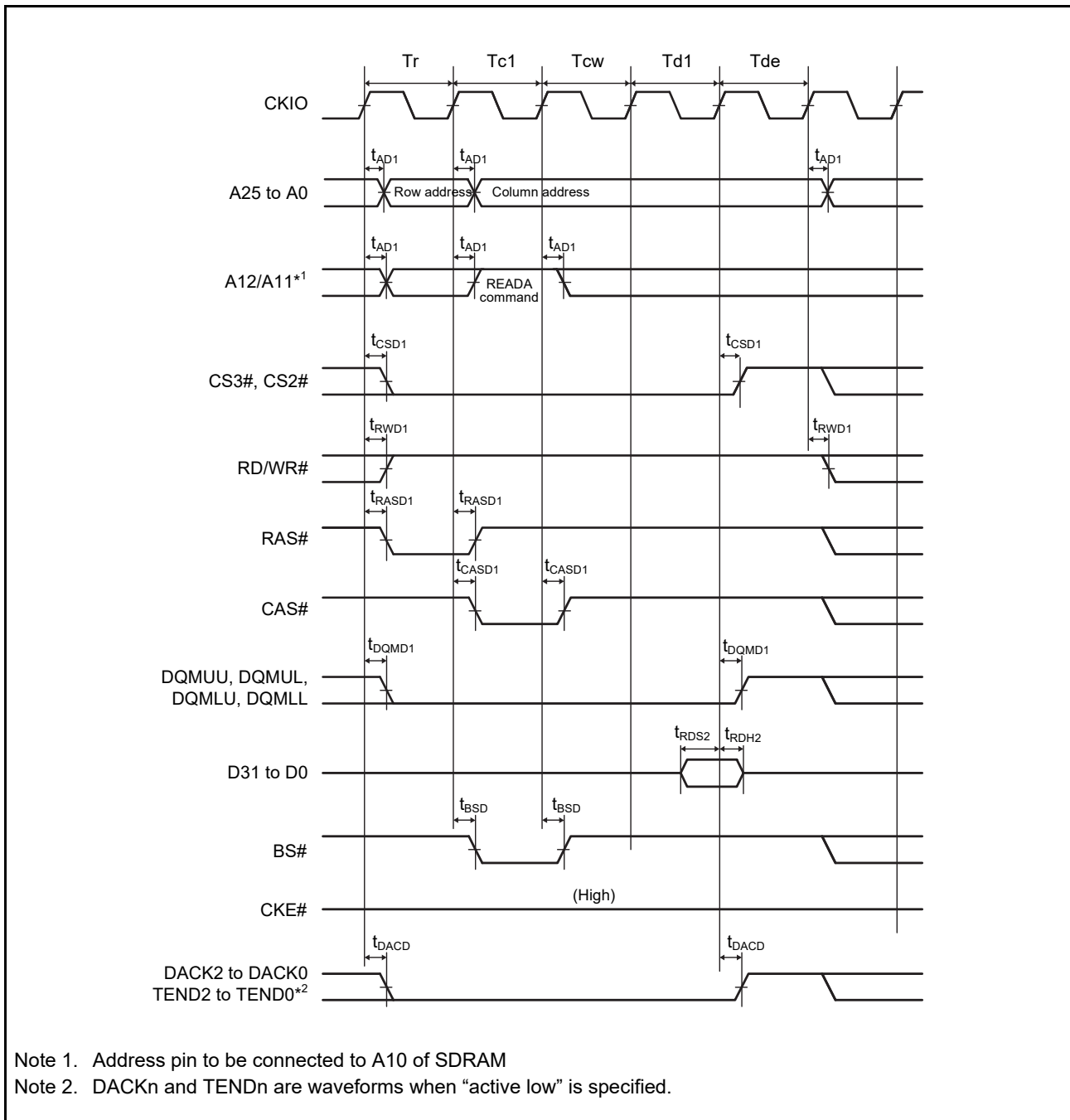
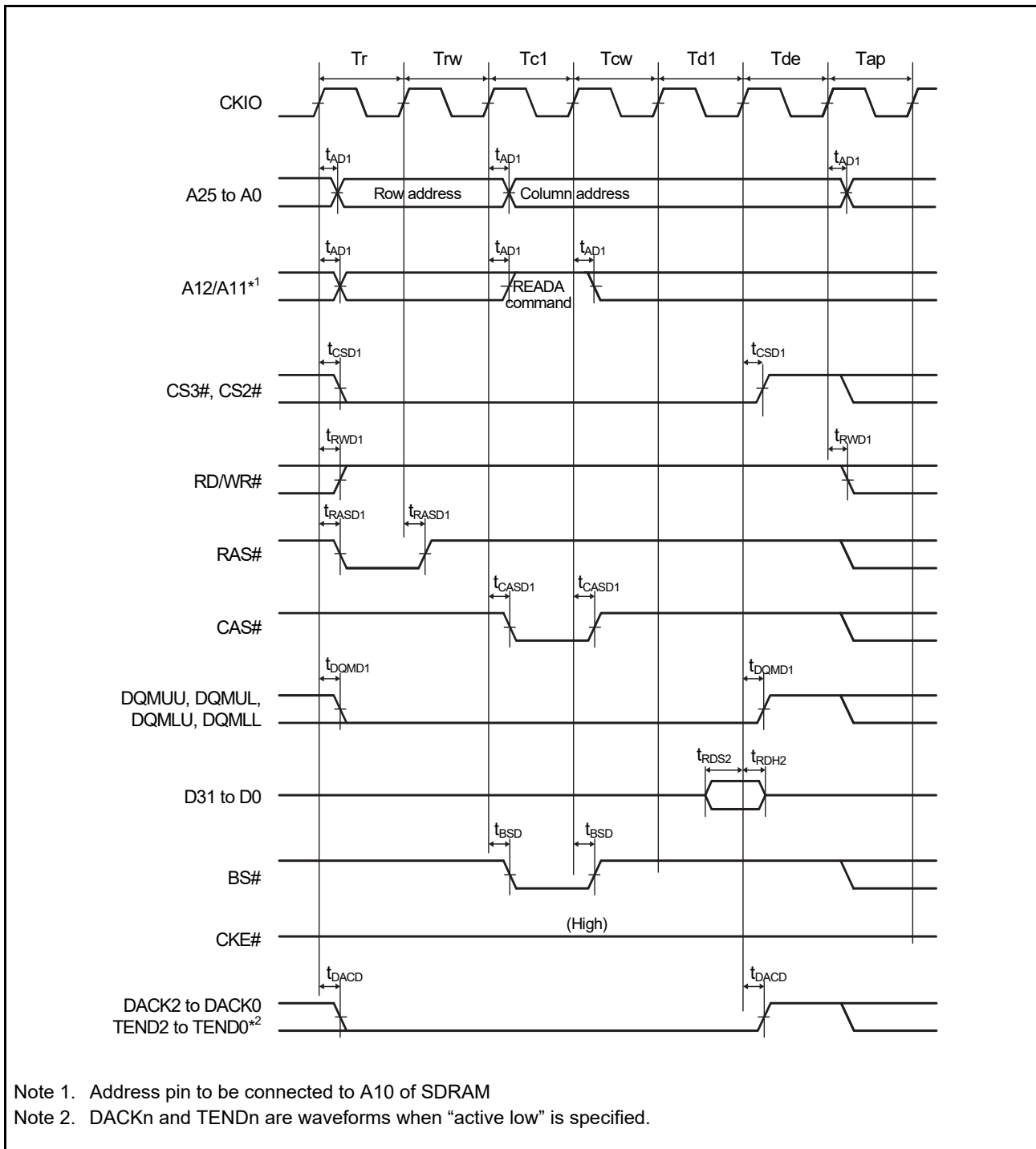

Figure 2.19 Burst ROM Read Cycle (Software Wait 1, Asynchronous External Wait 1 Inserted, Burst Wait 1, 2)



**Figure 2.20 Synchronous DRAM Single-Read Bus Cycle (with Auto Precharge, CAS Latency 2, WTRCD = 0 Cycles, WTRP = 0 Cycles)**



**Figure 2.21 Synchronous DRAM Single-Read Bus Cycle (with Auto Precharge, CAS Latency 2, WTRCD = 1 Cycle, WTRP = 1 Cycle)**

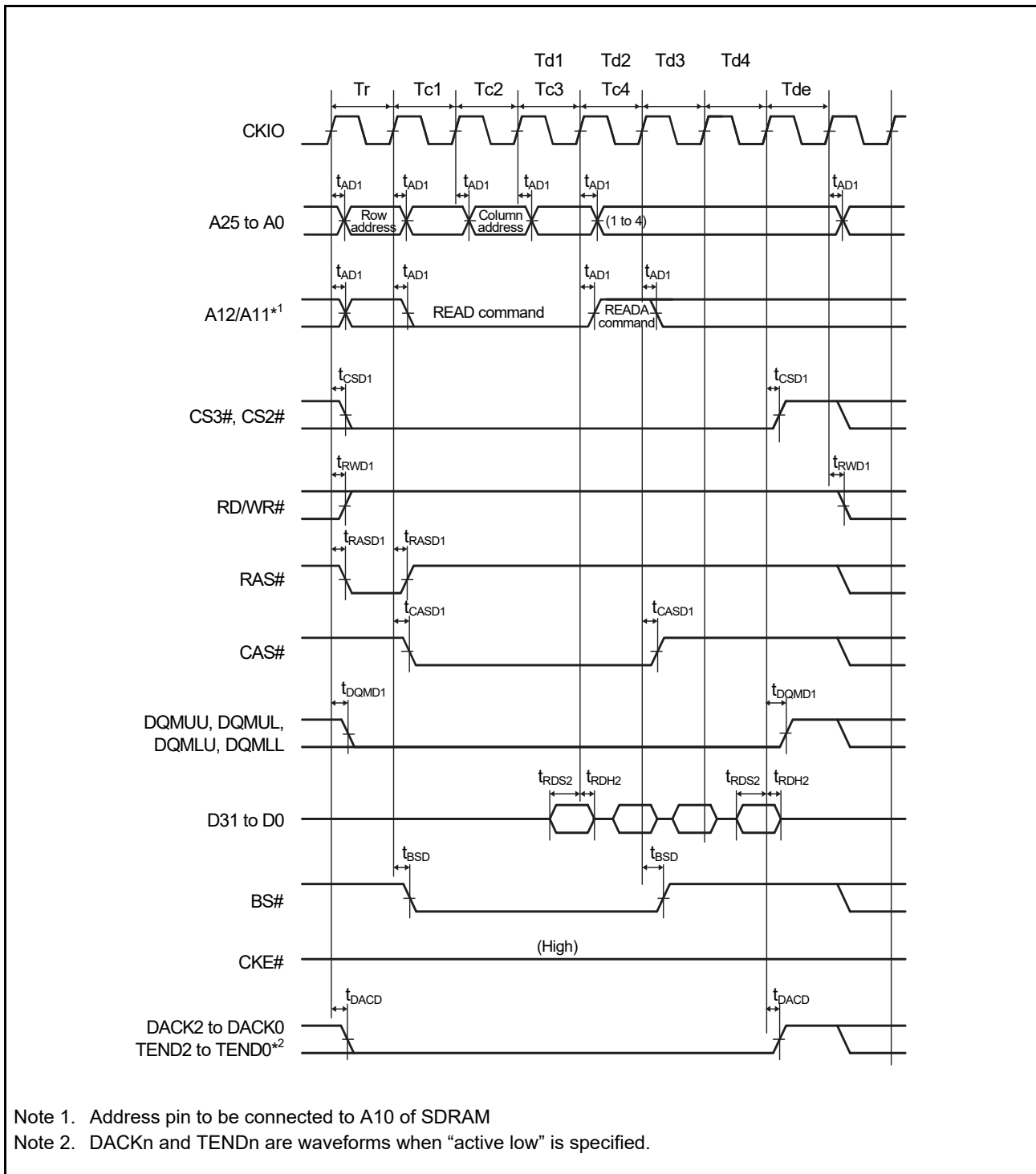

**Figure 2.22 Synchronous DRAM Burst-Read Bus Cycle (Read for 4 Cycles) (with Auto Precharge, CAS Latency 2, WTRCD = 0 Cycles, WTRP = 1 Cycle)**

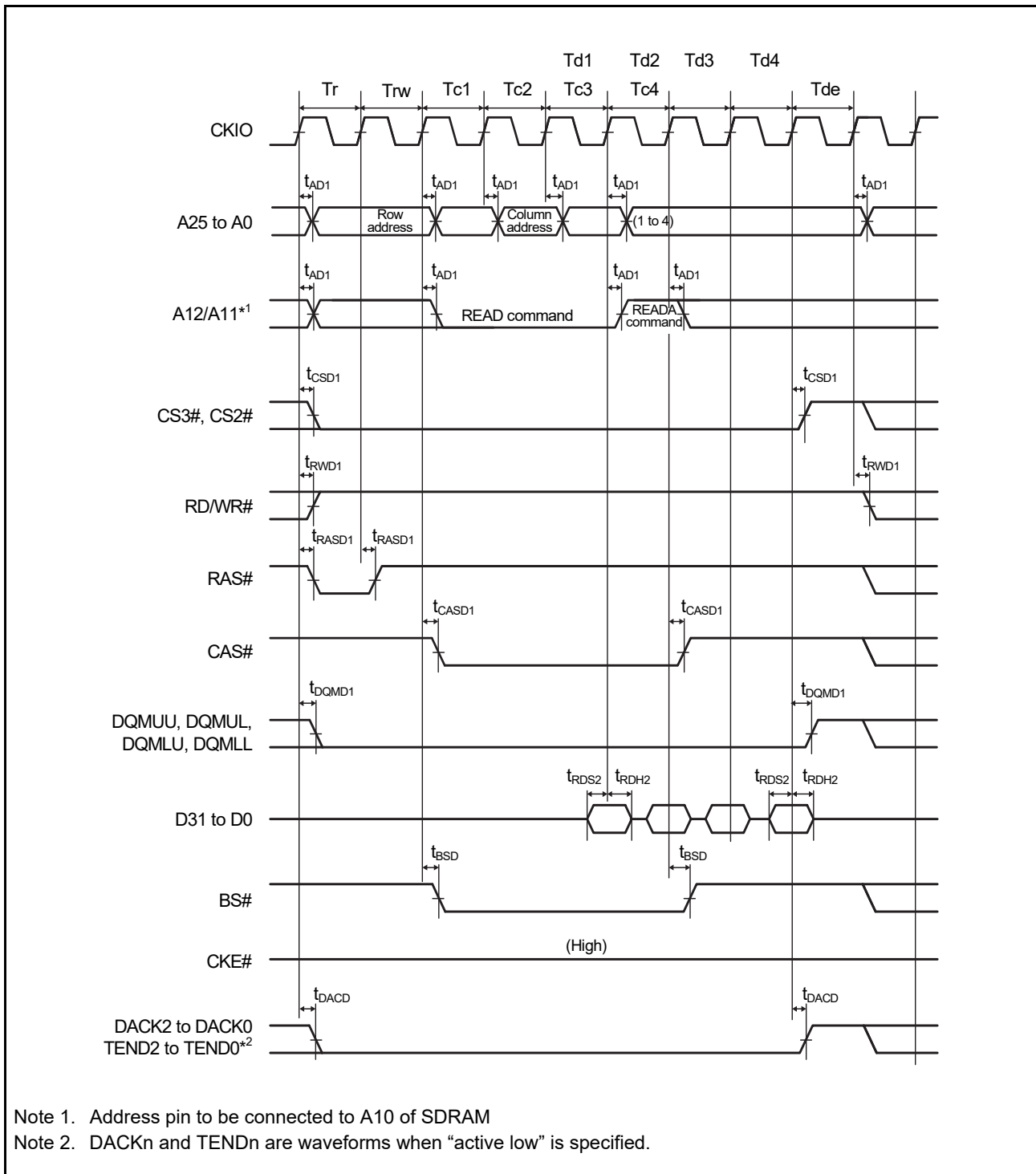

**Figure 2.23 Synchronous DRAM Burst-Read Bus Cycle (Read for 4 Cycles) (with Auto Precharge, CAS Latency 2, WTRCD = 1 Cycle, WTRP = 0 Cycles)**

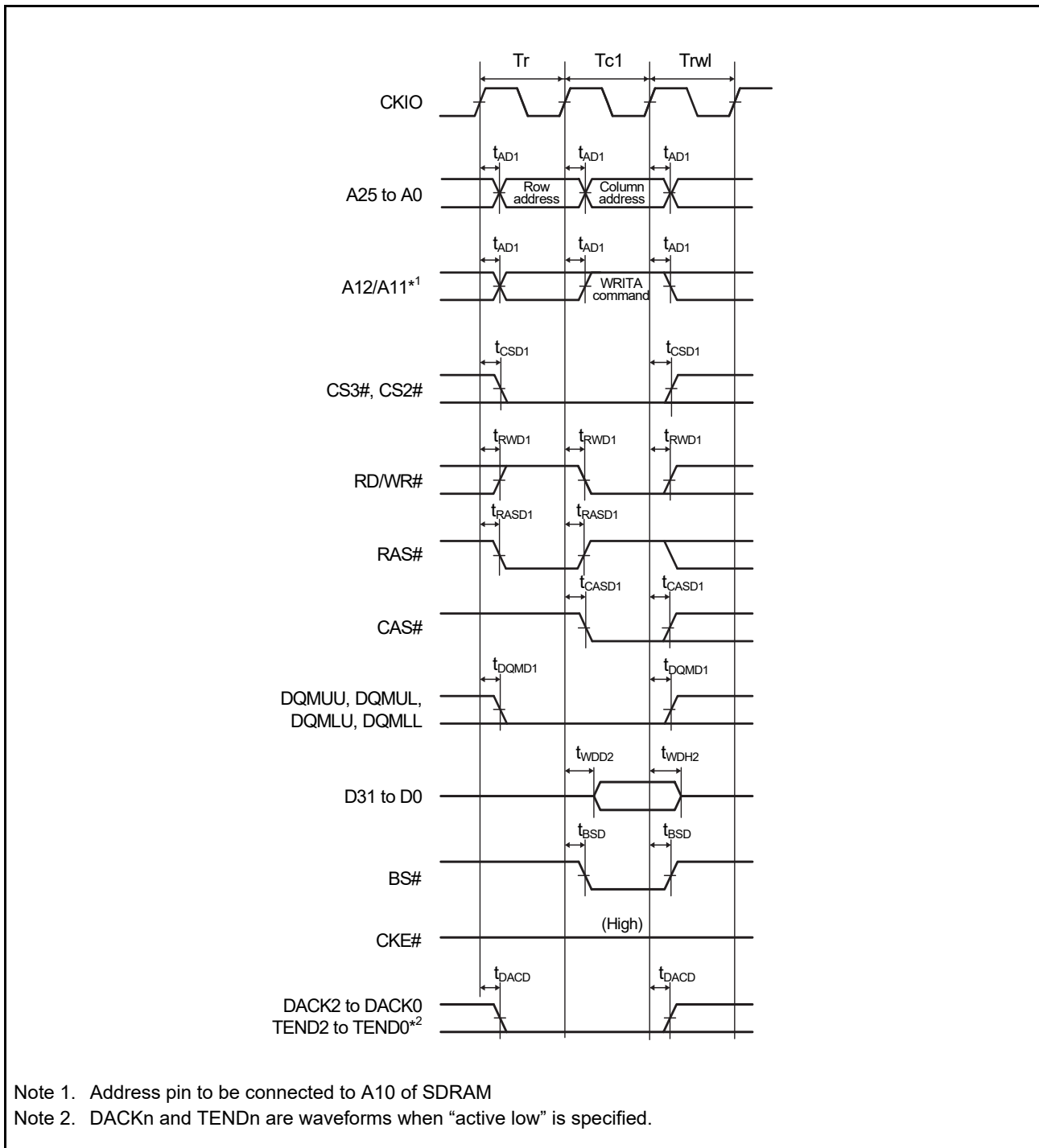
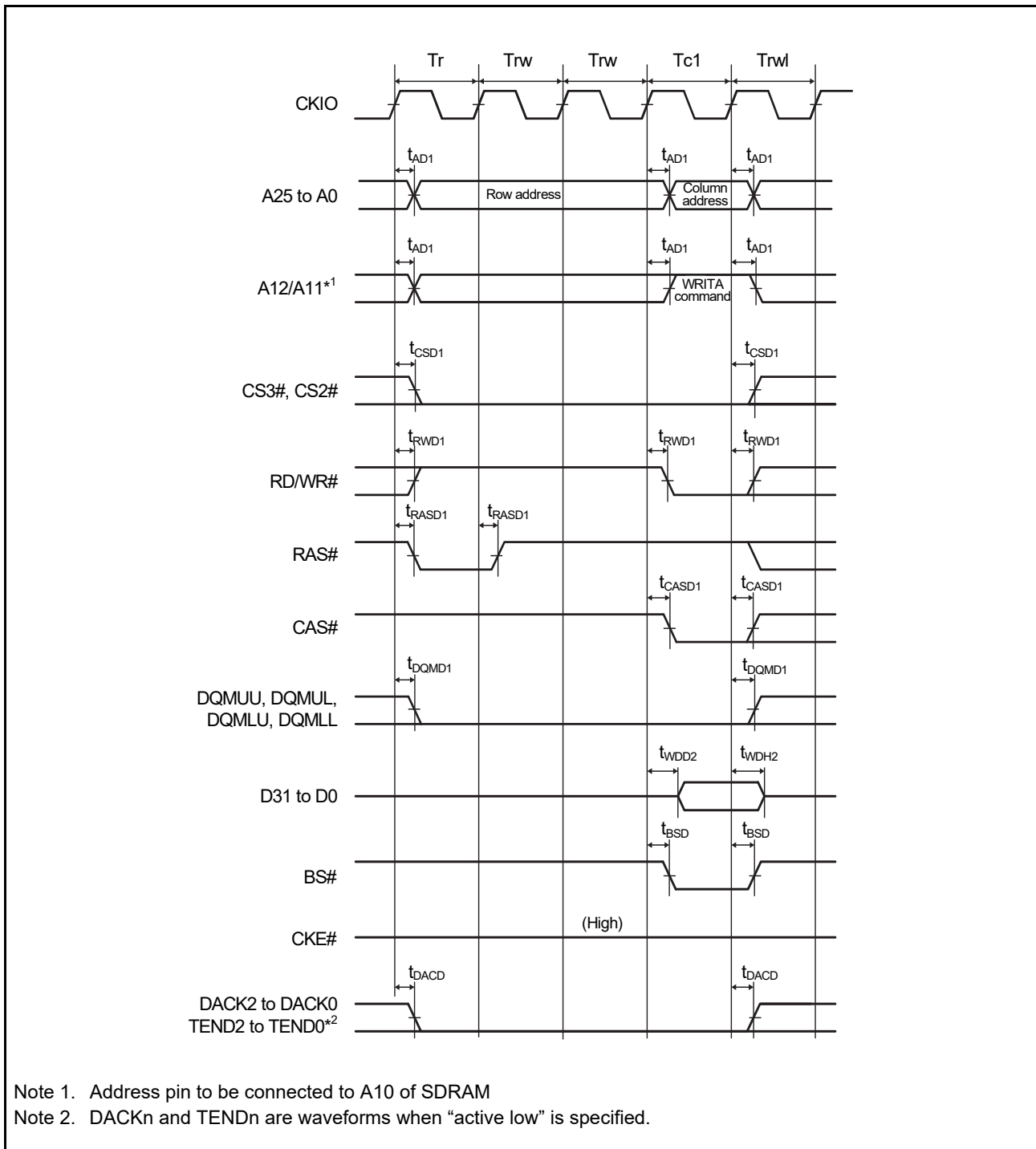
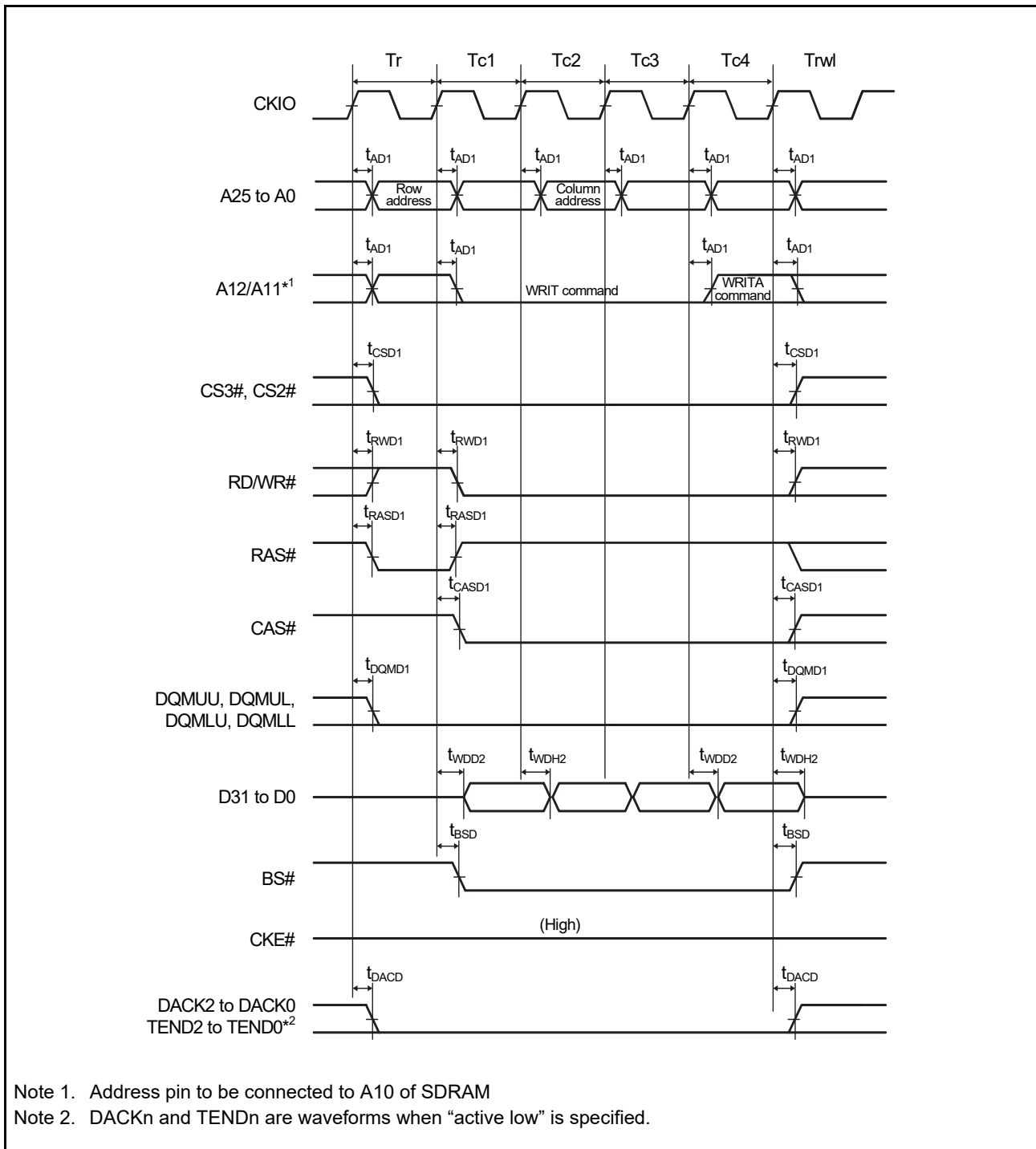

Figure 2.24 Synchronous DRAM Single-Write Bus Cycle (with Auto Precharge, TRWL = 1 Cycle)

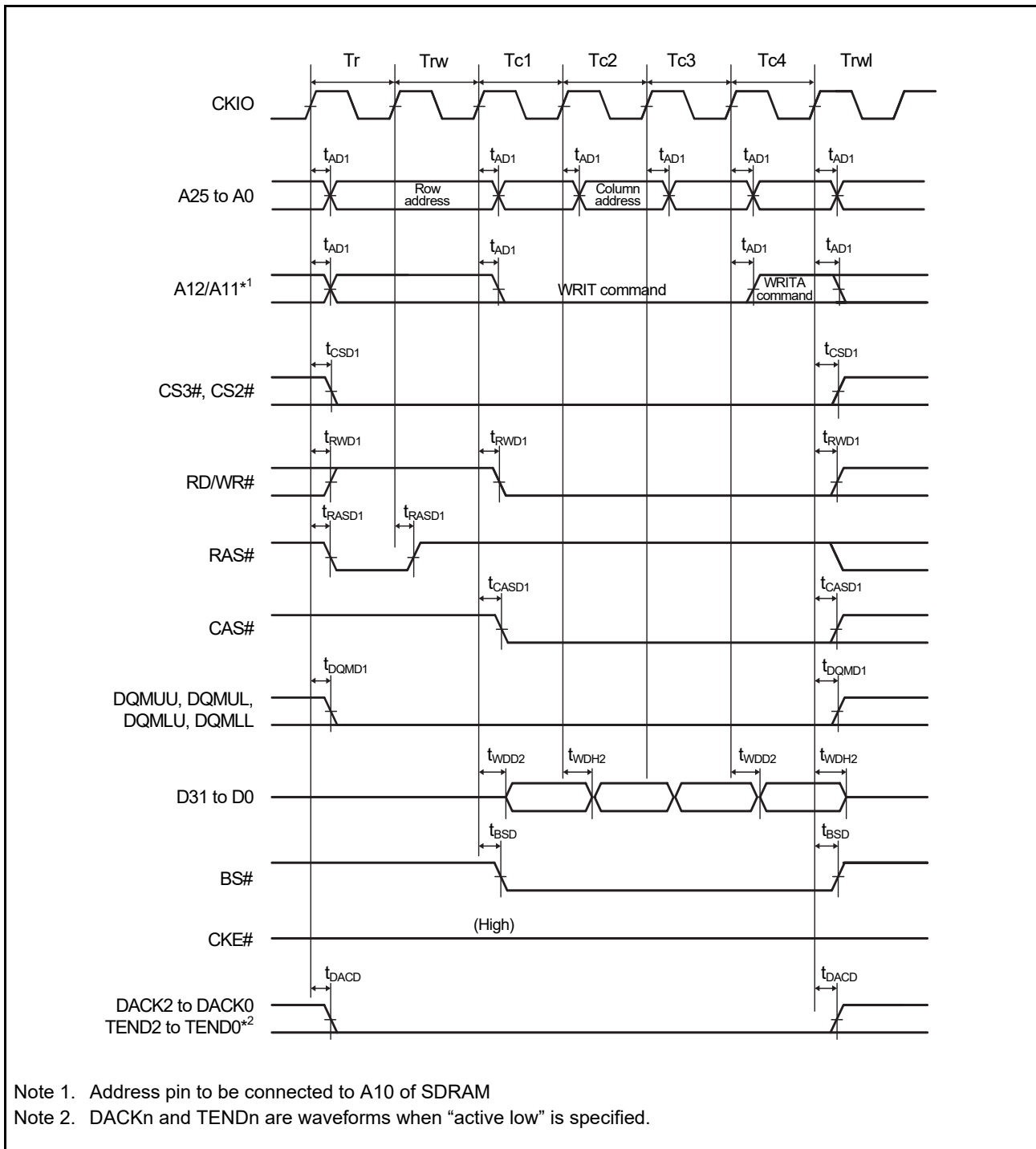

**Figure 2.25 Synchronous DRAM Single-Write Bus Cycle (with Auto Precharge, WTRCD = 2 Cycles, TRWL = 1 Cycle)**

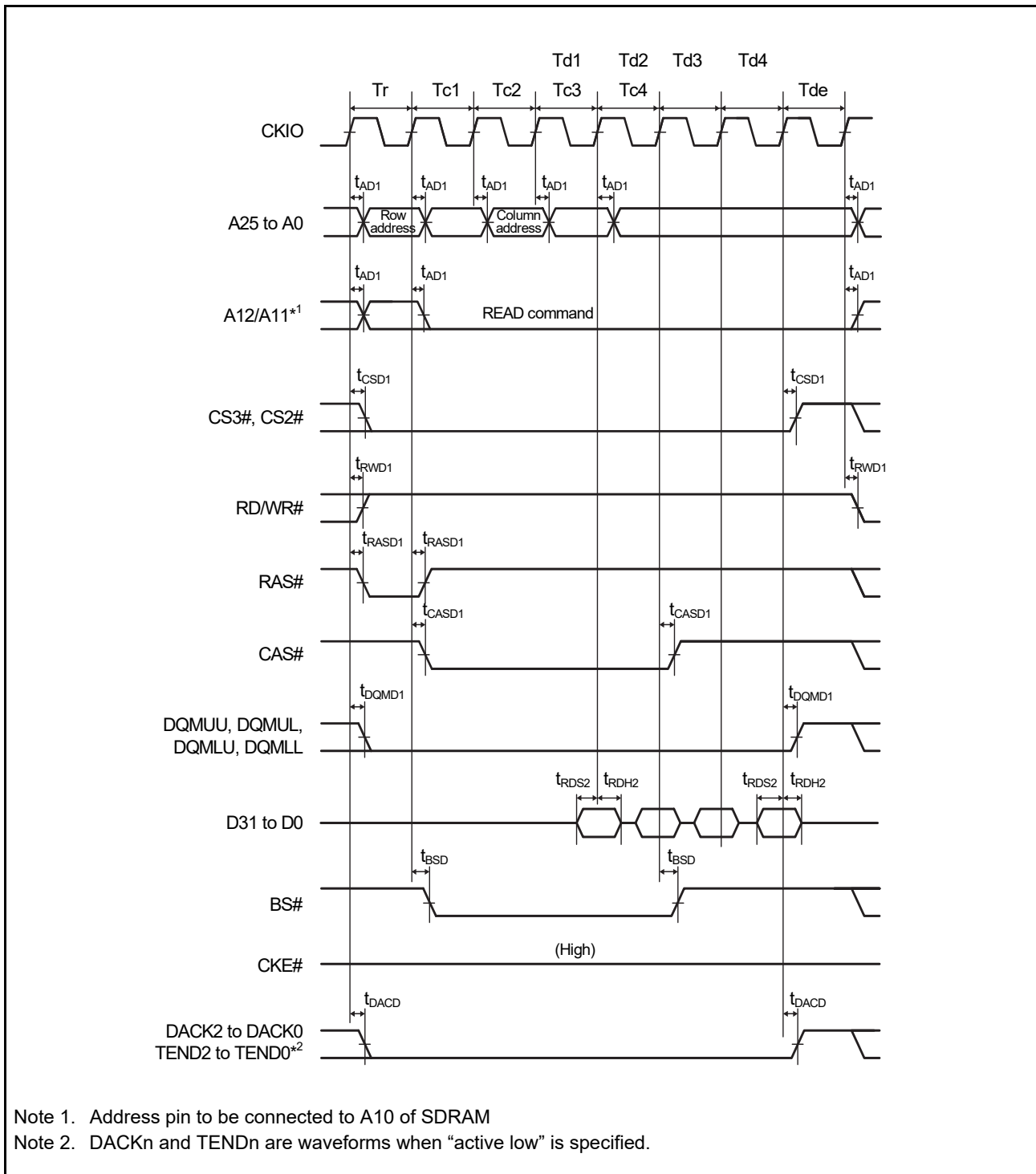



**Figure 2.26 Synchronous DRAM Burst-Write Bus Cycle (Write for 4 Cycles) (with Auto Precharge, WTRCD = 0 Cycles, TRWL = 1 Cycle)**



**Figure 2.27 Synchronous DRAM Burst-Write Bus Cycle (Write for 4 Cycles) (with Auto Precharge, WTRCD = 1 Cycle, TRWL = 1 Cycle)**



**Figure 2.28 Synchronous DRAM Burst-Read Bus Cycle (Read for 4 Cycles) (Bank Active Mode: ACT + READ Command, CAS Latency 2, WTRCD = 0 Cycles)**

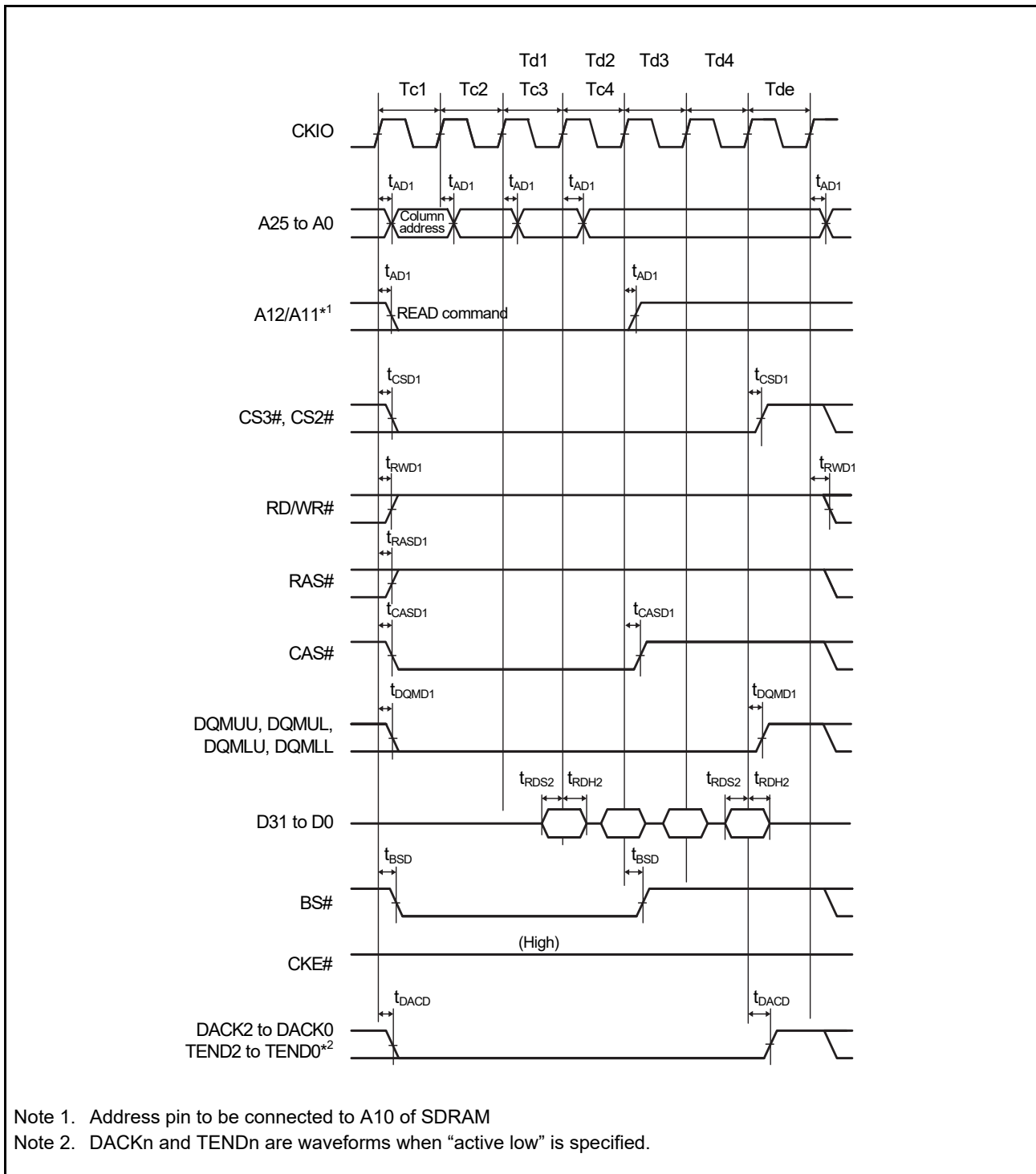

**Figure 2.29 Synchronous DRAM Burst-Read Bus Cycle (Read for 4 Cycles) (Bank Active Mode: READ Command, Same Row Address, CAS Latency 2, WTRCD = 0 Cycles)**

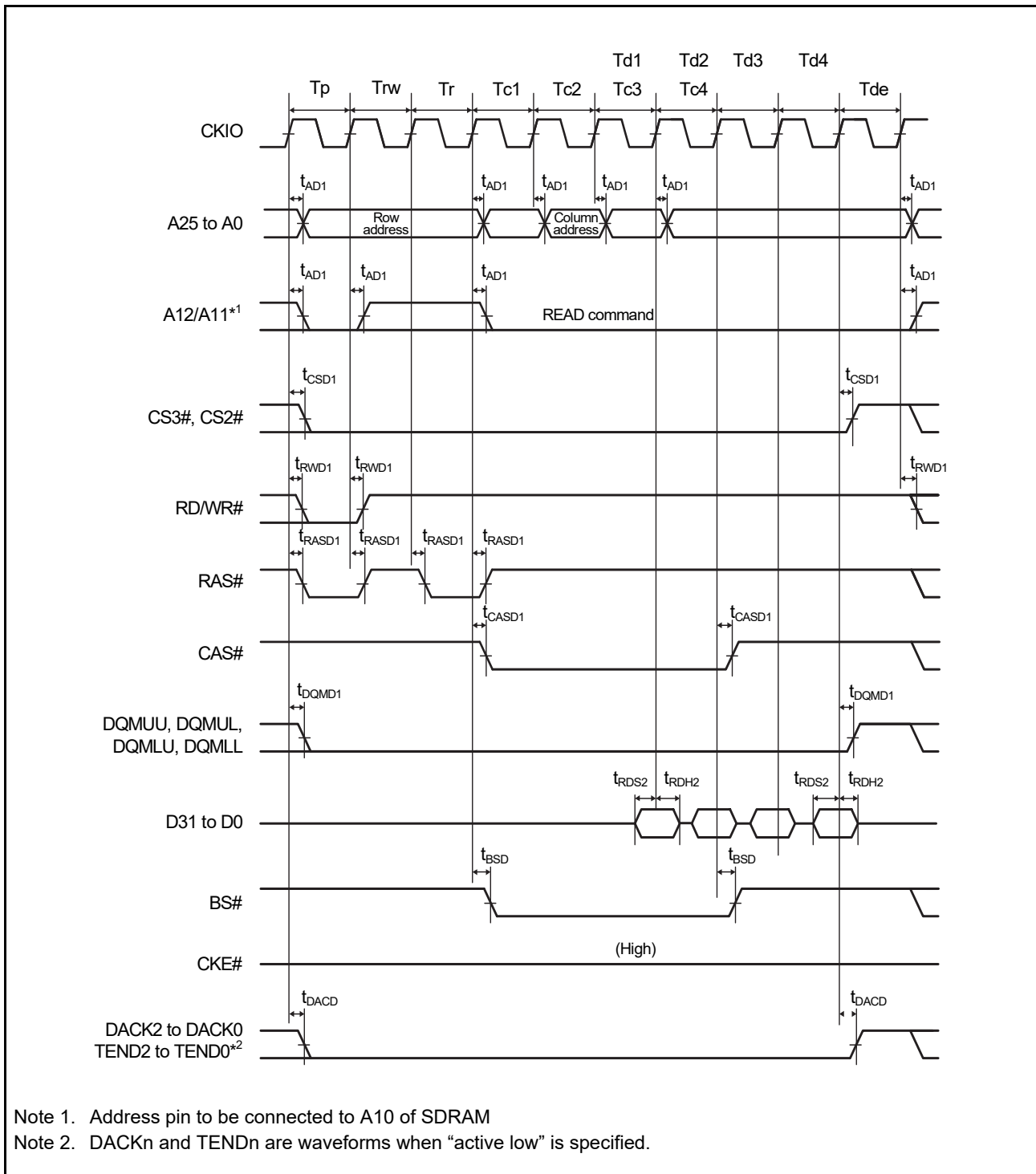

**Figure 2.30 Synchronous DRAM Burst-Read Bus Cycle (Read for 4 Cycles) (Bank Active Mode: PRE + ACT + READ Command, Different Row Address, CAS Latency 2, WTRCD = 0 Cycles)**

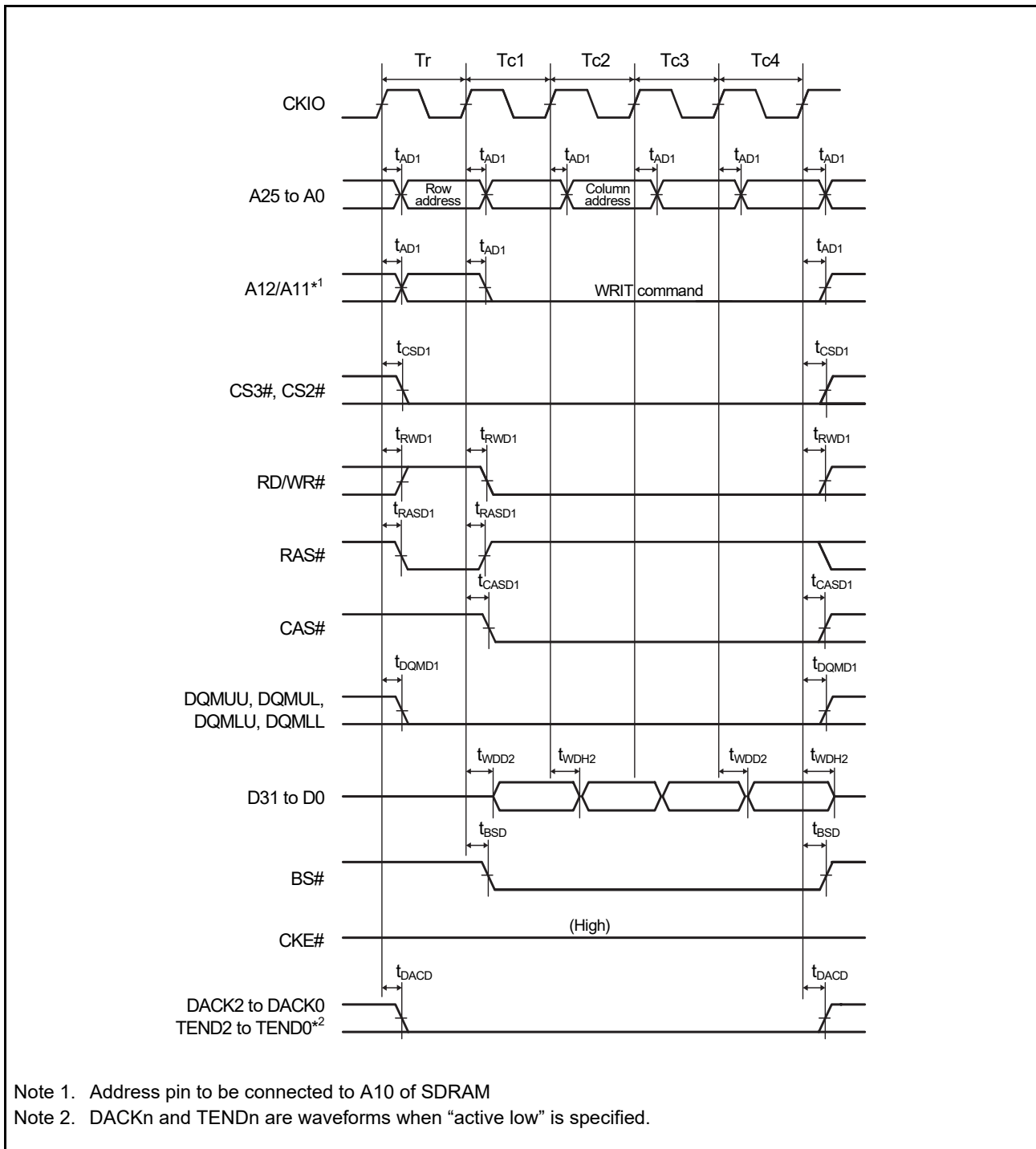

**Figure 2.31 Synchronous DRAM Burst-Write Bus Cycle (Write for 4 Cycles) (Bank Active Mode: ACT + WRITE Command, WTRCD = 0 Cycles, TRWL = 0 Cycles)**

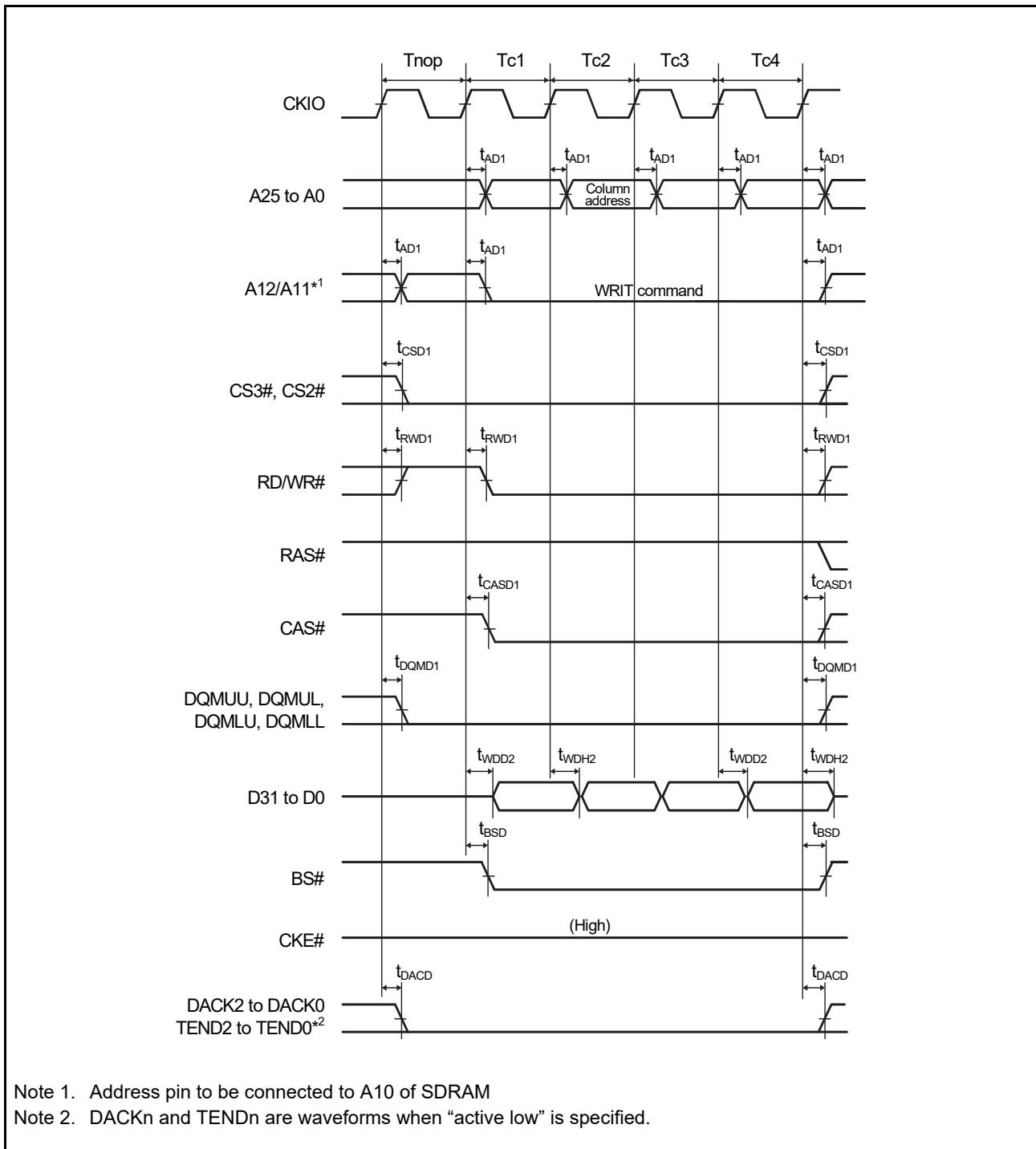

**Figure 2.32 Synchronous DRAM Burst-Write Bus Cycle (Write for 4 Cycles) (Bank Active Mode: WRITE Command, Same Row Address, WTRCD = 0 Cycles, TRWL = 0 Cycles)**

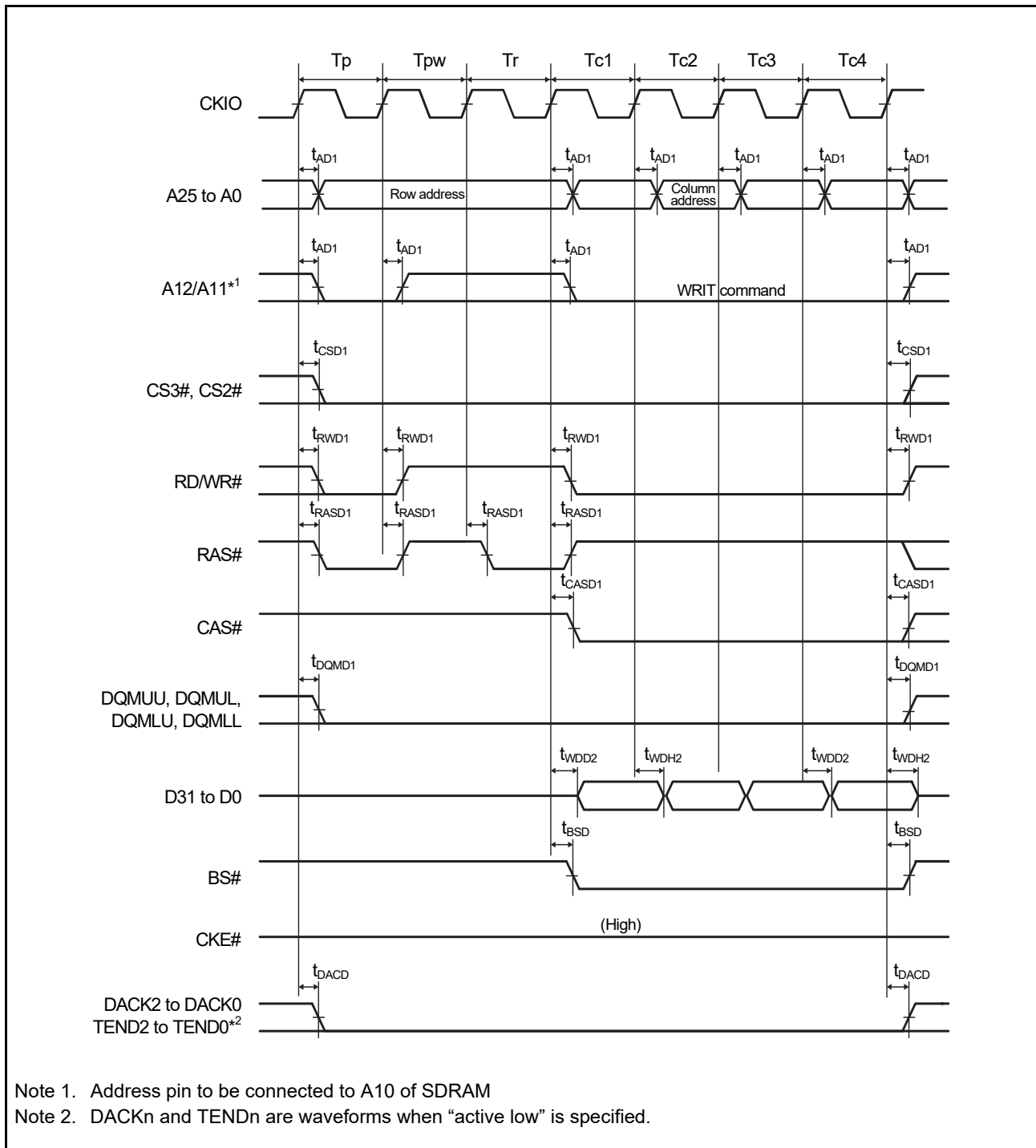

**Figure 2.33 Synchronous DRAM Burst-Write Bus Cycle (Write for 4 Cycles) (Bank Active Mode: PRE + ACT + WRITE Command, Different Row Address, WTRCD = 0 Cycles, TRWL = 0 Cycles)**



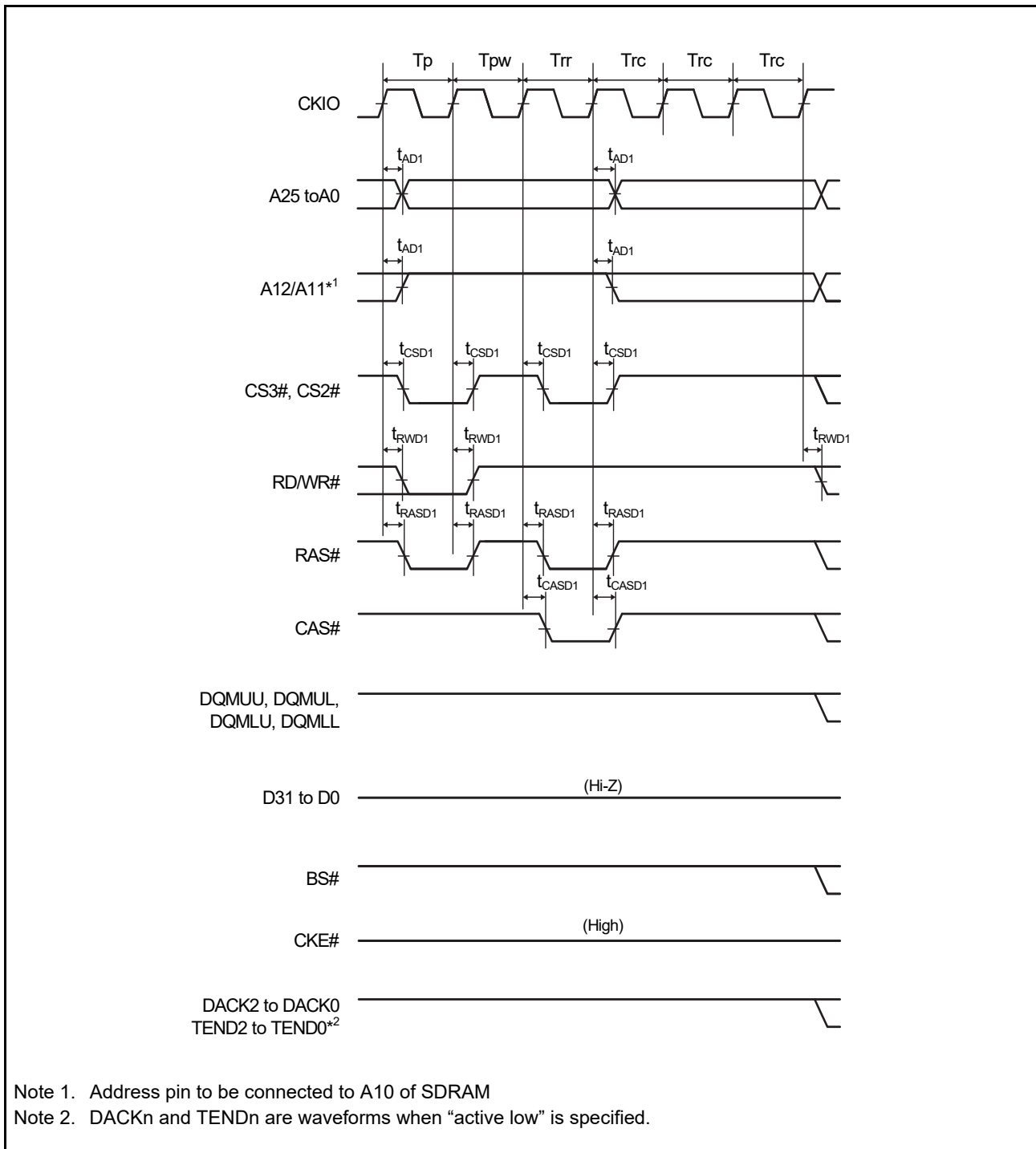

Figure 2.34 Synchronous DRAM Auto-Refresh Timing (WTRP = 1 Cycle, WTRC = 3 Cycles)

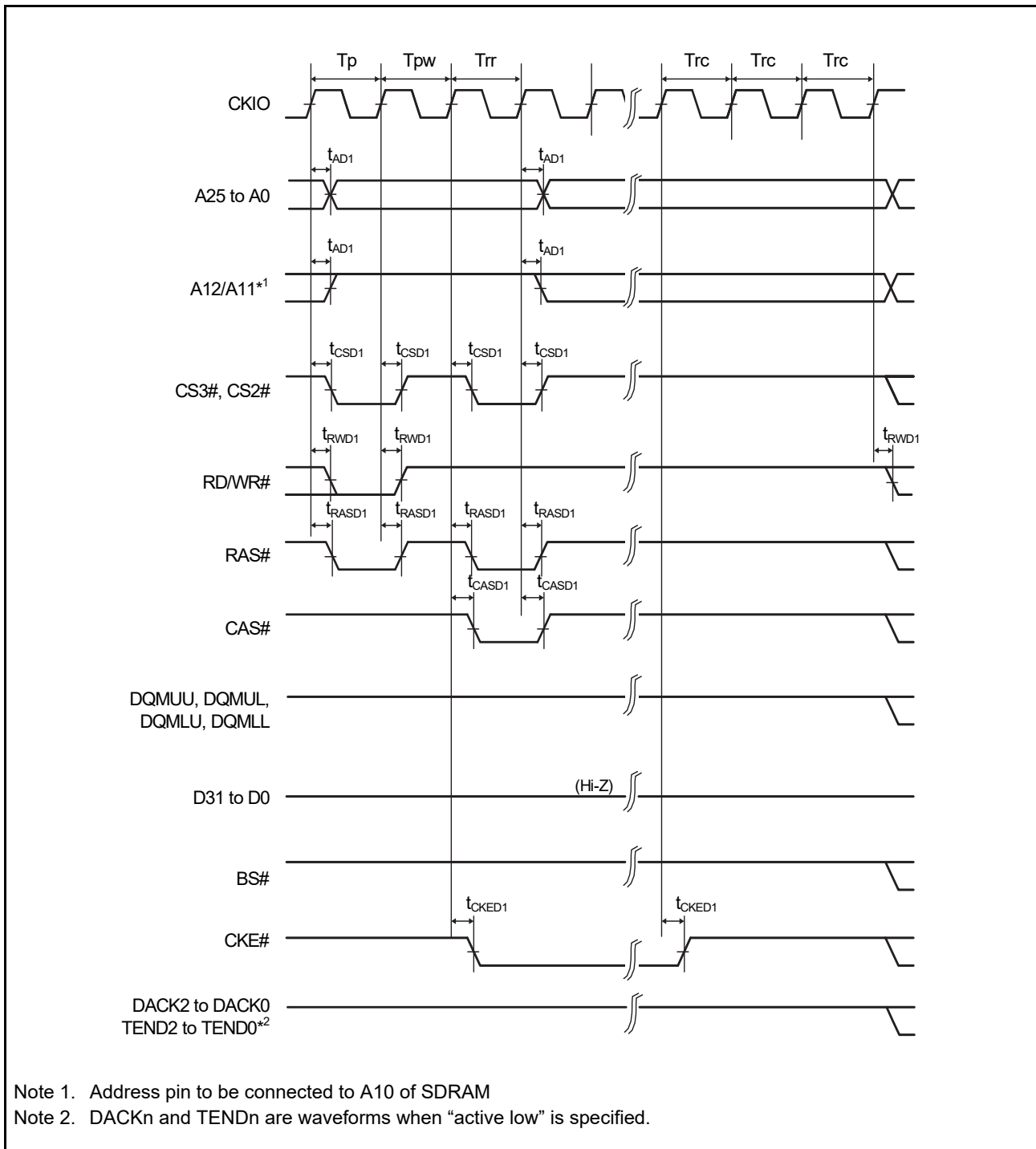

Figure 2.35 Synchronous DRAM Self-Refresh Timing (WTRP = 1 Cycle)

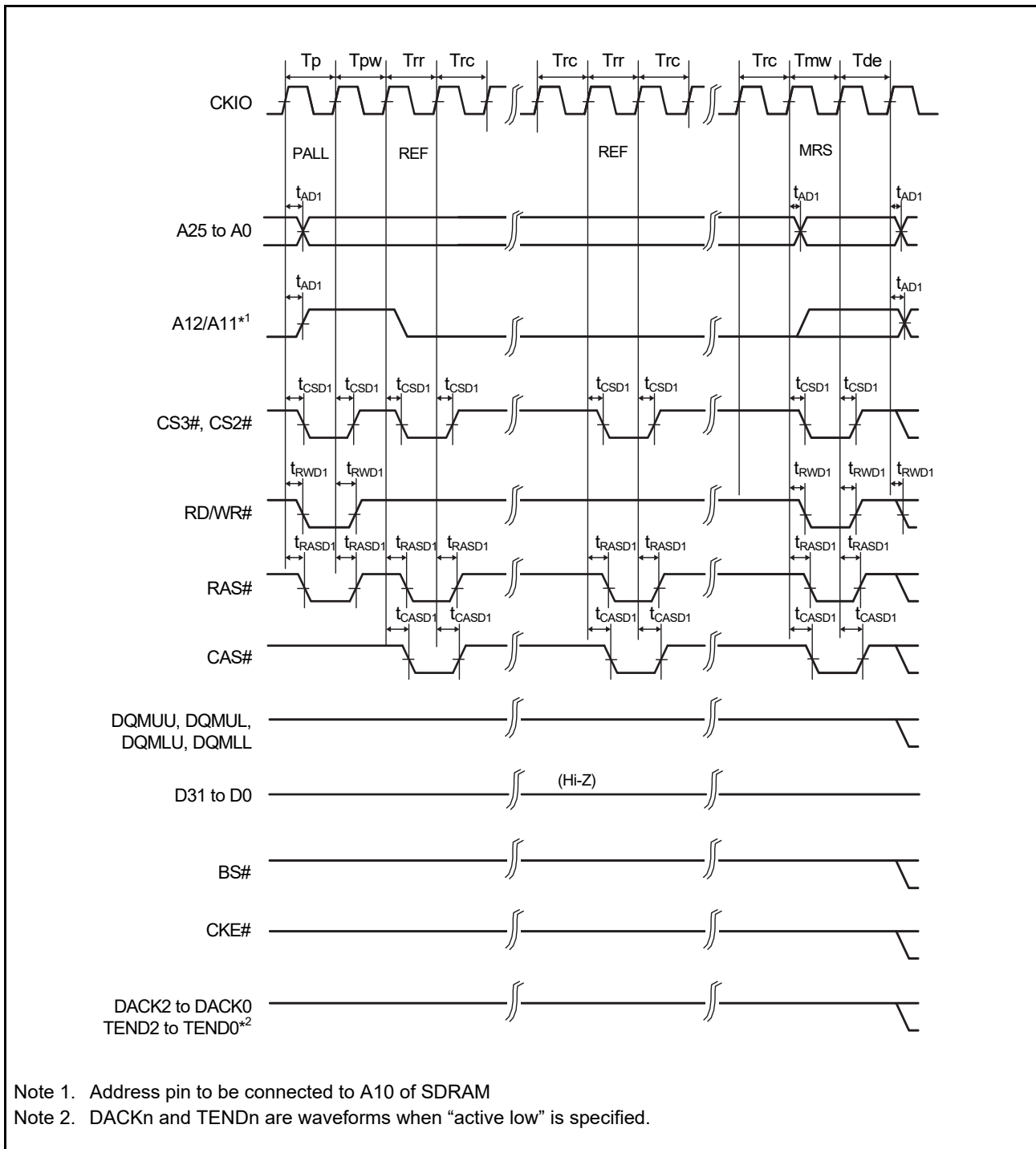

Figure 2.36 Synchronous DRAM Mode Register Write Timing (WTRP = 1 Cycle)

### 2.4.4 DMAC Timing

**Table 2.18 DMAC Timing**

Output load conditions:  $V_{OH} = V_{CCQ33} \times 0.5$ ,  $V_{OL1} = V_{CCQ33} \times 0.5$ ,  $C = 30$  pF

Item	Symbol	min <sup>*1</sup>	max	Unit	Test Conditions
DMAC	DREQ pulse width	$t_{DRQW}$	$t_{PBcyc} \times 2$	ns	Figure 2.37
	DACK and TEND delay time	$t_{DACD}$	0	10	ns

Note 1.  $t_{PBcyc}$ : PCLKB cycle

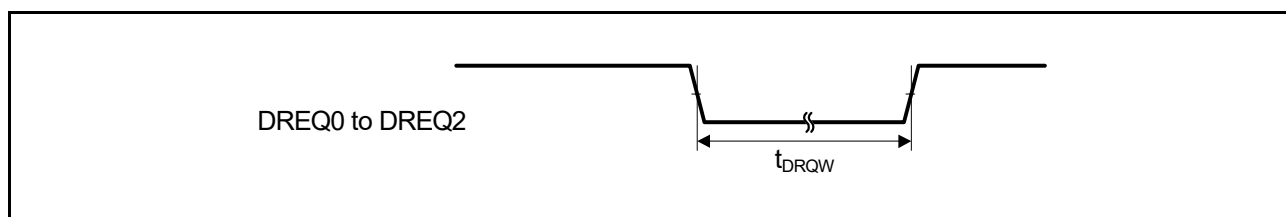

**Figure 2.37 DREQ Input Timing**

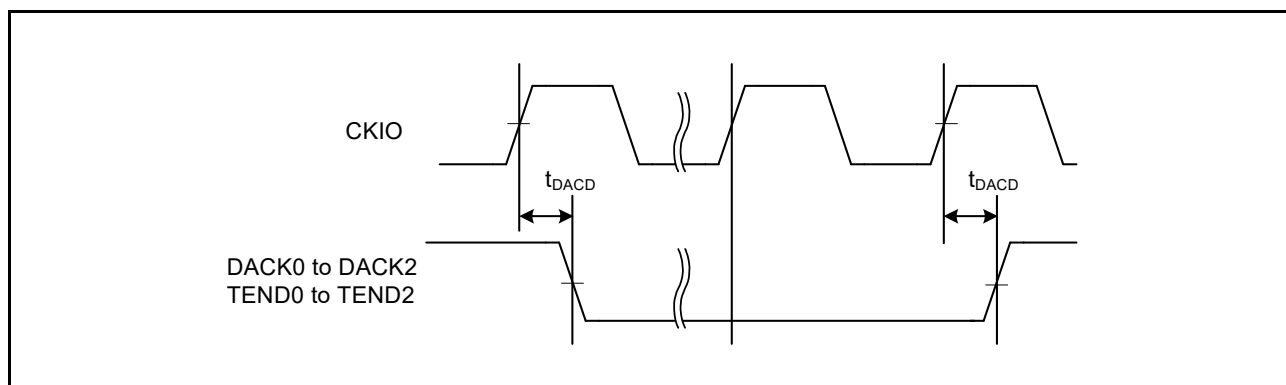

**Figure 2.38 DACK and TEND Output Timing**

## 2.4.5 On-Chip Peripheral Module Timing

### 2.4.5.1 I/O Port Timing

**Table 2.19 I/O Port Timing**

Item		Symbol	min	max	Unit*1	Test Conditions
I/O port	Input data pulse width	$t_{PRW}$	1.5	—	$t_{PBcyc}$	Figure 2.39

Note 1.  $t_{PBcyc}$ : PCLKB cycle

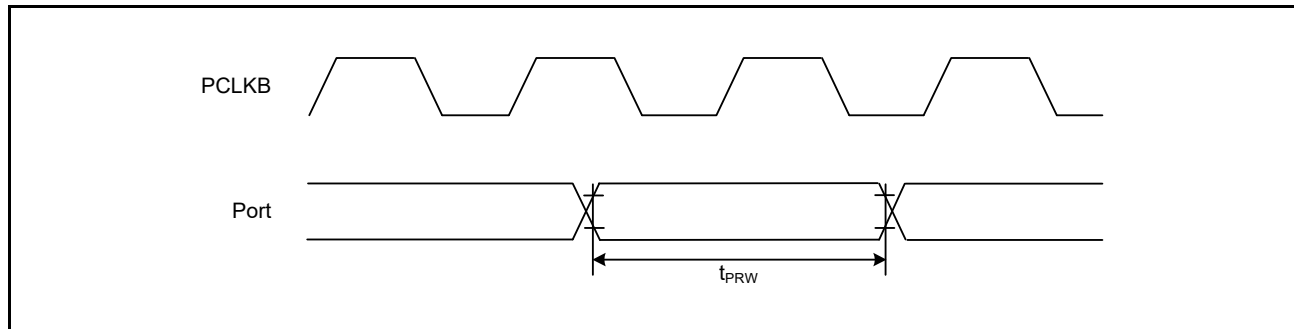

**Figure 2.39 I/O Port Input Timing**

### 2.4.5.2 TPUa Timing

**Table 2.20 TPUa Timing**

Item		Symbol	min	max	Unit*1	Test Conditions
TPUa	Input capture input pulse width	Single-edge setting	$t_{TICW}$	1.5	—	$t_{PDcyc}$ Figure 2.40
		Both-edge setting		2.5	—	
Timer clock pulse width	Single-edge	$t_{TCKWH}$ ,	1.5	—	$t_{PDcyc}$ Figure 2.41	
	Both-edge setting	$t_{TCKWL}$	2.5	—		
	Phase counting mode		2.5	—		

Note 1.  $t_{PDcyc}$ : PCLKD cycle

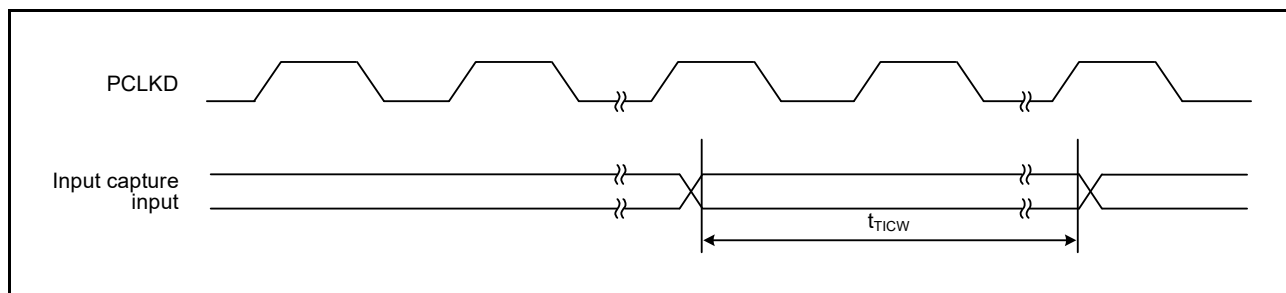

**Figure 2.40 TPUa Input Capture Input Timing**

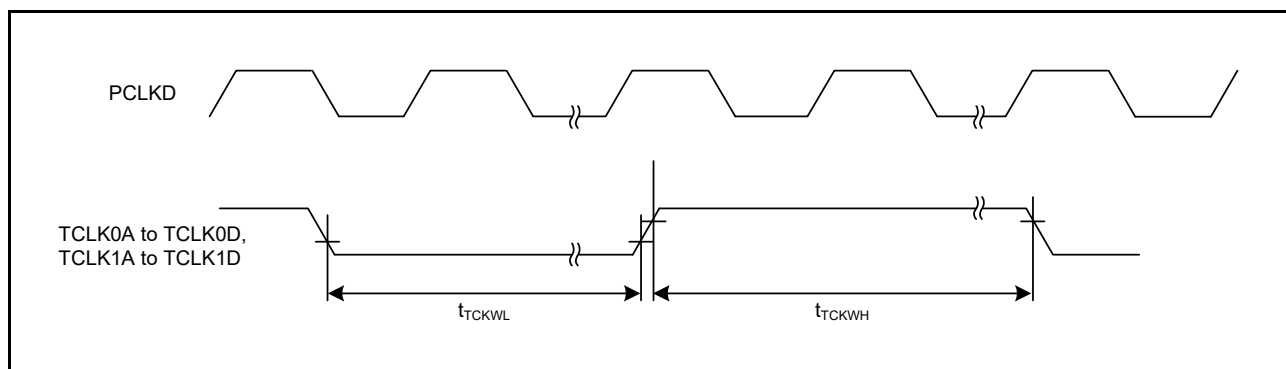

**Figure 2.41 TPUa Clock Input Timing**

### 2.4.5.3 CMTW Timing

**Table 2.21 CMTW Timing**

Item		Symbol	min	max	Unit*1	Test Conditions
CMTW	Input capture input pulse width	Single-edge setting	$t_{CMTWICW}$	1.5	—	$t_{PDcyc}$ Figure 2.42
		Both-edge setting		2.5	—	

Note 1.  $t_{PDcyc}$ : PCLKD cycle

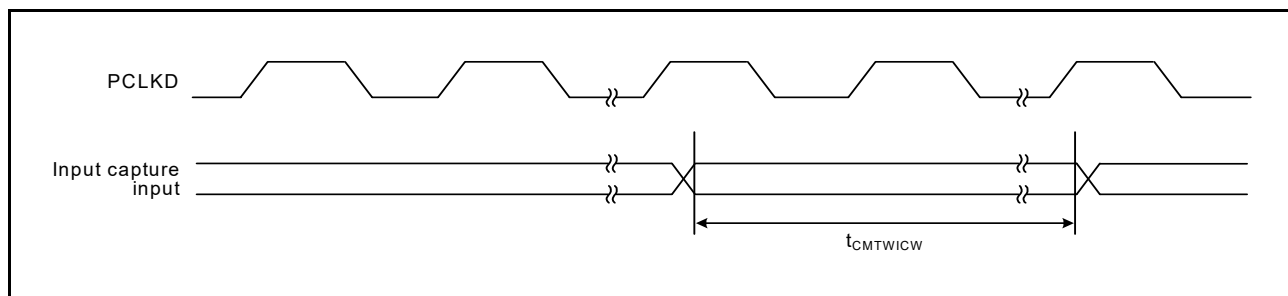

**Figure 2.42 CMTW Input Capture Input Timing**

### 2.4.5.4 MTU3a Timing

**Table 2.22 MTU3a Timing**

Item		Symbol	min	max	Unit*1	Test Conditions	
MTU3a	Input capture input pulse width	Single-edge setting	$t_{MTICW}$	1.5	—	$t_{PCyc}$	Figure 2.43
		Both-edge setting		2.5	—		
MTU3a	Timer clock pulse width	Single-edge setting	$t_{MTCKWH}, t_{MTCKWL}$	1.5	—	$t_{PCyc}$	Figure 2.44
		Both-edge setting		2.5	—		
		Phase counting mode		2.5	—		

Note 1.  $t_{PCyc}$ : PCLKC cycle

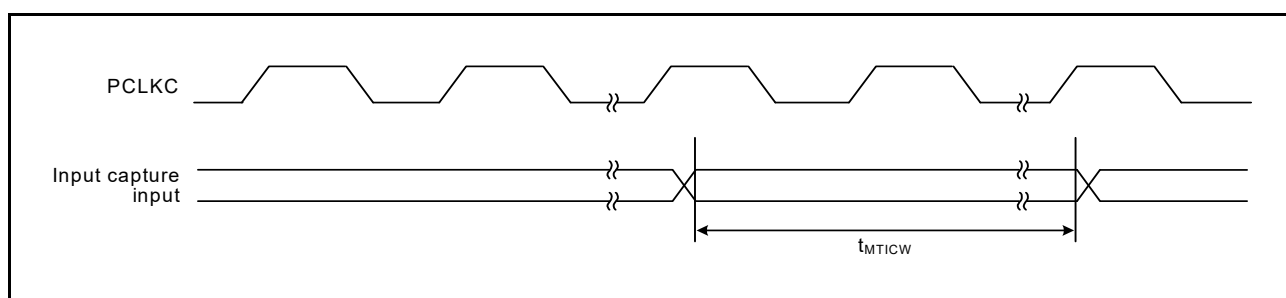

**Figure 2.43 MTU3a Input Capture Input Timing**

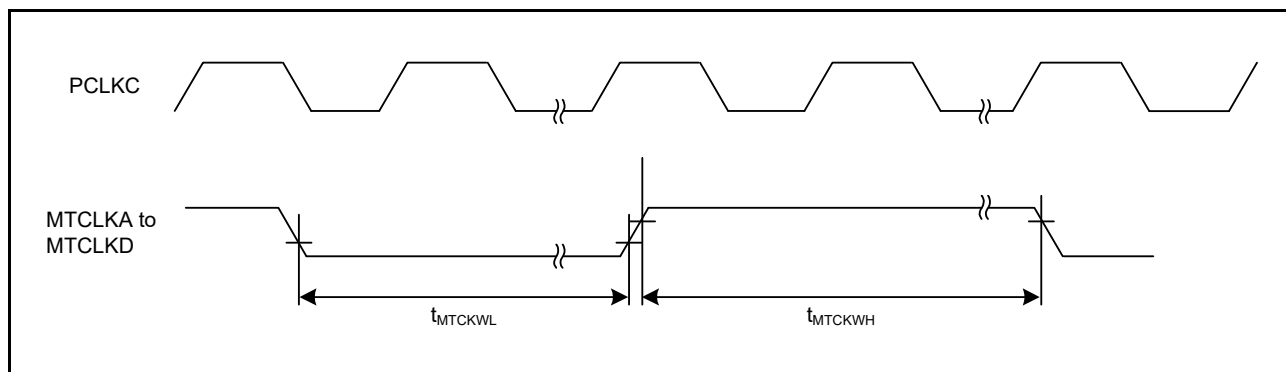

**Figure 2.44 MTU3a Clock Input Timing**



### 2.4.5.5 POE3 Timing

**Table 2.23 POE3 Timing**

Item	Symbol	min	max	Unit*1	Test Conditions
POE3 POEn# input pulse width	$t_{POEW}$	1.5	—	$t_{PDcyc}$	Figure 2.45

Note 1.  $t_{PDcyc}$ : PCLKD cycle

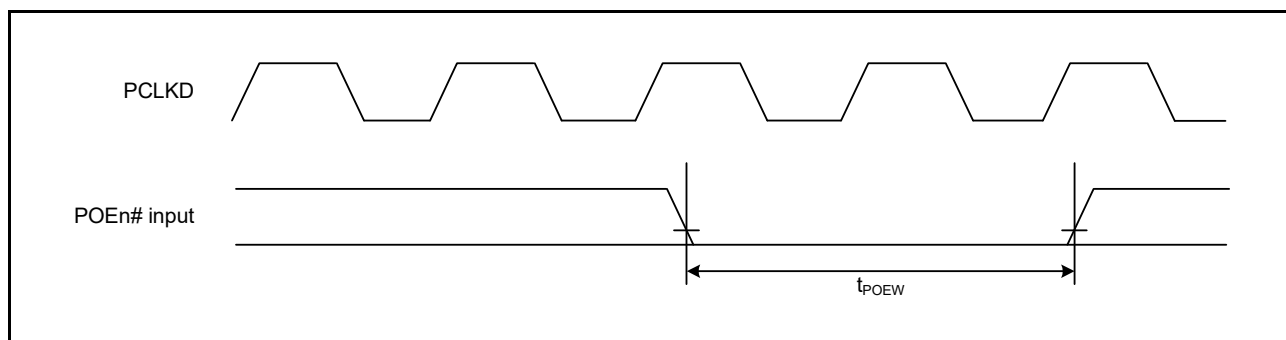

**Figure 2.45 POEn# Input Pulse Timing**

### 2.4.5.6 GPTa Timing

**Table 2.24 GPTa Timing**

Item		Symbol	min	max	Unit*1	Test Conditions
GPTa	Input capture input pulse width	Single-edge setting	$t_{GTICW}$	3	—	$t_{PCyc}$ Figure 2.46
		Both-edge setting		5	—	
GPTa	External trigger input pulse width	Single-edge setting	$t_{GTEW}$	1.5	—	$t_{PCyc}$ Figure 2.47
		Both-edge setting		2.5	—	

Note 1.  $t_{PCyc}$ : PCLKC cycle

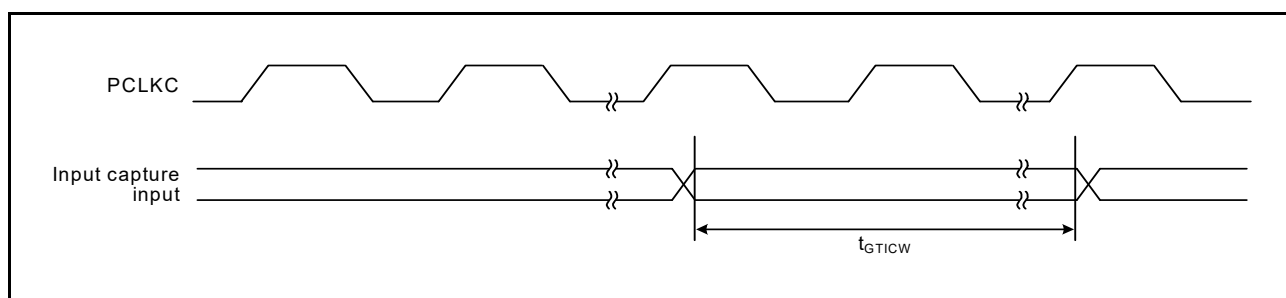

**Figure 2.46 GPTa Input Capture Input Timing**

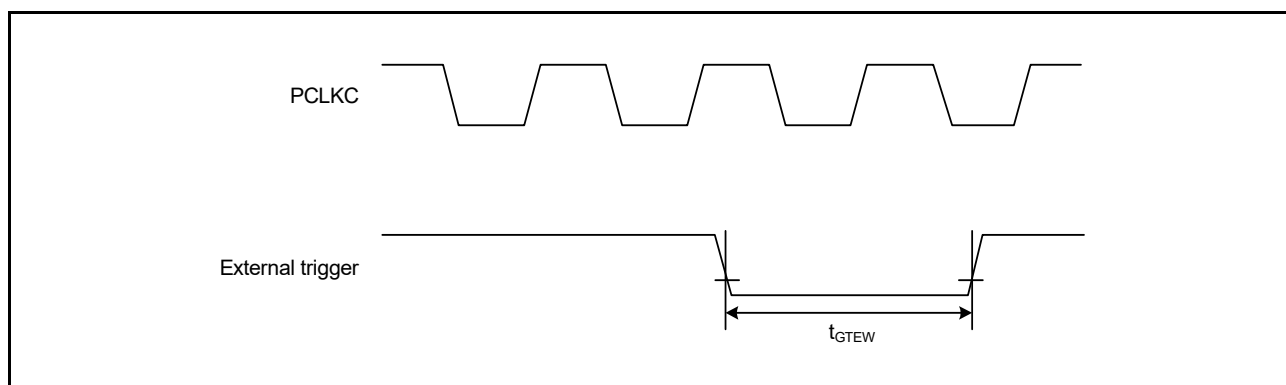

**Figure 2.47 GPTa External Trigger Input Timing**

### 2.4.5.7 A/D Converter Trigger Timing

**Table 2.25 A/D Converter Trigger Timing**

Item		Symbol	min	max	Unit*1	Test Conditions
A/D converter	A/D converter trigger	ADTRG0	$t_{TRGW}$	1.5	—	$t_{PFcyc}$ Figure 2.48
	input pulse width	ADTRG1	$t_{TRGW}$	1.5	—	$t_{PGcyc}$ Figure 2.49

Note 1.  $t_{PFcyc}$ : PCLKF cycle,  $t_{PGcyc}$ : PCLKG cycle

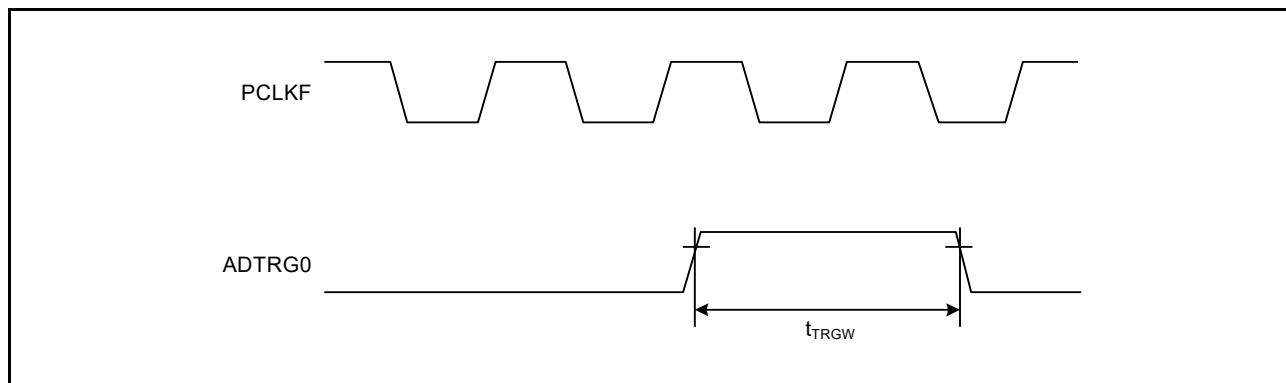

**Figure 2.48 A/D Converter Trigger Input Timing (ADTRG0)**

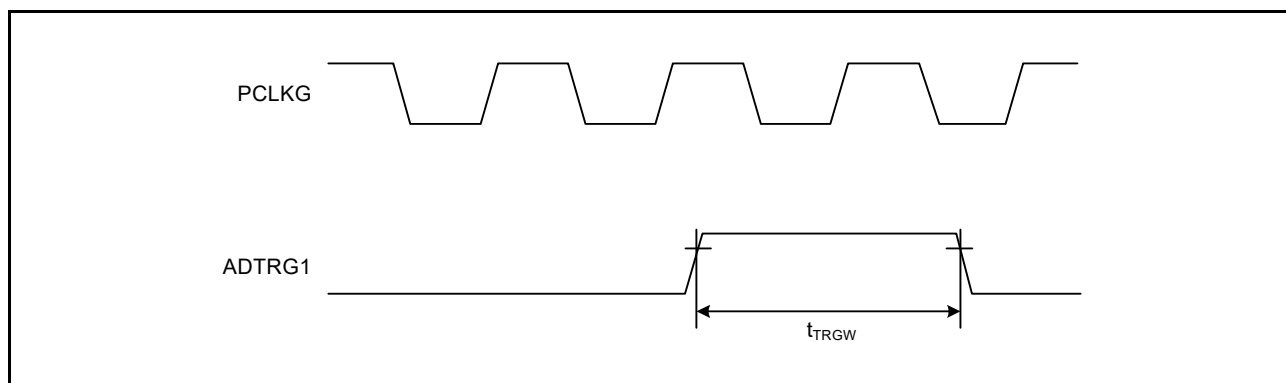

**Figure 2.49 A/D Converter Trigger Input Timing (ADTRG1)**

## 2.4.5.8 SCIFA Timing

**Table 2.26 SCIFA Timing**Output load conditions:  $V_{OH} = V_{CCQ33} \times 0.5$ ,  $V_{OL1} = V_{CCQ33} \times 0.5$ ,  $C = 30$  pF

Item		Symbol	min*1	max*1	Unit*1	Test Conditions
SCIFA Input clock cycle	Asynchronous	$t_{Scyc}$	4	—	$t_{SEcyc}$	Figure 2.50
	Clock synchronous		12	—		
Input clock pulse width		$t_{SCKW}$	0.4	0.6	$t_{Scyc}$	
Input clock rising time		$t_{SCKr}$	—	5	ns	
Input clock falling time		$t_{SCKf}$	—	5	ns	
Output clock cycle	Asynchronous*2	$t_{Scyc}$	8	—	$t_{SEcyc}$	
	Clock synchronous		4	—		
Output clock pulse width		$t_{SCKW}$	0.4	0.6	$t_{Scyc}$	
Output clock rising time		$t_{SCKr}$	—	9	ns	
Output clock falling time		$t_{SCKf}$	—	9	ns	
Transmit data delay time	Internal clock	$t_{TXD}$	-10	10	ns	Figure 2.51
	External clock		$3 \times t_{SEcyc}$	$4 \times t_{SEcyc} + 20$		
Receive data setup time	Internal clock	$t_{RXS}$	$3 \times t_{SEcyc} + 20$	—	ns	
	External clock		$t_{SEcyc} + 10$	—		
Receive data hold time	Internal clock	$t_{RXH}$	$-3 \times t_{SEcyc}$	—	ns	
	External clock		$2 \times t_{SEcyc} + 10$	—		

Note 1.  $t_{SEcyc}$ : SERICLK cycle

Note 2. When the SEMR.ABCS0 bit = 1 and the SEMR.BGDM bit = 1

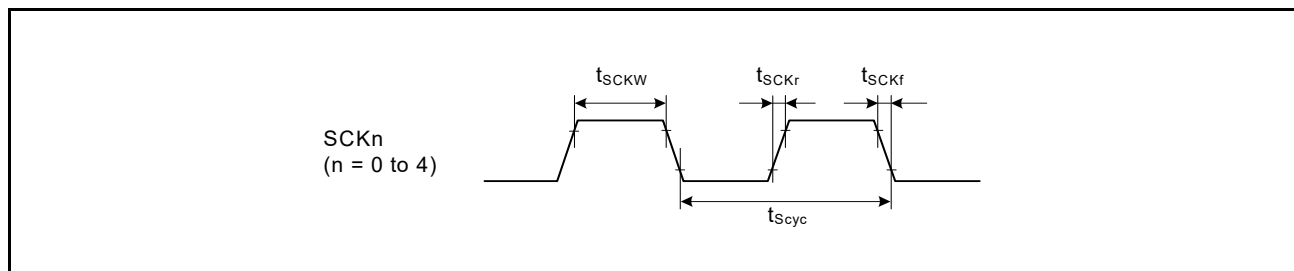
**Figure 2.50 SCK Clock Input Timing**

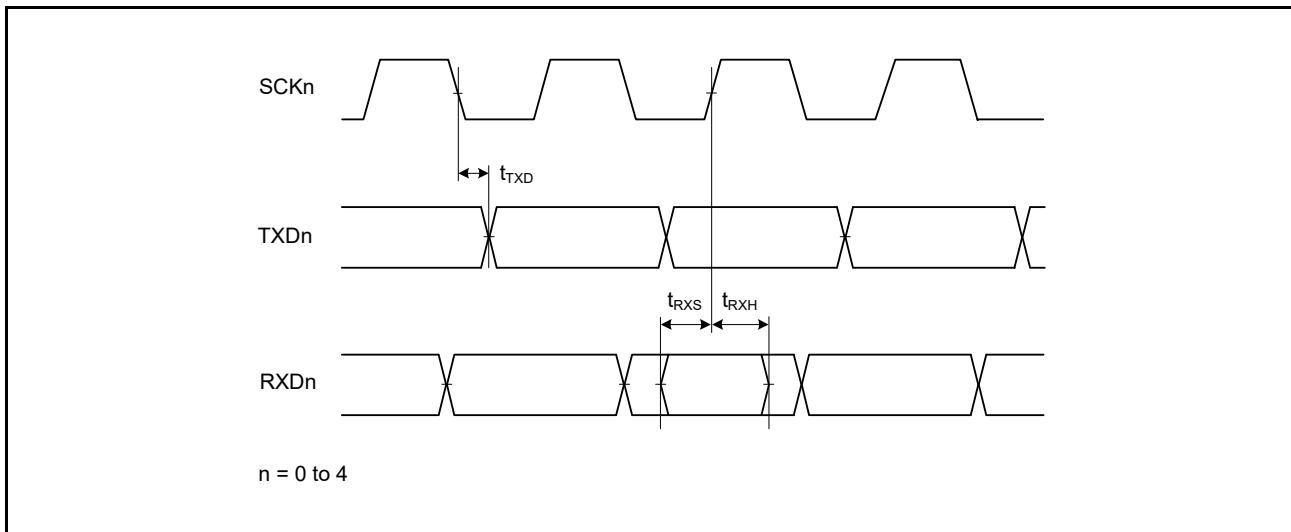

Figure 2.51 SCIFA Input/Output Timing/Clock Synchronous Mode

## 2.4.5.9 RSPIa Timing

**Table 2.27 RSPIa Timing**Output load conditions:  $V_{OH} = V_{CCQ33} \times 0.5$ ,  $V_{OL1} = V_{CCQ33} \times 0.5$ ,  $C = 30$  pF

Item		Symbol*1	Min*1	Max*1	Unit*1	Test Conditions	
RSPIa	RSPCK clock cycle	Master	$t_{SPcyc}$	4	4096	$t_{SEcyc}$	Figure 2.52
		Slave*4		8	4096		
	RSPCK clock high level pulse width	Master	$t_{SPCKWH}$	$(t_{SPcyc} - t_{SPCKR} - t_{SPCKF}) / 2 - 3$	—	ns	
		Slave		0.4	—		
	RSPCK clock low level pulse width	Master	$t_{SPCKWL}$	$(t_{SPcyc} - t_{SPCKR} - t_{SPCKF}) / 2 - 3$	—	ns	
		Slave		0.4	—		
	RSPCK clock rising/falling time	Output	$t_{SPCKr}$	—	9	ns	
		Input	$t_{SPCKf}$	—	10		
	Data input setup time	Master	$t_{SU}$	6	—	ns	Figure 2.53 to Figure 2.56
		Slave		$8 - t_{SEcyc}$	—		
	Data input hold time	Master	$t_H$	$t_{SEcyc}$	—	ns	
		Slave		$8 + 2 \times t_{SEcyc}$	—		
	SSL setup time	Master	$t_{LEAD}$	$N \times t_{Spcyc} - 3^{*2}$	$N \times t_{Spcyc} + 3^{*2}$	ns	
		Slave		4	—		
	SSL hold time	Master	$t_{LAG}$	$N \times t_{Spcyc} - 3^{*3}$	$N \times t_{Spcyc} + 3^{*3}$	ns	
		Slave		4	—		
	Data output delay time	Master	$t_{OD}$	—	6	ns	
		Slave		—	$3 \times t_{SEcyc} + 20^{*4}$		
	Data output hold time	Master	$t_{OH}$	0	—	ns	
		Slave		0	—		
	Continuous transmission delay	Master	$t_{TD}$	$t_{SPcyc} + 2 \times t_{SEcyc}$	$8 \times t_{SPcyc} + 2 \times t_{SEcyc}$	ns	
		Slave		$4 \times t_{SEcyc}$	—		
	MOSI, MISO rising/falling time	Output	$t_{Dr}$ , $t_{Df}$	—	9	ns	
		Input		—	10		
	SSL rising/falling time	Output	$t_{SSLr}$ , $t_{SSLf}$	—	9	ns	
		Input		—	10		
	Slave access time		$t_{SA}$	—	4	$t_{SEcyc}$	Figure 2.55 to Figure 2.56
	Slave output release time		$t_{REL}$	—	3	$t_{SEcyc}$	

Note 1.  $t_{SEcyc}$ : SERICLK cycleNote 2.  $N = SPCKD$  set value + 1 (1 to 8)Note 3.  $N = SSLND$  set value + 1 (1 to 8)

Note 4. The data output delay time may become longer than half a cycle of the RSPCK clock depending on the bit rate setting. Be sure to satisfy the conditions required for the electrical characteristics of the master device.

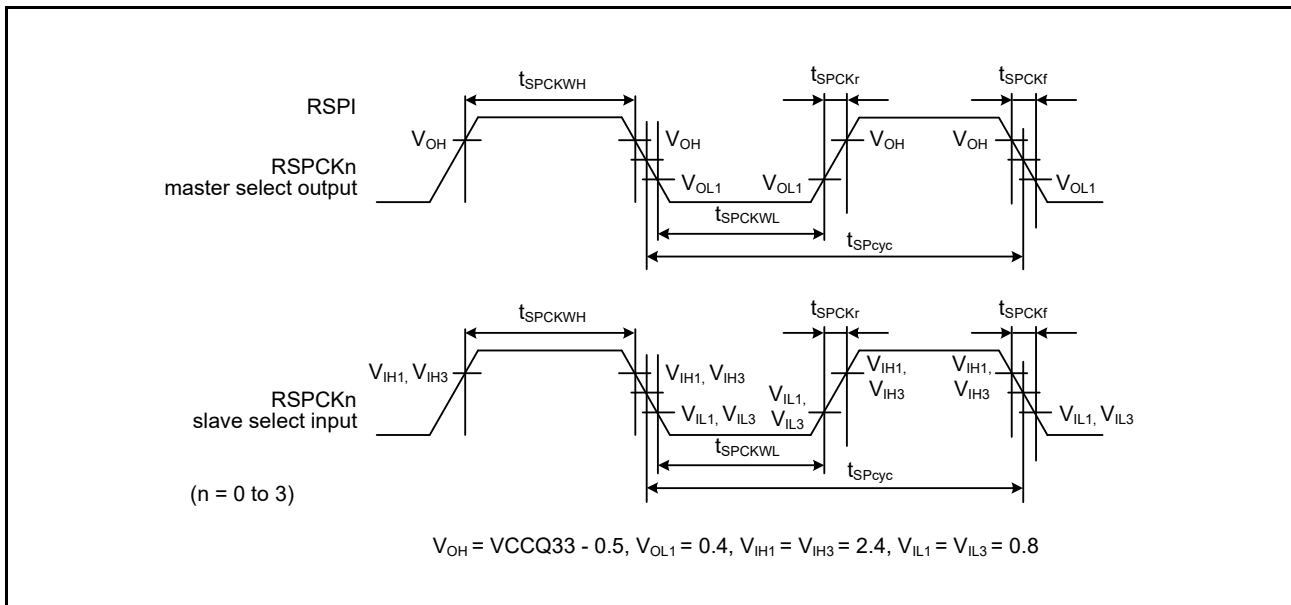

Figure 2.52 RSPIa Clock Timing

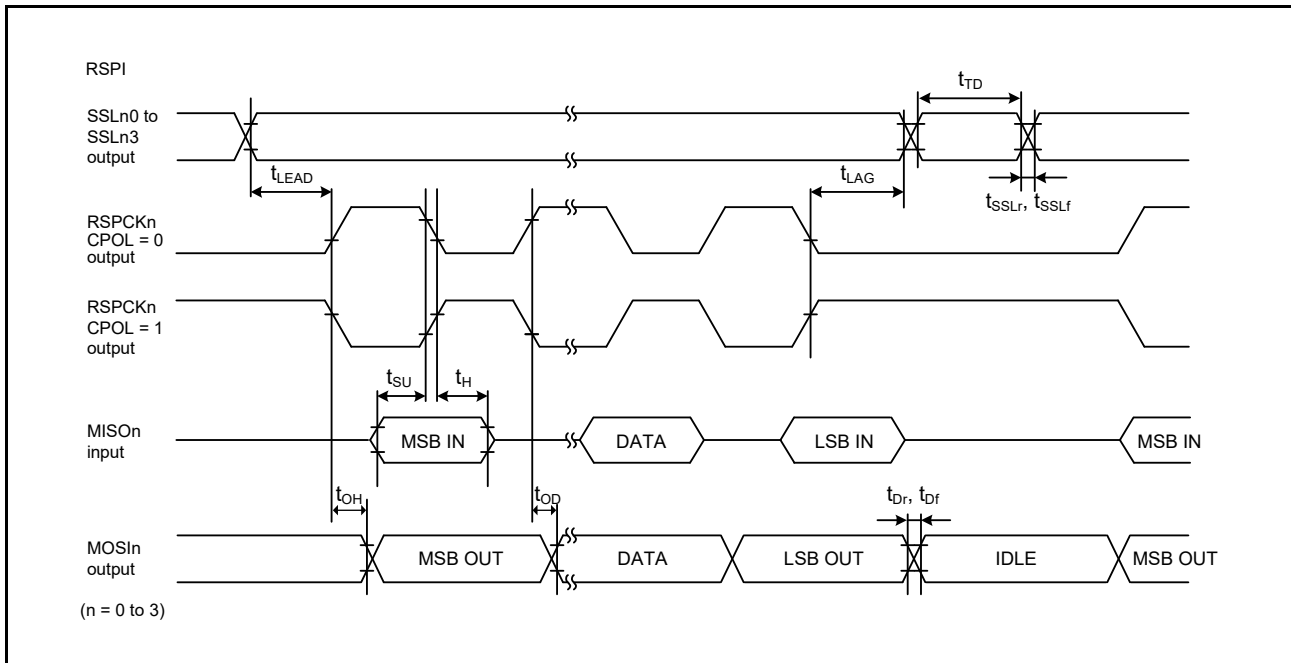

Figure 2.53 RSPIa Timing (Master, CPHA = 0)

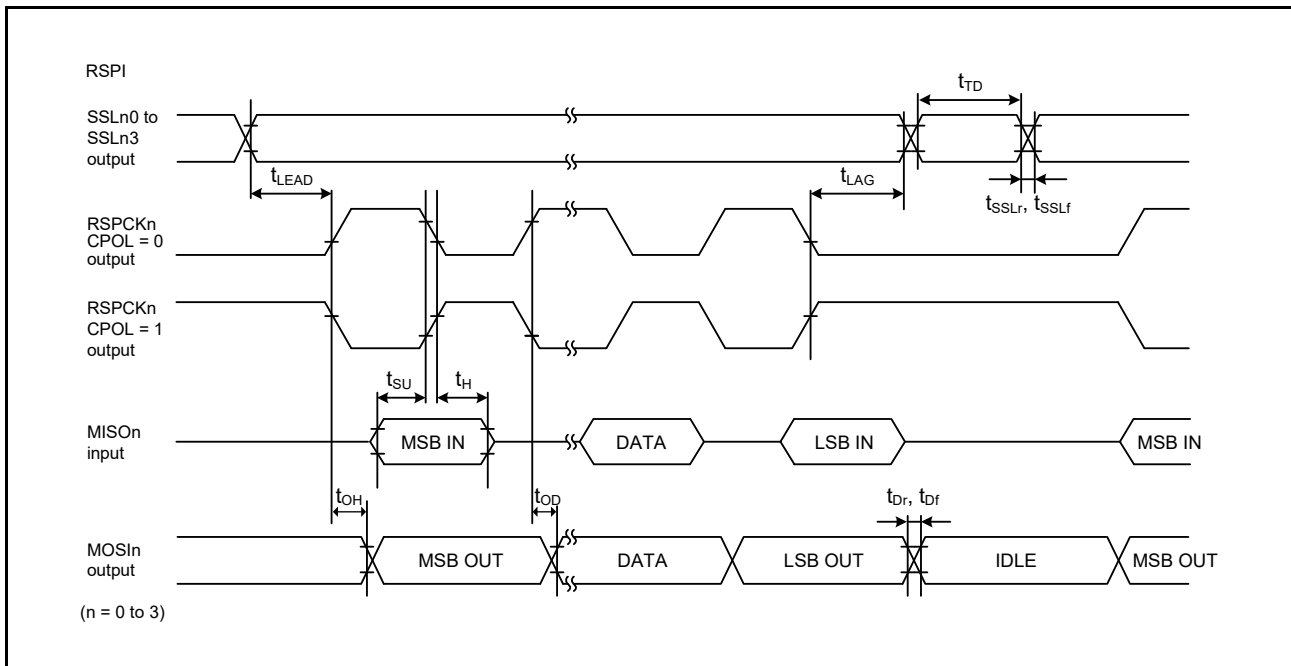

Figure 2.54 RSPIa Timing (Master, CPHA = 1)

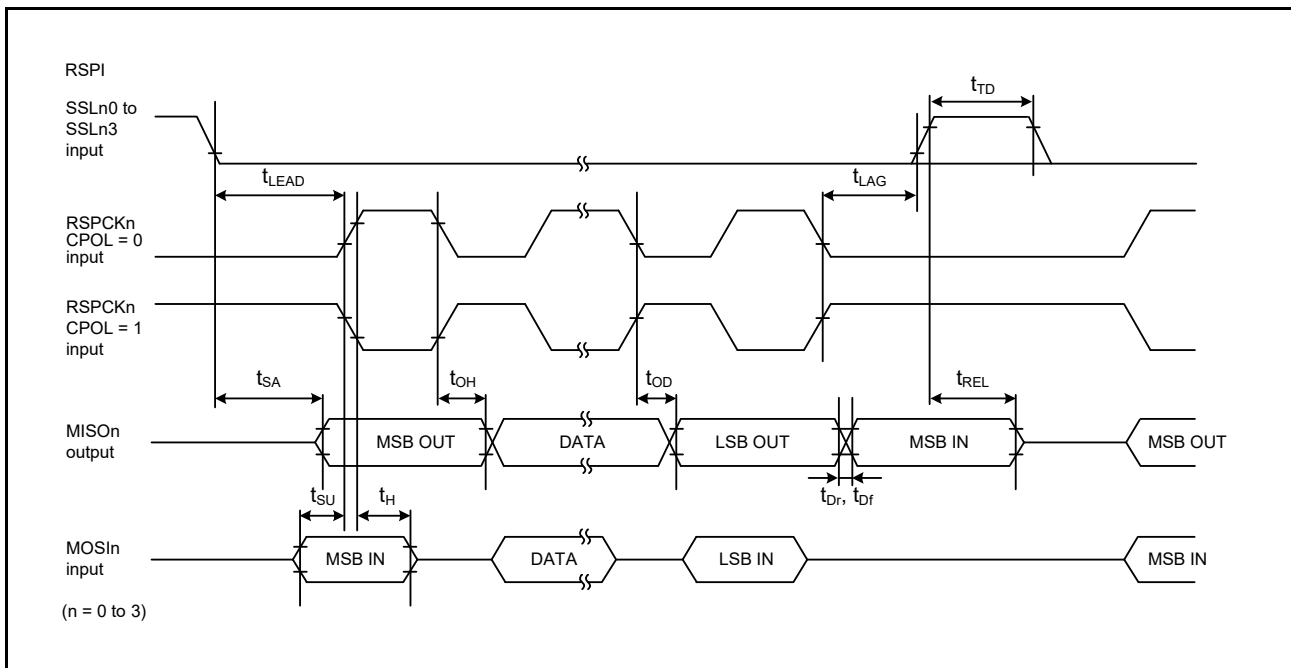

Figure 2.55 RSPI Timing (Slave, CPHA = 0)



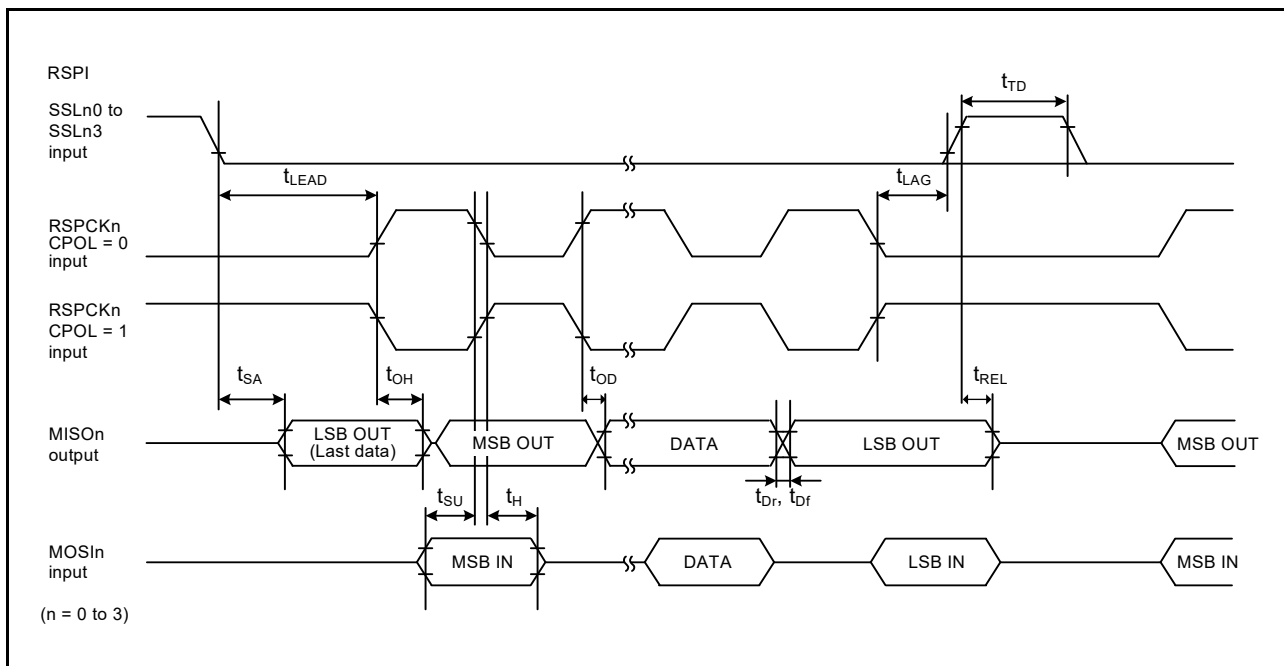
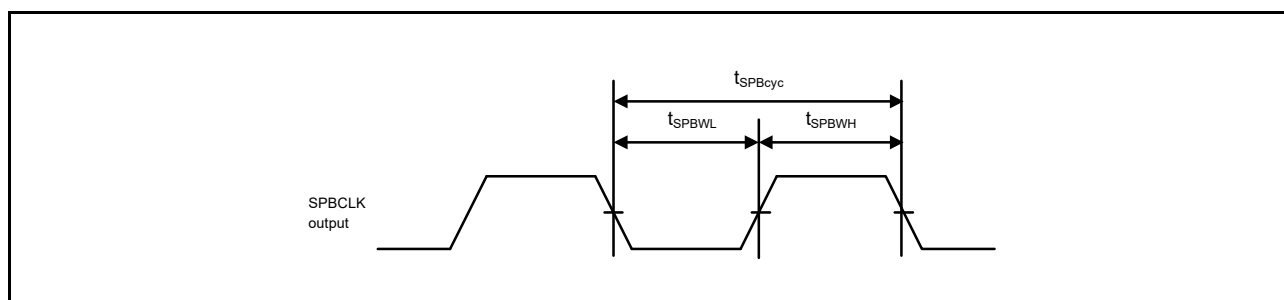

Figure 2.56 RSPI Timing (Slave, CPHA = 1)

## 2.4.5.10 SPIBSC Timing

**Table 2.28 SPIBSC Timing**Output load conditions:  $V_{OH} = V_{CCQ33} \times 0.5$ ,  $V_{OL1} = V_{CCQ33} \times 0.5$ ,  $C = 30$  pF

Item	Symbol	min	max	Unit*1	Test Conditions	
SPIBSC	SPBCLK clock cycle	$t_{SPBcyc}$	2	4080	$t_{PAcyc}$	Figure 2.57
	SPBCLK high level pulse width	$t_{SPBWH}$	0.45	0.55	$t_{SPBcyc}$	
	SPBCLK low level pulse width	$t_{SPBWL}$	0.45	0.55	$t_{SPBcyc}$	
	Data input setup time	$t_{SU}$	3.5	—	ns	Figure 2.58, Figure 2.59, Figure 2.60
	Data input hold time	$t_H$	0.5	—	ns	
	SSL setup time	$t_{LEAD}$	$1 \times t_{SPBcyc} - 3$	$8 \times t_{SPBcyc}$	ns	
	SSL hold time	$t_{LAG}$	$1.5 \times t_{SPBcyc}$	$8.5 \times t_{SPBcyc} + 3$	ns	
	Continuous transfer delay time	$t_{TD}$	1	8	$t_{SPBcyc}$	
	Data output delay time	$t_{OD}$	—	3.6	ns	
	Data output hold time	$t_{OH}$	-1	—	ns	
	Data output buffer on time	$t_{BON}$	—	3.6	ns	Figure 2.61, Figure 2.62, Figure 2.63
	Data output buffer off time	$t_{BOFF}$	-7	0	ns	

Note 1.  $t_{PAcyc}$ : PCLKA cycle**Figure 2.57 SPIBSC Clock Timing**

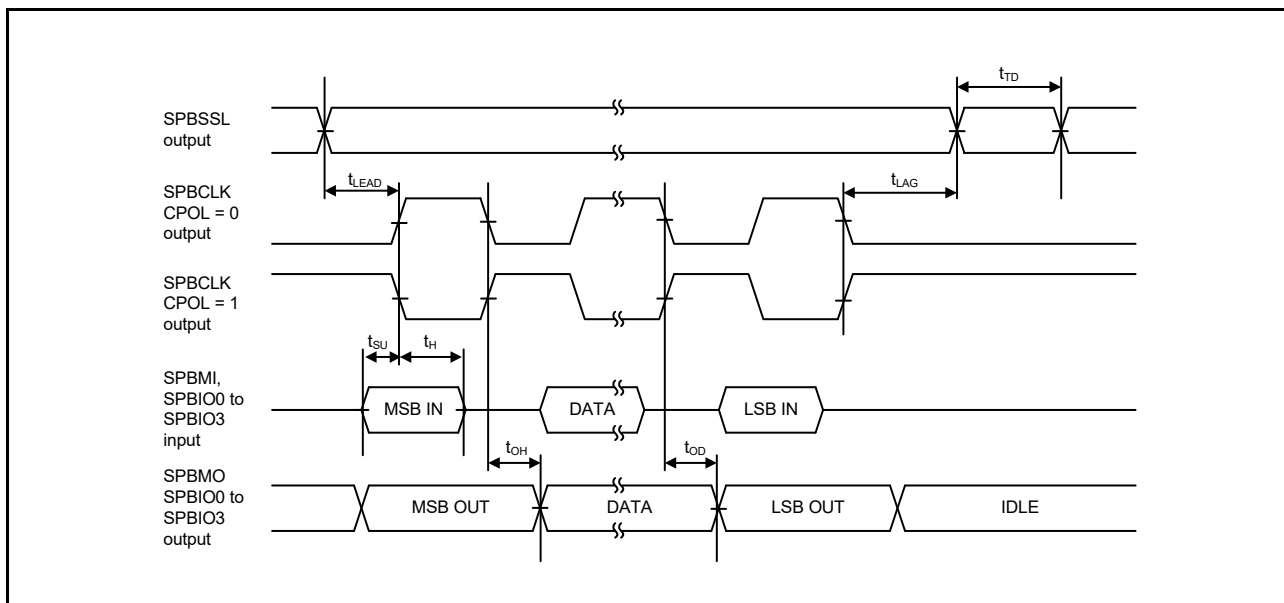

Figure 2.58 SPIBSC Transmit/Receive Timing (CPHAT = 0, CPHAR = 0)

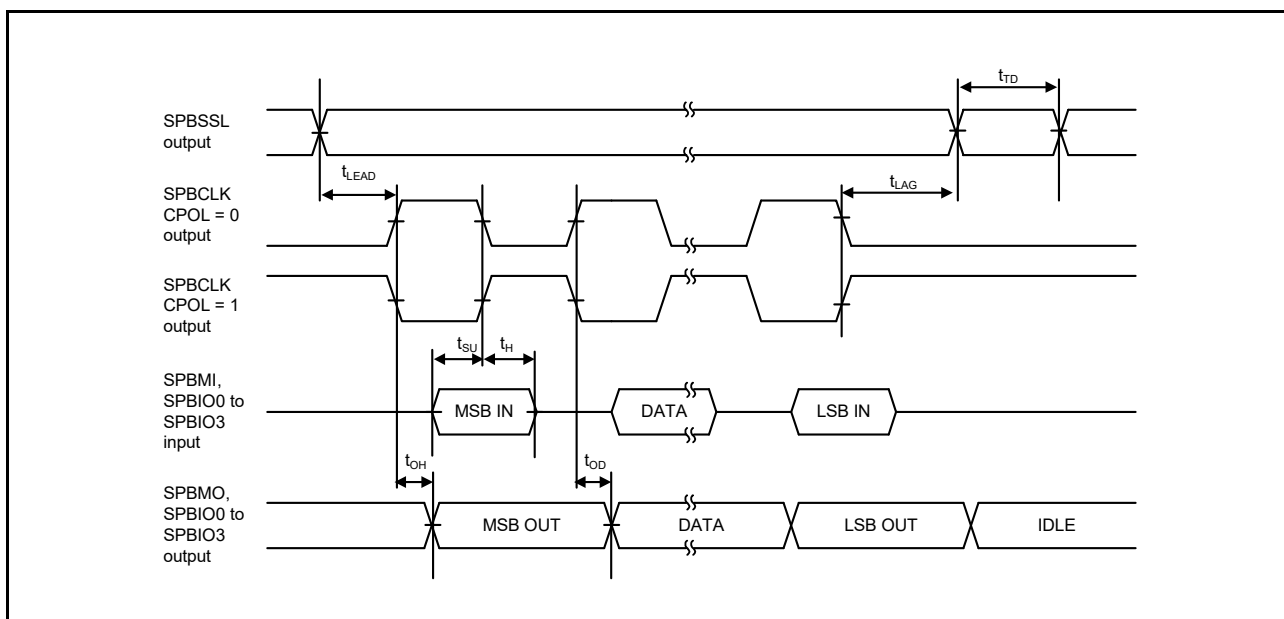

Figure 2.59 SPIBSC Transmit/Receive Timing (CPHAT = 1, CPHAR = 1)

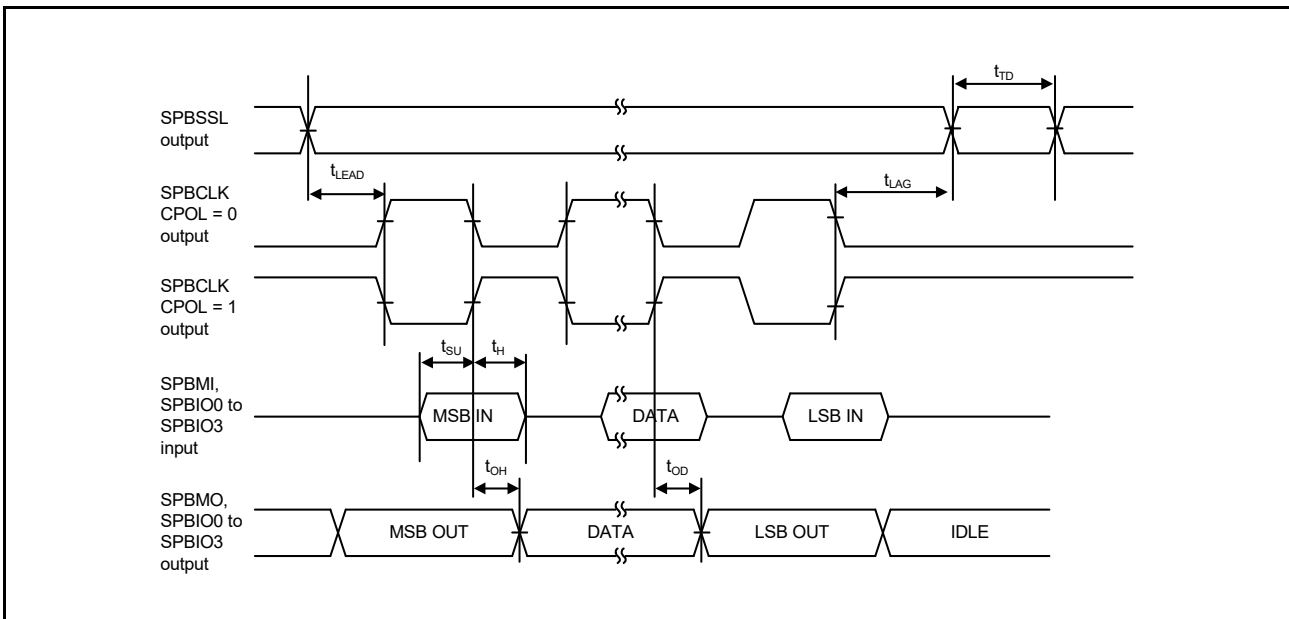

Figure 2.60 SPIBSC Transmit/Receive Timing (CPHAT = 0, CPHAR = 1)

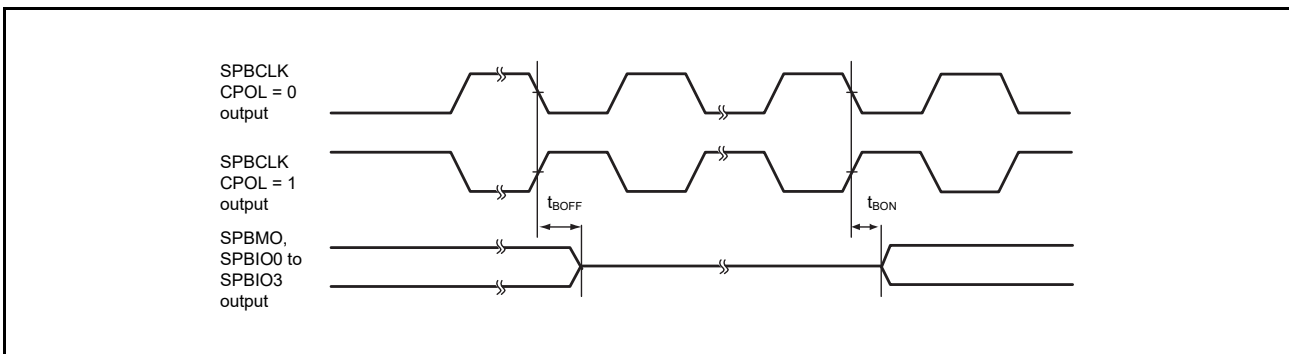

Figure 2.61 SPIBSC Buffer On/Off Timing (CPHAT = 0, CPHAR = 0)

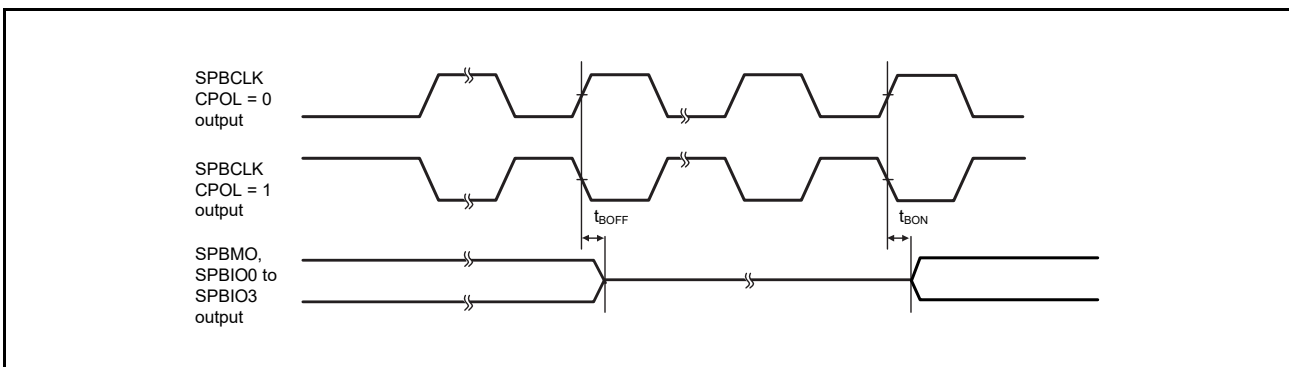

Figure 2.62 SPIBSC Buffer On/Off Timing (CPHAT = 1, CPHAR = 1)

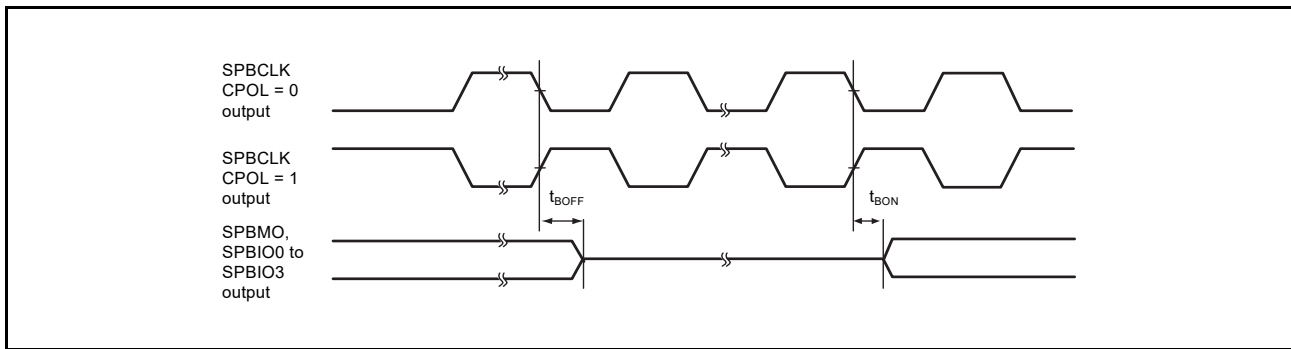

Figure 2.63 SPIBSC Buffer On/Off Timing (CPHAT = 0, CPHAR = 1)

## 2.4.5.11 RIIc Timing

**Table 2.29 RIIc Timing**Output load conditions:  $V_{OL2} = 0.4\text{ V}$ ,  $I_{OL2} = 3\text{ mA}$ 

Item	symbol	min*2	max*2	Unit*1	Test Conditions	
RIIc (Standard-mode)	SCL input cycle time	$t_{SCL}$	$6(12) \times t_{IICcyc} + 1300$	—	ns	Figure 2.64
	SCL input high pulse width	$t_{SCLH}$	$3(6) \times t_{IICcyc} + 300$	—	ns	
	SCL input low pulse width	$t_{SCLL}$	$3(6) \times t_{IICcyc} + 300$	—	ns	
	SCL, SDA input rising time	$t_{sr}$	—	1000	ns	
	SCL, SDA input falling time	$t_{sf}$	—	300	ns	
	SCL, SDA input spike pulse removal time	$t_{SP}$	0	$1(4) \times t_{IICcyc}$	ns	
	SDA input bus free time	$t_{BUF}$	$3(6) \times t_{IICcyc} + 300$	—	ns	
	Start condition input hold time	$t_{STAH}$	$t_{IICcyc} + 300$	—	ns	
	Restart condition input setup time	$t_{STAS}$	1000	—	ns	
	Stop condition input setup time	$t_{STOS}$	1000	—	ns	
	Data input setup time	$t_{SDAS}$	$t_{IICcyc} + 50$	—	ns	
	Data input hold time	$t_{SDAH}$	0	—	ns	
	SCL, SDA capacitive load	$C_b$	—	400	pF	
	RIIc (Fast-mode)	SCL input cycle time	$t_{SCL}$	$6(12) \times t_{IICcyc} + 600$	—	
SCL input high pulse width		$t_{SCLH}$	$3(6) \times t_{IICcyc} + 300$	—	ns	
SCL input low pulse width		$t_{SCLL}$	$3(6) \times t_{IICcyc} + 300$	—	ns	
SCL, SDA input rising time		$t_{sr}$	—*4	300	ns	
SCL, SDA input falling time		$t_{sf}$	—*4	300	ns	
SCL, SDA input spike pulse removal time		$t_{SP}$	0	$1(4) \times t_{IICcyc}$	ns	
SDA input bus free time		$t_{BUF}$	$3(6) \times t_{IICcyc} + 300$	—	ns	
Start condition input hold time		$t_{STAH}$	$t_{IICcyc} + 300$	—	ns	
Restart condition input setup time		$t_{STAS}$	300	—	ns	
Stop condition input setup time		$t_{STOS}$	300	—	ns	
Data input setup time		$t_{SDAS}$	$t_{IICcyc} + 50$	—	ns	
Data input hold time		$t_{SDAH}$	0	—	ns	
SCL, SDA capacitive load*3		$C_b$	—	400	pF	

Note 1.  $t_{IICcyc}$ : RIIc internal reference clock (IIC $\phi$ ) cycle

Note 2. The value out of parentheses is applicable when the value of the ICMR3.NF[1:0] bits is 00b while the digital filter is enabled by setting ICFER.NFE = 1. The value within parentheses is applicable when the value of the ICMR3.NF[1:0] bits is 11b while the digital filter is enabled by setting ICFER.NFE = 1.

Note 3.  $C_b$  is the total capacitance of the bus lines.Note 4. The minimum values are not specified for  $t_{sr}$  and  $t_{sf}$  in Fast-mode.

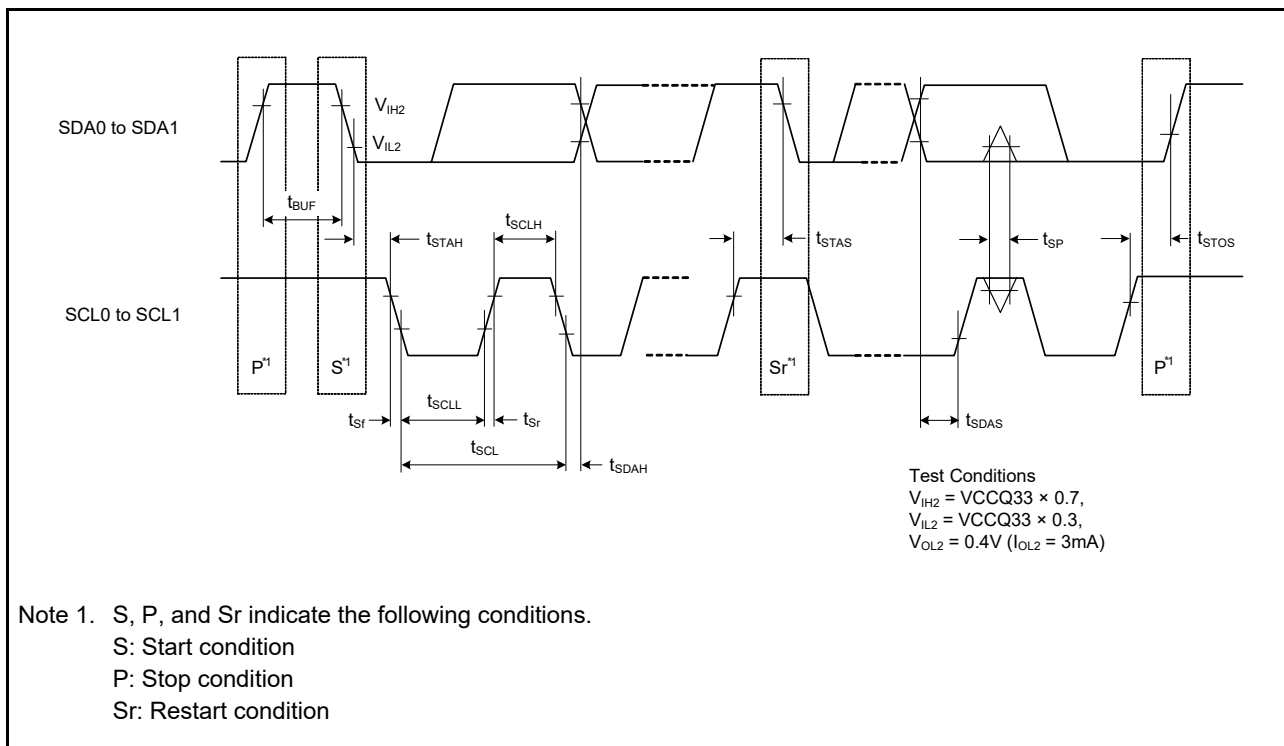
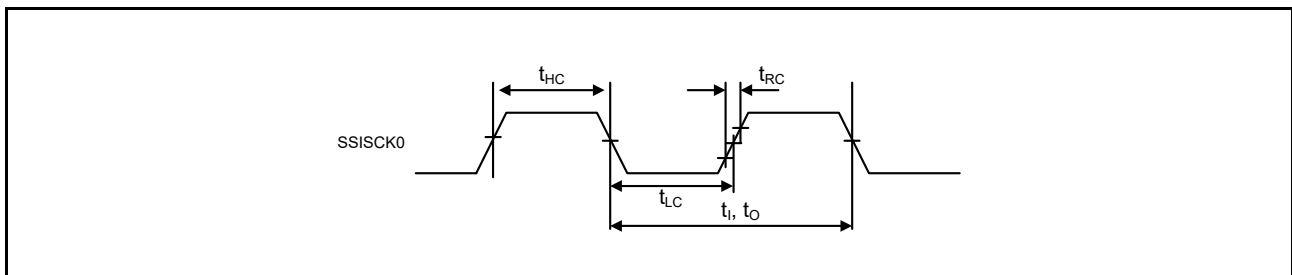
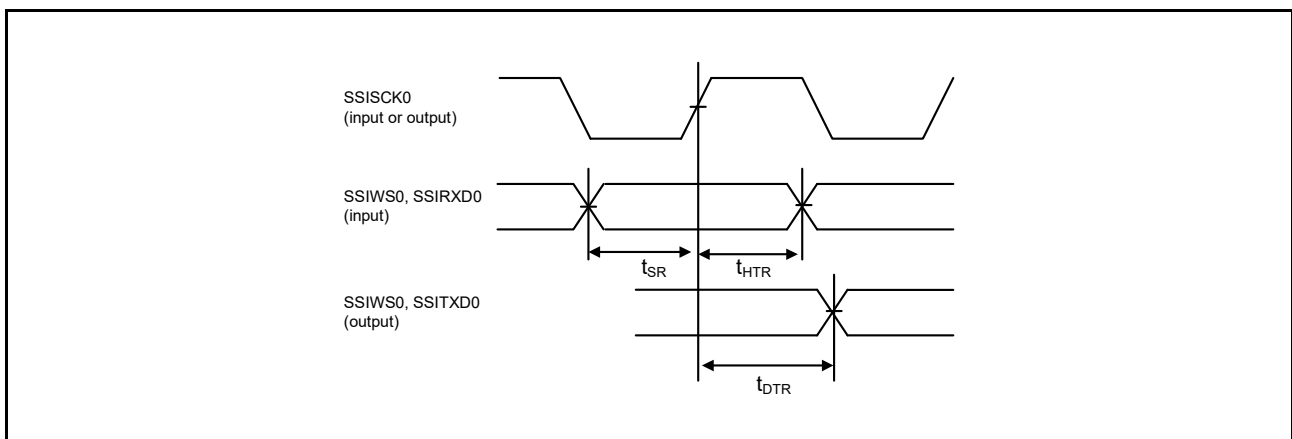

Figure 2.64 IICa Bus Interface Input/Output Timing

## 2.4.5.12 Serial Sound Interface Timing

**Table 2.30 Serial Sound Interface Timing**Output load conditions:  $V_{OH} = V_{CCQ33} \times 0.5$ ,  $V_{OL1} = V_{CCQ33} \times 0.5$ ,  $C = 30$  pF

Item	Symbol	Min.	Max.	Unit	Test Conditions	
SSI	AUDIO_CLK input frequency	$t_{AUDIO}$	1	50	MHz	
	Output clock cycle	$t_O$	150	64000	ns	Figure 2.65
	Input clock cycle	$t_i$	150	64000	ns	
	Clock high level	$t_{HC}$	60	—	ns	
	Clock low level	$t_{LC}$	60	—	ns	
	Clock rising time	$t_{RC}$	—	25	ns	
	Data delay time	$t_{DTR}$	-5	25	ns	Figure 2.66, Figure 2.67
	Setup time	$t_{SR}$	25	—	ns	
	Hold time	$t_{HTR}$	25	—	ns	
	WS change edge SSITXD0 output delay	$T_{DTRW}$	—	25	ns	Figure 2.68

**Figure 2.65 Clock Input/Output Timing****Figure 2.66 Transmit/Receive Timing (SSISCK0 Rising Synchronous)**



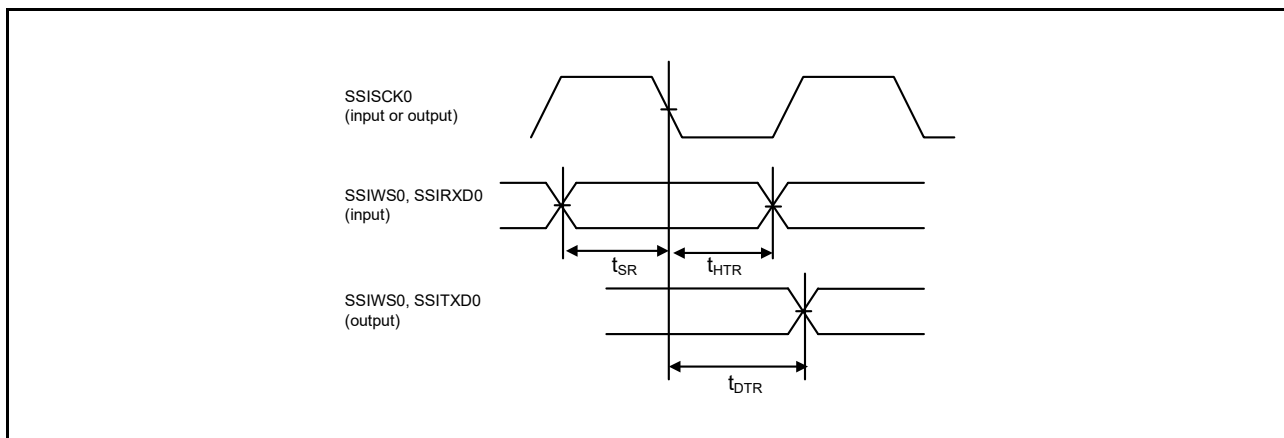

Figure 2.67 Transmit/Receive Timing (SSISCK0 Falling Synchronous)

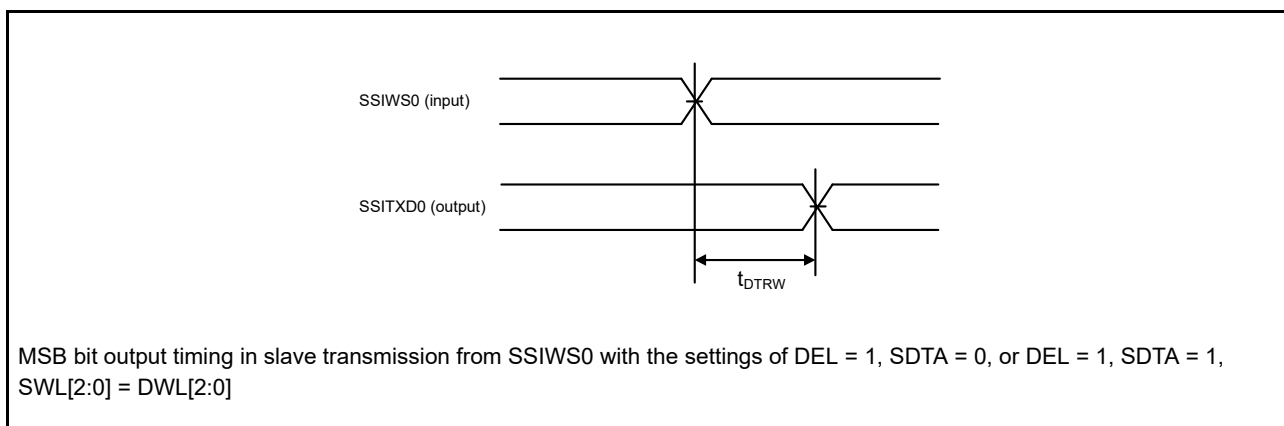

Figure 2.68 SSITXD0 Output Delay from SSIWS0 Change Edge

### 2.4.5.13 CAN Interface Timing

**Table 2.31 CAN Interface Timing**

Item	Symbol	min	max	Unit	Test Conditions
Internal delay time	t <sub>node</sub>	—	100	ns	Figure 2.69
Transmission rate		—	1	Mbps	

Internal delay time (t<sub>node</sub>) = Internal transmission delay time (t<sub>output</sub>) + Internal reception delay time (t<sub>input</sub>)

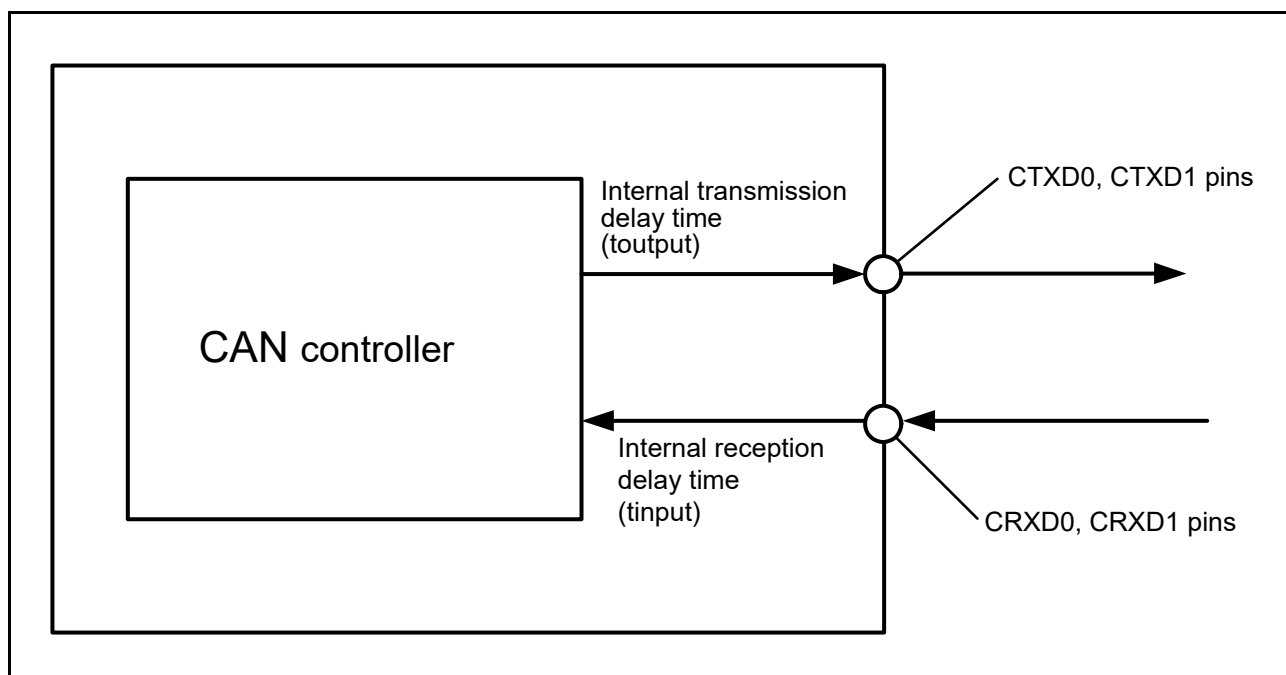

**Figure 2.69 CAN Interface Conditions**

## 2.4.5.14 ETHERC Timing

**Table 2.32 ETHERC Timing**

Output load conditions:  $V_{OH} = 2.0\text{ V}$ ,  $V_{OL1} = 0.8\text{ V}$ ,  $C = 25\text{ pF}$  (RMII)  
 $V_{OH} = VCCQ33 \times 0.5$ ,  $V_{OL1} = VCCQ33 \times 0.5$ ,  $C = 30\text{ pF}$  (MII)

Item	Symbol	min	max	Unit	Test Conditions	
ETHERC (RMII)	CLKOUT25Mn cycle time	$T_{ck}$	20	—	ns	Figure 2.70 to
	ETHn_Txxx*1 output delay time	$T_{co}$	2	16	ns	Figure 2.73
	ETHn_Rxxx*2 setup time	$T_{su}$	4	—	ns	
	ETHn_Rxxx*2 hold time	$T_{hd}$	2	—	ns	
	ETHn_xxxx*1, *2 rising/falling time	$T_r, T_f$	0.5	5	ns	
ETHERC (MII)	ETHn_TXC cycle time	$t_{Tcyc}$	40	—	ns	—
	ETHn_TXEN output delay time	$t_{TENd}$	0	25	ns	Figure 2.74
	ETHn_TXD0 to ETHn_TXD3 output delay time	$t_{MTDd}$	0	25	ns	
	ETHn_TXER output delay time	$t_{TERd}$	—	25	ns	Figure 2.75
	ETHn_RXC cycle time	$t_{TRcyc}$	40	—	ns	—
	ETHn_RXDV setup time	$t_{RDVs}$	10	—	ns	Figure 2.76
	ETHn_RXDV hold time	$t_{RDVh}$	10	—	ns	
	ETHn_RXD0 to ETHn_RXD3 setup time	$t_{MRDs}$	10	—	ns	
	ETHn_RXD0 to ETHn_RXD3 hold time	$t_{MRDh}$	10	—	ns	
	ETHn_RXER setup time	$t_{RErs}$	10	—	ns	Figure 2.77
	ETHn_RXER hold time	$t_{RErh}$	10	—	ns	

Note 1. ETHn\_TXEN, ETHn\_TXD1, ETHn\_TXD0

Note 2. ETHn\_RXDV, ETHn\_RXD1, ETHn\_RXD0, ETHn\_RXER

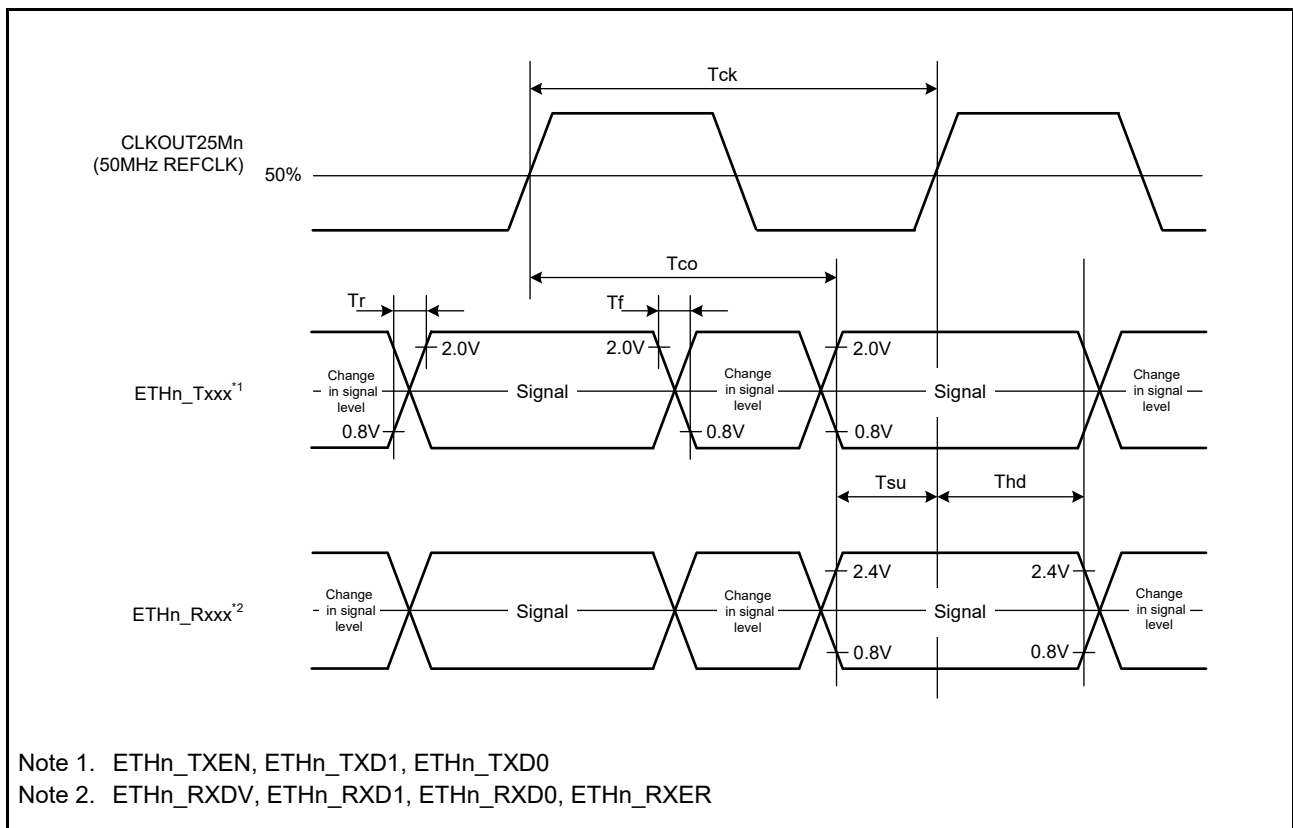
**Figure 2.70 Timing with the CLKOUT25Mn and RMII Signals**

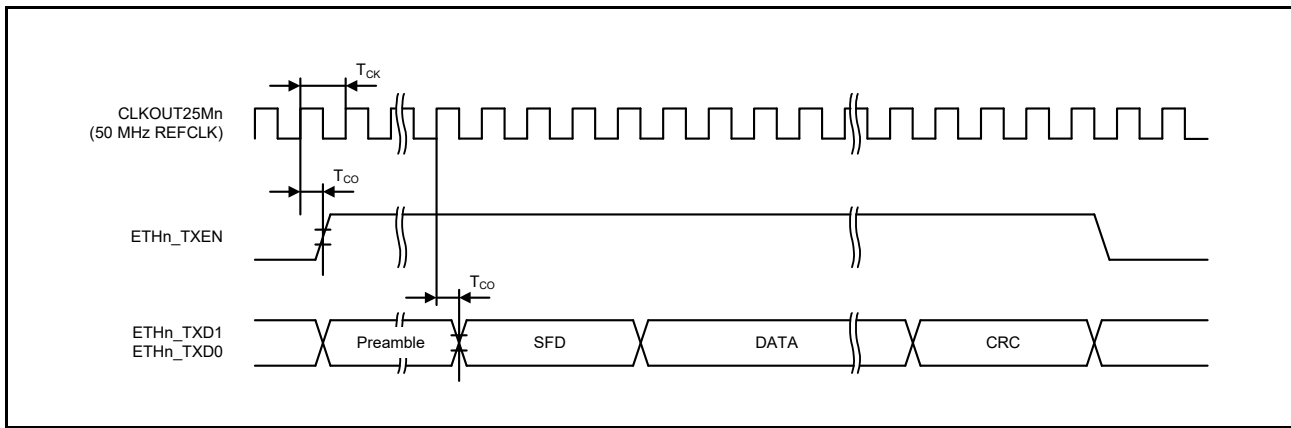

Figure 2.71 RMII Transmission Timing

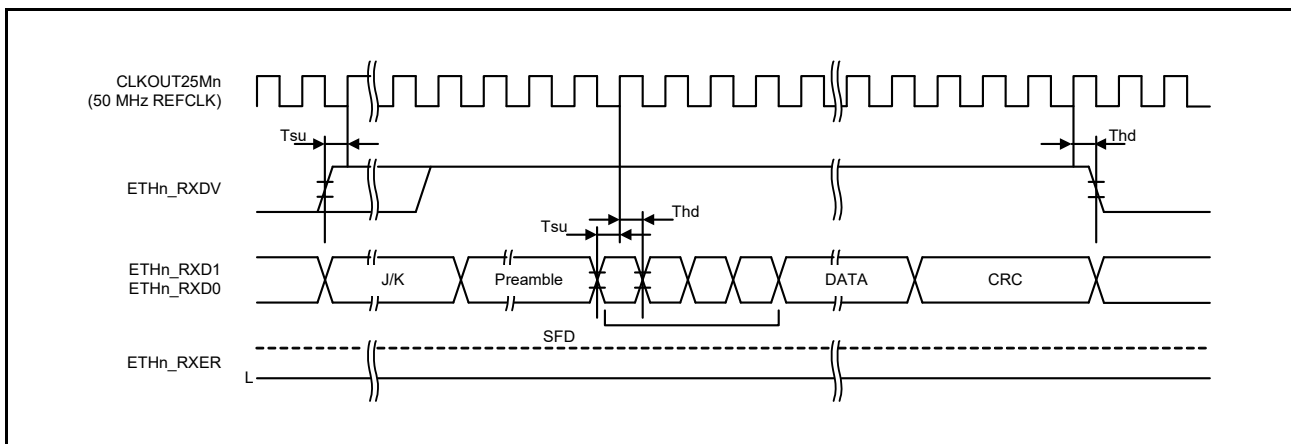

Figure 2.72 RMII Reception Timing (Normal Operation)

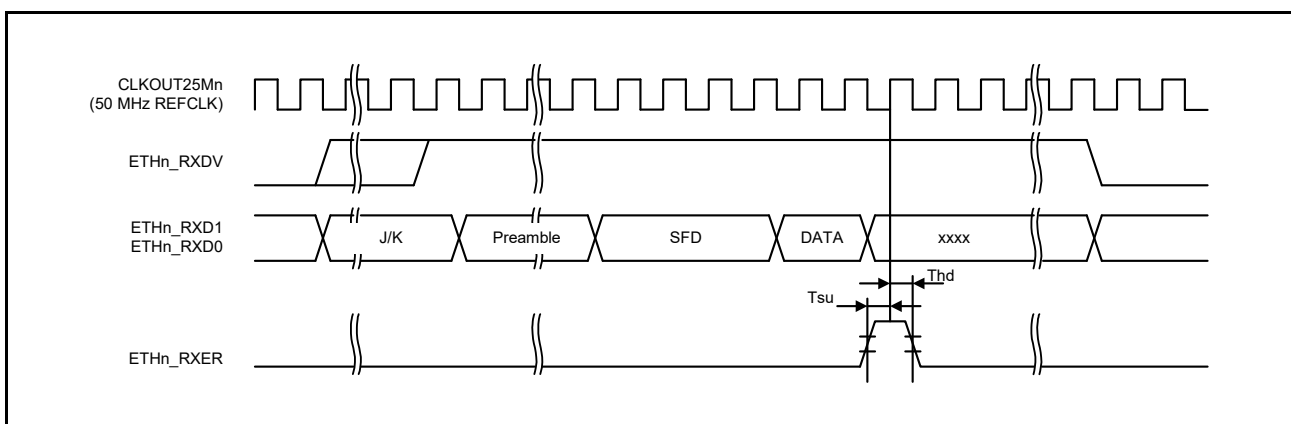

Figure 2.73 RMII Reception Timing (Error Occurrence)

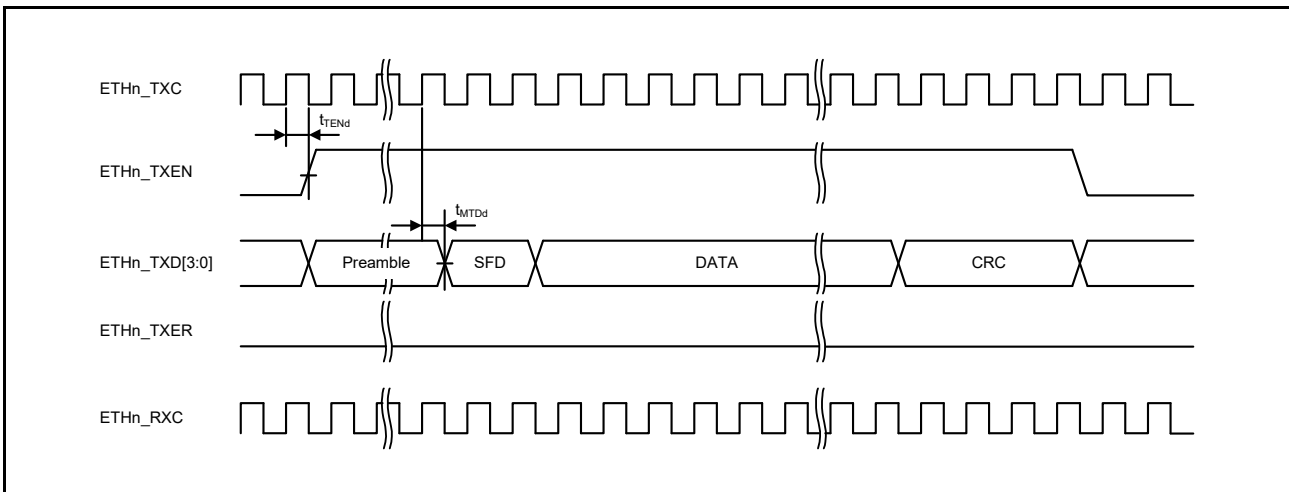

Figure 2.74 MII Transmission Timing

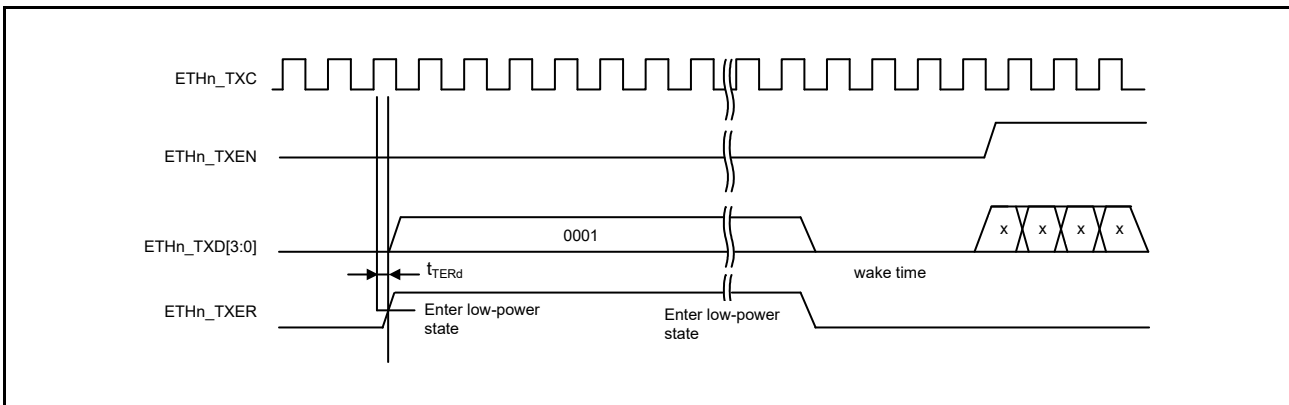

Figure 2.75 MII Transmission Timing

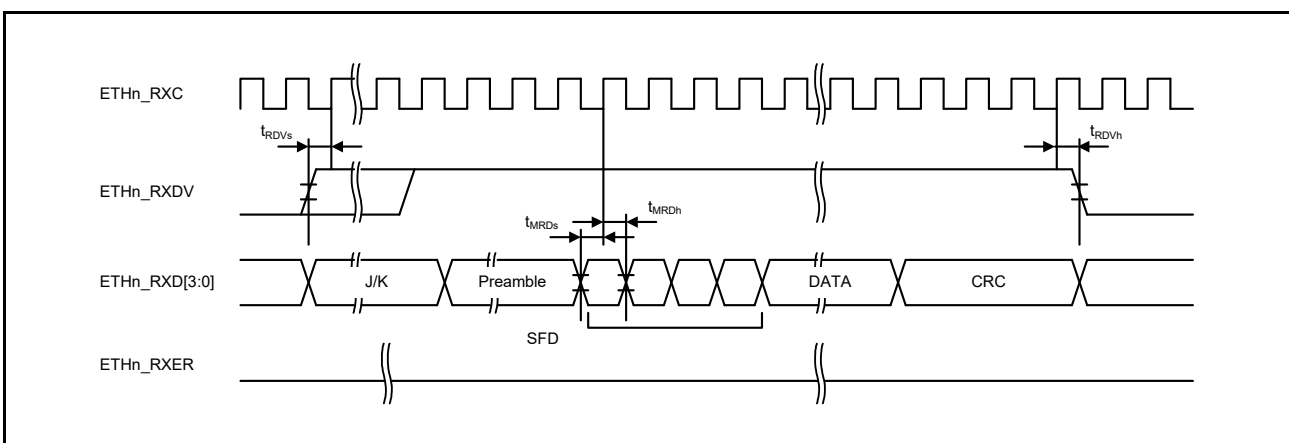

Figure 2.76 MII Reception Timing (Normal Operation)

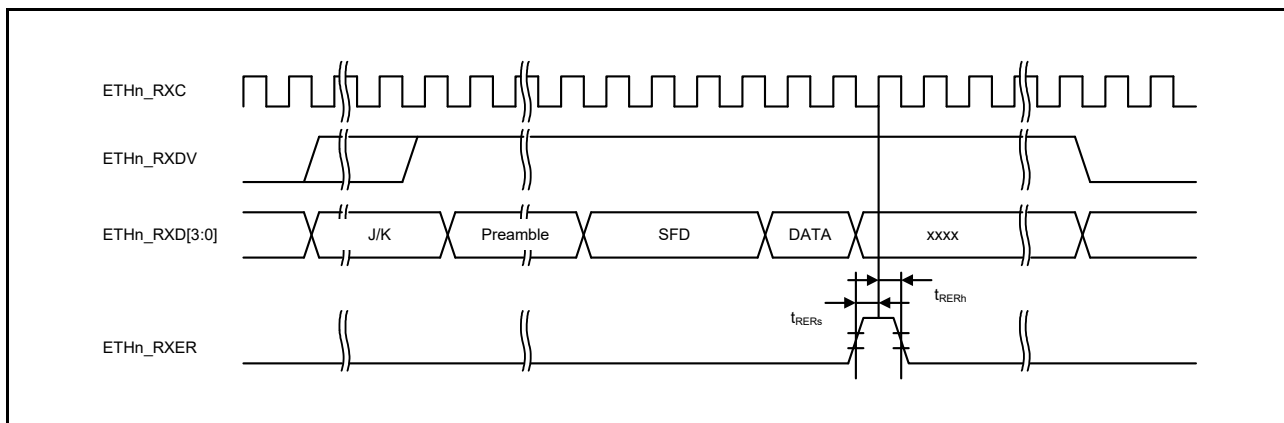

Figure 2.77 MII Reception Timing (Error Occurrence)

### 2.4.5.15 Serial Management Interface Timing

**Table 2.33 Serial Management Interface**

Output load conditions:  $V_{OH} = V_{CCQ33} \times 0.5$ ,  $V_{OL1} = V_{CCQ33} \times 0.5$ ,  $C = 30$  pF

Item	Symbol	min	max	Unit	Test Conditions	
MDIO	ETHn_MDC output cycle	$t_{MDC}$	80	—	ns	Figure 2.78
	ETHn_MDIO input setting time (to ETHn_MDC↑)	$t_{SMDIO}$	10	—	ns	
	ETHn_MDIO input hold time (to ETHn_MDC↑)	$t_{HMDIO}$	0	—	ns	
	ETHn_MDIO output delay time (to ETHn_MDC↓)	$t_{DMDIO}$	—	20	ns	

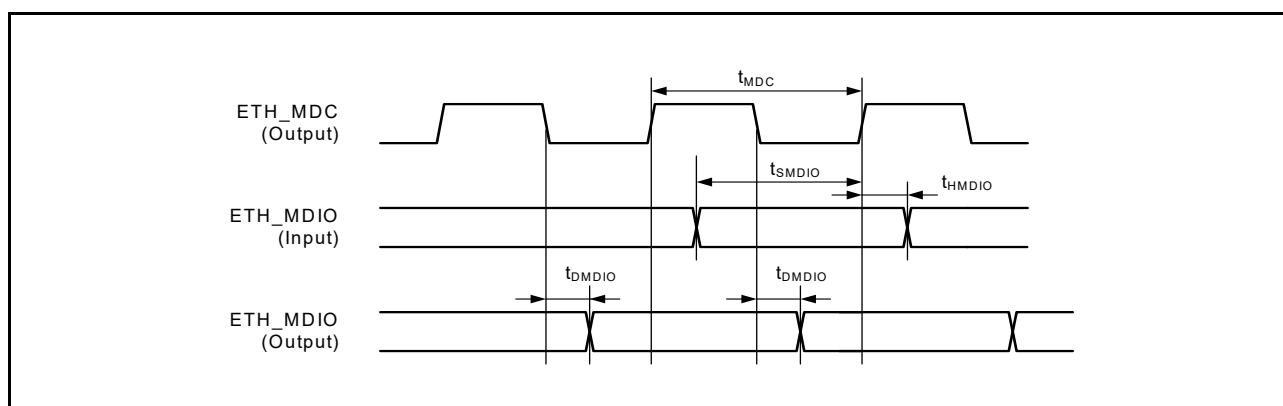
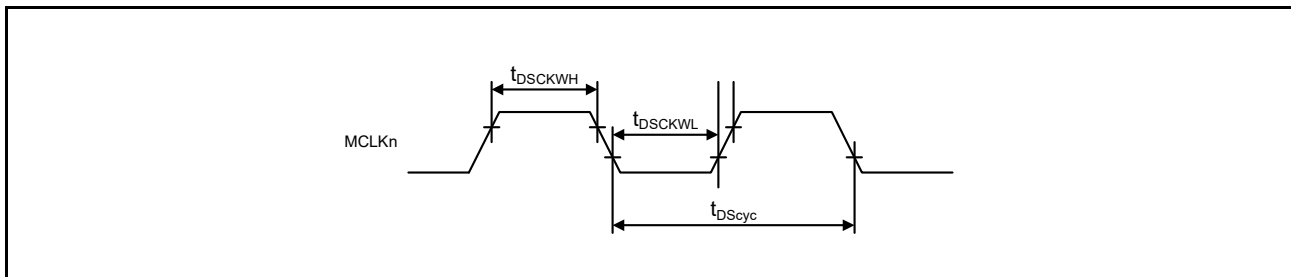
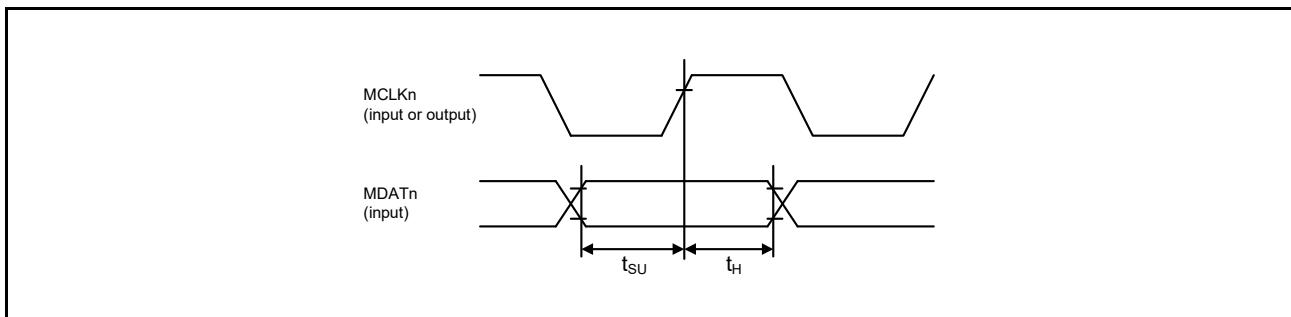

**Figure 2.78 Serial Management Access Timing**

## 2.4.5.16 Delta-Sigma Interface Timing

**Table 2.34**  $\Delta\Sigma$  Interface TimingConditions:  $V_{OH} = V_{CCQ33} \times 0.5$ ,  $V_{OL1} = V_{CCQ33} \times 0.5$ ,  $C = 30$  pF

Item		Symbol	min	max	Unit	Test Conditions	
DSMIF	Clock cycle	Master	$t_{DS\text{cyc}}$	1	1	$t_{DC\text{cyc}}$	Figure 2.79
		Slave		40	200	ns	
	Clock high level	Master	$t_{DS\text{CKWH}}$	16	—	ns	
		Slave		16	—	ns	
	Clock low level	Master	$t_{DS\text{CKWL}}$	16	—	ns	
		Slave		16	—	ns	
Setup time	Master	$t_{SU}$	15	—	ns	Figure 2.80, Figure 2.81	
	Slave		10	—	ns		
Hold time	Master	$t_H$	0	—	ns		
	Slave		10	—	ns		

Note:  $t_{DC\text{cyc}}$ : One cycle time of the  $\Delta\Sigma$  interface clock (DSCLK0, DSCLK1)**Figure 2.79** Clock Input/Output Timing**Figure 2.80** Reception Timing (MCLKn Rising Synchronous)



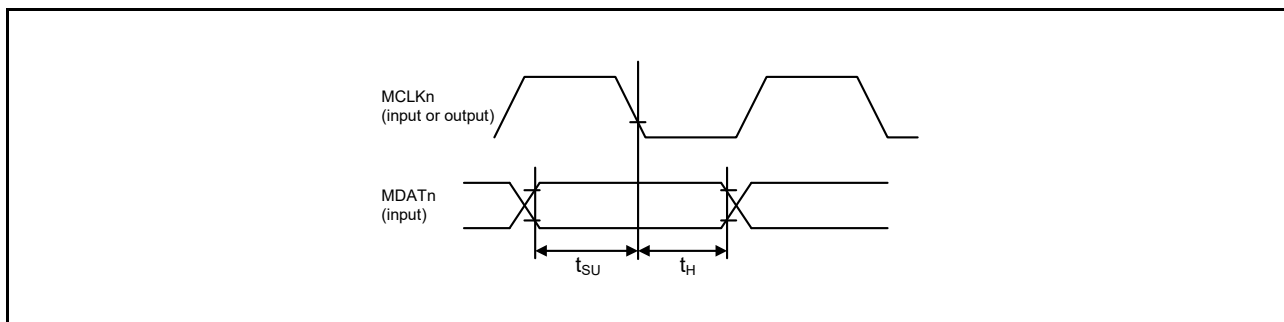

Figure 2.81 Reception Timing (MCLKn Falling Synchronous)

## 2.5 USB Characteristics

- Conditions:  $VDD = PLLVDD0 = PLLVDD1 = DVDD\_USB = 1.14$  to  $1.26$  V,  
 $VCCQ33 = AVCC0 = AVCC1 = VREFH0 = VREFH1 = VDD33\_USB = 3.0$  to  $3.6$  V  
 $VSS = PLLVSS0 = PLLVSS1 = AVSS0 = AVSS1 = VREFL0 = VREFL1 = VSS\_USB = 0$  V,  
 $T_j = -40$  to  $125$  °C

Note: The 176-pin HLQFP does not have pins AVCC1, AVSS1, VREFH1, and VREFL1.

**Table 2.35 On-chip USB Full-Speed Characteristics (USB\_DP, USB\_DM Pin Characteristics)**

Item	Symbol	min	typ	max	Unit	Test Conditions
Rising time	$t_{FR}$	4	—	20	ns	Figure 2.82
Falling time	$t_{FF}$	4	—	20	ns	
Rising/falling time ratio	$t_{FR} / t_{FF}$	90	—	111.11	%	$t_{FR} / t_{FF}$

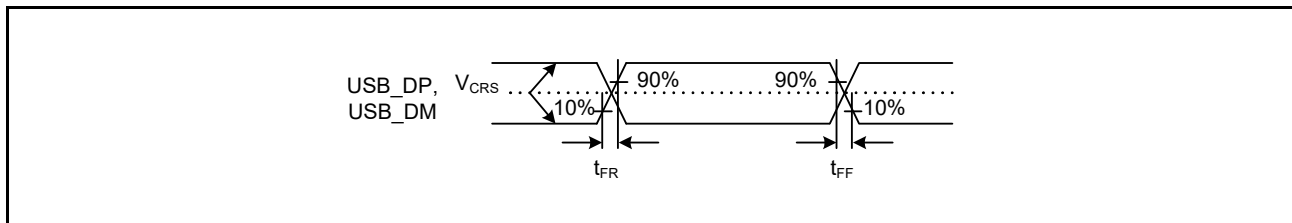

**Figure 2.82 USB\_DP, USB\_DM Output Timing (Full Speed)**

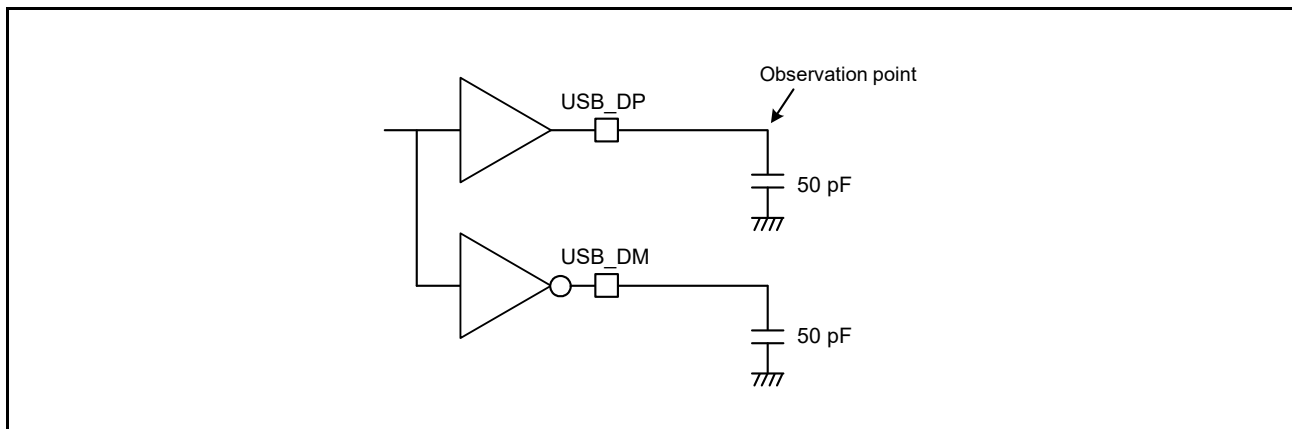

**Figure 2.83 Measurement Circuit (Full Speed)**

**Table 2.36 On-chip USB High-Speed Characteristics (USB\_DP, USB\_DM Pin Characteristics)**

Item		Symbol	min	Typ	max	Unit	Test Conditions
AC characteristics	Rising time	$t_{HSR}$	500	—	—	ps	Figure 2.84
	Falling time	$t_{HSF}$	500	—	—	ps	
	Output resistance	$Z_{HSDRV}$	40.5	—	49.5	$\Omega$	

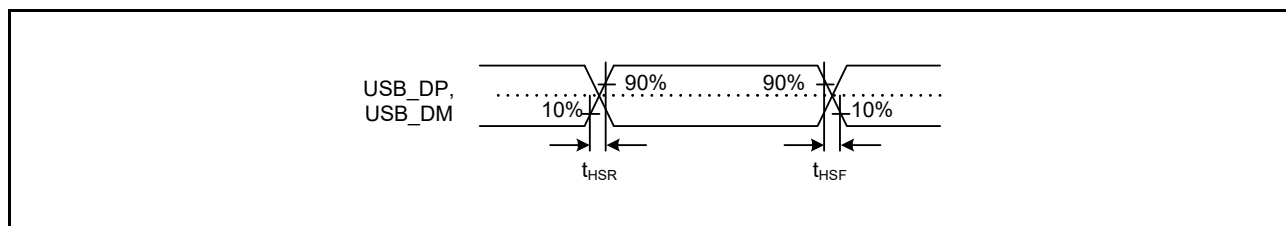

**Figure 2.84 USB\_DP, USB\_DM Output Timing (High Speed)**

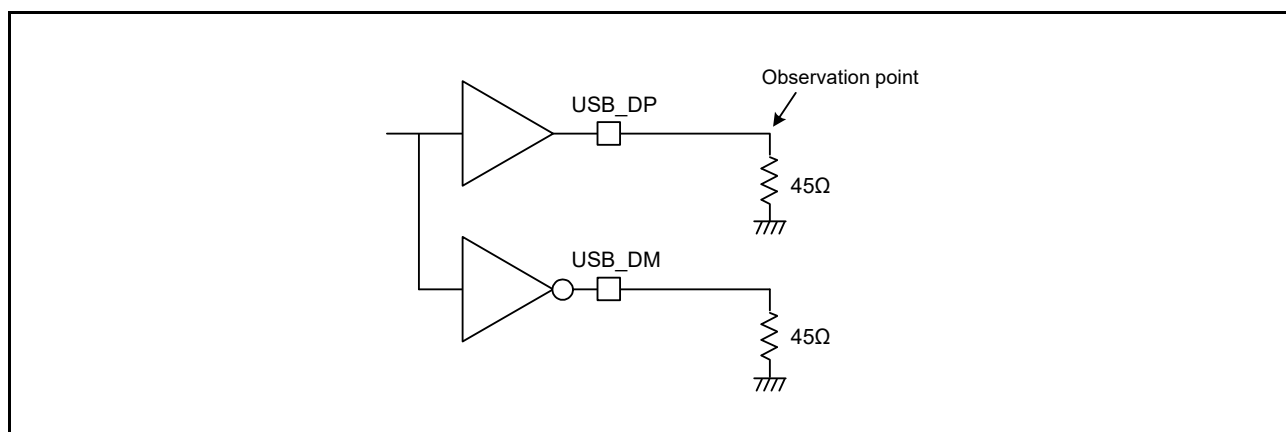

**Figure 2.85 Measurement Circuit (High Speed)**

## 2.6 A/D Conversion Characteristics

- Conditions: VDD = PLLVDD0 = PLLVDD1 = DVDD\_USB = 1.14 to 1.26 V,  
VCCQ33 = AVCC0 = AVCC1 = VREFH0 = VREFH1 = VDD33\_USB = 3.0 to 3.6 V  
VSS = PLLVSS0 = PLLVSS1 = AVSS0 = AVSS1 = VREFL0 = VREFL1 = VSS\_USB = 0 V,  
Tj = -40 to 125 °C

Note: The 176-pin HLQFP does not have pins AVCC1, AVSS1, VREFH1, and VREFL1.

**Table 2.37 12-Bit A/D (Unit 0) Conversion Characteristics**

Item		min	typ	max	Unit	Test Conditions
Resolution		8	—	12	Bit	
Analog input capacitance		—	—	30	pF	
Channel-dedicated sample-and-hold circuits in use (AN000 to AN003)	Conversion time*1 (Operation at PCLKF = 60 MHz) Permissible signal source impedance Max. = 1.0 kΩ	1.2 (0.4 + 0.4) *2	—	3.6	μs	<ul style="list-style-type: none"> <li>Sampling of channel-dedicated sample-and-hold circuits in 24 states</li> <li>Sampling in 24 states</li> </ul>
When disconnection detection assistance is in use	Offset error	—	—	±7.5	LSB	
	Full-scale error	—	—	±7.5	LSB	
	Quantization error	—	±0.5	—	LSB	
	Absolute accuracy	—	—	±7.5	LSB	
	DNL differential nonlinearity error	—	—	±3.0	LSB	
	INL integral nonlinearity error	—	—	±4.0	LSB	
	Holding characteristics of sample-and-hold circuits	—	—	3.2	μs	Self-diagnosis + 4-channel simultaneous sampling
Dynamic range	0.25	—	VREFH0 – 0.25	V		
Channel-dedicated sample-and-hold circuits in use (AN000 to AN003)	Conversion time*1 (Operation at PCLKF = 60 MHz) Permissible signal source impedance Max. = 1.0 kΩ	1.2 (0.4 + 0.4) *2	—	3.6	μs	<ul style="list-style-type: none"> <li>Sampling of channel-dedicated sample-and-hold circuits in 24 states</li> <li>Sampling in 24 states</li> </ul>
When disconnection detection assistance is not in use	Offset error	—	—	±6.5	LSB	
	Full-scale error	—	—	±6.5	LSB	
	Quantization error	—	±0.5	—	LSB	
	Absolute accuracy	—	—	±6.5	LSB	
	DNL differential nonlinearity error	—	—	±3.0	LSB	
	INL integral nonlinearity error	—	—	±4.0	LSB	
	Holding characteristics of sample-and-hold circuits	—	—	3.2	μs	Self-diagnosis + 4-channel simultaneous sampling
Dynamic range	0.25	—	VREFH0 – 0.25	V		
Channel-dedicated sample-and-hold circuits not in use (AN000 to AN007)	Conversion time*1 (Operation at PCLKF = 60 MHz) Permissible signal source impedance Max. = 1.0 kΩ	0.483 (0.267)*2	—	—	μs	Sampling in 16 states
	Offset error	—	—	±5.0	LSB	
	Full-scale error	—	—	±5.0	LSB	
	Quantization error	—	±0.5	—	LSB	
	Absolute accuracy	—	—	±6.0	LSB	
	DNL differential nonlinearity error	—	—	±2.5	LSB	
	INL integral nonlinearity error	—	—	±3.0	LSB	

Note: The above specified values apply when there is no access to the external bus during A/D conversion. If access proceeds during A/D conversion, values may not fall within the above ranges.

Note 1. The conversion time is the total of the sampling time and the comparison time ( $t_{SPLSH} + t_{CONV}$  in Figure 43.31 and Figure 43.32 in section 43, 12-Bit A/D Converter (S12ADCa), in the RZ/T1 Group User's Manual: Hardware). The number of sampling states is indicated for each item in Test Conditions.

Note 2. The value in parentheses indicates the sampling time.

**Table 2.38 12-Bit A/D (Unit 1) Conversion Characteristics**

Item		min	typ	max	Unit	Test Conditions
Resolution		8	—	12	Bit	
Conversion time*1 (Operation at PCLKF = 60 MHz)	Permissible signal source impedance Max. = 1.0 kΩ	0.883 (0.667)*2	—	—	μs	Sampling in 40 states
Analog input capacitance		—	—	30	pF	
Offset error		—	—	±6.0	LSB	
Full-scale error		—	—	±6.0	LSB	
Quantization error		—	±0.5	—	LSB	
Absolute accuracy		—	—	±6.0	LSB	
DNL differential nonlinearity error		—	—	±3.0	LSB	
INL integral nonlinearity error		—	—	±4.0	LSB	

Note: The above specified values apply when there is no access to the external bus during A/D conversion. If access proceeds during A/D conversion, values may not fall within the above ranges.

Note 1. The conversion time is the total of the sampling time and the comparison time ( $t_{SPLSH} + t_{CONV}$  in Figure 43.31 and Figure 43.32 in section 43, 12-Bit A/D Converter (S12ADCa), in the RZ/T1 Group User's Manual: Hardware). The number of sampling states is indicated for each item in Test Conditions.

Note 2. The value in parentheses indicates the sampling time.

## 2.7 Temperature Sensor Characteristics

- Conditions: VDD = PLLVDD0 = PLLVDD1 = DVDD\_USB = 1.14 to 1.26 V,  
VCCQ33 = AVCC0 = AVCC1 = VREFH0 = VREFH1 = VDD33\_USB = 3.0 to 3.6 V  
VSS = PLLVSS0 = PLLVSS1 = AVSS0 = AVSS1 = VREFL0 = VREFL1 = VSS\_USB = 0 V,  
Tj = -40 to 125 °C

Note: The 176-pin HLQFP does not have pins AVCC1, AVSS1, VREFH1, and VREFL1.

**Table 2.39 Temperature Sensor Characteristics**

Item	min	typ	max	Unit	Test Conditions
Relative accuracy	—	±1	—	°C	
Temperature slope	—	4.1	—	mV/°C	
Output voltage (at 25°C)	—	1.21	—	V	
Temperature sensor start time	—	—	30	μs	
Sampling time	4.25	—	—	μs	ADSSTR.SST[7:0] = 255 states (when PCLKF [ADC (unit0) sampling CLK] = 60 MHz)

## 2.8 Oscillation Stop Detection Timing

**Table 2.40 Oscillation Stop Detection Circuit Characteristics**

Item	Symbol	min	typ	max	Unit	Test Conditions
Clock switching time	$t_{dr}$	—	—	1	ms	Figure 2.86

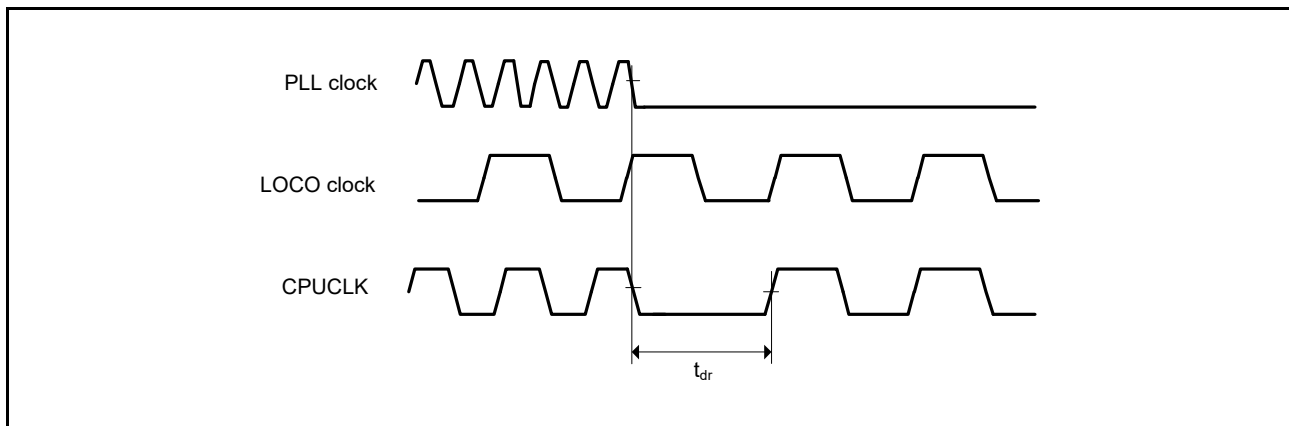

**Figure 2.86 Oscillation Stop Detection Timing**

## 2.9 Debug Interface Timing

**Table 2.41 Debug Interface Timing**

Output load conditions:  $V_{OH} = V_{CCQ33} - 0.5\text{ V}$ ,  $V_{OL1} = 0.4\text{ V}$

Item	Symbol	Min.	Max.	Unit	Reference Figure
TCK cycle time	$t_{TCKcyc}$	30	—	ns	Figure 2.87
TCK high pulse width	$t_{TCKH}$	0.4	0.6	$t_{TCKcyc}$	
TCK low pulse width	$t_{TCKL}$	0.4	0.6	$t_{TCKcyc}$	
TDI setup time	$t_{TDIS}$	5	—	ns	Figure 2.88
TDI hold time	$t_{TDIH}$	5	—	ns	Output load: 30 pF
TMS/SWDIO setup time	$t_{TMSS}$	5	—	ns	
TMS/SWDIO hold time	$t_{TMSh}$	5	—	ns	
SWDIO delay time	$t_{SWDO}$	—	15	ns	
TDO delay time	$t_{TDOD}$	—	15	ns	
Capture register setup time	$t_{CAPTS}$	5	—	ns	Figure 2.89
Capture register hold time	$t_{CAPTH}$	5	—	ns	
Update register delay time	$t_{UPDATED}$	—	15	ns	
Trace clock cycle	$t_{TCYC}$	26.6	—	ns	Figure 2.90
Trace data delay time	$t_{TDT}$	$0.25 \times t_{TCYC} - 2$	$0.25 \times t_{TCYC} + 2$	ns	Output load: 15 pF

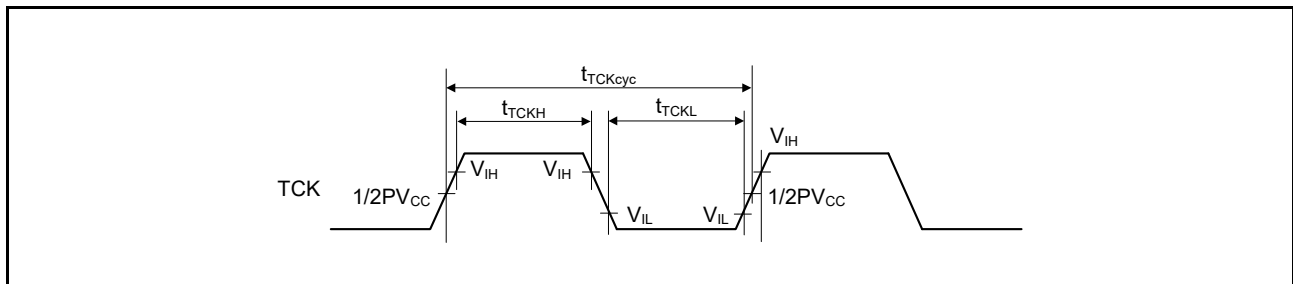

**Figure 2.87 TCK Input Timing**

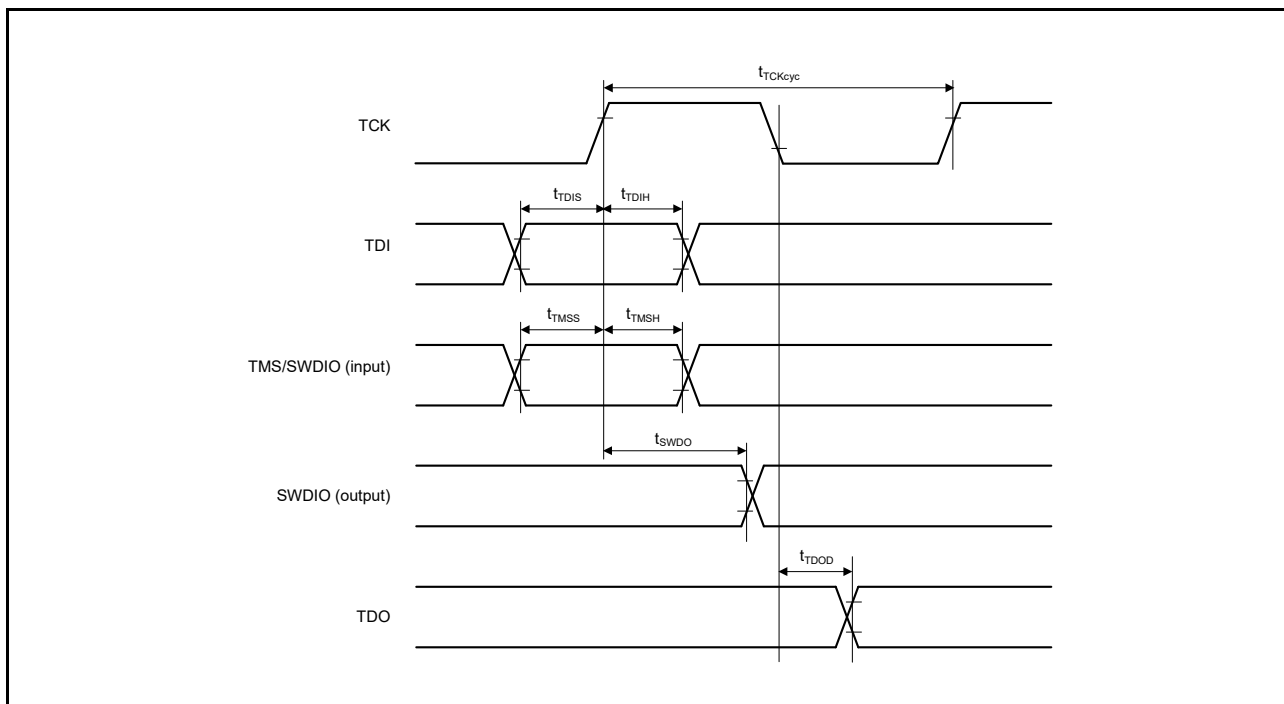

Figure 2.88 Data Transfer Timing

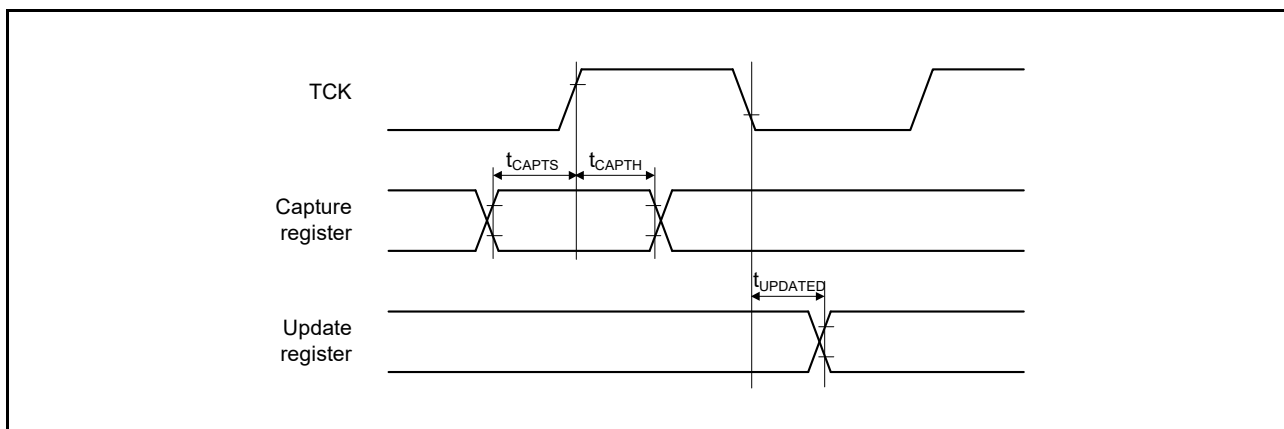

Figure 2.89 Boundary Scan Input/Output Timing



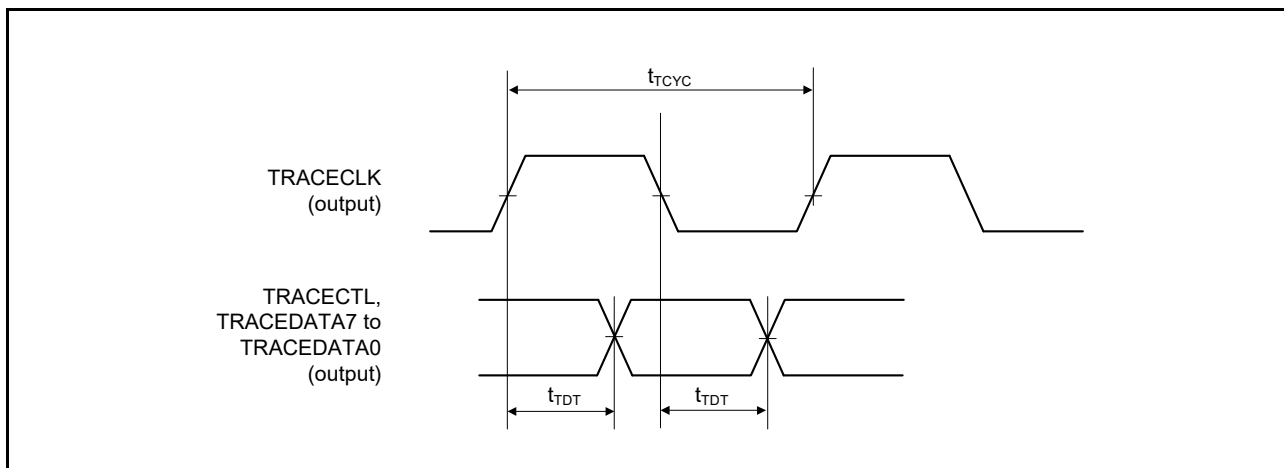

Figure 2.90 Trace Interface Timing

REVISION HISTORY		RZ/T1 Group Datasheet	
Rev.	Date	Description	
		Page	Summary
0.60	Nov. 14, 2014	—	First edition, issued
0.70	Dec. 25, 2014	Features	
		1	■ Operating temperature range: Heading title and description corrected
		Section 1 Overview	
		11	Table 1.3 List of Products (2 / 2): Note corrected
		21	Figure 1.3 Pin Arrangement (176-pin HLQFP): The names of pins 33, 34, 38, 39, and 91, corrected
		26	Table 1.5 Pin Assignments (320-Pin FBGA) (5 / 8): The names of pins M20 and P19, corrected
		27	Table 1.5 Pin Assignments (320-Pin FBGA) (6 / 8): The names of pins R14, R19, R20, T9, V7, and V8, corrected
		29	Table 1.5 Pin Assignments (320-Pin FBGA) (8 / 8): The names of pins Y16 and Y17, corrected
		30	Table 1.6 Pin Assignments (176-Pin HLQFP) (1 / 4): The names of pins 33, 34, 38, and 39, corrected
		31	Table 1.6 Pin Assignments (176-Pin HLQFP) (2 / 4): The names of pins 58, 59, 60, 79, 82, and 83, corrected
		32	Table 1.6 Pin Assignments (176-Pin HLQFP) (3 / 4): The names of pins 91 and 110, corrected
		33	Table 1.6 Pin Assignments (176-Pin HLQFP) (4 / 4): The names of pins 136, 153, 154, 155, 156, and 157, corrected
		39	Table 1.7 List of Pin and Pin Functions (320-Pin FBGA) (6 / 10): The name of pin M20, corrected
		40	Table 1.7 List of Pin and Pin Functions (320-Pin FBGA) (7 / 10): The names of pins P19, R8, and R14, corrected
		41	Table 1.7 List of Pin and Pin Functions (320-Pin FBGA) (8 / 10): The names of pins R19, R20, T9, V7, and V8, corrected
42	Table 1.7 List of Pin and Pin Functions (320-Pin FBGA) (9 / 10): The names of pins Y16 and Y17, corrected		
1.10	Jul. 08, 2016	Feature	
		1	Wholly amended
		1. Overview	
		2 to 49	Wholly amended
		2. Electrical Characteristics	
		50 to 129	Newly added
1.20	Mar. 02, 2017	1. Overview	
		9	Table 1.2 Comparison of Functions for Different Packages: Functions of ETHERC and ECATC, modified. Note 1 added.
		12	Figure 1.1 Block Diagram: Functional blocks of ECATC and ETHERC, modified. Note 1 modified.
		20	Figure 1.2 Pin Arrangement (320-Pin FBGA) (Top View): Pin ERROROUT#, modified
		2. Electrical Characteristics	
		53	Table 2.3 DC Characteristics (2) [Power Supply] Test conditions, modified: Product part no. added
		55	Table 2.4 DC Characteristics (3) [Except for USB2.0 Host/Function-Related Pins] Item modified: "Input pull-up MOS current and resistance" and "Input pull-down MOS current and resistance" R <sub>pu1</sub> , R <sub>pu2</sub> , R <sub>pd1</sub> , and R <sub>pd2</sub> were added. Test conditions for "Input pull-down MOS current and resistance" were modified.
58	Table 2.10 Operating Frequency: Notes 1 to 3, added. The max. value of the CPU clock (CPUCLK), modified.		

Rev.	Date	Description	
		Page	Summary
1.30	Apr. 25, 2017	1. Overview	
		49	Table 1.8 List of Pin and Pin Functions (176-Pin HLQFP) (6/6): The communication function of pin 171, modified
		2. Electrical Characteristics	
		107	Figure 2.60 SPIBSC Transmit/Receive Timing (CPHAT = 0, CPHAR = 1): Modified
1.40	Nov. 15, 2017	All	Cortex-R4F changed to Cortex-R4
		Features	
		1	<ul style="list-style-type: none"> <li>■ Encoder interfaces, changed</li> <li>■ Various communications interfaces: Features of Ethernet changed</li> </ul>
		1. Overview	
		2	1.1 Outline of Specifications: "Cortex®-R4F processor" changed to "Cortex®-R4 processor with FPU"
		8	Table 1.1 Outline of Specifications (7 / 7): Description of the encoder interfaces changed
		16	Table 1.4 Pin Functions (4 / 7): CTS0# to CTS4#: I/O and functional description changed; RTS0# to RTS4#: Functional description changed
		19	Table 1.4 Pin Functions (7 / 7): ENCIF07 to ENCIF12 changed to ENCIF00 to ENCIF12
		22	Table 1.5 Pin Assignments (320-Pin FBGA) (1 / 8): ENCIF12 added to B19; ENCIF11 added to B20
		23	Table 1.5 Pin Assignments (320-Pin FBGA) (2 / 8): ENCIF10 added to C19; ENCIF09 added to D19; ENCIF08 added to E19
		24	Table 1.5 Pin Assignments (320-Pin FBGA) (3 / 8): ENCIF11 added to H19; ENCIF12 added to H20
		25	Table 1.5 Pin Assignments (320-Pin FBGA) (4 / 8): ENCIF10 added to J19
		26	Table 1.5 Pin Assignments (320-Pin FBGA) (5 / 8): ENCIF09 added to N20; ENCIF08 added to P20
		27	Table 1.5 Pin Assignments (320-Pin FBGA) (6 / 8): ENCIF09 added to U3
		28	Table 1.5 Pin Assignments (320-Pin FBGA) (7 / 8): ENCIF10 added to W3; ENCIF11 added to W4; ENCIF08 added to W10; ENCIF12 added to Y4
		35	Table 1.7 List of Pin and Pin Functions (320-Pin FBGA) (2 / 10): ENCIF12 added to B19 under "Others"; ENCIF11 added to B20 under "Others"
		36	Table 1.7 List of Pin and Pin Functions (320-Pin FBGA) (3 / 10): ENCIF10 added to C19 under "Others"; ENCIF09 added to D19 under "Others"; ENCIF08 added to E19 under "Others"
		38	Table 1.7 List of Pin and Pin Functions (320-Pin FBGA) (5 / 10): ENCIF11 added to H19 under "Others"; ENCIF12 added to H20 under "Others"; ENCIF10 added to J19 under "Others"
		40	Table 1.7 List of Pin and Pin Functions (320-Pin FBGA) (7 / 10): ENCIF09 added to N20 under "Others"; ENCIF08 added to P20 under "Others"
		41	Table 1.7 List of Pin and Pin Functions (320-Pin FBGA) (8 / 10): ENCIF09 added to U3 under "Others"
		42	Table 1.7 List of Pin and Pin Functions (320-Pin FBGA) (9 / 10): ENCIF10 added to W3 under "Others"; ENCIF11 added to W4 under "Others"; ENCIF08 added to W10 under "Others"; ENCIF12 added to Y4
		2. Electrical Characteristics	
		65, 66	Table 2.17 Bus Timing: "CKIO = 75MHz" changed to "CKIO = 1/tCKcyc"; "tcyc" changed to "tCKcyc"; entries for "Address delay time 1", "CS# delay time 1", "Read/write delay time 1", "Read data setup time 1 to 3" and "WAIT# setup time" changed; Notes 1, 3, and 4 changed
		102	Table 2.27 RSPIa Timing: Note 2 changed (SSLND → SPCKD); Note 3 added
		111	Figure 2.64 IICa Bus Interface Input/Output Timing: SDA0 to SDA3 and SCL0 to SCL3 deleted

Rev.	Date	Description	
		Page	Summary
1.40	Jan. 19, 2018	All	Cortex-R4F changed to Cortex-R4
			Terms corrected (Ether Switch → Ethernet switch; Ether Mac → Ethernet Mac; Ether PHY → Ethernet PHY; Ether clock(s) → Ethernet clock(s); receive buffer(s) → reception buffer(s); transmit buffer(s) → transmission buffer(s); transmit/receive buffer(s) → transmission/reception buffer(s); transmit mode → transmission mode; receive mode → reception mode; compare match counter (CMCNT) → compare match timer counter (CMCNT); compare match constant register (CMCOR) → compare match timer constant register (CMCOR); low active → active low; high active → active high; valley → trough)
			Features
		1	<ul style="list-style-type: none"> <li>■ Encoder interfaces, changed</li> <li>■ Various communications interfaces: Features of Ethernet changed</li> </ul>
			1. Overview
		2	1.1 Outline of Specifications: "Cortex®-R4F processor" changed to "Cortex®-R4 processor with FPU"
		2	Table 1.1 Outline of Specifications (1 / 7): Registered trademark symbol added to "Thumb"; description of "Clock" changed
		8	Table 1.1 Outline of Specifications (7 / 7): Description of the encoder interfaces changed
		16	Table 1.4 Pin Functions (4 / 7): CTS0# to CTS4#: I/O and functional description changed; RTS0# to RTS4#: Functional description changed
		19	Table 1.4 Pin Functions (7 / 7): ENCIF07 to ENCIF12 changed to ENCIF00 to ENCIF12
		22	Table 1.5 Pin Assignments (320-Pin FBGA) (1 / 8): ENCIF12 added to B19; ENCIF11 added to B20
		23	Table 1.5 Pin Assignments (320-Pin FBGA) (2 / 8): ENCIF10 added to C19; ENCIF09 added to D19; ENCIF08 added to E19
		24	Table 1.5 Pin Assignments (320-Pin FBGA) (3 / 8): ENCIF11 added to H19; ENCIF12 added to H20
		25	Table 1.5 Pin Assignments (320-Pin FBGA) (4 / 8): ENCIF10 added to J19
		26	Table 1.5 Pin Assignments (320-Pin FBGA) (5 / 8): ENCIF09 added to N20; ENCIF08 added to P20
		27	Table 1.5 Pin Assignments (320-Pin FBGA) (6 / 8): ENCIF09 added to U3
		28	Table 1.5 Pin Assignments (320-Pin FBGA) (7 / 8): ENCIF10 added to W3; ENCIF11 added to W4; ENCIF08 added to W10; ENCIF12 added to Y4
		35	Table 1.7 List of Pin and Pin Functions (320-Pin FBGA) (2 / 10): ENCIF12 added to B19 under "Others"; ENCIF11 added to B20 under "Others"
		36	Table 1.7 List of Pin and Pin Functions (320-Pin FBGA) (3 / 10): ENCIF10 added to C19 under "Others"; ENCIF09 added to D19 under "Others"; ENCIF08 added to E19 under "Others"
		38	Table 1.7 List of Pin and Pin Functions (320-Pin FBGA) (5 / 10): ENCIF11 added to H19 under "Others"; ENCIF12 added to H20 under "Others"; ENCIF10 added to J19 under "Others"
		40	Table 1.7 List of Pin and Pin Functions (320-Pin FBGA) (7 / 10): ENCIF09 added to N20 under "Others"; ENCIF08 added to P20 under "Others"
		41	Table 1.7 List of Pin and Pin Functions (320-Pin FBGA) (8 / 10): ENCIF09 added to U3 under "Others"
		42	Table 1.7 List of Pin and Pin Functions (320-Pin FBGA) (9 / 10): ENCIF10 added to W3 under "Others"; ENCIF11 added to W4 under "Others"; ENCIF08 added to W10 under "Others"; ENCIF12 added to Y4
			2. Electrical Characteristics
		54	Table 2.3 DC Characteristics (2) [Power Supply]: Entries added to the "300MHz" row of VDD
		65, 66	Table 2.17 Bus Timing: "CKIO = 75MHz" changed to "CKIO = 1/tCKcyc"; "t <sub>cy</sub> " changed to "t <sub>CKcyc</sub> "; entries for "Address delay time 1", "CS# delay time 1", "Read/write delay time 1", "Read data setup time 1 to 3" and "WAIT# setup time" changed; Notes 1, 3, and 4 changed
		102	Table 2.27 RSPIa Timing: Note 2 changed (SSLND → SPCKD); Note 3 added
111	Figure 2.64 RIICa Bus Interface Input/Output Timing: SDA0 to SDA3 and SCL0 to SCL3 deleted		

Rev.	Date	Description	
		Page	Summary
1.50	Dec. 26, 2018	All	The company name, modified (ARM → Arm)
		Features	
		1	■ Encoder interfaces (optional): The descriptions and related note 4, added
		Section 1 Overview	
		2	Table 1.1 Outline of Specifications (1/7): Central processing unit (Cortex-M3): The architecture type, corrected (Arm v7-R architecture → Arm v7-M architecture)
		2	Table 1.1 Outline of Specifications (1/7): On-chip extended SRAM with ECC: The entry "Operating frequency", added
		2	Table 1.1 Outline of Specifications (1/7): Operating modes: The description, modified
		3	Table 1.1 Outline of Specifications (2/7): DMAC: Activation sources, modified
		3	Table 1.1 Outline of Specifications (2/7): ELC: The number of event signals, modified
		4	Table 1.1 Outline of Specifications (3/7): TPUa: The descriptions for pulse input/output, PWM mode, PPG output trigger, event linking, modified
		4	Table 1.1 Outline of Specifications (3/7): MTU3a: The number of counter-input clock signals, modified; the feature "automatic transfer of register data", deleted; the description of phase-counting mode, modified
		5	Table 1.1 Outline of Specifications (4/7): CMT: Event linking, modified
		5	Table 1.1 Outline of Specifications (4/7): POE3: Pin names, corrected
		6	Table 1.1 Outline of Specifications (5/7): ETHERC: The description in relation with "1 port", modified
		7	Table 1.1 Outline of Specifications (6/7): SSI: "programmable word clock", deleted from the clock to be generated
		7	Table 1.1 Outline of Specifications (6/7): DSMIF: The description in relation with channel, modified
		8	Table 1.1 Outline of Specifications (7/7): Encoder interfaces: The number of channels and note 6, added
		12	Figure 1.1 Block Diagram: The number of channels of MTU3a and DSMIF, modified
		14	Table 1.4 Pin Functions (2/7): Pin names, modified (A0 to A25 → A25 to A0, D0 to D31 → D31 to D0); the "Description" column for RAS# and CAS#, modified
		15	Table 1.4 Pin Functions (3/7): The "Description" column for MTIOC8A to MTIOC8D and for GPTa, modified
		16	Table 1.4 Pin Functions (4/7): The "Description" column for each TPUa pin, modified
		17	Table 1.4 Pin Functions (5/7): Ethernet controller (ETHERC): ETH0_RXC, ETH1_RXC, ETH2_RXC: The "I/O" and "Description" columns, modified (I/O → Input, Receive clock I/O pins → Receive clock input pins)
		18	Table 1.4 Pin Functions (6/7): The AUDIO_CLK pin, added
		2. Electrical Characteristics	
		51	Figure 2.1 Power On/Off Sequence: "Timing" table: "—" was added to the "Value (typ)" column for Nos (3), (4), and (5).
		53	Table 2.3 DC Characteristics (2) [Power Supply] (1 / 2): V <sub>lcc</sub> when VDD is 300 MHz in normal operation, modified
		56	Table 2.5 DC Characteristics (4) [USB2.0 USB_RREF Pin]: The "min" column, modified (200Ω ±1% → 200 ±1%); the "Ω" in the "Unit" column, added
		60	Table 2.12 CLKOUT25Mn Timing, modified (CLKOUT25Mn (RMII): T <sub>ck</sub> → T <sub>ck1</sub> , CLKOUT25Mn (MII): T <sub>ck</sub> → T <sub>ck2</sub> )
		60	Figure 2.3 CLKOUT25Mn Pin Output Timing 1: Symbols, modified
		60	Figure 2.4 CLKOUT25Mn Pin Output Timing 2: Symbols, modified
		61	Table 2.13 EXTAL Clock Timing: Time value, modified (40.00 + 50 ppm → 40.00 ± 50 ppm)
		61	Table 2.14 XTAL Clock Timing: Time value, modified (40.00 + 50 ppm → 40.00 ± 50 ppm)
		98	Table 2.24 GPTa Timing: The symbol, modified (T <sub>OTETW</sub> → t <sub>GTEW</sub> )
		102	Table 2.27 RSPIa Timing: Note 4, added

## General Precautions in the Handling of Microprocessing Unit and Microcontroller Unit Products

The following usage notes are applicable to all Microprocessing unit and Microcontroller unit products from Renesas. For detailed usage notes on the products covered by this document, refer to the relevant sections of the document as well as any technical updates that have been issued for the products.

### 1. Handling of Unused Pins

Handle unused pins in accordance with the directions given under Handling of Unused Pins in the manual.

- The input pins of CMOS products are generally in the high-impedance state. In operation with an unused pin in the open-circuit state, extra electromagnetic noise is induced in the vicinity of LSI, an associated shoot-through current flows internally, and malfunctions occur due to the false recognition of the pin state as an input signal become possible. Unused pins should be handled as described under Handling of Unused Pins in the manual.

### 2. Processing at Power-on

The state of the product is undefined at the moment when power is supplied.

- The states of internal circuits in the LSI are indeterminate and the states of register settings and pins are undefined at the moment when power is supplied.

In a finished product where the reset signal is applied to the external reset pin, the states of pins are not guaranteed from the moment when power is supplied until the reset process is completed. In a similar way, the states of pins in a product that is reset by an on-chip power-on reset function are not guaranteed from the moment when power is supplied until the power reaches the level at which resetting has been specified.

### 3. Prohibition of Access to Reserved Addresses

Access to reserved addresses is prohibited.

- The reserved addresses are provided for the possible future expansion of functions. Do not access these addresses; the correct operation of LSI is not guaranteed if they are accessed.

### 4. Clock Signals

After applying a reset, only release the reset line after the operating clock signal has become stable.

When switching the clock signal during program execution, wait until the target clock signal has stabilized.

- When the clock signal is generated with an external resonator (or from an external oscillator) during a reset, ensure that the reset line is only released after full stabilization of the clock signal. Moreover, when switching to a clock signal produced with an external resonator (or by an external oscillator) while program execution is in progress, wait until the target clock signal is stable.

### 5. Differences between Products

Before changing from one product to another, i.e. to a product with a different part number, confirm that the change will not lead to problems.

- The characteristics of Microprocessing unit or Microcontroller unit products in the same group but having a different part number may differ in terms of the internal memory capacity, layout pattern, and other factors, which can affect the ranges of electrical characteristics, such as characteristic values, operating margins, immunity to noise, and amount of radiated noise. When changing to a product with a different part number, implement a system-evaluation test for the given product.

## Notice

1. Descriptions of circuits, software and other related information in this document are provided only to illustrate the operation of semiconductor products and application examples. You are fully responsible for the incorporation or any other use of the circuits, software, and information in the design of your product or system. Renesas Electronics disclaims any and all liability for any losses and damages incurred by you or third parties arising from the use of these circuits, software, or information.
2. Renesas Electronics hereby expressly disclaims any warranties against and liability for infringement or any other claims involving patents, copyrights, or other intellectual property rights of third parties, by or arising from the use of Renesas Electronics products or technical information described in this document, including but not limited to, the product data, drawings, charts, programs, algorithms, and application examples.
3. No license, express, implied or otherwise, is granted hereby under any patents, copyrights or other intellectual property rights of Renesas Electronics or others.
4. You shall not alter, modify, copy, or reverse engineer any Renesas Electronics product, whether in whole or in part. Renesas Electronics disclaims any and all liability for any losses or damages incurred by you or third parties arising from such alteration, modification, copying or reverse engineering.
5. Renesas Electronics products are classified according to the following two quality grades: "Standard" and "High Quality". The intended applications for each Renesas Electronics product depends on the product's quality grade, as indicated below.  
"Standard": Computers; office equipment; communications equipment; test and measurement equipment; audio and visual equipment; home electronic appliances; machine tools; personal electronic equipment; industrial robots; etc.  
"High Quality": Transportation equipment (automobiles, trains, ships, etc.); traffic control (traffic lights); large-scale communication equipment; key financial terminal systems; safety control equipment; etc.  
Unless expressly designated as a high reliability product or a product for harsh environments in a Renesas Electronics data sheet or other Renesas Electronics document, Renesas Electronics products are not intended or authorized for use in products or systems that may pose a direct threat to human life or bodily injury (artificial life support devices or systems; surgical implantations; etc.), or may cause serious property damage (space system; undersea repeaters; nuclear power control systems; aircraft control systems; key plant systems; military equipment; etc.). Renesas Electronics disclaims any and all liability for any damages or losses incurred by you or any third parties arising from the use of any Renesas Electronics product that is inconsistent with any Renesas Electronics data sheet, user's manual or other Renesas Electronics document.
6. When using Renesas Electronics products, refer to the latest product information (data sheets, user's manuals, application notes, "General Notes for Handling and Using Semiconductor Devices" in the reliability handbook, etc.), and ensure that usage conditions are within the ranges specified by Renesas Electronics with respect to maximum ratings, operating power supply voltage range, heat dissipation characteristics, installation, etc. Renesas Electronics disclaims any and all liability for any malfunctions, failure or accident arising out of the use of Renesas Electronics products outside of such specified ranges.
7. Although Renesas Electronics endeavors to improve the quality and reliability of Renesas Electronics products, semiconductor products have specific characteristics, such as the occurrence of failure at a certain rate and malfunctions under certain use conditions. Unless designated as a high reliability product or a product for harsh environments in a Renesas Electronics data sheet or other Renesas Electronics document, Renesas Electronics products are not subject to radiation resistance design. You are responsible for implementing safety measures to guard against the possibility of bodily injury, injury or damage caused by fire, and/or danger to the public in the event of a failure or malfunction of Renesas Electronics products, such as safety design for hardware and software, including but not limited to redundancy, fire control and malfunction prevention, appropriate treatment for aging degradation or any other appropriate measures. Because the evaluation of microcomputer software alone is very difficult and impractical, you are responsible for evaluating the safety of the final products or systems manufactured by you.
8. Please contact a Renesas Electronics sales office for details as to environmental matters such as the environmental compatibility of each Renesas Electronics product. You are responsible for carefully and sufficiently investigating applicable laws and regulations that regulate the inclusion or use of controlled substances, including without limitation, the EU RoHS Directive, and using Renesas Electronics products in compliance with all these applicable laws and regulations. Renesas Electronics disclaims any and all liability for damages or losses occurring as a result of your noncompliance with applicable laws and regulations.
9. Renesas Electronics products and technologies shall not be used for or incorporated into any products or systems whose manufacture, use, or sale is prohibited under any applicable domestic or foreign laws or regulations. You shall comply with any applicable export control laws and regulations promulgated and administered by the governments of any countries asserting jurisdiction over the parties or transactions.
10. It is the responsibility of the buyer or distributor of Renesas Electronics products, or any other party who distributes, disposes of, or otherwise sells or transfers the product to a third party, to notify such third party in advance of the contents and conditions set forth in this document.
11. This document shall not be reprinted, reproduced or duplicated in any form, in whole or in part, without prior written consent of Renesas Electronics.
12. Please contact a Renesas Electronics sales office if you have any questions regarding the information contained in this document or Renesas Electronics products.

(Note 1) "Renesas Electronics" as used in this document means Renesas Electronics Corporation and also includes its directly or indirectly controlled subsidiaries.

(Note 2) "Renesas Electronics product(s)" means any product developed or manufactured by or for Renesas Electronics.

(Rev.4.0-1 November 2017)



### SALES OFFICES

Renesas Electronics Corporation

<http://www.renesas.com>

Refer to "<http://www.renesas.com/>" for the latest and detailed information.

#### **Renesas Electronics Corporation**

TOYOSU FORESIA, 3-2-24 Toyosu, Koto-ku, Tokyo 135-0061, Japan

#### **Renesas Electronics America Inc.**

1001 Murphy Ranch Road, Milpitas, CA 95035, U.S.A.  
Tel: +1-408-432-8888, Fax: +1-408-434-5351

#### **Renesas Electronics Canada Limited**

9251 Yonge Street, Suite 8309 Richmond Hill, Ontario Canada L4C 9T3  
Tel: +1-905-237-2004

#### **Renesas Electronics Europe Limited**

Dukes Meadow, Millboard Road, Bourne End, Buckinghamshire, SL8 5FH, U.K.  
Tel: +44-1628-651-700

#### **Renesas Electronics Europe GmbH**

Arcadiastrasse 10, 40472 Düsseldorf, Germany  
Tel: +49-211-6503-0, Fax: +49-211-6503-1327

#### **Renesas Electronics (China) Co., Ltd.**

Room 1709 Quantum Plaza, No.27 ZhichunLu, Haidian District, Beijing, 100191 P. R. China  
Tel: +86-10-8235-1155, Fax: +86-10-8235-7679

#### **Renesas Electronics (Shanghai) Co., Ltd.**

Unit 301, Tower A, Central Towers, 555 Langao Road, Putuo District, Shanghai, 200333 P. R. China  
Tel: +86-21-2226-0888, Fax: +86-21-2226-0999

#### **Renesas Electronics Hong Kong Limited**

Unit 1601-1611, 16/F., Tower 2, Grand Century Place, 193 Prince Edward Road West, Mongkok, Kowloon, Hong Kong  
Tel: +852-2265-6688, Fax: +852-2886-9022

#### **Renesas Electronics Taiwan Co., Ltd.**

13F, No. 363, Fu Shing North Road, Taipei 10543, Taiwan  
Tel: +886-2-8175-9600, Fax: +886-2-8175-9670

#### **Renesas Electronics Singapore Pte. Ltd.**

80 Bendemeer Road, Unit #06-02 Hyflux Innovation Centre, Singapore 339949  
Tel: +65-6213-0200, Fax: +65-6213-0300

#### **Renesas Electronics Malaysia Sdn.Bhd.**

Unit 1207, Block B, Menara Amcorp, Amcorp Trade Centre, No. 18, Jln Persiaran Barat, 46050 Petaling Jaya, Selangor Darul Ehsan, Malaysia  
Tel: +60-3-7955-9390, Fax: +60-3-7955-9510

#### **Renesas Electronics India Pvt. Ltd.**

No.777C, 100 Feet Road, HAL 2nd Stage, Indiranagar, Bangalore 560 038, India  
Tel: +91-80-67208700, Fax: +91-80-67208777

#### **Renesas Electronics Korea Co., Ltd.**

17F, KAMCO Yangjae Tower, 262, Gangnam-daero, Gangnam-gu, Seoul, 06265 Korea  
Tel: +82-2-558-3737, Fax: +82-2-558-5338

# Mouser Electronics

Authorized Distributor

Click to View Pricing, Inventory, Delivery & Lifecycle Information:

## Renesas Electronics:

[R7S910006CBG#AC0](#) [R7S910001CFP#AA0](#) [R7S910025CBG#AC0](#) [R7S910007CBG#AC0](#) [R7S910017CBG#AC0](#)  
[R7S910018CBG#AC0](#) [R7S910027CBG#AC0](#) [R7S910016CBG#AC0](#) [R7S910015CBG#AC0](#) [R7S910026CBG#AC0](#)  
[R7S910013CBG#AC0](#) [R7S910011CBG#AC0](#) [R7S910028CBG#AC0](#) [R7S910002CBG#AC0](#) [R7S910035CBG#AC0](#)  
[R7S910036CBG#AC0](#)



Компания «Океан Электроники» предлагает заключение долгосрочных отношений при поставках импортных электронных компонентов на взаимовыгодных условиях!

Наши преимущества:

- Поставка оригинальных импортных электронных компонентов напрямую с производств Америки, Европы и Азии, а так же с крупнейших складов мира;
- Широкая линейка поставок активных и пассивных импортных электронных компонентов (более 30 млн. наименований);
- Поставка сложных, дефицитных, либо снятых с производства позиций;
- Оперативные сроки поставки под заказ (от 5 рабочих дней);
- Экспресс доставка в любую точку России;
- Помощь Конструкторского Отдела и консультации квалифицированных инженеров;
- Техническая поддержка проекта, помощь в подборе аналогов, поставка прототипов;
- Поставка электронных компонентов под контролем ВП;
- Система менеджмента качества сертифицирована по Международному стандарту ISO 9001;
- При необходимости вся продукция военного и аэрокосмического назначения проходит испытания и сертификацию в лаборатории (по согласованию с заказчиком);
- Поставка специализированных компонентов военного и аэрокосмического уровня качества (Xilinx, Altera, Analog Devices, Intersil, Interpoint, Microsemi, Actel, Aeroflex, Peregrine, VPT, Syfer, Eurofarad, Texas Instruments, MS Kennedy, Miteq, Cobham, E2V, MA-COM, Hittite, Mini-Circuits, General Dynamics и др.);

Компания «Океан Электроники» является официальным дистрибьютором и эксклюзивным представителем в России одного из крупнейших производителей разъемов военного и аэрокосмического назначения «JONHON», а так же официальным дистрибьютором и эксклюзивным представителем в России производителя высокотехнологичных и надежных решений для передачи СВЧ сигналов «FORSTAR».



## JONHON

«JONHON» (основан в 1970 г.)

Разъемы специального, военного и аэрокосмического назначения:

(Применяются в военной, авиационной, аэрокосмической, морской, железнодорожной, горно- и нефтедобывающей отраслях промышленности)

«FORSTAR» (основан в 1998 г.)

ВЧ соединители, коаксиальные кабели, кабельные сборки и микроволновые компоненты:

(Применяются в телекоммуникациях гражданского и специального назначения, в средствах связи, РЛС, а так же военной, авиационной и аэрокосмической отраслях промышленности).



Телефон: 8 (812) 309-75-97 (многоканальный)

Факс: 8 (812) 320-03-32

Электронная почта: [ocean@oceanchips.ru](mailto:ocean@oceanchips.ru)

Web: <http://oceanchips.ru/>

Адрес: 198099, г. Санкт-Петербург, ул. Калинина, д. 2, корп. 4, лит. А