



**MICROCHIP**

---

**PIC24F16KA102 Family  
Data Sheet**

20/28-Pin General Purpose,  
16-Bit Flash Microcontrollers  
with nanoWatt XLP Technology

---

**Note the following details of the code protection feature on Microchip devices:**

- Microchip products meet the specification contained in their particular Microchip Data Sheet.
- Microchip believes that its family of products is one of the most secure families of its kind on the market today, when used in the intended manner and under normal conditions.
- There are dishonest and possibly illegal methods used to breach the code protection feature. All of these methods, to our knowledge, require using the Microchip products in a manner outside the operating specifications contained in Microchip's Data Sheets. Most likely, the person doing so is engaged in theft of intellectual property.
- Microchip is willing to work with the customer who is concerned about the integrity of their code.
- Neither Microchip nor any other semiconductor manufacturer can guarantee the security of their code. Code protection does not mean that we are guaranteeing the product as "unbreakable."

Code protection is constantly evolving. We at Microchip are committed to continuously improving the code protection features of our products. Attempts to break Microchip's code protection feature may be a violation of the Digital Millennium Copyright Act. If such acts allow unauthorized access to your software or other copyrighted work, you may have a right to sue for relief under that Act.

---

Information contained in this publication regarding device applications and the like is provided only for your convenience and may be superseded by updates. It is your responsibility to ensure that your application meets with your specifications. MICROCHIP MAKES NO REPRESENTATIONS OR WARRANTIES OF ANY KIND WHETHER EXPRESS OR IMPLIED, WRITTEN OR ORAL, STATUTORY OR OTHERWISE, RELATED TO THE INFORMATION, INCLUDING BUT NOT LIMITED TO ITS CONDITION, QUALITY, PERFORMANCE, MERCHANTABILITY OR FITNESS FOR PURPOSE. Microchip disclaims all liability arising from this information and its use. Use of Microchip devices in life support and/or safety applications is entirely at the buyer's risk, and the buyer agrees to defend, indemnify and hold harmless Microchip from any and all damages, claims, suits, or expenses resulting from such use. No licenses are conveyed, implicitly or otherwise, under any Microchip intellectual property rights.

**Trademarks**

The Microchip name and logo, the Microchip logo, dsPIC, KEELOQ, KEELOQ logo, MPLAB, PIC, PICmicro, PICSTART, PIC<sup>32</sup> logo, rPIC and UNI/O are registered trademarks of Microchip Technology Incorporated in the U.S.A. and other countries.

FilterLab, Hampshire, HI-TECH C, Linear Active Thermistor, MXDEV, MXLAB, SEEVAL and The Embedded Control Solutions Company are registered trademarks of Microchip Technology Incorporated in the U.S.A.

Analog-for-the-Digital Age, Application Maestro, chipKIT, chipKIT logo, CodeGuard, dsPICDEM, dsPICDEM.net, dsPICworks, dsSPEAK, ECAN, ECONOMONITOR, FanSense, HI-TIDE, In-Circuit Serial Programming, ICSP, Mindi, MiWi, MPASM, MPLAB Certified logo, MPLIB, MPLINK, mTouch, Omniscient Code Generation, PICC, PICC-18, PICDEM, PICDEM.net, PICkit, PICtail, REAL ICE, rLAB, Select Mode, Total Endurance, TSHARC, UniWinDriver, WiperLock and ZENA are trademarks of Microchip Technology Incorporated in the U.S.A. and other countries.

SQTP is a service mark of Microchip Technology Incorporated in the U.S.A.

All other trademarks mentioned herein are property of their respective companies.

© 2008-2011, Microchip Technology Incorporated, Printed in the U.S.A., All Rights Reserved.

 Printed on recycled paper.

ISBN: 978-1-61341-690-7

**QUALITY MANAGEMENT SYSTEM**  
**CERTIFIED BY DNV**  
**== ISO/TS 16949:2009 ==**

*Microchip received ISO/TS-16949:2009 certification for its worldwide headquarters, design and wafer fabrication facilities in Chandler and Tempe, Arizona; Gresham, Oregon and design centers in California and India. The Company's quality system processes and procedures are for its PIC<sup>®</sup> MCUs and dsPIC<sup>®</sup> DSCs, KEELOQ<sup>®</sup> code hopping devices, Serial EEPROMs, microperipherals, nonvolatile memory and analog products. In addition, Microchip's quality system for the design and manufacture of development systems is ISO 9001:2000 certified.*



# PIC24F16KA102 FAMILY

## 20/28-Pin General Purpose, 16-Bit Flash Microcontrollers with nanoWatt XLP Technology

### Power Management Modes:

- Run – CPU, Flash, SRAM and Peripherals On
- Doze – CPU Clock Runs Slower than Peripherals
- Idle – CPU Off, Flash, SRAM and Peripherals On
- Sleep – CPU, Flash and Peripherals Off and SRAM On
- Deep Sleep – CPU, Flash, SRAM and Most Peripherals Off:
  - Run mode currents down to 8  $\mu$ A typical
  - Idle mode currents down to 2  $\mu$ A typical
  - Deep Sleep mode currents down to 20 nA typical
  - RTCC 490 nA, 32 kHz, 1.8V
  - Watchdog Timer 350 nA, 1.8V typical

### High-Performance CPU:

- Modified Harvard Architecture
- Up to 16 MIPS Operation @ 32 MHz
- 8 MHz Internal Oscillator with 4x PLL Option and Multiple Divide Options
- 17-Bit by 17-Bit Single-Cycle Hardware Multiplier
- 32-Bit by 16-Bit Hardware Divider
- 16-Bit x 16-Bit Working Register Array
- C Compiler Optimized Instruction Set Architecture

### Peripheral Features:

- Hardware Real-Time Clock and Calendar (RTCC):
  - Provides clock, calendar and alarm functions
  - Can run in Deep Sleep Mode
- Programmable Cyclic Redundancy Check (CRC)
- Serial Communication modules:
  - SPI, I<sup>2</sup>C™ and two UART modules
- Three 16-Bit Timers/Counters with Programmable Prescaler
- 16-Bit Capture Inputs
- 16-Bit Compare/PWM Output
- Configurable Open-Drain Outputs on Digital I/O Pins
- Up to Three External Interrupt Sources

### Analog Features:

- 10-Bit, up to 9-Channel Analog-to-Digital Converter:
  - 500 kps conversion rate
  - Conversion available during Sleep and Idle
- Dual Analog Comparators with Programmable Input/Output Configuration
- Charge Time Measurement Unit (CTMU):
  - Used for capacitance sensing
  - Time measurement, down to 1 ns resolution
  - Delay/pulse generation, down to 1 ns resolution

### Special Microcontroller Features:

- Operating Voltage Range of 1.8V to 3.6V
- High-Current Sink/Source (18 mA/18 mA) on All I/O Pins
- Flash Program Memory:
  - Erase/write cycles: 10,000 minimum
  - 40-years' data retention minimum
- Data EEPROM:
  - Erase/write cycles: 100,000 minimum
  - 40-years' data retention minimum
- Fail-Safe Clock Monitor
- System Frequency Range Declaration bits:
  - Declaring the frequency range optimizes the current consumption.
- Flexible Watchdog Timer (WDT) with On-Chip, Low-Power RC Oscillator for Reliable Operation
- In-Circuit Serial Programming™ (ICSP™) and In-Circuit Debug (ICD) via two Pins
- Programmable High/Low-Voltage Detect (HLVD)
- Brown-out Reset (BOR):
  - Standard BOR with three programmable trip points; can be disabled in Sleep
- Extreme Low-Power DSBOR for Deep Sleep, LPBOR for all other modes

PIC24F Device	Pins	Program Memory (bytes)	SRAM (bytes)	Data EEPROM (bytes)	Timers 16-Bit	Capture Input	Output Compare/PWM	UART/IrDA®	SPI	I <sup>2</sup> C™	10-Bit A/D (ch)	Comparators	CTMU (ch)	RTCC
08KA101	20	8K	1.5K	512	3	1	1	2	1	1	9	2	9	Y
16KA101	20	16K	1.5K	512	3	1	1	2	1	1	9	2	9	Y
08KA102	28	8K	1.5K	512	3	1	1	2	1	1	9	2	9	Y
16KA102	28	16K	1.5K	512	3	1	1	2	1	1	9	2	9	Y

# PIC24F16KA102 FAMILY

## Pin Diagrams

### 20-Pin PDIP, SSOP, SOIC<sup>(2)</sup>



### 28-Pin SPDIP, SSOP, SOIC<sup>(2)</sup>

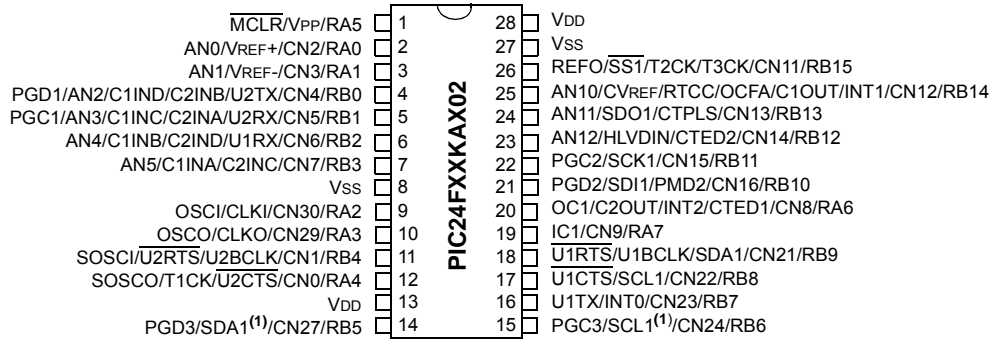

- Note 1:** Alternative multiplexing for SDA1 and SCL1 when the I2CSEL Configuration bit is set.  
**Note 2:** All device pins have a maximum voltage of 3.6V and are not 5V tolerant.

# PIC24F16KA102 FAMILY

## Pin Diagrams (Continued)

20-Pin QFN<sup>(1,2)</sup>



- Note 1:** The bottom pad of the QFN package should be connected to Vss.
- Note 2:** All device pins have a maximum voltage of 3.6V and are not 5V tolerant.

# PIC24F16KA102 FAMILY

## Pin Diagrams (Continued)



# PIC24F16KA102 FAMILY

---

## Table of Contents

1.0	Device Overview .....	9
2.0	Guidelines for Getting Started with 16-Bit Microcontrollers .....	17
3.0	CPU .....	23
4.0	Memory Organization .....	29
5.0	Flash Program Memory .....	45
6.0	Data EEPROM Memory .....	51
7.0	Resets .....	57
8.0	Interrupt Controller .....	63
9.0	Oscillator Configuration .....	91
10.0	Power-Saving Features .....	101
11.0	I/O Ports .....	113
12.0	Timer1 .....	115
13.0	Timer2/3 .....	117
14.0	Input Capture .....	123
15.0	Output Compare .....	125
16.0	Serial Peripheral Interface (SPI) .....	131
17.0	Inter-Integrated Circuit (I <sup>2</sup> C™) .....	139
18.0	Universal Asynchronous Receiver Transmitter (UART) .....	147
19.0	Real-Time Clock and Calendar (RTCC) .....	155
20.0	Programmable Cyclic Redundancy Check (CRC) Generator .....	167
21.0	High/Low-Voltage Detect (HLVD) .....	171
22.0	10-Bit High-Speed A/D Converter .....	173
23.0	Comparator Module .....	183
24.0	Comparator Voltage Reference .....	187
25.0	Charge Time Measurement Unit (CTMU) .....	189
26.0	Special Features .....	193
27.0	Development Support .....	203
28.0	Instruction Set Summary .....	207
29.0	Electrical Characteristics .....	215
30.0	Packaging Information .....	251
	Appendix A: Revision History .....	269
	Index .....	271
	The Microchip Web Site .....	275
	Customer Change Notification Service .....	275
	Customer Support .....	275
	Reader Response .....	276
	Product Identification System .....	277

# PIC24F16KA102 FAMILY

---

---

## TO OUR VALUED CUSTOMERS

It is our intention to provide our valued customers with the best documentation possible to ensure successful use of your Microchip products. To this end, we will continue to improve our publications to better suit your needs. Our publications will be refined and enhanced as new volumes and updates are introduced.

If you have any questions or comments regarding this publication, please contact the Marketing Communications Department via E-mail at [docerrors@microchip.com](mailto:docerrors@microchip.com) or fax the **Reader Response Form** in the back of this data sheet to (480) 792-4150. We welcome your feedback.

### Most Current Data Sheet

To obtain the most up-to-date version of this data sheet, please register at our Worldwide Web site at:

<http://www.microchip.com>

You can determine the version of a data sheet by examining its literature number found on the bottom outside corner of any page. The last character of the literature number is the version number, (e.g., DS30000A is version A of document DS30000).

### Errata

An errata sheet, describing minor operational differences from the data sheet and recommended workarounds, may exist for current devices. As device/documentation issues become known to us, we will publish an errata sheet. The errata will specify the revision of silicon and revision of document to which it applies.

To determine if an errata sheet exists for a particular device, please check with one of the following:

- Microchip's Worldwide Web site; <http://www.microchip.com>
- Your local Microchip sales office (see last page)

When contacting a sales office, please specify which device, revision of silicon and data sheet (include literature number) you are using.

### Customer Notification System

Register on our web site at [www.microchip.com](http://www.microchip.com) to receive the most current information on all of our products.



# PIC24F16KA102 FAMILY

---

## 1.0 DEVICE OVERVIEW

This document contains device-specific information for the following devices:

- PIC24F08KA101
- PIC24F16KA101
- PIC24F08KA102
- PIC24F16KA102

The PIC24F16KA102 family introduces a new line of extreme low-power Microchip devices: a 16-bit microcontroller family with a broad peripheral feature set and enhanced computational performance. It also offers a new migration option for those high-performance applications, which may be outgrowing their 8-bit platforms, but do not require the numerical processing power of a digital signal processor.

## 1.1 Core Features

### 1.1.1 16-BIT ARCHITECTURE

Central to all PIC24F devices is the 16-bit modified Harvard architecture, first introduced with Microchip's dsPIC<sup>®</sup> digital signal controllers. The PIC24F CPU core offers a wide range of enhancements, such as:

- 16-bit data and 24-bit address paths with the ability to move information between data and memory spaces
- Linear addressing of up to 12 Mbytes (program space) and 64 Kbytes (data)
- A 16-element working register array with built-in software stack support
- A 17 x 17 hardware multiplier with support for integer math
- Hardware support for 32-bit by 16-bit division
- An instruction set that supports multiple addressing modes and is optimized for high-level languages, such as C
- Operational performance up to 16 MIPS

### 1.1.2 POWER-SAVING TECHNOLOGY

All of the devices in the PIC24F16KA102 family incorporate a range of features that can significantly reduce power consumption during operation. Key items include:

- **On-the-Fly Clock Switching:** The device clock can be changed under software control to the Timer1 source or the internal, low-power RC oscillator during operation, allowing users to incorporate power-saving ideas into their software designs.
- **Doze Mode Operation:** When timing-sensitive applications, such as serial communications, require the uninterrupted operation of peripherals, the CPU clock speed can be selectively reduced, allowing incremental power savings without missing a beat.
- **Instruction-Based Power-Saving Modes:** There are three instruction-based power-saving modes:
  - Idle Mode: The core is shut down while leaving the peripherals active.
  - Sleep Mode: The core and peripherals that require the system clock are shut down, leaving the peripherals that use their own clock, or the clock from other devices, active.
  - Deep Sleep Mode: The core, peripherals (except RTCC and DSWDT), Flash and SRAM are shut down.

### 1.1.3 OSCILLATOR OPTIONS AND FEATURES

The PIC24F16KA102 family offers five different oscillator options, allowing users a range of choices in developing application hardware. These include:

- Two Crystal modes using crystals or ceramic resonators.
- Two External Clock modes offering the option of a divide-by-2 clock output.
- Two Fast Internal Oscillators (FRCs): One with a nominal 8 MHz output and the other with a nominal 500 kHz output. These outputs can also be divided under software control to provide clock speed as low as 31 kHz or 2 kHz.
- A Phase Locked Loop (PLL) frequency multiplier, available to the External Oscillator modes and the 8 MHz FRC oscillator, which allows clock speeds of up to 32 MHz.
- A separate Internal RC oscillator (LPRC) with a fixed 31 kHz output, which provides a low-power option for timing-insensitive applications.

# PIC24F16KA102 FAMILY

---

The internal oscillator block also provides a stable reference source for the Fail-Safe Clock Monitor (FSCM). This option constantly monitors the main clock source against a reference signal provided by the internal oscillator and enables the controller to switch to the internal oscillator, allowing for continued low-speed operation or a safe application shutdown.

## 1.1.4 EASY MIGRATION

Regardless of the memory size, all the devices share the same rich set of peripherals, allowing for a smooth migration path as applications grow and evolve.

The consistent pinout scheme used throughout the entire family also helps in migrating to the next larger device. This is true when moving between devices with the same pin count, or even jumping from 20-pin to 28-pin devices.

The PIC24F family is pin compatible with devices in the dsPIC33 family, and shares some compatibility with the pinout schema for PIC18 and dsPIC30. This extends the ability of applications to grow from the relatively simple, to the powerful and complex.

## 1.2 Other Special Features

- **Communications:** The PIC24F16KA102 family incorporates a range of serial communication peripherals to handle a range of application requirements. There is an I<sup>2</sup>C™ module that supports both the Master and Slave modes of operation. It also comprises UARTs with built-in IrDA® encoders/decoders and an SPI module.
- **Real-Time Clock/Calendar:** This module implements a full-featured clock and calendar with alarm functions in hardware, freeing up timer resources and program memory space for use of the core application.
- **10-Bit A/D Converter:** This module incorporates programmable acquisition time, allowing for a channel to be selected and a conversion to be initiated without waiting for a sampling period, and faster sampling speed. The 16-deep result buffer can be used either in Sleep to reduce power, or in Active mode to improve throughput.
- **Charge Time Measurement Unit (CTMU)**  
**Interface:** The PIC24F16KA102 family includes the new CTMU interface module, which can be used for capacitive touch sensing, proximity sensing and also for precision time measurement and pulse generation.

## 1.3 Details on Individual Family Members

Devices in the PIC24F16KA102 family are available in 20-pin and 28-pin packages. The general block diagram for all devices is displayed in [Figure 1-1](#).

The devices are different from each other in two ways:

1. Flash program memory (8 Kbytes for PIC24F08KA devices, 16 Kbytes for PIC24F16KA devices).
2. Available I/O pins and ports (18 pins on two ports for 20-pin devices and 24 pins on two ports for 28-pin devices).
3. Alternate SCLx and SDAx pins are available only in 28-pin devices and not in 20-pin devices.

All other features for devices in this family are identical; these are summarized in [Table 1-1](#).

A list of the pin features available on the PIC24F16KA102 family devices, sorted by function, is provided in [Table 1-2](#).

**Note:** [Table 1-1](#) provides the pin location of individual peripheral features and not how they are multiplexed on the same pin. This information is provided in the pinout diagrams on pages [4](#), [5](#) and [6](#) of the data sheet. Multiplexed features are sorted by the priority given to a feature, with the highest priority peripheral being listed first.

# PIC24F16KA102 FAMILY

**TABLE 1-1: DEVICE FEATURES FOR THE PIC24F16KA102 FAMILY**

Features	PIC24F08KA101	PIC24F16KA101	PIC24F08KA102	PIC24F16KA102
Operating Frequency	DC – 32 MHz			
Program Memory (bytes)	8K	16K	8K	16K
Program Memory (instructions)	2816	5632	2816	5632
Data Memory (bytes)	1536			
Data EEPROM Memory (bytes)	512			
Interrupt Sources (soft vectors/NMI traps)	30 (26/4)			
I/O Ports	PORTA<6:0> PORTB<15:12, 9:7, 4, 2:0>		PORTA<7:0> PORTB<15:0>	
Total I/O Pins	18		24	
Timers: Total Number (16-bit)	3			
32-Bit (from paired 16-bit timers)	1			
Input Capture Channels	1			
Output Compare/PWM Channels	1			
Input Change Notification Interrupt	17		23	
Serial Communications: UART	2			
SPI (3-wire/4-wire)	1			
I <sup>2</sup> C™	1			
10-Bit Analog-to-Digital Module (input channels)	9			
Analog Comparators	2			
Resets (and delays)	POR, BOR, RESET Instruction, $\overline{\text{MCLR}}$ , WDT, Illegal Opcode, REPEAT Instruction, Hardware Traps, Configuration Word Mismatch (PWRT, OST, PLL Lock)			
Instruction Set	76 Base Instructions, Multiple Addressing Mode Variations			
Packages	20-Pin PDIP/SSOP/SOIC/QFN		28-Pin SPDIP/SSOP/SOIC/QFN	

# PIC24F16KA102 FAMILY

FIGURE 1-1: PIC24F16KA102 FAMILY GENERAL BLOCK DIAGRAM



# PIC24F16KA102 FAMILY

**TABLE 1-2: PIC24F16KA102 FAMILY PINOUT DESCRIPTIONS**

Function	Pin Number				I/O	Input Buffer	Description
	20-Pin PDIP/SSOP/SOIC	20-Pin QFN	28-Pin SPDIP/SSOP/SOIC	28-Pin QFN			
AN0	2	19	2	27	I	ANA	A/D Analog Inputs
AN1	3	20	3	28	I	ANA	
AN2	4	1	4	1	I	ANA	
AN3	5	2	5	2	I	ANA	
AN4	7	4	6	3	I	ANA	
AN5	8	5	7	4	I	ANA	
AN10	17	14	25	22	I	ANA	
AN11	16	13	24	21	I	ANA	
AN12	15	12	23	20	I	ANA	
U1BCLK	13	10	18	15	O	—	
U2BCLK	9	6	11	8	O	—	UART2 IrDA Baud Clock
C1INA	8	5	7	4	I	ANA	Comparator 1 Input A (Positive Input)
C1INB	7	4	6	3	I	ANA	Comparator 1 Input B (Negative Input Option 1)
C1INC	5	2	5	2	I	ANA	Comparator Input C (Negative Input Option 2)
C1IND	4	1	4	1	I	ANA	Comparator Input D (Negative Input Option 3)
C1OUT	17	14	25	22	O	—	Comparator 1 Output
C2INA	5	2	5	2	I	ANA	Comparator 2 Input A (Positive Input)
C2INB	4	1	4	1	I	ANA	Comparator 2 Input B (Negative Input Option 1)
C2INC	8	5	7	4	I	ANA	Comparator 2 Input C (Negative Input Option 2)
C2IND	7	4	6	3	I	ANA	Comparator 2 Input D (Negative Input Option 3)
C2OUT	14	11	20	17	O	—	Comparator 2 Output
CLKI	7	4	9	6	I	ANA	Main Clock Input Connection
CLKO	8	5	10	7	O	—	System Clock Output

**Legend:** ST = Schmitt Trigger input buffer, ANA = Analog level input/output, I<sup>2</sup>C™ = I<sup>2</sup>C/SMBus input buffer

**Note 1:** Alternative multiplexing when the I2C1SEL Configuration bit is cleared.

# PIC24F16KA102 FAMILY

TABLE 1-2: PIC24F16KA102 FAMILY PINOUT DESCRIPTIONS (CONTINUED)

Function	Pin Number				I/O	Input Buffer	Description	
	20-Pin PDIP/SSOP/SOIC	20-Pin QFN	28-Pin SPDIP/SSOP/SOIC	28-Pin QFN				
CN0	10	7	12	9	I	ST	Interrupt-on-Change Inputs	
CN1	9	6	11	8	I	ST		
CN2	2	19	2	27	I	ST		
CN3	3	20	3	28	I	ST		
CN4	4	1	4	1	I	ST		
CN5	5	2	5	2	I	ST		
CN6	6	3	6	3	I	ST		
CN7	—	—	7	4	I	ST		
CN8	14	11	20	17	I	ST		
CN9	—	—	19	16	I	ST		
CN11	18	15	26	23	I	ST		
CN12	17	14	25	22	I	ST		
CN13	16	13	24	21	I	ST		
CN14	15	12	23	20	I	ST		
CN15	—	—	22	19	I	ST		
CN16	—	—	21	18	I	ST		
CN21	13	10	18	15	I	ST		
CN22	12	9	17	14	I	ST		
CN23	11	8	16	13	I	ST		
CN24	—	—	15	12	I	ST		
CN27	—	—	14	11	I	ST		
CN29	8	5	10	7	I	ST		
CN30	7	4	9	6	I	ST		
CVREF	17	14	25	22	O	ANA		Comparator Voltage Reference Output
CTED1	14	11	20	17	I	ST		CTMU Trigger Edge Input 1
CTED2	15	12	23	20	I	ST		CTMU Trigger Edge Input 2
CTPLS	16	13	24	21	O	—		CTMU Pulse Output
IC1	14	11	19	16	I	ST		Input Capture 1 Input
INT0	11	8	16	13	I	ST		External Interrupt Inputs
INT1	17	14	25	22	I	ST		
INT2	14	11	20	17	I	ST		
HLVDIN	15	12	23	20	I	ANA	HLVD Voltage Input	
MCLR	1	18	1	26	I	ST	Master Clear (device Reset) Input	
OC1	14	11	20	17	O	—	Output Compare/PWM Outputs	
OCFA	17	14	25	22	I	—	Output Compare Fault A	
OSCI	7	4	9	6	I	ANA	Main Oscillator Input Connection	
OSCO	8	5	10	7	O	ANA	Main Oscillator Output Connection	

**Legend:** ST = Schmitt Trigger input buffer, ANA = Analog level input/output, I<sup>2</sup>C™ = I<sup>2</sup>C/SMBus input buffer

**Note 1:** Alternative multiplexing when the I2C1SEL Configuration bit is cleared.

# PIC24F16KA102 FAMILY

**TABLE 1-2: PIC24F16KA102 FAMILY PINOUT DESCRIPTIONS (CONTINUED)**

Function	Pin Number				I/O	Input Buffer	Description
	20-Pin PDIP/SSOP/ SOIC	20-Pin QFN	28-Pin SPDIP/ SSOP/SOIC	28-Pin QFN			
PGC1	5	2	5	2	I/O	ST	In-Circuit Debugger and ICSP™ Programming Clock
PGD1	4	1	4	1	I/O	ST	In-Circuit Debugger and ICSP Programming Data
PGC2	2	19	22	19	I/O	ST	In-Circuit Debugger and ICSP Programming Clock
PGD2	3	20	21	18	I/O	ST	In-Circuit Debugger and ICSP Programming Data
PGC3	10	7	15	12	I/O	ST	In-Circuit Debugger and ICSP Programming Clock
PGD3	9	6	14	11	I/O	ST	In-Circuit Debugger and ICSP Programming Data
RA0	2	19	2	27	I/O	ST	PORTA Digital I/O
RA1	3	20	3	28	I/O	ST	
RA2	7	4	9	6	I/O	ST	
RA3	8	5	10	7	I/O	ST	
RA4	10	7	12	9	I/O	ST	
RA5	1	18	1	26	I/O	ST	
RA6	14	11	20	17	I/O	ST	
RA7	—	—	19	16	I/O	ST	
RB0	4	1	4	1	I/O	ST	PORTB Digital I/O
RB1	5	2	5	2	I/O	ST	
RB2	6	3	6	3	I/O	ST	
RB3	—	—	7	4	I/O	ST	
RB4	9	6	11	8	I/O	ST	
RB5	—	—	14	11	I/O	ST	
RB6	—	—	15	12	I/O	ST	
RB7	11	8	16	13	I/O	ST	
RB8	12	9	17	14	I/O	ST	
RB9	13	10	18	15	I/O	ST	
RB10	—	—	21	18	I/O	ST	
RB11	—	—	22	19	I/O	ST	
RB12	15	12	23	20	I/O	ST	
RB13	16	13	24	21	I/O	ST	
RB14	17	14	25	22	I/O	ST	
RB15	18	15	26	23	I/O	ST	
REFO	18	15	26	23	O	—	Reference Clock Output
RTCC	17	14	25	22	O	—	Real-Time Clock Alarm Output
SCK1	15	12	22	19	I/O	ST	SPI1 Serial Clock Input/Output
SCL1	12	9	17, 15 <sup>(1)</sup>	14, 12 <sup>(1)</sup>	I/O	I <sup>2</sup> C	I <sup>2</sup> C1 Synchronous Serial Clock Input/Output
SDA1	13	10	18, 14 <sup>(1)</sup>	15, 11 <sup>(1)</sup>	I/O	I <sup>2</sup> C	I <sup>2</sup> C1 Data Input/Output
SDI1	17	14	21	18	I	ST	SPI1 Serial Data Input
SDO1	16	13	24	21	O	—	SPI1 Serial Data Output
SOSCI	9	6	11	8	I	ANA	Secondary Oscillator Input
SOSCO	10	7	12	9	O	ANA	Secondary Oscillator Output
SS1	18	15	26	23	I/O	ST	Slave Select Input/Frame Select Output (SPI1)

**Legend:** ST = Schmitt Trigger input buffer, ANA = Analog level input/output, I<sup>2</sup>C™ = I<sup>2</sup>C/SMBus input buffer

**Note 1:** Alternative multiplexing when the I2C1SEL Configuration bit is cleared.

# PIC24F16KA102 FAMILY

**TABLE 1-2: PIC24F16KA102 FAMILY PINOUT DESCRIPTIONS (CONTINUED)**

Function	Pin Number				I/O	Input Buffer	Description
	20-Pin PDIP/SSOP/SOIC	20-Pin QFN	28-Pin SPDIP/SSOP/SOIC	28-Pin QFN			
T1CK	10	7	12	9	I	ST	Timer1 Clock
T2CK	18	15	26	23	I	ST	Timer2 Clock
T3CK	18	15	26	23	I	ST	Timer3 Clock
U1CTS	12	9	17	14	I	ST	UART1 Clear to Send Input
U1RTS	13	10	18	15	O	—	UART1 Request to Send Output
U1RX	6	3	6	3	I	ST	UART1 Receive
U1TX	11	8	16	13	O	—	UART1 Transmit Output
VDD	20	17	13, 28	10, 25	P	—	Positive Supply for Peripheral Digital Logic and I/O Pins
VPP	1	18	1	26	P	—	Programming Mode Entry Voltage
VREF-	3	20	3	28	I	ANA	A/D and Comparator Reference Voltage (low) Input
VREF+	2	19	2	27	I	ANA	A/D and Comparator Reference Voltage (high) Input
VSS	19	16	8, 27	5, 24	P	—	Ground Reference for Logic and I/O Pin

**Legend:** ST = Schmitt Trigger input buffer, ANA = Analog level input/output, I<sup>2</sup>C™ = I<sup>2</sup>C/SMBus input buffer

**Note 1:** Alternative multiplexing when the I2C1SEL Configuration bit is cleared.



# PIC24F16KA102 FAMILY

## 2.0 GUIDELINES FOR GETTING STARTED WITH 16-BIT MICROCONTROLLERS

### 2.1 Basic Connection Requirements

Getting started with the PIC24F16KA102 family of 16-bit microcontrollers requires attention to a minimal set of device pin connections before proceeding with development.

The following pins must always be connected:

- All VDD and VSS pins (see [Section 2.2 “Power Supply Pins”](#))
- All AVDD and AVSS pins, regardless of whether or not the analog device features are used (see [Section 2.2 “Power Supply Pins”](#))
- MCLR pin (see [Section 2.3 “Master Clear \(MCLR\) Pin”](#))
- VCAP pins (see [Section 2.4 “Voltage Regulator Pin \(VCAP\)”](#))

These pins must also be connected if they are being used in the end application:

- PGECx/PGEDx pins used for In-Circuit Serial Programming™ (ICSP™) and debugging purposes (see [Section 2.5 “ICSP Pins”](#))
- OSCI and OSCO pins when an external oscillator source is used (see [Section 2.6 “External Oscillator Pins”](#))

Additionally, the following pins may be required:

- VREF+/VREF- pins are used when external voltage reference for analog modules is implemented

**Note:** The AVDD and AVSS pins must always be connected, regardless of whether any of the analog modules are being used.

The minimum mandatory connections are shown in [Figure 2-1](#).

FIGURE 2-1: RECOMMENDED MINIMUM CONNECTIONS



# PIC24F16KA102 FAMILY

## 2.2 Power Supply Pins

### 2.2.1 DECOUPLING CAPACITORS

The use of decoupling capacitors on every pair of power supply pins, such as VDD, VSS, AVDD and AVSS, is required.

Consider the following criteria when using decoupling capacitors:

- **Value and type of capacitor:** A 0.1  $\mu\text{F}$  (100 nF), 10-20V capacitor is recommended. The capacitor should be a low-ESR device, with a resonance frequency in the range of 200 MHz and higher. Ceramic capacitors are recommended.
- **Placement on the printed circuit board:** The decoupling capacitors should be placed as close to the pins as possible. It is recommended to place the capacitors on the same side of the board as the device. If space is constricted, the capacitor can be placed on another layer on the PCB using a via; however, ensure that the trace length from the pin to the capacitor is no greater than 0.25 inch (6 mm).
- **Handling high-frequency noise:** If the board is experiencing high-frequency noise (upward of tens of MHz), add a second ceramic type capacitor in parallel to the above described decoupling capacitor. The value of the second capacitor can be in the range of 0.01  $\mu\text{F}$  to 0.001  $\mu\text{F}$ . Place this second capacitor next to each primary decoupling capacitor. In high-speed circuit designs, consider implementing a decade pair of capacitances as close to the power and ground pins as possible (e.g., 0.1  $\mu\text{F}$  in parallel with 0.001  $\mu\text{F}$ ).
- **Maximizing performance:** On the board layout from the power supply circuit, run the power and return traces to the decoupling capacitors first, and then to the device pins. This ensures that the decoupling capacitors are first in the power chain. Equally important is to keep the trace length between the capacitor and the power pins to a minimum, thereby reducing PCB trace inductance.

### 2.2.2 TANK CAPACITORS

On boards with power traces running longer than six inches in length, it is suggested to use a tank capacitor for integrated circuits, including microcontrollers, to supply a local power source. The value of the tank capacitor should be determined based on the trace resistance that connects the power supply source to the device, and the maximum current drawn by the device in the application. In other words, select the tank capacitor so that it meets the acceptable voltage sag at the device. Typical values range from 4.7  $\mu\text{F}$  to 47  $\mu\text{F}$ .

## 2.3 Master Clear ( $\overline{\text{MCLR}}$ ) Pin

The  $\overline{\text{MCLR}}$  pin provides two specific device functions: Device Reset, and Device Programming and Debugging. If programming and debugging are not required in the end application, a direct connection to VDD may be all that is required. The addition of other components, to help increase the application's resistance to spurious Resets from voltage sags, may be beneficial. A typical configuration is shown in Figure 2-1. Other circuit designs may be implemented, depending on the application's requirements.

During programming and debugging, the resistance and capacitance that can be added to the pin must be considered. Device programmers and debuggers drive the  $\overline{\text{MCLR}}$  pin. Consequently, specific voltage levels ( $V_{IH}$  and  $V_{IL}$ ) and fast signal transitions must not be adversely affected. Therefore, specific values of R1 and C1 will need to be adjusted based on the application and PCB requirements. For example, it is recommended that the capacitor, C1, be isolated from the  $\overline{\text{MCLR}}$  pin during programming and debugging operations by using a jumper (Figure 2-2). The jumper is replaced for normal run-time operations.

Any components associated with the  $\overline{\text{MCLR}}$  pin should be placed within 0.25 inch (6 mm) of the pin.

**FIGURE 2-2: EXAMPLE OF  $\overline{\text{MCLR}}$  PIN CONNECTIONS**

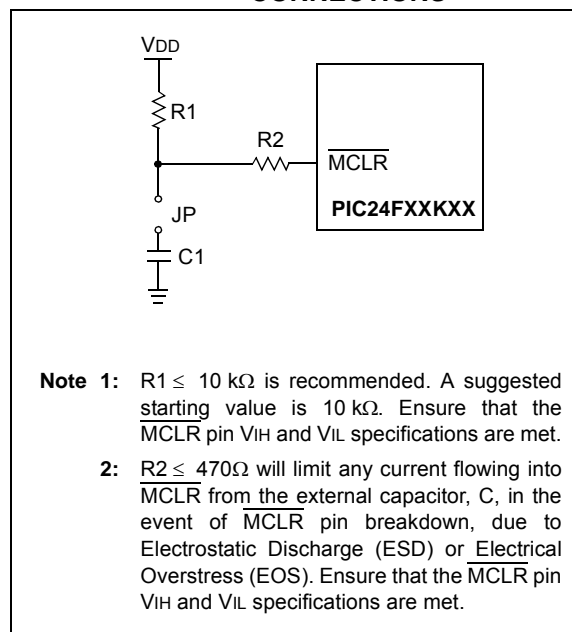

# PIC24F16KA102 FAMILY

## 2.4 Voltage Regulator Pin (VCAP)

**Note:** This section applies only to PIC24F K devices with an on-chip voltage regulator.

Some of the PIC24F K devices have an internal voltage regulator. These devices have the voltage regulator output brought out on the VCAP pin. On the PIC24F K devices with regulators, a low-ESR ( $< 5\Omega$ ) capacitor is required on the VCAP pin to stabilize the voltage regulator output. The VCAP pin must not be connected to VDD and must use a capacitor of 10  $\mu\text{F}$  connected to ground. The type can be ceramic or tantalum. Suitable examples of capacitors are shown in Table 2-1. Capacitors with equivalent specifications can be used.

Designers may use Figure 2-3 to evaluate ESR equivalence of candidate devices.

The placement of this capacitor should be close to VCAP. It is recommended that the trace length not exceed 0.25 inch (6 mm). Refer to Section 29.0 “Electrical Characteristics” for additional information.

Refer to Section 29.0 “Electrical Characteristics” for information on VDD and VDDCORE.

**FIGURE 2-3: FREQUENCY vs. ESR PERFORMANCE FOR SUGGESTED VCAP**



**TABLE 2-1: SUITABLE CAPACITOR EQUIVALENTS**

Make	Part #	Nominal Capacitance	Base Tolerance	Rated Voltage	Temp. Range
TDK	C3216X7R1C106K	10 $\mu\text{F}$	$\pm 10\%$	16V	-55 to 125°C
TDK	C3216X5R1C106K	10 $\mu\text{F}$	$\pm 10\%$	16V	-55 to 85°C
Panasonic	ECJ-3YX1C106K	10 $\mu\text{F}$	$\pm 10\%$	16V	-55 to 125°C
Panasonic	ECJ-4YB1C106K	10 $\mu\text{F}$	$\pm 10\%$	16V	-55 to 85°C
Murata	GRM32DR71C106KA01L	10 $\mu\text{F}$	$\pm 10\%$	16V	-55 to 125°C
Murata	GRM31CR61C106KC31L	10 $\mu\text{F}$	$\pm 10\%$	16V	-55 to 85°C

# PIC24F16KA102 FAMILY

## 2.4.1 CONSIDERATIONS FOR CERAMIC CAPACITORS

In recent years, large value, low-voltage, surface-mount ceramic capacitors have become very cost effective in sizes up to a few tens of microfarad. The low-ESR, small physical size and other properties make ceramic capacitors very attractive in many types of applications.

Ceramic capacitors are suitable for use with the internal voltage regulator of this microcontroller. However, some care is needed in selecting the capacitor to ensure that it maintains sufficient capacitance over the intended operating range of the application.

Typical low-cost, 10  $\mu$ F ceramic capacitors are available in X5R, X7R and Y5V dielectric ratings (other types are also available, but are less common). The initial tolerance specifications for these types of capacitors are often specified as  $\pm 10\%$  to  $\pm 20\%$  (X5R and X7R), or  $-20\%/+80\%$  (Y5V). However, the effective capacitance that these capacitors provide in an application circuit will also vary based on additional factors, such as the applied DC bias voltage and the temperature. The total in-circuit tolerance is, therefore, much wider than the initial tolerance specification.

The X5R and X7R capacitors typically exhibit satisfactory temperature stability (ex:  $\pm 15\%$  over a wide temperature range, but consult the manufacturer's data sheets for exact specifications). However, Y5V capacitors typically have extreme temperature tolerance specifications of  $+22\%/ -82\%$ . Due to the extreme temperature tolerance, a 10  $\mu$ F nominal rated Y5V type capacitor may not deliver enough total capacitance to meet minimum internal voltage regulator stability and transient response requirements. Therefore, Y5V capacitors are not recommended for use with the internal regulator if the application must operate over a wide temperature range.

In addition to temperature tolerance, the effective capacitance of large value ceramic capacitors can vary substantially, based on the amount of DC voltage applied to the capacitor. This effect can be very significant, but is often overlooked or is not always documented.

A typical DC bias voltage vs. capacitance graph for X7R type capacitors is shown in [Figure 2-4](#).

**FIGURE 2-4: DC BIAS VOLTAGE vs. CAPACITANCE CHARACTERISTICS**



When selecting a ceramic capacitor to be used with the internal voltage regulator, it is suggested to select a high-voltage rating, so that the operating voltage is a small percentage of the maximum rated capacitor voltage. For example, choose a ceramic capacitor rated at 16V for the 3.3V or 2.5V core voltage. Suggested capacitors are shown in [Table 2-1](#).

## 2.5 ICSP Pins

The PGC and PGD pins are used for In-Circuit Serial Programming™ (ICSP™) and debugging purposes. It is recommended to keep the trace length between the ICSP connector and the ICSP pins on the device as short as possible. If the ICSP connector is expected to experience an ESD event, a series resistor is recommended, with the value in the range of a few tens of ohms, not to exceed 100 $\Omega$ .

Pull-up resistors, series diodes and capacitors on the PGC and PGD pins are not recommended as they will interfere with the programmer/debugger communications to the device. If such discrete components are an application requirement, they should be removed from the circuit during programming and debugging. Alternatively, refer to the AC/DC characteristics and timing requirements information in the respective device Flash programming specification for information on capacitive loading limits, and pin input voltage high ( $V_{IH}$ ) and input low ( $V_{IL}$ ) requirements.

For device emulation, ensure that the “Communication Channel Select” (i.e., PGCx/PGDx pins), programmed into the device, matches the physical connections for the ICSP to the Microchip debugger/emulator tool.

For more information on available Microchip development tools connection requirements, refer to [Section 27.0 “Development Support”](#).

## 2.6 External Oscillator Pins

Many microcontrollers have options for at least two oscillators: a high-frequency primary oscillator and a low-frequency secondary oscillator (refer to [Section 9.0 “Oscillator Configuration”](#) for details).

The oscillator circuit should be placed on the same side of the board as the device. Place the oscillator circuit close to the respective oscillator pins with no more than 0.5 inch (12 mm) between the circuit components and the pins. The load capacitors should be placed next to the oscillator itself, on the same side of the board.

Use a grounded copper pour around the oscillator circuit to isolate it from surrounding circuits. The grounded copper pour should be routed directly to the MCU ground. Do not run any signal traces or power traces inside the ground pour. Also, if using a two-sided board, avoid any traces on the other side of the board where the crystal is placed.

Layout suggestions are shown in [Figure 2-5](#). In-line packages may be handled with a single-sided layout that completely encompasses the oscillator pins. With fine-pitch packages, it is not always possible to completely surround the pins and components. A suitable solution is to tie the broken guard sections to a mirrored ground layer. In all cases, the guard trace(s) must be returned to ground.

In planning the application’s routing and I/O assignments, ensure that adjacent port pins and other signals, in close proximity to the oscillator, are benign (i.e., free of high frequencies, short rise and fall times, and other similar noise).

For additional information and design guidance on oscillator circuits, please refer to these Microchip Application Notes, available at the corporate web site ([www.microchip.com](http://www.microchip.com)):

- AN826, “Crystal Oscillator Basics and Crystal Selection for rPIC™ and PICmicro® Devices”
- AN849, “Basic PICmicro® Oscillator Design”
- AN943, “Practical PICmicro® Oscillator Analysis and Design”
- AN949, “Making Your Oscillator Work”

## 2.7 Unused I/Os

Unused I/O pins should be configured as outputs and driven to a logic low state. Alternatively, connect a 1 kΩ to 10 kΩ resistor to Vss on unused pins and drive the output to logic low.

**FIGURE 2-5: SUGGESTED PLACEMENT OF THE OSCILLATOR CIRCUIT**



# PIC24F16KA102 FAMILY

---

NOTES:

## 3.0 CPU

**Note:** This data sheet summarizes the features of this group of PIC24F devices. It is not intended to be a comprehensive reference source. For more information on the CPU, refer to the “PIC24F Family Reference Manual”, **Section 2. “CPU”** (DS39703).

The PIC24F CPU has a 16-bit (data) modified Harvard architecture with an enhanced instruction set and a 24-bit instruction word with a variable length opcode field. The Program Counter (PC) is 23 bits wide and addresses up to 4M instructions of user program memory space. A single-cycle instruction prefetch mechanism is used to help maintain throughput and provides predictable execution. All instructions execute in a single cycle, with the exception of instructions that change the program flow, the double-word move (MOV.D) instruction and the table instructions. Overhead-free program loop constructs are supported using the REPEAT instructions, which are interruptible at any point.

PIC24F devices have sixteen, 16-bit working registers in the programmer's model. Each of the working registers can act as a data, address or address offset register. The 16<sup>th</sup> working register (W15) operates as a Software Stack Pointer (SSP) for interrupts and calls.

The upper 32 Kbytes of the data space memory map can optionally be mapped into program space at any 16K word boundary of either program memory or data EEPROM memory defined by the 8-bit Program Space Visibility Page Address (PSVPAG) register. The program to data space mapping feature lets any instruction access program space as if it were data space.

The Instruction Set Architecture (ISA) has been significantly enhanced beyond that of the PIC18, but maintains an acceptable level of backward compatibility. All PIC18 instructions and addressing modes are supported, either directly, or through simple macros. Many of the ISA enhancements have been driven by compiler efficiency needs.

The core supports Inherent (no operand), Relative, Literal, Memory Direct and three groups of addressing modes. All modes support Register Direct and various Register Indirect modes. Each group offers up to seven addressing modes. Instructions are associated with predefined addressing modes depending upon their functional requirements.

For most instructions, the core is capable of executing a data (or program data) memory read, a working register (data) read, a data memory write and a program (instruction) memory read per instruction cycle. As a result, three parameter instructions can be supported, allowing trinary operations (that is,  $A + B = C$ ) to be executed in a single cycle.

A high-speed, 17-bit by 17-bit multiplier has been included to significantly enhance the core arithmetic capability and throughput. The multiplier supports Signed, Unsigned and Mixed mode, 16-bit by 16-bit or 8-bit by 8-bit integer multiplication. All multiply instructions execute in a single cycle.

The 16-bit ALU has been enhanced with integer divide assist hardware that supports an iterative non-restoring divide algorithm. It operates in conjunction with the REPEAT instruction looping mechanism and a selection of iterative divide instructions to support 32-bit (or 16-bit), divided by 16-bit integer signed and unsigned division. All divide operations require 19 cycles to complete but are interruptible at any cycle boundary.

The PIC24F has a vectored exception scheme with up to eight sources of non-maskable traps and up to 118 interrupt sources. Each interrupt source can be assigned to one of seven priority levels.

A block diagram of the CPU is illustrated in [Figure 3-1](#).

### 3.1 Programmer's Model

[Figure 3-2](#) displays the programmer's model for the PIC24F. All registers in the programmer's model are memory mapped and can be manipulated directly by instructions.

[Table 3-1](#) provides a description of each register. All registers associated with the programmer's model are memory mapped.

# PIC24F16KA102 FAMILY

**FIGURE 3-1: PIC24F CPU CORE BLOCK DIAGRAM**



**TABLE 3-1: CPU CORE REGISTERS**

Register(s) Name	Description
W0 through W15	Working Register Array
PC	23-Bit Program Counter
SR	ALU STATUS Register
SPLIM	Stack Pointer Limit Value Register
TBLPAG	Table Memory Page Address Register
PSVPAG	Program Space Visibility Page Address Register
RCOUNT	Repeat Loop Counter Register
CORCON	CPU Control Register



# PIC24F16KA102 FAMILY

**FIGURE 3-2: PROGRAMMER'S MODEL**



# PIC24F16KA102 FAMILY

## 3.2 CPU Control Registers

**REGISTER 3-1: SR: ALU STATUS REGISTER**

U-0	U-0	U-0	U-0	U-0	U-0	U-0	R/W-0, HSC
—	—	—	—	—	—	—	DC
bit 15							bit 8

R/W-0, HSC <sup>(1)</sup>	R/W-0, HSC <sup>(1)</sup>	R/W-0, HSC <sup>(1)</sup>	R-0, HSC	R/W-0, HSC	R/W-0, HSC	R/W-0, HSC	R/W-0, HSC
IPL2 <sup>(2)</sup>	IPL1 <sup>(2)</sup>	IPL0 <sup>(2)</sup>	RA	N	OV	Z	C
bit 7							bit 0

<b>Legend:</b>	HSC = Hardware Settable/Clearable bit
R = Readable bit	W = Writable bit
-n = Value at POR	'1' = Bit is set
	U = Unimplemented bit, read as '0'
	'0' = Bit is cleared
	x = Bit is unknown

- bit 15-9     **Unimplemented:** Read as '0'
- bit 8       **DC:** ALU Half Carry/Borrow bit
  - 1 = A carry-out from the 4<sup>th</sup> low-order bit (for byte-sized data) or 8<sup>th</sup> low-order bit (for word-sized data) of the result occurred
  - 0 = No carry-out from the 4<sup>th</sup> or 8<sup>th</sup> low-order bit of the result has occurred
- bit 7-5     **IPL<2:0>:** CPU Interrupt Priority Level Status bits<sup>(1,2)</sup>
  - 111 = CPU interrupt priority level is 7 (15); user interrupts disabled
  - 110 = CPU interrupt priority level is 6 (14)
  - 101 = CPU Interrupt priority level is 5 (13)
  - 100 = CPU interrupt priority level is 4 (12)
  - 011 = CPU interrupt priority level is 3 (11)
  - 010 = CPU interrupt priority level is 2 (10)
  - 001 = CPU interrupt priority level is 1 (9)
  - 000 = CPU interrupt priority level is 0 (8)
- bit 4       **RA:** REPEAT Loop Active bit
  - 1 = REPEAT loop in progress
  - 0 = REPEAT loop not in progress
- bit 3       **N:** ALU Negative bit
  - 1 = Result was negative
  - 0 = Result was non-negative (zero or positive)
- bit 2       **OV:** ALU Overflow bit
  - 1 = Overflow occurred for signed (2's complement) arithmetic in this arithmetic operation
  - 0 = No overflow has occurred
- bit 1       **Z:** ALU Zero bit
  - 1 = An operation, which effects the Z bit, has set it at some time in the past
  - 0 = The most recent operation, which effects the Z bit, has cleared it (i.e., a non-zero result)
- bit 0       **C:** ALU Carry/Borrow bit
  - 1 = A carry-out from the Most Significant bit (MSb) of the result occurred
  - 0 = No carry-out from the Most Significant bit (MSb) of the result occurred

- Note 1:** The IPL Status bits are read-only when NSTDIS (INTCON1<15>) = 1.
- Note 2:** The IPL Status bits are concatenated with the IPL3 bit (CORCON<3>) to form the CPU Interrupt Priority Level (IPL). The value in parentheses indicates the IPL when IPL3 = 1.

# PIC24F16KA102 FAMILY

## REGISTER 3-2: CORCON: CPU CONTROL REGISTER

U-0	U-0	U-0	U-0	U-0	U-0	U-0	U-0
—	—	—	—	—	—	—	—
bit 15							bit 8

U-0	U-0	U-0	U-0	R/C-0, HSC	R/W-0	U-0	U-0
—	—	—	—	IPL3 <sup>(1)</sup>	PSV	—	—
bit 7							bit 0

<b>Legend:</b>	HSC = Hardware Settable/Clearable bit		
R = Readable bit	W = Writable bit	U = Unimplemented bit, read as '0'	
-n = Value at POR	'1' = Bit is set	'0' = Bit is cleared	x = Bit is unknown

- bit 15-4     **Unimplemented:** Read as '0'
- bit 3        **IPL3:** CPU Interrupt Priority Level Status bit<sup>(1)</sup>  
               1 = CPU interrupt priority level is greater than 7  
               0 = CPU interrupt priority level is 7 or less
- bit 2        **PSV:** Program Space Visibility in Data Space Enable bit  
               1 = Program space is visible in data space  
               0 = Program space is not visible in data space
- bit 1-0     **Unimplemented:** Read as '0'

**Note 1:** User interrupts are disabled when IPL3 = 1.

### 3.3 Arithmetic Logic Unit (ALU)

The PIC24F ALU is 16 bits wide and is capable of addition, subtraction, bit shifts and logic operations. Unless otherwise mentioned, arithmetic operations are 2's complement in nature. Depending on the operation, the ALU may affect the values of the Carry (C), Zero (Z), Negative (N), Overflow (OV) and Digit Carry (DC) Status bits in the SR register. The C and DC Status bits operate as Borrow and Digit Borrow bits, respectively, for subtraction operations.

The ALU can perform 8-bit or 16-bit operations, depending on the mode of the instruction that is used. Data for the ALU operation can come from the W register array, or data memory, depending on the addressing mode of the instruction. Likewise, output data from the ALU can be written to the W register array or a data memory location.

The PIC24F CPU incorporates hardware support for both multiplication and division. This includes a dedicated hardware multiplier and support hardware division for 16-bit divisor.

#### 3.3.1 MULTIPLIER

The ALU contains a high-speed, 17-bit x 17-bit multiplier. It supports unsigned, signed or mixed sign operation in several multiplication modes:

- 16-bit x 16-bit signed
- 16-bit x 16-bit unsigned
- 16-bit signed x 5-bit (literal) unsigned
- 16-bit unsigned x 16-bit unsigned
- 16-bit unsigned x 5-bit (literal) unsigned
- 16-bit unsigned x 16-bit signed
- 8-bit unsigned x 8-bit unsigned

# PIC24F16KA102 FAMILY

---

## 3.3.2 DIVIDER

The divide block supports 32-bit/16-bit and 16-bit/16-bit signed and unsigned integer divide operations with the following data sizes:

1. 32-bit signed/16-bit signed divide
2. 32-bit unsigned/16-bit unsigned divide
3. 16-bit signed/16-bit signed divide
4. 16-bit unsigned/16-bit unsigned divide

The quotient for all divide instructions ends up in W0 and the remainder in W1. Sixteen-bit signed and unsigned DIV instructions can specify any W register for both the 16-bit divisor (Wn), and any W register (aligned) pair (W(m + 1):Wm) for the 32-bit dividend. The divide algorithm takes one cycle per bit of divisor, so both 32-bit/16-bit and 16-bit/16-bit instructions take the same number of cycles to execute.

## 3.3.3 MULTI-BIT SHIFT SUPPORT

The PIC24F ALU supports both single bit and single-cycle, multi-bit arithmetic and logic shifts. Multi-bit shifts are implemented using a shifter block, capable of performing up to a 15-bit arithmetic right shift, or up to a 15-bit left shift, in a single cycle. All multi-bit shift instructions only support Register Direct Addressing for both the operand source and result destination.

A full summary of instructions that use the shift operation is provided below in [Table 3-2](#).

**TABLE 3-2: INSTRUCTIONS THAT USE THE SINGLE AND MULTI-BIT SHIFT OPERATION**

Instruction	Description
ASR	Arithmetic shift right source register by one or more bits.
SL	Shift left source register by one or more bits.
LSR	Logical shift right source register by one or more bits.

# PIC24F16KA102 FAMILY

## 4.0 MEMORY ORGANIZATION

As with Harvard architecture devices, the PIC24F microcontrollers feature separate program and data memory space and busing. This architecture also allows the direct access of program memory from the data space during code execution.

### 4.1 Program Address Space

The program address memory space of the PIC24F devices is 4M instructions. The space is addressable by a 24-bit value derived from either the 23-bit Program Counter (PC) during program execution, or from a table operation or data space remapping, as described in [Section 4.3 “Interfacing Program and Data Memory Spaces”](#).

The user access to the program memory space is restricted to the lower half of the address range (000000h to 7FFFFFFh). The exception is the use of TBLRD/TBLWT operations, which use TBLPAG<7> to permit access to the Configuration bits and Device ID sections of the configuration memory space.

Memory maps for the PIC24F16KA102 family of devices are displayed in [Figure 4-1](#).

**FIGURE 4-1: PROGRAM SPACE MEMORY MAP FOR PIC24F16KA102 FAMILY DEVICES**



# PIC24F16KA102 FAMILY

## 4.1.1 PROGRAM MEMORY ORGANIZATION

The program memory space is organized in word-addressable blocks. Although it is treated as 24 bits wide, it is more appropriate to think of each address of the program memory as a lower and upper word, with the upper byte of the upper word being unimplemented. The lower word always has an even address, while the upper word has an odd address (Figure 4-2).

Program memory addresses are always word-aligned on the lower word, and addresses are incremented or decremented by two during code execution. This arrangement also provides compatibility with data memory space addressing and makes it possible to access data in the program memory space.

## 4.1.2 HARD MEMORY VECTORS

All PIC24F devices reserve the addresses between 00000h and 000200h for hard coded program execution vectors. A hardware Reset vector is provided to redirect code execution from the default value of the PC on device Reset to the actual start of code. A GOTO instruction is programmed by the user at 000000h with the actual address for the start of code at 000002h.

PIC24F devices also have two Interrupt Vector Tables, located from 000004h to 0000FFh, and 000104h to 0001FFh. These vector tables allow each of the many device interrupt sources to be handled by separate ISRs. Section 8.1 “Interrupt Vector (IVT) Table” discusses the Interrupt Vector Tables in more detail.

## 4.1.3 DATA EEPROM

In the PIC24F16KA102 family, the data EEPROM is mapped to the top of the user program memory space, starting at address, 7FFE00, and expanding up to address, 7FFFFF.

The data EEPROM is organized as 16-bit wide memory and 256 words deep. This memory is accessed using table read and write operations similar to the user code memory.

## 4.1.4 DEVICE CONFIGURATION WORDS

Table 4-1 provides the addresses of the device Configuration Words for the PIC24F16KA102 family. Their location in the memory map is displayed in Figure 4-1.

Refer to Section 26.1 “Configuration Bits” for more information on device Configuration Words.

**TABLE 4-1: DEVICE CONFIGURATION WORDS FOR PIC24F16KA102 FAMILY DEVICES**

Configuration Word	Configuration Word Addresses
FBS	F80000
FGS	F80004
FOSCSEL	F80006
FOSC	F80008
FWDT	F8000A
FPOR	F8000C
FICD	F8000E
FDS	F80010

**FIGURE 4-2: PROGRAM MEMORY ORGANIZATION**



# PIC24F16KA102 FAMILY

## 4.2 Data Address Space

The PIC24F core has a separate, 16-bit wide data memory space, addressable as a single linear range. The data space is accessed using two Address Generation Units (AGUs), one each for read and write operations. The data space memory map is displayed in Figure 4-3.

All Effective Addresses (EAs) in the data memory space are 16 bits wide and point to bytes within the data space. This gives a data space address range of 64 Kbytes or 32K words. The lower half of the data memory space (that is, when  $EA<15> = 0$ ) is used for implemented memory addresses, while the upper half ( $EA<15> = 1$ ) is reserved for the Program Space Visibility (PSV) area (see Section 4.3.3 “Reading Data From Program Memory Using Program Space Visibility”).

PIC24F16KA102 family devices implement a total of 768 words of data memory. Should an EA point to a location outside of this area, an all zero word or byte will be returned.

### 4.2.1 DATA SPACE WIDTH

The data memory space is organized in byte-addressable, 16-bit wide blocks. Data is aligned in data memory and registers as 16-bit words, but all the data space EAs resolve to bytes. The Least Significant Bytes (LSBs) of each word have even addresses, while the Most Significant Bytes (MSBs) have odd addresses.

**FIGURE 4-3: DATA SPACE MEMORY MAP FOR PIC24F16KA102 FAMILY DEVICES**

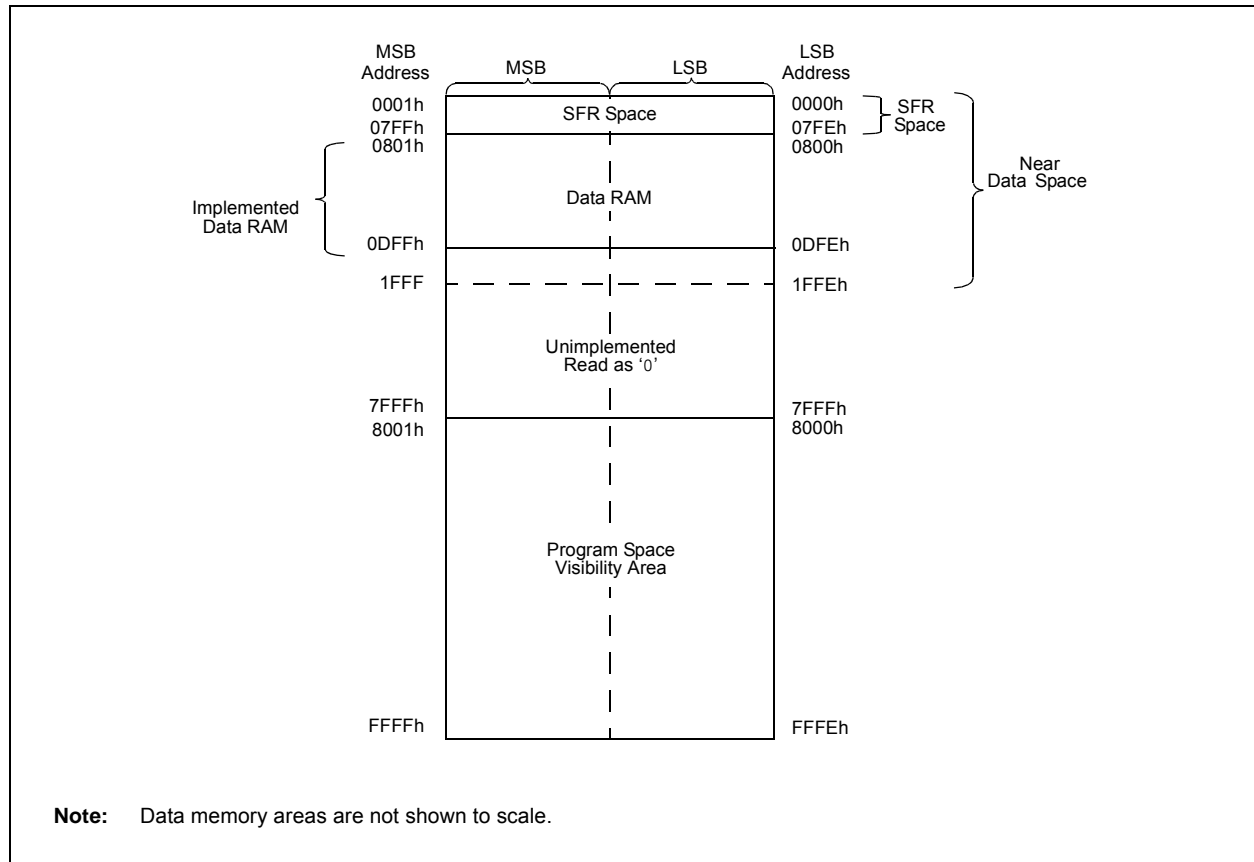

# PIC24F16KA102 FAMILY

## 4.2.2 DATA MEMORY ORGANIZATION AND ALIGNMENT

To maintain backward compatibility with PIC® devices and improve data space memory usage efficiency, the PIC24F instruction set supports both word and byte operations. As a consequence of byte accessibility, all EA calculations are internally scaled to step through word-aligned memory. For example, the core recognizes that Post-Modified Register Indirect Addressing mode [Ws++] will result in a value of Ws + 1 for byte operations and Ws + 2 for word operations.

Data byte reads will read the complete word, which contains the byte, using the LSB of any EA to determine which byte to select. The selected byte is placed onto the LSB of the data path. That is, the data memory and the registers are organized as two parallel, byte-wide entities with shared (word) address decode, but separate write lines. Data byte writes only write to the corresponding side of the array or register, which matches the byte address.

All word accesses must be aligned to an even address. Misaligned word data fetches are not supported, so care must be taken when mixing byte and word operations, or translating from 8-bit MCU code. If a misaligned read or write is attempted, an address error trap will be generated. If the error occurred on a read, the instruction underway is completed; if it occurred on a write, the instruction will be executed, but the write will not occur. In either case, a trap is then executed, allowing the system and/or user to examine the machine state prior to execution of the address Fault.

All byte loads into any W register are loaded into the LSB; the MSB is not modified.

A Sign-Extend instruction (SE) is provided to allow the users to translate 8-bit signed data to 16-bit signed values. Alternatively, for 16-bit unsigned data, users can clear the MSB of any W register by executing a Zero-Extend (ZE) instruction on the appropriate address.

Although most instructions are capable of operating on word or byte data sizes, it should be noted that some instructions operate only on words.

## 4.2.3 NEAR DATA SPACE

The 8-Kbyte area between 0000h and 1FFFh is referred to as the Near Data Space. Locations in this space are directly addressable via a 13-bit absolute address field within all memory direct instructions. The remainder of the data space is addressable indirectly. Additionally, the whole data space is addressable using MOV instructions, which support Memory Direct Addressing (MDA) with a 16-bit address field. For PIC24F16KA102 family devices, the entire implemented data memory lies in Near Data Space (NDS).

## 4.2.4 SFR SPACE

The first 2 Kbytes of the Near Data Space, from 0000h to 07FFh, are primarily occupied with Special Function Registers (SFRs). These are used by the PIC24F core and peripheral modules for controlling the operation of the device.

SFRs are distributed among the modules that they control and are generally grouped together by that module. Much of the SFR space contains unused addresses; these are read as '0'. The SFR space, where the SFRs are actually implemented, is provided in Table 4-2. Each implemented area indicates a 32-byte region where at least one address is implemented as an SFR. A complete listing of implemented SFRs, including their addresses, is provided in Table 4-3 through Table 4-23.

**TABLE 4-2: IMPLEMENTED REGIONS OF SFR DATA SPACE**

	SFR Space Address							
	xx00	xx20	xx40	xx60	xx80	xxA0	xxC0	xxE0
000h	Core			ICN	Interrupts			—
100h	Timers		Capture	—	Compare	—	—	—
200h	I <sup>2</sup> C™	UART	SPI		—	—	I/O	
300h	A/D/CMTU		—	—	—	—	—	—
400h	—	—	—	—	—	—	—	—
500h	—	—	—	—	—	—	—	—
600h	—	RTC/Comp	CRC	—	—			—
700h	—	—	System/DS/HLVD	NVM/PMD	—	—	—	—

**Legend:** — = No implemented SFRs in this block.



**TABLE 4-3: CPU CORE REGISTERS MAP**

File Name	Addr	Bit 15	Bit 14	Bit 13	Bit 12	Bit 11	Bit 10	Bit 9	Bit 8	Bit 7	Bit 6	Bit 5	Bit 4	Bit 3	Bit 2	Bit 1	Bit 0	All Resets
WREG0	0000	Working Register 0																0000
WREG1	0002	Working Register 1																0000
WREG2	0004	Working Register 2																0000
WREG3	0006	Working Register 3																0000
WREG4	0008	Working Register 4																0000
WREG5	000A	Working Register 5																0000
WREG6	000C	Working Register 6																0000
WREG7	000E	Working Register 7																0000
WREG8	0010	Working Register 8																0000
WREG9	0012	Working Register 9																0000
WREG10	0014	Working Register 10																0000
WREG11	0016	Working Register 11																0000
WREG12	0018	Working Register 12																0000
WREG13	001A	Working Register 13																0000
WREG14	001C	Working Register 14																0000
WREG15	001E	Working Register 15																0800
SPLIM	0020	Stack Pointer Limit Value Register																xxxx
PCL	002E	Program Counter Low Byte Register																0000
PCH	0030	—	—	—	—	—	—	—	—	Program Counter Register High Byte							0000	
TBLPAG	0032	—	—	—	—	—	—	—	—	Table Memory Page Address Register							0000	
PSVPAG	0034	—	—	—	—	—	—	—	—	Program Space Visibility Page Address Register							0000	
RCOUNT	0036	REPEAT Loop Counter Register																xxxx
SR	0042	—	—	—	—	—	—	—	DC	IPL2	IPL1	IPL0	RA	N	OV	Z	C	0000
CORCON	0044	—	—	—	—	—	—	—	—	—	—	—	—	IPL3	PSV	—	—	0000
DISICNT	0052	—	—	Disable Interrupts Counter Register													xxxx	

**Legend:** — = unimplemented, read as '0'. Reset values are shown in hexadecimal.

TABLE 4-4: ICN REGISTER MAP

File Name	Addr	Bit 15	Bit 14	Bit 13	Bit 12	Bit 11	Bit 10	Bit 9	Bit 8	Bit 7	Bit 6	Bit 5	Bit 4	Bit 3	Bit 2	Bit 1	Bit 0	All Resets
CNEN1	0060	CN15IE <sup>(1)</sup>	CN14IE	CN13IE	CN12IE	CN11IE <sup>(1)</sup>	—	CN9IE	CN8IE	CN7IE <sup>(1)</sup>	CN6IE	CN5IE	CN4IE	CN3IE	CN2IE	CN1IE	CN0IE	0000
CNEN2	0062	—	CN30IE	CN29IE	—	CN27IE <sup>(1)</sup>	—	—	CN24IE <sup>(1)</sup>	CN23IE	CN22IE	CN21IE	—	—	—	—	CN16IE <sup>(1)</sup>	0000
CNPU1	0068	CN15PUE <sup>(1)</sup>	CN14PUE	CN13PUE	CN12PUE	CN11PUE <sup>(1)</sup>	—	CN9PUE	CN8PUE	CN7PUE <sup>(1)</sup>	CN6PUE	CN5PUE	CN4PUE	CN3PUE	CN2PUE	CN1PUE	CN0PUE	0000
CNPU2	006A	—	CN30PUE	CN29PUE	—	CN27PUE <sup>(1)</sup>	—	—	CN24PUE <sup>(1)</sup>	CN23PUE	CN22PUE	CN21PUE	—	—	—	—	CN16PUE <sup>(1)</sup>	0000
CNPD1	0070	CN15PDE <sup>(1)</sup>	CN14PDE	CN13PDE	CN12PDE	CN11PDE <sup>(1)</sup>	—	CN9PDE	CN8PDE	CN7PDE <sup>(1)</sup>	CN6PDE	CN5PDE	CN4PDE	CN3PDE	CN2PDE	CN1PDE	CN0PDE	0000
CNPD2	0072	—	CN30PDE	CN29PDE	—	CN27PDE <sup>(1)</sup>	—	—	CN24PDE <sup>(1)</sup>	CN23PDE	CN22PDE	CN21PDE	—	—	—	—	CN16PDE <sup>(1)</sup>	0000

Legend: — = unimplemented, read as '0'. Reset values are shown in hexadecimal.

Note 1: These bits are not implemented in 20-pin devices.

TABLE 4-5: INTERRUPT CONTROLLER REGISTER MAP

File Name	Addr	Bit 15	Bit 14	Bit 13	Bit 12	Bit 11	Bit 10	Bit 9	Bit 8	Bit 7	Bit 6	Bit 5	Bit 4	Bit 3	Bit 2	Bit 1	Bit 0	All Resets
INTCON1	0080	NSTDIS	—	—	—	—	—	—	—	—	—	—	MATHERR	ADDRERR	STKERR	OSCFAIL	—	0000
INTCON2	0082	ALTIVT	DISI	—	—	—	—	—	—	—	—	—	—	—	INT2EP	INT1EP	INT0EP	0000
IFS0	0084	NVMIF	—	AD1IF	U1TXIF	U1RXIF	SPI1IF	SPF1IF	T3IF	T2IF	—	—	—	T1IF	OC1IF	IC1IF	INT0IF	0000
IFS1	0086	U2TXIF	U2RXIF	INT2IF	—	—	—	—	—	—	—	—	INT1IF	CNIF	CMIF	MI2C1IF	SI2C1IF	0000
IFS3	008A	—	RTCIF	—	—	—	—	—	—	—	—	—	—	—	—	—	—	0000
IFS4	008C	—	—	CTMUIF	—	—	—	—	HLVDIF	—	—	—	—	CRCIF	U2ERIF	U1ERIF	—	0000
IEC0	0094	NVMIE	—	AD1IE	U1TXIE	U1RXIE	SPI1IE	SPF1IE	T3IE	T2IE	—	—	—	T1IE	OC1IE	IC1IE	INT0IE	0000
IEC1	0096	U2TXIE	U2RXIE	INT2IE	—	—	—	—	—	—	—	—	INT1IE	CNIE	CMIE	MI2C1IE	SI2C1IE	0000
IEC3	009A	—	RTCIE	—	—	—	—	—	—	—	—	—	—	—	—	—	—	0000
IEC4	009C	—	—	CTMUIE	—	—	—	—	HLVDIE	—	—	—	—	CRCIE	U2ERIE	U1ERIE	—	0000
IPC0	00A4	—	T1IP2	T1IP1	T1IP0	—	OC1IP2	OC1IP1	OC1IP0	—	IC1IP2	IC1IP1	IC1IP0	—	INT0IP2	INT0IP1	INT0IP0	4444
IPC1	00A6	—	T2IP2	T2IP1	T2IP0	—	—	—	—	—	—	—	—	—	—	—	—	4444
IPC2	00A8	—	U1RXIP2	U1RXIP1	U1RXIP0	—	SPI1IP2	SPI1IP1	SPI1IP0	—	SPF1IP2	SPF1IP1	SPF1IP0	—	T3IP2	T3IP1	T3IP0	4444
IPC3	00AA	—	NVMIP2	NVMIP1	NVMIP0	—	—	—	—	—	AD1IP2	AD1IP1	AD1IP0	—	U1TXIP2	U1TXIP1	U1TXIP0	4044
IPC4	00AC	—	CNIP2	CNIP1	CNIP0	—	CMIP2	CMIP1	CMIP0	—	MI2C1P2	MI2C1P1	MI2C1P0	—	SI2C1P2	SI2C1P1	SI2C1P0	4444
IPC5	00AE	—	—	—	—	—	—	—	—	—	—	—	—	—	INT1IP2	INT1IP1	INT1IP0	0004
IPC7	00B2	—	U2TXIP2	U2TXIP1	U2TXIP0	—	U2RXIP2	U2RXIP1	U2RXIP0	—	INT2IP2	INT2IP1	INT2IP0	—	—	—	—	4440
IPC15	00C2	—	—	—	—	—	RTCIP2	RTCIP1	RTCIP0	—	—	—	—	—	—	—	—	0400
IPC16	00C4	—	CRCIP2	CRCIP1	CRCIP0	—	U2ERIP2	U2ERIP1	U2ERIP0	—	U1ERIP2	U1ERIP1	U1ERIP0	—	—	—	—	4440
IPC18	00C8	—	—	—	—	—	—	—	—	—	—	—	—	—	HLVDIP2	HLVDIP1	HLVDIP0	0004
IPC19	00CA	—	—	—	—	—	—	—	—	—	CTMUIP2	CTMUIP1	CTMUIP0	—	—	—	—	0040
INTTREG	00E0	CPUIRQ	—	VHOLD	—	ILR3	ILR2	ILR1	ILR0	—	VECNUM6	VECNUM5	VECNUM4	VECNUM3	VECNUM2	VECNUM1	VECNUM0	0000

Legend: — = unimplemented, read as '0'. Reset values are shown in hexadecimal.

**TABLE 4-6: TIMER REGISTER MAP**

File Name	Addr	Bit 15	Bit 14	Bit 13	Bit 12	Bit 11	Bit 10	Bit 9	Bit 8	Bit 7	Bit 6	Bit 5	Bit 4	Bit 3	Bit 2	Bit 1	Bit 0	All Resets
TMR1	0100	Timer1 Register																0000
PR1	0102	Timer1 Period Register																FFFF
T1CON	0104	TON	—	TSIDL	—	—	—	—	—	—	TGATE	TCKPS1	TCKPS0	—	TSYNC	TCS	—	0000
TMR2	0106	Timer2 Register																0000
TMR3HLD	0108	Timer3 Holding Register (for 32-bit timer operations only)																0000
TMR3	010A	Timer3 Register																0000
PR2	010C	Timer2 Period Register																FFFF
PR3	010E	Timer3 Period Register																FFFF
T2CON	0110	TON	—	TSIDL	—	—	—	—	—	—	TGATE	TCKPS1	TCKPS0	T32	—	TCS	—	0000
T3CON	0112	TON	—	TSIDL	—	—	—	—	—	—	TGATE	TCKPS1	TCKPS0	—	—	TCS	—	0000

**Legend:** — = unimplemented, read as '0'. Reset values are shown in hexadecimal.

**TABLE 4-7: INPUT CAPTURE REGISTER MAP**

File Name	Addr	Bit 15	Bit 14	Bit 13	Bit 12	Bit 11	Bit 10	Bit 9	Bit 8	Bit 7	Bit 6	Bit 5	Bit 4	Bit 3	Bit 2	Bit 1	Bit 0	All Resets
IC1BUF	0140	Input Capture 1 Register																FFFF
IC1CON	0142	—	—	ICSIDL	—	—	—	—	—	ICTMR	IC1	IC10	ICOV	ICBNE	ICM2	ICM1	ICM0	0000

**Legend:** — = unimplemented, read as '0'. Reset values are shown in hexadecimal.

**TABLE 4-8: OUTPUT COMPARE REGISTER MAP**

File Name	Addr	Bit 15	Bit 14	Bit 13	Bit 12	Bit 11	Bit 10	Bit 9	Bit 8	Bit 7	Bit 6	Bit 5	Bit 4	Bit 3	Bit 2	Bit 1	Bit 0	All Resets
OC1RS	0180	Output Compare 1 Secondary Register																FFFF
OC1R	0182	Output Compare 1 Register																FFFF
OC1CON	0184	—	—	OCSIDL	—	—	—	—	—	—	—	—	OCFLT	OCTSEL	OCM2	OCM1	OCM0	0000

**Legend:** — = unimplemented, read as '0'. Reset values are shown in hexadecimal.

**TABLE 4-9: I<sup>2</sup>C™ REGISTER MAP**

File Name	Addr	Bit 15	Bit 14	Bit 13	Bit 12	Bit 11	Bit 10	Bit 9	Bit 8	Bit 7	Bit 6	Bit 5	Bit 4	Bit 3	Bit 2	Bit 1	Bit 0	All Resets	
I2C1RCV	0200	—	—	—	—	—	—	—	—	I2C1 Receive Register									0000
I2C1TRN	0202	—	—	—	—	—	—	—	—	I2C1 Transmit Register									00FF
I2C1BRG	0204	—	—	—	—	—	—	—	I2C1 Baud Rate Generator Register										0000
I2C1CON	0206	I2CEN	—	I2CSIDL	SCLREL	IPMIEN	A10M	DISSLW	SMEN	GCEN	STREN	ACKDT	ACKEN	RCEN	PEN	RSEN	SEN	1000	
I2C1STAT	0208	ACKSTAT	TRSTAT	—	—	—	BCL	GCSTAT	ADD10	IWCOL	I2COV	D/Ā	P	S	R/W	RBF	TBF	0000	
I2C1ADD	020A	—	—	—	—	—	—	I2C1 Address Register										0000	
I2C1MSK	020C	—	—	—	—	—	—	AMSK9	AMSK8	AMSK7	AMSK6	AMSK5	AMSK4	AMSK3	AMSK2	AMSK1	AMSK0	0000	

**Legend:** — = unimplemented, read as '0'. Reset values are shown in h.5adecimal.

**TABLE 4-10: UART REGISTER MAP**

File Name	Addr	Bit 15	Bit 14	Bit 13	Bit 12	Bit 11	Bit 10	Bit 9	Bit 8	Bit 7	Bit 6	Bit 5	Bit 4	Bit 3	Bit 2	Bit 1	Bit 0	All Resets
U1MODE	0220	UARTEN	—	USIDL	IREN	RTSMD	—	UEN1	UEN0	WAKE	LPBACK	ABAUD	RXINV	BRGH	PDSEL1	PDSEL0	STSEL	0000
U1STA	0222	UTXISEL1	UTXINV	UTXISEL0	—	UTXBRK	UTXEN	UTXBF	TRMT	URXISEL1	URXISEL0	ADDEN	RIDLE	PERR	FERR	OERR	URXDA	0110
U1TXREG	0224	—	—	—	—	—	—	—	UART1 Transmit Register									0000
U1RXREG	0226	—	—	—	—	—	—	—	UART1 Receive Register									0000
U1BRG	0228	Baud Rate Generator Prescaler Register																0000
U2MODE	0230	UARTEN	—	USIDL	IREN	RTSMD	—	UEN1	UEN0	WAKE	LPBACK	ABAUD	RXINV	BRGH	PDSEL1	PDSEL0	STSEL	0000
U2STA	0232	UTXISEL1	UTXINV	UTXISEL0	—	UTXBRK	UTXEN	UTXBF	TRMT	URXISEL1	URXISEL0	ADDEN	RIDLE	PERR	FERR	OERR	URXDA	0110
U2TXREG	0234	—	—	—	—	—	—	—	UART2 Transmit Register									0000
U2RXREG	0236	—	—	—	—	—	—	—	UART2 Receive Register									0000
U2BRG	0238	Baud Rate Generator Prescaler																0000

**Legend:** — = unimplemented, read as '0'. Reset values are shown in hexadecimal.

**TABLE 4-11: SPI REGISTER MAP**

File Name	Addr	Bit 15	Bit 14	Bit 13	Bit 12	Bit 11	Bit 10	Bit 9	Bit 8	Bit 7	Bit 6	Bit 5	Bit 4	Bit 3	Bit 2	Bit 1	Bit 0	All Resets
SPI1STAT	0240	SPIEN	—	SPISIDL	—	—	SPIBEC2	SPIBEC1	SPIBEC0	SRMPT	SPIROV	SRXMPT	ISEL2	ISEL1	ISEL0	SPITBF	SPIRBF	0000
SPI1CON1	0242	—	—	—	DISSCK	DISSDO	MODE16	SMP	CKE	SSEN	CKP	MSTEN	SPRE2	SPRE1	SPRE0	PPRE1	PPRE0	0000
SPI1CON2	0244	FRMEN	SPIFSD	SPIFPOL	—	—	—	—	—	—	—	—	—	—	—	SPIFE	SPIBEN	0000
SPI1BUF	0248	SPI1 Transmit/Receive Buffer																0000

**Legend:** — = unimplemented, read as '0'. Reset values are shown in hexadecimal.

**TABLE 4-12: PORTA REGISTER MAP**

File Name	Addr	Bit 15	Bit 14	Bit 13	Bit 12	Bit 11	Bit 10	Bit 9	Bit 8	Bit 7	Bit 6	Bit 5 <sup>(1)</sup>	Bit 4	Bit 3	Bit 2	Bit 1	Bit 0	All Resets
TRISA	02C0	—	—	—	—	—	—	—	—	TRISA7 <sup>(4)</sup>	TRISA6	—	TRISA4	TRISA3 <sup>(5,6)</sup>	TRISA2 <sup>(5)</sup>	TRISA1	TRISA0	00DF
PORTA	02C2	—	—	—	—	—	—	—	—	RA7 <sup>(4)</sup>	RA6	RA5	RA4 <sup>(3)</sup>	RA3 <sup>(5,6)</sup>	RA2 <sup>(5)</sup>	RA1 <sup>(2)</sup>	RA0 <sup>(2)</sup>	xxxx
LATA	02C4	—	—	—	—	—	—	—	—	LATA7 <sup>(4)</sup>	LATA6	—	LATA4	LATA3 <sup>(5,6)</sup>	LATA2 <sup>(5)</sup>	LATA1	LATA0	xxxx
ODCA	02C6	—	—	—	—	—	—	—	—	ODA7 <sup>(4)</sup>	ODA6	—	ODA4	ODA3 <sup>(5,6)</sup>	ODA2 <sup>(5)</sup>	ODA1	ODA0	0000

**Legend:** — = unimplemented, read as '0'. Reset values are shown in hexadecimal.

**Note 1:** This bit is available only when MCLRE = 0.

**2:** A read of RA1 and RA0 results in '0' when debug is active on the PGC2/PGD2 pin.

**3:** A read of RA4 results in '0' when debug is active on the PGC3/PGD3 pin.

**4:** These bits are not implemented in 20-pin devices.

**5:** These bits are available only when the primary oscillator is disabled (POSCMD<1:0> = 00); otherwise read as '0'.

**6:** These bits are available only when the primary oscillator is disabled or EC mode is selected (POSCMD<1:0> = 00 or 11) and CLK0 is disabled (OSCIOFNC = 0); otherwise read as '0'.

**TABLE 4-13: PORTB REGISTER MAP**

File Name	Addr	Bit 15	Bit 14	Bit 13	Bit 12	Bit 11	Bit 10	Bit 9	Bit 8	Bit 7	Bit 6	Bit 5	Bit 4	Bit 3	Bit 2	Bit 1	Bit 0	All Resets
TRISB	02C8	TRISB15	TRISB14	TRISB13	TRISB12	TRISB11 <sup>(3)</sup>	TRISB10 <sup>(3)</sup>	TRISB9	TRISB8	TRISB7	TRISB6 <sup>(3)</sup>	TRISB5 <sup>(3)</sup>	TRISB4	TRISB3 <sup>(3)</sup>	TRISB2	TRISB1	TRISB0	FFFF
PORTB	02CA	RB15	RB14	RB13	RB12	RB11 <sup>(3)</sup>	RB10 <sup>(3)</sup>	RB9	RB8	RB7	RB6 <sup>(3)</sup>	RB5 <sup>(3)</sup>	RB4 <sup>(2)</sup>	RB3 <sup>(3)</sup>	RB2	RB1 <sup>(1)</sup>	RB0 <sup>(1)</sup>	xxxx
LATB	02CC	LATB15	LATB14	LATB13	LATB12	LATB11 <sup>(3)</sup>	LATB10 <sup>(3)</sup>	LATB9	LATB8	LATB7	LATB6 <sup>(3)</sup>	LATB5 <sup>(3)</sup>	LATB4	LATB3 <sup>(3)</sup>	LATB2	LATB1	LATB0	xxxx
ODCB	02CE	ODB15	ODB14	ODB13	ODB12	ODB11	ODB10	ODB9	ODB8	ODB7	ODB6	ODB5	ODB4	ODB3	ODB2	ODB1	ODB0	0000

**Legend:** — = unimplemented, read as '0'. Reset values are shown in hexadecimal.

**Note 1:** A read of RB1 and RB0 results in '0' when debug is active on the PGEC1/PGED1 pins.

**2:** A read of RB4 results in '0' when debug is active on the PGEC3/PGED3 pins.

**3:** PORTB bits, 11, 10, 6, 5 and 3, are not implemented in 20-pin devices.

**TABLE 4-14: PAD CONFIGURATION REGISTER MAP**

File Name	Addr	Bit 15	Bit 14	Bit 13	Bit 12	Bit 11	Bit 10	Bit 9	Bit 8	Bit 7	Bit 6	Bit 5	Bit 4	Bit 3	Bit 2	Bit 1	Bit 0	All Resets
PADCFG1	02FC	—	—	—	—	—	—	—	—	—	—	—	SMBUSDEL	OC1TRIS	RTSECSEL1	RTSECSEL0	—	0000

**Legend:** — = unimplemented, read as '0'. Reset values are shown in hexadecimal.

TABLE 4-15: A/D REGISTER MAP

File Name	Addr	Bit 15	Bit 14	Bit 13	Bit 12	Bit 11	Bit 10	Bit 9	Bit 8	Bit 7	Bit 6	Bit 5	Bit 4	Bit 3	Bit 2	Bit 1	Bit 0	All Resets
ADC1BUF0	0300	A/D Data Buffer 0																xxxx
ADC1BUF1	0302	A/D Data Buffer 1																xxxx
ADC1BUF2	0304	A/D Data Buffer 2																xxxx
ADC1BUF3	0306	A/D Data Buffer 3																xxxx
ADC1BUF4	0308	A/D Data Buffer 4																xxxx
ADC1BUF5	030A	A/D Data Buffer 5																xxxx
ADC1BUF6	030C	A/D Data Buffer 6																xxxx
ADC1BUF7	030E	A/D Data Buffer 7																xxxx
ADC1BUF8	0310	A/D Data Buffer 8																xxxx
ADC1BUF9	0312	A/D Data Buffer 9																xxxx
ADC1BUFA	0314	A/D Data Buffer 10																xxxx
ADC1BUFB	0316	A/D Data Buffer 11																xxxx
ADC1BUFC	0318	A/D Data Buffer 12																xxxx
ADC1BUFD	031A	A/D Data Buffer 13																xxxx
ADC1BUFE	031C	A/D Data Buffer 14																xxxx
ADC1BUFF	031E	A/D Data Buffer 15																xxxx
AD1CON1	0320	ADON	—	ADSIDL	—	—	—	FORM1	FORM0	SSRC2	SSRC1	SSRC0	—	—	ASAM	SAMP	DONE	0000
AD1CON2	0322	VCFG2	VCFG1	VCFG0	OFFCAL	—	CSCNA	—	—	BUFS	—	SMP13	SMP12	SMP11	SMP10	BUFM	ALTS	0000
AD1CON3	0324	ADRC	—	—	SAMC4	SAMC3	SAMC2	SAMC1	SAMC0	—	—	ADCS5	ADCS4	ADCS3	ADCS2	ADCS1	ADCS0	0000
AD1CHS	0328	CH0NB	—	—	—	CH0SB3	CH0SB2	CH0SB1	CH0SB0	CH0NA	—	—	CH0SA4	CH0SA3	CH0SA2	CH0SA1	CH0SA0	0000
AD1PCFG	032C	—	—	—	PCFG12	PCFG11	PCFG10	—	—	—	—	PCFG5	PCFG4	PCFG3	PCFG2	PCFG1	PCFG0	0000
AD1CSSL	0330	—	—	—	CSSL12	CSSL11	CSSL10	—	—	—	—	CSSL5	CSSL4	CSSL3	CSSL2	CSSL1	CSSL0	0000

Legend: — = unimplemented, read as '0'. Reset values are shown in hexadecimal.

TABLE 4-16: CTMU REGISTER MAP

File Name	Addr	Bit 15	Bit 14	Bit 13	Bit 12	Bit 11	Bit 10	Bit 9	Bit 8	Bit 7	Bit 6	Bit 5	Bit 4	Bit 3	Bit 2	Bit 1	Bit 0	All Resets
CTMUCON	033C	CTMUEN	—	CTMUSIDL	TGEN	EDGEN	EDGSEQEN	IDISSEN	CTTRIG	EDG2POL	EDG2SEL1	EDG2SEL0	EDG1POL	EDG1SEL1	EDG1SEL0	EDG2STAT	EDG1STAT	0000
CTMUICON	033E	ITRIM5	ITRIM4	ITRIM3	ITRIM2	ITRIM1	ITRIM0	IRNG1	IRNG0	—	—	—	—	—	—	—	—	0000

Legend: — = unimplemented, read as '0'. Reset values are shown in hexadecimal.

**TABLE 4-17: REAL-TIME CLOCK AND CALENDAR REGISTER MAP**

File Name	Addr	Bit 15	Bit 14	Bit 13	Bit 12	Bit 11	Bit 10	Bit 9	Bit 8	Bit 7	Bit 6	Bit 5	Bit 4	Bit 3	Bit 2	Bit 1	Bit 0	All Resets
ALRMVAL	0620	Alarm Value Register Window Based on ALRMPTR<15:0>																xxxx
ALCFGRPT	0622	ALRMEN	CHIME	AMASK3	AMASK2	AMASK1	AMASK0	ALRMPTR1	ALRMPTR0	ARPT7	ARPT6	ARPT5	ARPT4	ARPT3	ARPT2	ARPT1	ARPT0	0000
RTCVAL	0624	RTCC Value Register Window Based on RTCPTR<15:0>																xxxx
RCFGCAL	0626	RTCEN	—	RTCWREN	RTCSYNC	HALFSEC	RTCOE	RTCPTR1	RTCPTR0	CAL7	CAL6	CAL5	CAL4	CAL3	CAL2	CAL1	CAL0	0000

**Legend:** — = unimplemented, read as '0'. Reset values are shown in hexadecimal.

**TABLE 4-18: DUAL COMPARATOR REGISTER MAP**

File Name	Addr	Bit 15	Bit 14	Bit 13	Bit 12	Bit 11	Bit 10	Bit 9	Bit 8	Bit 7	Bit 6	Bit 5	Bit 4	Bit 3	Bit 2	Bit 1	Bit 0	All Resets
CMSTAT	0630	CMSIDL	—	—	—	—	—	C2EVT	C1EVT	—	—	—	—	—	—	C2OUT	C1OUT	0000
CVRCON	0632	—	—	—	—	—	—	—	—	CVREN	CVROE	CVRR	CVRSS	CVR3	CVR2	CVR1	CVR0	0000
CM1CON	0634	CON	COE	CPOL	CLPWR	—	—	CEVT	COUT	EVPOL1	EVPOL0	—	CREF	—	—	CCH1	CCH0	0000
CM2CON	0636	CON	COE	CPOL	CLPWR	—	—	CEVT	COUT	EVPOL1	EVPOL0	—	CREF	—	—	CCH1	CCH0	0000

**Legend:** — = unimplemented, read as '0'. Reset values are shown in hexadecimal.

**TABLE 4-19: CRC REGISTER MAP**

File Name	Addr	Bit 15	Bit 14	Bit 13	Bit 12	Bit 11	Bit 10	Bit 9	Bit 8	Bit 7	Bit 6	Bit 5	Bit 4	Bit 3	Bit 2	Bit 1	Bit 0	All Resets	
CRCCON	0640	—	—	CSIDL	VWORD4	VWORD3	VWORD2	VWORD1	VWORD0	CRCFUL	CRCMPT	—	CRCGO	PLEN3	PLEN2	PLEN1	PLEN0	0040	
CRCXOR	0642	X<15:1>																—	0000
CRCDAT	0644	CRC Data Input Register																0000	
CRCWDAT	0646	CRC Result Register																0000	

**Legend:** — = unimplemented, read as '0'. Reset values are shown in hexadecimal.

**TABLE 4-20: CLOCK CONTROL REGISTER MAP**

File Name	Addr	Bit 15	Bit 14	Bit 13	Bit 12	Bit 11	Bit 10	Bit 9	Bit 8	Bit 7	Bit 6	Bit 5	Bit 4	Bit 3	Bit 2	Bit 1	Bit 0	All Resets		
RCON	0740	TRAPR	IOPUWR	SBOREN	—	—	DPSLP	—	PMSLP	EXTR	SWR	SWDTEN	WDTO	SLEEP	IDLE	BOR	POR	(Note 1)		
OSCCON	0742	—	COSC2	COSC1	COSC0	—	NOSC2	NOSC1	NOSC0	CLKLOCK	—	LOCK	—	CF	—	SOSCCEN	OSWEN	(Note 2)		
CLKDIV	0744	ROI	DOZE2	DOZE1	DOZE0	DOZEN	RCDIV2	RCDIV1	RCDIV0	—	—	—	—	—	—	—	—	3140		
OSCTUN	0748	—	—	—	—	—	—	—	—	—	—	TUN5	TUN4	TUN3	TUN2	TUN1	TUN0	0000		
REFOCON	074E	ROEN	—	ROSSLP	ROSEL	RODIV3	RODIV2	RODIV1	RODIV0	—	—	—	—	—	—	—	—	0000		
HLVDCON	0756	HLVDEN	—	HLSIDL	—	—	—	—	—	—	—	VDIR	BGVST	IRVST	—	HLVDL3	HLVDL2	HLVDL1	HLVDL0	0000

**Legend:** — = unimplemented, read as '0'. Reset values are shown in hexadecimal.

**Note 1:** RCON register Reset values are dependent on the type of Reset.

**2:** OSCCON register Reset values are dependent on configuration fuses and by type of Reset.

**TABLE 4-21: DEEP SLEEP REGISTER MAP**

File Name	Addr	Bit 15	Bit 14	Bit 13	Bit 12	Bit 11	Bit 10	Bit 9	Bit 8	Bit 7	Bit 6	Bit 5	Bit 4	Bit 3	Bit 2	Bit 1	Bit 0	All Resets <sup>(1)</sup>
DSCON	0758	DSEN	—	—	—	—	—	—	—	—	—	—	—	—	—	DSBOR	RELEASE	0000
DSWAKE	075A	—	—	—	—	—	—	—	DSINT0	DSFLT	—	—	DSWDT	DSRTCC	DSMCLR	—	DSPOR	0000
DSGPR0	075C	Deep Sleep General Purpose Register 0																0000
DSGPR1	075E	Deep Sleep General Purpose Register 1																0000

**Legend:** — = unimplemented, read as '0'. Reset values are shown in hexadecimal.

**Note 1:** The Deep Sleep registers are only reset on a VDD POR event.

**TABLE 4-22: NVM REGISTER MAP**

File Name	Addr	Bit 15	Bit 14	Bit 13	Bit 12	Bit 11	Bit 10	Bit 9	Bit 8	Bit 7	Bit 6	Bit 5	Bit 4	Bit 3	Bit 2	Bit 1	Bit 0	All Resets
NVMCON	0760	WR	WREN	WRERR	PGMONLY	—	—	—	—	—	ERASE	NVMOP5	NVMOP4	NVMOP3	NVMOP2	NVMOP1	NVMOP0	0000 <sup>(1)</sup>
NVMKEY	0766	—	—	—	—	—	—	—	—	NVMKEY7	NVMKEY6	NVMKEY5	NVMKEY4	NVMKEY3	NVMKEY2	NVMKEY1	NVMKEY0	0000

**Legend:** — = unimplemented, read as '0'. Reset values are shown in hexadecimal.

**Note 1:** Reset value shown is for POR only. Value on other Reset states is dependent on the state of memory write or erase operations at the time of Reset.

**TABLE 4-23: PMD REGISTER MAP**

File Name	Addr	Bit 15	Bit 14	Bit 13	Bit 12	Bit 11	Bit 10	Bit 9	Bit 8	Bit 7	Bit 6	Bit 5	Bit 4	Bit 3	Bit 2	Bit 1	Bit 0	All Resets
PMD1	0770	—	—	T3MD	T2MD	T1MD	—	—	—	I2C1MD	U2MD	U1MD	—	SPI1MD	—	—	ADC1MD	0000
PMD2	0772	—	—	—	—	—	—	—	IC1MD	—	—	—	—	—	—	—	OC1MD	0000
PMD3	0774	—	—	—	—	—	CMPMD	RTCCMD	—	CRCMD	—	—	—	—	—	—	—	0000
PMD4	0776	—	—	—	—	—	—	—	—	—	—	—	EEMD	REFOMD	CTMUMD	HLVDM	—	0000

**Legend:** — = unimplemented, read as '0'. Reset values are shown in hexadecimal.



## 4.2.5 SOFTWARE STACK

In addition to its use as a working register, the W15 register in PIC24F devices is also used as a Software Stack Pointer. The pointer always points to the first available free word and grows from lower to higher addresses. It pre-decrements for stack pops and post-increments for stack pushes, as depicted in Figure 4-4.

For a PC push during any CALL instruction, the MSB of the PC is Zero-Extended before the push, ensuring that the MSB is always clear.

**Note:** A PC push during exception processing will concatenate the SRL register to the MSB of the PC prior to the push.

The Stack Pointer Limit Value (SPLIM) register, associated with the Stack Pointer, sets an upper address boundary for the stack. SPLIM is uninitialized at Reset. As is the case for the Stack Pointer,  $SPLIM<0>$  is forced to '0' as all stack operations must be word-aligned. Whenever an EA is generated using W15 as a source or destination pointer, the resulting address is compared with the value in SPLIM. If the contents of the Stack Pointer (W15) and the SPLIM register are equal, and a push operation is performed, a stack error trap will not occur. The stack error trap will occur on a subsequent push operation.

Thus, for example, if it is desirable to cause a stack error trap when the stack grows beyond address, 0DF6 in RAM, initialize the SPLIM with the value, 0DF4.

Similarly, a Stack Pointer underflow (stack error) trap is generated when the Stack Pointer address is found to be less than 0800h. This prevents the stack from interfering with the Special Function Register (SFR) space.

**Note:** A write to the SPLIM register should not be immediately followed by an indirect read operation using W15.

**FIGURE 4-4: CALL STACK FRAME**



## 4.3 Interfacing Program and Data Memory Spaces

The PIC24F architecture uses a 24-bit wide program space and 16-bit wide data space. The architecture is also a modified Harvard scheme, meaning that data can also be present in the program space. To use this data successfully, it must be accessed in a way that preserves the alignment of information in both spaces.

Apart from the normal execution, the PIC24F architecture provides two methods by which the program space can be accessed during operation:

- Using table instructions to access individual bytes or words anywhere in the program space
- Remapping a portion of the program space into the data space, PSV

Table instructions allow an application to read or write small areas of the program memory. This makes the method ideal for accessing data tables that need to be updated from time to time. It also allows access to all bytes of the program word. The remapping method allows an application to access a large block of data on a read-only basis, which is ideal for look ups from a large table of static data. It can only access the least significant word (lsw) of the program word.

### 4.3.1 ADDRESSING PROGRAM SPACE

Since the address ranges for the data and program spaces are 16 and 24 bits, respectively, a method is needed to create a 23-bit or 24-bit program address from 16-bit data registers. The solution depends on the interface method to be used.

For table operations, the 8-bit Table Memory Page Address register (TBLPAG) is used to define a 32K word region within the program space. This is concatenated with a 16-bit EA to arrive at a full 24-bit program space address. In this format, the Most Significant bit (MSb) of TBLPAG is used to determine if the operation occurs in the user memory (TBLPAG<7> = 0) or the configuration memory (TBLPAG<7> = 1).

For remapping operations, the 8-bit Program Space Visibility Page Address register (PSVPAG) is used to define a 16K word page in the program space. When the MSb of the EA is '1', PSVPAG is concatenated with the lower 15 bits of the EA to form a 23-bit program space address. Unlike the table operations, this limits remapping operations strictly to the user memory area.

See Table 4-24 and Figure 4-5 to know how the program EA is created for table operations and remapping accesses from the data EA. Here, P<23:0> refers to a program space word, whereas D<15:0> refers to a data space word.

# PIC24F16KA102 FAMILY

**TABLE 4-24: PROGRAM SPACE ADDRESS CONSTRUCTION**

Access Type	Access Space	Program Space Address				
		<23>	<22:16>	<15>	<14:1>	<0>
Instruction Access (Code Execution)	User	0	PC<22:1>			0
		0xxx xxxx xxxx xxxx xxxx xxx0				
TBLRD/TBLWT (Byte/Word Read/Write)	User	TBLPAG<7:0>		Data EA<15:0>		
		0xxx xxxx		xxxx xxxx xxxx xxxx		
	Configuration	TBLPAG<7:0>		Data EA<15:0>		
		1xxx xxxx		xxxx xxxx xxxx xxxx		
Program Space Visibility (Block Remap/Read)	User	0	PSVPAG<7:0> <sup>(2)</sup>		Data EA<14:0> <sup>(1)</sup>	
		0	xxxx xxxx		xxx xxxx xxxx xxxx	

- Note 1:** Data EA<15> is always '1' in this case, but is not used in calculating the program space address. Bit 15 of the address is PSVPAG<0>.
- Note 2:** PSVPAG can have only two values ('00' to access program memory and FF to access data EEPROM) on the PIC24F16KA102 family.

**FIGURE 4-5: DATA ACCESS FROM PROGRAM SPACE ADDRESS GENERATION**



- Note 1:** The LSb of program space addresses is always fixed as '0' in order to maintain word alignment of data in the program and data spaces.
- Note 2:** Table operations are not required to be word-aligned. Table read operations are permitted in the configuration memory space.

## 4.3.2 DATA ACCESS FROM PROGRAM MEMORY AND DATA EEPROM MEMORY USING TABLE INSTRUCTIONS

The TBLRDL and TBLWTL instructions offer a direct method of reading or writing the lower word of any address within the program memory without going through data space. It also offers a direct method of reading or writing a word of any address within data EEPROM memory. The TBLRDH and TBLWTH instructions are the only method to read or write the upper 8 bits of a program space word as data.

**Note:** The TBLRDH and TBLWTH instructions are not used while accessing data EEPROM memory.

The PC is incremented by 2 for each successive 24-bit program word. This allows program memory addresses to directly map to data space addresses. Program memory can thus be regarded as two 16-bit, word-wide address spaces, residing side by side, each with the same address range. TBLRDL and TBLWTL access the space which contains the least significant data word, and TBLRDH and TBLWTH access the space which contains the upper data byte.

Two table instructions are provided to move byte or word-sized (16-bit) data to and from program space. Both function as either byte or word operations.

1. TBLRDL (Table Read Low): In Word mode, it maps the lower word of the program space location ( $P<15:0>$ ) to a data address ( $D<15:0>$ ).

In Byte mode, either the upper or lower byte of the lower program word is mapped to the lower byte of a data address. The upper byte is selected when byte select is '1'; the lower byte is selected when it is '0'.

2. TBLRDH (Table Read High): In Word mode, it maps the entire upper word of a program address ( $P<23:16>$ ) to a data address. Note that  $D<15:8>$ , the 'phantom' byte, will always be '0'.

In Byte mode, it maps the upper or lower byte of the program word to  $D<7:0>$  of the data address, as above. Note that the data will always be '0' when the upper 'phantom' byte is selected (byte select = 1).

In a similar fashion, two table instructions, TBLWTH and TBLWTL, are used to write individual bytes or words to a program space address. The details of their operation are explained in [Section 5.0 "Flash Program Memory"](#).

For all table operations, the area of program memory space to be accessed is determined by the Table Memory Page Address register (TBLPAG). TBLPAG covers the entire program memory space of the device, including user and configuration spaces. When  $TBLPAG<7> = 0$ , the table page is located in the user memory space. When  $TBLPAG<7> = 1$ , the page is located in configuration space.

**Note:** Only table read operations will execute in the configuration memory space, and only then, in implemented areas, such as the Device ID. Table write operations are not allowed.

**FIGURE 4-6: ACCESSING PROGRAM MEMORY WITH TABLE INSTRUCTIONS**

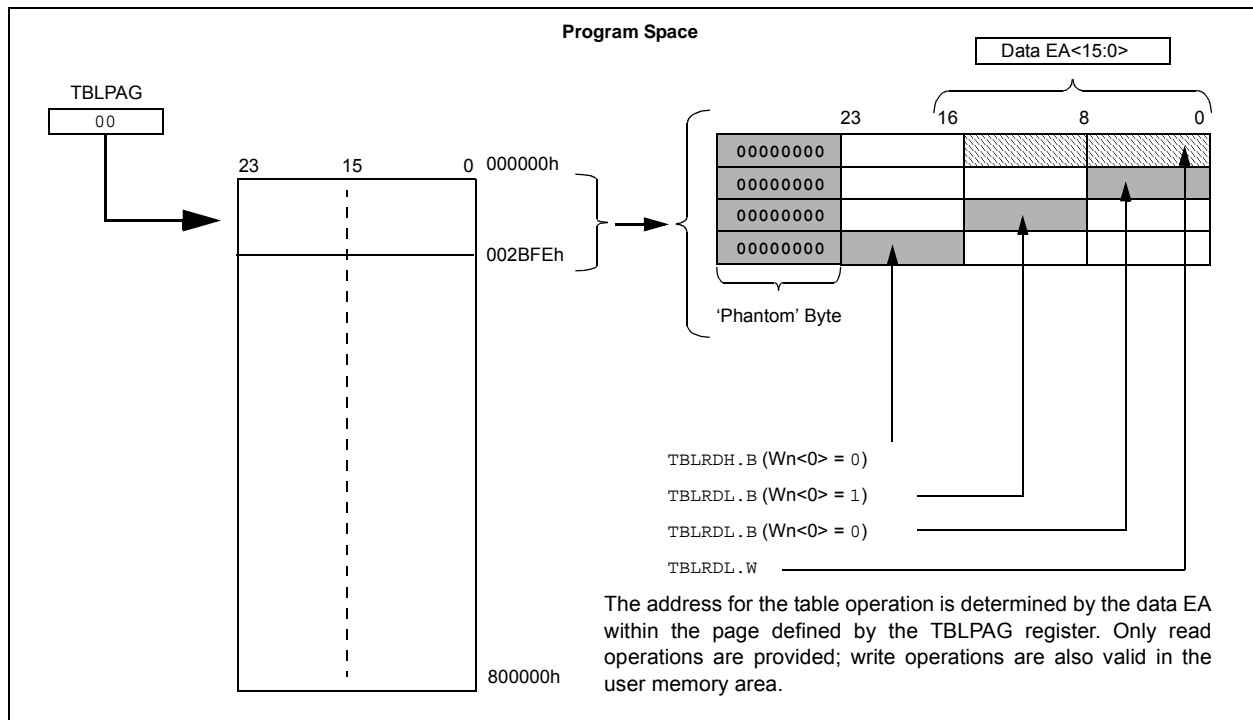

# PIC24F16KA102 FAMILY

## 4.3.3 READING DATA FROM PROGRAM MEMORY USING PROGRAM SPACE VISIBILITY

The upper 32 Kbytes of data space may optionally be mapped into an 8K word page (in PIC24F08KA1XX devices) and a 16K word page (in PIC24F16KA1XX devices) of the program space. This provides transparent access of stored constant data from the data space without the need to use special instructions (i.e., TBLRD<sub>L</sub>/H).

Program space access through the data space occurs if the MSb of the data space, EA, is '1', and PSV is enabled by setting the PSV bit in the CPU Control (CORCON<2>) register. The location of the program memory space to be mapped into the data space is determined by the Program Space Visibility Page Address register (PSVPAG). This 8-bit register defines any one of 256 possible pages of 16K words in program space. In effect, PSVPAG functions as the upper 8 bits of the program memory address, with the 15 bits of the EA functioning as the lower bits.

By incrementing the PC by 2 for each program memory word, the lower 15 bits of data space addresses directly map to the lower 15 bits in the corresponding program space addresses.

Data reads from this area add an additional cycle to the instruction being executed, since two program memory fetches are required.

Although each data space address, 8000h and higher, maps directly into a corresponding program memory address (see Figure 4-7), only the lower 16 bits of the 24-bit program word are used to contain the data. The upper 8 bits of any program space locations used as data should be programmed with '1111 1111' or '0000 0000' to force a NOP. This prevents possible issues should the area of code ever be accidentally executed.

**Note:** PSV access is temporarily disabled during table reads/writes.

For operations that use PSV and are executed outside a REPEAT loop, the MOV and MOV.D instructions will require one instruction cycle in addition to the specified execution time. All other instructions will require two instruction cycles in addition to the specified execution time.

For operations that use PSV, which are executed inside a REPEAT loop, there will be some instances that require two instruction cycles in addition to the specified execution time of the instruction:

- Execution in the first iteration
- Execution in the last iteration
- Execution prior to exiting the loop due to an interrupt
- Execution upon re-entering the loop after an interrupt is serviced

Any other iteration of the REPEAT loop will allow the instruction accessing data, using PSV, to execute in a single cycle.

**FIGURE 4-7: PROGRAM SPACE VISIBILITY OPERATION**



# PIC24F16KA102 FAMILY

## 5.0 FLASH PROGRAM MEMORY

**Note:** This data sheet summarizes the features of this group of PIC24F devices. It is not intended to be a comprehensive reference source. For more information on Flash Programming, refer to the “PIC24F Family Reference Manual”, Section 4. “Program Memory” (DS39715).

The PIC24FJ64GA family of devices contains internal Flash program memory for storing and executing application code. The memory is readable, writable and erasable when operating with VDD over 1.8V.

Flash memory can be programmed in three ways:

- In-Circuit Serial Programming™ (ICSP™)
- Run-Time Self-Programming (RTSP)
- Enhanced In-Circuit Serial Programming (Enhanced ICSP)

ICSP allows a PIC24F16KA102 device to be serially programmed while in the end application circuit. This is simply done with two lines for the programming clock and programming data (which are named PGCx and PGDx, respectively), and three other lines for power (VDD), ground (VSS) and Master Clear/Program Mode Entry Voltage (MCLR/VPP). This allows customers to manufacture boards with unprogrammed devices and then program the microcontroller just before shipping the product. This also allows the most recent firmware or custom firmware to be programmed.

Real-Time Self-Programming (RTSP) is accomplished using TBLRD (table read) and TBLWT (table write) instructions. With RTSP, the user may write program memory data in blocks of 32 instructions (96 bytes) at a time, and erase program memory in blocks of 32, 64 and 128 instructions (96, 192 and 384 bytes) at a time.

The NVMOP<1:0> (NVMCON<1:0>) bits decide the erase block size.

### 5.1 Table Instructions and Flash Programming

Regardless of the method used, Flash memory programming is done with the table read and write instructions. These allow direct read and write access to the program memory space from the data memory while the device is in normal operating mode. The 24-bit target address in the program memory is formed using the TBLPAG<7:0> bits and the Effective Address (EA) from a W register, specified in the table instruction, as depicted in Figure 5-1.

The TBLRDL and the TBLWTL instructions are used to read or write to bits<15:0> of program memory. TBLRDL and TBLWTL can access program memory in both Word and Byte modes.

The TBLRDH and TBLWTH instructions are used to read or write to bits<23:16> of program memory. TBLRDH and TBLWTH can also access program memory in Word or Byte mode.

**FIGURE 5-1: ADDRESSING FOR TABLE REGISTERS**



# PIC24F16KA102 FAMILY

---

## 5.2 RTSP Operation

The PIC24F Flash program memory array is organized into rows of 32 instructions or 96 bytes. RTSP allows the user to erase blocks of 1 row, 2 rows and 4 rows (32, 64 and 128 instructions) at a time and to program one row at a time. It is also possible to program single words.

The 1-row (96 bytes), 2-row (192 bytes) and 4-row (384 bytes) erase blocks, and single row write block (96 bytes) are edge-aligned, from the beginning of program memory.

When data is written to program memory using `TBLWT` instructions, the data is not written directly to memory. Instead, data written using table writes is stored in holding latches until the programming sequence is executed.

Any number of `TBLWT` instructions can be executed and a write will be successfully performed. However, 32 `TBLWT` instructions are required to write the full row of memory.

The basic sequence for RTSP programming is to set up a Table Pointer, then do a series of `TBLWT` instructions to load the buffers. Programming is performed by setting the control bits in the `NVMCON` register.

Data can be loaded in any order and the holding registers can be written to multiple times before performing a write operation. Subsequent writes, however, will wipe out any previous writes.

**Note:** Writing to a location multiple times without erasing it is not recommended.

All of the table write operations are single-word writes (two instruction cycles), because only the buffers are written. A programming cycle is required for programming each row.

## 5.3 Enhanced In-Circuit Serial Programming

Enhanced ICSP uses an on-board bootloader, known as the program executive, to manage the programming process. Using an SPI data frame format, the program executive can erase, program and verify program memory. For more information on Enhanced ICSP, see the device programming specification.

## 5.4 Control Registers

There are two SFRs used to read and write the program Flash memory: `NVMCON` and `NVMKEY`.

The `NVMCON` register ([Register 5-1](#)) controls the blocks that need to be erased, which memory type is to be programmed and when the programming cycle starts.

`NVMKEY` is a write-only register that is used for write protection. To start a programming or erase sequence, the user must consecutively write 55h and AAh to the `NVMKEY` register. Refer to [Section 5.5 “Programming Operations”](#) for further details.

## 5.5 Programming Operations

A complete programming sequence is necessary for programming or erasing the internal Flash in RTSP mode. During a programming or erase operation, the processor stalls (waits) until the operation is finished. Setting the `WR` bit (`NVMCON<15>`) starts the operation and the `WR` bit is automatically cleared when the operation is finished.

# PIC24F16KA102 FAMILY

## REGISTER 5-1: NVMCON: FLASH MEMORY CONTROL REGISTER

R/SO-0, HC	R/W-0	R/W-0	R/W-0	U-0	U-0	U-0	U-0
WR	WREN	WRERR	PGMONLY <sup>(4)</sup>	—	—	—	—
bit 15							bit 8

U-0	R/W-0	R/W-0	R/W-0	R/W-0	R/W-0	R/W-0	R/W-0
—	ERASE	NVMOP5 <sup>(1)</sup>	NVMOP4 <sup>(1)</sup>	NVMOP3 <sup>(1)</sup>	NVMOP2 <sup>(1)</sup>	NVMOP1 <sup>(1)</sup>	NVMOP0 <sup>(1)</sup>
bit 7							bit 0

<b>Legend:</b>	SO = Settable Only bit	HC = Hardware Clearable bit
-n = Value at POR	'1' = Bit is set	R = Readable bit
'0' = Bit is cleared	x = Bit is unknown	W = Writable bit
		U = Unimplemented bit, read as '0'

- bit 15     **WR:** Write Control bit  
1 = Initiates a Flash memory program or erase operation. The operation is self-timed and the bit is cleared by hardware once the operation is complete  
0 = Program or erase operation is complete and inactive
- bit 14     **WREN:** Write Enable bit  
1 = Enable Flash program/erase operations  
0 = Inhibit Flash program/erase operations
- bit 13     **WRERR:** Write Sequence Error Flag bit  
1 = An improper program or erase sequence attempt or termination has occurred (bit is set automatically on any set attempt of the WR bit)  
0 = The program or erase operation completed normally
- bit 12     **PGMONLY:** Program Only Enable bit<sup>(4)</sup>
- bit 11-7   **Unimplemented:** Read as '0'
- bit 6       **ERASE:** Erase/Program Enable bit  
1 = Perform the erase operation specified by NVMOP<5:0> on the next WR command  
0 = Perform the program operation specified by NVMOP<5:0> on the next WR command
- bit 5-0     **NVMOP<5:0>:** Programming Operation Command Byte bits<sup>(1)</sup>  
Erase Operations (when ERASE bit is '1'):  
1010xx = Erase entire boot block (including code-protected boot block)<sup>(2)</sup>  
1001xx = Erase entire memory (including boot block, configuration block, general block)<sup>(2)</sup>  
011010 = Erase 4 rows of Flash memory<sup>(3)</sup>  
011001 = Erase 2 rows of Flash memory<sup>(3)</sup>  
011000 = Erase 1 row of Flash memory<sup>(3)</sup>  
0101xx = Erase entire configuration block (except code protection bits)  
0100xx = Erase entire data EEPROM<sup>(4)</sup>  
0011xx = Erase entire general memory block programming operations  
0001xx = Write 1 row of Flash memory (when ERASE bit is '0')<sup>(3)</sup>

- Note 1:** All other combinations of NVMOP<5:0> are no operation.  
**Note 2:** Available in ICSP™ mode only. Refer to device programming specification.  
**Note 3:** The address in the Table Pointer decides which rows will be erased.  
**Note 4:** This bit is used only while accessing data EEPROM.

# PIC24F16KA102 FAMILY

## 5.5.1 PROGRAMMING ALGORITHM FOR FLASH PROGRAM MEMORY

The user can program one row of Flash program memory at a time by erasing the programmable row. The general process is:

1. Read a row of program memory (32 instructions) and store in data RAM.
2. Update the program data in RAM with the desired new data.
3. Erase a row (see [Example 5-1](#)):
  - a) Set the NVMOP bits (NVMCON<5:0>) to '011000' to configure for row erase. Set the ERASE (NVMCON<6>) and WREN (NVMCON<14>) bits.
  - b) Write the starting address of the block to be erased into the TBLPAG and W registers.
  - c) Write 55h to NVMKEY.
  - d) Write AAh to NVMKEY.
  - e) Set the WR bit (NVMCON<15>). The erase cycle begins and the CPU stalls for the duration of the erase cycle. When the erase is done, the WR bit is cleared automatically.
4. Write the first 32 instructions from data RAM into the program memory buffers (see [Example 5-1](#)).
5. Write the program block to Flash memory:
  - a) Set the NVMOP bits to '000100' to configure for row programming. Clear the ERASE bit and set the WREN bit.
  - b) Write 55h to NVMKEY.
  - c) Write AAh to NVMKEY.
  - d) Set the WR bit. The programming cycle begins and the CPU stalls for the duration of the write cycle. When the write to Flash memory is done, the WR bit is cleared automatically.

For protection against accidental operations, the write initiate sequence for NVMKEY must be used to allow any erase or program operation to proceed. After the programming command has been executed, the user must wait for the programming time until programming is complete. The two instructions following the start of the programming sequence should be NOPs, as displayed in [Example 5-5](#).

### EXAMPLE 5-1: ERASING A PROGRAM MEMORY ROW – ASSEMBLY LANGUAGE CODE

```
; Set up NVMCON for row erase operation
    MOV    #0x4058, W0          ;
    MOV    W0, NVMCON          ; Initialize NVMCON
; Init pointer to row to be ERASED
    MOV    #tblpage(PROG_ADDR), W0 ;
    MOV    W0, TBLPAG          ; Initialize PM Page Boundary SFR
    MOV    #tbloffset(PROG_ADDR), W0 ; Initialize in-page EA[15:0] pointer
    TBLWTL W0, [W0]           ; Set base address of erase block
    DISI   #5                  ; Block all interrupts
                                ; for next 5 instructions

    MOV    #0x55, W0
    MOV    W0, NVMKEY          ; Write the 55 key
    MOV    #0xAA, W1
    MOV    W1, NVMKEY          ; Write the AA key
    BSET   NVMCON, #WR        ; Start the erase sequence
    NOP                                ; Insert two NOPs after the erase
    NOP                                ; command is asserted
```

### EXAMPLE 5-2: ERASING A PROGRAM MEMORY ROW – 'C' LANGUAGE CODE

```
// C example using MPLAB C30

int __attribute__((space(auto_psv))) progAddr = 0x1234; // Variable located in Pgm Memory, declared as a
// global variable
unsigned int offset;

//Set up pointer to the first memory location to be written

TBLPAG = __builtin_tblpage(&progAddr); // Initialize PM Page Boundary SFR
offset = __builtin_tbloffset(&progAddr); // Initialize lower word of address

__builtin_tblwtl(offset, 0x0000); // Set base address of erase block
// with dummy latch write

NVMCON = 0x4058; // Initialize NVMCON

asm("DISI #5"); // Block all interrupts for next 5 instructions
__builtin_write_NVM(); // C30 function to perform unlock
// sequence and set WR
```



# PIC24F16KA102 FAMILY

## EXAMPLE 5-3: LOADING THE WRITE BUFFERS – ASSEMBLY LANGUAGE CODE

```
; Set up NVMCON for row programming operations
MOV    #0x4004, W0          ;
MOV    W0, NVMCON          ; Initialize NVMCON
; Set up a pointer to the first program memory location to be written
; program memory selected, and writes enabled
MOV    #0x0000, W0          ;
MOV    W0, TBLPAG          ; Initialize PM Page Boundary SFR
MOV    #0x1500, W0          ; An example program memory address
; Perform the TBLWT instructions to write the latches
; 0th_program_word
MOV    #LOW_WORD_0, W2      ;
MOV    #HIGH_BYTE_0, W3     ;
TBLWTL W2, [W0]             ; Write PM low word into program latch
TBLWTH W3, [W0++]           ; Write PM high byte into program latch
; 1st_program_word
MOV    #LOW_WORD_1, W2      ;
MOV    #HIGH_BYTE_1, W3     ;
TBLWTL W2, [W0]             ; Write PM low word into program latch
TBLWTH W3, [W0++]           ; Write PM high byte into program latch
; 2nd_program_word
MOV    #LOW_WORD_2, W2      ;
MOV    #HIGH_BYTE_2, W3     ;
TBLWTL W2, [W0]             ; Write PM low word into program latch
TBLWTH W3, [W0++]           ; Write PM high byte into program latch
.
.
.
; 32nd_program_word
MOV    #LOW_WORD_31, W2     ;
MOV    #HIGH_BYTE_31, W3    ;
TBLWTL W2, [W0]             ; Write PM low word into program latch
TBLWTH W3, [W0]             ; Write PM high byte into program latch
```

## EXAMPLE 5-4: LOADING THE WRITE BUFFERS – ‘C’ LANGUAGE CODE

```
// C example using MPLAB C30

#define NUM_INSTRUCTION_PER_ROW 64
int __attribute__((space(auto_psv))) progAddr = 0x1234 // Variable located in Pgm Memory
unsigned int offset;
unsigned int i;
unsigned int progData[2*NUM_INSTRUCTION_PER_ROW]; // Buffer of data to write

//Set up NVMCON for row programming
NVMCON = 0x4004; // Initialize NVMCON

//Set up pointer to the first memory location to be written
TBLPAG = __builtin_tblpage(&progAddr); // Initialize PM Page Boundary SFR
offset = __builtin_tbloffset(&progAddr); // Initialize lower word of address

//Perform TBLWT instructions to write necessary number of latches
for(i=0; i < 2*NUM_INSTRUCTION_PER_ROW; i++)
{
    __builtin_tblwtl(offset, progData[i++]); // Write to address low word
    __builtin_tblwth(offset, progData[i]); // Write to upper byte
    offset = offset + 2; // Increment address
}
```

# PIC24F16KA102 FAMILY

---

## EXAMPLE 5-5: INITIATING A PROGRAMMING SEQUENCE – ASSEMBLY LANGUAGE CODE

```
DISI    #5                                ; Block all interrupts
                                              for next 5 instructions

MOV     #0x55, W0
MOV     W0, NVMKEY                        ; Write the 55 key
MOV     #0xAA, W1
MOV     W1, NVMKEY                        ; Write the AA key
BSET    NVMCON, #WR                       ; Start the erase sequence
NOP                                           ; 2 NOPs required after setting WR
NOP                                           ;
BTSC    NVMCON, #15                       ; Wait for the sequence to be completed
BRA     $-2                                ;
```

## EXAMPLE 5-6: INITIATING A PROGRAMMING SEQUENCE – ‘C’ LANGUAGE CODE

```
// C example using MPLAB C30

asm("DISI #5");                          // Block all interrupts for next 5 instructions

__builtin_write_NVM();                    // Perform unlock sequence and set WR
```

## 6.0 DATA EEPROM MEMORY

**Note:** This data sheet summarizes the features of this group of PIC24F devices. It is not intended to be a comprehensive reference source. For more information on Data EEPROM, refer to the “PIC24F Family Reference Manual”, Section 5. “Data EEPROM” (DS39720).

The data EEPROM memory is a Nonvolatile Memory (NVM), separate from the program and volatile data RAM. Data EEPROM memory is based on the same Flash technology as program memory, and is optimized for both long retention and a higher number of erase/write cycles.

The data EEPROM is mapped to the top of the user program memory space, with the top address at program memory address, 7FFE00h to 7FFFFFFh. The size of the data EEPROM is 256 words in PIC24F16KA102 devices.

The data EEPROM is organized as 16-bit wide memory. Each word is directly addressable, and is readable and writable during normal operation over the entire VDD range.

Unlike the Flash program memory, normal program execution is not stopped during a data EEPROM program or erase operation.

The data EEPROM programming operations are controlled using the three NVM Control registers:

- NVMCON: Nonvolatile Memory Control Register
- NVMKEY: Nonvolatile Memory Key Register
- NVMADR: Nonvolatile Memory Address Register

### EXAMPLE 6-1: DATA EEPROM UNLOCK SEQUENCE

```
//Disable Interrupts For 5 instructions
asm volatile ("disi #5");
//Issue Unlock Sequence
asm volatile ("mov #0x55, W0      \n"
             "mov W0, NVMKEY      \n"
             "mov #0xAA, W1      \n"
             "mov W1, NVMKEY      \n");
// Perform Write/Erase operations
asm volatile ("bset NVMCON, #WR   \n"
             "nop                  \n"
             "nop                  \n");
```

## 6.1 NVMCON Register

The NVMCON register ([Register 6-1](#)) is also the primary control register for data EEPROM program/erase operations. The upper byte contains the control bits used to start the program or erase cycle, and the flag bit to indicate if the operation was successfully performed. The lower byte of NVMCOM configures the type of NVM operation that will be performed.

## 6.2 NVMKEY Register

The NVMKEY is a write-only register that is used to prevent accidental writes or erasures of data EEPROM locations.

To start any programming or erase sequence, the following instructions must be executed first, in the exact order provided:

1. Write 55h to NVMKEY.
2. Write AAh to NVMKEY.

After this sequence, a write will be allowed to the NVMCON register for one instruction cycle. In most cases, the user will simply need to set the WR bit in the NVMCON register to start the program or erase cycle. Interrupts should be disabled during the unlock sequence.

The MPLAB® C30 C compiler provides a defined library procedure (`builtin_write_nvm`) to perform the unlock sequence. [Example 6-1](#) illustrates how the unlock sequence can be performed with in-line assembly.

# PIC24F16KA102 FAMILY

## REGISTER 6-1: NVMCON: NONVOLATILE MEMORY CONTROL REGISTER

R/S-0, HC	R/W-0	R/W-0	R/W-0	U-0	U-0	U-0	U-0
WR	WREN	WRERR	PGMONLY	—	—	—	—
bit 15							bit 8

U-0	R/W-0	R/W-0	R/W-0	R/W-0	R/W-0	R/W-0	R/W-0
—	ERASE	NVMOP5	NVMOP4	NVMOP3	NVMOP2	NVMOP1	NVMOP0
bit 7							bit 0

<b>Legend:</b>	U = Unimplemented bit, read as '0'		
R = Readable bit	W = Writable bit	S = Settable bit	HC = Hardware Clearable bit
-n = Value at POR	'1' = Bit is set	'0' = Bit is cleared	x = Bit is unknown

- bit 15      **WR:** Write Control bit (program or erase)  
 1 = Initiates a data EEPROM erase or write cycle (can be set but not cleared in software)  
 0 = Write cycle is complete (cleared automatically by hardware)
- bit 14      **WREN:** Write Enable bit (erase or program)  
 1 = Enable an erase or program operation  
 0 = No operation allowed (device clears this bit on completion of the write/erase operation)
- bit 13      **WRERR:** Flash Error Flag bit  
 1 = A write operation is prematurely terminated (any  $\overline{\text{MCLR}}$  or WDT Reset during programming operation)  
 0 = The write operation completed successfully
- bit 12      **PGMONLY:** Program Only Enable bit  
 1 = Write operation is executed without erasing target address(es) first  
 0 = Automatic erase-before-write: write operations are preceded automatically by an erase of target address(es)
- bit 11-7    **Unimplemented:** Read as '0'
- bit 6        **ERASE:** Erase Operation Select bit  
 1 = Perform an erase operation when WR is set  
 0 = Perform a write operation when WR is set
- bit 5-0     **NVMOP<5:0>:** Programming Operation Command Byte bits  
Erase Operations (when ERASE bit is '1'):  
 011010 = Erase 8 words  
 011001 = Erase 4 words  
 011000 = Erase 1 word  
 0100xx = Erase entire data EEPROM  
Programming Operations (when ERASE bit is '0'):  
 001xx = Write 1 word

# PIC24F16KA102 FAMILY

## 6.3 NVM Address Register

As with Flash program memory, the NVM Address Registers, NVMADRU and NVMADR, form the 24-bit Effective Address (EA) of the selected row or word for data EEPROM operations. The NVMADRU register is used to hold the upper 8 bits of the EA, while the NVMADR register is used to hold the lower 16 bits of the EA. These registers are not mapped into the Special Function Register (SFR) space; instead, they directly capture the EA<23:0> of the last table write instruction that has been executed and selects the data EEPROM row to erase. Figure 6-1 depicts the program memory EA that is formed for programming and erase operations.

Like program memory operations, the Least Significant bit (LSb) of NVMADR is restricted to even addresses. This is because any given address in the data EEPROM space consists of only the lower word of the program memory width; the upper word, including the uppermost “phantom byte”, are unavailable. This means that the LSb of a data EEPROM address will always be ‘0’.

Similarly, the Most Significant bit (MSb) of NVMADRU is always ‘0’, since all addresses lie in the user program space.

**FIGURE 6-1: DATA EEPROM ADDRESSING WITH TBLPAG AND NVM ADDRESS REGISTERS**



## 6.4 Data EEPROM Operations

The EEPROM block is accessed using table read and write operations, similar to those used for program memory. The TBLWTH and TBLRDH instructions are not required for data EEPROM operations, since the memory is only 16 bits wide (data on the lower address is valid only). The following programming operations can be performed on the data EEPROM:

- Erase one, four or eight words
- Bulk erase the entire data EEPROM
- Write one word
- Read one word

**Note 1:** Unexpected results will be obtained should the user attempt to read the EEPROM while a programming or erase operation is underway.

- 2: The C30 C compiler includes library procedures to automatically perform the table read and table write operations, manage the Table Pointer and write buffers, and unlock and initiate memory write sequences. This eliminates the need to create assembler macros or time critical routines in C for each application.

The library procedures are used in the code examples detailed in the following sections. General descriptions of each process are provided for users who are not using the C30 compiler libraries.

# PIC24F16KA102 FAMILY

---

## 6.4.1 ERASE DATA EEPROM

The data EEPROM can be fully erased, or can be partially erased, at three different sizes: one word, four words or eight words. The bits, NVMOP<1:0> (NVMCON<1:0>), decide the number of words to be erased. To erase partially from the data EEPROM, the following sequence must be followed:

1. Configure NVMCON to erase the required number of words: one, four or eight.
2. Load TBLPAG and WREG with the EEPROM address to be erased.
3. Clear NVMIF status bit and enable NVM interrupt (optional).
4. Write the key sequence to NVMKEY.
5. Set the WR bit to begin erase cycle.
6. Either poll the WR bit or wait for the NVM interrupt (NVMIF set).

A typical erase sequence is provided in [Example 6-2](#). This example shows how to do a one-word erase. Similarly, a four-word erase and an eight-word erase can be done. This example uses 'C' library procedures to manage the Table Pointer (`builtin_tblpage` and `builtin_tbloffset`) and the Erase Page Pointer (`builtin_tblwtl`). The memory unlock sequence (`builtin_write_NVM`) also sets the WR bit to initiate the operation and returns control when complete.

### EXAMPLE 6-2: SINGLE-WORD ERASE

```
int __attribute__((space(eedata))) eeData = 0x1234; // Variable located in EEPROM
unsigned int offset;

// Set up NVMCON to erase one word of data EEPROM
NVMCON = 0x4058;

// Set up a pointer to the EEPROM location to be erased
TBLPAG = __builtin_tblpage(&eeData); // Initialize EE Data page pointer
offset = __builtin_tbloffset(&eeData); // Initialize lower word of address
__builtin_tblwtl(offset, 0); // Write EEPROM data to write latch

asm volatile ("disi #5"); // Disable Interrupts For 5 Instructions
__builtin_write_NVM(); // Issue Unlock Sequence & Start Write Cycle
```

# PIC24F16KA102 FAMILY

## 6.4.1.1 Data EEPROM Bulk Erase

To erase the entire data EEPROM (bulk erase), the address registers do not need to be configured because this operation affects the entire data EEPROM. The following sequence helps in performing bulk erase:

1. Configure NVMCON to Bulk Erase mode.
2. Clear NVMIF status bit and enable NVM interrupt (optional).
3. Write the key sequence to NVMKEY.
4. Set the WR bit to begin erase cycle.
5. Either poll the WR bit or wait for the NVM interrupt (NVMIF is set).

A typical bulk erase sequence is provided in [Example 6-3](#).

## 6.4.2 SINGLE-WORD WRITE

To write a single word in the data EEPROM, the following sequence must be followed:

1. Erase one data EEPROM word (as mentioned in [Section 6.4.1 "Erase Data EEPROM"](#)) if the PGMONLY bit (NVMCON<12>) is set to '1'.
2. Write the data word into the data EEPROM latch.
3. Program the data word into the EEPROM:
  - Configure the NVMCON register to program one EEPROM word (NVMCON<5:0> = 0001xxx).
  - Clear NVMIF status bit and enable NVM interrupt (optional).
  - Write the key sequence to NVMKEY.
  - Set the WR bit to begin erase cycle.
  - Either poll the WR bit or wait for the NVM interrupt (NVMIF is set).
  - To get cleared, wait until NVMIF is set.

A typical single-word write sequence is provided in [Example 6-4](#).

### EXAMPLE 6-3: DATA EEPROM BULK ERASE

```
// Set up NVMCON to bulk erase the data EEPROM
NVMCON = 0x4050;

// Disable Interrupts For 5 Instructions
asm volatile ("disi #5");

// Issue Unlock Sequence and Start Erase Cycle
__builtin_write_NVM();
```

### EXAMPLE 6-4: SINGLE-WORD WRITE TO DATA EEPROM

```
int __attribute__((space(eedata))) eeData = 0x1234; // Variable located in EEPROM, declared as a
                                                    // global variable.
int newData; // New data to write to EEPROM
unsigned int offset;

// Set up NVMCON to erase one word of data EEPROM
NVMCON = 0x4004;

// Set up a pointer to the EEPROM location to be erased
TBLPAG = __builtin_tblpage(&eeData); // Initialize EE Data page pointer
offset = __builtin_tbloffset(&eeData); // Initialize lower word of address
__builtin_tblwtl(offset, newData); // Write EEPROM data to write latch

asm volatile ("disi #5"); // Disable Interrupts For 5 Instructions
__builtin_write_NVM(); // Issue Unlock Sequence & Start Write Cycle
```

# PIC24F16KA102 FAMILY

---

## 6.4.3 READING THE DATA EEPROM

To read a word from data EEPROM, the table read instruction is used. Since the EEPROM array is only 16 bits wide, only the `TBLRDL` instruction is needed. The read operation is performed by loading `TBLPAG` and `WREG` with the address of the EEPROM location, followed by a `TBLRDL` instruction.

A typical read sequence, using the Table Pointer management (`builtin_tblpage` and `builtin_tbloffset`) and table read (`builtin_tblrld`) procedures from the C30 compiler library, is provided in [Example 6-5](#).

Program Space Visibility (PSV) can also be used to read locations in the data EEPROM.

### EXAMPLE 6-5: READING THE DATA EEPROM USING THE `TBLRD` COMMAND

```
int __attribute__((space(eedata))) eeData = 0x1234;    // Variable located in EEPROM, declared
                                                    // as a global variable

int data;      // Data read from EEPROM
unsigned int offset;

// Set up a pointer to the EEPROM location to be erased
TBLPAG = __builtin_tblpage(&eeData);                // Initialize EE Data page pointer
offset = __builtin_tbloffset(&eeData);               // Initialize lower word of address
data = __builtin_tblrld(offset);                     // Write EEPROM data to write latch
```



# PIC24F16KA102 FAMILY

## 7.0 RESETS

**Note:** This data sheet summarizes the features of this group of PIC24F devices. It is not intended to be a comprehensive reference source. For more information on Resets, refer to the “PIC24F Family Reference Manual”, Section 40. “Reset with Programmable Brown-out Reset” (DS39728).

The Reset module combines all Reset sources and controls the device Master Reset Signal,  $\overline{\text{SYSRST}}$ . The following is a list of device Reset sources:

- POR: Power-on Reset
- MCLR: Pin Reset
- SWR: RESET Instruction
- WDTR: Watchdog Timer Reset
- BOR: Brown-out Reset
- Low-Power BOR/Deep Sleep BOR
- TRAPR: Trap Conflict Reset
- IOPUWR: Illegal Opcode Reset
- UWR: Uninitialized W Register Reset

Figure 7-1 displays a simplified block diagram of the Reset module.

Any active source of Reset will make the  $\overline{\text{SYSRST}}$  signal active. Many registers associated with the CPU and peripherals are forced to a known Reset state. Most registers are unaffected by a Reset; their status is unknown on a Power-on Reset (POR) and unchanged by all other Resets.

**Note:** Refer to the specific peripheral or CPU section of this manual for register Reset states.

All types of device Reset will set a corresponding status bit in the RCON register to indicate the type of Reset (see Register 7-1). A POR will clear all bits except for the BOR and POR bits (RCON<1:0>) which are set. The user may set or clear any bit at any time during code execution. The RCON bits only serve as status bits. Setting a particular Reset status bit in software will not cause a device Reset to occur.

The RCON register also has other bits associated with the Watchdog Timer (WDT) and device power-saving states. The function of these bits is discussed in other sections of this manual.

**Note:** The status bits in the RCON register should be cleared after they are read so that the next RCON register value, after a device Reset, will be meaningful.

FIGURE 7-1: RESET SYSTEM BLOCK DIAGRAM



# PIC24F16KA102 FAMILY

## REGISTER 7-1: RCON: RESET CONTROL REGISTER<sup>(1)</sup>

R/W-0, HS	R/W-0, HS	R/W-0	U-0	U-0	R/C-0, HS	R/W-0, HS	R/W-0
TRAPR	IOPUWR	SBOREN	—	—	DPSLP	CM	PMSLP
bit 15						bit 8	

R/W-0, HS	R/W-0, HS	R/W-0, HS	R/W-0, HS	R/W-0, HS	R/W-0, HS	R/W-1, HS	R/W-1, HS
EXTR	SWR	SWDTEN <sup>(2)</sup>	WDTO	SLEEP	IDLE	BOR	POR
bit 7						bit 0	

<b>Legend:</b>	C = Clearable bit	HS = Hardware Settable bit
R = Readable bit	W = Writable bit	U = Unimplemented bit, read as '0'
-n = Value at POR	'1' = Bit is set	'0' = Bit is cleared      x = Bit is unknown

- bit 15      **TRAPR:** Trap Reset Flag bit  
 1 = A Trap Conflict Reset has occurred  
 0 = A Trap Conflict Reset has not occurred
- bit 14      **IOPUWR:** Illegal Opcode or Uninitialized W Access Reset Flag bit  
 1 = An illegal opcode detection, an illegal address mode or uninitialized W register used as an Address Pointer caused a Reset  
 0 = An illegal opcode or uninitialized W Reset has not occurred
- bit 13      **SBOREN:** Software Enable/Disable of BOR bit  
 1 = BOR is turned on in software  
 0 = BOR is turned off in software
- bit 12-11      **Unimplemented:** Read as '0'
- bit 10      **DPSLP:** Deep Sleep Mode Flag bit  
 1 = Deep Sleep has occurred  
 0 = Deep Sleep has not occurred
- bit 9      **CM:** Configuration Word Mismatch Reset Flag bit  
 1 = A Configuration Word Mismatch has occurred  
 0 = A Configuration Word Mismatch has not occurred
- bit 8      **PMSLP:** Program Memory Power During Sleep bit  
 1 = Program memory bias voltage remains powered during Sleep  
 0 = Program memory bias voltage is powered down during Sleep
- bit 7      **EXTR:** External Reset ( $\overline{\text{MCLR}}$ ) Pin bit  
 1 = A Master Clear (pin) Reset has occurred  
 0 = A Master Clear (pin) Reset has not occurred
- bit 6      **SWR:** Software Reset (Instruction) Flag bit  
 1 = A RESET instruction has been executed  
 0 = A RESET instruction has not been executed
- bit 5      **SWDTEN:** Software Enable/Disable of WDT bit<sup>(2)</sup>  
 1 = WDT is enabled  
 0 = WDT is disabled
- bit 4      **WDTO:** Watchdog Timer Time-out Flag bit  
 1 = WDT time-out has occurred  
 0 = WDT time-out has not occurred

- Note 1:** All of the Reset status bits may be set or cleared in software. Setting one of these bits in software does not cause a device Reset.
- 2:** If the FWDTEN Configuration bit is '1' (unprogrammed), the WDT is always enabled, regardless of the SWDTEN bit setting.

# PIC24F16KA102 FAMILY

## REGISTER 7-1: RCON: RESET CONTROL REGISTER<sup>(1)</sup> (CONTINUED)

bit 3	<b>SLEEP:</b> Wake-up from Sleep Flag bit 1 = Device has been in Sleep mode 0 = Device has not been in Sleep mode
bit 2	<b>IDLE:</b> Wake-up from Idle Flag bit 1 = Device has been in Idle mode 0 = Device has not been in Idle mode
bit 1	<b>BOR:</b> Brown-out Reset Flag bit 1 = A Brown-out Reset has occurred (the BOR is also set after a POR) 0 = A Brown-out Reset has not occurred
bit 0	<b>POR:</b> Power-on Reset Flag bit 1 = A Power-up Reset has occurred 0 = A Power-up Reset has not occurred

**Note 1:** All of the Reset status bits may be set or cleared in software. Setting one of these bits in software does not cause a device Reset.

**2:** If the FWDTEN Configuration bit is '1' (unprogrammed), the WDT is always enabled, regardless of the SWDTEN bit setting.

**TABLE 7-1: RESET FLAG BIT OPERATION**

Flag Bit	Setting Event	Clearing Event
TRAPR (RCON<15>)	Trap Conflict Event	POR
IOPUWR (RCON<14>)	Illegal Opcode or Uninitialized W Register Access	POR
CM (RCON<9>)	Configuration Mismatch Reset	POR
EXTR (RCON<7>)	MCLR Reset	POR
SWR (RCON<6>)	RESET Instruction	POR
WDTO (RCON<4>)	WDT Time-out	PWRSVAV Instruction, POR
SLEEP (RCON<3>)	PWRSVAV #SLEEP Instruction	POR
IDLE (RCON<2>)	PWRSVAV #IDLE Instruction	POR
BOR (RCON<1>)	POR, BOR	—
POR (RCON<0>)	POR	—
DPSLP (RCON<10>)	PWRSVAV #SLEEP instruction with DSCON <DSEN> set	POR

**Note:** All Reset flag bits may be set or cleared by the user software.

# PIC24F16KA102 FAMILY

## 7.1 Clock Source Selection at Reset

If clock switching is enabled, the system clock source at device Reset is chosen, as shown in [Table 7-2](#). If clock switching is disabled, the system clock source is always selected according to the oscillator Configuration bits. Refer to [Section 9.0 “Oscillator Configuration”](#) for further details.

**TABLE 7-2: OSCILLATOR SELECTION vs. TYPE OF RESET (CLOCK SWITCHING ENABLED)**

Reset Type	Clock Source Determinant
POR	FNOSC Configuration bits (FNOSC<10:8>)
BOR	
$\overline{\text{MCLR}}$	COSC Control bits (OSCCON<14:12>)
WDTO	
SWR	

## 7.2 Device Reset Times

The Reset times for various types of device Reset are summarized in [Table 7-3](#). Note that the system Reset signal,  $\overline{\text{SYSRST}}$ , is released after the POR and PWRT delay times expire.

The time at which the device actually begins to execute code will also depend on the system oscillator delays, which include the Oscillator Start-up Timer (OST) and the PLL lock time. The OST and PLL lock times occur in parallel with the applicable  $\overline{\text{SYSRST}}$  delay times.

The FSCM delay determines the time at which the FSCM begins to monitor the system clock source after the  $\overline{\text{SYSRST}}$  signal is released.

**TABLE 7-3: RESET DELAY TIMES FOR VARIOUS DEVICE RESETS**

Reset Type	Clock Source	$\overline{\text{SYSRST}}$ Delay	System Clock Delay	Notes
POR <sup>(6)</sup>	EC	TPOR + TPWRT	—	1, 2
	FRC, FRCDIV	TPOR + TPWRT	TFRC	1, 2, 3
	LPRC	TPOR + TPWRT	TLPRC	1, 2, 3
	ECPLL	TPOR + TPWRT	TLOCK	1, 2, 4
	FRCPLL	TPOR + TPWRT	TFRC + TLOCK	1, 2, 3, 4
	XT, HS, SOSC	TPOR + TPWRT	TOST	1, 2, 5
	XTPLL, HSPLL	TPOR + TPWRT	TOST + TLOCK	1, 2, 4, 5
BOR	EC	TPWRT	—	2
	FRC, FRCDIV	TPWRT	TFRC	2, 3
	LPRC	TPWRT	TLPRC	2, 3
	ECPLL	TPWRT	TLOCK	2, 4
	FRCPLL	TPWRT	TFRC + TLOCK	2, 3, 4
	XT, HS, SOSC	TPWRT	TOST	2, 5
	XTPLL, HSPLL	TPWRT	TFRC + TLOCK	2, 3, 4
All Others	Any Clock	—	—	None

**Note 1:** TPOR = Power-on Reset (POR) delay.

**2:** TPWRT = 64 ms nominal if the Power-up Timer (PWRT) is enabled; otherwise, it is zero.

**3:** TFRC and TLPRC = RC oscillator start-up times.

**4:** TLOCK = PLL lock time.

**5:** TOST = Oscillator Start-up Timer (OST). A 10-bit counter waits 1024 oscillator periods before releasing the oscillator clock to the system.

**6:** If Two-Speed Start-up is enabled, regardless of the primary oscillator selected, the device starts with FRC, and in such cases, FRC start-up time is valid.

**Note:** For detailed operating frequency and timing specifications, see [Section 29.0 “Electrical Characteristics”](#).

## 7.2.1 POR AND LONG OSCILLATOR START-UP TIMES

The oscillator start-up circuitry and its associated delay timers are not linked to the device Reset delays that occur at power-up. Some crystal circuits (especially low-frequency crystals) will have a relatively long start-up time. Therefore, one or more of the following conditions is possible after  $\overline{\text{SYSRST}}$  is released:

- The oscillator circuit has not begun to oscillate.
- The Oscillator Start-up Timer (OST) has not expired (if a crystal oscillator is used).
- The PLL has not achieved a lock (if PLL is used).

The device will not begin to execute code until a valid clock source has been released to the system. Therefore, the oscillator and PLL start-up delays must be considered when the Reset delay time must be known.

## 7.2.2 FAIL-SAFE CLOCK MONITOR (FSCM) AND DEVICE RESETS

If the FSCM is enabled, it will begin to monitor the system clock source when  $\overline{\text{SYSRST}}$  is released. If a valid clock source is not available at this time, the device will automatically switch to the FRC oscillator and the user can switch to the desired crystal oscillator in the Trap Service Routine (TSR).

## 7.3 Special Function Register Reset States

Most of the Special Function Registers (SFRs) associated with the PIC24F CPU and peripherals are reset to a particular value at a device Reset. The SFRs are grouped by their peripheral or CPU function and their Reset values are specified in each section of this manual.

The Reset value for each SFR does not depend on the type of Reset with the exception of four registers. The Reset value for the Reset Control register, RCON, will depend on the type of device Reset. The Reset value for the Oscillator Control register, OSCCON, will depend on the type of Reset and the programmed values of the FNOSC bits in the Flash Configuration Word (FOSCSEL); see [Table 7-2](#). The RCFGAL and NVMCON registers are only affected by a POR.

## 7.4 Deep Sleep BOR (DSBOR)

Deep Sleep BOR is a very low-power BOR circuitry, used when the device is in Deep Sleep mode. Due to low-current consumption, accuracy may vary.

The DSBOR trip point is around 2.0V. DSBOR is enabled by configuring  $\text{DSBORN}(\text{FDS}\langle 6 \rangle) = 1$ . DSBORN will re-arm the POR to ensure the device will reset if  $V_{DD}$  drops below the POR threshold.

## 7.5 Brown-out Reset (BOR)

The PIC24F16KA102 family devices implement a BOR circuit, which provides the user several configuration and power-saving options. The BOR is controlled by the  $\text{BORV}\langle 1:0 \rangle$  and  $\text{BOREN}\langle 1:0 \rangle$  Configuration bits ( $\text{FPOR}\langle 6:5, 1:0 \rangle$ ). There are a total of four BOR configurations, which are provided in [Table 7-3](#).

The BOR threshold is set by the  $\text{BORV}\langle 1:0 \rangle$  bits. If BOR is enabled (any values of  $\text{BOREN}\langle 1:0 \rangle$ , except '00'), any drop of  $V_{DD}$  below the set threshold point will reset the device. The chip will remain in BOR until  $V_{DD}$  rises above threshold.

If the Power-up Timer is enabled, it will be invoked after  $V_{DD}$  rises above the threshold. Then, it will keep the chip in Reset for an additional time delay,  $T_{PWRT}$ , if  $V_{DD}$  drops below the threshold while the Power-up Timer is running. The chip goes back into a BOR and the Power-up Timer will be initialized. Once  $V_{DD}$  rises above the threshold, the Power-up Timer will execute the additional time delay.

BOR and the Power-up Timer are independently configured. Enabling the BOR Reset does not automatically enable the PWRT.

### 7.5.1 SOFTWARE ENABLED BOR

When  $\text{BOREN}\langle 1:0 \rangle = 01$ , the BOR can be enabled or disabled by the user in software. This is done with the control bit,  $\text{SBOREN}(\text{RCON}\langle 13 \rangle)$ . Setting  $\text{SBOREN}$  enables the BOR to function as previously described. Clearing the  $\text{SBOREN}$  disables the BOR entirely. The  $\text{SBOREN}$  bit operates only in this mode; otherwise, it is read as '0'.

Placing BOR under software control gives the user the additional flexibility of tailoring the application to its environment without having to reprogram the device to change the BOR configuration. It also allows the user to tailor the incremental current that the BOR consumes. While the BOR current is typically very small, it may have some impact in low-power applications.

**Note:** Even when the BOR is under software control, the BOR Reset voltage level is still set by the  $\text{BORV}\langle 1:0 \rangle$  Configuration bits; it can not be changed in software.

# PIC24F16KA102 FAMILY

---

## 7.5.2 DETECTING BOR

When BOR is enabled, the BOR bit (RCON<1>) is always reset to '1' on any BOR or POR event. This makes it difficult to determine if a BOR event has occurred just by reading the state of BOR alone. A more reliable method is to simultaneously check the state of both POR and BOR. This assumes that the POR and BOR bits are reset to '0' in the software immediately after any POR event. If the BOR bit is '1' while the POR bit is '0', it can be reliably assumed that a BOR event has occurred.

<p><b>Note:</b> Even when the device exits from Deep Sleep mode, both the POR and BOR are set.</p>
----------------------------------------------------------------------------------------------------

## 7.5.3 DISABLING BOR IN SLEEP MODE

When BOREN<1:0> = 10, BOR remains under hardware control and operates as previously described. However, whenever the device enters Sleep mode, BOR is automatically disabled. When the device returns to any other operating mode, BOR is automatically re-enabled.

This mode allows for applications to recover from brown-out situations, while actively executing code, when the device requires BOR protection the most. At the same time, it saves additional power in Sleep mode by eliminating the small incremental BOR current.

## 8.0 INTERRUPT CONTROLLER

**Note:** This data sheet summarizes the features of this group of PIC24F devices. It is not intended to be a comprehensive reference source. For more information on the Interrupt Controller, refer to the “PIC24F Family Reference Manual”, Section 8. “Interrupts” (DS39707).

The PIC24F interrupt controller reduces the numerous peripheral interrupt request signals to a single interrupt request signal to the CPU. It has the following features:

- Up to eight processor exceptions and software traps
- Seven user-selectable priority levels
- Interrupt Vector Table (IVT) with up to 118 vectors
- Unique vector for each interrupt or exception source
- Fixed priority within a specified user priority level
- Alternate Interrupt Vector Table (AIVT) for debug support
- Fixed interrupt entry and return latencies

### 8.1 Interrupt Vector (IVT) Table

The IVT is displayed in Figure 8-1. The IVT resides in the program memory, starting at location, 000004h. The IVT contains 126 vectors, consisting of eight non-maskable trap vectors, plus, up to 118 sources of interrupt. In general, each interrupt source has its own vector. Each interrupt vector contains a 24-bit wide address. The value programmed into each interrupt vector location is the starting address of the associated Interrupt Service Routine (ISR).

Interrupt vectors are prioritized in terms of their natural priority; this is linked to their position in the vector table. All other things being equal, lower addresses have a higher natural priority. For example, the interrupt associated with Vector 0 will take priority over interrupts at any other vector address.

PIC24F16KA102 family devices implement non-maskable traps and unique interrupts; these are summarized in Table 8-1 and Table 8-2.

### 8.1.1 ALTERNATE INTERRUPT VECTOR TABLE (AIVT)

The Alternate Interrupt Vector Table (AIVT) is located after the IVT, as displayed in Figure 8-1. Access to the AIVT is provided by the ALTIVT control bit (INTCON2<15>). If the ALTIVT bit is set, all interrupt and exception processes will use the alternate vectors instead of the default vectors. The alternate vectors are organized in the same manner as the default vectors.

The AIVT supports emulation and debugging efforts by providing a means to switch between an application and a support environment without requiring the interrupt vectors to be reprogrammed. This feature also enables switching between applications for evaluation of different software algorithms at run-time. If the AIVT is not needed, the AIVT should be programmed with the same addresses used in the IVT.

## 8.2 Reset Sequence

A device Reset is not a true exception because the interrupt controller is not involved in the Reset process. The PIC24F devices clear their registers in response to a Reset, which forces the Program Counter (PC) to zero. The microcontroller then begins program execution at location, 000000h. The user programs a GOTO instruction at the Reset address, which redirects the program execution to the appropriate start-up routine.

**Note:** Any unimplemented or unused vector locations in the IVT and AIVT should be programmed with the address of a default interrupt handler routine that contains a RESET instruction.

# PIC24F16KA102 FAMILY

**FIGURE 8-1: PIC24F INTERRUPT VECTOR TABLE**





# PIC24F16KA102 FAMILY

**TABLE 8-1: TRAP VECTOR DETAILS**

Vector Number	IVT Address	AIVT Address	Trap Source
0	000004h	000104h	Reserved
1	000006h	000106h	Oscillator Failure
2	000008h	000108h	Address Error
3	00000Ah	00010Ah	Stack Error
4	00000Ch	00010Ch	Math Error
5	00000Eh	00010Eh	Reserved
6	000010h	000110h	Reserved
7	000012h	000112h	Reserved

**TABLE 8-2: IMPLEMENTED INTERRUPT VECTORS**

Interrupt Source	Vector Number	IVT Address	AIVT Address	Interrupt Bit Locations		
				Flag	Enable	Priority
ADC1 Conversion Done	13	00002Eh	00012Eh	IFS0<13>	IEC0<13>	IPC3<6:4>
Comparator Event	18	000038h	000138h	IFS1<2>	IEC1<2>	IPC4<10:8>
CRC Generator	67	00009Ah	00019Ah	IFS4<3>	IEC4<3>	IPC16<14:12>
CTMU	77	0000AEh	0001AEh	IFS4<13>	IEC4<13>	IPC19<6:4>
External Interrupt 0	0	000014h	000114h	IFS0<0>	IEC0<0>	IPC0<2:0>
External Interrupt 1	20	00003Ch	00013Ch	IFS1<4>	IEC1<4>	IPC5<2:0>
External Interrupt 2	29	00004Eh	00014Eh	IFS1<13>	IEC1<13>	IPC7<6:4>
I2C1 Master Event	17	000036h	000136h	IFS1<1>	IEC1<1>	IPC4<6:4>
I2C1 Slave Event	16	000034h	000134h	IFS1<0>	IEC1<0>	IPC4<2:0>
Input Capture 1	1	000016h	000116h	IFS0<1>	IEC0<1>	IPC0<6:4>
Input Change Notification	19	00003Ah	00013Ah	IFS1<3>	IEC1<3>	IPC4<14:12>
HLVD High/Low-Voltage Detect	72	0000A4h	0001A4h	IFS4<8>	IEC4<8>	IPC17<2:0>
NVM – NVM Write Complete	15	000032h	000132h	IFS0<15>	IEC0<15>	IPC3<14:12>
Output Compare 1	2	000018h	000118h	IFS0<2>	IEC0<2>	IPC0<10:8>
Real-Time Clock/Calendar	62	000090h	000190h	IFS3<14>	IEC3<14>	IPC15<10:8>
SPI1 Error	9	000026h	000126h	IFS0<9>	IEC0<9>	IPC2<6:4>
SPI1 Event	10	000028h	000128h	IFS0<10>	IEC0<10>	IPC2<10:8>
Timer1	3	00001Ah	00011Ah	IFS0<3>	IEC0<3>	IPC0<14:12>
Timer2	7	000022h	000122h	IFS0<7>	IEC0<7>	IPC1<14:12>
Timer3	8	000024h	000124h	IFS0<8>	IEC0<8>	IPC2<2:0>
UART1 Error	65	000096h	000196h	IFS4<1>	IEC4<1>	IPC16<6:4>
UART1 Receiver	11	00002Ah	00012Ah	IFS0<11>	IEC0<11>	IPC2<14:12>
UART1 Transmitter	12	00002Ch	00012Ch	IFS0<12>	IEC0<12>	IPC3<2:0>
UART2 Error	66	000098h	000198h	IFS4<2>	IEC4<2>	IPC16<10:8>
UART2 Receiver	30	000050h	000150h	IFS1<14>	IEC1<14>	IPC7<10:8>
UART2 Transmitter	31	000052h	000152h	IFS1<15>	IEC1<15>	IPC7<14:12>

# PIC24F16KA102 FAMILY

---

## 8.3 Interrupt Control and Status Registers

The PIC24F16KA102 family of devices implements a total of 22 registers for the interrupt controller:

- INTCON1
- INTCON2
- IFS0, IFS1, IFS3 and IFS4
- IEC0, IEC1, IEC3 and IEC4
- IPC0 through IPC5, IPC7 and IPC15 through IPC19
- INTTREG

Global interrupt control functions are controlled from INTCON1 and INTCON2. INTCON1 contains the Interrupt Nesting Disable (NSTDIS) bit, as well as the control and status flags for the processor trap sources. The INTCON2 register controls the external interrupt request signal behavior and the use of the AIV table.

The IFSx registers maintain all of the interrupt request flags. Each source of interrupt has a status bit, which is set by the respective peripherals, or external signal, and is cleared via software.

The IECx registers maintain all of the interrupt enable bits. These control bits are used to individually enable interrupts from the peripherals or external signals.

The IPCx registers are used to set the interrupt priority level for each source of interrupt. Each user interrupt source can be assigned to one of eight priority levels.

The INTTREG register contains the associated interrupt vector number and the new CPU interrupt priority level, which are latched into the Vector Number (VECNUM<6:0>) and the Interrupt Level (ILR<3:0>) bit fields in the INTTREG register. The new interrupt priority level is the priority of the pending interrupt.

The interrupt sources are assigned to the IFSx, IECx and IPCx registers in the same sequence listed in [Table 8-2](#). For example, the INT0 (External Interrupt 0) is depicted as having a vector number and a natural order priority of 0. Thus, the INT0IF status bit is found in IFS0<0>, the INT0IE enable bit in IEC0<0> and the INT0IP<2:0> priority bits in the first position of IPC0 (IPC0<2:0>).

Although they are not specifically part of the interrupt control hardware, two of the CPU control registers contain bits that control interrupt functionality. The ALU STATUS register (SR) contains the IPL<2:0> bits (SR<7:5>). These indicate the current CPU interrupt priority level. The user may change the current CPU priority level by writing to the IPL bits.

The CORCON register contains the IPL3 bit, which together with IPL<2:0>, also indicates the current CPU priority level. IPL3 is a read-only bit so that the trap events cannot be masked by the user's software.

All interrupt registers are described in [Register 8-1](#) through [Register 8-21](#), in the following sections.

# PIC24F16KA102 FAMILY

## REGISTER 8-1: SR: ALU STATUS REGISTER

U-0	U-0	U-0	U-0	U-0	U-0	U-0	R-0, HSC
—	—	—	—	—	—	—	DC <sup>(1)</sup>
bit 15							bit 8

R/W-0, HSC	R/W-0, HSC	R/W-0, HSC	R-0, HSC	R/W-0, HSC	R/W-0, HSC	R/W-0, HSC	R/W-0, HSC
IPL2 <sup>(2,3)</sup>	IPL1 <sup>(2,3)</sup>	IPL0 <sup>(2,3)</sup>	RA <sup>(1)</sup>	N <sup>(1)</sup>	OV <sup>(1)</sup>	Z <sup>(1)</sup>	C <sup>(1)</sup>
bit 7							bit 0

<b>Legend:</b>	HSC = Hardware Settable/Clearable bit
R = Readable bit	W = Writable bit
-n = Value at POR	'1' = Bit is set
	'0' = Bit is cleared
	x = Bit is unknown
	U = Unimplemented bit, read as '0'

bit 15-9 **Unimplemented:** Read as '0'

bit 7-5 **IPL<2:0>:** CPU Interrupt Priority Level Status bits<sup>(2,3)</sup>

- 111 = CPU interrupt priority level is 7 (15); user interrupts disabled
- 110 = CPU interrupt priority level is 6 (14)
- 101 = CPU interrupt priority level is 5 (13)
- 100 = CPU interrupt priority level is 4 (12)
- 011 = CPU interrupt priority level is 3 (11)
- 010 = CPU interrupt priority level is 2 (10)
- 001 = CPU interrupt priority level is 1 (9)
- 000 = CPU interrupt priority level is 0 (8)

- Note 1:** See [Register 3-1](#) for the description of these bits, which are not dedicated to interrupt control functions.
- Note 2:** The IPL bits are concatenated with the IPL3 bit (CORCON<3>) to form the CPU interrupt priority level. The value in parentheses indicates the interrupt priority level if IPL3 = 1.
- Note 3:** The IPL Status bits are read-only when NSTDIS (INTCON1<15>) = 1.

**Note:** Bit 8 and Bits 4 through 0 are described in [Section 3.0 "CPU"](#).

# PIC24F16KA102 FAMILY

## REGISTER 8-2: CORCON: CPU CONTROL REGISTER

U-0	U-0	U-0	U-0	U-0	U-0	U-0	U-0
—	—	—	—	—	—	—	—
bit 15							bit 8

U-0	U-0	U-0	U-0	R/C-0, HSC	R/W-0	U-0	U-0
—	—	—	—	IPL3 <sup>(2)</sup>	PSV <sup>(1)</sup>	—	—
bit 7							bit 0

<b>Legend:</b>	C = Clearable bit	HSC = Hardware Settable/Clearable bit
R = Readable bit	W = Writable bit	U = Unimplemented bit, read as '0'
-n = Value at POR	'1' = Bit is set	'0' = Bit is cleared      x = Bit is unknown

- bit 15-4      **Unimplemented:** Read as '0'
- bit 3        **IPL3:** CPU Interrupt Priority Level Status bit<sup>(2)</sup>
  - 1 = CPU interrupt priority level is greater than 7
  - 0 = CPU interrupt priority level is 7 or less
- bit 1-0      **Unimplemented:** Read as '0'

- Note 1:** See [Register 3-2](#) for the description of this bit, which is not dedicated to interrupt control functions.
- 2:** The IPL3 bit is concatenated with the IPL<2:0> bits (SR<7:5>) to form the CPU interrupt priority level.

**Note:** Bit 2 is described in [Section 3.0 "CPU"](#).

# PIC24F16KA102 FAMILY

## REGISTER 8-3: INTCON1: INTERRUPT CONTROL REGISTER 1

R/W-0	U-0	U-0	U-0	U-0	U-0	U-0	U-0
NSTDIS	—	—	—	—	—	—	—
bit 15							bit 8

U-0	U-0	U-0	R/W-0, HS	R/W-0, HS	R/W-0, HS	R/W-0, HS	U-0
—	—	—	MATHERR	ADDRERR	STKERR	OSCFAIL	—
bit 7							bit 0

<b>Legend:</b>	HS = Hardware Settable bit
R = Readable bit	W = Writable bit
U = Unimplemented bit, read as '0'	
-n = Value at POR	'1' = Bit is set
	'0' = Bit is cleared
	x = Bit is unknown

- bit 15      **NSTDIS:** Interrupt Nesting Disable bit  
                  1 = Interrupt nesting is disabled  
                  0 = Interrupt nesting is enabled
- bit 14-5    **Unimplemented:** Read as '0'
- bit 4        **MATHERR:** Arithmetic Error Trap Status bit  
                  1 = Overflow trap has occurred  
                  0 = Overflow trap has not occurred
- bit 3        **ADDRERR:** Address Error Trap Status bit  
                  1 = Address error trap has occurred  
                  0 = Address error trap has not occurred
- bit 2        **STKERR:** Stack Error Trap Status bit  
                  1 = Stack error trap has occurred  
                  0 = Stack error trap has not occurred
- bit 1        **OSCFAIL:** Oscillator Failure Trap Status bit  
                  1 = Oscillator failure trap has occurred  
                  0 = Oscillator failure trap has not occurred
- bit 0        **Unimplemented:** Read as '0'

# PIC24F16KA102 FAMILY

## REGISTER 8-4: INTCON2: INTERRUPT CONTROL REGISTER2

R/W-0	R-0, HSC	U-0	U-0	U-0	U-0	U-0	U-0
ALTIVT	DISI	—	—	—	—	—	—
bit 15							bit 8

U-0	U-0	U-0	U-0	U-0	R/W-0	R/W-0	R/W-0
—	—	—	—	—	INT2EP	INT1EP	INT0EP
bit 7						bit 0	

<b>Legend:</b>	HSC = Hardware Settable/Clearable bit		
R = Readable bit	W = Writable bit	U = Unimplemented bit, read as '0'	
-n = Value at POR	'1' = Bit is set	'0' = Bit is cleared	x = Bit is unknown

- bit 15      **ALTIVT:** Enable Alternate Interrupt Vector Table bit  
             1 = Use Alternate Interrupt Vector Table  
             0 = Use standard (default) vector table
- bit 14      **DISI:** DISI Instruction Status bit  
             1 = DISI instruction is active  
             0 = DISI instruction is not active
- bit 13-3    **Unimplemented:** Read as '0'
- bit 2        **INT2EP:** External Interrupt 2 Edge Detect Polarity Select bit  
             1 = Interrupt on negative edge  
             0 = Interrupt on positive edge
- bit 1        **INT1EP:** External Interrupt 1 Edge Detect Polarity Select bit  
             1 = Interrupt on negative edge  
             0 = Interrupt on positive edge
- bit 0        **INT0EP:** External Interrupt 0 Edge Detect Polarity Select bit  
             1 = Interrupt on negative edge  
             0 = Interrupt on positive edge

# PIC24F16KA102 FAMILY

## REGISTER 8-5: IFS0: INTERRUPT FLAG STATUS REGISTER 0

R/W-0, HS	U-0	R/W-0, HS	R/W-0, HS	R/W-0, HS	R/W-0, HS	R/W-0, HS	R/W-0, HS
NVMIF	—	AD1IF	U1TXIF	U1RXIF	SPI1IF	SPF1IF	T3IF
bit 15							bit 8

R/W-0, HS	U-0	U-0	U-0	R/W-0, HS	R/W-0, HS	R/W-0, HS	R/W-0, HS
T2IF	—	—	—	T1IF	OC1IF	IC1IF	INT0IF
bit 7							bit 0

<b>Legend:</b>	HS = Hardware Settable bit
R = Readable bit	W = Writable bit
-n = Value at POR	'1' = Bit is set
	U = Unimplemented bit, read as '0'
	'0' = Bit is cleared
	x = Bit is unknown

- bit 15      **NVMIF:** NVM Interrupt Flag Status bit  
1 = Interrupt request has occurred  
0 = Interrupt request has not occurred
- bit 14      **Unimplemented:** Read as '0'
- bit 13      **AD1IF:** A/D Conversion Complete Interrupt Flag Status bit  
1 = Interrupt request has occurred  
0 = Interrupt request has not occurred
- bit 12      **U1TXIF:** UART1 Transmitter Interrupt Flag Status bit  
1 = Interrupt request has occurred  
0 = Interrupt request has not occurred
- bit 11      **U1RXIF:** UART1 Receiver Interrupt Flag Status bit  
1 = Interrupt request has occurred  
0 = Interrupt request has not occurred
- bit 10      **SPI1IF:** SPI1 Event Interrupt Flag Status bit  
1 = Interrupt request has occurred  
0 = Interrupt request has not occurred
- bit 9        **SPF1IF:** SPI1 Fault Interrupt Flag Status bit  
1 = Interrupt request has occurred  
0 = Interrupt request has not occurred
- bit 8        **T3IF:** Timer3 Interrupt Flag Status bit  
1 = Interrupt request has occurred  
0 = Interrupt request has not occurred
- bit 7        **T2IF:** Timer2 Interrupt Flag Status bit  
1 = Interrupt request has occurred  
0 = Interrupt request has not occurred
- bit 6-4     **Unimplemented:** Read as '0'
- bit 3        **T1IF:** Timer1 Interrupt Flag Status bit  
1 = Interrupt request has occurred  
0 = Interrupt request has not occurred
- bit 2        **OC1IF:** Output Compare Channel 1 Interrupt Flag Status bit  
1 = Interrupt request has occurred  
0 = Interrupt request has not occurred
- bit 1        **IC1IF:** Input Capture Channel 1 Interrupt Flag Status bit  
1 = Interrupt request has occurred  
0 = Interrupt request has not occurred
- bit 0        **INT0IF:** External Interrupt 0 Flag Status bit  
1 = Interrupt request has occurred  
0 = Interrupt request has not occurred

# PIC24F16KA102 FAMILY

## REGISTER 8-6: IFS1: INTERRUPT FLAG STATUS REGISTER 1

R/W-0, HS	R/W-0, HS	R/W-0, HS	U-0	U-0	U-0	U-0	U-0
U2TXIF	U2RXIF	INT2IF	—	—	—	—	—
bit 15							bit 8

U-0	U-0	U-0	R/W-0, HS	R/W-0, HS	R/W-0, HS	R/W-0	R/W-0
—	—	—	INT1IF	CNIF	CMIF	MI2C1IF	SI2C1IF
bit 7							bit 0

<b>Legend:</b>	HS = Hardware Settable bit
R = Readable bit	W = Writable bit
-n = Value at POR	'1' = Bit is set
	U = Unimplemented bit, read as '0'
	'0' = Bit is cleared
	x = Bit is unknown

- bit 15      **U2TXIF:** UART2 Transmitter Interrupt Flag Status bit  
1 = Interrupt request has occurred  
0 = Interrupt request has not occurred
- bit 14      **U2RXIF:** UART2 Receiver Interrupt Flag Status bit  
1 = Interrupt request has occurred  
0 = Interrupt request has not occurred
- bit 13      **INT2IF:** External Interrupt 2 Flag Status bit  
1 = Interrupt request has occurred  
0 = Interrupt request has not occurred
- bit 12-5    **Unimplemented:** Read as '0'
- bit 4        **INT1IF:** External Interrupt 1 Flag Status bit  
1 = Interrupt request has occurred  
0 = Interrupt request has not occurred
- bit 3        **CNIF:** Input Change Notification Interrupt Flag Status bit  
1 = Interrupt request has occurred  
0 = Interrupt request has not occurred
- bit 2        **CMIF:** Comparator Interrupt Flag Status bit  
1 = Interrupt request has occurred  
0 = Interrupt request has not occurred
- bit 1        **MI2C1IF:** Master I2C1 Event Interrupt Flag Status bit  
1 = Interrupt request has occurred  
0 = Interrupt request has not occurred
- bit 0        **SI2C1IF:** Slave I2C1 Event Interrupt Flag Status bit  
1 = Interrupt request has occurred  
0 = Interrupt request has not occurred



# PIC24F16KA102 FAMILY

## REGISTER 8-7: IFS3: INTERRUPT FLAG STATUS REGISTER 3

U-0	R/W-0, HS	U-0	U-0	U-0	U-0	U-0	U-0
—	RTCIF	—	—	—	—	—	—
bit 15							bit 8

U-0	U-0	U-0	U-0	U-0	U-0	U-0	U-0
—	—	—	—	—	—	—	—
bit 7							bit 0

<b>Legend:</b>	HS = Hardware Settable bit
R = Readable bit	W = Writable bit
-n = Value at POR	'1' = Bit is set
	'0' = Bit is cleared
	x = Bit is unknown
	U = Unimplemented bit, read as '0'

- bit 15      **Unimplemented:** Read as '0'
- bit 14      **RTCIF:** Real-Time Clock and Calendar Interrupt Flag Status bit
  - 1 = Interrupt request has occurred
  - 0 = Interrupt request has not occurred
- bit 13-0    **Unimplemented:** Read as '0'

# PIC24F16KA102 FAMILY

## REGISTER 8-8: IFS4: INTERRUPT FLAG STATUS REGISTER 4

U-0	U-0	R/W-0, HS	U-0	U-0	U-0	U-0	R/W-0, HS
—	—	CTMUIF	—	—	—	—	HLVDIF
bit 15							bit 8

U-0	U-0	U-0	U-0	R/W-0, HS	R/W-0, HS	R/W-0, HS	U-0
—	—	—	—	CRCIF	U2ERIF	U1ERIF	—
bit 7							bit 0

<b>Legend:</b>	HS = Hardware Settable bit		
R = Readable bit	W = Writable bit	U = Unimplemented bit, read as '0'	
-n = Value at POR	'1' = Bit is set	'0' = Bit is cleared	x = Bit is unknown

- bit 15-14     **Unimplemented:** Read as '0'
- bit 13       **CTMUIF:** CTMU Interrupt Flag Status bit  
                   1 = Interrupt request has occurred  
                   0 = Interrupt request has not occurred
- bit 12-9     **Unimplemented:** Read as '0'
- bit 8         **HLVDIF:** High/Low-Voltage Detect Interrupt Flag Status bit  
                   1 = Interrupt request has occurred  
                   0 = Interrupt request has not occurred
- bit 7-4      **Unimplemented:** Read as '0'
- bit 3         **CRCIF:** CRC Generator Interrupt Flag Status bit  
                   1 = Interrupt request has occurred  
                   0 = Interrupt request has not occurred
- bit 2         **U2ERIF:** UART2 Error Interrupt Flag Status bit  
                   1 = Interrupt request has occurred  
                   0 = Interrupt request has not occurred
- bit 1         **U1ERIF:** UART1 Error Interrupt Flag Status bit  
                   1 = Interrupt request has occurred  
                   0 = Interrupt request has not occurred
- bit 0         **Unimplemented:** Read as '0'

# PIC24F16KA102 FAMILY

## REGISTER 8-9: IEC0: INTERRUPT ENABLE CONTROL REGISTER 0

R/W-0	U-0	R/W-0	R/W-0	R/W-0	R/W-0	R/W-0	R/W-0
NVMIE	—	AD1IE	U1TXIE	U1RXIE	SPI1IE	SPF1IE	T3IE
bit 15							bit 8

R/W-0	U-0	U-0	U-0	R/W-0	R/W-0	R/W-0	R/W-0
T2IE	—	—	—	T1IE	OC1IE	IC1IE	INT0IE
bit 7							bit 0

### Legend:

R = Readable bit                      W = Writable bit                      U = Unimplemented bit, read as '0'  
 -n = Value at POR                      '1' = Bit is set                      '0' = Bit is cleared                      x = Bit is unknown

- bit 15      **NVMIE:** NVM Interrupt Enable bit  
             1 = Interrupt request is enabled  
             0 = Interrupt request is not enabled
- bit 14      **Unimplemented:** Read as '0'
- bit 13      **AD1IE:** A/D Conversion Complete Interrupt Enable bit  
             1 = Interrupt request is enabled  
             0 = Interrupt request is not enabled
- bit 12      **U1TXIE:** UART1 Transmitter Interrupt Enable bit  
             1 = Interrupt request is enabled  
             0 = Interrupt request is not enabled
- bit 11      **U1RXIE:** UART1 Receiver Interrupt Enable bit  
             1 = Interrupt request is enabled  
             0 = Interrupt request is not enabled
- bit 10      **SPI1IE:** SPI1 Transfer Complete Interrupt Enable bit  
             1 = Interrupt request is enabled  
             0 = Interrupt request is not enabled
- bit 9        **SPF1IE:** SPI1 Fault Interrupt Enable bit  
             1 = Interrupt request is enabled  
             0 = Interrupt request is not enabled
- bit 8        **T3IE:** Timer3 Interrupt Enable bit  
             1 = Interrupt request is enabled  
             0 = Interrupt request is not enabled
- bit 7        **T2IE:** Timer2 Interrupt Enable bit  
             1 = Interrupt request is enabled  
             0 = Interrupt request not is enabled
- bit 6-4     **Unimplemented:** Read as '0'
- bit 3        **T1IE:** Timer1 Interrupt Enable bit  
             1 = Interrupt request is enabled  
             0 = Interrupt request is not enabled
- bit 2        **OC1IE:** Output Compare Channel 1 Interrupt Enable bit  
             1 = Interrupt request is enabled  
             0 = Interrupt request is not enabled
- bit 1        **IC1IE:** Input Capture Channel 1 Interrupt Enable bit  
             1 = Interrupt request is enabled  
             0 = Interrupt request is not enabled
- bit 0        **INT0IE:** External Interrupt 0 Enable bit  
             1 = Interrupt request is enabled  
             0 = Interrupt request is not enabled

# PIC24F16KA102 FAMILY

## REGISTER 8-10: IEC1: INTERRUPT ENABLE CONTROL REGISTER 1

R/W-0	R/W-0	R/W-0	U-0	U-0	U-0	U-0	U-0
U2TXIE	U2RXIE	INT2IE	—	—	—	—	—
bit 15							bit 8

U-0	U-0	U-0	R/W-0	R/W-0	R/W-0	R/W-0	R/W-0
—	—	—	INT1IE	CNIE	CMIE	MI2C1IE	SI2C1IE
bit 7							bit 0

### Legend:

R = Readable bit

W = Writable bit

U = Unimplemented bit, read as '0'

-n = Value at POR

'1' = Bit is set

'0' = Bit is cleared

x = Bit is unknown

- bit 15      **U2TXIE:** UART2 Transmitter Interrupt Enable bit  
             1 = Interrupt request is enabled  
             0 = Interrupt request is not enabled
- bit 14      **U2RXIE:** UART2 Receiver Interrupt Enable bit  
             1 = Interrupt request is enabled  
             0 = Interrupt request is not enabled
- bit 13      **INT2IE:** External Interrupt 2 Enable bit  
             1 = Interrupt request is enabled  
             0 = Interrupt request is not enabled
- bit 12-5    **Unimplemented:** Read as '0'
- bit 4        **INT1IE:** External Interrupt 1 Enable bit  
             1 = Interrupt request is enabled  
             0 = Interrupt request is not enabled
- bit 3        **CNIE:** Input Change Notification Interrupt Enable bit  
             1 = Interrupt request is enabled  
             0 = Interrupt request is not enabled
- bit 2        **CMIE:** Comparator Interrupt Enable bit  
             1 = Interrupt request is enabled  
             0 = Interrupt request is not enabled
- bit 1        **MI2C1IE:** Master I2C1 Event Interrupt Enable bit  
             1 = Interrupt request is enabled  
             0 = Interrupt request is not enabled
- bit 0        **SI2C1IE:** Slave I2C1 Event Interrupt Enable bit  
             1 = Interrupt request is enabled  
             0 = Interrupt request is not enabled

# PIC24F16KA102 FAMILY

## REGISTER 8-11: IEC3: INTERRUPT ENABLE CONTROL REGISTER 3

U-0	R/W-0	U-0	U-0	U-0	U-0	U-0	U-0
—	RTCIE	—	—	—	—	—	—
bit 15							bit 8

U-0	U-0	U-0	U-0	U-0	U-0	U-0	U-0
—	—	—	—	—	—	—	—
bit 7							bit 0

### Legend:

R = Readable bit

W = Writable bit

U = Unimplemented bit, read as '0'

-n = Value at POR

'1' = Bit is set

'0' = Bit is cleared

x = Bit is unknown

bit 15      **Unimplemented:** Read as '0'

bit 14      **RTCIE:** Real-Time Clock and Calendar Interrupt Enable bit

1 = Interrupt request is enabled

0 = Interrupt request is not enabled

bit 13-0    **Unimplemented:** Read as '0'

# PIC24F16KA102 FAMILY

## REGISTER 8-12: IEC4: INTERRUPT ENABLE CONTROL REGISTER 4

U-0	U-0	R/W-0	U-0	U-0	U-0	U-0	R/W-0
—	—	CTMUIE	—	—	—	—	HLVDIE
bit 15							bit 8

U-0	U-0	U-0	U-0	R/W-0	R/W-0	R/W-0	U-0
—	—	—	—	CRCIE	U2ERIE	U1ERIE	—
bit 7							bit 0

### Legend:

R = Readable bit

W = Writable bit

U = Unimplemented bit, read as '0'

-n = Value at POR

'1' = Bit is set

'0' = Bit is cleared

x = Bit is unknown

- bit 15-14     **Unimplemented:** Read as '0'
- bit 13       **CTMUIE:** CTMU Interrupt Enable bit  
               1 = Interrupt request is enabled  
               0 = Interrupt request is not enabled
- bit 12-9     **Unimplemented:** Read as '0'
- bit 8         **HLVDIE:** High/Low-Voltage Detect Interrupt Enable bit  
               1 = Interrupt request is enabled  
               0 = Interrupt request is not enabled
- bit 7-4      **Unimplemented:** Read as '0'
- bit 3         **CRCIE:** CRC Generator Interrupt Enable bit  
               1 = Interrupt request is enabled  
               0 = Interrupt request is not enabled
- bit 2         **U2ERIE:** UART2 Error Interrupt Enable bit  
               1 = Interrupt request is enabled  
               0 = Interrupt request is not enabled
- bit 1         **U1ERIE:** UART1 Error Interrupt Enable bit  
               1 = Interrupt request is enabled  
               0 = Interrupt request is not enabled
- bit 0         **Unimplemented:** Read as '0'

# PIC24F16KA102 FAMILY

## REGISTER 8-13: IPC0: INTERRUPT PRIORITY CONTROL REGISTER 0

U-0	R/W-1	R/W-0	R/W-0	U-0	R/W-1	R/W-0	R/W-0
—	T1IP2	T1IP1	T1IP0	—	OC1IP2	OC1IP1	OC1IP0
bit 15				bit 8			

U-0	R/W-1	R/W-0	R/W-0	U-0	R/W-1	R/W-0	R/W-0
—	IC1IP2	IC1IP1	IC1IP0	—	INT0IP2	INT0IP1	INT0IP0
bit 7				bit 0			

### Legend:

R = Readable bit

W = Writable bit

U = Unimplemented bit, read as '0'

-n = Value at POR

'1' = Bit is set

'0' = Bit is cleared

x = Bit is unknown

- bit 15      **Unimplemented:** Read as '0'
- bit 14-12    **T1IP<2:0>:** Timer1 Interrupt Priority bits  
 111 = Interrupt is Priority 7 (highest priority interrupt)  
 •  
 •  
 •  
 001 = Interrupt is Priority 1  
 000 = Interrupt source is disabled
- bit 11      **Unimplemented:** Read as '0'
- bit 10-8    **OC1IP<2:0>:** Output Compare Channel 1 Interrupt Priority bits  
 111 = Interrupt is Priority 7 (highest priority interrupt)  
 •  
 •  
 •  
 001 = Interrupt is Priority 1  
 000 = Interrupt source is disabled
- bit 7        **Unimplemented:** Read as '0'
- bit 6-4     **IC1IP<2:0>:** Input Capture Channel 1 Interrupt Priority bits  
 111 = Interrupt is Priority 7 (highest priority interrupt)  
 •  
 •  
 •  
 001 = Interrupt is Priority 1  
 000 = Interrupt source is disabled
- bit 3        **Unimplemented:** Read as '0'
- bit 2-0     **INT0IP<2:0>:** External Interrupt 0 Priority bits  
 111 = Interrupt is Priority 7 (highest priority interrupt)  
 •  
 •  
 •  
 001 = Interrupt is Priority 1  
 000 = Interrupt source is disabled

# PIC24F16KA102 FAMILY

## REGISTER 8-14: IPC1: INTERRUPT PRIORITY CONTROL REGISTER 1

U-0	R/W-1	R/W-0	R/W-0	U-0	U-0	U-0	U-0
—	T2IP2	T2IP1	T2IP0	—	—	—	—
bit 15							bit 8

U-0	U-0	U-0	U-0	U-0	U-0	U-0	U-0
—	—	—	—	—	—	—	—
bit 7							bit 0

### Legend:

R = Readable bit                      W = Writable bit                      U = Unimplemented bit, read as '0'  
 -n = Value at POR                      '1' = Bit is set                      '0' = Bit is cleared                      x = Bit is unknown

- bit 15                      **Unimplemented:** Read as '0'
- bit 14-12                **T2IP<2:0>:** Timer2 Interrupt Priority bits
  - 111 = Interrupt is Priority 7 (highest priority interrupt)
  - 
  - 
  - 
  - 001 = Interrupt is Priority 1
  - 000 = Interrupt source is disabled
- bit 11-0                **Unimplemented:** Read as '0'



# PIC24F16KA102 FAMILY

## REGISTER 8-15: IPC2: INTERRUPT PRIORITY CONTROL REGISTER 2

U-0	R/W-1	R/W-0	R/W-0	U-0	R/W-1	R/W-0	R/W-0
—	U1RXIP2	U1RXIP1	U1RXIP0	—	SPI1IP2	SPI1IP1	SPI1IP0
bit 15						bit 8	

U-0	R/W-1	R/W-0	R/W-0	U-0	R/W-1	R/W-0	R/W-0
—	SPF1IP2	SPF1IP1	SPF1IP0	—	T3IP2	T3IP1	T3IP0
bit 7						bit 0	

### Legend:

R = Readable bit

W = Writable bit

U = Unimplemented bit, read as '0'

-n = Value at POR

'1' = Bit is set

'0' = Bit is cleared

x = Bit is unknown

- bit 15      **Unimplemented:** Read as '0'
- bit 14-12    **U1RXIP<2:0>:** UART1 Receiver Interrupt Priority bits  
 111 = Interrupt is Priority 7 (highest priority interrupt)  
 •  
 •  
 •  
 001 = Interrupt is Priority 1  
 000 = Interrupt source is disabled
- bit 11      **Unimplemented:** Read as '0'
- bit 10-8    **SPI1IP<2:0>:** SPI1 Event Interrupt Priority bits  
 111 = Interrupt is Priority 7 (highest priority interrupt)  
 •  
 •  
 •  
 001 = Interrupt is Priority 1  
 000 = Interrupt source is disabled
- bit 7       **Unimplemented:** Read as '0'
- bit 6-4    **SPF1IP<2:0>:** SPI1 Fault Interrupt Priority bits  
 111 = Interrupt is Priority 7 (highest priority interrupt)  
 •  
 •  
 •  
 001 = Interrupt is Priority 1  
 000 = Interrupt source is disabled
- bit 3       **Unimplemented:** Read as '0'
- bit 2-0    **T3IP<2:0>:** Timer3 Interrupt Priority bits  
 111 = Interrupt is Priority 7 (highest priority interrupt)  
 •  
 •  
 •  
 001 = Interrupt is Priority 1  
 000 = Interrupt source is disabled

# PIC24F16KA102 FAMILY

## REGISTER 8-16: IPC3: INTERRUPT PRIORITY CONTROL REGISTER 3

U-0	R/W-1	R/W-0	R/W-0	U-0	U-0	U-0	U-0
—	NVMIP2	NVMIP1	NVMIP0	—	—	—	—
bit 15							bit 8

U-0	R/W-1	R/W-0	R/W-0	U-0	R/W-1	R/W-0	R/W-0
—	AD1IP2	AD1IP1	AD1IP0	—	U1TXIP2	U1TXIP1	U1TXIP0
bit 7							bit 0

### Legend:

R = Readable bit

W = Writable bit

U = Unimplemented bit, read as '0'

-n = Value at POR

'1' = Bit is set

'0' = Bit is cleared

x = Bit is unknown

bit 15 **Unimplemented:** Read as '0'

bit 14-12 **NVMIP<2:0>:** NVM Interrupt Priority bits  
111 = Interrupt is Priority 7 (highest priority interrupt)

- 
- 
- 

001 = Interrupt is Priority 1  
000 = Interrupt source is disabled

bit 11-7 **Unimplemented:** Read as '0'

bit 6-4 **AD1IP<2:0>:** A/D Conversion Complete Interrupt Priority bits  
111 = Interrupt is Priority 7 (highest priority interrupt)

- 
- 
- 

001 = Interrupt is Priority 1  
000 = Interrupt source is disabled

bit 3 **Unimplemented:** Read as '0'

bit 2-0 **U1TXIP<2:0>:** UART1 Transmitter Interrupt Priority bits  
111 = Interrupt is Priority 7 (highest priority interrupt)

- 
- 
- 

001 = Interrupt is Priority 1  
000 = Interrupt source is disabled

# PIC24F16KA102 FAMILY

## REGISTER 8-17: IPC4: INTERRUPT PRIORITY CONTROL REGISTER 4

U-0	R/W-1	R/W-0	R/W-0	U-0	R/W-1	R/W-0	R/W-0
—	CNIP2	CNIP1	CNIP0	—	CMIP2	CMIP1	CMIP0
bit 15						bit 8	

U-0	R/W-1	R/W-0	R/W-0	U-0	R/W-1	R/W-0	R/W-0
—	MI2C1P2	MI2C1P1	MI2C1P0	—	SI2C1P2	SI2C1P1	SI2C1P0
bit 7						bit 0	

### Legend:

R = Readable bit

W = Writable bit

U = Unimplemented bit, read as '0'

-n = Value at POR

'1' = Bit is set

'0' = Bit is cleared

x = Bit is unknown

- bit 15      **Unimplemented:** Read as '0'
- bit 14-12    **CNIP<2:0>:** Input Change Notification Interrupt Priority bits  
                  111 = Interrupt is Priority 7 (highest priority interrupt)  
                  •  
                  •  
                  •  
                  001 = Interrupt is Priority 1  
                  000 = Interrupt source is disabled
- bit 11      **Unimplemented:** Read as '0'
- bit 10-8    **CMIP<2:0>:** Comparator Interrupt Priority bits  
                  111 = Interrupt is Priority 7 (highest priority interrupt)  
                  •  
                  •  
                  •  
                  001 = Interrupt is Priority 1  
                  000 = Interrupt source is disabled
- bit 7       **Unimplemented:** Read as '0'
- bit 6-4    **MI2C1P<2:0>:** Master I2C1 Event Interrupt Priority bits  
                  111 = Interrupt is Priority 7 (highest priority interrupt)  
                  •  
                  •  
                  •  
                  001 = Interrupt is Priority 1  
                  000 = Interrupt source is disabled
- bit 3       **Unimplemented:** Read as '0'
- bit 2-0    **SI2C1P<2:0>:** Slave I2C1 Event Interrupt Priority bits  
                  111 = Interrupt is Priority 7 (highest priority interrupt)  
                  •  
                  •  
                  •  
                  001 = Interrupt is Priority 1  
                  000 = Interrupt source is disabled

# PIC24F16KA102 FAMILY

## REGISTER 8-18: IPC5: INTERRUPT PRIORITY CONTROL REGISTER 5

U-0	U-0	U-0	U-0	U-0	U-0	U-0	U-0
—	—	—	—	—	—	—	—
bit 15							bit 8

U-0	U-0	U-0	U-0	U-0	R/W-1	R/W-0	R/W-0
—	—	—	—	—	INT1IP2	INT1IP1	INT1IP0
bit 7					bit 0		

### Legend:

R = Readable bit                      W = Writable bit                      U = Unimplemented bit, read as '0'  
 -n = Value at POR                      '1' = Bit is set                      '0' = Bit is cleared                      x = Bit is unknown

bit 15-3                      **Unimplemented:** Read as '0'  
 bit 2-0                      **INT1IP<2:0>:** External Interrupt 1 Priority bits  
                                     111 = Interrupt is Priority 7 (highest priority interrupt)  
                                     •  
                                     •  
                                     •  
                                     001 = Interrupt is Priority 1  
                                     000 = Interrupt source is disabled

# PIC24F16KA102 FAMILY

## REGISTER 8-19: IPC7: INTERRUPT PRIORITY CONTROL REGISTER 7

U-0	R/W-1	R/W-0	R/W-0	U-0	R/W-1	R/W-0	R/W-0
—	U2TXIP2	U2TXIP1	U2TXIP0	—	U2RXIP2	U2RXIP1	U2RXIP0
bit 15				bit 8			

U-0	R/W-1	R/W-0	R/W-0	U-0	U-0	U-0	U-0
—	INT2IP2	INT2IP1	INT2IP0	—	—	—	—
bit 7				bit 0			

### Legend:

R = Readable bit                      W = Writable bit                      U = Unimplemented bit, read as '0'  
 -n = Value at POR                      '1' = Bit is set                      '0' = Bit is cleared                      x = Bit is unknown

- bit 15                      **Unimplemented:** Read as '0'
- bit 14-12                **U2TXIP<2:0>:** UART2 Transmitter Interrupt Priority bits
  - 111 = Interrupt is Priority 7 (highest priority interrupt)
  - 
  - 
  - 
  - 001 = Interrupt is Priority 1
  - 000 = Interrupt source is disabled
- bit 11                    **Unimplemented:** Read as '0'
- bit 10-8                **U2RXIP<2:0>:** UART2 Receiver Interrupt Priority bits
  - 111 = Interrupt is Priority 7 (highest priority interrupt)
  - 
  - 
  - 
  - 001 = Interrupt is Priority 1
  - 000 = Interrupt source is disabled
- bit 7                     **Unimplemented:** Read as '0'
- bit 6-4                 **INT2IP<2:0>:** External Interrupt 2 Priority bits
  - 111 = Interrupt is Priority 7 (highest priority interrupt)
  - 
  - 
  - 
  - 001 = Interrupt is Priority 1
  - 000 = Interrupt source is disabled
- bit 3-0                 **Unimplemented:** Read as '0'

# PIC24F16KA102 FAMILY

## REGISTER 8-20: IPC15: INTERRUPT PRIORITY CONTROL REGISTER 15

U-0	U-0	U-0	U-0	U-0	R/W-1	R/W-0	R/W-0
—	—	—	—	—	RTCIP2	RTCIP1	RTCIP0
bit 15						bit 8	

U-0	U-0	U-0	U-0	U-0	U-0	U-0	U-0
—	—	—	—	—	—	—	—
bit 7						bit 0	

### Legend:

R = Readable bit	W = Writable bit	U = Unimplemented bit, read as '0'
-n = Value at POR	'1' = Bit is set	'0' = Bit is cleared      x = Bit is unknown

bit 15-11      **Unimplemented:** Read as '0'

bit 10-8      **RTCIP<2:0>:** Real-Time Clock and Calendar Interrupt Priority bits  
                  111 = Interrupt is Priority 7 (highest priority interrupt)  
                  •  
                  •  
                  •  
                  001 = Interrupt is Priority 1  
                  000 = Interrupt source is disabled

bit 7-0      **Unimplemented:** Read as '0'

# PIC24F16KA102 FAMILY

## REGISTER 8-21: IPC16: INTERRUPT PRIORITY CONTROL REGISTER 16

U-0	R/W-1	R/W-0	R/W-0	U-0	R/W-1	R/W-0	R/W-0
—	CRCIP2	CRCIP1	CRCIP0	—	U2ERIP2	U2ERIP1	U2ERIP0
bit 15							bit 8

U-0	R/W-1	R/W-0	R/W-0	U-0	U-0	U-0	U-0
—	U1ERIP2	U1ERIP1	U1ERIP0	—	—	—	—
bit 7							bit 0

### Legend:

R = Readable bit

W = Writable bit

U = Unimplemented bit, read as '0'

-n = Value at POR

'1' = Bit is set

'0' = Bit is cleared

x = Bit is unknown

- bit 15      **Unimplemented:** Read as '0'
- bit 14-12    **CRCIP<2:0>:** CRC Generator Error Interrupt Priority bits  
 111 = Interrupt is Priority 7 (highest priority interrupt)  
 •  
 •  
 •  
 001 = Interrupt is Priority 1  
 000 = Interrupt source is disabled
- bit 11      **Unimplemented:** Read as '0'
- bit 10-8    **U2ERIP<2:0>:** UART2 Error Interrupt Priority bits  
 111 = Interrupt is Priority 7 (highest priority interrupt)  
 •  
 •  
 •  
 001 = Interrupt is Priority 1  
 000 = Interrupt source is disabled
- bit 7        **Unimplemented:** Read as '0'
- bit 6-4     **U1ERIP<2:0>:** UART1 Error Interrupt Priority bits  
 111 = Interrupt is Priority 7 (highest priority interrupt)  
 •  
 •  
 •  
 001 = Interrupt is Priority 1  
 000 = Interrupt source is disabled
- bit 3-0     **Unimplemented:** Read as '0'

# PIC24F16KA102 FAMILY

## REGISTER 8-22: IPC18: INTERRUPT PRIORITY CONTROL REGISTER 18

U-0	U-0	U-0	U-0	U-0	U-0	U-0	U-0
—	—	—	—	—	—	—	—
bit 15							bit 8

U-0	U-0	U-0	U-0	U-0	R/W-1	R/W-0	R/W-0
—	—	—	—	—	HLVDIP2	HLVDIP1	HLVDIP0
bit 7							bit 0

### Legend:

R = Readable bit                      W = Writable bit                      U = Unimplemented bit, read as '0'  
-n = Value at POR                      '1' = Bit is set                      '0' = Bit is cleared                      x = Bit is unknown

bit 15-3            **Unimplemented:** Read as '0'  
bit 2-0            **HLVDIP<2:0>:** High/Low-Voltage Detect Interrupt Priority bits  
                    111 = Interrupt is Priority 7 (highest priority interrupt)  
                    •  
                    •  
                    •  
                    001 = Interrupt is Priority 1  
                    000 = Interrupt source is disabled

## REGISTER 8-23: IPC19: INTERRUPT PRIORITY CONTROL REGISTER 19

U-0	U-0	U-0	U-0	U-0	U-0	U-0	U-0
—	—	—	—	—	—	—	—
bit 15							bit 8

U-0	R/W-1	R/W-0	R/W-0	U-0	U-0	U-0	U-0
—	CTMUIP2	CTMUIP1	CTMUIP0	—	—	—	—
bit 7							bit 0

### Legend:

R = Readable bit                      W = Writable bit                      U = Unimplemented bit, read as '0'  
-n = Value at POR                      '1' = Bit is set                      '0' = Bit is cleared                      x = Bit is unknown

bit 15-7            **Unimplemented:** Read as '0'  
bit 6-4            **CTMUIP<2:0>:** CTMU Interrupt Priority bits  
                    111 = Interrupt is Priority 7 (highest priority interrupt)  
                    •  
                    •  
                    •  
                    001 = Interrupt is Priority 1  
                    000 = Interrupt source is disabled  
bit 3-0            **Unimplemented:** Read as '0'



# PIC24F16KA102 FAMILY

## REGISTER 8-24: INTTREG: INTERRUPT CONTROL AND STATUS REGISTER

R-0	U-0	R/W-0	U-0	R-0	R-0	R-0	R-0
CPUIRQ	—	VHOLD	—	ILR3	ILR2	ILR1	ILR0
bit 15				bit 8			

U-0	R-0	R-0	R-0	R-0	R-0	R-0	R-0
—	VECNUM6	VECNUM5	VECNUM4	VECNUM3	VECNUM2	VECNUM1	VECNUM0
bit 7				bit 0			

### Legend:

R = Readable bit

W = Writable bit

U = Unimplemented bit, read as '0'

-n = Value at POR

'1' = Bit is set

'0' = Bit is cleared

x = Bit is unknown

- bit 15      **CPUIRQ:** Interrupt Request from Interrupt Controller CPU bit  
 1 = An interrupt request has occurred but has not yet been Acknowledged by the CPU (this will happen when the CPU priority is higher than the interrupt priority)  
 0 = No interrupt request is left unacknowledged
- bit 14      **Unimplemented:** Read as '0'
- bit 13      **VHOLD:** Allows Vector Number Capture and Changes what Interrupt is Stored in VECNUM bit  
 1 = VECNUM will contain the value of the highest priority pending interrupt, instead of the current interrupt  
 0 = VECNUM will contain the value of the last Acknowledged interrupt (last interrupt that has occurred with higher priority than the CPU, even if other interrupts are pending)
- bit 12      **Unimplemented:** Read as '0'
- bit 11-8    **ILR<3:0>:** New CPU Interrupt Priority Level bits  
 1111 = CPU Interrupt Priority Level is 15  
 •  
 •  
 •  
 0001 = CPU Interrupt Priority Level is 1  
 0000 = CPU Interrupt Priority Level is 0
- bit 7        **Unimplemented:** Read as '0'
- bit 6-0     **VECNUM<6:0>:** Vector Number of Pending Interrupt bits  
 0111111 = Interrupt Vector pending is Number 135  
 •  
 •  
 •  
 0000001 = Interrupt Vector pending is Number 9  
 0000000 = Interrupt Vector pending is Number 8

# PIC24F16KA102 FAMILY

---

## 8.4 Interrupt Setup Procedures

### 8.4.1 INITIALIZATION

To configure an interrupt source:

1. Set the NSTDIS Control bit (INTCON1<15>) if nested interrupts are not desired.
2. Select the user-assigned priority level for the interrupt source by writing the control bits in the appropriate IPCx register. The priority level will depend on the specific application and type of interrupt source. If multiple priority levels are not desired, the IPCx register control bits, for all enabled interrupt sources, may be programmed to the same non-zero value.

**Note:** At a device Reset, the IPCx registers are initialized, such that all user interrupt sources are assigned to Priority Level 4.

3. Clear the interrupt flag status bit associated with the peripheral in the associated IFSx register.
4. Enable the interrupt source by setting the interrupt enable control bit associated with the source in the appropriate IECx register.

### 8.4.2 INTERRUPT SERVICE ROUTINE

The method that is used to declare an ISR and initialize the IVT with the correct vector address depends on the programming language (i.e., C or assembler) and the language development toolsuite that is used to develop the application. In general, the user must clear the interrupt flag in the appropriate IFSx register for the source of the interrupt that the ISR handles. Otherwise, the ISR will be re-entered immediately after exiting the routine. If the ISR is coded in assembly language, it must be terminated using a `RETFIE` instruction to unstack the saved PC value, SRL value and old CPU priority level.

### 8.4.3 TRAP SERVICE ROUTINE (TSR)

A Trap Service Routine (TSR) is coded like an ISR, except that the appropriate trap status flag in the INTCON1 register must be cleared to avoid re-entry into the TSR.

### 8.4.4 INTERRUPT DISABLE

All user interrupts can be disabled using the following procedure:

1. Push the current SR value onto the software stack using the `PUSH` instruction.
2. Force the CPU to Priority Level 7 by inclusive ORing the value OEH with SRL.

To enable user interrupts, the `POP` instruction may be used to restore the previous SR value.

Only user interrupts with a priority level of 7 or less can be disabled. Trap sources (Levels 8-15) cannot be disabled.

The `DISI` instruction provides a convenient way to disable interrupts of Priority Levels 1-6 for a fixed period. Level 7 interrupt sources are not disabled by the `DISI` instruction.

# PIC24F16KA102 FAMILY

## 9.0 OSCILLATOR CONFIGURATION

**Note:** This data sheet summarizes the features of this group of PIC24F devices. It is not intended to be a comprehensive reference source. For more information on Oscillator Configuration, refer to the "PIC24F Family Reference Manual", Section 38. "Oscillator with 500 kHz Low-Power FRC" (DS39726).

The oscillator system for the PIC24F16KA102 family of devices has the following features:

- A total of five external and internal oscillator options as clock sources, providing 11 different clock modes.
- On-chip 4x Phase Locked Loop (PLL) to boost internal operating frequency on select internal and external oscillator sources.

- Software-controllable switching between various clock sources.
- Software-controllable postscaler for selective clocking of CPU for system power savings.
- System frequency range declaration bits for EC mode. When using an external clock source, the current consumption is reduced by setting the declaration bits to the expected frequency range.
- A Fail-Safe Clock Monitor (FSCM) that detects clock failure and permits safe application recovery or shutdown.

Figure 9-1 provides a simplified diagram of the oscillator system.

FIGURE 9-1: PIC24F16KA102 FAMILY CLOCK DIAGRAM

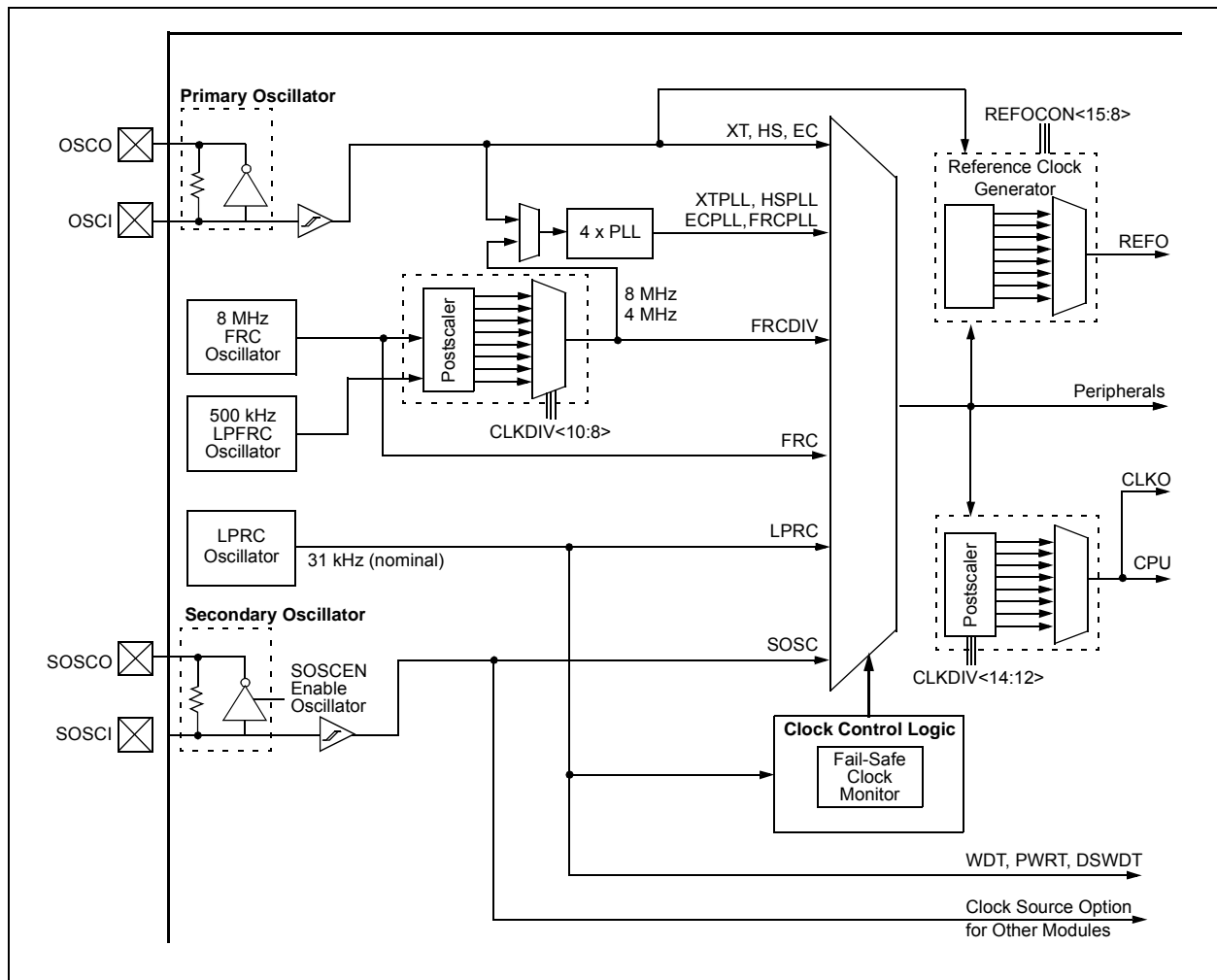

# PIC24F16KA102 FAMILY

## 9.1 CPU Clocking Scheme

The system clock source can be provided by one of four sources:

- Primary Oscillator (POSC) on the OSC1 and OSCO pins
- Secondary Oscillator (SOSC) on the SOSCI and SOSCO pins

The PIC24F16KA102 family devices consist of two types of secondary oscillator:

- High-Power Secondary Oscillator
- Low-Power Secondary Oscillator

These can be selected by using the SOSSEL (FOSC<5>) bit.

- Fast Internal RC (FRC) Oscillator
  - 8 MHz FRC Oscillator
  - 500 kHz Lower Power FRC Oscillator
- Low-Power Internal RC (LPRC) Oscillator

The primary oscillator and 8 MHz FRC sources have the option of using the internal 4x PLL. The frequency of the FRC clock source can optionally be reduced by the programmable clock divider. The selected clock source generates the processor and peripheral clock sources.

The processor clock source is divided by two to produce the internal instruction cycle clock, F<sub>cy</sub>. In this document, the instruction cycle clock is also denoted by Fosc/2. The internal instruction cycle clock, Fosc/2, can be provided on the OSCO I/O pin for some operating modes of the primary oscillator.

## 9.2 Initial Configuration on POR

The oscillator source (and operating mode) that is used at a device Power-on Reset (POR) event is selected using Configuration bit settings. The Oscillator Configuration bit settings are located in the Configuration registers in the program memory (refer to [Section 26.1 “Configuration Bits”](#) for further details). The Primary Oscillator Configuration bits, POSCMD<1:0> (FOSC<1:0>), and the Initial Oscillator Select Configuration bits, FNOSEC<2:0> (FOSCSEL<2:0>), select the oscillator source that is used at a POR. The FRC Primary Oscillator with Postscaler (FRCDIV) is the default (unprogrammed) selection. The secondary oscillator, or one of the internal oscillators, may be chosen by programming these bit locations. The EC mode frequency range Configuration bits, POSCFREQ<1:0> (FOSC<4:3>), optimize power consumption when running in EC mode. The default configuration is “frequency range is greater than 8 MHz”.

The Configuration bits allow users to choose between the various clock modes, shown in [Table 9-1](#).

### 9.2.1 CLOCK SWITCHING MODE CONFIGURATION BITS

The FCKSM Configuration bits (FOSC<7:6>) are used jointly to configure device clock switching and the FSCM. Clock switching is enabled only when FCKSM1 is programmed ('0'). The FSCM is enabled only when FCKSM<1:0> are both programmed ('00').

**TABLE 9-1: CONFIGURATION BIT VALUES FOR CLOCK SELECTION**

Oscillator Mode	Oscillator Source	POSCMD<1:0>	FNOSEC<2:0>	Note
8 MHz FRC Oscillator with Postscaler (FRCDIV)	Internal	11	111	<b>1, 2</b>
500 MHz FRC Oscillator with Postscaler (LPFRCDIV)	Internal	11	110	<b>1</b>
Low-Power RC Oscillator (LPRC)	Internal	11	101	<b>1</b>
Secondary (Timer1) Oscillator (SOSC)	Secondary	00	100	<b>1</b>
Primary Oscillator (HS) with PLL Module (HSPLL)	Primary	10	011	
Primary Oscillator (EC) with PLL Module (ECPLL)	Primary	00	011	
Primary Oscillator (HS)	Primary	10	010	
Primary Oscillator (XT)	Primary	01	010	
Primary Oscillator (EC)	Primary	00	010	
8 MHz FRC Oscillator with PLL Module (FRCPLL)	Internal	11	001	<b>1</b>
8 MHz FRC Oscillator (FRC)	Internal	11	000	<b>1</b>

**Note 1:** OSCO pin function is determined by the OSCIOFNC Configuration bit.

**2:** This is the default oscillator mode for an unprogrammed (erased) device.

# PIC24F16KA102 FAMILY

## 9.3 Control Registers

The operation of the oscillator is controlled by three Special Function Registers (SFRs):

- OSCCON
- CLKDIV
- OSCTUN

The OSCCON register (Register 9-1) is the main control register for the oscillator. It controls clock source switching and allows the monitoring of clock sources.

The Clock Divider register (Register 9-2) controls the features associated with Doze mode, as well as the postscaler for the FRC oscillator.

The FRC Oscillator Tune register (Register 9-3) allows the user to fine tune the FRC oscillator over a range of approximately  $\pm 5.25\%$ . Each bit increment or decrement changes the factory calibrated frequency of the FRC oscillator by a fixed amount.

### REGISTER 9-1: OSCCON: OSCILLATOR CONTROL REGISTER

U-0	R-0, HSC	R-0, HSC	R-0, HSC	U-0	R/W-x <sup>(1)</sup>	R/W-x <sup>(1)</sup>	R/W-x <sup>(1)</sup>
—	COSC2	COSC1	COSC0	—	NOSC2	NOSC1	NOSC0
bit 15				bit 8			

R/SO-0, HSC	U-0	R-0, HSC <sup>(2)</sup>	U-0	R/CO-0, HS	U-0	R/W-0	R/W-0
CLKLOCK	—	LOCK	—	CF	—	SOSCEN	OSWEN
bit 7				bit 0			

<b>Legend:</b>	CO = Clearable Only bit
SO = Settable Only bit	HS = Hardware Settable bit    HSC = Hardware Settable/Clearable bit
R = Readable bit	W = Writable bit    U = Unimplemented bit, read as '0'
-n = Value at POR	'1' = Bit is set    '0' = Bit is cleared    x = Bit is unknown

bit 15    **Unimplemented:** Read as '0'

bit 14-12    **COSC<2:0>:** Current Oscillator Selection bits

- 111 = 8 MHz Fast RC Oscillator with Postscaler (FRCDIV)
- 110 = 500 kHz Low-Power Fast RC Oscillator (FRC) with Postscaler (LPFRCDIV)
- 101 = Low-Power RC Oscillator (LPRC)
- 100 = Secondary Oscillator (SOSC)
- 011 = Primary Oscillator with PLL module (XTPLL, HSPLL, ECPLL)
- 010 = Primary Oscillator (XT, HS, EC)
- 001 = 8 MHz FRC Oscillator with Postscaler and PLL module (FRCPLL)
- 000 = 8 MHz FRC Oscillator (FRC)

bit 11    **Unimplemented:** Read as '0'

bit 10-8    **NOSC<2:0>:** New Oscillator Selection bits<sup>(1)</sup>

- 111 = 8 MHz Fast RC Oscillator with Postscaler (FRCDIV)
- 110 = 500 kHz Low-Power Fast RC Oscillator (FRC) with Postscaler (LPFRCDIV)
- 101 = Low-Power RC Oscillator (LPRC)
- 100 = Secondary Oscillator (SOSC)
- 011 = Primary Oscillator with PLL module (XTPLL, HSPLL, ECPLL)
- 010 = Primary Oscillator (XT, HS, EC)
- 001 = 8 MHz FRC Oscillator with Postscaler and PLL module (FRCPLL)
- 000 = 8 MHz FRC Oscillator (FRC)

**Note 1:** Reset values for these bits are determined by the FNOSC Configuration bits.

**2:** Also resets to '0' during any valid clock switch or whenever a non-PLL Clock mode is selected.

# PIC24F16KA102 FAMILY

---

## REGISTER 9-1: OSCCON: OSCILLATOR CONTROL REGISTER (CONTINUED)

- bit 7      **CLKLOCK:** Clock Selection Lock Enabled bit  
            If FSCM is enabled (FCKSM1 = 1):  
            1 = Clock and PLL selections are locked  
            0 = Clock and PLL selections are not locked and may be modified by setting the OSWEN bit  
            If FSCM is disabled (FCKSM1 = 0):  
            Clock and PLL selections are never locked and may be modified by setting the OSWEN bit.
- bit 6      **Unimplemented:** Read as '0'
- bit 5      **LOCK:** PLL Lock Status bit<sup>(2)</sup>  
            1 = PLL module is in lock or PLL module start-up timer is satisfied  
            0 = PLL module is out of lock, PLL start-up timer is running or PLL is disabled
- bit 4      **Unimplemented:** Read as '0'
- bit 3      **CF:** Clock Fail Detect bit  
            1 = FSCM has detected a clock failure  
            0 = No clock failure has been detected
- bit 2      **Unimplemented:** Read as '0'
- bit 1      **SOSCEN:** 32 kHz Secondary Oscillator (SOSC) Enable bit  
            1 = Enable secondary oscillator  
            0 = Disable secondary oscillator
- bit 0      **OSWEN:** Oscillator Switch Enable bit  
            1 = Initiate an oscillator switch to clock source specified by NOSC<2:0> bits  
            0 = Oscillator switch is complete

**Note 1:** Reset values for these bits are determined by the FNOSC Configuration bits.

**2:** Also resets to '0' during any valid clock switch or whenever a non-PLL Clock mode is selected.

# PIC24F16KA102 FAMILY

## REGISTER 9-2: CLKDIV: CLOCK DIVIDER REGISTER

R/W-0	R/W-0	R/W-1	R/W-1	R/W-0	R/W-0	R/W-0	R/W-1
ROI	DOZE2	DOZE1	DOZE0	DOZEN <sup>(1)</sup>	RCDIV2	RCDIV1	RCDIV0
bit 15						bit 8	

U-0	U-0	U-0	U-0	U-0	U-0	U-0	U-0
—	—	—	—	—	—	—	—
bit 7						bit 0	

### Legend:

R = Readable bit                      W = Writable bit                      U = Unimplemented bit, read as '0'  
 -n = Value at POR                      '1' = Bit is set                      '0' = Bit is cleared                      x = Bit is unknown

bit 15      **ROI:** Recover on Interrupt bit  
 1 = Interrupts clear the DOZEN bit and reset the CPU and peripheral clock ratio to 1:1  
 0 = Interrupts have no effect on the DOZEN bit

bit 14-12    **DOZE<2:0>:** CPU and Peripheral Clock Ratio Select bits  
 111 = 1:128  
 110 = 1:64  
 101 = 1:32  
 100 = 1:16  
 011 = 1:8  
 010 = 1:4  
 001 = 1:2  
 000 = 1:1

bit 11      **DOZEN:** DOZE Enable bit<sup>(1)</sup>  
 1 = DOZE<2:0> bits specify the CPU and peripheral clock ratio  
 0 = CPU and peripheral clock ratio are set to 1:1

bit 10-8    **RCDIV<2:0>:** FRC Postscaler Select bits  
When OSCCON (COSC<2:0>) = 111:  
 111 = 31.25 kHz (divide by 256)  
 110 = 125 kHz (divide by 64)  
 101 = 250 kHz (divide by 32)  
 100 = 500 kHz (divide by 16)  
 011 = 1 MHz (divide by 8)  
 010 = 2 MHz (divide by 4)  
 001 = 4 MHz (divide by 2) (default)  
 000 = 8 MHz (divide by 1)

When OSCCON (COSC<2:0>) = 110:  
 111 = 1.95 kHz (divide by 256)  
 110 = 7.81 kHz (divide by 64)  
 101 = 15.62 kHz (divide by 32)  
 100 = 31.25 kHz (divide by 16)  
 011 = 62.5 kHz (divide by 8)  
 010 = 125 kHz (divide by 4)  
 001 = 250 kHz (divide by 2) (default)  
 000 = 500 kHz (divide by 1)

bit 7-0      **Unimplemented:** Read as '0'

**Note 1:** This bit is automatically cleared when the ROI bit is set and an interrupt occurs.

# PIC24F16KA102 FAMILY

## REGISTER 9-3: OSCTUN: FRC OSCILLATOR TUNE REGISTER

U-0	U-0	U-0	U-0	U-0	U-0	U-0	U-0
—	—	—	—	—	—	—	—
bit 15							bit 8

U-0	U-0	R/W-0	R/W-0	R/W-0	R/W-0	R/W-0	R/W-0
—	—	TUN5 <sup>(1)</sup>	TUN4 <sup>(1)</sup>	TUN3 <sup>(1)</sup>	TUN2 <sup>(1)</sup>	TUN1 <sup>(1)</sup>	TUN0 <sup>(1)</sup>
bit 7							bit 0

### Legend:

R = Readable bit

W = Writable bit

U = Unimplemented bit, read as '0'

-n = Value at POR

'1' = Bit is set

'0' = Bit is cleared

x = Bit is unknown

bit 15-6

**Unimplemented:** Read as '0'

bit 5-0

**TUN<5:0>:** FRC Oscillator Tuning bits<sup>(1)</sup>

011111 = Maximum frequency deviation

011110

.

.

.

000001

000000 = Center frequency, oscillator is running at factory calibrated frequency

111111

.

.

.

100001

100000 = Minimum frequency deviation

**Note 1:** Increments or decrements of TUN<5:0> may not change the FRC frequency in equal steps over the FRC tuning range and may not be monotonic.



## 9.4 Clock Switching Operation

With few limitations, applications are free to switch between any of the four clock sources (POSC, SOSC, FRC and LPRC) under software control and at any time. To limit the possible side effects that could result from this flexibility, PIC24F devices have a safeguard lock built into the switching process.

**Note:** The Primary Oscillator mode has three different submodes (XT, HS and EC), which are determined by the POSCMDx Configuration bits. While an application can switch to and from Primary Oscillator mode in software, it cannot switch between the different primary submodes without reprogramming the device.

### 9.4.1 ENABLING CLOCK SWITCHING

To enable clock switching, the FCKSM1 Configuration bit in the FOSC Configuration register must be programmed to '0'. (Refer to [Section 26.1 "Configuration Bits"](#) for further details.) If the FCKSM1 Configuration bit is unprogrammed ('1'), the clock switching function and FSCM function are disabled; this is the default setting.

The NOSCx control bits (OSCCON<10:8>) do not control the clock selection when clock switching is disabled. However, the COSCx bits (OSCCON<14:12>) will reflect the clock source selected by the FNOSCx Configuration bits.

The OSWEN control bit (OSCCON<0>) has no effect when clock switching is disabled; it is held at '0' at all times.

### 9.4.2 OSCILLATOR SWITCHING SEQUENCE

At a minimum, performing a clock switch requires this basic sequence:

1. If desired, read the COSCx bits (OSCCON<14:12>), to determine the current oscillator source.
2. Perform the unlock sequence to allow a write to the OSCCON register high byte.
3. Write the appropriate value to the NOSCx bits (OSCCON<10:8>) for the new oscillator source.
4. Perform the unlock sequence to allow a write to the OSCCON register low byte.
5. Set the OSWEN bit to initiate the oscillator switch.

Once the basic sequence is completed, the system clock hardware responds automatically as follows:

1. The clock switching hardware compares the COSCx bits with the new value of the NOSCx bits. If they are the same, then the clock switch is a redundant operation. In this case, the OSWEN bit is cleared automatically and the clock switch is aborted.
2. If a valid clock switch has been initiated, the LOCK (OSCCON<5>) and CF (OSCCON<3>) bits are cleared.
3. The new oscillator is turned on by the hardware if it is not currently running. If a crystal oscillator must be turned on, the hardware will wait until the OST expires. If the new source is using the PLL, then the hardware waits until a PLL lock is detected (LOCK = 1).
4. The hardware waits for 10 clock cycles from the new clock source and then performs the clock switch.
5. The hardware clears the OSWEN bit to indicate a successful clock transition. In addition, the NOSCx bits value is transferred to the COSCx bits.
6. The old clock source is turned off at this time, with the exception of LPRC (if WDT, FSCM or RTCC with LPRC as clock source are enabled) or SOSC (if SOSSEN remains enabled).

**Note 1:** The processor will continue to execute code throughout the clock switching sequence. Timing-sensitive code should not be executed during this time.

- 2: Direct clock switches between any Primary Oscillator mode with PLL and FRCPLL mode are not permitted. This applies to clock switches in either direction. In these instances, the application must switch to FRC mode as a transition clock source between the two PLL modes.

# PIC24F16KA102 FAMILY

The following code sequence for a clock switch is recommended:

1. Disable interrupts during the OSCCON register unlock and write sequence.
2. Execute the unlock sequence for the OSCCON high byte by writing 78h and 9Ah to OSCCON<15:8> in two back-to-back instructions.
3. Write new oscillator source to the NOSCx bits in the instruction immediately following the unlock sequence.
4. Execute the unlock sequence for the OSCCON low byte by writing 46h and 57h to OSCCON<7:0> in two back-to-back instructions.
5. Set the OSWEN bit in the instruction immediately following the unlock sequence.
6. Continue to execute code that is not clock-sensitive (optional).
7. Invoke an appropriate amount of software delay (cycle counting) to allow the selected oscillator and/or PLL to start and stabilize.
8. Check to see if OSWEN is '0'. If it is, the switch was successful. If OSWEN is still set, then check the LOCK bit to determine the cause of failure.

The core sequence for unlocking the OSCCON register and initiating a clock switch is provided in [Example 9-1](#).

## EXAMPLE 9-1: BASIC CODE SEQUENCE FOR CLOCK SWITCHING

```
;Place the new oscillator selection in W0
;OSCCONH (high byte) Unlock Sequence
MOV    #OSCCONH, w1
MOV    #0x78, w2
MOV    #0x9A, w3
MOV.b  w2, [w1]
MOV.b  w3, [w1]
;Set new oscillator selection
MOV.b  WREG, OSCCONH
;OSCCONL (low byte) unlock sequence
MOV    #OSCCONL, w1
MOV    #0x46, w2
MOV    #0x57, w3
MOV.b  w2, [w1]
MOV.b  w3, [w1]
;Start oscillator switch operation
BSET   OSCCON,#0
```

## 9.5 Reference Clock Output

In addition to the CLKO output (Fosc/2) available in certain oscillator modes, the device clock in the PIC24F16KA102 family devices can also be configured to provide a reference clock output signal to a port pin. This feature is available in all oscillator configurations and allows the user to select a greater range of clock submultiples to drive external devices in the application.

This reference clock output is controlled by the REFOCON register ([Register 9-4](#)). Setting the ROEN bit (REFOCON<15>) makes the clock signal available on the REFO pin. The RODIV bits (REFOCON<11:8>) enable the selection of 16 different clock divider options.

The ROSSLP and ROSEL bits (REFOCON<13:12>) control the availability of the reference output during Sleep mode. The ROSEL bit determines if the oscillator on OSC1 and OSC2, or the current system clock source, is used for the reference clock output. The ROSSLP bit determines if the reference source is available on REFO when the device is in Sleep mode.

To use the reference clock output in Sleep mode, both the ROSSLP and ROSEL bits must be set. The device clock must also be configured for one of the primary modes (EC, HS or XT); otherwise, if the ROSEL bit is not also set, the oscillator on OSC1 and OSC2 will be powered down when the device enters Sleep mode. Clearing the ROSEL bit allows the reference output frequency to change as the system clock changes during any clock switches.

# PIC24F16KA102 FAMILY

## REGISTER 9-4: REFOCON: REFERENCE OSCILLATOR CONTROL REGISTER

R/W-0	U-0	R/W-0	R/W-0	R/W-0	R/W-0	R/W-0	R/W-0
ROEN	—	ROSSLP	ROSEL	RODIV3	RODIV2	RODIV1	RODIV0
bit 15							bit 8

U-0	U-0	U-0	U-0	U-0	U-0	U-0	U-0
—	—	—	—	—	—	—	—
bit 7							bit 0

### Legend:

R = Readable bit                      W = Writable bit                      U = Unimplemented bit, read as '0'  
 -n = Value at POR                      '1' = Bit is set                      '0' = Bit is cleared                      x = Bit is unknown

- bit 15        **ROEN:** Reference Oscillator Output Enable bit  
                  1 = Reference oscillator is enabled on REFO pin  
                  0 = Reference oscillator is disabled
- bit 14        **Unimplemented:** Read as '0'
- bit 13        **ROSSLP:** Reference Oscillator Output Stop in Sleep bit  
                  1 = Reference oscillator continues to run in Sleep  
                  0 = Reference oscillator is disabled in Sleep
- bit 12        **ROSEL:** Reference Oscillator Source Select bit  
                  1 = Primary oscillator is used as the base clock<sup>(1)</sup>  
                  0 = System clock is used as the base clock; base clock reflects any clock switching of the device
- bit 11-8      **RODIV<3:0>:** Reference Oscillator Divisor Select bits  
                  1111 = Base clock value divided by 32,768  
                  1110 = Base clock value divided by 16,384  
                  1101 = Base clock value divided by 8,192  
                  1100 = Base clock value divided by 4,096  
                  1011 = Base clock value divided by 2,048  
                  1010 = Base clock value divided by 1,024  
                  1001 = Base clock value divided by 512  
                  1000 = Base clock value divided by 256  
                  0111 = Base clock value divided by 128  
                  0110 = Base clock value divided by 64  
                  0101 = Base clock value divided by 32  
                  0100 = Base clock value divided by 16  
                  0011 = Base clock value divided by 8  
                  0010 = Base clock value divided by 4  
                  0001 = Base clock value divided by 2  
                  0000 = Base clock value
- bit 7-0        **Unimplemented:** Read as '0'

**Note 1:** The crystal oscillator must be enabled using the FOSC<2:0> bits; the crystal maintains the operation in Sleep mode.

# PIC24F16KA102 FAMILY

---

NOTES:

## 10.0 POWER-SAVING FEATURES

**Note:** This data sheet summarizes the features of this group of PIC24F devices. It is not intended to be a comprehensive reference source. For more information, refer to the “PIC24F Family Reference Manual”, “Section 39. Power-Saving Features with Deep Sleep” (DS39727).

The PIC24F16KA102 family of devices provides the ability to manage power consumption by selectively managing clocking to the CPU and the peripherals. In general, a lower clock frequency and a reduction in the number of circuits being clocked constitutes lower consumed power. All PIC24F devices manage power consumption in four different ways:

- Clock frequency
- Instruction-based Sleep, Idle and Deep Sleep modes
- Software controlled Doze mode
- Selective peripheral control in software

Combinations of these methods can be used to selectively tailor an application’s power consumption, while still maintaining critical application features, such as timing-sensitive communications.

### 10.1 Clock Frequency and Clock Switching

PIC24F devices allow for a wide range of clock frequencies to be selected under application control. If the system clock configuration is not locked, users can choose low-power or high-precision oscillators by simply changing the NOSC bits. The process of changing a system clock during operation, as well as limitations to the process, are discussed in more detail in [Section 9.0 “Oscillator Configuration”](#).

### 10.2 Instruction-Based Power-Saving Modes

PIC24F devices have two special power-saving modes that are entered through the execution of a special `PWRSVAV` instruction. Sleep mode stops clock operation and halts all code execution; Idle mode halts the CPU and code execution, but allows peripheral modules to continue operation. Deep Sleep mode stops clock operation, code execution and all peripherals except RTCC and DSWDT. It also freezes I/O states and removes power to SRAM and Flash memory.

The assembly syntax of the `PWRSVAV` instruction is shown in [Example 10-1](#).

**Note:** `SLEEP_MODE` and `IDLE_MODE` are constants, defined in the assembler include file, for the selected device.

Sleep and Idle modes can be exited as a result of an enabled interrupt, WDT time-out or a device Reset. When the device exits these modes, it is said to “wake-up”.

#### 10.2.1 SLEEP MODE

Sleep mode includes these features:

- The system clock source is shut down. If an on-chip oscillator is used, it is turned off.
- The device current consumption will be reduced to a minimum provided that no I/O pin is sourcing current.
- The I/O pin directions and states are frozen.
- The Fail-Safe Clock Monitor does not operate during Sleep mode since the system clock source is disabled.
- The LPRC clock will continue to run in Sleep mode if the WDT or RTCC, with LPRC as the clock source, is enabled.
- The WDT, if enabled, is automatically cleared prior to entering Sleep mode.
- Some device features or peripherals may continue to operate in Sleep mode. This includes items, such as the input change notification on the I/O ports, or peripherals that use an external clock input. Any peripheral that requires the system clock source for its operation will be disabled in Sleep mode.

The device will wake-up from Sleep mode on any of these events:

- On any interrupt source that is individually enabled
- On any form of device Reset
- On a WDT time-out

On wake-up from Sleep, the processor will restart with the same clock source that was active when Sleep mode was entered.

#### EXAMPLE 10-1: `PWRSVAV` INSTRUCTION SYNTAX

```
PWRSVAV    #SLEEP_MODE    ; Put the device into SLEEP mode
PWRSVAV    #IDLE_MODE     ; Put the device into IDLE mode
BSET       DSCON, #DSEN   ; Enable Deep Sleep
PWRSVAV    #SLEEP_MODE    ; Put the device into Deep SLEEP mode
```

# PIC24F16KA102 FAMILY

## 10.2.2 IDLE MODE

Idle mode has these features:

- The CPU will stop executing instructions.
- The WDT is automatically cleared.
- The system clock source remains active. By default, all peripheral modules continue to operate normally from the system clock source, but can also be selectively disabled (see [Section 10.4 “Selective Peripheral Module Control”](#)).
- If the WDT or FSCM is enabled, the LPRC will also remain active.

The device will wake from Idle mode on any of these events:

- Any interrupt that is individually enabled
- Any device Reset
- A WDT time-out

On wake-up from Idle, the clock is re-applied to the CPU and instruction execution begins immediately, starting with the instruction following the `PWRSAV` instruction or the first instruction in the ISR.

## 10.2.3 INTERRUPTS COINCIDENT WITH POWER SAVE INSTRUCTIONS

Any interrupt that coincides with the execution of a `PWRSAV` instruction will be held off until entry into Sleep or Idle mode has completed. The device will then wake-up from Sleep or Idle mode.

## 10.2.4 DEEP SLEEP MODE

In PIC24F16KA102 family devices, Deep Sleep mode is intended to provide the lowest levels of power consumption available without requiring the use of external switches to completely remove all power from the device. Entry into Deep Sleep mode is completely under software control. Exit from Deep Sleep mode can be triggered from any of the following events:

- POR event
- $\overline{\text{MCLR}}$  event
- RTCC alarm (if the RTCC is present)
- External Interrupt 0
- Deep Sleep Watchdog Timer (DSWDT) time-out

In Deep Sleep mode, it is possible to keep the device Real-Time Clock and Calendar (RTCC) running without the loss of clock cycles.

The device has a dedicated Deep Sleep Brown-out Reset (DSBOR) and a Deep Sleep Watchdog Timer Reset (DSWDT) for monitoring voltage and time-out events. The DSBOR and DSWDT are independent of the standard BOR and WDT used with other power-managed modes (Sleep, Idle and Doze).

### 10.2.4.1 Entering Deep Sleep Mode

Deep Sleep mode is entered by setting the DSEN bit in the DSCON register, and then executing a Sleep command (`PWRSAV #SLEEP_MODE`), within one instruction cycle, to minimize the chance that Deep Sleep will be spuriously entered.

If the `PWRSAV` command is not given within one instruction cycle, the DSEN bit will be cleared by the hardware and must be set again by the software before entering Deep Sleep mode. The DSEN bit is also automatically cleared when exiting the Deep Sleep mode.

<b>Note:</b> To re-enter Deep Sleep after a Deep Sleep wake-up, allow a delay of at least 3 $T_{CY}$ after clearing the RELEASE bit.
--------------------------------------------------------------------------------------------------------------------------------------

The sequence to enter Deep Sleep mode is:

1. If the application requires the Deep Sleep WDT, enable it and configure its clock source (see [Section 10.2.4.5 “Deep Sleep WDT”](#) for details).
2. If the application requires Deep Sleep BOR, enable it by programming the DSBORN Configuration bit (FDS<6>).
3. If the application requires wake-up from Deep Sleep on RTCC alarm, enable and configure the RTCC module (see [Section 19.0 “Real-Time Clock and Calendar \(RTCC\)”](#) for more information).
4. If needed, save any critical application context data by writing it to the DSGPR0 and DSGPR1 registers (optional).
5. Enable Deep Sleep mode by setting the DSEN bit (DSCON<15>).
6. Enter Deep Sleep mode by issuing 3 `NOP` commands, and then a `PWRSAV #0` instruction.

Any time the DSEN bit is set, all bits in the DSWAKE register will be automatically cleared.

## 10.2.4.2 Exiting Deep Sleep Mode

Deep Sleep mode exits on any one of the following events:

- POR event on V<sub>DD</sub> supply. If there is no DSBOR circuit to re-arm the V<sub>DD</sub> supply POR circuit, the external V<sub>DD</sub> supply must be lowered to the natural arming voltage of the POR circuit.
- DSWDT time-out. When the DSWDT timer times out, the device exits Deep Sleep.
- RTCC alarm (if RTCEN = 1).
- Assertion ('0') of the  $\overline{\text{MCLR}}$  pin.
- Assertion of the INT0 pin (if the interrupt was enabled before Deep Sleep mode was entered). The polarity configuration is used to determine the assertion level ('0' or '1') of the pin that will cause an exit from Deep Sleep mode. Exiting from Deep Sleep mode requires a change on the INT0 pin while in Deep Sleep mode.

**Note:** Any interrupt pending when entering Deep Sleep mode is cleared.

Exiting Deep Sleep mode generally does not retain the state of the device and is equivalent to a Power-on Reset (POR) of the device. Exceptions to this include the RTCC (if present), which remains operational through the wake-up, the DSGPRx registers and the DSWDT bit.

Wake-up events that occur from the time Deep Sleep exits until the time the POR sequence completes are ignored and are not be captured in the DSWAKE register.

The sequence for exiting Deep Sleep mode is:

1. After a wake-up event, the device exits Deep Sleep and performs a POR. The DSEN bit is cleared automatically. Code execution resumes at the Reset vector.
2. To determine if the device exited Deep Sleep, read the Deep Sleep bit, DP<sub>SLP</sub> (RCON<10>). This bit will be set if there was an exit from Deep Sleep mode; if the bit is set, clear it.
3. Determine the wake-up source by reading the DSWAKE register.
4. Determine if a DSBOR event occurred during Deep Sleep mode by reading the DSBOR bit (DSCON<1>).
5. If application context data has been saved, read it back from the DSGPR0 and DSGPR1 registers.
6. Clear the RELEASE bit (DSCON<0>).

## 10.2.4.3 Saving Context Data with the DSGPR0/DSGPR1 Registers

As exiting Deep Sleep mode causes a POR, most Special Function Registers reset to their default POR values. In addition, because V<sub>DDCORE</sub> power is not supplied in Deep Sleep mode, information in data RAM may be lost when exiting this mode.

Applications which require critical data to be saved prior to Deep Sleep may use the Deep Sleep General Purpose registers, DSGPR0 and DSGPR1, or data EEPROM (if available). Unlike other SFRs, the contents of these registers are preserved while the device is in Deep Sleep mode. After exiting Deep Sleep, software can restore the data by reading the registers and clearing the RELEASE bit (DSCON<0>).

## 10.2.4.4 I/O Pins During Deep Sleep

During Deep Sleep, the general purpose I/O pins retain their previous states and the Secondary Oscillator (SOSC) will remain running, if enabled. Pins that are configured as inputs (TRISx bit set), prior to entry into Deep Sleep, remain high-impedance during Deep Sleep. Pins that are configured as outputs (TRISx bit clear), prior to entry into Deep Sleep, remain as output pins during Deep Sleep. While in this mode, they continue to drive the output level determined by their corresponding LATx bit at the time of entry into Deep Sleep.

Once the device wakes back up, all I/O pins continue to maintain their previous states, even after the device has finished the POR sequence and is executing application code again. Pins configured as inputs during Deep Sleep remain high-impedance and pins configured as outputs continue to drive their previous value. After waking up, the TRIS and LAT registers, and the SOSCEN bit (OSCCON<1>) are reset. If firmware modifies any of these bits or registers, the I/O will not immediately go to the newly configured states. Once the firmware clears the RELEASE bit (DSCON<0>), the I/O pins are "released". This causes the I/O pins to take the states configured by their respective TRIS and LAT bit values.

This means that keeping the SOSC running after waking up requires the SOSCEN bit to be set before clearing RELEASE.

If the Deep Sleep BOR (DSBOR) is enabled, and a DSBOR or a true POR event occurs during Deep Sleep, the I/O pins will be immediately released, similar to clearing the RELEASE bit. All previous state information will be lost, including the general purpose DSGPR0 and DSGPR1 contents.

If a  $\overline{\text{MCLR}}$  Reset event occurs during Deep Sleep, the DSGPRx, DSCON and DSWAKE registers will remain valid, and the RELEASE bit will remain set. The state of the SOSC will also be retained. The I/O pins, however, will be reset to their  $\overline{\text{MCLR}}$  Reset state. Since RELEASE is still set, changes to the SOSCEN bit (OSCCON<1>) cannot take effect until the RELEASE bit is cleared.

In all other Deep Sleep wake-up cases, application firmware must clear the RELEASE bit in order to reconfigure the I/O pins.

# PIC24F16KA102 FAMILY

---

## 10.2.4.5 Deep Sleep WDT

To enable the DSWDT in Deep Sleep mode, program the Configuration bit, DSWDTEN (FDS<7>). The device Watchdog Timer (WDT) need not be enabled for the DSWDT to function. Entry into Deep Sleep mode automatically resets the DSWDT.

The DSWDT clock source is selected by the DSWDTOSC Configuration bit (FDS<4>). The post-scaler options are programmed by the DSWDTPS<3:0> Configuration bits (FDS<3:0>). The minimum time-out period that can be achieved is 2.1 ms and the maximum is 25.7 days. For more details on the FDS Configuration register and DSWDT configuration options, refer to [Section 26.0 “Special Features”](#).

## 10.2.4.6 Switching Clocks in Deep Sleep Mode

Both the RTCC and the DSWDT may run from either SOSC or the LPRC clock source. This allows both the RTCC and DSWDT to run without requiring both the LPRC and SOSC to be enabled together, reducing power consumption.

Running the RTCC from LPRC will result in a loss of accuracy in the RTCC of approximately 5 to 10%. If a more accurate RTCC is required, it must be run from the SOSC clock source. The RTCC clock source is selected with the RTCOSC Configuration bit (FDS<5>).

Under certain circumstances, it is possible for the DSWDT clock source to be off when entering Deep Sleep mode. In this case, the clock source is turned on automatically (if DSWDT is enabled), without the need for software intervention. However, this can cause a delay in the start of the DSWDT counters. In order to avoid this delay when using SOSC as a clock source, the application can activate SOSC prior to entering Deep Sleep mode.

## 10.2.4.7 Checking and Clearing the Status of Deep Sleep

Upon entry into Deep Sleep mode, the status bit DPSTP (RCON<10>), becomes set and must be cleared by software.

On power-up, the software should read this status bit to determine if the Reset was due to an exit from Deep Sleep mode and clear the bit if it is set. Of the four possible combinations of DPSTP and POR bit states, three cases can be considered:

- Both the DPSTP and POR bits are cleared. In this case, the Reset was due to some event other than a Deep Sleep mode exit.
- The DPSTP bit is clear, but the POR bit is set. This is a normal POR.
- Both the DPSTP and POR bits are set. This means that Deep Sleep mode was entered, the device was powered down and Deep Sleep mode was exited.

## 10.2.4.8 Power-on Resets (PORs)

VDD voltage is monitored to produce PORs. Since exiting from Deep Sleep functionally looks like a POR, the technique described in [Section 10.2.4.7 “Checking and Clearing the Status of Deep Sleep”](#) should be used to distinguish between Deep Sleep and a true POR event.

When a true POR occurs, the entire device, including all Deep Sleep logic (Deep Sleep registers, RTCC, DSWDT, etc.) is reset.

## 10.2.4.9 Summary of Deep Sleep Sequence

To review, these are the necessary steps involved in invoking and exiting Deep Sleep mode:

1. Device exits Reset and begins to execute its application code.
2. If DSWDT functionality is required, program the appropriate Configuration bit.
3. Select the appropriate clock(s) for the DSWDT and RTCC (optional).
4. Enable and configure the DSWDT (optional).
5. Enable and configure the RTCC (optional).
6. Write context data to the DSGPRx registers (optional).
7. Enable the INT0 interrupt (optional).
8. Set the DSEN bit in the DSCON register.
9. Enter Deep Sleep by issuing a PWRSV #SLEEP\_MODE command.
10. Device exits Deep Sleep when a wake-up event occurs.
11. The DSEN bit is automatically cleared.
12. Read and clear the DPSTP status bit in RCON, and the DS\_WAKE status bits.
13. Read the DSGPRx registers (optional).
14. Once all state related configurations are complete, clear the RELEASE bit.
15. Application resumes normal operation.



# PIC24F16KA102 FAMILY

## REGISTER 10-1: DSCON: DEEP SLEEP CONTROL REGISTER<sup>(1)</sup>

R/W-0	U-0	U-0	U-0	U-0	U-0	U-0	U-0
DSEN	—	—	—	—	—	—	—
bit 15							bit 8

U-0	U-0	U-0	U-0	U-0	U-0	R/W-0	R/C-0, HS
—	—	—	—	—	—	DSBOR <sup>(2)</sup>	RELEASE
bit 7							bit 0

<b>Legend:</b>	C = Clearable bit	HS = Hardware Settable bit
R = Readable bit	W = Writable bit	U = Unimplemented bit, read as '0'
-n = Value at POR	'1' = Bit is set	'0' = Bit is cleared    x = Bit is unknown

- bit 15     **DSEN:** Deep Sleep Enable bit  
1 = Enters Deep Sleep on execution of PWRSAV #0  
0 = Enters normal Sleep on execution of PWRSAV #0
- bit 14-2   **Unimplemented:** Read as '0'
- bit 1     **DSBOR:** Deep Sleep BOR Event bit<sup>(2)</sup>  
1 = The DSBOR was active and a BOR event was detected during Deep Sleep  
0 = The DSBOR was not active, or was active but did not detect a BOR event during Deep Sleep
- bit 0     **RELEASE:** I/O Pin State Release bit  
1 = Upon waking from Deep Sleep, I/O pins maintain their states previous to Deep Sleep entry  
0 = Release I/O pins from their state previous to Deep Sleep entry, and allow their respective TRIS and LAT bits to control their states

- Note 1:** All register bits are reset only in the case of a POR event outside of Deep Sleep mode.
- 2:** Unlike all other events, a Deep Sleep BOR event will NOT cause a wake-up from Deep Sleep; this re-arms POR.

# PIC24F16KA102 FAMILY

## REGISTER 10-2: DSWAKE: DEEP SLEEP WAKE-UP SOURCE REGISTER<sup>(1)</sup>

U-0	U-0	U-0	U-0	U-0	U-0	U-0	R/W-0, HS
—	—	—	—	—	—	—	DSINT0
bit 15							bit 8

R/W-0, HS	U-0	U-0	R/W-0, HS	R/W-0, HS	R/W-0, HS	U-0	R/W-0, HS
DSFLT	—	—	DSWDT	DSRTCC	DSMCLR	—	DSPOR <sup>(2,3)</sup>
bit 7							bit 0

<b>Legend:</b>	HS = Hardware Settable bit
R = Readable bit	W = Writable bit
-n = Value at POR	'1' = Bit is set
	U = Unimplemented bit, read as '0'
	'0' = Bit is cleared
	x = Bit is unknown

- bit 15-9     **Unimplemented:** Read as '0'
- bit 8        **DSINT0:** Interrupt-on-Change bit  
 1 = Interrupt-on-change was asserted during Deep Sleep  
 0 = Interrupt-on-change was not asserted during Deep Sleep
- bit 7        **DSFLT:** Deep Sleep Fault Detected bit  
 1 = A Fault occurred during Deep Sleep, and some Deep Sleep configuration settings may have been corrupted  
 0 = No Fault was detected during Deep Sleep
- bit 6-5     **Unimplemented:** Read as '0'
- bit 4        **DSWDT:** Deep Sleep Watchdog Timer Time-out bit  
 1 = The Deep Sleep Watchdog Timer timed out during Deep Sleep  
 0 = The Deep Sleep Watchdog Timer did not time out during Deep Sleep
- bit 3        **DSRTCC:** Real-Time Clock and Calendar Alarm bit  
 1 = The Real-Time Clock and Calendar triggered an alarm during Deep Sleep  
 0 = The Real-Time Clock and Calendar did not trigger an alarm during Deep Sleep
- bit 2        **DSMCLR:**  $\overline{\text{MCLR}}$  Event bit  
 1 = The  $\overline{\text{MCLR}}$  pin was active and was asserted during Deep Sleep  
 0 = The  $\overline{\text{MCLR}}$  pin was not active, or was active, but not asserted during Deep Sleep
- bit 1        **Unimplemented:** Read as '0'
- bit 0        **DSPOR:** Power-on Reset Event bit<sup>(2,3)</sup>  
 1 = The V<sub>DD</sub> supply POR circuit was active and a POR event was detected  
 0 = The V<sub>DD</sub> supply POR circuit was not active, or was active but did not detect a POR event

- Note 1:** All register bits are cleared when the DSCON<DSEN> bit is set.
- Note 2:** All register bits are reset only in the case of a POR event outside Deep Sleep mode, except bit, DSPOR, which does not reset on a POR event that is caused due to a Deep Sleep exit.
- Note 3:** Unlike the other bits in this register, this bit can be set outside of Deep Sleep.

## 10.3 Doze Mode

Generally, changing clock speed and invoking one of the power-saving modes are the preferred strategies for reducing power consumption. There may be circumstances, however, where this is not practical. For example, it may be necessary for an application to maintain uninterrupted synchronous communication, even while it is doing nothing else. Reducing system clock speed may introduce communication errors, while using a power-saving mode may stop communications completely.

Doze mode is a simple and effective alternative method to reduce power consumption while the device is still executing code. In this mode, the system clock continues to operate from the same source and at the same speed. Peripheral modules continue to be clocked at the same speed while the CPU clock speed is reduced. Synchronization between the two clock domains is maintained, allowing the peripherals to access the SFRs while the CPU executes code at a slower rate.

Doze mode is enabled by setting the DOZEN bit (CLKDIV<11>). The ratio between peripheral and core clock speed is determined by the DOZE<2:0> bits (CLKDIV<14:12>). There are eight possible configurations, from 1:1 to 1:128, with 1:1 being the default.

It is also possible to use Doze mode to selectively reduce power consumption in event driven applications. This allows clock-sensitive functions, such as synchronous communications, to continue without interruption while the CPU Idles, waiting for something to invoke an interrupt routine. Enabling the automatic return to full-speed CPU operation on interrupts is enabled by setting the ROI bit (CLKDIV<15>). By default, interrupt events have no effect on Doze mode operation.

## 10.4 Selective Peripheral Module Control

Idle and Doze modes allow users to substantially reduce power consumption by slowing or stopping the CPU clock. Even so, peripheral modules still remain clocked, and thus, consume power. There may be cases where the application needs what these modes do not provide: the allocation of power resources to CPU processing with minimal power consumption from the peripherals.

PIC24F devices address this requirement by allowing peripheral modules to be selectively disabled, reducing or eliminating their power consumption. This can be done with two control bits:

- The Peripheral Enable bit, generically named, “XXXEN”, located in the module’s main control SFR.
- The Peripheral Module Disable (PMD) bit, generically named, “XXXMD”, located in one of the PMD Control registers.

Both bits have similar functions in enabling or disabling its associated module. Setting the PMD bit for a module disables all clock sources to that module, reducing its power consumption to an absolute minimum. In this state, the control and status registers associated with the peripheral will also be disabled, so writes to those registers will have no effect and read values will be invalid. Many peripheral modules have a corresponding PMD bit.

In contrast, disabling a module by clearing its XXXEN bit disables its functionality, but leaves its registers available to be read and written to. Power consumption is reduced, but not by as much as the PMD bits are used. Most peripheral modules have an enable bit; exceptions include capture, compare and RTCC.

To achieve more selective power savings, peripheral modules can also be selectively disabled when the device enters Idle mode. This is done through the control bit of the generic name format, “XXXIDL”. By default, all modules that can operate during Idle mode will do so. Using the disable on Idle feature disables the module while in Idle mode, allowing further reduction of power consumption during Idle mode, enhancing power savings for extremely critical power applications.

# PIC24F16KA102 FAMILY

## REGISTER 10-3: PMD1: PERIPHERAL MODULE DISABLE REGISTER 1

U-0	U-0	R/W-0	R/W-0	R/W-0	U-0	U-0	U-0
—	—	T3MD	T2MD	T1MD	—	—	—
bit 15						bit 8	

R/W-0	R/W-0	R/W-0	U-0	R/W-0	U-0	U-0	R/W-0
I2C1MD	U2MD	U1MD	—	SPI1MD	—	—	ADC1MD
bit 7						bit 0	

### Legend:

R = Readable bit                      W = Writable bit                      U = Unimplemented bit, read as '0'  
 -n = Value at POR                      '1' = Bit is set                      '0' = Bit is cleared                      x = Bit is unknown

- bit 15-14     **Unimplemented:** Read as '0'
- bit 13        **T3MD:** Timer3 Module Disable bit  
                  1 = Timer3 module is disabled. All Timer3 registers are held in Reset and are not writable.  
                  0 = Timer3 module is enabled
- bit 12        **T2MD:** Timer2 Module Disable bit  
                  1 = Timer2 module is disabled. All Timer2 registers are held in Reset and are not writable.  
                  0 = Timer2 module is enabled
- bit 11        **T1MD:** Timer1 Module Disable bit  
                  1 = Timer1 module is disabled. All Timer1 registers are held in Reset and are not writable.  
                  0 = Timer1 module is enabled
- bit 10-8     **Unimplemented:** Read as '0'
- bit 7         **I2C1MD:** I2C1 Module Disable bit  
                  1 = I2C1 module is disabled. All I2C1 registers are held in Reset and are not writable.  
                  0 = I2C1 module is enabled
- bit 6         **U2MD:** UART2 Module Disable bit  
                  1 = UART2 module is disabled. All UART2 registers are held in Reset and are not writable.  
                  0 = UART2 module is enabled
- bit 5         **U1MD:** UART1 Module Disable bit  
                  1 = UART1 module is disabled. All UART1 registers are held in Reset and are not writable.  
                  0 = UART1 module is enabled
- bit 4         **Unimplemented:** Read as '0'
- bit 3         **SPI1MD:** SPI1 Module Disable bit  
                  1 = SPI1 module is disabled. All SPI1 registers are held in Reset and are not writable.  
                  0 = SPI1 module is enabled
- bit 2-1      **Unimplemented:** Read as '0'
- bit 0         **ADC1MD:** A/D Module Disable bit  
                  1 = A/D module is disabled. All A/D registers are held in Reset and are not writable.  
                  0 = A/D module is enabled

# PIC24F16KA102 FAMILY

## REGISTER 10-4: PMD2: PERIPHERAL MODULE DISABLE REGISTER 2

U-0	U-0	U-0	U-0	U-0	U-0	U-0	R/W-0
—	—	—	—	—	—	—	I2C1MD
bit 15							bit 8

U-0	U-0	U-0	U-0	U-0	U-0	U-0	R/W-0
—	—	—	—	—	—	—	OC1MD
bit 7							bit 0

### Legend:

R = Readable bit

W = Writable bit

U = Unimplemented bit, read as '0'

-n = Value at POR

'1' = Bit is set

'0' = Bit is cleared

x = Bit is unknown

bit 15-9 **Unimplemented:** Read as '0'

bit 8 **I2C1MD:** Input Capture 1 Module Disable bit

1 = Input Capture 1 module is disabled. All Input Capture registers are held in Reset and are not writable.

0 = Input Capture 1 module is writable

bit 7-1 **Unimplemented:** Read as '0'

bit 0 **OC1MD:** Input Compare 1 Module Disable bit

1 = Output Compare 1 module is disabled. All Output Compare registers are held in Reset and are not writable.

0 = Output Compare 1 module is writable

# PIC24F16KA102 FAMILY

## REGISTER 10-5: PMD3: PERIPHERAL MODULE DISABLE REGISTER 3

U-0	U-0	U-0	U-0	U-0	R/W-0	R/W-0	U-0
—	—	—	—	—	CMPMD	RTCCMD	—
bit 15						bit 8	

R/W-0	U-0	U-0	U-0	U-0	U-0	U-0	U-0
CRCMD	—	—	—	—	—	—	—
bit 7						bit 0	

### Legend:

R = Readable bit                      W = Writable bit                      U = Unimplemented bit, read as '0'  
 -n = Value at POR                      '1' = Bit is set                      '0' = Bit is cleared                      x = Bit is unknown

- bit 15-11      **Unimplemented:** Read as '0'
- bit 10        **CMPMD:** Comparator Module Disable bit  
                  1 = Comparator module is disabled. All Comparator Module registers are held in Reset and are not writable.  
                  0 = Comparator module is enabled
- bit 9         **RTCCMD:** RTCC Module Disable bit  
                  1 = RTCC module is disabled. All RTCC module registers are held in Reset and are not writable.  
                  0 = RTCC module is enabled
- bit 8         **Unimplemented:** Read as '0'
- bit 7         **CRCMD:** CRC Module Disable bit  
                  1 = CRC module is disabled. All CRC registers are held in Reset and are not writable.  
                  0 = CRC module is enabled
- bit 6-0      **Unimplemented:** Read as '0'

# PIC24F16KA102 FAMILY

## REGISTER 10-6: PMD4: PERIPHERAL MODULE DISABLE REGISTER 4

U-0	U-0	U-0	U-0	U-0	U-0	U-0	U-0
—	—	—	—	—	—	—	—
bit 15						bit 8	

U-0	U-0	U-0	R/W-0	R/W-0	R/W-0	R/W-0	U-0
—	—	—	EEMD	REFOMD	CTMUMD	HLVDMD	—
bit 7						bit 0	

### Legend:

R = Readable bit                      W = Writable bit                      U = Unimplemented bit, read as '0'  
 -n = Value at POR                      '1' = Bit is set                      '0' = Bit is cleared                      x = Bit is unknown

- bit 15-5      **Unimplemented:** Read as '0'
- bit 4      **EEMD:** EEPROM Memory Module Disable bit  
             1 = Disable EEPROM memory Flash panel, minimizing current consumption  
             0 = EEPROM memory is disabled
- bit 3      **REFOMD:** Reference Oscillator Module Disable bit  
             1 = Reference oscillator module is disabled. All Reference Oscillator registers are held in Reset and are not writable  
             0 = Reference Oscillator module is enabled
- bit 2      **CTMUMD:** CTMU Module Disable bit  
             1 = CTMU module is disabled. All CTMU registers are held in Reset and are not writable.  
             0 = CTMU module is enabled
- bit 1      **HLVDMD:** HLVD Module Disable bit  
             1 = HLVD module is disabled. All HLVD registers are held in Reset and are not writable.  
             0 = HLVD module is enabled
- bit 0      **Unimplemented:** Read as '0'

# PIC24F16KA102 FAMILY

---

NOTES:



# PIC24F16KA102 FAMILY

## 11.0 I/O PORTS

**Note:** This data sheet summarizes the features of this group of PIC24F devices. It is not intended to be a comprehensive reference source. For more information on the I/O ports, refer to the “PIC24F Family Reference Manual”, Section 12. “I/O Ports with Peripheral Pin Select (PPS)” (DS39711). Note that the PIC24F16KA102 family devices do not support Peripheral Pin Select features.

All of the device pins (except VDD and VSS) are shared between the peripherals and the parallel I/O ports. All I/O input ports feature Schmitt Trigger inputs for improved noise immunity.

### 11.1 Parallel I/O (PIO) Ports

A parallel I/O port that shares a pin with a peripheral is, in general, subservient to the peripheral. The peripheral’s output buffer data and control signals are provided to a pair of multiplexers. The multiplexers select whether the peripheral or the associated port has ownership of the output data and control signals of the I/O pin. The logic also prevents “loop through”, in which a port’s digital output can drive the input of a peripheral that shares the same pin. Figure 11-1 displays how ports are shared with other peripherals and the associated I/O pin to which they are connected.

When a peripheral is enabled and the peripheral is actively driving an associated pin, the use of the pin as a general purpose output pin is disabled. The I/O pin may be read, but the output driver for the parallel port bit will be disabled. If a peripheral is enabled, but the peripheral is not actively driving a pin, that pin may be driven by a port.

All port pins have three registers directly associated with their operation as digital I/O. The Data Direction register (TRISx) determines whether the pin is an input or an output. If the data direction bit is a ‘1’, then the pin is an input. All port pins are defined as inputs after a Reset. Reads from the Data Latch register (LATx), read the latch. Writes to the latch, write the latch. Reads from the port (PORTx), read the port pins, while writes to the port pins, write the latch.

Any bit and its associated data and control registers that are not valid for a particular device will be disabled. That means the corresponding LATx and TRISx registers, and the port pin will read as zeros.

When a pin is shared with another peripheral or function that is defined as an input only, it is nevertheless regarded as a dedicated port because there is no other competing source of outputs.

**Note:** The I/O pins retain their state during Deep Sleep. They will retain this state at wake-up until the software restore bit (RELEASE) is cleared.

FIGURE 11-1: BLOCK DIAGRAM OF A TYPICAL SHARED PORT STRUCTURE



# PIC24F16KA102 FAMILY

## 11.1.1 OPEN-DRAIN CONFIGURATION

In addition to the PORT, LAT and TRIS registers for data control, each port pin can also be individually configured for either digital or open-drain output. This is controlled by the Open-Drain Control register, ODCx, associated with each port. Setting any of the bits configures the corresponding pin to act as an open-drain output.

The maximum open-drain voltage allowed is the same as the maximum V<sub>IH</sub> specification.

## 11.2 Configuring Analog Port Pins

The use of the AD1PCFG and TRIS register controls the operation of the A/D port pins. The port pins that are desired as analog inputs must have their corresponding TRIS bit set (input). If the TRIS bit is cleared (output), the digital output level (V<sub>OH</sub> or V<sub>OL</sub>) will be converted.

When reading the PORT register, all pins configured as analog input channels will read as cleared (a low level). Analog levels on any pin that is defined as a digital input (including the ANx pins) may cause the input buffer to consume current that exceeds the device specifications.

### 11.2.1 I/O PORT WRITE/READ TIMING

One instruction cycle is required between a port direction change or port write operation and a read operation of the same port. Typically, this instruction would be a NOP.

## 11.3 Input Change Notification

The input change notification function of the I/O ports allows the PIC24F16KA102 family of devices to generate interrupt requests to the processor in response to a Change-of-State (COS) on selected input pins. This feature is capable of detecting input Change-of-States even in Sleep mode, when the

clocks are disabled. Depending on the device pin count, there are up to 23 external signals (CN0 through CN22) that may be selected (enabled) for generating an interrupt request on a Change-of-State.

There are six control registers associated with the CN module. The CNEN1 and CNEN2 registers contain the interrupt enable control bits for each of the CN input pins. Setting any of these bits enables a CN interrupt for the corresponding pins.

Each CN pin also has a weak pull-up/pull-down connected to it. The pull-ups act as a current source that is connected to the pin and the pull-downs act as a current sink to eliminate the need for external resistors when push button or keypad devices are connected.

On any pin, only the pull-up resistor or the pull-down resistor should be enabled, but not both of them. If the push button or the keypad is connected to V<sub>DD</sub>, enable the pull-down, or if they are connected to V<sub>SS</sub>, enable the pull-up resistors. The pull-ups are enabled separately using the CNPU1 and CNPU2 registers, which contain the control bits for each of the CN pins.

Setting any of the control bits enables the weak pull-ups for the corresponding pins. The pull-downs are enabled separately using the CNPD1 and CNPD2 registers, which contain the control bits for each of the CN pins. Setting any of the control bits enables the weak pull-downs for the corresponding pins.

When the internal pull-up is selected, the pin uses V<sub>DD</sub> as the pull-up source voltage. When the internal pull-down is selected, the pins are pulled down to V<sub>SS</sub> by an internal resistor. Make sure that there is no external pull-up source/pull-down sink when the internal pull-ups/pull-downs are enabled.

**Note:** Pull-ups and pull-downs on change notification pins should always be disabled whenever the port pin is configured as a digital output.

### EXAMPLE 11-1: PORT WRITE/READ EXAMPLE

```
MOV    0xFF00, W0;           //Configure PORTB<15:8> as inputs and PORTB<7:0> as outputs
MOV    W0, TRISBB;
NOP;                          //Delay 1 cycle
BTSS   PORTB, #13;          //Next Instruction
```

#### Equivalent 'C' Code

```
TRISB = 0xFF00;           //Configure PORTB<15:8> as inputs and PORTB<7:0> as outputs
NOP();                    //Delay 1 cycle
if(PORTBbits.RB13 == 1)  // execute following code if PORTB pin 13 is set.
{
}
```

# PIC24F16KA102 FAMILY

## 12.0 TIMER1

**Note:** This data sheet summarizes the features of this group of PIC24F devices. It is not intended to be a comprehensive reference source. For more information on Timers, refer to the "PIC24F Family Reference Manual", **Section 14. "Timers"** (DS39704).

The Timer1 module is a 16-bit timer which can serve as the time counter for the Real-Time Clock (RTC), or operate as a free-running, interval timer/counter. Timer1 can operate in three modes:

- 16-Bit Timer
- 16-Bit Synchronous Counter
- 16-Bit Asynchronous Counter

Timer1 also supports these features:

- Timer Gate Operation
- Selectable Prescaler Settings
- Timer Operation During CPU Idle and Sleep modes
- Interrupt on 16-Bit Period Register Match or Falling Edge of External Gate Signal

Figure 12-1 presents a block diagram of the 16-bit Timer1 module.

To configure Timer1 for operation:

1. Set the TON bit (= 1).
2. Select the timer prescaler ratio using the TCKPS<1:0> bits.
3. Set the Clock and Gating modes using the TCS and TGATE bits.
4. Set or clear the TSYNC bit to configure synchronous or asynchronous operation.
5. Load the timer period value into the PR1 register.
6. If interrupts are required, set the interrupt enable bit, T1IE. Use the priority bits, T1IP<2:0>, to set the interrupt priority.

**FIGURE 12-1: 16-BIT TIMER1 MODULE BLOCK DIAGRAM**

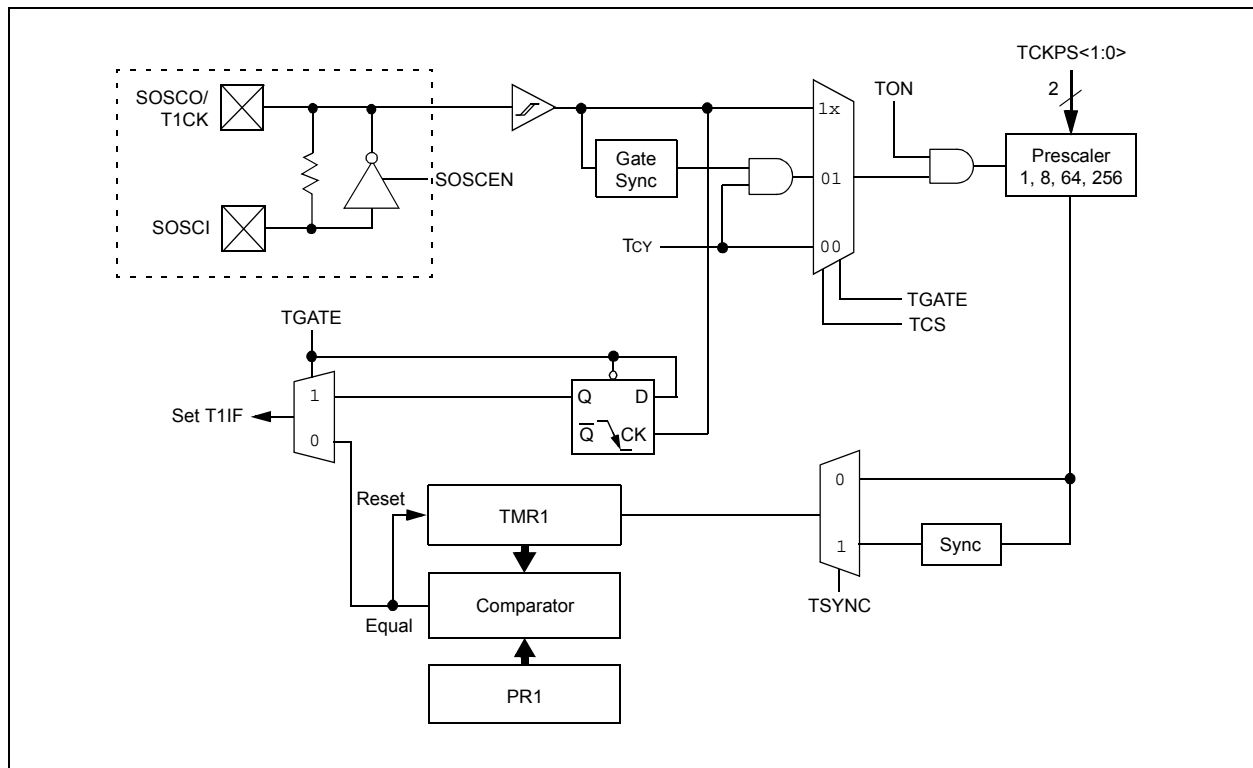

# PIC24F16KA102 FAMILY

## REGISTER 12-1: T1CON: TIMER1 CONTROL REGISTER

R/W-0	U-0	R/W-0	U-0	U-0	U-0	U-0	U-0
TON	—	TSIDL	—	—	—	—	—
bit 15						bit 8	

U-0	R/W-0	R/W-0	R/W-0	U-0	R/W-0	R/W-0	U-0
—	TGATE	TCKPS1	TCKPS0	—	TSYNC	TCS	—
bit 7						bit 0	

### Legend:

R = Readable bit                      W = Writable bit                      U = Unimplemented bit, read as '0'  
 -n = Value at POR                      '1' = Bit is set                      '0' = Bit is cleared                      x = Bit is unknown

- bit 15            **TON:** Timer1 On bit  
                   1 = Starts 16-bit Timer1  
                   0 = Stops 16-bit Timer1
- bit 14            **Unimplemented:** Read as '0'
- bit 13            **TSIDL:** Stop in Idle Mode bit  
                   1 = Discontinue module operation when device enters Idle mode  
                   0 = Continue module operation in Idle mode
- bit 12-7        **Unimplemented:** Read as '0'
- bit 6            **TGATE:** Timer1 Gated Time Accumulation Enable bit  
                   When TCS = 1:  
                   This bit is ignored.  
                   When TCS = 0:  
                   1 = Gated time accumulation is enabled  
                   0 = Gated time accumulation is disabled
- bit 5-4        **TCKPS<1:0>:** Timer1 Input Clock Prescale Select bits  
                   11 = 1:256  
                   10 = 1:64  
                   01 = 1:8  
                   00 = 1:1
- bit 3            **Unimplemented:** Read as '0'
- bit 2            **TSYNC:** Timer1 External Clock Input Synchronization Select bit  
                   When TCS = 1:  
                   1 = Synchronize external clock input  
                   0 = Do not synchronize external clock input  
                   When TCS = 0:  
                   This bit is ignored.
- bit 1            **TCS:** Timer1 Clock Source Select bit  
                   1 = External clock from T1CK pin (on the rising edge)  
                   0 = Internal clock (Fosc/2)
- bit 0            **Unimplemented:** Read as '0'

## 13.0 TIMER2/3

**Note:** This data sheet summarizes the features of this group of PIC24F devices. It is not intended to be a comprehensive reference source. For more information on Timers, refer to the "PIC24F Family Reference Manual", **Section 14. "Timers"** (DS39704).

The Timer2/3 module is a 32-bit timer, which can also be configured as two independent 16-bit timers with selectable operating modes.

As a 32-bit timer, Timer2/3 operates in three modes:

- Two independent 16-bit timers (Timer2 and Timer3) with all 16-bit operating modes (except Asynchronous Counter mode)
- Single 32-bit timer
- Single 32-bit synchronous counter

They also support these features:

- Timer gate operation
- Selectable prescaler settings
- Timer operation during Idle and Sleep modes
- Interrupt on a 32-bit Period register match
- A/D Event Trigger

Individually, both of the 16-bit timers can function as synchronous timers or counters. They also offer the features listed above, except for the A/D event trigger (this is implemented only with Timer3). The operating modes and enabled features are determined by setting the appropriate bit(s) in the T2CON and T3CON registers. T2CON and T3CON are provided in generic form in [Register 13-1](#) and [Register 13-2](#), respectively.

For 32-bit timer/counter operation, Timer2 is the least significant word (lsw) and Timer3 is the most significant word (msw) of the 32-bit timer.

**Note:** For 32-bit operation, T3CON control bits are ignored. Only T2CON control bits are used for setup and control. Timer2 clock and gate inputs are utilized for the 32-bit timer modules, but an interrupt is generated with the Timer3 interrupt flags.

To configure Timer2/3 for 32-bit operation:

1. Set the T32 bit (T2CON<3> = 1).
2. Select the prescaler ratio for Timer2 using the TCKPS<1:0> bits.
3. Set the Clock and Gating modes using the TCS and TGATE bits.
4. Load the timer period value. PR3 will contain the msw of the value while PR2 contains the lsw.
5. If interrupts are required, set the interrupt enable bit, T3IE. Use the priority bits, T3IP<2:0>, to set the interrupt priority.

While Timer2 controls the timer, the interrupt appears as a Timer3 interrupt.

6. Set the TON bit (= 1).

The timer value, at any point, is stored in the register pair, TMR<3:2>. TMR3 always contains the msw of the count, while TMR2 contains the lsw.

To configure any of the timers for individual 16-bit operation:

1. Clear the T32 bit in T2CON<3>.
2. Select the timer prescaler ratio using the TCKPS<1:0> bits.
3. Set the Clock and Gating modes using the TCS and TGATE bits.
4. Load the timer period value into the PRx register.
5. If interrupts are required, set the interrupt enable bit, TxIE; use the priority bits, TxIP<2:0>, to set the interrupt priority.
6. Set the TON bit (TxCON<15> = 1).

# PIC24F16KA102 FAMILY

**FIGURE 13-1: TIMER2/3 (32-BIT) BLOCK DIAGRAM**



# PIC24F16KA102 FAMILY

**FIGURE 13-2: TIMER2 (16-BIT SYNCHRONOUS) BLOCK DIAGRAM**



**FIGURE 13-3: TIMER3 (16-BIT SYNCHRONOUS) BLOCK DIAGRAM**



# PIC24F16KA102 FAMILY

## REGISTER 13-1: T2CON: TIMER2 CONTROL REGISTER

R/W-0	U-0	R/W-0	U-0	U-0	U-0	U-0	U-0
TON	—	TSIDL	—	—	—	—	—
bit 15							bit 8

U-0	R/W-0	R/W-0	R/W-0	R/W-0	U-0	R/W-0	U-0
—	TGATE	TCKPS1	TCKPS0	T32 <sup>(1)</sup>	—	TCS	—
bit 7							bit 0

### Legend:

R = Readable bit

W = Writable bit

U = Unimplemented bit, read as '0'

-n = Value at POR

'1' = Bit is set

'0' = Bit is cleared

x = Bit is unknown

- bit 15      **TON:** Timer2 On bit  
When T2CON<3> = 1:  
 1 = Starts 32-bit Timer2/3  
 0 = Stops 32-bit Timer2/3  
When T2CON<3> = 0:  
 1 = Starts 16-bit Timer2  
 0 = Stops 16-bit Timer2
- bit 14      **Unimplemented:** Read as '0'
- bit 13      **TSIDL:** Stop in Idle Mode bit  
 1 = Discontinue module operation when device enters Idle mode  
 0 = Continue module operation in Idle mode
- bit 12-7    **Unimplemented:** Read as '0'
- bit 6        **TGATE:** Timer2 Gated Time Accumulation Enable bit  
When TCS = 1:  
 This bit is ignored.  
When TCS = 0:  
 1 = Gated time accumulation is enabled  
 0 = Gated time accumulation is disabled
- bit 5-4     **TCKPS<1:0>:** Timer2 Input Clock Prescale Select bits  
 11 = 1:256  
 10 = 1:64  
 01 = 1:8  
 00 = 1:1
- bit 3        **T32:** 32-Bit Timer Mode Select bit<sup>(1)</sup>  
 1 = Timer2 and Timer3 form a single 32-bit timer  
 0 = Timer2 and Timer3 act as two 16-bit timers
- bit 2        **Unimplemented:** Read as '0'
- bit 1        **TCS:** Timer2 Clock Source Select bit  
 1 = External clock from pin, T2CK (on the rising edge)  
 0 = Internal clock (Fosc/2)
- bit 0        **Unimplemented:** Read as '0'

**Note 1:** In 32-bit mode, the T3CON control bits do not affect 32-bit timer operation.



# PIC24F16KA102 FAMILY

## REGISTER 13-2: T3CON: TIMER3 CONTROL REGISTER

R/W-0	U-0	R/W-0	U-0	U-0	U-0	U-0	U-0
TON <sup>(1)</sup>	—	TSIDL <sup>(1)</sup>	—	—	—	—	—
bit 15						bit 8	

U-0	R/W-0	R/W-0	R/W-0	U-0	U-0	R/W-0	U-0
—	TGATE <sup>(1)</sup>	TCKPS1 <sup>(1)</sup>	TCKPS0 <sup>(1)</sup>	—	—	TCS <sup>(1)</sup>	—
bit 7						bit 0	

### Legend:

R = Readable bit                      W = Writable bit                      U = Unimplemented bit, read as '0'  
 -n = Value at POR                      '1' = Bit is set                      '0' = Bit is cleared                      x = Bit is unknown

- bit 15            **TON:** Timer3 On bit<sup>(1)</sup>  
                   1 = Starts 16-bit Timer3  
                   0 = Stops 16-bit Timer3
- bit 14            **Unimplemented:** Read as '0'
- bit 13            **TSIDL:** Stop in Idle Mode bit<sup>(1)</sup>  
                   1 = Discontinue module operation when device enters Idle mode  
                   0 = Continue module operation in Idle mode
- bit 12-7        **Unimplemented:** Read as '0'
- bit 6            **TGATE:** Timer3 Gated Time Accumulation Enable bit<sup>(1)</sup>  
                   When TCS = 1:  
                   This bit is ignored.  
                   When TCS = 0:  
                   1 = Gated time accumulation is enabled  
                   0 = Gated time accumulation is disabled
- bit 5-4        **TCKPS<1:0>:** Timer3 Input Clock Prescale Select bits<sup>(1)</sup>  
                   11 = 1:256  
                   10 = 1:64  
                   01 = 1:8  
                   00 = 1:1
- bit 3-2        **Unimplemented:** Read as '0'
- bit 1            **TCS:** Timer3 Clock Source Select bit<sup>(1)</sup>  
                   1 = External clock from the T3CK pin (on the rising edge)  
                   0 = Internal clock (F<sub>OSC</sub>/2)
- bit 0            **Unimplemented:** Read as '0'

**Note 1:** When 32-bit operation is enabled (T2CON<3> = 1), these bits have no effect on Timer3 operation; all timer functions are set through T2CON.

# PIC24F16KA102 FAMILY

---

NOTES:

# PIC24F16KA102 FAMILY

## 14.0 INPUT CAPTURE

**Note:** This data sheet summarizes the features of this group of PIC24F devices. It is not intended to be a comprehensive reference source. For more information on Input Capture, refer to the “PIC24F Family Reference Manual”, Section 15. “Input Capture” (DS39701).

The input capture module is used to capture a timer value from one of two selectable time bases upon an event on an input pin.

The input capture features are quite useful in applications requiring frequency (Time Period) and pulse measurement. Figure 14-1 depicts a simplified block diagram of the input capture module.

The PIC24F16KA102 family devices have one input capture channel. The input capture module has multiple operating modes, which are selected via the IC1CON register. The operating modes include:

- Capture timer value on every falling edge of input applied at the IC1 pin
- Capture timer value on every rising edge of input applied at the IC1 pin
- Capture timer value on every 4<sup>th</sup> rising edge of input applied at the IC1 pin
- Capture timer value on every 16<sup>th</sup> rising edge of input applied at the IC1 pin
- Capture timer value on every rising and every falling edge of input applied at the IC1 pin
- Device wake-up from capture pin during CPU Sleep and Idle modes

The input capture module has a four-level FIFO buffer. The number of capture events required to generate a CPU interrupt can be selected by the user.

**FIGURE 14-1: INPUT CAPTURE BLOCK DIAGRAM**



# PIC24F16KA102 FAMILY

## 14.1 Input Capture Registers

**REGISTER 14-1: IC1CON: INPUT CAPTURE 1 CONTROL REGISTER**

U-0	U-0	R/W-0	U-0	U-0	U-0	U-0	U-0
—	—	ICSIDL	—	—	—	—	—
bit 15						bit 8	

R/W-0	R/W-0	R/W-0	R-0, HC	R-0, HC	R/W-0	R/W-0	R/W-0
ICTMR	ICI1	ICI0	ICOV	ICBNE	ICM2	ICM1	ICM0
bit 7						bit 0	

<b>Legend:</b>	HC = Hardware Clearable bit		
R = Readable bit	W = Writable bit	U = Unimplemented bit, read as '0'	
-n = Value at POR	'1' = Bit is set	'0' = Bit is cleared	x = Bit is unknown

- bit 15-14     **Unimplemented:** Read as '0'
- bit 13       **ICSIDL:** Input Capture 1 Module Stop in Idle Control bit  
               1 = Input capture module will halt in CPU Idle mode  
               0 = Input capture module will continue to operate in CPU Idle mode
- bit 12-8     **Unimplemented:** Read as '0'
- bit 7         **ICTMR:** Input Capture 1 Timer Select bit  
               1 = TMR2 contents are captured on capture event  
               0 = TMR3 contents are captured on capture event
- bit 6-5      **ICI<1:0>:** Select Number of Captures per Interrupt bits  
               11 = Interrupt on every fourth capture event  
               10 = Interrupt on every third capture event  
               01 = Interrupt on every second capture event  
               00 = Interrupt on every capture event
- bit 4         **ICOV:** Input Capture 1 Overflow Status Flag bit (read-only)  
               1 = Input capture overflow occurred  
               0 = No input capture overflow occurred
- bit 3         **ICBNE:** Input Capture 1 Buffer Empty Status bit (read-only)  
               1 = Input capture buffer is not empty, at least one more capture value can be read  
               0 = Input capture buffer is empty
- bit 2-0      **ICM<2:0>:** Input Capture 1 Mode Select bits  
               111 = Input capture functions as interrupt pin only when device is in Sleep or Idle mode (rising edge detect only, all other control bits are not applicable)  
               110 = Unused (module is disabled)  
               101 = Capture mode, every 16th rising edge  
               100 = Capture mode, every 4th rising edge  
               011 = Capture mode, every rising edge  
               010 = Capture mode, every falling edge  
               001 = Capture mode, every edge (rising and falling) – ICI<1:0> bits do not control interrupt generation for this mode  
               000 = Input capture module is turned off

## 15.0 OUTPUT COMPARE

**Note:** This data sheet summarizes the features of this group of PIC24F devices. It is not intended to be a comprehensive reference source. For more information on Output Compare, refer to the “PIC24F Family Reference Manual”, **Section 16. “Output Compare”** (DS39706).

### 15.1 Setup for Single Output Pulse Generation

When the OCM control bits (OC1CON<2:0>) are set to ‘100’, the selected output compare channel initializes the OC1 pin to the low state and generates a single output pulse.

To generate a single output pulse, the following steps are required (these steps assume the timer source is initially turned off, but this is not a requirement for the module operation):

1. Determine the instruction clock cycle time. Take into account the frequency of the external clock to the timer source (if one is used) and the timer prescaler settings.
2. Calculate time to the rising edge of the output pulse relative to the TMRy start value (0000h).
3. Calculate the time to the falling edge of the pulse based on the desired pulse width and the time to the rising edge of the pulse.
4. Write the values computed in Steps 2 and 3 above into the Output Compare 1 register, OC1R, and the Output Compare 1 Secondary register, OC1RS, respectively.
5. Set Timer Period register, PRy, to value equal to or greater than the value in OC1RS, the Output Compare 1 Secondary register.
6. Set the OCM bits to ‘100’ and the OCTSEL (OC1CON<3>) bit to the desired timer source. The OC1 pin state will now be driven low.
7. Set the TON (TyCON<15>) bit to ‘1’, which enables the compare time base to count.
8. Upon the first match between TMRy and OC1R, the OC1 pin will be driven high.
9. When the incrementing timer, TMRy, matches the Output Compare 1 Secondary register, OC1RS, the second and trailing edge (high-to-low) of the pulse is driven onto the OC1 pin. No additional pulses are driven onto the OC1 pin and it remains low. As a result of the second compare match event, the OC1IF interrupt flag bit is set, which will result in an interrupt if it is enabled, by setting the OC1IE bit. For further information on peripheral interrupts, refer to [Section 8.0 “Interrupt Controller”](#).

10. To initiate another single pulse output, change the Timer and Compare register settings, if needed, and then issue a write to set the OCM bits to ‘100’. Disabling and re-enabling of the timer and clearing the TMRy register are not required, but may be advantageous for defining a pulse from a known event time boundary.

The output compare module does not have to be disabled after the falling edge of the output pulse. Another pulse can be initiated by rewriting the value of the OC1CON register.

### 15.2 Setup for Continuous Output Pulse Generation

When the OCM control bits (OC1CON<2:0>) are set to ‘101’, the selected output compare channel initializes the OC1 pin to the low state and generates output pulses on each and every compare match event.

For the user to configure the module for the generation of a continuous stream of output pulses, the following steps are required (these steps assume the timer source is initially turned off, but this is not a requirement for the module operation):

1. Determine the instruction clock cycle time. Take into account the frequency of the external clock to the timer source (if one is used) and the timer prescaler settings.
2. Calculate time to the rising edge of the output pulse relative to the TMRy start value (0000h).
3. Calculate the time to the falling edge of the pulse based on the desired pulse width and the time to the rising edge of the pulse.
4. Write the values computed in Step 2 and 3 above into the Output Compare 1 register, OC1R, and the Output Compare 1 Secondary register, OC1RS, respectively.
5. Set the Timer Period register, PRy, to a value equal to or greater than the value in OC1RS.
6. Set the OCM bits to ‘101’ and the OCTSEL bit to the desired timer source. The OC1 pin state will now be driven low.
7. Enable the compare time base by setting the TON (TyCON<15>) bit to ‘1’.
8. Upon the first match between TMRy and OC1R, the OC1 pin will be driven high.
9. When the compare time base, TMRy, matches the OC1RS, the second and trailing edge (high-to-low) of the pulse is driven onto the OC1 pin.
10. As a result of the second compare match event, the OC1IF interrupt flag bit is set.
11. When the compare time base and the value in its respective Timer Period register match, the TMRy register resets to 0x0000 and resumes counting.
12. Steps 8 through 11 are repeated and a continuous stream of pulses is generated indefinitely. The OC1IF flag is set on each OC1RS/TMRy compare match event.

# PIC24F16KA102 FAMILY

## 15.3 Pulse-Width Modulation (PWM) Mode

The following steps should be taken when configuring the output compare module for PWM operation:

1. Set the PWM period by writing to the selected Timer Period register (PRy).
2. Set the PWM duty cycle by writing to the OC1RS register.
3. Write the OC1R register with the initial duty cycle.
4. Enable interrupts, if required, for the timer and output compare modules. The output compare interrupt is required for PWM Fault pin utilization.
5. Configure the output compare module for one of two PWM Operation modes by writing to the Output Compare Mode bits, OCM<2:0> (OC1CON<2:0>).
6. Set the TMRy prescale value and enable the time base by setting TON (TxCON<15>) = 1.

**Note:** The OC1R register should be initialized before the output compare module is first enabled. The OC1R register becomes a read-only Duty Cycle register when the module is operated in the PWM modes. The value held in OC1R will become the PWM duty cycle for the first PWM period. The contents of the Output Compare 1 Secondary register, OC1RS, will not be transferred into OC1R until a time base period match occurs.

### 15.3.1 PWM PERIOD

The PWM period is specified by writing to PRy, the Timer Period register. The PWM period can be calculated using [Equation 15-1](#).

### EQUATION 15-1: CALCULATING THE PWM PERIOD<sup>(1)</sup>

$$\text{PWM Period} = [(PRy) + 1] \cdot T_{CY} \cdot (\text{Timer Prescale Value})$$

where:

$$\text{PWM Frequency} = 1/[\text{PWM Period}]$$

**Note 1:** Based on  $T_{CY} = 2 \cdot T_{OSC}$ ; Doze mode and PLL are disabled.

**Note:** A PRy value of N will produce a PWM period of N + 1 time base count cycles. For example, a value of 7, written into the PRy register, will yield a period consisting of 8 time base cycles.

### 15.3.2 PWM DUTY CYCLE

The PWM duty cycle is specified by writing to the OC1RS register. The OC1RS register can be written to at any time, but the duty cycle value is not latched into OC1R until a match between PRy and TMRy occurs (i.e., the period is complete). This provides a double buffer for the PWM duty cycle and is essential for glitchless PWM operation. In PWM mode, OC1R is a read-only register.

Some important boundary parameters of the PWM duty cycle include:

- If the Output Compare 1 register, OC1R, is loaded with 0000h, the OC1 pin will remain low (0% duty cycle).
- If OC1R is greater than PRy (Timer Period register), the pin will remain high (100% duty cycle).
- If OC1R is equal to PRy, the OC1 pin will be low for one time base count value and high for all other count values.

See [Example 15-1](#) for PWM mode timing details. [Table 15-1](#) provides an example of PWM frequencies and resolutions for a device operating at 10 MIPS.

### EQUATION 15-2: CALCULATION FOR MAXIMUM PWM RESOLUTION<sup>(1)</sup>

$$\text{Maximum PWM Resolution (bits)} = \frac{\log_{10}\left(\frac{F_{CY}}{F_{PWM} \cdot (\text{Timer Prescale Value})}\right)}{\log_{10}(2)} \text{ bits}$$

**Note 1:** Based on  $F_{CY} = F_{OSC}/2$ ; Doze mode and PLL are disabled.

# PIC24F16KA102 FAMILY

## EXAMPLE 15-1: PWM PERIOD AND DUTY CYCLE CALCULATIONS<sup>(1)</sup>

1. Find the Timer Period register value for a desired PWM frequency of 52.08 kHz, where  $F_{osc} = 8$  MHz with PLL (32 MHz device clock rate) and a Timer2 prescaler setting of 1:1.

$$T_{CY} = 2 * T_{osc} = 62.5 \text{ ns}$$

$$\text{PWM Period} = 1/\text{PWM Frequency} = 1/52.08 \text{ kHz} = 19.2 \text{ } \mu\text{s}$$

$$\text{PWM Period} = (\text{PR2} + 1) * T_{CY} * (\text{Timer 2 Prescale Value})$$

$$19.2 \text{ } \mu\text{s} = (\text{PR2} + 1) * 62.5 \text{ ns} * 1$$

$$\text{PR2} = 306$$

2. Find the maximum resolution of the duty cycle that can be used with a 52.08 kHz frequency and a 32 MHz device clock rate:

$$\text{PWM Resolution} = \log_{10}(F_{CY}/F_{PWM})/\log_{10}2 \text{ bits}$$

$$= (\log_{10}(16 \text{ MHz}/52.08 \text{ kHz})/\log_{10}2) \text{ bits}$$

$$= 8.3 \text{ bits}$$

**Note 1:** Based on  $T_{CY} = 2 * T_{osc}$ ; Doze mode and PLL are disabled.

**TABLE 15-1: EXAMPLE PWM FREQUENCIES AND RESOLUTIONS AT 4 MIPS ( $F_{CY} = 4$  MHz)<sup>(1)</sup>**

PWM Frequency	7.6 Hz	61 Hz	122 Hz	977 Hz	3.9 kHz	31.3 kHz	125 kHz
Timer Prescaler Ratio	8	1	1	1	1	1	1
Period Register Value	FFFFh	FFFFh	7FFFh	0FFFh	03FFh	007Fh	001Fh
Resolution (bits)	16	16	15	12	10	7	5

**Note 1:** Based on  $F_{CY} = F_{osc}/2$ ; Doze mode and PLL are disabled.

**TABLE 15-2: EXAMPLE PWM FREQUENCIES AND RESOLUTIONS AT 16 MIPS ( $F_{CY} = 16$  MHz)<sup>(1)</sup>**

PWM Frequency	30.5 Hz	244 Hz	488 Hz	3.9 kHz	15.6 kHz	125 kHz	500 kHz
Timer Prescaler Ratio	8	1	1	1	1	1	1
Period Register Value	FFFFh	FFFFh	7FFFh	0FFFh	03FFh	007Fh	001Fh
Resolution (bits)	16	16	15	12	10	7	5

**Note 1:** Based on  $F_{CY} = F_{osc}/2$ ; Doze mode and PLL are disabled.

# PIC24F16KA102 FAMILY

FIGURE 15-1: OUTPUT COMPARE MODULE BLOCK DIAGRAM





# PIC24F16KA102 FAMILY

## 15.4 Output Compare Register

**REGISTER 15-1: OC1CON: OUTPUT COMPARE 1 CONTROL REGISTER**

U-0	U-0	R/W-0	U-0	U-0	U-0	U-0	U-0
—	—	OCSIDL	—	—	—	—	—
bit 15						bit 8	

U-0	U-0	U-0	R-0, HC	R/W-0	R/W-0	R/W-0	R/W-0
—	—	—	OCFLT	OCTSEL	OCM2	OCM1	OCM0
bit 7						bit 0	

<b>Legend:</b>	HC = Hardware Clearable bit
R = Readable bit	W = Writable bit
-n = Value at POR	'1' = Bit is set
	'0' = Bit is cleared
	x = Bit is unknown

- bit 15-14    **Unimplemented:** Read as '0'
- bit 13      **OCSIDL:** Stop Output Compare 1 in Idle Mode Control bit
  - 1 = Output Compare 1 will halt in CPU Idle mode
  - 0 = Output Compare 1 will continue to operate in CPU Idle mode
- bit 12-5    **Unimplemented:** Read as '0'
- bit 4        **OCFLT:** PWM Fault Condition Status bit
  - 1 = PWM Fault condition has occurred (cleared in HW only)
  - 0 = No PWM Fault condition has occurred (this bit is only used when OCM<2:0> = 111)
- bit 3        **OCTSEL:** Output Compare 1 Timer Select bit
  - 1 = Timer3 is the clock source for Output Compare 1
  - 0 = Timer2 is the clock source for Output Compare 1
 Refer to the device data sheet for specific time bases available to the output compare module.
- bit 2-0     **OCM<2:0>:** Output Compare 1 Mode Select bits
  - 111 = PWM mode on OC1, Fault pin; OCF1 enabled<sup>(1)</sup>
  - 110 = PWM mode on OC1, Fault pin; OCF1 disabled<sup>(1)</sup>
  - 101 = Initialize OC1 pin low, generate continuous output pulses on OC1 pin
  - 100 = Initialize OC1 pin low, generate single output pulse on OC1 pin
  - 011 = Compare event toggles OC1 pin
  - 010 = Initialize OC1 pin high, compare event forces OC1 pin low
  - 001 = Initialize OC1 pin low, compare event forces OC1 pin high
  - 000 = Output compare channel is disabled

**Note 1:** The OCFA pin controls the OC1 channel.

# PIC24F16KA102 FAMILY

## REGISTER 15-2: PADCFG1: PAD CONFIGURATION CONTROL REGISTER

U-0	U-0	U-0	U-0	U-0	U-0	U-0	U-0
—	—	—	—	—	—	—	—
bit 15							bit 8

U-0	U-0	U-0	R/W-0	R/W-0	R/W-0	R/W-0	R/W-0
—	—	—	SMBUSDEL <sup>(3)</sup>	OC1TRIS <sup>(2)</sup>	RTSECSEL1 <sup>(1,4)</sup>	RTSECSEL0 <sup>(1,4)</sup>	—
bit 7							bit 0

### Legend:

R = Readable bit      W = Writable bit      U = Unimplemented bit, read as '0'  
 -n = Value at POR      '1' = Bit is set      '0' = Bit is cleared      x = Bit is unknown

bit 15-5      **Unimplemented:** Read as '0'

bit 3      **OC1TRIS:** OC1 Output Tri-State Select bit<sup>(2)</sup>

1 = OC1 output will not be active on the pin; OCPWM1 can still be used for internal triggers  
 0 = OC1 output will be active on the pin based on the OCPWM1 module settings

bit 0      **Unimplemented:** Read as '0'

**Note 1:** To enable the actual RTCC output, the RTCOE (RCFGCAL) bit needs to be set.

**Note 2:** To enable the actual OC1 output, the OCPWM1 module has to be enabled.

**Note 3:** Bit 4 is described in [Section 17.0 "Inter-Integrated Circuit \(I2C™\)"](#).

**Note 4:** Bits 2 and 1 are described in [Section 19.0 Real-Time Clock and Calendar \(RTCC\)](#).

## 16.0 SERIAL PERIPHERAL INTERFACE (SPI)

**Note:** This data sheet summarizes the features of this group of PIC24F devices. It is not intended to be a comprehensive reference source. For more information on the Serial Peripheral Interface, refer to the “PIC24F Family Reference Manual”, Section 23. “Serial Peripheral Interface (SPI)” (DS39699).

The Serial Peripheral Interface (SPI) module is a synchronous serial interface useful for communicating with other peripheral or microcontroller devices. These peripheral devices may be serial data EEPROMs, shift registers, display drivers, A/D Converters, etc. The SPI module is compatible with the SPI and SIOP interfaces from Motorola®.

The module supports operation in two buffer modes. In Standard mode, data is shifted through a single serial buffer. In Enhanced Buffer mode, data is shifted through an 8-level FIFO buffer.

**Note:** Do not perform read-modify-write operations (such as bit-oriented instructions) on the SPI1BUF register in either Standard or Enhanced Buffer mode.

The module also supports a basic framed SPI protocol while operating in either Master or Slave mode. A total of four framed SPI configurations are supported.

The SPI serial interface consists of four pins:

- SDI1: Serial Data Input
- SDO1: Serial Data Output
- SCK1: Shift Clock Input or Output
- $\overline{SS1}$ : Active-Low Slave Select or Frame Synchronization I/O Pulse

The SPI module can be configured to operate using 2, 3 or 4 pins. In the 3-pin mode,  $\overline{SS1}$  is not used. In the 2-pin mode, both SDO1 and  $\overline{SS1}$  are not used.

Block diagrams of the module in Standard and Enhanced Buffer modes are displayed in [Figure 16-1](#) and [Figure 16-2](#).

The devices of the PIC24F16KA102 family offer one SPI module on a device.

**Note:** In this section, the SPI module is referred to as SPI1, or separately as SPI1. Special Function Registers (SFRs) will follow a similar notation. For example, SPI1CON1 or SPI1CON2 refers to the control register for the SPI1 module.

To set up the SPI module for the Standard Master mode of operation:

1. If using interrupts:
  - a) Clear the respective SPI1IF bit in the IFS0 register.
  - b) Set the respective SPI1IE bit in the IEC0 register.
  - c) Write the respective SPI1IPx bits in the IPC2 register to set the interrupt priority.
2. Write the desired settings to the SPI1CON1 and SPI1CON2 registers with the MSTEN bit (SPI1CON1<5>) = 1.
3. Clear the SPIROV bit (SPI1STAT<6>).
4. Enable SPI operation by setting the SPIEN bit (SPI1STAT<15>).
5. Write the data to be transmitted to the SPI1BUF register. Transmission (and reception) will start as soon as data is written to the SPI1BUF register.

To set up the SPI module for the Standard Slave mode of operation:

1. Clear the SPI1BUF register.
2. If using interrupts:
  - a) Clear the respective SPI1IF bit in the IFS0 register.
  - b) Set the respective SPI1IE bit in the IEC0 register.
  - c) Write the respective SPI1IP bits in the IPC2 register to set the interrupt priority.
3. Write the desired settings to the SPI1CON1 and SPI1CON2 registers with the MSTEN bit (SPI1CON1<5>) = 0.
4. Clear the SMP bit.
5. If the CKE bit is set, then the SSEN bit (SPI1CON1<7>) must be set to enable the  $\overline{SS1}$  pin.
6. Clear the SPIROV bit (SPI1STAT<6>).
7. Enable SPI operation by setting the SPIEN bit (SPI1STAT<15>).

# PIC24F16KA102 FAMILY

FIGURE 16-1: SPI1 MODULE BLOCK DIAGRAM (STANDARD BUFFER MODE)



# PIC24F16KA102 FAMILY

To set up the SPI module for the Enhanced Buffer Master (EBM) mode of operation:

1. If using interrupts:
  - a) Clear the respective SPI1IF bit in the IFS0 register.
  - b) Set the respective SPI1IE bit in the IEC0 register.
  - c) Write the respective SPI1IPx bits in the IPC2 register.
2. Write the desired settings to the SPI1CON1 and SPI1CON2 registers with the MSTEN bit (SPI1CON1<5>) = 1.
3. Clear the SPIROV bit (SPI1STAT<6>).
4. Select Enhanced Buffer mode by setting the SPIBEN bit (SPI1CON2<0>).
5. Enable SPI operation by setting the SPIEN bit (SPI1STAT<15>).
6. Write the data to be transmitted to the SPI1BUF register. Transmission (and reception) will start as soon as data is written to the SPI1BUF register.

To set up the SPI module for the Enhanced Buffer Slave mode of operation:

1. Clear the SPI1BUF register.
2. If using interrupts:
  - a) Clear the respective SPI1IF bit in the IFS0 register.
  - b) Set the respective SPI1IE bit in the IEC0 register.
  - c) Write the respective SPI1IPx bits in the IPC2 register to set the interrupt priority.
3. Write the desired settings to the SPI1CON1 and SPI1CON2 registers with the MSTEN bit (SPI1CON1<5>) = 0.
4. Clear the SMP bit.
5. If the CKE bit is set, then the SSEN bit must be set, thus enabling the SS1 pin.
6. Clear the SPIROV bit (SPI1STAT<6>).
7. Select Enhanced Buffer mode by setting the SPIBEN bit (SPI1CON2<0>).
8. Enable SPI operation by setting the SPIEN bit (SPI1STAT<15>).

**FIGURE 16-2: SPI1 MODULE BLOCK DIAGRAM (ENHANCED BUFFER MODE)**

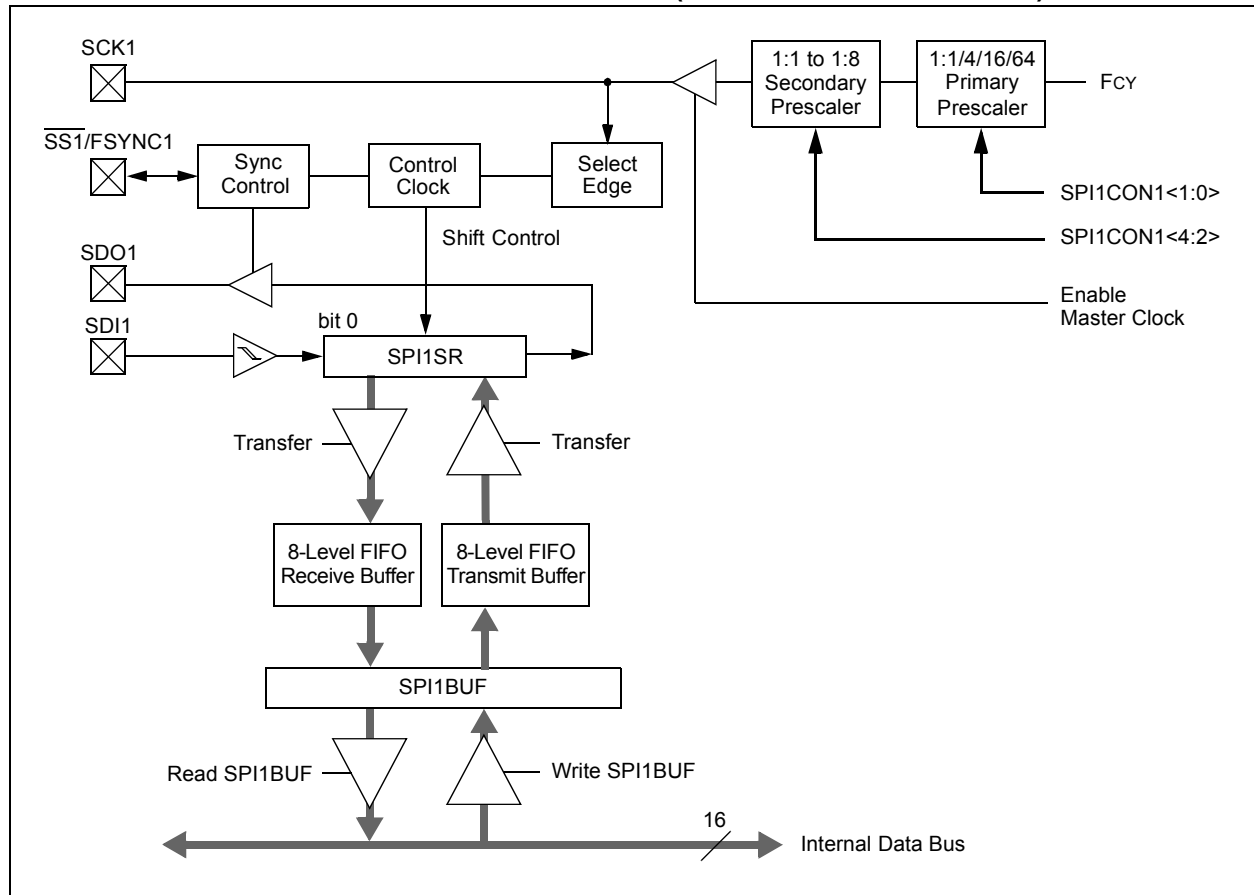

# PIC24F16KA102 FAMILY

## REGISTER 16-1: SPI1STAT: SPI1 STATUS AND CONTROL REGISTER

R/W-0	U-0	R/W-0	U-0	U-0	R-0, HSC	R-0, HSC	R-0, HSC
SPIEN	—	SPISIDL	—	—	SPIBEC2	SPIBEC1	SPIBEC0
bit 15						bit 8	

R-0,HSC	R/C-0, HS	R/W-0, HSC	R/W-0	R/W-0	R/W-0	R-0, HSC	R-0, HSC
SRMPT	SPIROV	SRXMPT	SISEL2	SISEL1	SISEL0	SPITBF	SPIRBF
bit 7						bit 0	

<b>Legend:</b>	U = Unimplemented bit, read as '0'	HSC = Hardware Settable/Clearable bit
R = Readable bit	W = Writable bit	H = Hardware Settable bit
-n = Value at POR	'1' = Bit is set	'0' = Bit is cleared
		x = Bit is unknown

- bit 15 **SPIEN:** SPI1 Enable bit  
 1 = Enables module and configures SCK1, SDO1, SDI1 and  $\overline{SS1}$  as serial port pins  
 0 = Disables module
- bit 14 **Unimplemented:** Read as '0'
- bit 13 **SPISIDL:** Stop in Idle Mode bit  
 1 = Discontinues module operation when device enters Idle mode  
 0 = Continues module operation in Idle mode
- bit 12-11 **Unimplemented:** Read as '0'
- bit 10-8 **SPIBEC<2:0>:** SPI1 Buffer Element Count bits (valid in Enhanced Buffer mode)  
Master mode:  
 Number of SPI transfers are pending.  
Slave mode:  
 Number of SPI transfers are unread.
- bit 7 **SRMPT:** Shift Register (SPI1SR) Empty bit (valid in Enhanced Buffer mode)  
 1 = SPI1 Shift register is empty and ready to send or receive  
 0 = SPI1 Shift register is not empty
- bit 6 **SPIROV:** Receive Overflow Flag bit  
 1 = A new byte/word is completely received and discarded  
 The user software has not read the previous data in the SPI1BUF register.  
 0 = No overflow has occurred
- bit 5 **SRXMPT:** Receive FIFO Empty bit (valid in Enhanced Buffer mode)  
 1 = Receive FIFO is empty  
 0 = Receive FIFO is not empty
- bit 4-2 **SISEL<2:0>:** SPI1 Buffer Interrupt Mode bits (valid in Enhanced Buffer mode)  
 111 = Interrupt when the SPI1 transmit buffer is full (SPITBF bit is set)  
 110 = Interrupt when the last bit is shifted into SPI1SR; as a result, the TX FIFO is empty  
 101 = Interrupt when the last bit is shifted out of SPI1SR; now the transmit is complete  
 100 = Interrupt when one data byte is shifted into the SPI1SR; as a result, the TX FIFO has one open spot  
 011 = Interrupt when the SPI1 receive buffer is full (SPIRBF bit set)  
 010 = Interrupt when the SPI1 receive buffer is 3/4 or more full  
 001 = Interrupt when data is available in receive buffer (SRMPT bit is set)  
 000 = Interrupt when the last data in the receive buffer is read; as a result, the buffer is empty  
 (SRXMPT bit is set)

# PIC24F16KA102 FAMILY

---

## REGISTER 16-1: SPI1STAT: SPI1 STATUS AND CONTROL REGISTER (CONTINUED)

- bit 1      **SPITBF:** SPI1 Transmit Buffer Full Status bit  
1 = Transmit has not yet started, SPI1TXB is full  
0 = Transmit has started, SPI1TXB is empty  
In Standard Buffer mode:  
Automatically set in hardware when the CPU writes to the SPITBF location, loading SPITBF.  
Automatically cleared in hardware when the SPI1 module transfers data from SPI1TXB to SPIRBF.  
In Enhanced Buffer mode:  
Automatically set in hardware when CPU writes to the SPI1BUF location, loading the last available buffer location.  
Automatically cleared in hardware when a buffer location is available for a CPU write.
- bit 0      **SPIRBF:** SPI1 Receive Buffer Full Status bit  
1 = Receive is complete; SPI1RXB is full  
0 = Receive is not complete; SPI1RXB is empty  
In Standard Buffer mode:  
Automatically set in hardware when SPI1 transfers data from SPIRBF to SPIRBF.  
Automatically cleared in hardware when the core reads the SPI1BUF location, reading SPIRBF.  
In Enhanced Buffer mode:  
Automatically set in hardware when SPI1 transfers data from SPI1SR to buffer, filling the last unread buffer location.  
Automatically cleared in hardware when a buffer location is available for a transfer from SPI1SR.

# PIC24F16KA102 FAMILY

**REGISTER 16-2: SPI1CON1: SPI CONTROL REGISTER 1**

U-0	U-0	U-0	R/W-0	R/W-0	R/W-0	R/W-0	R/W-0
—	—	—	DISSCK	DISSDO	MODE16	SMP	CKE <sup>(1)</sup>
bit 15						bit 8	

R/W-0	R/W-0	R/W-0	R/W-0	R/W-0	R/W-0	R/W-0	R/W-0
SSEN	CKP	MSTEN	SPRE2	SPRE1	SPRE0	PPRE1	PPRE0
bit 7						bit 0	

**Legend:**

R = Readable bit	W = Writable bit	U = Unimplemented bit, read as '0'
-n = Value at POR	'1' = Bit is set	'0' = Bit is cleared
		x = Bit is unknown

- bit 15-13     **Unimplemented:** Read as '0'
- bit 12       **DISSCK:** Disable SCK1 pin bit (SPI Master modes only)
  - 1 = Internal SPI clock is disabled, pin functions as I/O
  - 0 = Internal SPI clock is enabled
- bit 11       **DISSDO:** Disables SDO1 pin bit
  - 1 = SDO1 pin is not used by module; pin functions as I/O
  - 0 = SDO1 pin is controlled by the module
- bit 10       **MODE16:** Word/Byte Communication Select bit
  - 1 = Communication is word-wide (16 bits)
  - 0 = Communication is byte-wide (8 bits)
- bit 9        **SMP:** SPI1 Data Input Sample Phase bit
  - Master mode:
  - 1 = Input data is sampled at the end of data output time
  - 0 = Input data is sampled at the middle of data output time
  - Slave mode:
  - SMP must be cleared when SPI1 is used in Slave mode.
- bit 8        **CKE:** SPI1 Clock Edge Select bit<sup>(1)</sup>
  - 1 = Serial output data changes on transition from active clock state to Idle clock state (see bit 6)
  - 0 = Serial output data changes on transition from Idle clock state to active clock state (see bit 6)
- bit 7        **SSEN:** Slave Select Enable bit (Slave mode)
  - 1 =  $\overline{SS1}$  pin is used for Slave mode
  - 0 =  $\overline{SS1}$  pin is not used by the module; pin is controlled by port function
- bit 6        **CKP:** Clock Polarity Select bit
  - 1 = Idle state for clock is a high level; active state is a low level
  - 0 = Idle state for clock is a low level; active state is a high level
- bit 5        **MSTEN:** Master Mode Enable bit
  - 1 = Master mode
  - 0 = Slave mode
- bit 4-2      **SPRE<2:0>:** Secondary Prescale bits (Master mode)
  - 111 = Secondary prescale 1:1
  - 110 = Secondary prescale 2:1
  - .
  - .
  - .
  - 000 = Secondary prescale 8:1

**Note 1:** The CKE bit is not used in the Framed SPI modes. The user should program this bit to '0' for the Framed SPI modes (FRMEN = 1).



# PIC24F16KA102 FAMILY

## REGISTER 16-2: SPI1CON1: SPI1 CONTROL REGISTER 1 (CONTINUED)

bit 1-0 **PPRE<1:0>**: Primary Prescale bits (Master mode)  
 11 = Primary prescale 1:1  
 10 = Primary prescale 4:1  
 01 = Primary prescale 16:1  
 00 = Primary prescale 64:1

**Note 1:** The CKE bit is not used in the Framed SPI modes. The user should program this bit to '0' for the Framed SPI modes (FRMEN = 1).

## REGISTER 16-3: SPI1CON2: SPI1 CONTROL REGISTER 2

R/W-0	R/W-0	R/W-0	U-0	U-0	U-0	U-0	U-0
FRMEN	SPIFSD	SPIFPOL	—	—	—	—	—
bit 15						bit 8	

U-0	U-0	U-0	U-0	U-0	U-0	R/W-0	R/W-0
—	—	—	—	—	—	SPIFE	SPIBEN
bit 7						bit 0	

### Legend:

R = Readable bit                      W = Writable bit                      U = Unimplemented bit, read as '0'  
 -n = Value at POR                      '1' = Bit is set                      '0' = Bit is cleared                      x = Bit is unknown

bit 15 **FRMEN**: Framed SPI1 Support bit  
 1 = Framed SPI1 support is enabled  
 0 = Framed SPI1 support is disabled

bit 14 **SPIFSD**: Frame Sync Pulse Direction Control on  $\overline{SS1}$  Pin bit  
 1 = Frame sync pulse input (slave)  
 0 = Frame sync pulse output (master)

bit 13 **SPIFPOL**: Frame Sync Pulse Polarity bit (Frame mode only)  
 1 = Frame sync pulse is active-high  
 0 = Frame sync pulse is active-low

bit 12-2 **Unimplemented**: Read as '0'

bit 1 **SPIFE**: Frame Sync Pulse Edge Select bit  
 1 = Frame sync pulse coincides with the first bit clock  
 0 = Frame sync pulse precedes the first bit clock

bit 0 **SPIBEN**: Enhanced Buffer Enable bit  
 1 = Enhanced Buffer is enabled  
 0 = Enhanced Buffer is disabled (Legacy mode)

# PIC24F16KA102 FAMILY

**EQUATION 16-1: RELATIONSHIP BETWEEN DEVICE AND SPI CLOCK SPEED<sup>(1)</sup>**

$$F_{SCK} = \frac{F_{CY}}{\text{Primary Prescaler} * \text{Secondary Prescaler}}$$

**Note 1:** Based on  $F_{CY} = F_{OSC}/2$ ; Doze mode and PLL are disabled.

**TABLE 16-1: SAMPLE SCK FREQUENCIES<sup>(1,2)</sup>**

F <sub>CY</sub> = 16 MHz		Secondary Prescaler Settings				
		1:1	2:1	4:1	6:1	8:1
Primary Prescaler Settings	1:1	Invalid	8000	4000	2667	2000
	4:1	4000	2000	1000	667	500
	16:1	1000	500	250	167	125
	64:1	250	125	63	42	31
F <sub>CY</sub> = 5 MHz						
Primary Prescaler Settings	1:1	5000	2500	1250	833	625
	4:1	1250	625	313	208	156
	16:1	313	156	78	52	39
	64:1	78	39	20	13	10

**Note 1:** Based on  $F_{CY} = F_{OSC}/2$ ; Doze mode and PLL are disabled.

**2:** SCK1 frequencies are indicated in kHz.

## 17.0 INTER-INTEGRATED CIRCUIT (I<sup>2</sup>C™)

**Note:** This data sheet summarizes the features of this group of PIC24F devices. It is not intended to be a comprehensive reference source. For more information on the Inter-Integrated Circuit, refer to the “PIC24F Family Reference Manual”, Section 24. “Inter-Integrated Circuit™ (I<sup>2</sup>C™)” (DS39702).

The Inter-Integrated Circuit (I<sup>2</sup>C) module is a serial interface useful for communicating with other peripheral or microcontroller devices. These peripheral devices may be serial data EEPROMs, display drivers, A/D Converters, etc.

The I<sup>2</sup>C module supports these features:

- Independent master and slave logic
- 7-bit and 10-bit device addresses
- General call address, as defined in the I<sup>2</sup>C protocol
- Automatic clock stretching to provide delays for the processor to respond to a slave data request
- Both 100 kHz and 400 kHz bus specifications
- Configurable address masking
- Multi-Master modes to prevent loss of messages in arbitration
- Bus Repeater mode, allowing the acceptance of all messages as a slave regardless of the address
- Automatic SCL

Figure 17-1 illustrates a block diagram of the module.

### 17.1 Pin Remapping Options

The I<sup>2</sup>C module is tied to a fixed pin. To allow flexibility with peripheral multiplexing, the I2C1 module in 28-pin devices can be reassigned to the alternate pins, designated as SCL1 and SDA1 during device configuration.

Pin assignment is controlled by the I2C1SEL Configuration bit. Programming this bit (= 0) multiplexes the module to the SCL1 and SDA1 pins.

## 17.2 Communicating as a Master in a Single Master Environment

The details of sending a message in Master mode depends on the communications protocol for the device being communicated with. Typically, the sequence of events is as follows:

1. Assert a Start condition on SDA1 and SCL1.
2. Send the I<sup>2</sup>C device address byte to the slave with a write indication.
3. Wait for and verify an Acknowledge from the slave.
4. Send the first data byte (sometimes known as the command) to the slave.
5. Wait for and verify an Acknowledge from the slave.
6. Send the serial memory address low byte to the slave.
7. Repeat Steps 4 and 5 until all data bytes are sent.
8. Assert a Repeated Start condition on SDA1 and SCL1.
9. Send the device address byte to the slave with a read indication.
10. Wait for and verify an Acknowledge from the slave.
11. Enable master reception to receive serial memory data.
12. Generate an ACK or NACK condition at the end of a received byte of data.
13. Generate a Stop condition on SDA1 and SCL1.

# PIC24F16KA102 FAMILY

FIGURE 17-1: I<sup>2</sup>C™ BLOCK DIAGRAM



# PIC24F16KA102 FAMILY

## 17.3 Setting Baud Rate When Operating as a Bus Master

To compute the Baud Rate Generator (BRG) reload value, use Equation 17-1.

**EQUATION 17-1: COMPUTING BAUD RATE RELOAD VALUE<sup>(1)</sup>**

$$F_{SCL} = \frac{F_{CY}}{I2C1BRG + 1 + \frac{F_{CY}}{10,000,000}}$$

or

$$I2C1BRG = \left( \frac{F_{CY}}{F_{SCL}} - \frac{F_{CY}}{10,000,000} \right) - 1$$

**Note 1:** Based on  $F_{CY} = F_{OSC}/2$ ; Doze mode and PLL are disabled.

## 17.4 Slave Address Masking

The I2C1MSK register (Register 17-3) designates address bit positions as “don’t care” for both 7-Bit and 10-Bit Addressing modes. Setting a particular bit location (= 1) in the I2C1MSK register causes the slave module to respond whether the corresponding address bit value is ‘0’ or ‘1’. For example, when I2C1MSK is set to ‘00100000’, the slave module will detect both addresses: ‘00000000’ and ‘00100000’.

To enable address masking, the Intelligent Peripheral Management Interface (IPMI) must be disabled by clearing the IPMIEN bit (I2C1CON<11>).

**Note:** As a result of changes in the I<sup>2</sup>C protocol, the addresses in Table 17-2 are reserved and will not be Acknowledged in Slave mode. This includes any address mask settings that include any of these addresses.

**TABLE 17-1: I<sup>2</sup>C™ CLOCK RATES<sup>(1)</sup>**

Required System F <sub>SCL</sub>	F <sub>CY</sub>	I2C1BRG Value		Actual F <sub>SCL</sub>
		(Decimal)	(Hexadecimal)	
100 kHz	16 MHz	157	9D	100 kHz
100 kHz	8 MHz	78	4E	100 kHz
100 kHz	4 MHz	39	27	99 kHz
400 kHz	16 MHz	37	25	404 kHz
400 kHz	8 MHz	18	12	404 kHz
400 kHz	4 MHz	9	9	385 kHz
400 kHz	2 MHz	4	4	385 kHz
1 MHz	16 MHz	13	D	1.026 MHz
1 MHz	8 MHz	6	6	1.026 MHz
1 MHz	4 MHz	3	3	0.909 MHz

**Note 1:** Based on  $F_{CY} = F_{OSC}/2$ ; Doze mode and PLL are disabled;

**TABLE 17-2: I<sup>2</sup>C™ RESERVED ADDRESSES<sup>(1)</sup>**

Slave Address	R/W Bit	Description
0000 000	0	General Call Address <sup>(2)</sup>
0000 000	1	Start Byte
0000 001	x	Cbus Address
0000 010	x	Reserved
0000 011	x	Reserved
0000 1xx	x	HS Mode Master Code
1111 1xx	x	Reserved
1111 0xx	x	10-Bit Slave Upper Byte <sup>(3)</sup>

**Note 1:** The address bits listed here will never cause an address match, independent of the address mask settings.

**2:** The address will be Acknowledged only if GCEN = 1.

**3:** A match on this address can only occur on the upper byte in 10-Bit Addressing mode.

# PIC24F16KA102 FAMILY

## REGISTER 17-1: I2C1CON: I2C1 CONTROL REGISTER

R/W-0	U-0	R/W-0	R/W-1 HC	R/W-0	R/W-0	R/W-0	R/W-0
I2CEN	—	I2CSIDL	SCLREL	IPMIEN	A10M	DISSLW	SMEN
bit 15							bit 8

R/W-0	R/W-0	R/W-0	R/W-0, HC	R/W-0, HC	R/W-0, HC	R/W-0, HC	R/W-0, HC
GCEN	STREN	ACKDT	ACKEN	RCEN	PEN	RSEN	SEN
bit 7							bit 0

<b>Legend:</b>	HC = Hardware Clearable bit
R = Readable bit	W = Writable bit
-n = Value at POR	'1' = Bit is set
	U = Unimplemented bit, read as '0'
	'0' = Bit is cleared
	x = Bit is unknown

- bit 15     **I2CEN:** I2C1 Enable bit  
1 = Enables the I2C1 module and configures the SDA1 and SCL1 pins as serial port pins  
0 = Disables the I2C1 module; all I<sup>2</sup>C™ pins are controlled by port functions
- bit 14     **Unimplemented:** Read as '0'
- bit 13     **I2CSIDL:** Stop in Idle Mode bit  
1 = Discontinues module operation when device enters an Idle mode  
0 = Continues module operation in Idle mode
- bit 12     **SCLREL:** SCL1 Release Control bit (when operating as I<sup>2</sup>C slave)  
1 = Releases SCL1 clock  
0 = Holds SCL1 clock low (clock stretch)  
**If STREN = 1:**  
Bit is R/W (i.e., software may write '0' to initiate stretch and write '1' to release clock). Hardware is clear at the beginning of slave transmission; hardware is clear at the end of slave reception.  
**If STREN = 0:**  
Bit is R/S (i.e., software may only write '1' to release clock). Hardware is clear at the beginning of slave transmission.
- bit 11     **IPMIEN:** Intelligent Peripheral Management Interface (IPMI) Enable bit  
1 = IPMI Support mode is enabled; all addresses are Acknowledged  
0 = IPMI Support mode is disabled
- bit 10     **A10M:** 10-Bit Slave Addressing bit  
1 = I2C1ADD is a 10-bit slave address  
0 = I2C1ADD is a 7-bit slave address
- bit 9      **DISSLW:** Disable Slew Rate Control bit  
1 = Slew rate control is disabled  
0 = Slew rate control is enabled
- bit 8      **SMEN:** SMBus Input Levels bit  
1 = Enables I/O pin thresholds compliant with the SMBus specification  
0 = Disables the SMBus input thresholds
- bit 7      **GCEN:** General Call Enable bit (when operating as I<sup>2</sup>C slave)  
1 = Enables interrupt when a general call address is received in the I2C1RSR (module is enabled for reception)  
0 = General call address is disabled
- bit 6      **STREN:** SCL1 Clock Stretch Enable bit (when operating as I<sup>2</sup>C slave)  
Used in conjunction with the SCLREL bit.  
1 = Enables software or receive clock stretching  
0 = Disables software or receive clock stretching

# PIC24F16KA102 FAMILY

---

## REGISTER 17-1: I2C1CON: I2C1 CONTROL REGISTER (CONTINUED)

- bit 5      **ACKDT:** Acknowledge Data bit (when operating as I<sup>2</sup>C master; applicable during master receive)  
Value that will be transmitted when the software initiates an Acknowledge sequence.  
1 = Sends NACK during Acknowledge  
0 = Sends ACK during Acknowledge
- bit 4      **ACKEN:** Acknowledge Sequence Enable bit  
(when operating as I<sup>2</sup>C master; applicable during master receive)  
1 = Initiates Acknowledge sequence on SDA1 and SCL1 pins and transmits ACKDT data bit; hardware is clear at the end of the master Acknowledge sequence  
0 = Acknowledge sequence is not in progress
- bit 3      **RCEN:** Receive Enable bit (when operating as I<sup>2</sup>C master)  
1 = Enables Receive mode for I<sup>2</sup>C; hardware is clear at the end of eighth bit of master receive data byte  
0 = Receive sequence not in progress
- bit 2      **PEN:** Stop Condition Enable bit (when operating as I<sup>2</sup>C master)  
1 = Initiates Stop condition on SDA1 and SCL1 pins; hardware is clear at end of master Stop sequence  
0 = Stop condition is not in progress
- bit 1      **RSEN:** Repeated Start Condition Enable bit (when operating as I<sup>2</sup>C master)  
1 = Initiates Repeated Start condition on SDA1 and SCL1 pins; hardware is clear at end of master Repeated Start sequence  
0 = Repeated Start condition is not in progress
- bit 0      **SEN:** Start Condition Enable bit (when operating as I<sup>2</sup>C master)  
1 = Initiates Start condition on SDA1 and SCL1 pins; hardware is clear at end of master Start sequence  
0 = Start condition is not in progress

# PIC24F16KA102 FAMILY

## REGISTER 17-2: I2C1STAT: I2C1 STATUS REGISTER

R-0, HSC	R-0, HSC	U-0	U-0	U-0	R/C-0, HS	R-0, HSC	R-0, HSC
ACKSTAT	TRSTAT	—	—	—	BCL	GCSTAT	ADD10
bit 15							bit 8

R/C-0, HS	R/C-0, HS	R-0, HSC	R/C-0, HSC	R/C-0, HSC	R-0, HSC	R-0, HSC	R-0, HSC
IWCOL	I2COV	D/A	P	S	R/W	RBF	TBF
bit 7							bit 0

<b>Legend:</b>	C = Clearable bit	HS = Hardware Settable bit	HSC = Hardware Settable/Clearable bit
R = Readable bit	W = Writable bit	U = Unimplemented bit, read as '0'	
-n = Value at POR	'1' = Bit is set	'0' = Bit is cleared	x = Bit is unknown

- bit 15     **ACKSTAT:** Acknowledge Status bit  
1 = NACK was detected last  
0 = ACK was detected last  
Hardware is set or clear at of Acknowledge.
- bit 14     **TRSTAT:** Transmit Status bit  
(When operating as I<sup>2</sup>C™ master; applicable to master transmit operation.)  
1 = Master transmit is in progress (8 bits + ACK)  
0 = Master transmit is not in progress  
Hardware is set at beginning of master transmission; hardware is clear at end of slave Acknowledge.
- bit 13-11   **Unimplemented:** Read as '0'
- bit 10     **BCL:** Master Bus Collision Detect bit  
1 = A bus collision has been detected during a master operation  
0 = No collision  
Hardware is set at detection of bus collision.
- bit 9     **GCSTAT:** General Call Status bit  
1 = General call address was received  
0 = General call address was not received  
Hardware is set when address matches general call address; hardware is clear at Stop detection.
- bit 8     **ADD10:** 10-Bit Address Status bit  
1 = 10-bit address was matched  
0 = 10-bit address was not matched  
Hardware is set at match of 2<sup>nd</sup> byte of matched 10-bit address; hardware is clear at Stop detection.
- bit 7     **IWCOL:** Write Collision Detect bit  
1 = An attempt to write to the I2C1TRN register failed because the I<sup>2</sup>C module is busy  
0 = No collision  
Hardware is set at occurrence of write to I2C1TRN while busy (cleared by software).
- bit 6     **I2COV:** Receive Overflow Flag bit  
1 = A byte was received while the I2C1RCV register is still holding the previous byte  
0 = No overflow  
Hardware is set at attempt to transfer to I2C1RCV (cleared by software).
- bit 5     **D/A:** Data/Address bit (when operating as I<sup>2</sup>C slave)  
1 = Indicates that the last byte received was data  
0 = Indicates that the last byte received was the device address  
Hardware is clear at device address match; hardware is set by a write to I2C1TRN or by reception of slave byte.
- bit 4     **P:** Stop bit  
1 = Indicates that a Stop bit has been detected last  
0 = Stop bit was not detected last  
Hardware is set or clear when Start, Repeated Start or Stop is detected.



# PIC24F16KA102 FAMILY

---

## REGISTER 17-2: I2C1STAT: I2C1 STATUS REGISTER (CONTINUED)

- bit 3     **S:** Start bit  
1 = Indicates that a Start (or Repeated Start) bit has been detected last  
0 = Start bit was not detected last  
Hardware is set or clear when Start, Repeated Start or Stop is detected.
- bit 2     **R/W:** Read/Write Information bit (when operating as I<sup>2</sup>C slave)  
1 = Read – indicates the data transfer is output from slave  
0 = Write – indicates the data transfer is input to slave  
Hardware is set or clear after reception of I<sup>2</sup>C device address byte.
- bit 1     **RBF:** Receive Buffer Full Status bit  
1 = Receive complete, I2C1RCV is full  
0 = Receive not complete, I2C1RCV is empty  
Hardware is set when I2C1RCV is written with received byte; hardware is clear when software reads I2C1RCV.
- bit 0     **TBF:** Transmit Buffer Full Status bit  
1 = Transmit in progress, I2C1TRN is full  
0 = Transmit complete, I2C1TRN is empty  
Hardware is set when software writes to I2C1TRN; hardware is clear at completion of data transmission.

# PIC24F16KA102 FAMILY

## REGISTER 17-3: I2C1MSK: I2C1 SLAVE MODE ADDRESS MASK REGISTER

U-0	U-0	U-0	U-0	U-0	U-0	R/W-0	R/W-0
—	—	—	—	—	—	AMSK9	AMSK8
bit 15						bit 8	

R/W-0	R/W-0	R/W-0	R/W-0	R/W-0	R/W-0	R/W-0	R/W-0
AMSK7	AMSK6	AMSK5	AMSK4	AMSK3	AMSK2	AMSK1	AMSK0
bit 7							bit 0

### Legend:

R = Readable bit      W = Writable bit      U = Unimplemented bit, read as '0'  
 -n = Value at POR      '1' = Bit is set      '0' = Bit is cleared      x = Bit is unknown

bit 15-10      **Unimplemented:** Read as '0'

bit 9-0      **AMSK<9:0>:** Mask for Address Bit x Select bits

1 = Enable masking for bit x of incoming message address; bit match is not required in this position  
 0 = Disable masking for bit x; bit match is required in this position

## REGISTER 17-4: PADCFG1: PAD CONFIGURATION CONTROL REGISTER

U-0	U-0	U-0	U-0	U-0	U-0	U-0	U-0
—	—	—	—	—	—	—	—
bit 15						bit 8	

U-0	U-0	U-0	R/W-0	R/W-0	R/W-0	R/W-0	U-0
—	—	—	SMBUSDEL	OC1TRIS <sup>(2,3)</sup>	RTSECSEL1 <sup>(1,3)</sup>	RTSECSEL0 <sup>(1,3)</sup>	—
bit 7							bit 0

### Legend:

R = Readable bit      W = Writable bit      U = Unimplemented bit, read as '0'  
 -n = Value at POR      '1' = Bit is set      '0' = Bit is cleared      x = Bit is unknown

bit 15-5      **Unimplemented:** Read as '0'

bit 4      **SMBUSDEL:** SMBus SDA Input Delay Select bit

1 = The I<sup>2</sup>C module is configured for a longer SMBus input delay (nominal 300 ns delay)  
 0 = The I<sup>2</sup>C module is configured for a legacy input delay (nominal 150 ns delay)

bit 0      **Unimplemented:** Read as '0'

**Note 1:** To enable the actual RTCC output, the RTCOE (RCFGCAL<10>) bit needs to be set.

**Note 2:** To enable the actual OC1 output, the OCPWM1 module has to be enabled.

**Note 3:** Bits<3:1> are described in related chapters.

## 18.0 UNIVERSAL ASYNCHRONOUS RECEIVER TRANSMITTER (UART)

**Note:** This data sheet summarizes the features of this group of PIC24F devices. It is not intended to be a comprehensive reference source. For more information on the Universal Asynchronous Receiver Transmitter, refer to the “PIC24F Family Reference Manual”, Section 21. “UART” (DS39708).

The Universal Asynchronous Receiver Transmitter (UART) module is one of the serial I/O modules available in this PIC24F device family. The UART is a full-duplex asynchronous system that can communicate with peripheral devices, such as personal computers, LIN, RS-232 and RS-485 interfaces. This module also supports a hardware flow control option with the UxCTS and UxRTS pins, and also includes an IrDA® encoder and decoder.

The primary features of the UART module are:

- Full-Duplex, 8-Bit or 9-Bit Data Transmission through the UxTX and UxRX Pins
- Even, Odd or No Parity Options (for 8-bit data)
- One or Two Stop bits
- Hardware Flow Control Option with  $\overline{\text{UxCTS}}$  and  $\overline{\text{UxRTS}}$  pins

- Fully Integrated Baud Rate Generator (IBRG) with 16-Bit Prescaler
- Baud Rates Ranging from 1 Mbps to 15 bps at 16 MIPS
- 4-Deep, First-In-First-Out (FIFO) Transmit Data Buffer
- 4-Deep FIFO Receive Data Buffer
- Parity, Framing and Buffer Overrun Error Detection
- Support for 9-Bit mode with Address Detect (9<sup>th</sup> bit = 1)
- Transmit and Receive Interrupts
- Loopback mode for Diagnostic Support
- Support for Sync and Break Characters
- Supports Automatic Baud Rate Detection
- IrDA Encoder and Decoder Logic
- 16x Baud Clock Output for IrDA Support

A simplified block diagram of the UART is displayed in Figure 18-1. The UART module consists of these important hardware elements:

- Baud Rate Generator
- Asynchronous Transmitter
- Asynchronous Receiver

**FIGURE 18-1: UART SIMPLIFIED BLOCK DIAGRAM**

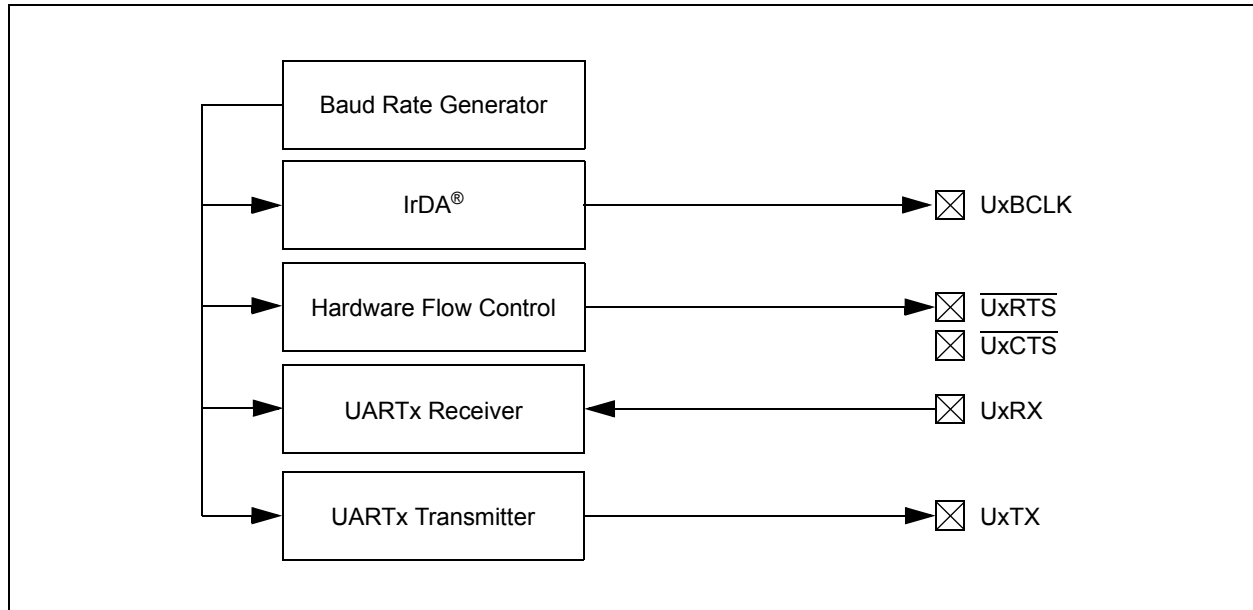

# PIC24F16KA102 FAMILY

## 18.1 UART Baud Rate Generator (BRG)

The UART module includes a dedicated 16-bit Baud Rate Generator (BRG). The UxBRG register controls the period of a free-running, 16-bit timer. Equation 18-1 provides the formula for computation of the baud rate with BRGH = 0.

### EQUATION 18-1: UART BAUD RATE WITH BRGH = 0<sup>(1)</sup>

$$\text{Baud Rate} = \frac{\text{FCY}}{16 \cdot (\text{UxBRG} + 1)}$$

$$\text{UxBRG} = \frac{\text{FCY}}{16 \cdot \text{Baud Rate}} - 1$$

**Note 1:** Based on FCY = FOSC/2; Doze mode and PLL are disabled.

Example 18-1 provides the calculation of the baud rate error for the following conditions:

- FCY = 4 MHz
- Desired Baud Rate = 9600

The maximum baud rate (BRGH = 0) possible is FCY/16 (for UxBRG = 0) and the minimum baud rate possible is FCY/(16 \* 65536).

Equation 18-2 provides the formula for computation of the baud rate with BRGH = 1.

### EQUATION 18-2: UART BAUD RATE WITH BRGH = 1<sup>(1)</sup>

$$\text{Baud Rate} = \frac{\text{FCY}}{4 \cdot (\text{UxBRG} + 1)}$$

$$\text{UxBRG} = \frac{\text{FCY}}{4 \cdot \text{Baud Rate}} - 1$$

**Note 1:** Based on FCY = FOSC/2; Doze mode and PLL are disabled.

The maximum baud rate (BRGH = 1) possible is FCY/4 (for UxBRG = 0) and the minimum baud rate possible is FCY/(4 \* 65536).

Writing a new value to the UxBRG register causes the BRG timer to be reset (cleared). This ensures the BRG does not wait for a timer overflow before generating the new baud rate.

### EXAMPLE 18-1: BAUD RATE ERROR CALCULATION (BRGH = 0)<sup>(1)</sup>

$$\text{Desired Baud Rate} = \text{FCY}/(16 (\text{UxBRG} + 1))$$

Solving for UxBRG value:

$$\text{UxBRG} = ((\text{FCY}/\text{Desired Baud Rate})/16) - 1$$

$$\text{UxBRG} = ((4000000/9600)/16) - 1$$

$$\text{UxBRG} = 25$$

$$\begin{aligned} \text{Calculated Baud Rate} &= 4000000/(16 (25 + 1)) \\ &= 9615 \end{aligned}$$

$$\begin{aligned} \text{Error} &= (\text{Calculated Baud Rate} - \text{Desired Baud Rate}) \\ &\quad \text{Desired Baud Rate} \\ &= (9615 - 9600)/9600 \\ &= 0.16\% \end{aligned}$$

**Note 1:** Based on FCY = FOSC/2; Doze mode and PLL are disabled.

## 18.2 Transmitting in 8-Bit Data Mode

1. Set up the UART:
  - a) Write appropriate values for data, parity and Stop bits.
  - b) Write appropriate baud rate value to the UxBRG register.
  - c) Set up transmit and receive interrupt enable and priority bits.
2. Enable the UART.
3. Set the UTXEN bit (causes a transmit interrupt two cycles after being set).
4. Write data byte to lower byte of UxTXREG word. The value will be immediately transferred to the Transmit Shift Register (TSR) and the serial bit stream will start shifting out with the next rising edge of the baud clock.
5. Alternately, the data byte may be transferred while UTXEN = 0, and then, the user may set UTXEN. This will cause the serial bit stream to begin immediately because the baud clock will start from a cleared state.
6. A transmit interrupt will be generated as per interrupt control bit, UTXISELx.

## 18.3 Transmitting in 9-Bit Data Mode

1. Set up the UART (as described in [Section 18.2 “Transmitting in 8-Bit Data Mode”](#)).
2. Enable the UART.
3. Set the UTXEN bit (causes a transmit interrupt two cycles after being set).
4. Write UxTXREG as a 16-bit value only.
5. A word write to UxTXREG triggers the transfer of the 9-bit data to the TSR. The serial bit stream will start shifting out with the first rising edge of the baud clock.
6. A transmit interrupt will be generated as per the setting of control bit, UTXISELx.

## 18.4 Break and Sync Transmit Sequence

The following sequence will send a message frame header made up of a Break, followed by an auto-baud Sync byte.

1. Configure the UART for the desired mode.
2. Set UTXEN and UTXBRK – sets up the Break character.
3. Load the UxTXREG with a dummy character to initiate transmission (value is ignored).
4. Write '55h' to UxTXREG – loads the Sync character into the transmit FIFO.
5. After the Break has been sent, the UTXBRK bit is reset by hardware. The Sync character now transmits.

## 18.5 Receiving in 8-Bit or 9-Bit Data Mode

1. Set up the UART (as described in [Section 18.2 “Transmitting in 8-Bit Data Mode”](#)).
2. Enable the UART.
3. A receive interrupt will be generated when one or more data characters have been received, as per interrupt control bit, URXISELx.
4. Read the OERR bit to determine if an overrun error has occurred. The OERR bit must be reset in software.
5. Read UxRXREG.

The act of reading the UxRXREG character will move the next character to the top of the receive FIFO, including a new set of PERR and FERR values.

## 18.6 Operation of $\overline{\text{UxCTS}}$ and $\overline{\text{UxRTS}}$ Control Pins

UARTx Clear to Send ( $\overline{\text{UxCTS}}$ ) and Request to Send ( $\overline{\text{UxRTS}}$ ) are the two hardware-controlled pins that are associated with the UART module. These two pins allow the UART to operate in Simplex and Flow Control modes. They are implemented to control the transmission and reception between the Data Terminal Equipment (DTE). The UEN<1:0> bits in the UxMODE register configure these pins.

## 18.7 Infrared Support

The UART module provides two types of infrared UART support: one is the IrDA clock output to support an external IrDA encoder and decoder device (legacy module support), and the other is the full implementation of the IrDA encoder and decoder.

As the IrDA modes require a 16x baud clock, they will only work when the BRGH bit (UxMODE<3>) is '0'.

### 18.7.1 EXTERNAL IrDA SUPPORT – IrDA CLOCK OUTPUT

To support external IrDA encoder and decoder devices, the UxBCLK pin (same as the  $\overline{\text{UxRTS}}$  pin) can be configured to generate the 16x baud clock. When UEN<1:0> = 11, the UxBCLK pin will output the 16x baud clock if the UART module is enabled; it can be used to support the IrDA codec chip.

### 18.7.2 BUILT-IN IrDA ENCODER AND DECODER

The UART has full implementation of the IrDA encoder and decoder as part of the UART module. The built-in IrDA encoder and decoder functionality is enabled using the IREN bit (UxMODE<12>). When enabled (IREN = 1), the receive pin (UxRX) acts as the input from the infrared receiver. The transmit pin (UxTX) acts as the output to the infrared transmitter.

# PIC24F16KA102 FAMILY

## REGISTER 18-1: UxMODE: UARTx MODE REGISTER

R/W-0	U-0	R/W-0	R/W-0	R/W-0	U-0	R/W-0 <sup>(2)</sup>	R/W-0 <sup>(2)</sup>
UARTEN	—	USIDL	IREN <sup>(1)</sup>	RTSMD	—	UEN1	UEN0
bit 15							bit 8

R/C-0, HC	R/W-0	R/W-0, HC	R/W-0	R/W-0	R/W-0	R/W-0	R/W-0
WAKE	LPBACK	ABAUD	RXINV	BRGH	PDSEL1	PDSEL0	STSEL
bit 7							bit 0

<b>Legend:</b>	C = Clearable bit	HC = Hardware Clearable bit
R = Readable bit	W = Writable bit	U = Unimplemented bit, read as '0'
-n = Value at POR	'1' = Bit is set	'0' = Bit is cleared      x = Bit is unknown

- bit 15      **UARTEN:** UARTx Enable bit  
 1 = UARTx is enabled; all UARTx pins are controlled by UARTx as defined by UEN<1:0>  
 0 = UARTx is disabled; all UARTx pins are controlled by port latches; UARTx power consumption is minimal
- bit 14      **Unimplemented:** Read as '0'
- bit 13      **USIDL:** Stop in Idle Mode bit  
 1 = Discontinue module operation when device enters Idle mode  
 0 = Continue module operation in Idle mode
- bit 12      **IREN:** IrDA<sup>®</sup> Encoder and Decoder Enable bit<sup>(1)</sup>  
 1 = IrDA encoder and decoder are enabled  
 0 = IrDA encoder and decoder are disabled
- bit 11      **RTSMD:** Mode Selection for  $\overline{UxRTS}$  Pin bit  
 1 =  $\overline{UxRTS}$  pin is in Simplex mode  
 0 =  $\overline{UxRTS}$  pin is in Flow Control mode
- bit 10      **Unimplemented:** Read as '0'
- bit 9-8      **UEN<1:0>:** UARTx Enable bits<sup>(2)</sup>  
 11 =  $\overline{UxTX}$ ,  $\overline{UxRX}$  and  $\overline{UxBCLK}$  pins are enabled and used;  $\overline{UxCTS}$  pin is controlled by port latches  
 10 =  $\overline{UxTX}$ ,  $\overline{UxRX}$ ,  $\overline{UxCTS}$  and  $\overline{UxRTS}$  pins are enabled and used  
 01 =  $\overline{UxTX}$ ,  $\overline{UxRX}$  and  $\overline{UxRTS}$  pins are enabled and used;  $\overline{UxCTS}$  pin is controlled by port latches  
 00 =  $\overline{UxTX}$  and  $\overline{UxRX}$  pins are enabled and used;  $\overline{UxCTS}$  and  $\overline{UxRTS}/\overline{UxBCLK}$  pins are controlled by port latches
- bit 7      **WAKE:** Wake-up on Start Bit Detect During Sleep Mode Enable bit  
 1 = UARTx will continue to sample the  $\overline{UxRX}$  pin; interrupt generated on falling edge, bit is cleared in hardware on the following rising edge  
 0 = No wake-up is enabled
- bit 6      **LPBACK:** UARTx Loopback Mode Select bit  
 1 = Enable Loopback mode  
 0 = Loopback mode is disabled
- bit 5      **ABAUD:** Auto-Baud Enable bit  
 1 = Enable baud rate measurement on the next character – requires reception of a Sync field (55h); cleared in hardware upon completion  
 0 = Baud rate measurement is disabled or completed
- bit 4      **RXINV:** Receive Polarity Inversion bit  
 1 =  $\overline{UxRX}$  Idle state is '0'  
 0 =  $\overline{UxRX}$  Idle state is '1'

**Note 1:** This feature is only available for the 16x BRG mode (BRGH = 0).

**2:** Bit availability depends on pin availability.

# PIC24F16KA102 FAMILY

---

## REGISTER 18-1: UxMODE: UARTx MODE REGISTER (CONTINUED)

- bit 3        **BRGH:** High Baud Rate Enable bit  
            1 = BRG generates 4 clocks per bit period (4x baud clock, High-Speed mode)  
            0 = BRG generates 16 clocks per bit period (16x baud clock, Standard mode)
- bit 2-1     **PDSEL<1:0>:** Parity and Data Selection bits  
            11 = 9-bit data, no parity  
            10 = 8-bit data, odd parity  
            01 = 8-bit data, even parity  
            00 = 8-bit data, no parity
- bit 0        **STSEL:** Stop Bit Selection bit  
            1 = Two Stop bits  
            0 = One Stop bit

**Note 1:** This feature is only available for the 16x BRG mode (BRGH = 0).

**2:** Bit availability depends on pin availability.

# PIC24F16KA102 FAMILY

## REGISTER 18-2: UxSTA: UARTx STATUS AND CONTROL REGISTER

R/W-0	R/W-0	R/W-0	U-0	R/W-0, HC	R/W-0	R-0, HSC	R-1, HSC
UTXISEL1	UTXINV	UTXISEL0	—	UTXBRK	UTXEN	UTXBF	TRMT
bit 15							bit 8

R/W-0	R/W-0	R/W-0	R-1, HSC	R-0, HSC	R-0, HSC	R/C-0, HS	R-0, HSC
URXISEL1	URXISEL0	ADDEN	RIDL	PERR	FERR	OERR	URXDA
bit 7							bit 0

<b>Legend:</b>	HC = Hardware Clearable bit
C = Clearable bit	HS = Hardware Settable bit    HSC = Hardware Settable/Clearable bit
R = Readable bit	W = Writable bit                    U = Unimplemented bit, read as '0'
-n = Value at POR	'1' = Bit is set                        '0' = Bit is cleared                    x = Bit is unknown

- bit 15,13    **UTXISEL<1:0>**: Transmission Interrupt Mode Selection bits  
 11 = Reserved; do not use  
 10 = Interrupt when a character is transferred to the Transmit Shift Register (TSR), and as a result, the transmit buffer becomes empty  
 01 = Interrupt when the last character is shifted out of the Transmit Shift Register; all transmit operations are completed  
 00 = Interrupt when a character is transferred to the Transmit Shift Register (this implies there is at least one character open in the transmit buffer)
- bit 14    **UTXINV**: IrDA<sup>®</sup> Encoder Transmit Polarity Inversion bit  
If IREN = 0:  
 1 = UxTX Idle '0'  
 0 = UxTX Idle '1'  
If IREN = 1:  
 1 = UxTX Idle '1'  
 0 = UxTX Idle '0'
- bit 12    **Unimplemented**: Read as '0'
- bit 11    **UTXBRK**: Transmit Break bit  
 1 = Send Sync Break on next transmission – Start bit, followed by twelve '0' bits, followed by Stop bit; cleared by hardware upon completion  
 0 = Sync Break transmission is disabled or completed
- bit 10    **UTXEN**: Transmit Enable bit  
 1 = Transmit is enabled, UxTX pin is controlled by UARTx  
 0 = Transmit is disabled, any pending transmission is aborted and buffer is reset. UxTX pin is controlled by the PORT register.
- bit 9    **UTXBF**: Transmit Buffer Full Status bit (read-only)  
 1 = Transmit buffer is full  
 0 = Transmit buffer is not full, at least one more character can be written
- bit 8    **TRMT**: Transmit Shift Register Empty bit (read-only)  
 1 = Transmit Shift Register is empty and transmit buffer is empty (the last transmission has completed)  
 0 = Transmit Shift Register is not empty, a transmission is in progress or queued
- bit 7-6    **URXISEL<1:0>**: Receive Interrupt Mode Selection bits  
 11 = Interrupt is set on RSR transfer, making the receive buffer full (i.e., has 4 data characters)  
 10 = Interrupt is set on RSR transfer, making the receive buffer 3/4 full (i.e., has 3 data characters)  
 0x = Interrupt is set when any character is received and transferred from the RSR to the receive buffer; receive buffer has one or more characters



# PIC24F16KA102 FAMILY

---

## REGISTER 18-2: UxSTA: UARTx STATUS AND CONTROL REGISTER (CONTINUED)

- bit 5      **ADDEN:** Address Character Detect bit (bit 8 of received data = 1)  
1 = Address Detect mode is enabled. If 9-bit mode is not selected, this does not take effect.  
0 = Address Detect mode is disabled
- bit 4      **RIDLE:** Receiver Idle bit (read-only)  
1 = Receiver is Idle  
0 = Receiver is active
- bit 3      **PERR:** Parity Error Status bit (read-only)  
1 = Parity error has been detected for the current character (character at the top of the receive FIFO)  
0 = Parity error has not been detected
- bit 2      **FERR:** Framing Error Status bit (read-only)  
1 = Framing error has been detected for the current character (character at the top of the receive FIFO)  
0 = Framing error has not been detected
- bit 1      **OERR:** Receive Buffer Overrun Error Status bit (clear/read-only)  
1 = Receive buffer has overflowed  
0 = Receive buffer has not overflowed (clearing a previously set OERR bit (1 → 0 transition) will reset the receiver buffer and the RSR to the empty state)
- bit 0      **URXDA:** Receive Buffer Data Available bit (read-only)  
1 = Receive buffer has data; at least one more character can be read  
0 = Receive buffer is empty

# PIC24F16KA102 FAMILY

## REGISTER 18-3: UxTXREG: UARTx TRANSMIT REGISTER

U-x	U-x	U-x	U-x	U-x	U-x	U-x	W-x
—	—	—	—	—	—	—	UTX8
bit 15							bit 8

W-x	W-x	W-x	W-x	W-x	W-x	W-x	W-x
UTX7	UTX6	UTX5	UTX4	UTX3	UTX2	UTX1	UTX0
bit 7							bit 0

### Legend:

R = Readable bit                      W = Writable bit                      U = Unimplemented bit, read as '0'  
 -n = Value at POR                      '1' = Bit is set                      '0' = Bit is cleared                      x = Bit is unknown

bit 15-9            **Unimplemented:** Read as '0'  
 bit 8                **UTX8:** Data of the Transmitted Character bit (in 9-bit mode)  
 bit 7-0             **UTX<7:0>:** Data of the Transmitted Character bits

## REGISTER 18-4: UxRXREG: UARTx RECEIVE REGISTER

U-0	U-0	U-0	U-0	U-0	U-0	U-0	R-0, HSC
—	—	—	—	—	—	—	URX8
bit 15							bit 8

R-0, HSC	R-0, HSC	R-0, HSC	R-0, HSC	R-0, HSC	R-0, HSC	R-0, HSC	R-0, HSC
URX7	URX6	URX5	URX4	URX3	URX2	URX1	URX0
bit 7							bit 0

### Legend:

HSC = Hardware Settable/Clearable bit  
 R = Readable bit                      W = Writable bit                      U = Unimplemented bit, read as '0'  
 -n = Value at POR                      '1' = Bit is set                      '0' = Bit is cleared                      x = Bit is unknown

bit 15-9            **Unimplemented:** Read as '0'  
 bit 8                **URX8:** Data of the Received Character bit (in 9-bit mode)  
 bit 7-0             **URX<7:0>:** Data of the Received Character bits

# PIC24F16KA102 FAMILY

## 19.0 REAL-TIME CLOCK AND CALENDAR (RTCC)

**Note:** This data sheet summarizes the features of this group of PIC24F devices. It is not intended to be a comprehensive reference source. For more information on the Real-Time Clock and Calendar, refer to the "PIC24F Family Reference Manual", Section 29. "Real-Time Clock and Calendar (RTCC)" (DS39696).

The RTCC provides the user with a Real-Time Clock and Calendar (RTCC) function that can be calibrated.

Key features of the RTCC module are:

- Operates in Deep Sleep mode
- Selectable clock source
- Provides hours, minutes and seconds using 24-hour format
- Visibility of one half second period
- Provides calendar – weekday, date, month and year
- Alarm-configurable for half a second, one second, 10 seconds, one minute, 10 minutes, one hour,

one day, one week, one month or one year

- Alarm repeat with decrementing counter
- Alarm with indefinite repeat chime
- Year 2000 to 2099 leap year correction
- BCD format for smaller software overhead
- Optimized for long-term battery operation
- User calibration of the 32.768 kHz clock crystal/32K INTRC frequency with periodic auto-adjust

### 19.1 RTCC Source Clock

The user can select between the SOSC crystal oscillator or the LPRC internal oscillator as the clock reference for the RTCC module. This is configured using the RTCOSC (FDS<5>) Configuration bit. This gives the user an option to trade off system cost, accuracy and power consumption, based on the overall system needs.

The RTCC will continue to run, along with its chosen clock source, while the device is held in Reset with MCLR and will continue running after MCLR is released.

**FIGURE 19-1: RTCC BLOCK DIAGRAM**



# PIC24F16KA102 FAMILY

## 19.2 RTCC Module Registers

The RTCC module registers are organized into three categories:

- RTCC Control Registers
- RTCC Value Registers
- Alarm Value Registers

### 19.2.1 REGISTER MAPPING

To limit the register interface, the RTCC Timer and Alarm Time registers are accessed through corresponding register pointers. The RTCC Value register window (RTCVALH and RTCVALL) uses the RTCPTR bits (RCFGCAL<9:8>) to select the desired Timer register pair (see [Table 19-1](#)).

By writing the RTCVALH byte, the RTCC Pointer value, the RTCPTR<1:0> bits decrement by one until they reach '00'. Once they reach '00', the MINUTES and SECONDS value will be accessible through RTCVALH and RTCVALL until the pointer value is manually changed.

**TABLE 19-1: RTCVAL REGISTER MAPPING**

RTCPTR<1:0>	RTCC Value Register Window	
	RTCVAL<15:8>	RTCVAL<7:0>
00	MINUTES	SECONDS
01	WEEKDAY	HOURS
10	MONTH	DAY
11	—	YEAR

The Alarm Value register window (ALRMVALH and ALRMVALL) uses the ALRMPTR bits (ALCFGRPT<9:8>) to select the desired Alarm register pair (see [Table 19-2](#)).

By writing the ALRMVALH byte, the Alarm Pointer value bits (ALRMPTR<1:0>) decrement by one until they reach '00'. Once they reach '00', the ALRMMIN and ALRMSEC value will be accessible through ALRMVALH and ALRMVALL until the pointer value is manually changed.

### EXAMPLE 19-1: SETTING THE RTCWREN BIT

```
asm volatile ("push w7")           ;
asm volatile ("push w8")           ;
asm volatile ("disi #5")           ;
asm volatile ("mov #0x55, w7")     ;
asm volatile ("mov w7, _NVMKEY")   ;
asm volatile ("mov #0xAA, w8")     ;
asm volatile ("mov w8, _NVMKEY")   ;
asm volatile ("bset _RCFGCAL, #13") ; //set the RTCWREN bit
asm volatile ("pop w8")            ;
asm volatile ("pop w7");
```

**TABLE 19-2: ALRMVAL REGISTER MAPPING**

ALRMPTR <1:0>	Alarm Value Register Window	
	ALRMVAL<15:8>	ALRMVAL<7:0>
00	ALRMMIN	ALRMSEC
01	ALRMWD	ALRMHR
10	ALRMMNTH	ALRMDAY
11	—	—

Considering that the 16-bit core does not distinguish between 8-bit and 16-bit read operations, the user must be aware that when reading either the ALRMVALH or ALRMVALL bytes, the ALRMPTR<1:0> value will be decremented. The same applies to the RTCVALH or RTCVALL bytes with the RTCPTR<1:0> being decremented.

**Note:** This only applies to read operations and not write operations.

### 19.2.2 WRITE LOCK

In order to perform a write to any of the RTCC Timer registers, the RTCWREN bit (RCFGCAL<13>) must be set (refer to [Example 19-1](#)).

**Note:** To avoid accidental writes to the timer, it is recommended that the RTCWREN bit (RCFGCAL<13>) is kept clear at any other time. For the RTCWREN bit to be set, there is only one instruction cycle time window allowed between the 55h/AA sequence and the setting of RTCWREN; therefore, it is recommended that code follow the procedure in [Example 19-1](#).

### 19.2.3 SELECTING RTCC CLOCK SOURCE

The clock source for the RTCC module can be selected using the RTCOSC (FDS<5>) bit. When the bit is set to '1', the Secondary Oscillator (SOSC) is used as the reference clock and when the bit is '0', LPRC is used as the reference clock.

# PIC24F16KA102 FAMILY

## 19.2.4 RTCC CONTROL REGISTERS

### REGISTER 19-1: RCFGAL: RTCC CALIBRATION AND CONFIGURATION REGISTER<sup>(1)</sup>

R/W-0	U-0	R/W-0	R-0, HSC	R-0, HSC	R/W-0	R/W-0	R/W-0
RTCEN <sup>(2)</sup>	—	RTCWREN	RTCSYNC	HALFSEC <sup>(3)</sup>	RTCOE	RTCPTR1	RTCPTR0
bit 15						bit 8	

R/W-0	R/W-0	R/W-0	R/W-0	R/W-0	R/W-0	R/W-0	R/W-0
CAL7	CAL6	CAL5	CAL4	CAL3	CAL2	CAL1	CAL0
bit 7						bit 0	

<b>Legend:</b>	HSC = Hardware Settable/Clearable bit
R = Readable bit	W = Writable bit
-n = Value at POR	'1' = Bit is set
	'0' = Bit is cleared
	x = Bit is unknown
	U = Unimplemented bit, read as '0'

- bit 15     **RTCEN:** RTCC Enable bit<sup>(2)</sup>  
           1 = RTCC module is enabled  
           0 = RTCC module is disabled
- bit 14     **Unimplemented:** Read as '0'
- bit 13     **RTCWREN:** RTCC Value Registers Write Enable bit  
           1 = RTCVALH and RTCVALL registers can be written to by the user  
           0 = RTCVALH and RTCVALL registers are locked out from being written to by the user
- bit 12     **RTCSYNC:** RTCC Value Registers Read Synchronization bit  
           1 = RTCVALH, RTCVALL and ALCFGRPT registers can change while reading due to a rollover ripple, resulting in an invalid data read. If the register is read twice and results in the same data, the data can be assumed to be valid.  
           0 = RTCVALH, RTCVALL or ALCFGRPT registers can be read without concern over a rollover ripple
- bit 11     **HALFSEC:** Half Second Status bit<sup>(3)</sup>  
           1 = Second half period of a second  
           0 = First half period of a second
- bit 10     **RTCOE:** RTCC Output Enable bit  
           1 = RTCC output is enabled  
           0 = RTCC output is disabled
- bit 9-8    **RTCPTR<1:0>:** RTCC Value Register Window Pointer bits  
           Points to the corresponding RTCC Value registers when reading the RTCVALH and RTCVALL registers. The RTCPTR<1:0> value decrements on every read or write of RTCVALH until it reaches '00'.  
           RTCVAL<15:8>:  
           00 = MINUTES  
           01 = WEEKDAY  
           10 = MONTH  
           11 = Reserved  
           RTCVAL<7:0>:  
           00 = SECONDS  
           01 = HOURS  
           10 = DAY  
           11 = YEAR

- Note 1:** The RCFGAL register is only affected by a POR.  
**Note 2:** A write to the RTCEN bit is only allowed when RTCWREN = 1.  
**Note 3:** This bit is read-only; it is cleared to '0' on a write to the lower half of the MINSEC register.

# PIC24F16KA102 FAMILY

## REGISTER 19-1: RCFGAL: RTCC CALIBRATION AND CONFIGURATION REGISTER<sup>(1)</sup> (CONTINUED)

bit 7-0      **CAL<7:0>**: RTC Drift Calibration bits  
 01111111 = Maximum positive adjustment; adds 508 RTC clock pulses every one minute  
 .  
 .  
 .  
 01111111 = Minimum positive adjustment; adds 4 RTC clock pulses every one minute  
 00000000 = No adjustment  
 11111111 = Minimum negative adjustment; subtracts 4 RTC clock pulses every one minute  
 .  
 .  
 .  
 10000000 = Maximum negative adjustment; subtracts 512 RTC clock pulses every one minute

- Note 1:** The RCFGAL register is only affected by a POR.  
**Note 2:** A write to the RTCEN bit is only allowed when RTCWREN = 1.  
**Note 3:** This bit is read-only; it is cleared to '0' on a write to the lower half of the MINSEC register.

## REGISTER 19-2: PADCFG1: PAD CONFIGURATION CONTROL REGISTER

U-0	U-0	U-0	U-0	U-0	U-0	U-0	U-0
—	—	—	—	—	—	—	—
bit 15							bit 8

U-0	U-0	U-0	R/W-0	R/W-0	R/W-0	R/W-0	U-0
—	—	—	SMBUSDEL	OC1TRIS	RTSECSEL1 <sup>(1)</sup>	RTSECSEL0 <sup>(1)</sup>	—
bit 7							bit 0

### Legend:

R = Readable bit      W = Writable bit      U = Unimplemented bit, read as '0'  
 -n = Value at POR      '1' = Bit is set      '0' = Bit is cleared      x = Bit is unknown

bit 15-5      **Unimplemented:** Read as '0'  
 bit 4-3      Described in [Section 15.0 “Output Compare”](#) and [Section 17.0 “Inter-Integrated Circuit \(I<sup>2</sup>C™\)”](#).  
 bit 2-1      **RTSECSEL<1:0>**: RTCC Seconds Clock Output Select bits<sup>(1)</sup>  
 11 = Reserved; do not use  
 10 = RTCC source clock is selected for the RTCC pin (can be LPRC or SOSC, depending on the RTCOSC (FDS<5>) bit setting)  
 01 = RTCC seconds clock is selected for the RTCC pin  
 00 = RTCC alarm pulse is selected for the RTCC pin  
 bit 0      **Unimplemented:** Read as '0'

- Note 1:** To enable the actual RTCC output, the RTCOE (RCFGAL<10>) bit needs to be set.

# PIC24F16KA102 FAMILY

## REGISTER 19-3: ALCFGRPT: ALARM CONFIGURATION REGISTER

R/W-0	R/W-0	R/W-0	R/W-0	R/W-0	R/W-0	R/W-0	R/W-0
ALRMEN	CHIME	AMASK3	AMASK2	AMASK1	AMASK0	ALRMPTR1	ALRMPTR0
bit 15						bit 8	

R/W-0	R/W-0	R/W-0	R/W-0	R/W-0	R/W-0	R/W-0	R/W-0
ARPT7	ARPT6	ARPT5	ARPT4	ARPT3	ARPT2	ARPT1	ARPT0
bit 7						bit 0	

### Legend:

R = Readable bit                      W = Writable bit                      U = Unimplemented bit, read as '0'  
 -n = Value at POR                      '1' = Bit is set                      '0' = Bit is cleared                      x = Bit is unknown

- bit 15      **ALRMEN:** Alarm Enable bit  
 1 = Alarm is enabled (cleared automatically after an alarm event whenever ARPT<7:0> = 00h and CHIME = 0)  
 0 = Alarm is disabled
- bit 14      **CHIME:** Chime Enable bit  
 1 = Chime is enabled; ARPT<7:0> bits are allowed to roll over from 00h to FFh  
 0 = Chime is disabled; ARPT<7:0> bits stop once they reach 00h
- bit 13-10    **AMASK<3:0>:** Alarm Mask Configuration bits  
 0000 = Every half second  
 0001 = Every second  
 0010 = Every 10 seconds  
 0011 = Every minute  
 0100 = Every 10 minutes  
 0101 = Every hour  
 0110 = Once a day  
 0111 = Once a week  
 1000 = Once a month  
 1001 = Once a year (except when configured for February 29<sup>th</sup>, once every 4 years)  
 101x = Reserved – do not use  
 11xx = Reserved – do not use
- bit 9-8      **ALRMPTR<1:0>:** Alarm Value Register Window Pointer bits  
 Points to the corresponding Alarm Value registers when reading the ALRMVALH and ALRMVALL registers. The ALRMPTR<1:0> value decrements on every read or write of ALRMVALH until it reaches '00'.  
ALRMVAL<15:8>:  
 00 = ALRMMIN  
 01 = ALRMWD  
 10 = ALRMMNTH  
 11 = Unimplemented  
ALRMVAL<7:0>:  
 00 = ALRMSEC  
 01 = ALRMHR  
 10 = ALRMDAY  
 11 = Unimplemented
- bit 7-0      **ARPT<7:0>:** Alarm Repeat Counter Value bits  
 11111111 = Alarm will repeat 255 more times  
 .  
 .  
 .  
 00000000 = Alarm will not repeat  
 The counter decrements on any alarm event; it is prevented from rolling over from 00h to FFh unless CHIME = 1.

# PIC24F16KA102 FAMILY

## 19.2.5 RTCVAL REGISTER MAPPINGS

### REGISTER 19-4: YEAR: YEAR VALUE REGISTER<sup>(1)</sup>

U-0	U-0	U-0	U-0	U-0	U-0	U-0	U-0
—	—	—	—	—	—	—	—
bit 15							bit 8

R/W-x	R/W-x	R/W-x	R/W-x	R/W-x	R/W-x	R/W-x	R/W-x
YRTEN3	YRTEN2	YRTEN1	YRTEN0	YRONE3	YRONE2	YRONE1	YRONE0
bit 7							bit 0

#### Legend:

R = Readable bit                      W = Writable bit                      U = Unimplemented bit, read as '0'  
 -n = Value at POR                      '1' = Bit is set                      '0' = Bit is cleared                      x = Bit is unknown

- bit 15-8        **Unimplemented:** Read as '0'
- bit 7-4        **YRTEN<3:0>:** Binary Coded Decimal Value of Year's Tens Digit bits  
                   Contains a value from 0 to 9.
- bit 3-0        **YRONE<3:0>:** Binary Coded Decimal Value of Year's Ones Digit bits  
                   Contains a value from 0 to 9.

**Note 1:** A write to the YEAR register is only allowed when RTCWREN = 1.

### REGISTER 19-5: MTHDY: MONTH AND DAY VALUE REGISTER<sup>(1)</sup>

U-0	U-0	U-0	R/W-x	R/W-x	R/W-x	R/W-x	R/W-x
—	—	—	MHTEN0	MTHONE3	MTHONE2	MTHONE1	MTHONE0
bit 15							bit 8

U-0	U-0	R/W-x	R/W-x	R/W-x	R/W-x	R/W-x	R/W-x
—	—	DAYTEN1	DAYTEN0	DAYONE3	DAYONE2	DAYONE1	DAYONE0
bit 7							bit 0

#### Legend:

R = Readable bit                      W = Writable bit                      U = Unimplemented bit, read as '0'  
 -n = Value at POR                      '1' = Bit is set                      '0' = Bit is cleared                      x = Bit is unknown

- bit 15-13      **Unimplemented:** Read as '0'
- bit 12        **MHTEN0:** Binary Coded Decimal Value of Month's Tens Digit bit  
                   Contains a value of '0' or '1'.
- bit 11-8      **MTHONE<3:0>:** Binary Coded Decimal Value of Month's Ones Digit bits  
                   Contains a value from 0 to 9.
- bit 7-6        **Unimplemented:** Read as '0'
- bit 5-4        **DAYTEN<1:0>:** Binary Coded Decimal Value of Day's Tens Digit bits  
                   Contains a value from 0 to 3.
- bit 3-0        **DAYONE<3:0>:** Binary Coded Decimal Value of Day's Ones Digit bits  
                   Contains a value from 0 to 9.

**Note 1:** A write to this register is only allowed when RTCWREN = 1.



# PIC24F16KA102 FAMILY

## REGISTER 19-6: WKDYHR: WEEKDAY AND HOURS VALUE REGISTER<sup>(1)</sup>

U-0	U-0	U-0	U-0	U-0	R/W-x	R/W-x	R/W-x
—	—	—	—	—	WDAY2	WDAY1	WDAY0
bit 15					bit 8		

U-0	U-0	R/W-x	R/W-x	R/W-x	R/W-x	R/W-x	R/W-x
—	—	HRTEN1	HRTEN0	HRONE3	HRONE2	HRONE1	HRONE0
bit 7		bit 0					

### Legend:

R = Readable bit                      W = Writable bit                      U = Unimplemented bit, read as '0'  
 -n = Value at POR                      '1' = Bit is set                      '0' = Bit is cleared                      x = Bit is unknown

- bit 15-11      **Unimplemented:** Read as '0'
- bit 10-8      **WDAY<2:0>:** Binary Coded Decimal Value of Weekday Digit bits  
Contains a value from 0 to 6.
- bit 7-6        **Unimplemented:** Read as '0'
- bit 5-4        **HRTEN<1:0>:** Binary Coded Decimal Value of Hour's Tens Digit bits  
Contains a value from 0 to 2.
- bit 3-0        **HRONE<3:0>:** Binary Coded Decimal Value of Hour's Ones Digit bits  
Contains a value from 0 to 9.

**Note 1:** A write to this register is only allowed when RTCWREN = 1.

## REGISTER 19-7: MINSEC: MINUTES AND SECONDS VALUE REGISTER

U-0	R/W-x	R/W-x	R/W-x	R/W-x	R/W-x	R/W-x	R/W-x
—	MINTEN2	MINTEN1	MINTEN0	MINONE3	MINONE2	MINONE1	MINONE0
bit 15					bit 8		

U-0	R/W-x	R/W-x	R/W-x	R/W-x	R/W-x	R/W-x	R/W-x
—	SECTEN2	SECTEN1	SECTEN0	SECONE3	SECONE2	SECONE1	SECONE0
bit 7		bit 0					

### Legend:

R = Readable bit                      W = Writable bit                      U = Unimplemented bit, read as '0'  
 -n = Value at POR                      '1' = Bit is set                      '0' = Bit is cleared                      x = Bit is unknown

- bit 15        **Unimplemented:** Read as '0'
- bit 14-12    **MINTEN<2:0>:** Binary Coded Decimal Value of Minute's Tens Digit bits  
Contains a value from 0 to 5.
- bit 11-8    **MINONE<3:0>:** Binary Coded Decimal Value of Minute's Ones Digit bits  
Contains a value from 0 to 9.
- bit 7        **Unimplemented:** Read as '0'
- bit 6-4     **SECTEN<2:0>:** Binary Coded Decimal Value of Second's Tens Digit bits  
Contains a value from 0 to 5.
- bit 3-0     **SECONE<3:0>:** Binary Coded Decimal Value of Second's Ones Digit bits  
Contains a value from 0 to 9.

# PIC24F16KA102 FAMILY

## 19.2.6 ALRMVAL REGISTER MAPPINGS

### REGISTER 19-8: ALMTHDY: ALARM MONTH AND DAY VALUE REGISTER<sup>(1)</sup>

U-0	U-0	U-0	R/W-x	R/W-x	R/W-x	R/W-x	R/W-x
—	—	—	MHTTEN0	MTHONE3	MTHONE2	MTHONE1	MTHONE0
bit 15							bit 8

U-0	U-0	R/W-x	R/W-x	R/W-x	R/W-x	R/W-x	R/W-x
—	—	DAYTEN1	DAYTEN0	DAYONE3	DAYONE2	DAYONE1	DAYONE0
bit 7							bit 0

#### Legend:

R = Readable bit                      W = Writable bit                      U = Unimplemented bit, read as '0'  
 -n = Value at POR                      '1' = Bit is set                      '0' = Bit is cleared                      x = Bit is unknown

- bit 15-13      **Unimplemented:** Read as '0'
- bit 12        **MHTTEN0:** Binary Coded Decimal Value of Month's Tens Digit bit  
Contains a value of '0' or '1'.
- bit 11-8     **MTHONE<3:0>:** Binary Coded Decimal Value of Month's Ones Digit bits  
Contains a value from 0 to 9.
- bit 7-6      **Unimplemented:** Read as '0'
- bit 5-4      **DAYTEN<1:0>:** Binary Coded Decimal Value of Day's Tens Digit bits  
Contains a value from 0 to 3.
- bit 3-0     **DAYONE<3:0>:** Binary Coded Decimal Value of Day's Ones Digit bits  
Contains a value from 0 to 9.

**Note 1:** A write to this register is only allowed when RTCWREN = 1.

### REGISTER 19-9: ALWDHR: ALARM WEEKDAY AND HOURS VALUE REGISTER<sup>(1)</sup>

U-0	U-0	U-0	U-0	U-0	R/W-x	R/W-x	R/W-x
—	—	—	—	—	WDAY2	WDAY1	WDAY0
bit 15							bit 8

U-0	U-0	R/W-x	R/W-x	R/W-x	R/W-x	R/W-x	R/W-x
—	—	HRTEN1	HRTEN0	HRONE3	HRONE2	HRONE1	HRONE0
bit 7							bit 0

#### Legend:

R = Readable bit                      W = Writable bit                      U = Unimplemented bit, read as '0'  
 -n = Value at POR                      '1' = Bit is set                      '0' = Bit is cleared                      x = Bit is unknown

- bit 15-11    **Unimplemented:** Read as '0'
- bit 10-8    **WDAY<2:0>:** Binary Coded Decimal Value of Weekday Digit bits  
Contains a value from 0 to 6.
- bit 7-6     **Unimplemented:** Read as '0'
- bit 5-4     **HRTEN<1:0>:** Binary Coded Decimal Value of Hour's Tens Digit bits  
Contains a value from 0 to 2.
- bit 3-0    **HRONE<3:0>:** Binary Coded Decimal Value of Hour's Ones Digit bits  
Contains a value from 0 to 9.

**Note 1:** A write to this register is only allowed when RTCWREN = 1.

# PIC24F16KA102 FAMILY

## REGISTER 19-10: ALMINSEC: ALARM MINUTES AND SECONDS VALUE REGISTER

U-0	R/W-x	R/W-x	R/W-x	R/W-x	R/W-x	R/W-x	R/W-x
—	MINTEN2	MINTEN1	MINTEN0	MINONE3	MINONE2	MINONE1	MINONE0
bit 15							bit 8

U-0	R/W-x	R/W-x	R/W-x	R/W-x	R/W-x	R/W-x	R/W-x
—	SECTEN2	SECTEN1	SECTEN0	SECONE3	SECONE2	SECONE1	SECONE0
bit 7							bit 0

### Legend:

R = Readable bit	W = Writable bit	U = Unimplemented bit, read as '0'
-n = Value at POR	'1' = Bit is set	'0' = Bit is cleared
		x = Bit is unknown

- bit 15      **Unimplemented:** Read as '0'
- bit 14-12    **MINTEN<2:0>:** Binary Coded Decimal Value of Minute's Tens Digit bits  
Contains a value from 0 to 5.
- bit 11-8     **MINONE<3:0>:** Binary Coded Decimal Value of Minute's Ones Digit bits  
Contains a value from 0 to 9.
- bit 7        **Unimplemented:** Read as '0'
- bit 6-4      **SECTEN<2:0>:** Binary Coded Decimal Value of Second's Tens Digit bits  
Contains a value from 0 to 5.
- bit 3-0      **SECONE<3:0>:** Binary Coded Decimal Value of Second's Ones Digit bits  
Contains a value from 0 to 9.

# PIC24F16KA102 FAMILY

## 19.3 Calibration

The real-time crystal input can be calibrated using the periodic auto-adjust feature. When properly calibrated, the RTCC can provide an error of less than 3 seconds per month. This is accomplished by finding the number of error clock pulses and storing the value into the lower half of the RCFGAL register. The 8-bit signed value loaded into the lower half of RCFGAL is multiplied by four and will either be added or subtracted from the RTCC timer, once every minute. Refer to the steps below for RTCC calibration:

1. Using another timer resource on the device, the user must find the error of the 32.768 kHz crystal.
2. Once the error is known, it must be converted to the number of error clock pulses per minute.
3.
  - a) If the oscillator is faster than ideal (negative result from Step 2), the RCFGAL register value must be negative. This causes the specified number of clock pulses to be subtracted from the timer counter, once every minute.
  - b) If the oscillator is slower than ideal (positive result from Step 2), the RCFGAL register value must be positive. This causes the specified number of clock pulses to be subtracted from the timer counter, once every minute.

Divide the number of error clocks, per minute by 4, to get the correct calibration value and load the RCFGAL register with the correct value. (Each 1-bit increment in the calibration adds or subtracts 4 pulses).

### EQUATION 19-1:

$$\frac{(\text{Ideal Frequency} \uparrow - \text{Measured Frequency}) * 60}{\text{Clocks per Minute}} \\ \uparrow \text{ Ideal Frequency} = 32,768 \text{ Hz}$$

Writes to the lower half of the RCFGAL register should only occur when the timer is turned off, or immediately after the rising edge of the seconds pulse.

**Note:** It is up to the user to include in the error value, the initial error of the crystal; drift due to temperature and drift due to crystal aging.

## 19.4 Alarm

- Configurable from half second to one year
- Enabled using the ALRMEN bit (ALCFGRPT<15>)
- One-time alarm and repeat alarm options available

### 19.4.1 CONFIGURING THE ALARM

The alarm feature is enabled using the ALRMEN bit. This bit is cleared when an alarm is issued. Writes to ALRMVAL should only take place when ALRMEN = 0.

As displayed in [Figure 19-2](#), the interval selection of the alarm is configured through the AMASK bits (ALCFGRPT<13:10>). These bits determine which and how many digits of the alarm must match the clock value for the alarm to occur.

The alarm can also be configured to repeat based on a preconfigured interval. The amount of times this occurs, once the alarm is enabled, is stored in the ARPT<7:0> bits (ALCFGRPT<7:0>). When the value of the ARPT bits equals 00h and the CHIME bit (ALCFGRPT<14>) is cleared, the repeat function is disabled and only a single alarm will occur. The alarm can be repeated, up to 255 times, by loading ARPT<7:0> with FFh.

After each alarm is issued, the value of the ARPT bits is decremented by one. Once the value has reached 00h, the alarm will be issued one last time, after which, the ALRMEN bit will be cleared automatically and the alarm will turn off.

Indefinite repetition of the alarm can occur if the CHIME bit = 1. Instead of the alarm being disabled when the value of the ARPT bits reaches 00h, it rolls over to FFh and continues counting indefinitely while CHIME is set.

### 19.4.2 ALARM INTERRUPT

At every alarm event, an interrupt is generated. In addition, an alarm pulse output is provided that operates at half the frequency of the alarm. This output is completely synchronous to the RTCC clock and can be used as a trigger clock to other peripherals.

**Note:** Changing any of the registers, other than the RCFGAL and ALCFGRPT registers, and the CHIME bit while the alarm is enabled (ALRMEN = 1), can result in a false alarm event leading to a false alarm interrupt. To avoid a false alarm event, the timer and alarm values should only be changed while the alarm is disabled (ALRMEN = 0). It is recommended that the ALCFGRPT register and the CHIME bit be changed when RTCSYNC = 0.

# PIC24F16KA102 FAMILY

**FIGURE 19-2: ALARM MASK SETTINGS**

Alarm Mask Setting (AMASK<3:0>)	Day of the Week	Month	Day	Hours	Minutes	Seconds
0000 - Every half second 0001 - Every second	<input type="checkbox"/>	<input type="checkbox"/> <input type="checkbox"/>	/ <input type="checkbox"/> <input type="checkbox"/>	<input type="checkbox"/> <input type="checkbox"/> : <input type="checkbox"/> <input type="checkbox"/> : <input type="checkbox"/> <input type="checkbox"/>		
0010 - Every 10 seconds	<input type="checkbox"/>	<input type="checkbox"/> <input type="checkbox"/>	/ <input type="checkbox"/> <input type="checkbox"/>	<input type="checkbox"/> <input type="checkbox"/> : <input type="checkbox"/> <input type="checkbox"/> : <input type="checkbox"/> <input type="checkbox"/>		<input type="checkbox"/> s
0011 - Every minute	<input type="checkbox"/>	<input type="checkbox"/> <input type="checkbox"/>	/ <input type="checkbox"/> <input type="checkbox"/>	<input type="checkbox"/> <input type="checkbox"/> : <input type="checkbox"/> <input type="checkbox"/> : <input type="checkbox"/> <input type="checkbox"/>		<input type="checkbox"/> s <input type="checkbox"/> s
0100 - Every 10 minutes	<input type="checkbox"/>	<input type="checkbox"/> <input type="checkbox"/>	/ <input type="checkbox"/> <input type="checkbox"/>	<input type="checkbox"/> <input type="checkbox"/> : <input type="checkbox"/> m : <input type="checkbox"/> <input type="checkbox"/>		<input type="checkbox"/> s <input type="checkbox"/> s
0101 - Every hour	<input type="checkbox"/>	<input type="checkbox"/> <input type="checkbox"/>	/ <input type="checkbox"/> <input type="checkbox"/>	<input type="checkbox"/> <input type="checkbox"/> : m m : <input type="checkbox"/> <input type="checkbox"/>		<input type="checkbox"/> s <input type="checkbox"/> s
0110 - Every day	<input type="checkbox"/>	<input type="checkbox"/> <input type="checkbox"/>	/ <input type="checkbox"/> <input type="checkbox"/>	h h : m m : <input type="checkbox"/> <input type="checkbox"/>		<input type="checkbox"/> s <input type="checkbox"/> s
0111 - Every week	<input checked="" type="checkbox"/> d	<input type="checkbox"/> <input type="checkbox"/>	/ <input type="checkbox"/> <input type="checkbox"/>	h h : m m : <input type="checkbox"/> <input type="checkbox"/>		<input type="checkbox"/> s <input type="checkbox"/> s
1000 - Every month	<input type="checkbox"/>	<input type="checkbox"/> <input type="checkbox"/>	/d d	h h : m m : <input type="checkbox"/> <input type="checkbox"/>		<input type="checkbox"/> s <input type="checkbox"/> s
1001 - Every year <sup>(1)</sup>	<input type="checkbox"/>	m m	/d d	h h : m m : <input type="checkbox"/> <input type="checkbox"/>		<input type="checkbox"/> s <input type="checkbox"/> s

**Note 1:** Annually, except when configured for February 29.

# PIC24F16KA102 FAMILY

---

NOTES:

## 20.0 PROGRAMMABLE CYCLIC REDUNDANCY CHECK (CRC) GENERATOR

**Note:** This data sheet summarizes the features of this group of PIC24F devices. It is not intended to be a comprehensive reference source. For more information on Programmable Cyclic Redundancy Check, refer to the "PIC24F Family Reference Manual", Section 30. "Programmable Cyclic Redundancy Check (CRC)" (DS39714).

The programmable Cyclic Redundancy Check (CRC) module in PIC24F devices is a software-configurable CRC checksum generator. The CRC algorithm treats a message as a binary bit stream and divides it by a fixed binary number.

The remainder from this division is considered the checksum. As in division, the CRC calculation is also an iterative process. The only difference is that these operations are done on modulo arithmetic based on mod2. For example, division is replaced with the XOR operation (i.e., subtraction without carry). The CRC algorithm uses the term, polynomial, to perform all of its calculations.

The divisor, dividend and remainder that are represented by numbers are termed as polynomials with binary coefficients.

The programmable CRC generator offers the following features:

- User-programmable polynomial CRC equation
- Interrupt output
- Data FIFO

The module implements a software-configurable CRC generator. The terms of the polynomial and its length can be programmed using the CRCXOR (X<15:1>) bits and the CRCCON (PLEN<3:0>) bits, respectively. Consider the CRC equation:

**EQUATION 20-1: CRC**

$$x^{16} + x^{12} + x^5 + 1$$

To program this polynomial into the CRC generator, the CRC register bits should be set as provided in [Table 20-1](#).

**TABLE 20-1: EXAMPLE CRC SETUP**

Bit Name	Bit Value
PLEN<3:0>	1111
X<15:1>	000100000010000

The value of X<15:1>, the 12<sup>th</sup> bit and the 5<sup>th</sup> bit are set to '1', as required by the equation. The 0 bit required by the equation is always XORed. For a 16-bit polynomial, the 16<sup>th</sup> bit is also always assumed to be XORed; therefore, the X<15:1> bits do not have the 0 bit or the 16<sup>th</sup> bit.

The topology of a standard CRC generator is displayed in [Figure 20-2](#).

**FIGURE 20-1: CRC SHIFTER DETAILS**

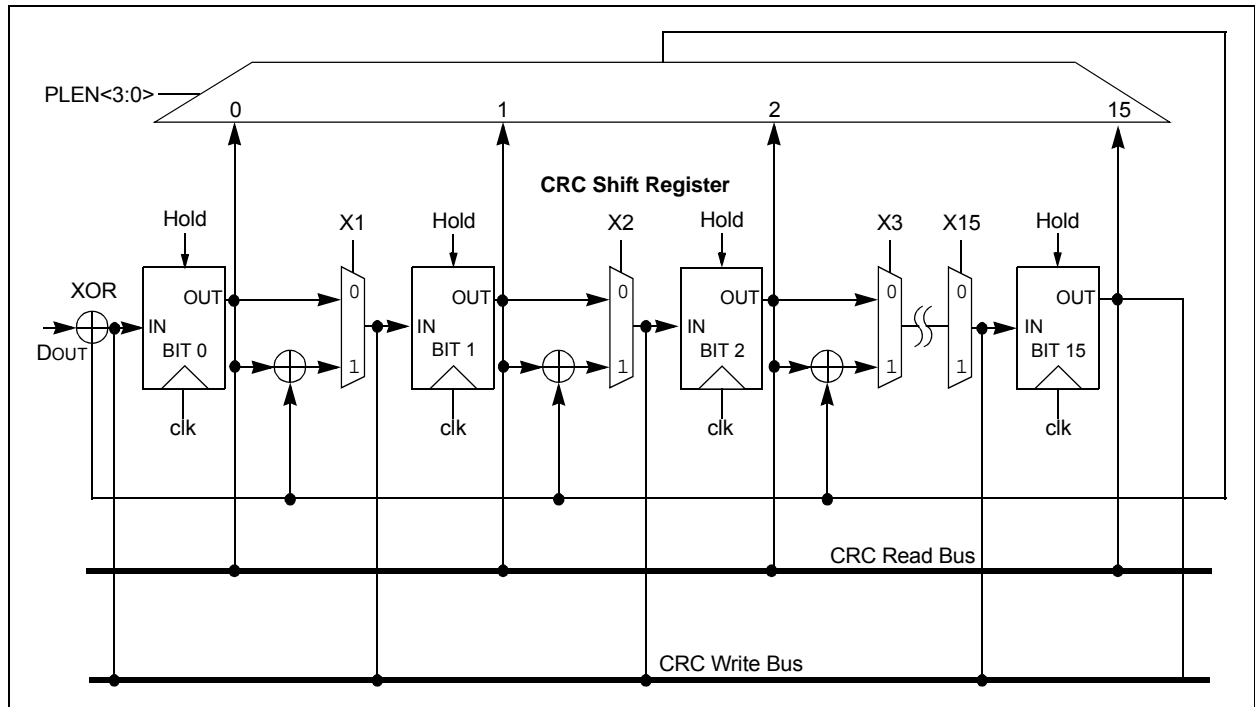

# PIC24F16KA102 FAMILY

**FIGURE 20-2: CRC GENERATOR RECONFIGURED FOR  $x^{16} + x^{12} + x^5 + 1$**



## 20.1 User Interface

### 20.1.1 DATA INTERFACE

To start serial shifting, a value of '1' must be written to the CRCGO bit.

The module incorporates a FIFO that is 8-level deep when  $PLEN < 3:0 > > 7$  and 16-deep, otherwise. The data for which the CRC is to be calculated must first be written into the FIFO. The smallest data element that can be written into the FIFO is one byte.

For example, if  $PLEN = 5$ , then the size of the data is  $PLEN + 1 = 6$ . The data must be written as follows:

```
data<5:0> = crc_input<5:0>
data<7:6> = bxx
```

Once data is written into the CRCWDAT MSb (as defined by  $PLEN$ ), the value of the VWORD bits ( $CRCCON < 12:8 >$ ) increments by one. The serial shifter starts shifting data into the CRC engine when  $CRCGO = 1$  and  $VWORD < 4:0 > > 0$ . When the Most Significant bit (MSb) is shifted out, the VWORD bits decrement by one. The serial shifter continues shifting until the VWORD bits reach zero. Therefore, for a given value of  $PLEN$ , it will take  $(PLEN + 1) * VWORD$  number of clock cycles to complete the CRC calculations.

When the VWORD bits reach 8 (or 16), the CRCFUL bit will be set. When the VWORD bits reach 0, the CRCMPT bit will be set.

To continually feed data into the CRC engine, the recommended mode of operation is to initially "prime" the FIFO with a sufficient number of words so no interrupt is generated before the next word can be written. Once that is done, start the CRC by setting the CRCGO bit to '1'. From that point onward, the VWORD bits should be polled. If they read less than 8 or 16, another word can be written into the FIFO.

To empty words already written into a FIFO, the CRCGO bit must be set to '1' and the CRC shifter allowed to run until the CRCMPT bit is set.

Also, to get the correct CRC reading, it will be necessary to wait for the CRCMPT bit to go high before reading the CRCWDAT register.

If a word is written when the CRCFUL bit is set, the VWORD Pointer will roll over to 0. The hardware will then behave as if the FIFO is empty. However, the condition to generate an interrupt will not be met; therefore, no interrupt will be generated (see [Section 20.1.2 "Interrupt Operation"](#)).

At least one instruction cycle must pass after a write to CRCWDAT before a read of the VWORD bits is done.

### 20.1.2 INTERRUPT OPERATION

When the  $VWORD < 4:0 >$  bits make a transition from a value of '1' to '0', an interrupt will be generated.

## 20.2 Operation in Power Save Modes

### 20.2.1 SLEEP MODE

If Sleep mode is entered while the module is operating, the module will be suspended in its current state until clock execution resumes.

### 20.2.2 IDLE MODE

To continue full module operation in Idle mode, the CSIDL bit must be cleared prior to entry into the mode.

If  $CSIDL = 1$ , the module will behave the same way as it does in Sleep mode; pending interrupt events will be passed on, even though the module clocks are not available.



# PIC24F16KA102 FAMILY

## 20.3 Registers

There are four registers used to control programmable CRC operation:

- CRCCON
- CRCXOR
- CRCDAT
- CRCWDAT

### REGISTER 20-1: CRCCON: CRC CONTROL REGISTER

U-0	U-0	R/W-0	R-0, HSC	R-0, HSC	R-0, HSC	R-0, HSC	R-0, HSC
—	—	CSIDL	VWORD4	VWORD3	VWORD2	VWORD1	VWORD0
bit 15							bit 8

R-0, HSC	R-1, HSC	U-0	R/W-0	R/W-0	R/W-0	R/W-0	R/W-0
CRCFUL	CRCMPT	—	CRCGO	PLEN3	PLEN2	PLEN1	PLEN0
bit 7							bit 0

<b>Legend:</b>	HSC = Hardware Settable/Clearable bit
R = Readable bit	W = Writable bit
-n = Value at POR	'1' = Bit is set
	'0' = Bit is cleared
	x = Bit is unknown
	U = Unimplemented bit, read as '0'

bit 15-14 **Unimplemented:** Read as '0'

bit 13 **CSIDL:** CRC Stop in Idle Mode bit

- 1 = Discontinue module operation when device enters Idle mode
- 0 = Continue module operation in Idle mode

bit 12-8 **VWORD<4:0>:** Pointer Value bits

Indicates the number of valid words in the FIFO. Has a maximum value of 8 when PLEN<3:0> > 7, or 16 when PLEN<3:0> ≤ 7.

bit 7 **CRCFUL:** FIFO Full bit

- 1 = FIFO is full
- 0 = FIFO is not full

bit 6 **CRCMPT:** FIFO Empty Bit

- 1 = FIFO is empty
- 0 = FIFO is not empty

bit 5 **Unimplemented:** Read as '0'

bit 4 **CRCGO:** Start CRC bit

- 1 = Start CRC serial shifter
- 0 = CRC serial shifter is turned off

bit 3-0 **PLEN<3:0>:** Polynomial Length bits

Denotes the length of the polynomial to be generated minus 1.

# PIC24F16KA102 FAMILY

## REGISTER 20-2: CRCXOR: CRC XOR POLYNOMIAL REGISTER

R/W-0	R/W-0	R/W-0	R/W-0	R/W-0	R/W-0	R/W-0	R/W-0
X15	X14	X13	X12	X11	X10	X9	X8
bit 15							bit 8

R/W-0	R/W-0	R/W-0	R/W-0	R/W-0	R/W-0	R/W-0	U-0
X7	X6	X5	X4	X3	X2	X1	—
bit 7							bit 0

### Legend:

R = Readable bit	W = Writable bit	U = Unimplemented bit, read as '0'
-n = Value at POR	'1' = Bit is set	'0' = Bit is cleared      x = Bit is unknown

bit 15-1      **X<15:1>**: XOR of Polynomial Term  $X^n$  Enable bits

bit 0      **Unimplemented:** Read as '0'

## 21.0 HIGH/LOW-VOLTAGE DETECT (HLVD)

**Note:** This data sheet summarizes the features of this group of PIC24F devices. It is not intended to be a comprehensive reference source. For more information on the High/Low-Voltage Detect, refer to the “PIC24F Family Reference Manual”, Section 36. “High-Level Integration with Programmable High/Low-Voltage Detect (HLVD)” (DS39725).

An interrupt flag is set if the device experiences an excursion past the trip point in the direction of change. If the interrupt is enabled, the program execution will branch to the interrupt vector address and the software can then respond to the interrupt.

The HLVD Control register (see [Register 21-1](#)) completely controls the operation of the HLVD module. This allows the circuitry to be “turned off” by the user under software control, which minimizes the current consumption for the device.

The High/Low-Voltage Detect module (HLVD) is a programmable circuit that allows the user to specify both the device voltage trip point and the direction of change.

**FIGURE 21-1: HIGH/LOW-VOLTAGE DETECT (HLVD) MODULE BLOCK DIAGRAM**



# PIC24F16KA102 FAMILY

## REGISTER 21-1: HLVDCON: HIGH/LOW-VOLTAGE DETECT CONTROL REGISTER

R/W-0	U-0	R/W-0	U-0	U-0	U-0	U-0	U-0
HLVDEN	—	HLSIDL	—	—	—	—	—
bit 15							bit 8

R/W-0	R/W-0	R/W-0	U-0	R/W-0	R/W-0	R/W-0	R/W-0
VDIR	BGVST	IRVST	—	HLVDL3	HLVDL2	HLVDL1	HLVDL0
bit 7							bit 0

### Legend:

R = Readable bit                      W = Writable bit                      U = Unimplemented bit, read as '0'  
 -n = Value at POR                      '1' = Bit is set                      '0' = Bit is cleared                      x = Bit is unknown

- bit 15            **HLVDEN:** High/Low-Voltage Detect Power Enable bit  
                   1 = HLVD is enabled  
                   0 = HLVD is disabled
- bit 14            **Unimplemented:** Read as '0'
- bit 13            **HLSIDL:** HLVD Stop in Idle Mode bit  
                   1 = Discontinue module operation when device enters Idle mode  
                   0 = Continue module operation in Idle mode
- bit 12-8        **Unimplemented:** Read as '0'
- bit 7            **VDIR:** Voltage Change Direction Select bit  
                   1 = Event occurs when voltage equals or exceeds trip point (HLVDL<3:0>)  
                   0 = Event occurs when voltage equals or falls below trip point (HLVDL<3:0>)
- bit 6            **BGVST:** Band Gap Voltage Stable Flag bit  
                   1 = Indicates that the band gap voltage is stable  
                   0 = Indicates that the band gap voltage is unstable
- bit 5            **IRVST:** Internal Reference Voltage Stable Flag bit  
                   1 = Indicates that the internal reference voltage is stable and the High-Voltage Detect logic generates the interrupt flag at the specified voltage range  
                   0 = Indicates that the internal reference voltage is unstable and the High-Voltage Detect logic will not generate the interrupt flag at the specified voltage range, and the HLVD interrupt should not be enabled
- bit 4            **Unimplemented:** Read as '0'
- bit 3-0        **HLVDL<3:0>:** High/Low-Voltage Detection Limit bits  
                   1111 = External analog input is used (input comes from the HLVDIN pin)  
                   1110 = Trip Point 1<sup>(1)</sup>  
                   1101 = Trip Point 2<sup>(1)</sup>  
                   1100 = Trip Point 3<sup>(1)</sup>  
                   .  
                   .  
                   .  
                   0000 = Trip Point 15<sup>(1)</sup>

**Note 1:** For actual trip point, refer to [Section 29.0 “Electrical Characteristics”](#).

## 22.0 10-BIT HIGH-SPEED A/D CONVERTER

**Note:** This data sheet summarizes the features of this group of PIC24F devices. It is not intended to be a comprehensive reference source. For more information on the 10-Bit High-Speed A/D Converter, refer to the “PIC24F Family Reference Manual”, **Section 17. “10-Bit A/D Converter”** (DS39705).

The 10-bit A/D Converter has the following key features:

- Successive Approximation (SAR) conversion
- Conversion speeds of up to 500 ksps
- Nine analog input pins
- External voltage reference input pins
- Internal band gap reference inputs
- Automatic Channel Scan mode
- Selectable conversion trigger source
- 16-word conversion result buffer
- Selectable Buffer Fill modes
- Four result alignment options
- Operation During CPU Sleep and Idle modes

On all PIC24F16KA102 family devices, the 10-bit A/D Converter has nine analog input pins, designated AN0 through AN5 and AN10 through AN12. In addition, there are two analog input pins for external voltage reference connections (VREF+ and VREF-). These voltage reference inputs may be shared with other analog input pins.

A block diagram of the A/D Converter is displayed in [Figure 22-1](#).

To perform an A/D conversion:

1. Configure the A/D module:
  - a) Configure port pins as analog inputs and/or select band gap reference inputs (AD1PCFG<15:13>, AD1PCFG<9:6>).
  - b) Select voltage reference source to match expected range on analog inputs (AD1CON2<15:13>).
  - c) Select the analog conversion clock to match the desired data rate with the processor clock (AD1CON3<7:0>).
  - d) Select the appropriate sample/conversion sequence (AD1CON1<7:5> and AD1CON3<12:8>).
  - e) Select how conversion results are presented in the buffer (AD1CON1<9:8>).
  - f) Select interrupt rate (AD1CON2<5:2>).
  - g) Turn on A/D module (AD1CON1<15>).
2. Configure A/D interrupt (if required):
  - a) Clear the AD1IF bit.
  - b) Select A/D interrupt priority.

# PIC24F16KA102 FAMILY

**FIGURE 22-1: 10-BIT HIGH-SPEED A/D CONVERTER BLOCK DIAGRAM**



# PIC24F16KA102 FAMILY

## REGISTER 22-1: AD1CON1: A/D CONTROL REGISTER 1

R/W-0	U-0	R/W-0	U-0	U-0	U-0	R/W-0	R/W-0
ADON <sup>(1)</sup>	—	ADSIDL	—	—	—	FORM1	FORM0
bit 15						bit 8	

R/W-0	R/W-0	R/W-0	U-0	U-0	R/W-0	R/W-0, HSC	R/W-0, HSC
SSRC2	SSRC1	SSRC0	—	—	ASAM	SAMP	DONE
bit 7						bit 0	

<b>Legend:</b>	HSC = Hardware Settable/Clearable bit		
R = Readable bit	W = Writable bit	U = Unimplemented bit, read as '0'	
-n = Value at POR	'1' = Bit is set	'0' = Bit is cleared	x = Bit is unknown

- bit 15     **ADON:** A/D Operating Mode bit<sup>(1)</sup>  
           1 = A/D Converter module is operating  
           0 = A/D Converter is off
- bit 14     **Unimplemented:** Read as '0'
- bit 13     **ADSIDL:** Stop in Idle Mode bit  
           1 = Discontinue module operation when device enters Idle mode  
           0 = Continue module operation in Idle mode
- bit 12-10   **Unimplemented:** Read as '0'
- bit 9-8     **FORM<1:0>:** Data Output Format bits  
           11 = Signed fractional (sddd dddd dd00 0000)  
           10 = Fractional (dddd dddd dd00 0000)  
           01 = Signed integer (ssss sssd dddd dddd)  
           00 = Integer (0000 00dd dddd dddd)
- bit 7-5     **SSRC<2:0>:** Conversion Trigger Source Select bits  
           111 = Internal counter ends sampling and starts conversion (auto-convert)  
           110 = CTMU event ends sampling and starts conversion  
           101 = Reserved  
           100 = Reserved  
           011 = Reserved  
           010 = Timer3 compare ends sampling and starts conversion  
           001 = Active transition on INT0 pin ends sampling and starts conversion  
           000 = Clearing SAMP bit ends sampling and starts conversion
- bit 4-3     **Unimplemented:** Read as '0'
- bit 2       **ASAM:** A/D Sample Auto-Start bit  
           1 = Sampling begins immediately after last conversion completes; SAMP bit is auto-set  
           0 = Sampling begins when SAMP bit is set
- bit 1       **SAMP:** A/D Sample Enable bit  
           1 = A/D sample/hold amplifier is sampling input  
           0 = A/D sample/hold amplifier is holding
- bit 0       **DONE:** A/D Conversion Status bit  
           1 = A/D conversion is done  
           0 = A/D conversion is not done

**Note 1:** Values of ADC1BUF<sub>n</sub> registers will not retain their values once the ADON bit is cleared. Read out the conversion values from the buffer before disabling the module.

# PIC24F16KA102 FAMILY

## REGISTER 22-2: AD1CON2: A/D CONTROL REGISTER 2

R/W-0	R/W-0	R/W-0	R/W-0	U-0	R/W-0	U-0	U-0
VCFG2	VCFG1	VCFG0	OFFCAL <sup>(1)</sup>	—	CSCNA	—	—
bit 15							bit 8

R-0, HSC	U-0	R/W-0	R/W-0	R/W-0	R/W-0	R/W-0	R/W-0
BUFS	—	SMPI3	SMPI2	SMPI1	SMPI0	BUFM	ALTS
bit 7							bit 0

<b>Legend:</b>	HSC = Hardware Settable/Clearable bit
R = Readable bit	W = Writable bit
-n = Value at POR	'1' = Bit is set
	U = Unimplemented bit, read as '0'
	'0' = Bit is cleared
	x = Bit is unknown

bit 15-13 **VCFG<2:0>**: Voltage Reference Configuration bits

VCFG<2:0>	VR+	VR-
000	AVDD	AVSS
001	External VREF+ pin	AVSS
010	AVDD	External VREF- pin
011	External VREF+ pin	External VREF- pin
1xx	AVDD	AVSS

bit 12 **OFFCAL**: Offset Calibration bit<sup>(1)</sup>

1 = Converts to get the offset calibration value  
0 = Converts to get the actual input value

bit 11 **Unimplemented**: Read as '0'

bit 10 **CSCNA**: Scan Input Selections for CH0+ S/H Input for MUX A Input Multiplexer Setting bit

1 = Scan inputs  
0 = Do not scan inputs

bit 9-8 **Unimplemented**: Read as '0'

bit 7 **BUFS**: Buffer Fill Status bit (valid only when BUFM = 1)

1 = A/D is currently filling buffer, 08-0F; user should access data in 00-07  
0 = A/D is currently filling buffer, 00-07; user should access data in 08-0F

bit 6 **Unimplemented**: Read as '0'

bit 5-2 **SMPI<3:0>**: Sample/Convert Sequences Per Interrupt Selection bits

1111 = Interrupts at the completion of conversion for each 16<sup>th</sup> sample/convert sequence  
1110 = Interrupts at the completion of conversion for each 15<sup>th</sup> sample/convert sequence  
.  
.  
.  
0001 = Interrupts at the completion of conversion for each 2<sup>nd</sup> sample/convert sequence  
0000 = Interrupts at the completion of conversion for each sample/convert sequence

**Note 1:** When the OFFCAL bit is set, inputs are disconnected and tied to AVSS. This sets the inputs of the A/D to zero. Then, the user can perform a conversion. Use of the Calibration mode is not affected by AD1PCFG contents nor channel input selection. Any analog input switches are disconnected from the A/D Converter in this mode. The conversion result is stored by the user software and used to compensate subsequent conversions. This can be done by adding the two's complement of the result obtained with the OFFCAL bit set to all normal A/D conversions.



# PIC24F16KA102 FAMILY

## REGISTER 22-2: AD1CON2: A/D CONTROL REGISTER 2 (CONTINUED)

- bit 1      **BUFm**: Buffer Mode Select bit  
           1 = Buffer is configured as two 8-word buffers (ADC1BUFn<15:8> and ADC1BUFn<7:0>)  
           0 = Buffer is configured as one 16-word buffer (ADC1BUFn<15:0>)
- bit 0      **ALTS**: Alternate Input Sample Mode Select bit  
           1 = Uses MUX A input multiplexer settings for first sample, then alternates between MUX B and  
               MUX A input multiplexer settings for all subsequent samples  
           0 = Always uses MUX A input multiplexer settings

**Note 1:** When the OFFCAL bit is set, inputs are disconnected and tied to AVss. This sets the inputs of the A/D to zero. Then, the user can perform a conversion. Use of the Calibration mode is not affected by AD1PCFG contents nor channel input selection. Any analog input switches are disconnected from the A/D Converter in this mode. The conversion result is stored by the user software and used to compensate subsequent conversions. This can be done by adding the two's complement of the result obtained with the OFFCAL bit set to all normal A/D conversions.

## REGISTER 22-3: AD1CON3: A/D CONTROL REGISTER 3

R/W-0	U-0	U-0	R/W-0	R/W-0	R/W-0	R/W-0	R/W-0
ADRC	—	—	SAMC4	SAMC3	SAMC2	SAMC1	SAMC0
bit 15							bit 8

U-0	U-0	R/W-0	R/W-0	R/W-0	R/W-0	R/W-0	R/W-0
—	—	ADCS5	ADCS4	ADCS3	ADCS2	ADCS1	ADCS0
bit 7							bit 0

### Legend:

R = Readable bit	W = Writable bit	U = Unimplemented bit, read as '0'
-n = Value at POR	'1' = Bit is set	'0' = Bit is cleared      x = Bit is unknown

- bit 15      **ADRC**: A/D Conversion Clock Source bit  
           1 = A/D internal RC clock  
           0 = Clock derived from system clock
- bit 14-13   **Unimplemented**: Read as '0'
- bit 12-8    **SAMC<4:0>**: Auto-Sample Time bits  
           11111 = 31 TAD  
           .  
           .  
           .  
           00001 = 1 TAD  
           00000 = 0 TAD (not recommended)
- bit 7-6     **Unimplemented**: Read as '0'
- bit 5-0     **ADCS<5:0>**: A/D Conversion Clock Select bits  
           111111 = 64 • Tcy  
           111110 = 63 • Tcy  
           .  
           .  
           .  
           000001 = 3 • Tcy  
           000000 = 2 • Tcy

# PIC24F16KA102 FAMILY

**REGISTER 22-4: AD1CHS: A/D INPUT SELECT REGISTER**

R/W-0	U-0	U-0	U-0	R/W-0	R/W-0	R/W-0	R/W-0
CH0NB	—	—	—	CH0SB3	CH0SB2	CH0SB1	CH0SB0
bit 15							bit 8

R/W-0	U-0	U-0	U-0	R/W-0	R/W-0	R/W-0	R/W-0
CH0NA	—	—	—	CH0SA3	CH0SA2	CH0SA1	CH0SA0
bit 7							bit 0

**Legend:**

R = Readable bit	W = Writable bit	U = Unimplemented bit, read as '0'
-n = Value at POR	'1' = Bit is set	'0' = Bit is cleared
		x = Bit is unknown

- bit 15      **CH0NB:** Channel 0 Negative Input Select for MUX B Multiplexer Setting bit  
             1 = Channel 0 negative input is AN1  
             0 = Channel 0 negative input is VR-
- bit 14-12    **Unimplemented:** Read as '0'
- bit 11-8    **CH0SB<3:0>:** Channel 0 Positive Input Select for MUX B Multiplexer Setting bits  
             1111 = Channel 0 positive input is band gap reference (V<sub>BG</sub>)  
             1110 = Channel 0 positive input is band gap, divided by two, reference (V<sub>BG</sub>/2)  
             1101 = No channels connected (actual A/D MUX switch activates, but input floats); used for CTMU  
             1100 = Channel 0 positive input is AN12  
             1011 = Channel 0 positive input is AN11  
             1010 = Channel 0 positive input is AN10  
             1001 = Reserved  
             1000 = Reserved  
             0111 = AV<sub>DD</sub>  
             0110 = AV<sub>SS</sub>  
             0101 = Channel 0 positive input is AN5  
             0100 = Channel 0 positive input is AN4  
             0011 = Channel 0 positive input is AN3  
             0010 = Channel 0 positive input is AN2  
             0001 = Channel 0 positive input is AN1  
             0000 = Channel 0 positive input is AN0
- bit 7        **CH0NA:** Channel 0 Negative Input Select for MUX A Multiplexer Setting bit  
             1 = Channel 0 negative input is AN1  
             0 = Channel 0 negative input is VR-
- bit 6-4     **Unimplemented:** Read as '0'
- bit 3-0     **CH0SA<3:0>:** Channel 0 Positive Input Select for Sample A bits  
             1111 = Channel 0 positive input is band gap reference (V<sub>BG</sub>)  
             1110 = Channel 0 positive input is band gap, divided by two, reference (V<sub>BG</sub>/2)  
             1101 = No channels connected (actual A/D MUX switch activates but input floats); used for CTMU  
             1100 = Channel 0 positive input is AN12  
             1011 = Channel 0 positive input is AN11  
             1010 = Channel 0 positive input is AN10  
             1001 = Reserved  
             1000 = Reserved  
             0111 = AV<sub>DD</sub>  
             0110 = AV<sub>SS</sub>  
             0101 = Channel 0 positive input is AN5  
             0100 = Channel 0 positive input is AN4  
             0011 = Channel 0 positive input is AN3  
             0010 = Channel 0 positive input is AN2  
             0001 = Channel 0 positive input is AN1  
             0000 = Channel 0 positive input is AN0

# PIC24F16KA102 FAMILY

## REGISTER 22-5: AD1PCFG: A/D PORT CONFIGURATION REGISTER

R/W-0	R/W-0	U-0	R/W-0	R/W-0	R/W-0	U-0	U-0
PCFG15	PCFG14	—	PCFG12	PCFG11	PCFG10	—	—
bit 15							bit 8

U-0	U-0	R/W-0	R/W-0	R/W-0	R/W-0	R/W-0	R/W-0
—	—	PCFG5	PCFG4	PCFG3	PCFG2	PCFG1	PCFG0
bit 7							bit 0

### Legend:

R = Readable bit

W = Writable bit

U = Unimplemented bit, read as '0'

-n = Value at POR

'1' = Bit is set

'0' = Bit is cleared

x = Bit is unknown

- bit 15      **PCFG15:** Analog Input Pin Configuration Control bit  
 1 = Analog channel is disabled from input scan  
 0 = Internal band gap (V<sub>BG</sub>) channel is enabled for input scan
- bit 14      **PCFG14:** Analog Input Pin Configuration Control bit  
 1 = Analog channel is disabled from input scan  
 0 = Internal V<sub>BG</sub>/2 channel is enabled for input scan
- bit 13      **Unimplemented:** Read as '0'
- bit 12-10   **PCFG<12:10>:** Analog Input Pin Configuration Control bits  
 1 = Pin for corresponding analog channel is configured in Digital mode; I/O port read is enabled  
 0 = Pin is configured in Analog mode; I/O port read is disabled; A/D samples pin voltage
- bit 9-6     **Unimplemented:** Read as '0'
- bit 5-0     **PCFG<5:0>:** Analog Input Pin Configuration Control bits  
 1 = Pin for corresponding analog channel is configured in Digital mode; I/O port read is enabled  
 0 = Pin configured in Analog mode; I/O port read is disabled; A/D samples pin voltage

# PIC24F16KA102 FAMILY

## REGISTER 22-6: AD1CSSL: A/D INPUT SCAN SELECT REGISTER (LOW)

U-0	U-0	U-0	R/W-0	R/W-0	R/W-0	U-0	U-0
—	—	—	CSSL12	CSSL11	CSSL10	—	—
bit 15						bit 8	

U-0	U-0	R/W-0	R/W-0	R/W-0	R/W-0	R/W-0	R/W-0
—	—	CSSL5	CSSL4	CSSL3	CSSL2	CSSL1	CSSL0
bit 7						bit 0	

### Legend:

R = Readable bit

W = Writable bit

U = Unimplemented bit, read as '0'

-n = Value at POR

'1' = Bit is set

'0' = Bit is cleared

x = Bit is unknown

bit 15-13 **Unimplemented:** Read as '0'

bit 12-10 **CSSL<12:10>:** A/D Input Pin Scan Selection bits

1 = Corresponding analog channel is selected for input scan

0 = Analog channel omitted from input scan

bit 9-6 **Unimplemented:** Read as '0'

bit 5-0 **CSSL<5:0>:** A/D Input Pin Scan Selection bits

1 = Corresponding analog channel is selected for input scan

0 = Analog channel omitted from input scan

# PIC24F16KA102 FAMILY

**EQUATION 22-1: A/D CONVERSION CLOCK PERIOD<sup>(1)</sup>**

$$ADCS = \frac{T_{AD}}{T_{CY}} - 1$$

$$T_{AD} = T_{CY} \cdot (ADCS + 1)$$

**Note 1:** Based on  $T_{CY} = 2 \cdot T_{OSC}$ ; Doze mode and PLL are disabled.

**FIGURE 22-2: 10-BIT A/D CONVERTER ANALOG INPUT MODEL**



<b>Legend:</b>	CPIN	= Input Capacitance
	VT	= Threshold Voltage
	ILEAKAGE	= Leakage Current at the pin due to various junctions
	RIC	= Interconnect Resistance
	Rss	= Sampling Switch Resistance
	CHOLD	= Sample/Hold Capacitance (from A/D)

**Note:** CPIN value depends on device package and is not tested. Effect of CPIN negligible if  $R_s \leq 5 \text{ k}\Omega$ .

# PIC24F16KA102 FAMILY

FIGURE 22-3: A/D TRANSFER FUNCTION



## 23.0 COMPARATOR MODULE

**Note:** This data sheet summarizes the features of this group of PIC24F devices. It is not intended to be a comprehensive reference source. For more information on the Comparator module, refer to the “PIC24F Family Reference Manual”, Section 46. “Scalable Comparator Module” (DS39734).

The comparator module provides two dual input comparators. The inputs to the comparator can be configured to use any one of four external analog inputs, as well as a voltage reference input from either the internal band gap reference, divided by 2 ( $V_{BG}/2$ ), or the comparator voltage reference generator.

The comparator outputs may be directly connected to the CxOUT pins. When the respective COE equals ‘1’, the I/O pad logic makes the unsynchronized output of the comparator available on the pin.

A simplified block diagram of the module is displayed in Figure 23-1. Diagrams of the possible individual comparator configurations are displayed in Figure 23-2.

Each comparator has its own control register, CMxCON (Register 23-1), for enabling and configuring its operation. The output and event status of all three comparators is provided in the CMSTAT register (Register 23-2).

**FIGURE 23-1: COMPARATOR MODULE BLOCK DIAGRAM**



# PIC24F16KA102 FAMILY

**FIGURE 23-2: INDIVIDUAL COMPARATOR CONFIGURATIONS**





# PIC24F16KA102 FAMILY

## REGISTER 23-1: CMxCON: COMPARATOR x CONTROL REGISTERS

R/W-0	R/W-0	R/W-0	R/W-0	U-0	U-0	R/W-0	R-0
CON	COE	CPOL	CLPWR	—	—	CEVT	COUT
bit 15							bit 8

R/W-0	R/W-0	U-0	R/W-0	U-0	U-0	R/W-0	R/W-0
EVPOL1	EVPOLO	—	CREF	—	—	CCH1	CCH0
bit 7							bit 0

### Legend:

R = Readable bit                      W = Writable bit                      U = Unimplemented bit, read as '0'  
 -n = Value at POR                      '1' = Bit is set                      '0' = Bit is cleared                      x = Bit is unknown

- bit 15        **CON:** Comparator Enable bit  
                   1 = Comparator is enabled  
                   0 = Comparator is disabled
- bit 14        **COE:** Comparator Output Enable bit  
                   1 = Comparator output is present on the CxOUT pin  
                   0 = Comparator output is internal only
- bit 13        **CPOL:** Comparator Output Polarity Select bit  
                   1 = Comparator output is inverted  
                   0 = Comparator output is not inverted
- bit 12        **CLPWR:** Comparator Low-Power Mode Select bit  
                   1 = Comparator operates in Low-Power mode  
                   0 = Comparator does not operate in Low-Power mode
- bit 11-10     **Unimplemented:** Read as '0'
- bit 9         **CEVT:** Comparator Event bit  
                   1 = Comparator event defined by EVPOL<1:0> has occurred; subsequent triggers and interrupts are disabled until the bit is cleared  
                   0 = Comparator event has not occurred
- bit 8         **COUT:** Comparator Output bit  
                   When CPOL = 0:  
                   1 =  $V_{IN+} > V_{IN-}$   
                   0 =  $V_{IN+} < V_{IN-}$   
                   When CPOL = 1:  
                   1 =  $V_{IN+} < V_{IN-}$   
                   0 =  $V_{IN+} > V_{IN-}$
- bit 7-6       **EVPOL<1:0>:** Trigger/Event/Interrupt Polarity Select bits  
                   11 = Trigger/event/interrupt is generated on any change of the comparator output (while CEVT = 0)  
                   10 = Trigger/event/interrupt is generated on transition of the comparator output:  
                       If CPOL = 0 (non-inverted polarity):  
                           High-to-low transition only.  
                       If CPOL = 1 (inverted polarity):  
                           Low-to-high transition only.  
                   01 = Trigger/event/interrupt is generated on transition of the comparator output:  
                       If CPOL = 0 (non-inverted polarity):  
                           Low-to-high transition only.  
                       If CPOL = 1 (inverted polarity):  
                           High-to-low transition only.  
                   00 = Trigger/event/interrupt generation is disabled

# PIC24F16KA102 FAMILY

## REGISTER 23-1: CMxCON: COMPARATOR x CONTROL REGISTERS (CONTINUED)

- bit 5      **Unimplemented:** Read as '0'
- bit 4      **CREF:** Comparator Reference Select bit (non-inverting input)  
 1 = Non-inverting input connects to the internal CVREF voltage  
 0 = Non-inverting input connects to the CxINA pin
- bit 3-2    **Unimplemented:** Read as '0'
- bit 1-0    **CCH<1:0>:** Comparator Channel Select bits  
 11 = Inverting input of comparator connects to VBG/2  
 10 = Inverting input of comparator connects to CxIND pin  
 01 = Inverting input of comparator connects to CxINC pin  
 00 = Inverting input of comparator connects to CxINB pin

## REGISTER 23-2: CMSTAT: COMPARATOR MODULE STATUS REGISTER

R/W-0	U-0	U-0	U-0	U-0	U-0	R-0, HSC	R-0, HSC
CMIDL	—	—	—	—	—	C2EVT	C1EVT
bit 15						bit 8	

U-0	U-0	U-0	U-0	U-0	U-0	R-0, HSC	R-0, HSC
—	—	—	—	—	—	C2OUT	C1OUT
bit 7						bit 0	

<b>Legend:</b>	HSC = Hardware Settable/Clearable bit		
R = Readable bit	W = Writable bit	U = Unimplemented bit, read as '0'	
-n = Value at POR	'1' = Bit is set	'0' = Bit is cleared	x = Bit is unknown

- bit 15      **CMIDL:** Comparator Stop in Idle Mode bit  
 1 = Disable comparator interrupts when the device enters Idle mode; the module is still enabled  
 0 = Continue operation of all enabled comparators in Idle mode
- bit 14-10   **Unimplemented:** Read as '0'
- bit 9      **C2EVT:** Comparator 2 Event Status bit (read-only)  
 Shows the current event status of Comparator 2 (CM2CON<9>).
- bit 8      **C1EVT:** Comparator 1 Event Status bit (read-only)  
 Shows the current event status of Comparator 1 (CM1CON<9>).
- bit 7-2    **Unimplemented:** Read as '0'
- bit 1      **C2OUT:** Comparator 2 Output Status bit (read-only)  
 Shows the current output of Comparator 2 (CM2CON<8>).
- bit 0      **C1OUT:** Comparator 1 Output Status bit (read-only)  
 Shows the current output of Comparator 1 (CM1CON<8>).

# PIC24F16KA102 FAMILY

## 24.0 COMPARATOR VOLTAGE REFERENCE

**Note:** This data sheet summarizes the features of this group of PIC24F devices. It is not intended to be a comprehensive reference source. For more information on the Comparator Voltage Reference, refer to the "PIC24F Family Reference Manual", Section 20. "Comparator Voltage Reference Module" (DS39709).

## 24.1 Configuring the Comparator Voltage Reference

The comparator voltage reference module is controlled through the CVRCON register (Register 24-1). The comparator voltage reference provides two ranges of output voltage, each with 16 distinct levels. The range to be used is selected by the CVRR bit (CVRCON<5>). The primary difference between the ranges is the size of the steps selected by the CVREF Selection bits (CVR<3:0>), with one range offering finer resolution.

The comparator reference supply voltage can come from either  $V_{DD}$  and  $V_{SS}$ , or the external  $V_{REF+}$  and  $V_{REF-}$ . The voltage source is selected by the CVRSS bit (CVRCON<4>).

The settling time of the comparator voltage reference must be considered when changing the CVREF output.

FIGURE 24-1: COMPARATOR VOLTAGE REFERENCE BLOCK DIAGRAM



# PIC24F16KA102 FAMILY

## REGISTER 24-1: CVRCON: COMPARATOR VOLTAGE REFERENCE CONTROL REGISTER

U-0	U-0	U-0	U-0	U-0	U-0	U-0	U-0
—	—	—	—	—	—	—	—
bit 15							bit 8

R/W-0	R/W-0	R/W-0	R/W-0	R/W-0	R/W-0	R/W-0	R/W-0
CVREN	CVROE	CVRR	CVRSS	CVR3	CVR2	CVR1	CVR0
bit 7							bit 0

### Legend:

R = Readable bit

W = Writable bit

U = Unimplemented bit, read as '0'

-n = Value at POR

'1' = Bit is set

'0' = Bit is cleared

x = Bit is unknown

bit 15-8 **Unimplemented:** Read as '0'

bit 7 **CVREN:** Comparator Voltage Reference Enable bit

1 = CVREF circuit is powered on

0 = CVREF circuit is powered down

bit 6 **CVROE:** Comparator VREF Output Enable bit

1 = CVREF voltage level is output on CVREF pin

0 = CVREF voltage level is disconnected from CVREF pin

bit 5 **CVRR:** Comparator VREF Range Selection bit

1 = CVRSRC range should be 0 to 0.625 CVRSRC with CVRSRC/24 step size

0 = CVRSRC range should be 0.25 to 0.719 CVRSRC with CVRSRC/32 step size

bit 4 **CVRSS:** Comparator VREF Source Selection bit

1 = Comparator reference source, CVRSRC = VREF+ – VREF-

0 = Comparator reference source, CVRSRC = AVDD – AVSS

bit 3-0 **CVR3:CVR0:** Comparator VREF Value Selection  $0 \leq \text{CVR}\langle 3:0 \rangle \leq 15$  bits

When CVRR = 1 and CVRSS = 0:

$$\text{CVREF} = (\text{CVR}\langle 3:0 \rangle / 24) * (\text{CVRSRC})$$

When CVRR = 0 and CVRSS = 0:

$$\text{CVREF} = 1/4 (\text{CVRSRC}) + (\text{CVR}\langle 3:0 \rangle / 32) * (\text{CVRSRC})$$

When CVRR = 1 and CVRSS = 1:

$$\text{CVREF} = ((\text{CVR}\langle 3:0 \rangle / 24) * (\text{CVRSRC})) + \text{VREF-}$$

When CVRR = 0 and CVRSS = 1:

$$\text{CVREF} = (1/4 (\text{CVRSRC}) + (\text{CVR}\langle 3:0 \rangle / 32) * (\text{CVRSRC})) + \text{VREF-}$$

## 25.0 CHARGE TIME MEASUREMENT UNIT (CTMU)

**Note:** This data sheet summarizes the features of this group of PIC24F devices. It is not intended to be a comprehensive reference source. For more information on the Charge Measurement Unit, refer to the “PIC24F Family Reference Manual”, Section 11. “Charge Time Measurement Unit (CTMU)” (DS39724).

The Charge Time Measurement Unit (CTMU) is a flexible analog module that provides charge measurement, accurate differential time measurement between pulse sources and asynchronous pulse generation. Its key features include:

- Four-edge input trigger sources
- Polarity control for each edge source
- Control of edge sequence
- Control of response to edges
- Time measurement resolution of one nanosecond
- Accurate current source suitable for capacitive measurement

Together with other on-chip analog modules, the CTMU can be used to precisely measure time, measure capacitance, measure relative changes in capacitance, or generate output pulses that are independent of the system clock. The CTMU module is ideal for interfacing with capacitive-based touch sensors.

The CTMU is controlled through two registers: CTMUCON and CTMUICON. CTMUCON enables the module, and controls edge source selection, edge

source polarity selection, and edge sequencing. The CTMUICON register selects the current range of current source and trims the current.

### 25.1 Measuring Capacitance

The CTMU module measures capacitance by generating an output pulse with a width equal to the time between edge events on two separate input channels. The pulse edge events to both input channels can be selected from four sources: two internal peripheral modules (OC1 and Timer1) and two external pins (CTED1 and CTED2). This pulse is used with the module’s precision current source to calculate capacitance according to the relationship:

$$I = C \cdot \frac{dV}{dT}$$

For capacitance measurements, the A/D Converter samples an external capacitor (CAPP) on one of its input channels, after the CTMU output’s pulse. A precision resistor (RPR) provides current source calibration on a second A/D channel. After the pulse ends, the converter determines the voltage on the capacitor. The actual calculation of capacitance is performed in software by the application.

Figure 25-1 displays the external connections used for capacitance measurements, and how the CTMU and A/D modules are related in this application. This example also shows the edge events coming from Timer1, but other configurations using external edge sources are possible. A detailed discussion on measuring capacitance and time with the CTMU module is provided in the “PIC24F Family Reference Manual”.

**FIGURE 25-1: TYPICAL CONNECTIONS AND INTERNAL CONFIGURATION FOR CAPACITANCE MEASUREMENT**



# PIC24F16KA102 FAMILY

## 25.2 Measuring Time

Time measurements on the pulse width can be similarly performed using the A/D module's internal capacitor (CAD) and a precision resistor for current calibration. Figure 25-2 displays the external connections used for time measurements, and how the CTMU and A/D modules are related in this application. This example also shows both edge events coming from the external CTED pins, but other configurations using internal edge sources are possible.

## 25.3 Pulse Generation and Delay

The CTMU module can also generate an output pulse with edges that are not synchronous with the device's system clock. More specifically, it can generate a pulse with a programmable delay from an edge event input to the module.

When the module is configured for pulse generation delay by setting the TGEN bit (CTMUCON<12>), the internal current source is connected to the B input of Comparator 2. A capacitor (CDELAY) is connected to the Comparator 2 pin, C2INB, and the comparator voltage reference, CVREF, is connected to C2INA. CVREF is then configured for a specific trip point. The module begins to charge CDELAY when an edge event is detected. When CDELAY charges above the CVREF trip point, a pulse is output on CTPLS. The length of the pulse delay is determined by the value of CDELAY and the CVREF trip point.

Figure 25-3 shows the external connections for pulse generation, as well as the relationship of the different analog modules required. While CTED1 is shown as the input pulse source, other options are available. A detailed discussion on pulse generation with the CTMU module is provided in the "PIC24F Family Reference Manual".

FIGURE 25-2: TYPICAL CONNECTIONS AND INTERNAL CONFIGURATION FOR TIME MEASUREMENT



FIGURE 25-3: TYPICAL CONNECTIONS AND INTERNAL CONFIGURATION FOR PULSE DELAY GENERATION



# PIC24F16KA102 FAMILY

## REGISTER 25-1: CTMUCON: CTMU CONTROL REGISTER

R/W-0	U-0	R/W-0	R/W-0	R/W-0	R/W-0	R/W-0	R/W-0
CTMUEN	—	CTMUSIDL	TGEN	EDGEN	EDGSEQEN	IDISSEN	CTTRIG
bit 15							bit 8

R/W-0	R/W-0	R/W-0	R/W-0	R/W-0	R/W-0	R/W-0	R/W-0
EDG2POL	EDG2SEL1	EDG2SEL0	EDG1POL	EDG1SEL1	EDG1SEL0	EDG2STAT	EDG1STAT
bit 7							bit 0

### Legend:

R = Readable bit                      W = Writable bit                      U = Unimplemented bit, read as '0'  
 -n = Value at POR                      '1' = Bit is set                      '0' = Bit is cleared                      x = Bit is unknown

- bit 15            **CTMUEN:** CTMU Enable bit  
                   1 = Module is enabled  
                   0 = Module is disabled
- bit 14            **Unimplemented:** Read as '0'
- bit 13            **CTMUSIDL:** Stop in Idle Mode bit  
                   1 = Discontinue module operation when device enters Idle mode  
                   0 = Continue module operation in Idle mode
- bit 12            **TGEN:** Time Generation Enable bit  
                   1 = Enables edge delay generation  
                   0 = Disables edge delay generation
- bit 11            **EDGEN:** Edge Enable bit  
                   1 = Edges are not blocked  
                   0 = Edges are blocked
- bit 10            **EDGSEQEN:** Edge Sequence Enable bit  
                   1 = Edge 1 event must occur before Edge 2 event can occur  
                   0 = No edge sequence is needed
- bit 9             **IDISSEN:** Analog Current Source Control bit  
                   1 = Analog current source output is grounded  
                   0 = Analog current source output is not grounded
- bit 8             **CTTRIG:** Trigger Control bit  
                   1 = Trigger output is enabled  
                   0 = Trigger output is disabled
- bit 7             **EDG2POL:** Edge 2 Polarity Select bit  
                   1 = Edge 2 is programmed for a positive edge response  
                   0 = Edge 2 is programmed for a negative edge response
- bit 6-5          **EDG2SEL<1:0>:** Edge 2 Source Select bits  
                   11 = CTED1 pin  
                   10 = CTED2 pin  
                   01 = OC1 module  
                   00 = Timer1 module
- bit 4             **EDG1POL:** Edge 1 Polarity Select bit  
                   1 = Edge 1 is programmed for a positive edge response  
                   0 = Edge 1 is programmed for a negative edge response

# PIC24F16KA102 FAMILY

## REGISTER 25-1: CTMUCON: CTMU CONTROL REGISTER (CONTINUED)

- bit 3-2      **EDG1SEL<1:0>**: Edge 1 Source Select bits  
             11 = CTED1 pin  
             10 = CTED2 pin  
             01 = OC1 module  
             00 = Timer1 module
- bit 1        **EDG2STAT**: Edge 2 Status bit  
             1 = Edge 2 event has occurred  
             0 = Edge 2 event has not occurred
- bit 0        **EDG1STAT**: Edge 1 Status bit  
             1 = Edge 1 event has occurred  
             0 = Edge 1 event has not occurred

## REGISTER 25-2: CTMUICON: CTMU CURRENT CONTROL REGISTER

R/W-0	R/W-0	R/W-0	R/W-0	R/W-0	R/W-0	R/W-0	R/W-0
ITRIM5	ITRIM4	ITRIM3	ITRIM2	ITRIM1	ITRIM0	IRNG1	IRNG0
bit 15						bit 8	

U-0	U-0	U-0	U-0	U-0	U-0	U-0	U-0
—	—	—	—	—	—	—	—
bit 7						bit 0	

### Legend:

R = Readable bit	W = Writable bit	U = Unimplemented bit, read as '0'
-n = Value at POR	'1' = Bit is set	'0' = Bit is cleared
		x = Bit is unknown

- bit 15-10    **ITRIM<5:0>**: Current Source Trim bits  
             011111 = Maximum positive change from nominal current  
             011110  
             .  
             .  
             .  
             000001 = Minimum positive change from nominal current  
             000000 = Nominal current output specified by IRNG<1:0>  
             111111 = Minimum negative change from nominal current  
             .  
             .  
             .  
             100010  
             100000 = Maximum negative change from nominal current
- bit 9-8      **IRNG<1:0>**: Current Source Range Select bits  
             11 = 100 × Base current  
             10 = 10 × Base current  
             01 = Base current level (0.55 μA nominal)  
             00 = Current source is disabled
- bit 7-0      **Unimplemented**: Read as '0'



# PIC24F16KA102 FAMILY

## 26.0 SPECIAL FEATURES

**Note:** This data sheet summarizes the features of this group of PIC24F devices. It is not intended to be a comprehensive reference source. For more information on the Watchdog Timer, High-Level Device integration and Programming Diagnostics, refer to the individual sections of the “PIC24F Family Reference Manual” provided below:

- **Section 9. “Watchdog Timer (WDT)”** (DS39697)
- **Section 36. “High-Level Integration with Programmable High/Low-Voltage Detect (HLVD)”** (DS39725)
- **Section 33. “Programming and Diagnostics”** (DS39716)

PIC24F16KA102 family devices include several features intended to maximize application flexibility and reliability, and minimize cost through elimination of external components. These are:

- Flexible Configuration
- Watchdog Timer (WDT)
- Code Protection
- In-Circuit Serial Programming™ (ICSP™)
- In-Circuit Emulation

### REGISTER 26-1: FBS: BOOT SEGMENT CONFIGURATION REGISTER

U-0	U-0	U-0	U-0	R/W-1	R/W-1	R/W-1	R/W-1
—	—	—	—	BSS2	BSS1	BSS0	BWRP
bit 7							bit 0

#### Legend:

R = Readable bit                      W = Writable bit                      U = Unimplemented bit, read as ‘0’  
 -n = Value at POR                      ‘1’ = Bit is set                      ‘0’ = Bit is cleared                      x = Bit is unknown

- bit 7-4            **Unimplemented:** Read as ‘0’
- bit 3-1            **BSS<2:0>:** Boot Segment Program Flash Code Protection bits
- 111 = No boot program Flash segment
  - 011 = Reserved
  - 110 = Standard security, boot program Flash segment starts at 200h, ends at 000AFEh
  - 010 = High-security boot program Flash segment starts at 200h, ends at 000AFEh
  - 101 = Standard security, boot program Flash segment starts at 200h, ends at 0015FEh<sup>(1)</sup>
  - 001 = High-security, boot program Flash segment starts at 200h, ends at 0015FEh<sup>(1)</sup>
  - 100 = Reserved
  - 000 = Reserved
- bit 0            **BWRP:** Boot Segment Program Flash Write Protection bit
- 1 = Boot segment may be written
  - 0 = Boot segment is write-protected

**Note 1:** This selection should not be used in PIC24F08KA1XX devices.

## 26.1 Configuration Bits

The Configuration bits can be programmed (read as ‘0’), or left unprogrammed (read as ‘1’), to select various device configurations. These bits are mapped, starting at program memory location, F80000h. A complete list is provided in [Table 26-1](#). A detailed explanation of the various bit functions is provided in [Register 26-1](#) through [Register 26-8](#).

The address, F80000h, is beyond the user program memory space. In fact, it belongs to the configuration memory space (800000h-FFFFFFh), which can only be accessed using table reads and table writes.

**TABLE 26-1: CONFIGURATION REGISTERS LOCATIONS**

Configuration Register	Address
FBS	F80000
FGS	F80004
FOSCSEL	F80006
FOSC	F80008
FWDT	F8000A
FPOR	F8000C
FICD	F8000E
FDS	F80010

# PIC24F16KA102 FAMILY

## REGISTER 26-2: FGS: GENERAL SEGMENT CONFIGURATION REGISTER

U-0	U-0	U-0	U-0	U-0	U-0	R/C-1	R/C-1
—	—	—	—	—	—	GSS0	GWRP
bit 7						bit 0	

### Legend:

R = Readable bit                      C = Clearable bit                      U = Unimplemented bit, read as '0'  
 -n = Value at POR                      '1' = Bit is set                      '0' = Bit is cleared                      x = Bit is unknown

- bit 7-2            **Unimplemented:** Read as '0'
- bit 1            **GSS0:** General Segment Code Flash Code Protection bit  
                   1 = No protection  
                   0 = Standard security is enabled
- bit 0            **GWRP:** General Segment Code Flash Write Protection bit  
                   1 = General segment may be written  
                   0 = General segment is write-protected

## REGISTER 26-3: FOSCSEL: OSCILLATOR SELECTION CONFIGURATION REGISTER

R/P-1	U-0	U-0	U-0	U-0	R/P-1	R/P-1	R/P-1
IESO	—	—	—	—	FNOSC2	FNOSC1	FNOSC0
bit 7						bit 0	

### Legend:

R = Readable bit                      P = Programmable bit                      U = Unimplemented bit, read as '0'  
 -n = Value at POR                      '1' = Bit is set                      '0' = Bit is cleared                      x = Bit is unknown

- bit 7            **IESO:** Internal External Switchover bit  
                   1 = Internal External Switchover mode is enabled (Two-Speed Start-up is enabled)  
                   0 = Internal External Switchover mode is disabled (Two-Speed Start-up is disabled)
- bit 6-3            **Unimplemented:** Read as '0'
- bit 2-0            **FNOSC<2:0>:** Oscillator Selection bits  
                   000 = Fast RC Oscillator (FRC)  
                   001 = Fast RC Oscillator with divide-by-N with PLL module (FRCDIV+PLL)  
                   010 = Primary Oscillator (XT, HS, EC)  
                   011 = Primary Oscillator with PLL module (HS+PLL, EC+PLL)  
                   100 = Secondary Oscillator (SOSC)  
                   101 = Low-Power RC Oscillator (LPRC)  
                   110 = 500 kHz Low-Power FRC Oscillator with divide-by-N (LPFRCDIV)  
                   111 = 8 MHz FRC Oscillator with divide-by-N (FRCDIV)

# PIC24F16KA102 FAMILY

## REGISTER 26-4: FOSC: OSCILLATOR CONFIGURATION REGISTER

R/P-1	R/P-1	R/P-1	R/P-1	R/P-1	R/P-1	R/P-1	R/P-1
FCKSM1	FCKSM0	SOSCSEL	POSCFREQ1	POSCFREQ0	OSCIOFNC	POSCMD1	POSCMD0
bit 7							bit 0

### Legend:

R = Readable bit	P = Programmable bit	U = Unimplemented bit, read as '0'
-n = Value at POR	'1' = Bit is set	'0' = Bit is cleared
		x = Bit is unknown

- bit 7-6 **FCKSM<1:0>**: Clock Switching and Monitor Selection Configuration bits  
 1x = Clock switching is disabled, Fail-Safe Clock Monitor is disabled  
 01 = Clock switching is enabled, Fail-Safe Clock Monitor is disabled  
 00 = Clock switching is enabled, Fail-Safe Clock Monitor is enabled
- bit 5 **SOSCSEL**: Secondary Oscillator Select bit  
 1 = Secondary oscillator is configured for high-power operation  
 0 = Secondary oscillator is configured for low-power operation
- bit 4-3 **POSCFREQ<1:0>**: Primary Oscillator Frequency Range Configuration bits  
 11 = Primary oscillator/external clock input frequency is greater than 8 MHz  
 10 = Primary oscillator/external clock input frequency is between 100 kHz and 8 MHz  
 01 = Primary oscillator/external clock input frequency is less than 100 kHz  
 00 = Reserved; do not use
- bit 2 **OSCIOFNC**: CLKO Enable Configuration bit  
 1 = CLKO output signal active on the OSCO pin; primary oscillator must be disabled or configured for the External Clock mode (EC) for the CLKO to be active (POSCMD<1:0> = 11 or 00)  
 0 = CLKO output is disabled
- bit 1-0 **POSCMD<1:0>**: Primary Oscillator Configuration bits  
 11 = Primary Oscillator mode is disabled  
 10 = HS Oscillator mode is selected  
 01 = XT Oscillator mode is selected  
 00 = External Clock mode is selected

# PIC24F16KA102 FAMILY

## REGISTER 26-5: FWDT: WATCHDOG TIMER CONFIGURATION REGISTER

R/P-1	R/P-1	U-0	R/P-1	R/P-1	R/P-1	R/P-1	R/P-1
FWDTEN	WINDIS	—	FWPSA	WDTPS3	WDTPS2	WDTPS1	WDTPS0
bit 7							bit 0

### Legend:

R = Readable bit                      P = Programmable bit                      U = Unimplemented bit, read as '0'  
 -n = Value at POR                      '1' = Bit is set                      '0' = Bit is cleared                      x = Bit is unknown

- bit 7            **FWDTEN:** Watchdog Timer Enable bit  
                   1 = WDT is enabled  
                   0 = WDT is disabled (control is placed on the SWDTEN bit)
- bit 6            **WINDIS:** Windowed Watchdog Timer Disable bit  
                   1 = Standard WDT is selected; windowed WDT disabled  
                   0 = Windowed WDT is enabled
- bit 5            **Unimplemented:** Read as '0'
- bit 4            **FWPSA:** WDT Prescaler bit  
                   1 = WDT prescaler ratio of 1:128  
                   0 = WDT prescaler ratio of 1:32
- bit 3-0        **WDTPS<3:0>:** Watchdog Timer Postscale Select bits  
                   1111 = 1:32,768  
                   1110 = 1:16,384  
                   1101 = 1:8,192  
                   1100 = 1:4,096  
                   1011 = 1:2,048  
                   1010 = 1:1,024  
                   1001 = 1:512  
                   1000 = 1:256  
                   0111 = 1:128  
                   0110 = 1:64  
                   0101 = 1:32  
                   0100 = 1:16  
                   0011 = 1:8  
                   0010 = 1:4  
                   0001 = 1:2  
                   0000 = 1:1

# PIC24F16KA102 FAMILY

**REGISTER 26-6: FPOR: RESET CONFIGURATION REGISTER**

R/P-1	R/P-1	R/P-1	R/P-1	R/P-1	U-0	R/P-1	R/P-1
MCLRE <sup>(2)</sup>	BORV1 <sup>(3)</sup>	BORV0 <sup>(3)</sup>	I2C1SEL <sup>(1)</sup>	PWRTEN	—	BOREN1	BOREN0
bit 7							bit 0

**Legend:**

R = Readable bit	P = Programmable bit	U = Unimplemented bit, read as '0'
-n = Value at POR	'1' = Bit is set	'0' = Bit is cleared
		x = Bit is unknown

- bit 7      **MCLRE:** MCLR Pin Enable bit<sup>(2)</sup>  
             1 = MCLR pin is enabled; RA5 input pin is disabled  
             0 = RA5 input pin is enabled; MCLR is disabled
- bit 6-5    **BORV<1:0>:** Brown-out Reset Enable bits<sup>(3)</sup>  
             11 = Brown-out Reset is set to the lowest voltage  
             10 = Brown-out Reset  
             01 = Brown-out Reset is set to the highest voltage  
             00 = Low-Power Brown-out Reset occurs around 2.0V
- bit 4      **I2C1SEL:** Alternate I2C1 Pin Mapping bit<sup>(1)</sup>  
             0 = Alternate location for SCL1/SDA1 pins  
             1 = Default location for SCL1/SDA1 pins
- bit 3      **PWRTEN:** Power-up Timer Enable bit  
             0 = PWRT is disabled  
             1 = PWRT is enabled
- bit 2      **Unimplemented:** Read as '0'
- bit 1-0    **BOREN<1:0>:** Brown-out Reset Enable bits  
             11 = Brown-out Reset is enabled in hardware; SBOREN bit is disabled  
             10 = Brown-out Reset is enabled only while device is active and disabled in Sleep; SBOREN bit is disabled  
             01 = Brown-out Reset is controlled with the SBOREN bit setting  
             00 = Brown-out Reset is disabled in hardware; SBOREN bit is disabled

- Note 1:** Applies only to 28-pin devices.
- 2:** The MCLRE fuse can only be changed when using the VPP-Based ICSP™ mode entry. This prevents a user from accidentally locking out the device from the low-voltage test entry.
- 3:** Refer to [Section 29.0, Electrical Characteristics](#) for the BOR voltages.

# PIC24F16KA102 FAMILY

## REGISTER 26-7: FICD: IN-CIRCUIT DEBUGGER CONFIGURATION REGISTER

R/P-1	U-0	U-0	U-0	U-0	U-0	R/P-1	R/P-1
DEBUG	—	—	—	—	—	FICD1	FICD0
bit 7							bit 0

### Legend:

R = Readable bit

P = Programmable bit

U = Unimplemented bit, read as '0'

-n = Value at POR

'1' = Bit is set

'0' = Bit is cleared

x = Bit is unknown

bit 7

**DEBUG:** Background Debugger Enable bit

1 = Background debugger is disabled

0 = Background debugger functions are enabled

bit 6-2

**Unimplemented:** Read as '0'

bit 1-0

**FICD<1:0>:** ICD Pin Select bits

11 = PGC1/PGD1 are used for programming and debugging the device

10 = PGC2/PGD2 are used for programming and debugging the device

01 = PGC3/PGD3 are used for programming and debugging the device

00 = Reserved; do not use

# PIC24F16KA102 FAMILY

## REGISTER 26-8: FDS: DEEP SLEEP CONFIGURATION REGISTER

R/P-1	R/P-1	R/P-1	R/P-1	R/P-1	R/P-1	R/P-1	R/P-1
DSWDTEN	DSBOREN	RTCOSC	DSWDTOSC	DSWDTPS3	DSWDTPS2	DSWDTPS1	DSWDTPS0
bit 7							bit 0

### Legend:

R = Readable bit	P = Programmable bit	U = Unimplemented bit, read as '0'
-n = Value at POR	'1' = Bit is set	'0' = Bit is cleared
		x = Bit is unknown

- bit 7      **DSWDTEN:** Deep Sleep Watchdog Timer Enable bit  
 1 = DSWDT is enabled  
 0 = DSWDT is disabled
- bit 6      **DSBOREN:** Deep Sleep/Low-Power BOR Enable bit (does not affect operation in non Deep Sleep modes)  
 1 = Deep Sleep BOR is enabled in Deep Sleep  
 0 = Deep Sleep BOR is disabled in Deep Sleep
- bit 5      **RTCOSC:** RTCC Reference Clock Select bit  
 1 = RTCC uses SOSC as a reference clock  
 0 = RTCC uses LPRC as a reference clock
- bit 4      **DSWDTOSC:** DSWDT Reference Clock Select bit  
 1 = DSWDT uses LPRC as a reference clock  
 0 = DSWDT uses SOSC as a reference clock
- bit 3-0    **DSWDTPS<3:0>:** Deep Sleep Watchdog Timer Postscale Select bits  
 The DSWDT prescaler is 32; this creates an approximate base time unit of 1 ms.  
 1111 = 1:2,147,483,648 (25.7 days) nominal  
 1110 = 1:536,870,912 (6.4 days) nominal  
 1101 = 1:134,217,728 (38.5 hours) nominal  
 1100 = 1:33,554,432 (9.6 hours) nominal  
 1011 = 1:8,388,608 (2.4 hours) nominal  
 1010 = 1:2,097,152 (36 minutes) nominal  
 1001 = 1:524,288 (9 minutes) nominal  
 1000 = 1:131,072 (135 seconds) nominal  
 0111 = 1:32,768 (34 seconds) nominal  
 0110 = 1:8,192 (8.5 seconds) nominal  
 0101 = 1:2,048 (2.1 seconds) nominal  
 0100 = 1:512 (528 ms) nominal  
 0011 = 1:128 (132 ms) nominal  
 0010 = 1:32 (33 ms) nominal  
 0001 = 1:8 (8.3 ms) nominal  
 0000 = 1:2 (2.1 ms) nominal

# PIC24F16KA102 FAMILY

## REGISTER 26-9: DEVID: DEVICE ID REGISTER

U-0	U-0	U-0	U-0	U-0	U-0	U-0	U-0
—	—	—	—	—	—	—	—
bit 23							bit 16

R	R	R	R	R	R	R	R
FAMID7	FAMID6	FAMID5	FAMID4	FAMID3	FAMID2	FAMID1	FAMID0
bit 15							bit 8

R	R	R	R	R	R	R	R
DEV7	DEV6	DEV5	DEV4	DEV3	DEV2	DEV1	DEV0
bit 7							bit 0

### Legend:

R = Readable bit

W = Writable bit

U = Unimplemented bit, read as '0'

-n = Value at POR

'1' = Bit is set

'0' = Bit is cleared

x = Bit is unknown

bit 23-16 **Unimplemented:** Read as '0'

bit 15-8 **FAMID<7:0>:** Device Family Identifier bits

00001011 = PIC24F16KA102 family

bit 7-0 **DEV<7:0>:** Individual Device Identifier bits

00000011 = PIC24F16KA102

00001010 = PIC24F08KA102

00000001 = PIC24F16KA101

00001000 = PIC24F08KA101

## REGISTER 26-10: DEVREV: DEVICE REVISION REGISTER

U-0	U-0	U-0	U-0	U-0	U-0	U-0	U-0
—	—	—	—	—	—	—	—
bit 23							bit 16

U-0	U-0	U-0	U-0	U-0	U-0	U-0	U-0
—	—	—	—	—	—	—	—
bit 15							bit 8

U-0	U-0	U-0	U-0	R	R	R	R
—	—	—	—	REV3	REV2	REV1	REV0
bit 7							bit 0

### Legend:

R = Readable bit

W = Writable bit

U = Unimplemented bit, read as '0'

-n = Value at POR

'1' = Bit is set

'0' = Bit is cleared

x = Bit is unknown

bit 23-4 **Unimplemented:** Read as '0'

bit 3-0 **REV<3:0>:** Minor Revision Identifier bits



# PIC24F16KA102 FAMILY

## 26.2 Watchdog Timer (WDT)

For the PIC24F16KA102 family of devices, the WDT is driven by the LPRC oscillator. When the WDT is enabled, the clock source is also enabled.

The nominal WDT clock source from LPRC is 31 kHz. This feeds a prescaler that can be configured for either 5-bit (divide-by-32) or 7-bit (divide-by-128) operation. The prescaler is set by the FWPSA Configuration bit. With a 31 kHz input, the prescaler yields a nominal WDT time-out period ( $T_{WDT}$ ) of 1 ms in 5-bit mode or 4 ms in 7-bit mode.

A variable postscaler divides down the WDT prescaler output and allows for a wide range of time-out periods. The postscaler is controlled by the Configuration bits,  $WDTPS<3:0>$  ( $FWDT<3:0>$ ), which allow the selection of a total of 16 settings, from 1:1 to 1:32,768. Using the prescaler and postscaler time-out periods, ranging from 1 ms to 131 seconds, can be achieved.

The WDT, prescaler and postscaler are reset:

- On any device Reset
- On the completion of a clock switch, whether invoked by software (i.e., setting the OSWEN bit after changing the NOSC bits) or by hardware (i.e., Fail-Safe Clock Monitor)
- When a `PWRSVAV` instruction is executed (i.e., Sleep or Idle mode is entered)
- When the device exits Sleep or Idle mode to resume normal operation
- By a `CLRWDT` instruction During normal execution

If the WDT is enabled, it will continue to run during Sleep or Idle modes. When the WDT time-out occurs, the device will wake the device and code execution will continue from where the `PWRSVAV` instruction was

executed. The corresponding SLEEP or IDLE bits ( $RCON<3:2>$ ) will need to be cleared in software after the device wakes up.

The WDT Flag bit,  $WDTO$  ( $RCON<4>$ ), is not automatically cleared following a WDT time-out. To detect subsequent WDT events, the flag must be cleared in software.

**Note:** The `CLRWDT` and `PWRSVAV` instructions clear the prescaler and postscaler counts when executed.

### 26.2.1 WINDOWED OPERATION

The Watchdog Timer has an optional Fixed Window mode of operation. In this Windowed mode, `CLRWDT` instructions can only reset the WDT during the last 1/4 of the programmed WDT period. A `CLRWDT` instruction executed before that window causes a WDT Reset, similar to a WDT time-out.

Windowed WDT mode is enabled by programming the Configuration bit,  $WINDIS$  ( $FWDT<6>$ ), to '0'.

### 26.2.2 CONTROL REGISTER

The WDT is enabled or disabled by the  $FWDTEN$  Configuration bit. When the  $FWDTEN$  Configuration bit is set, the WDT is always enabled.

The WDT can be optionally controlled in software when the  $FWDTEN$  Configuration bit has been programmed to '0'. The WDT is enabled in software by setting the  $SWDTEN$  control bit ( $RCON<5>$ ). The  $SWDTEN$  control bit is cleared on any device Reset. The software WDT option allows the user to enable the WDT for critical code segments and disable the WDT during non-critical segments for maximum power savings.

**FIGURE 26-1: WDT BLOCK DIAGRAM**



# PIC24F16KA102 FAMILY

---

## 26.3 Deep Sleep Watchdog Timer (DSWDT)

In PIC24F16KA102 family devices, in addition to the WDT module, a DSWDT module is present which runs while the device is in Deep Sleep, if enabled. It is driven by either the SOSC or LPRC oscillator. The clock source is selected by the Configuration bit, DSWDTOSC (FDS<4>).

The DSWDT can be configured to generate a time-out at 2.1 ms to 25.7 days by selecting the respective postscaler. The postscaler can be selected by the Configuration bits, DSWDTPS<3:0> (FDS<3:0>). When the DSWDT is enabled, the clock source is also enabled.

DSWDT is one of the sources that can wake-up the device from Deep Sleep mode.

## 26.4 Program Verification and Code Protection

For all devices in the PIC24F16KA102 family, code protection for the boot segment is controlled by the Configuration bit, BSS0, and the general segment by the Configuration bit, GSS0. These bits inhibit external reads and writes to the program memory space; this has no direct effect in normal execution mode.

Write protection is controlled by bit, BWRP, for the boot segment and bit, GWRP, for the general segment in the Configuration Word. When these bits are programmed to '0', internal write and erase operations to program memory are blocked.

## 26.5 In-Circuit Serial Programming

PIC24F16KA102 family microcontrollers can be serially programmed while in the end application circuit. This is simply done with two lines for clock (PGCx) and data (PGDx), and three other lines for power, ground and the programming voltage. This allows customers to manufacture boards with unprogrammed devices and then program the microcontroller just before shipping the product. This also allows the most recent firmware or a custom firmware to be programmed.

## 26.6 In-Circuit Debugger

When MPLAB® ICD 2 is selected as a debugger, the in-circuit debugging functionality is enabled. This function allows simple debugging functions when used with MPLAB IDE. Debugging functionality is controlled through the EMUCx (Emulation/Debug Clock) and EMUDx (Emulation/Debug Data) pins.

To use the in-circuit debugger function of the device, the design must implement ICSP connections to MCLR, VDD, VSS, PGCx, PGDx and the EMUDx/EMUCx pin pair. In addition, when the feature is enabled, some of the resources are not available for general use. These resources include the first 80 bytes of data RAM and two I/O pins.

# PIC24F16KA102 FAMILY

---

## 27.0 DEVELOPMENT SUPPORT

The PIC® microcontrollers and dsPIC® digital signal controllers are supported with a full range of software and hardware development tools:

- Integrated Development Environment
  - MPLAB® IDE Software
- Compilers/Assemblers/Linkers
  - MPLAB C Compiler for Various Device Families
  - HI-TECH C® for Various Device Families
  - MPASM™ Assembler
  - MPLINK™ Object Linker/  
MPLIB™ Object Librarian
  - MPLAB Assembler/Linker/Librarian for Various Device Families
- Simulators
  - MPLAB SIM Software Simulator
- Emulators
  - MPLAB REAL ICE™ In-Circuit Emulator
- In-Circuit Debuggers
  - MPLAB ICD 3
  - PICKit™ 3 Debug Express
- Device Programmers
  - PICKit™ 2 Programmer
  - MPLAB PM3 Device Programmer
- Low-Cost Demonstration/Development Boards, Evaluation Kits, and Starter Kits

## 27.1 MPLAB Integrated Development Environment Software

The MPLAB IDE software brings an ease of software development previously unseen in the 8/16/32-bit microcontroller market. The MPLAB IDE is a Windows® operating system-based application that contains:

- A single graphical interface to all debugging tools
  - Simulator
  - Programmer (sold separately)
  - In-Circuit Emulator (sold separately)
  - In-Circuit Debugger (sold separately)
- A full-featured editor with color-coded context
- A multiple project manager
- Customizable data windows with direct edit of contents
- High-level source code debugging
- Mouse over variable inspection
- Drag and drop variables from source to watch windows
- Extensive on-line help
- Integration of select third party tools, such as IAR C Compilers

The MPLAB IDE allows you to:

- Edit your source files (either C or assembly)
- One-touch compile or assemble, and download to emulator and simulator tools (automatically updates all project information)
- Debug using:
  - Source files (C or assembly)
  - Mixed C and assembly
  - Machine code

MPLAB IDE supports multiple debugging tools in a single development paradigm, from the cost-effective simulators, through low-cost in-circuit debuggers, to full-featured emulators. This eliminates the learning curve when upgrading to tools with increased flexibility and power.

# PIC24F16KA102 FAMILY

---

## 27.2 MPLAB C Compilers for Various Device Families

The MPLAB C Compiler code development systems are complete ANSI C compilers for Microchip's PIC18, PIC24 and PIC32 families of microcontrollers and the dsPIC30 and dsPIC33 families of digital signal controllers. These compilers provide powerful integration capabilities, superior code optimization and ease of use.

For easy source level debugging, the compilers provide symbol information that is optimized to the MPLAB IDE debugger.

## 27.3 HI-TECH C for Various Device Families

The HI-TECH C Compiler code development systems are complete ANSI C compilers for Microchip's PIC family of microcontrollers and the dsPIC family of digital signal controllers. These compilers provide powerful integration capabilities, omniscient code generation and ease of use.

For easy source level debugging, the compilers provide symbol information that is optimized to the MPLAB IDE debugger.

The compilers include a macro assembler, linker, pre-processor, and one-step driver, and can run on multiple platforms.

## 27.4 MPASM Assembler

The MPASM Assembler is a full-featured, universal macro assembler for PIC10/12/16/18 MCUs.

The MPASM Assembler generates relocatable object files for the MPLINK Object Linker, Intel® standard HEX files, MAP files to detail memory usage and symbol reference, absolute LST files that contain source lines and generated machine code and COFF files for debugging.

The MPASM Assembler features include:

- Integration into MPLAB IDE projects
- User-defined macros to streamline assembly code
- Conditional assembly for multi-purpose source files
- Directives that allow complete control over the assembly process

## 27.5 MPLINK Object Linker/ MPLIB Object Librarian

The MPLINK Object Linker combines relocatable objects created by the MPASM Assembler and the MPLAB C18 C Compiler. It can link relocatable objects from precompiled libraries, using directives from a linker script.

The MPLIB Object Librarian manages the creation and modification of library files of precompiled code. When a routine from a library is called from a source file, only the modules that contain that routine will be linked in with the application. This allows large libraries to be used efficiently in many different applications.

The object linker/library features include:

- Efficient linking of single libraries instead of many smaller files
- Enhanced code maintainability by grouping related modules together
- Flexible creation of libraries with easy module listing, replacement, deletion and extraction

## 27.6 MPLAB Assembler, Linker and Librarian for Various Device Families

MPLAB Assembler produces relocatable machine code from symbolic assembly language for PIC24, PIC32 and dsPIC devices. MPLAB C Compiler uses the assembler to produce its object file. The assembler generates relocatable object files that can then be archived or linked with other relocatable object files and archives to create an executable file. Notable features of the assembler include:

- Support for the entire device instruction set
- Support for fixed-point and floating-point data
- Command line interface
- Rich directive set
- Flexible macro language
- MPLAB IDE compatibility

## 27.7 MPLAB SIM Software Simulator

The MPLAB SIM Software Simulator allows code development in a PC-hosted environment by simulating the PIC MCUs and dsPIC® DSCs on an instruction level. On any given instruction, the data areas can be examined or modified and stimuli can be applied from a comprehensive stimulus controller. Registers can be logged to files for further run-time analysis. The trace buffer and logic analyzer display extend the power of the simulator to record and track program execution, actions on I/O, most peripherals and internal registers.

The MPLAB SIM Software Simulator fully supports symbolic debugging using the MPLAB C Compilers, and the MPASM and MPLAB Assemblers. The software simulator offers the flexibility to develop and debug code outside of the hardware laboratory environment, making it an excellent, economical software development tool.

## 27.8 MPLAB REAL ICE In-Circuit Emulator System

MPLAB REAL ICE In-Circuit Emulator System is Microchip's next generation high-speed emulator for Microchip Flash DSC and MCU devices. It debugs and programs PIC® Flash MCUs and dsPIC® Flash DSCs with the easy-to-use, powerful graphical user interface of the MPLAB Integrated Development Environment (IDE), included with each kit.

The emulator is connected to the design engineer's PC using a high-speed USB 2.0 interface and is connected to the target with either a connector compatible with in-circuit debugger systems (RJ11) or with the new high-speed, noise tolerant, Low-Voltage Differential Signal (LVDS) interconnection (CAT5).

The emulator is field upgradable through future firmware downloads in MPLAB IDE. In upcoming releases of MPLAB IDE, new devices will be supported, and new features will be added. MPLAB REAL ICE offers significant advantages over competitive emulators including low-cost, full-speed emulation, run-time variable watches, trace analysis, complex breakpoints, a ruggedized probe interface and long (up to three meters) interconnection cables.

## 27.9 MPLAB ICD 3 In-Circuit Debugger System

MPLAB ICD 3 In-Circuit Debugger System is Microchip's most cost effective high-speed hardware debugger/programmer for Microchip Flash Digital Signal Controller (DSC) and microcontroller (MCU) devices. It debugs and programs PIC® Flash microcontrollers and dsPIC® DSCs with the powerful, yet easy-to-use graphical user interface of MPLAB Integrated Development Environment (IDE).

The MPLAB ICD 3 In-Circuit Debugger probe is connected to the design engineer's PC using a high-speed USB 2.0 interface and is connected to the target with a connector compatible with the MPLAB ICD 2 or MPLAB REAL ICE systems (RJ-11). MPLAB ICD 3 supports all MPLAB ICD 2 headers.

## 27.10 PICkit 3 In-Circuit Debugger/Programmer and PICkit 3 Debug Express

The MPLAB PICkit 3 allows debugging and programming of PIC® and dsPIC® Flash microcontrollers at a most affordable price point using the powerful graphical user interface of the MPLAB Integrated Development Environment (IDE). The MPLAB PICkit 3 is connected to the design engineer's PC using a full speed USB interface and can be connected to the target via an Microchip debug (RJ-11) connector (compatible with MPLAB ICD 3 and MPLAB REAL ICE). The connector uses two device I/O pins and the reset line to implement in-circuit debugging and In-Circuit Serial Programming™.

The PICkit 3 Debug Express include the PICkit 3, demo board and microcontroller, hookup cables and CDROM with user's guide, lessons, tutorial, compiler and MPLAB IDE software.

# PIC24F16KA102 FAMILY

---

## 27.11 PICkit 2 Development Programmer/Debugger and PICkit 2 Debug Express

The PICkit™ 2 Development Programmer/Debugger is a low-cost development tool with an easy to use interface for programming and debugging Microchip's Flash families of microcontrollers. The full featured Windows® programming interface supports baseline (PIC10F, PIC12F5xx, PIC16F5xx), midrange (PIC12F6xx, PIC16F), PIC18F, PIC24, dsPIC30, dsPIC33, and PIC32 families of 8-bit, 16-bit, and 32-bit microcontrollers, and many Microchip Serial EEPROM products. With Microchip's powerful MPLAB Integrated Development Environment (IDE) the PICkit™ 2 enables in-circuit debugging on most PIC® microcontrollers. In-Circuit-Debugging runs, halts and single steps the program while the PIC microcontroller is embedded in the application. When halted at a breakpoint, the file registers can be examined and modified.

The PICkit 2 Debug Express include the PICkit 2, demo board and microcontroller, hookup cables and CDROM with user's guide, lessons, tutorial, compiler and MPLAB IDE software.

## 27.12 MPLAB PM3 Device Programmer

The MPLAB PM3 Device Programmer is a universal, CE compliant device programmer with programmable voltage verification at VDDMIN and VDDMAX for maximum reliability. It features a large LCD display (128 x 64) for menus and error messages and a modular, detachable socket assembly to support various package types. The ICSP™ cable assembly is included as a standard item. In Stand-Alone mode, the MPLAB PM3 Device Programmer can read, verify and program PIC devices without a PC connection. It can also set code protection in this mode. The MPLAB PM3 connects to the host PC via an RS-232 or USB cable. The MPLAB PM3 has high-speed communications and optimized algorithms for quick programming of large memory devices and incorporates an MMC card for file storage and data applications.

## 27.13 Demonstration/Development Boards, Evaluation Kits, and Starter Kits

A wide variety of demonstration, development and evaluation boards for various PIC MCUs and dsPIC DSCs allows quick application development on fully functional systems. Most boards include prototyping areas for adding custom circuitry and provide application firmware and source code for examination and modification.

The boards support a variety of features, including LEDs, temperature sensors, switches, speakers, RS-232 interfaces, LCD displays, potentiometers and additional EEPROM memory.

The demonstration and development boards can be used in teaching environments, for prototyping custom circuits and for learning about various microcontroller applications.

In addition to the PICDEM™ and dsPICDEM™ demonstration/development board series of circuits, Microchip has a line of evaluation kits and demonstration software for analog filter design, KEELOQ® security ICs, CAN, IrDA®, PowerSmart battery management, SEEVAL® evaluation system, Sigma-Delta ADC, flow rate sensing, plus many more.

Also available are starter kits that contain everything needed to experience the specified device. This usually includes a single application and debug capability, all on one board.

Check the Microchip web page ([www.microchip.com](http://www.microchip.com)) for the complete list of demonstration, development and evaluation kits.

## 28.0 INSTRUCTION SET SUMMARY

**Note:** This chapter is a brief summary of the PIC24F instruction set architecture and is not intended to be a comprehensive reference source.

The PIC24F instruction set adds many enhancements to the previous PIC<sup>®</sup> MCU instruction sets, while maintaining an easy migration from previous PIC MCU instruction sets. Most instructions are a single program memory word. Only three instructions require two program memory locations.

Each single-word instruction is a 24-bit word divided into an 8-bit opcode, which specifies the instruction type and one or more operands, which further specify the operation of the instruction. The instruction set is highly orthogonal and is grouped into four basic categories:

- Word or byte-oriented operations
- Bit-oriented operations
- Literal operations
- Control operations

Table 28-1 lists the general symbols used in describing the instructions. The PIC24F instruction set summary in Table 28-2 lists all the instructions, along with the status flags affected by each instruction.

Most word or byte-oriented W register instructions (including barrel shift instructions) have three operands:

- The first source operand, which is typically a register 'Wb' without any address modifier
- The second source operand, which is typically a register 'Ws' with or without an address modifier
- The destination of the result, which is typically a register 'Wd' with or without an address modifier

However, word or byte-oriented file register instructions have two operands:

- The file register, specified by the value, 'f'
- The destination, which could either be the file register 'f' or the W0 register, which is denoted as 'WREG'

Most bit-oriented instructions (including simple rotate/shift instructions) have two operands:

- The W register (with or without an address modifier) or file register (specified by the value of 'Ws' or 'f')
- The bit in the W register or file register (specified by a literal value or indirectly by the contents of register 'Wb')

The literal instructions that involve data movement may use some of the following operands:

- A literal value to be loaded into a W register or file register (specified by the value of 'k')
- The W register or file register, where the literal value is to be loaded (specified by 'Wb' or 'f')

However, literal instructions that involve arithmetic or logical operations use some of the following operands:

- The first source operand, which is a register 'Wb' without any address modifier
- The second source operand, which is a literal value
- The destination of the result (only if not the same as the first source operand), which is typically a register 'Wd' with or without an address modifier

The control instructions may use some of the following operands:

- A program memory address
- The mode of the table read and table write instructions

All instructions are a single word, except for certain double-word instructions, which were made double-word instructions so that all of the required information is available in these 48 bits. In the second word, the 8 MSBs are '0's. If this second word is executed as an instruction (by itself), it will execute as a NOP.

Most single-word instructions are executed in a single instruction cycle, unless a conditional test is true or the Program Counter (PC) is changed as a result of the instruction. In these cases, the execution takes two instruction cycles, with the additional instruction cycle(s) executed as a NOP. Notable exceptions are the BRA (unconditional/computed branch), indirect CALL/GOTO, all table reads and writes, and RETURN/RETFIE instructions, which are single-word instructions but take two or three cycles.

Certain instructions that involve skipping over the subsequent instruction require either two or three cycles if the skip is performed, depending on whether the instruction being skipped is a single-word or two-word instruction. Moreover, double-word moves require two cycles. The double-word instructions execute in two instruction cycles.

# PIC24F16KA102 FAMILY

**TABLE 28-1: SYMBOLS USED IN OPCODE DESCRIPTIONS**

Field	Description
#text	Means literal defined by "text"
(text)	Means "content of text"
[text]	Means "the location addressed by text"
{ }	Optional field or operation
<n:m>	Register bit field
.b	Byte mode selection
.d	Double-Word mode selection
.S	Shadow register select
.w	Word mode selection (default)
bit4	4-bit bit selection field (used in word addressed instructions) $\in \{0...15\}$
C, DC, N, OV, Z	MCU Status bits: Carry, Digit Carry, Negative, Overflow, Sticky Zero
Expr	Absolute address, label or expression (resolved by the linker)
f	File register address $\in \{0000h...1FFFh\}$
lit1	1-bit unsigned literal $\in \{0,1\}$
lit4	4-bit unsigned literal $\in \{0...15\}$
lit5	5-bit unsigned literal $\in \{0...31\}$
lit8	8-bit unsigned literal $\in \{0...255\}$
lit10	10-bit unsigned literal $\in \{0...255\}$ for Byte mode, $\{0:1023\}$ for Word mode
lit14	14-bit unsigned literal $\in \{0...16384\}$
lit16	16-bit unsigned literal $\in \{0...65535\}$
lit23	23-bit unsigned literal $\in \{0...8388608\}$ ; LSB must be '0'
None	Field does not require an entry, may be blank
PC	Program Counter
Slit10	10-bit signed literal $\in \{-512...511\}$
Slit16	16-bit signed literal $\in \{-32768...32767\}$
Slit6	6-bit signed literal $\in \{-16...16\}$
Wb	Base W register $\in \{W0..W15\}$
Wd	Destination W register $\in \{Wd, [Wd], [Wd++] , [Wd--], [++Wd], [--Wd] \}$
Wdo	Destination W register $\in \{Wnd, [Wnd], [Wnd++] , [Wnd--], [++Wnd], [--Wnd], [Wnd+Wb] \}$
Wm,Wn	Dividend, Divisor working register pair (direct addressing)
Wn	One of 16 working registers $\in \{W0..W15\}$
Wnd	One of 16 destination working registers $\in \{W0..W15\}$
Wns	One of 16 source working registers $\in \{W0..W15\}$
WREG	W0 (working register used in file register instructions)
Ws	Source W register $\in \{Ws, [Ws], [Ws++] , [Ws--], [++Ws], [--Ws] \}$
Wso	Source W register $\in \{Wns, [Wns], [Wns++] , [Wns--], [++Wns], [--Wns], [Wns+Wb] \}$



# PIC24F16KA102 FAMILY

**TABLE 28-2: INSTRUCTION SET OVERVIEW**

Assembly Mnemonic	Assembly Syntax	Description	# of Words	# of Cycles	Status Flags Affected
ADD	ADD f	$f = f + WREG$	1	1	C, DC, N, OV, Z
	ADD f, WREG	$WREG = f + WREG$	1	1	C, DC, N, OV, Z
	ADD #lit10, Wn	$Wd = lit10 + Wd$	1	1	C, DC, N, OV, Z
	ADD Wb, Ws, Wd	$Wd = Wb + Ws$	1	1	C, DC, N, OV, Z
	ADD Wb, #lit5, Wd	$Wd = Wb + lit5$	1	1	C, DC, N, OV, Z
ADDC	ADDC f	$f = f + WREG + (C)$	1	1	C, DC, N, OV, Z
	ADDC f, WREG	$WREG = f + WREG + (C)$	1	1	C, DC, N, OV, Z
	ADDC #lit10, Wn	$Wd = lit10 + Wd + (C)$	1	1	C, DC, N, OV, Z
	ADDC Wb, Ws, Wd	$Wd = Wb + Ws + (C)$	1	1	C, DC, N, OV, Z
	ADDC Wb, #lit5, Wd	$Wd = Wb + lit5 + (C)$	1	1	C, DC, N, OV, Z
AND	AND f	$f = f .AND. WREG$	1	1	N, Z
	AND f, WREG	$WREG = f .AND. WREG$	1	1	N, Z
	AND #lit10, Wn	$Wd = lit10 .AND. Wd$	1	1	N, Z
	AND Wb, Ws, Wd	$Wd = Wb .AND. Ws$	1	1	N, Z
	AND Wb, #lit5, Wd	$Wd = Wb .AND. lit5$	1	1	N, Z
ASR	ASR f	f = Arithmetic Right Shift f	1	1	C, N, OV, Z
	ASR f, WREG	WREG = Arithmetic Right Shift f	1	1	C, N, OV, Z
	ASR Ws, Wd	Wd = Arithmetic Right Shift Ws	1	1	C, N, OV, Z
	ASR Wb, Wns, Wnd	Wnd = Arithmetic Right Shift Wb by Wns	1	1	N, Z
	ASR Wb, #lit5, Wnd	Wnd = Arithmetic Right Shift Wb by lit5	1	1	N, Z
BCLR	BCLR f, #bit4	Bit Clear f	1	1	None
	BCLR Ws, #bit4	Bit Clear Ws	1	1	None
BRA	BRA C, Expr	Branch if Carry	1	1 (2)	None
	BRA GE, Expr	Branch if Greater than or Equal	1	1 (2)	None
	BRA GEU, Expr	Branch if Unsigned Greater than or Equal	1	1 (2)	None
	BRA GT, Expr	Branch if Greater than	1	1 (2)	None
	BRA GTU, Expr	Branch if Unsigned Greater than	1	1 (2)	None
	BRA LE, Expr	Branch if Less than or Equal	1	1 (2)	None
	BRA LEU, Expr	Branch if Unsigned Less than or Equal	1	1 (2)	None
	BRA LT, Expr	Branch if Less than	1	1 (2)	None
	BRA LTU, Expr	Branch if Unsigned Less than	1	1 (2)	None
	BRA N, Expr	Branch if Negative	1	1 (2)	None
	BRA NC, Expr	Branch if Not Carry	1	1 (2)	None
	BRA NN, Expr	Branch if Not Negative	1	1 (2)	None
	BRA NOV, Expr	Branch if Not Overflow	1	1 (2)	None
	BRA NZ, Expr	Branch if Not Zero	1	1 (2)	None
	BRA OV, Expr	Branch if Overflow	1	1 (2)	None
	BRA Expr	Branch Unconditionally	1	2	None
	BRA Z, Expr	Branch if Zero	1	1 (2)	None
	BRA Wn	Computed Branch	1	2	None
BSET	BSET f, #bit4	Bit Set f	1	1	None
	BSET Ws, #bit4	Bit Set Ws	1	1	None
BSW	BSW.C Ws, Wb	Write C bit to Ws<Wb>	1	1	None
	BSW.Z Ws, Wb	Write Z bit to Ws<Wb>	1	1	None
BTG	BTG f, #bit4	Bit Toggle f	1	1	None
	BTG Ws, #bit4	Bit Toggle Ws	1	1	None
BTSC	BTSC f, #bit4	Bit Test f, Skip if Clear	1	1 (2 or 3)	None
	BTSC Ws, #bit4	Bit Test Ws, Skip if Clear	1	1 (2 or 3)	None

# PIC24F16KA102 FAMILY

**TABLE 28-2: INSTRUCTION SET OVERVIEW (CONTINUED)**

Assembly Mnemonic	Assembly Syntax	Description	# of Words	# of Cycles	Status Flags Affected
BTSS	BTSS $f, \#bit4$	Bit Test $f$ , Skip if Set	1	1 (2 or 3)	None
	BTSS $Ws, \#bit4$	Bit Test $Ws$ , Skip if Set	1	1 (2 or 3)	None
BTST	BTST $f, \#bit4$	Bit Test $f$	1	1	Z
	BTST.C $Ws, \#bit4$	Bit Test $Ws$ to C	1	1	C
	BTST.Z $Ws, \#bit4$	Bit Test $Ws$ to Z	1	1	Z
	BTST.C $Ws, Wb$	Bit Test $Ws < Wb >$ to C	1	1	C
	BTST.Z $Ws, Wb$	Bit Test $Ws < Wb >$ to Z	1	1	Z
BTSTS	BTSTS $f, \#bit4$	Bit Test then Set $f$	1	1	Z
	BTSTS.C $Ws, \#bit4$	Bit Test $Ws$ to C, then Set	1	1	C
	BTSTS.Z $Ws, \#bit4$	Bit Test $Ws$ to Z, then Set	1	1	Z
CALL	CALL $lit23$	Call Subroutine	2	2	None
	CALL $Wn$	Call Indirect Subroutine	1	2	None
CLR	CLR $f$	$f = 0x0000$	1	1	None
	CLR $WREG$	$WREG = 0x0000$	1	1	None
	CLR $Ws$	$Ws = 0x0000$	1	1	None
CLRWDT	CLRWDT	Clear Watchdog Timer	1	1	WDTO, Sleep
COM	COM $f$	$f = \bar{f}$	1	1	N, Z
	COM $f, WREG$	$WREG = \bar{f}$	1	1	N, Z
	COM $Ws, Wd$	$Wd = \bar{Ws}$	1	1	N, Z
CP	CP $f$	Compare $f$ with $WREG$	1	1	C, DC, N, OV, Z
	CP $Wb, \#lit5$	Compare $Wb$ with $lit5$	1	1	C, DC, N, OV, Z
	CP $Wb, Ws$	Compare $Wb$ with $Ws$ ( $Wb - Ws$ )	1	1	C, DC, N, OV, Z
CP0	CP0 $f$	Compare $f$ with $0x0000$	1	1	C, DC, N, OV, Z
	CP0 $Ws$	Compare $Ws$ with $0x0000$	1	1	C, DC, N, OV, Z
CPB	CPB $f$	Compare $f$ with $WREG$ , with Borrow	1	1	C, DC, N, OV, Z
	CPB $Wb, \#lit5$	Compare $Wb$ with $lit5$ , with Borrow	1	1	C, DC, N, OV, Z
	CPB $Wb, Ws$	Compare $Wb$ with $Ws$ , with Borrow ( $Wb - Ws - C$ )	1	1	C, DC, N, OV, Z
CPSEQ	CPSEQ $Wb, Wn$	Compare $Wb$ with $Wn$ , Skip if =	1	1 (2 or 3)	None
CPSGT	CPSGT $Wb, Wn$	Compare $Wb$ with $Wn$ , Skip if >	1	1 (2 or 3)	None
CPSLT	CPSLT $Wb, Wn$	Compare $Wb$ with $Wn$ , Skip if <	1	1 (2 or 3)	None
CPSNE	CPSNE $Wb, Wn$	Compare $Wb$ with $Wn$ , Skip if $\neq$	1	1 (2 or 3)	None
DAW	DAW $Wn$	$Wn =$ Decimal Adjust $Wn$	1	1	C
DEC	DEC $f$	$f = f - 1$	1	1	C, DC, N, OV, Z
	DEC $f, WREG$	$WREG = f - 1$	1	1	C, DC, N, OV, Z
	DEC $Ws, Wd$	$Wd = Ws - 1$	1	1	C, DC, N, OV, Z
DEC2	DEC2 $f$	$f = f - 2$	1	1	C, DC, N, OV, Z
	DEC2 $f, WREG$	$WREG = f - 2$	1	1	C, DC, N, OV, Z
	DEC2 $Ws, Wd$	$Wd = Ws - 2$	1	1	C, DC, N, OV, Z
DISI	DISI $\#lit14$	Disable Interrupts for $k$ Instruction Cycles	1	1	None
DIV	DIV.SW $Wm, Wn$	Signed 16/16-bit Integer Divide	1	18	N, Z, C, OV
	DIV.SD $Wm, Wn$	Signed 32/16-bit Integer Divide	1	18	N, Z, C, OV
	DIV.UW $Wm, Wn$	Unsigned 16/16-bit Integer Divide	1	18	N, Z, C, OV
	DIV.UD $Wm, Wn$	Unsigned 32/16-bit Integer Divide	1	18	N, Z, C, OV
EXCH	EXCH $Wns, Wnd$	Swap $Wns$ with $Wnd$	1	1	None
FF1L	FF1L $Ws, Wnd$	Find First One from Left (MSb) Side	1	1	C
FF1R	FF1R $Ws, Wnd$	Find First One from Right (LSb) Side	1	1	C

# PIC24F16KA102 FAMILY

**TABLE 28-2: INSTRUCTION SET OVERVIEW (CONTINUED)**

Assembly Mnemonic	Assembly Syntax	Description	# of Words	# of Cycles	Status Flags Affected
GOTO	GOTO Expr	Go to Address	2	2	None
	GOTO Wn	Go to Indirect	1	2	None
INC	INC f	$f = f + 1$	1	1	C, DC, N, OV, Z
	INC f, WREG	WREG = $f + 1$	1	1	C, DC, N, OV, Z
	INC Ws, Wd	Wd = Ws + 1	1	1	C, DC, N, OV, Z
INC2	INC2 f	$f = f + 2$	1	1	C, DC, N, OV, Z
	INC2 f, WREG	WREG = $f + 2$	1	1	C, DC, N, OV, Z
	INC2 Ws, Wd	Wd = Ws + 2	1	1	C, DC, N, OV, Z
IOR	IOR f	$f = f .IOR. WREG$	1	1	N, Z
	IOR f, WREG	WREG = $f .IOR. WREG$	1	1	N, Z
	IOR #lit10, Wn	Wd = lit10 .IOR. Wd	1	1	N, Z
	IOR Wb, Ws, Wd	Wd = Wb .IOR. Ws	1	1	N, Z
	IOR Wb, #lit5, Wd	Wd = Wb .IOR. lit5	1	1	N, Z
LNK	LNK #lit14	Link Frame Pointer	1	1	None
LSR	LSR f	$f = \text{Logical Right Shift } f$	1	1	C, N, OV, Z
	LSR f, WREG	WREG = Logical Right Shift f	1	1	C, N, OV, Z
	LSR Ws, Wd	Wd = Logical Right Shift Ws	1	1	C, N, OV, Z
	LSR Wb, Wns, Wnd	Wnd = Logical Right Shift Wb by Wns	1	1	N, Z
	LSR Wb, #lit5, Wnd	Wnd = Logical Right Shift Wb by lit5	1	1	N, Z
MOV	MOV f, Wn	Move f to Wn	1	1	None
	MOV [Wns+Slit10], Wnd	Move [Wns+Slit10] to Wnd	1	1	None
	MOV f	Move f to f	1	1	N, Z
	MOV f, WREG	Move f to WREG	1	1	N, Z
	MOV #lit16, Wn	Move 16-bit Literal to Wn	1	1	None
	MOV.b #lit8, Wn	Move 8-bit Literal to Wn	1	1	None
	MOV Wn, f	Move Wn to f	1	1	None
	MOV Wns, [Wns+Slit10]	Move Wns to [Wns+Slit10]	1	1	None
	MOV Wso, Wdo	Move Ws to Wd	1	1	None
	MOV WREG, f	Move WREG to f	1	1	N, Z
	MOV.D Wns, Wd	Move Double from W(ns):W(ns+1) to Wd	1	2	None
	MOV.D Ws, Wnd	Move Double from Ws to W(nd+1):W(nd)	1	2	None
MUL	MUL.SS Wb, Ws, Wnd	$\{Wnd+1, Wnd\} = \text{Signed}(Wb) * \text{Signed}(Ws)$	1	1	None
	MUL.SU Wb, Ws, Wnd	$\{Wnd+1, Wnd\} = \text{Signed}(Wb) * \text{Unsigned}(Ws)$	1	1	None
	MUL.US Wb, Ws, Wnd	$\{Wnd+1, Wnd\} = \text{Unsigned}(Wb) * \text{Signed}(Ws)$	1	1	None
	MUL.UU Wb, Ws, Wnd	$\{Wnd+1, Wnd\} = \text{Unsigned}(Wb) * \text{Unsigned}(Ws)$	1	1	None
	MUL.SU Wb, #lit5, Wnd	$\{Wnd+1, Wnd\} = \text{Signed}(Wb) * \text{Unsigned}(lit5)$	1	1	None
	MUL.UU Wb, #lit5, Wnd	$\{Wnd+1, Wnd\} = \text{Unsigned}(Wb) * \text{Unsigned}(lit5)$	1	1	None
	MUL f	W3:W2 = $f * WREG$	1	1	None
NEG	NEG f	$f = \bar{f} + 1$	1	1	C, DC, N, OV, Z
	NEG f, WREG	WREG = $\bar{f} + 1$	1	1	C, DC, N, OV, Z
	NEG Ws, Wd	Wd = $\overline{Ws} + 1$	1	1	C, DC, N, OV, Z
NOP	NOP	No Operation	1	1	None
	NOPR	No Operation	1	1	None
POP	POP f	Pop f from Top-of-Stack (TOS)	1	1	None
	POP Wdo	Pop from Top-of-Stack (TOS) to Wdo	1	1	None
	POP.D Wnd	Pop from Top-of-Stack (TOS) to W(nd):W(nd+1)	1	2	None
	POP.S	Pop Shadow Registers	1	1	All
PUSH	PUSH f	Push f to Top-of-Stack (TOS)	1	1	None
	PUSH Wso	Push Wso to Top-of-Stack (TOS)	1	1	None
	PUSH.D Wns	Push W(ns):W(ns+1) to Top-of-Stack (TOS)	1	2	None
	PUSH.S	Push Shadow Registers	1	1	None

# PIC24F16KA102 FAMILY

**TABLE 28-2: INSTRUCTION SET OVERVIEW (CONTINUED)**

Assembly Mnemonic	Assembly Syntax	Description	# of Words	# of Cycles	Status Flags Affected
PWRSVAV	PWRSVAV #lit1	Go into Sleep or Idle mode	1	1	WDTO, Sleep
RCALL	RCALL Expr	Relative Call	1	2	None
	RCALL Wn	Computed Call	1	2	None
REPEAT	REPEAT #lit14	Repeat Next Instruction lit14 + 1 times	1	1	None
	REPEAT Wn	Repeat Next Instruction (Wn) + 1 times	1	1	None
RESET	RESET	Software Device Reset	1	1	None
RETFIE	RETFIE	Return from Interrupt	1	3 (2)	None
RETLW	RETLW #lit10, Wn	Return with Literal in Wn	1	3 (2)	None
RETURN	RETURN	Return from Subroutine	1	3 (2)	None
RLC	RLC f	f = Rotate Left through Carry f	1	1	C, N, Z
	RLC f, WREG	WREG = Rotate Left through Carry f	1	1	C, N, Z
	RLC Ws, Wd	Wd = Rotate Left through Carry Ws	1	1	C, N, Z
RLNC	RLNC f	f = Rotate Left (No Carry) f	1	1	N, Z
	RLNC f, WREG	WREG = Rotate Left (No Carry) f	1	1	N, Z
	RLNC Ws, Wd	Wd = Rotate Left (No Carry) Ws	1	1	N, Z
RRC	RRC f	f = Rotate Right through Carry f	1	1	C, N, Z
	RRC f, WREG	WREG = Rotate Right through Carry f	1	1	C, N, Z
	RRC Ws, Wd	Wd = Rotate Right through Carry Ws	1	1	C, N, Z
RRNC	RRNC f	f = Rotate Right (No Carry) f	1	1	N, Z
	RRNC f, WREG	WREG = Rotate Right (No Carry) f	1	1	N, Z
	RRNC Ws, Wd	Wd = Rotate Right (No Carry) Ws	1	1	N, Z
SE	SE Ws, Wnd	Wnd = Sign-Extended Ws	1	1	C, N, Z
SETM	SETM f	f = FFFFh	1	1	None
	SETM WREG	WREG = FFFFh	1	1	None
	SETM Ws	Ws = FFFFh	1	1	None
SL	SL f	f = Left Shift f	1	1	C, N, OV, Z
	SL f, WREG	WREG = Left Shift f	1	1	C, N, OV, Z
	SL Ws, Wd	Wd = Left Shift Ws	1	1	C, N, OV, Z
	SL Wb, Wns, Wnd	Wnd = Left Shift Wb by Wns	1	1	N, Z
	SL Wb, #lit5, Wnd	Wnd = Left Shift Wb by lit5	1	1	N, Z
SUB	SUB f	f = f - WREG	1	1	C, DC, N, OV, Z
	SUB f, WREG	WREG = f - WREG	1	1	C, DC, N, OV, Z
	SUB #lit10, Wn	Wn = Wn - lit10	1	1	C, DC, N, OV, Z
	SUB Wb, Ws, Wd	Wd = Wb - Ws	1	1	C, DC, N, OV, Z
	SUB Wb, #lit5, Wd	Wd = Wb - lit5	1	1	C, DC, N, OV, Z
SUBB	SUBB f	f = f - WREG - ( $\overline{C}$ )	1	1	C, DC, N, OV, Z
	SUBB f, WREG	WREG = f - WREG - ( $\overline{C}$ )	1	1	C, DC, N, OV, Z
	SUBB #lit10, Wn	Wn = Wn - lit10 - ( $\overline{C}$ )	1	1	C, DC, N, OV, Z
	SUBB Wb, Ws, Wd	Wd = Wb - Ws - ( $\overline{C}$ )	1	1	C, DC, N, OV, Z
	SUBB Wb, #lit5, Wd	Wd = Wb - lit5 - ( $\overline{C}$ )	1	1	C, DC, N, OV, Z
SUBR	SUBR f	f = WREG - f	1	1	C, DC, N, OV, Z
	SUBR f, WREG	WREG = WREG - f	1	1	C, DC, N, OV, Z
	SUBR Wb, Ws, Wd	Wd = Ws - Wb	1	1	C, DC, N, OV, Z
	SUBR Wb, #lit5, Wd	Wd = lit5 - Wb	1	1	C, DC, N, OV, Z
SUBBR	SUBBR f	f = WREG - f - ( $\overline{C}$ )	1	1	C, DC, N, OV, Z
	SUBBR f, WREG	WREG = WREG - f - ( $\overline{C}$ )	1	1	C, DC, N, OV, Z
	SUBBR Wb, Ws, Wd	Wd = Ws - Wb - ( $\overline{C}$ )	1	1	C, DC, N, OV, Z
	SUBBR Wb, #lit5, Wd	Wd = lit5 - Wb - ( $\overline{C}$ )	1	1	C, DC, N, OV, Z
SWAP	SWAP.b Wn	Wn = Nibble Swap Wn	1	1	None
	SWAP Wn	Wn = Byte Swap Wn	1	1	None
TBLRDH	TBLRDH Ws, Wd	Read Prog<23:16> to Wd<7:0>	1	2	None

# PIC24F16KA102 FAMILY

**TABLE 28-2: INSTRUCTION SET OVERVIEW (CONTINUED)**

Assembly Mnemonic	Assembly Syntax	Description	# of Words	# of Cycles	Status Flags Affected
TBLRDL	TBLRDL Ws, Wd	Read Prog<15:0> to Wd	1	2	None
TBLWTH	TBLWTH Ws, Wd	Write Ws<7:0> to Prog<23:16>	1	2	None
TBLWTL	TBLWTL Ws, Wd	Write Ws to Prog<15:0>	1	2	None
ULNK	ULNK	Unlink Frame Pointer	1	1	None
XOR	XOR f	f = f .XOR. WREG	1	1	N, Z
	XOR f, WREG	WREG = f .XOR. WREG	1	1	N, Z
	XOR #lit10, Wn	Wd = lit10 .XOR. Wd	1	1	N, Z
	XOR Wb, Ws, Wd	Wd = Wb .XOR. Ws	1	1	N, Z
	XOR Wb, #lit5, Wd	Wd = Wb .XOR. lit5	1	1	N, Z
ZE	ZE Ws, Wnd	Wnd = Zero-Extend Ws	1	1	C, Z, N

# PIC24F16KA102 FAMILY

---

NOTES:

# PIC24F16KA102 FAMILY

## 29.0 ELECTRICAL CHARACTERISTICS

This section provides an overview of the PIC24F16KA102 family electrical characteristics. Additional information will be provided in future revisions of this document as it becomes available.

Absolute maximum ratings for the PIC24F16KA102 family are listed below. Exposure to these maximum rating conditions for extended periods may affect device reliability. Functional operation of the device at these, or any other conditions above the parameters indicated in the operation listings of this specification, is not implied.

### Absolute Maximum Ratings<sup>(†)</sup>

Ambient temperature under bias .....	-40°C to +125°C
Storage temperature .....	-65°C to +175°C
Voltage on VDD with respect to VSS .....	-0.3V to +5.0V
Voltage on any combined analog and digital pin, with respect to VSS .....	-0.3V to (VDD + 0.3V)
Voltage on any digital only pin with respect to VSS .....	-0.3V to (VDD + 0.3V)
Voltage on $\overline{MCLR}/VPP$ pin with respect to VSS .....	-0.3V to +9.0V
Maximum current out of VSS pin .....	300 mA
Maximum current into VDD pin <sup>(1)</sup> .....	250 mA
Maximum output current sunk by any I/O pin.....	25 mA
Maximum output current sourced by any I/O pin .....	25 mA
Maximum current sunk by all ports .....	200 mA
Maximum current sourced by all ports <sup>(1)</sup> .....	200 mA

**Note 1:** Maximum allowable current is a function of device maximum power dissipation (see [Table 29-1](#)).

† **NOTICE:** Stresses above those listed under "Absolute Maximum Ratings" may cause permanent damage to the device. This is a stress rating only and functional operation of the device at those or any other conditions above those indicated in the operation listings of this specification is not implied. Exposure to maximum rating conditions for extended periods may affect device reliability.

# PIC24F16KA102 FAMILY

## 29.1 DC Characteristics

FIGURE 29-1: PIC24F16KA102 FAMILY VOLTAGE-FREQUENCY GRAPH (INDUSTRIAL)



FIGURE 29-2: PIC24F16KA102 FAMILY VOLTAGE-FREQUENCY GRAPH (INDUSTRIAL, EXTENDED)





# PIC24F16KA102 FAMILY

**TABLE 29-1: THERMAL OPERATING CONDITIONS**

Rating	Symbol	Min	Typ	Max	Unit
Operating Junction Temperature Range	T <sub>J</sub>	-40	—	+175	°C
Operating Ambient Temperature Range	T <sub>A</sub>	-40	—	+125	°C
Power Dissipation: Internal Chip Power Dissipation: $P_{INT} = V_{DD} \times (I_{DD} - \sum I_{OH})$ I/O Pin Power Dissipation: $P_{I/O} = \sum (\{V_{DD} - V_{OH}\} \times I_{OH}) + \sum (V_{OL} \times I_{OL})$	P <sub>D</sub>	P <sub>INT</sub> + P <sub>I/O</sub>			W
Maximum Allowed Power Dissipation	P <sub>D</sub> MAX	$(T_J - T_A)/\theta_{JA}$			W

**TABLE 29-2: THERMAL PACKAGING CHARACTERISTICS**

Characteristic	Symbol	Typ	Max	Unit	Notes
Package Thermal Resistance, 20-Pin PDIP	$\theta_{JA}$	62.4	—	°C/W	1
Package Thermal Resistance, 28-Pin SPDIP	$\theta_{JA}$	60	—	°C/W	1
Package Thermal Resistance, 20-Pin SSOP	$\theta_{JA}$	108	—	°C/W	1
Package Thermal Resistance, 28-Pin SSOP	$\theta_{JA}$	71	—	°C/W	1
Package Thermal Resistance, 20-Pin SOIC	$\theta_{JA}$	75	—	°C/W	1
Package Thermal Resistance, 28-Pin SOIC	$\theta_{JA}$	80.2	—	°C/W	1
Package Thermal Resistance, 20-Pin QFN	$\theta_{JA}$	43	—	°C/W	1
Package Thermal Resistance, 28-Pin QFN	$\theta_{JA}$	32	—	°C/W	1

**Note 1:** Junction to ambient thermal resistance, Theta-JA ( $\theta_{JA}$ ) numbers are achieved by package simulations.

# PIC24F16KA102 FAMILY

**TABLE 29-3: DC CHARACTERISTICS: TEMPERATURE AND VOLTAGE SPECIFICATIONS**

DC CHARACTERISTICS			Standard Operating Conditions: 1.8V to 3.6V (unless otherwise stated)				
			Operating temperature -40°C ≤ TA ≤ +85°C for Industrial -40°C ≤ TA ≤ +125°C for Extended				
Param No.	Symbol	Characteristic	Min	Typ <sup>(1)</sup>	Max	Units	Conditions
DC10	VDD	Supply Voltage	1.8	—	3.6	V	
DC12	VDR	RAM Data Retention Voltage <sup>(2)</sup>	1.5	—	—	V	
DC16	VPOR	VDD Start Voltage to Ensure Internal Power-on Reset Signal	VSS	—	0.7	V	
DC17	SVDD	VDD Rise Rate to Ensure Internal Power-on Reset Signal	0.05	—	—	V/ms	0-3.3V in 0.1s 0-2.5V in 60 ms

**Note 1:** Data in “Typ” column is at 3.3V, 25°C unless otherwise stated. Parameters are for design guidance only and are not tested.

**2:** This is the limit to which VDD can be lowered without losing RAM data.

**TABLE 29-4: HIGH/LOW-VOLTAGE DETECT CHARACTERISTICS**

Standard Operating Conditions (unless otherwise stated)								
Operating temperature -40°C ≤ TA ≤ +85°C for industrial -40°C ≤ TA ≤ +125°C for Extended								
Param No.	Symbol	Characteristic	Min	Typ	Max	Units	Conditions	
DC18	VHLVD	HLVD Voltage on VDD Transition	HLVDL<3:0> = 0000	—	1.85	1.94	V	
			HLVDL<3:0> = 0001	1.81	1.90	2.00	V	
			HLVDL<3:0> = 0010	1.85	1.95	2.05	V	
			HLVDL<3:0> = 0011	1.90	2.00	2.10	V	
			HLVDL<3:0> = 0100	1.95	2.05	2.15	V	
			HLVDL<3:0> = 0101	2.06	2.17	2.28	V	
			HLVDL<3:0> = 0110	2.12	2.23	2.34	V	
			HLVDL<3:0> = 0111	2.24	2.36	2.48	V	
			HLVDL<3:0> = 1000	2.31	2.43	2.55	V	
			HLVDL<3:0> = 1001	2.47	2.60	2.73	V	
			HLVDL<3:0> = 1010	2.64	2.78	2.92	V	
			HLVDL<3:0> = 1011	2.74	2.88	3.02	V	
			HLVDL<3:0> = 1100	2.85	3.00	3.15	V	
			HLVDL<3:0> = 1101	2.96	3.12	3.28	V	
HLVDL<3:0> = 1110	3.22	3.39	3.56	V				

# PIC24F16KA102 FAMILY

**FIGURE 29-3: BROWN-OUT RESET CHARACTERISTICS**



**TABLE 29-5: BOR TRIP POINTS**

Standard Operating Conditions (unless otherwise stated)								
Operating temperature $-40^{\circ}\text{C} \leq T_A \leq +85^{\circ}\text{C}$ for industrial								
$-40^{\circ}\text{C} \leq T_A \leq +125^{\circ}\text{C}$ for Extended								
Param No.	Sym	Characteristic	Min	Typ	Max	Units	Conditions	
DC19	VBOR	BOR Voltage on VDD Transition	BOR = 00	—	—	—	—	LPBOR <sup>(1)</sup>
			BOR = 01	2.92	3	3.08	V	
			BOR = 10	2.63	2.7	2.77	V	
			BOR = 11	1.75	1.82	1.85	V	
DC14	VBHYS	BOR Hysteresis	—	5	—	mV		

**Note 1:** LPBOR re-arms the POR circuit, but does not cause a BOR. LPBOR can be used to ensure a POR after the supply voltage rises to a safe operating level. It does not stop code execution after the supply voltage falls below a chosen trip point.

# PIC24F16KA102 FAMILY

**TABLE 29-6: DC CHARACTERISTICS: OPERATING CURRENT (IDD)**

DC CHARACTERISTICS			Standard Operating Conditions: 1.8V to 3.6V (unless otherwise stated)			
			Operating temperature -40°C ≤ TA ≤ +85°C for Industrial -40°C ≤ TA ≤ +125°C for Extended			
Parameter No.	Typical <sup>(1)</sup>	Max	Units	Conditions		
<b>IDD Current<sup>(2)</sup></b>						
DC20	195	330	μA	-40°C	1.8V	0.5 MIPS, FOSC = 1 MHz
DS20a		330		+25°C		
DC20b		330		+60°C		
DC20c		330		+85°C		
DC20d		500		+125°C		
DC20e	365	590	μA	-40°C	3.3V	
DC20f		590		+25°C		
DC20g		645		+60°C		
DC20h		720		+85°C		
DC20i		800		+125°C		
DC22	363	600	μA	-40°C	1.8V	1 MIPS, FOSC = 2 MHz
DC22a		600		+25°C		
DC22b		600		+60°C		
DC22c		600		+85°C		
DC22d		800		+125°C		
DC22e	695	1100	μA	-40°C	3.3V	
DC22f		1100		+25°C		
DC22g		1100		+60°C		
DC22h		1100		+85°C		
DC22i		1500		+125°C		
DC23	11	18	mA	-40°C	3.3V	16 MIPS, Fosc = 32 MHz
DC23a		18		+25°C		
DC23b		18		+60°C		
DC23c		18		+85°C		
DC23d		18		+125°C		
DC27	2.25	3.40	mA	-40°C	2.5V	FRC (4 MIPS), FOSC = 8 MHz
DC27a		3.40		+25°C		
DC27b		3.40		+60°C		
DC27c		3.40		+85°C		
DC27d		3.40		+125°C		
DC27e	3.05	4.60	mA	-40°C	3.3V	
DC27f		4.60		+25°C		
DC27g		4.60		+60°C		
DC27h		4.60		+85°C		
DC27i		5.40		+125°C		

**Note 1:** Data in "Typical" column is at 3.3V, 25°C unless otherwise stated. Parameters are for design guidance only and are not tested.

**2: Operating Parameters:**

- EC mode with clock input driven with a square wave rail-to-rail
- I/Os are configured as outputs, driven low
- $\overline{\text{MCLR}} - V_{DD}$
- WDT FSCM is disabled
- SRAM, program and data memory are active
- All PMD bits are set except for modules being measured

# PIC24F16KA102 FAMILY

**TABLE 29-6: DC CHARACTERISTICS: OPERATING CURRENT (IDD) (CONTINUED)**

DC CHARACTERISTICS			Standard Operating Conditions: 1.8V to 3.6V (unless otherwise stated)			
			Operating temperature -40°C ≤ TA ≤ +85°C for Industrial -40°C ≤ TA ≤ +125°C for Extended			
Parameter No.	Typical <sup>(1)</sup>	Max	Units	Conditions		
<b>IDD Current<sup>(2)</sup></b>						
DC31	8	28	μA	-40°C	1.8V	LPRC (31 kHz)
DC31a		28		+25°C		
DC31b		28		+60°C		
DC31c		28		+85°C		
DC31d	15	55	μA	-40°C	3.3V	
DC31e		55		+25°C		
DC31f		55		+60°C		
DC31g		55		+85°C		
DC31h		250		+125°C		

**Note 1:** Data in "Typical" column is at 3.3V, 25°C unless otherwise stated. Parameters are for design guidance only and are not tested.

**2: Operating Parameters:**

- EC mode with clock input driven with a square wave rail-to-rail
- I/Os are configured as outputs, driven low
- MCLR – VDD
- WDT FSCM is disabled
- SRAM, program and data memory are active
- All PMD bits are set except for modules being measured

# PIC24F16KA102 FAMILY

**TABLE 29-7: DC CHARACTERISTICS: IDLE CURRENT (IDLE)**

DC CHARACTERISTICS			Standard Operating Conditions: 1.8V to 3.6V (unless otherwise stated)			
			Operating temperature -40°C ≤ TA ≤ +85°C for Industrial -40°C ≤ TA ≤ +125°C for Extended			
Param No.	Typical <sup>(1)</sup>	Max	Units	Conditions		
<b>Idle Current (IDLE): Core Off, Clock on Base Current, PMD Bits are Set<sup>(2)</sup></b>						
DC40	48	100	μA	-40°C	1.8V	0.5 MIPS, Fosc = 1 MHz
DC40a		100		+25°C		
DC40b		100		+60°C		
DC40c		100		+85°C		
DC40d		100		+125°C		
DC40e	106	215	μA	-40°C	3.3V	
DC40f		215		+25°C		
DC40g		215		+60°C		
DC40h		215		+85°C		
DC40i		450		+125°C		
DC42	94	200	μA	-40°C	1.8V	1 MIPS, Fosc = 2 MHz
DC42a		200		+25°C		
DC42b		200		+60°C		
DC42c		200		+85°C		
DC42d		300		+125°C		
DC42e	160	395	μA	-40°C	3.3V	
DC42f		395		+25°C		
DC42g		395		+60°C		
DC42h		395		+85°C		
DC42i		600		+125°C		
DC43	3.1	6.0	mA	-40°C	3.3V	16 MIPS, Fosc = 32 MHz
DC43a		6.0		+25°C		
DC43b		6.0		+60°C		
DC43c		6.0		+85°C		
DC43d		6.0		+125°C		
DC44	0.56	0.74	mA	-40°C	1.8V	FRC (4 MIPS), Fosc = 8 MHz
DC44a		0.74		+25°C		
DC44b		0.74		+60°C		
DC44c		0.74		+85°C		
DC44d		0.74		+125°C		
DC44e	0.95	1.50	mA	-40°C	3.3V	
DC44f		1.50		+25°C		
DC44g		1.50		+60°C		
DC44h		1.50		+85°C		
DC44i		1.50		+125°C		

**Note 1:** Data in "Typical" column is at 3.3V, 25°C unless otherwise stated. Parameters are for design guidance only and are not tested.

**2:** Operating Parameters:

- Core is off
- EC mode with the clock input driven with a square wave rail-to-rail
- I/Os are configured as outputs, driven low
- MCLR – VDD
- WDT FSCM are disabled
- SRAM, program and data memory are active
- All PMD bits are set except for the modules being measured

# PIC24F16KA102 FAMILY

**TABLE 29-7: DC CHARACTERISTICS: IDLE CURRENT (I<sub>IDLE</sub>) (CONTINUED)**

DC CHARACTERISTICS			Standard Operating Conditions: 1.8V to 3.6V (unless otherwise stated) Operating temperature -40°C ≤ T <sub>A</sub> ≤ +85°C for Industrial -40°C ≤ T <sub>A</sub> ≤ +125°C for Extended			
Param No.	Typical <sup>(1)</sup>	Max	Units	Conditions		
<b>Idle Current (I<sub>IDLE</sub>): Core Off, Clock on Base Current, PMD Bits are Set<sup>(2)</sup></b>						
DC50	2	18	μA	-40°C	1.8V	LPRC (31 kHz)
DC50a		18		+25°C		
DC50b		18		+60°C		
DC50c		18		+85°C		
DC50d	4	40		-40°C	3.3V	
DC50e		40		+25°C		
DC50f		40		+60°C		
DC50g		40		+85°C		
DC50h		60	+125°C			

**Note 1:** Data in “Typical” column is at 3.3V, 25°C unless otherwise stated. Parameters are for design guidance only and are not tested.

**2:** Operating Parameters:

- Core is off
- EC mode with the clock input driven with a square wave rail-to-rail
- I/Os are configured as outputs, driven low
- MCLR – V<sub>DD</sub>
- WDT FSCM are disabled
- SRAM, program and data memory are active
- All PMD bits are set except for the modules being measured

# PIC24F16KA102 FAMILY

**TABLE 29-8: DC CHARACTERISTICS: POWER-DOWN CURRENT (IPD)**

DC CHARACTERISTICS			Standard Operating Conditions: 1.8V to 3.6V (unless otherwise stated)			
			Operating temperature -40°C ≤ TA ≤ +85°C for Industrial -40°C ≤ TA ≤ +125°C for Extended			
Parameter No.	Typical <sup>(1)</sup>	Max	Units	Conditions		
<b>Power-Down Current (IPD): PMD Bits are Set, PMSLP Bit is '0'<sup>(2)</sup></b>						
DC60	0.025	0.200	μA	-40°C	1.8V	Base Power-Down Current (Sleep) <sup>(3)</sup>
DC60a		0.200		+25°C		
DC60b		0.870		+60°C		
DC60c		1.350		+85°C		
DC60d		10.00		+125°C		
DC60e	0.105	0.540	μA	-40°C	3.3V	
DC60f		0.540		+25°C		
DC60g		1.680		+60°C		
DC60h		2.450		+85°C		
DC60i		11.00		+125°C		
DC70	0.020	0.150	μA	-40°C	1.8V	Base Deep Sleep Current
DC70a		0.150		+25°C		
DC70b		0.430		+60°C		
DC70c		0.630		+85°C		
DC70d		3.00		+125°C		
DC70e	0.035	0.300	μA	-40°C	3.3V	
DC70f		0.300		+25°C		
DC70g		0.700		+60°C		
DC70h		0.980		+85°C		
DC70i		5.00		+125°C		
DC61	0.55	0.65	μA	-40°C	1.8V	Watchdog Timer Current (WDT) <sup>(3,4)</sup>
DC61a		0.65		+25°C		
DC61b		0.65		+60°C		
DC61c		0.65		+85°C		
DC61d		1.20		+125°C		
DC61e	0.87	0.95	μA	-40°C	3.3V	
DC61f		0.95		+25°C		
DC61g		0.95		+60°C		
DC61h		0.95		+85°C		
DC61i		1.50		+125°C		

- Note 1:** Data in the "Typical" column is at 3.3V, 25°C unless otherwise stated. Parameters are for design guidance only and are not tested.
- Note 2:** Base IPD is measured with all peripherals and clocks shut down. All I/Os are configured as outputs and set low. WDT, etc., are all switched off.
- Note 3:** The Δ current is the additional current consumed when the module is enabled. This current should be added to the base IPD current.
- Note 4:** Current applies to Sleep only.
- Note 5:** Current applies to Sleep and Deep Sleep.
- Note 6:** Current applies to Deep Sleep only.



# PIC24F16KA102 FAMILY

**TABLE 29-8: DC CHARACTERISTICS: POWER-DOWN CURRENT (IPD) (CONTINUED)**

DC CHARACTERISTICS			Standard Operating Conditions: 1.8V to 3.6V (unless otherwise stated) Operating temperature -40°C ≤ TA ≤ +85°C for Industrial -40°C ≤ TA ≤ +125°C for Extended			
Parameter No.	Typical <sup>(1)</sup>	Max	Units	Conditions		
<b>Power-Down Current (IPD): PMD Bits are Set, PMSLP Bit is '0'<sup>(2)</sup></b>						
DC62	0.450	0.650	μA	-40°C	1.8V	Timer1 w/32 kHz Crystal: T132 (SOSC – LP) <sup>(3)</sup>
DC62a		0.650		+25°C		
DC62b		0.650		+60°C		
DC62c		0.650		+85°C		
DC62d		—		+125°C		
DC62e	0.730	0.980	μA	-40°C	3.3V	
DC62f		0.980		+25°C		
DC62g		0.980		+60°C		
DC62h		0.980		+85°C		
DC62i		—		+125°C		
DC64	5.5	7.10	μA	-40°C	1.8V	HLVD <sup>(3,4)</sup>
DC64a		7.10		+25°C		
DC64b		7.80		+60°C		
DC64c		8.30		+85°C		
DC64d		10.00		+125°C		
DC64e	6.2	7.10	μA	-40°C	3.3V	
DC64f		7.10		+25°C		
DC64g		7.80		+60°C		
DC64h		8.30		+85°C		
DC64i		9.00		+125°C		
DC63	4.5	6.60	μA	-40°C	3.3V	BOR <sup>(3,4)</sup>
DC63a		6.60		+25°C		
DC63b		6.60		+60°C		
DC63c		6.60		+85°C		
DC63d		9.00		+125°C		
DC62	0.49	0.65	μA	-40°C	1.8V	RTCC <sup>(3,5)</sup>
DC62a		0.65		+25°C		
DC62b		0.65		+60°C		
DC62c		0.65		+85°C		
DC62d		0.98		+125°C		
DC62e	0.80	0.98	μA	-40°C	3.3V	
DC62f		0.98		+25°C		
DC62g		0.98		+60°C		
DC62h		0.98		+85°C		
DC62i		0.98		+125°C		

- Note 1:** Data in the “Typical” column is at 3.3V, 25°C unless otherwise stated. Parameters are for design guidance only and are not tested.
- 2:** Base IPD is measured with all peripherals and clocks shut down. All I/Os are configured as outputs and set low. WDT, etc., are all switched off.
- 3:** The Δ current is the additional current consumed when the module is enabled. This current should be added to the base IPD current.
- 4:** Current applies to Sleep only.
- 5:** Current applies to Sleep and Deep Sleep.
- 6:** Current applies to Deep Sleep only.

# PIC24F16KA102 FAMILY

**TABLE 29-8: DC CHARACTERISTICS: POWER-DOWN CURRENT (IPD) (CONTINUED)**

DC CHARACTERISTICS			Standard Operating Conditions: 1.8V to 3.6V (unless otherwise stated) Operating temperature -40°C ≤ TA ≤ +85°C for Industrial -40°C ≤ TA ≤ +125°C for Extended			
Parameter No.	Typical <sup>(1)</sup>	Max	Units	Conditions		
<b>Power-Down Current (IPD): PMD Bits are Set, PMSLP Bit is '0'<sup>(2)</sup></b>						
DC70	0.045	0.200	μA	-40°C	1.8V	LPBOR <sup>(3,4)</sup>
DC70a		0.200		+25°C		
DC70b		0.200		+60°C		
DC70c		0.200		+85°C		
DC70d		1.45		+125°C		
DC70e	0.095	0.200	μA	-40°C	3.3V	
DC70f		0.200		+25°C		
DC70g		0.200		+60°C		
DC70h		0.200		+85°C		
DC70i		1.55		+125°C		
DC71	0.35	0.55	μA	-40°C	1.8V	Deep Sleep Watchdog Timer: DSWDT (SOSC – LP) <sup>(6)</sup>
DC71a		0.55		+25°C		
DC71b		0.55		+60°C		
DC71c		0.55		+85°C		
DC71d	0.55	1.70	μA	+125°C	3.3V	
DC71e		0.75		-40°C		
DC71f		0.75		+25°C		
DC71g		0.75		+60°C		
DC71h		0.75		+85°C		
DC71i	2.10	+125°C				
DC72	0.005	0.200	μA	-40°C	1.8V	Deep Sleep BOR (DSBOR) <sup>(6)</sup>
DC72a		0.200		+25°C		
DC72b		0.200		+60°C		
DC72c		0.200		+85°C		
DC72d		0.200		+125°C		
DC72e	0.010	0.200	μA	-40°C	3.3V	
DC72f		0.200		+25°C		
DC72g		0.200		+60°C		
DC72h		0.200		+85°C		
DC72i		0.200		+125°C		

- Note 1:** Data in the “Typical” column is at 3.3V, 25°C unless otherwise stated. Parameters are for design guidance only and are not tested.
- 2:** Base IPD is measured with all peripherals and clocks shut down. All I/Os are configured as outputs and set low. WDT, etc., are all switched off.
- 3:** The Δ current is the additional current consumed when the module is enabled. This current should be added to the base IPD current.
- 4:** Current applies to Sleep only.
- 5:** Current applies to Sleep and Deep Sleep.
- 6:** Current applies to Deep Sleep only.

# PIC24F16KA102 FAMILY

**TABLE 29-9: DC CHARACTERISTICS: I/O PIN INPUT SPECIFICATIONS**

DC CHARACTERISTICS			Standard Operating Conditions: 1.8V to 3.6V (unless otherwise stated) Operating temperature -40°C ≤ TA ≤ +85°C for Industrial -40°C ≤ TA ≤ +125°C for Extended				
Param No.	Sym	Characteristic	Min	Typ <sup>(1)</sup>	Max	Units	Conditions
	V <sub>IL</sub>	<b>Input Low Voltage<sup>(4)</sup></b>	—	—	—	—	
DI10		I/O Pins	V <sub>SS</sub>	—	0.2 V <sub>DD</sub>	V	
DI15		$\overline{\text{MCLR}}$	V <sub>SS</sub>	—	0.2 V <sub>DD</sub>	V	
DI16		OSCI (XT mode)	V <sub>SS</sub>	—	0.2 V <sub>DD</sub>	V	
DI17		OSCI (HS mode)	V <sub>SS</sub>	—	0.2 V <sub>DD</sub>	V	
DI18		I/O Pins with I <sup>2</sup> C™ Buffer	V <sub>SS</sub>	—	0.3 V <sub>DD</sub>	V	SMBus disabled
DI19		I/O Pins with SMBus Buffer	V <sub>SS</sub>	—	0.8	V	SMBus enabled
	V <sub>IH</sub> <sup>(5)</sup>	<b>Input High Voltage<sup>(4)</sup></b>	—	—	—	—	
DI20		I/O Pins: with Analog Functions	0.8 V <sub>DD</sub>	—	V <sub>DD</sub>	V	
		Digital Only	0.8 V <sub>DD</sub>	—	V <sub>DD</sub>	V	
DI25		$\overline{\text{MCLR}}$	0.8 V <sub>DD</sub>	—	V <sub>DD</sub>	V	
DI26		OSCI (XT mode)	0.7 V <sub>DD</sub>	—	V <sub>DD</sub>	V	
DI27		OSCI (HS mode)	0.7 V <sub>DD</sub>	—	V <sub>DD</sub>	V	
DI28		I/O Pins with I <sup>2</sup> C Buffer: with Analog Functions	0.7 V <sub>DD</sub>	—	V <sub>DD</sub>	V	
		Digital Only	0.7 V <sub>DD</sub>	—	V <sub>DD</sub>	V	
DI29		I/O Pins with SMBus	2.1	—	V <sub>DD</sub>	V	2.5V ≤ V <sub>PIN</sub> ≤ V <sub>DD</sub>
DI30	ICNPU	<b>CN<sub>x</sub> Pull-up Current</b>	50	250	500	μA	V <sub>DD</sub> = 3.3V, V <sub>PIN</sub> = V <sub>SS</sub>
	I <sub>IL</sub>	<b>Input Leakage Current<sup>(2,3)</sup></b>					
DI50		I/O Ports	—	0.050	±0.100	μA	V <sub>SS</sub> ≤ V <sub>PIN</sub> ≤ V <sub>DD</sub> , Pin at high-impedance
DI51		V <sub>REF+</sub> , V <sub>REF-</sub> , AN0, AN1	—	0.300	±0.500	μA	V <sub>SS</sub> ≤ V <sub>PIN</sub> ≤ V <sub>DD</sub> , Pin at high-impedance
DI55		$\overline{\text{MCLR}}$	—	—	±5.0	μA	V <sub>SS</sub> ≤ V <sub>PIN</sub> ≤ V <sub>DD</sub>
DI56		OSCI	—	—	±5.0	μA	V <sub>SS</sub> ≤ V <sub>PIN</sub> ≤ V <sub>DD</sub> , XT and HS modes

- Note 1:** Data in “Typ” column is at 3.3V, 25°C unless otherwise stated. Parameters are for design guidance only and are not tested.
- 2:** The leakage current on the  $\overline{\text{MCLR}}$  pin is strongly dependent on the applied voltage level. The specified levels represent normal operating conditions. Higher leakage current may be measured at different input voltages.
- 3:** Negative current is defined as current sourced by the pin.
- 4:** Refer to [Table 1-2](#) for I/O pin buffer types.
- 5:** V<sub>IH</sub> requirements are met when internal pull-ups are enabled.

# PIC24F16KA102 FAMILY

**TABLE 29-10: DC CHARACTERISTICS: I/O PIN OUTPUT SPECIFICATIONS**

DC CHARACTERISTICS			Standard Operating Conditions: 1.8V to 3.6V (unless otherwise stated)				
			Operating temperature -40°C ≤ TA ≤ +85°C for Industrial -40°C ≤ TA ≤ +125°C for Extended				
Param No.	Sym	Characteristic	Min	Typ <sup>(1)</sup>	Max	Units	Conditions
DO10	VOL	<b>Output Low Voltage</b> All I/O Pins	—	—	0.4	V	IOL = 4.0 mA, VDD = 3.6V
			—	—	0.4	V	IOL = 3.5 mA, VDD = 2.0V
DO16		OSC2/CLKO	—	—	0.4	V	IOL = 8.0 mA, VDD = 3.6V
			—	—	0.4	V	IOL = 4.5 mA, VDD = 1.8V
DO20	VOH	<b>Output High Voltage</b> All I/O Pins	3	—	—	V	IOH = -3.0 mA, VDD = 3.6V
			1.8	—	—	V	IOH = -1.0 mA, VDD = 2.0V
DO26		OSC2/CLKO	3	—	—	V	IOH = -2.5 mA, VDD = 3.6V
			1.8	—	—	V	IOH = -1.0 mA, VDD = 2.0V

**Note 1:** Data in "Typ" column is at 25°C unless otherwise stated. Parameters are for design guidance only and are not tested.

# PIC24F16KA102 FAMILY

**TABLE 29-11: DC CHARACTERISTICS: PROGRAM MEMORY**

DC CHARACTERISTICS			Standard Operating Conditions: 1.8V to 3.6V (unless otherwise stated) Operating temperature -40°C ≤ TA ≤ +85°C for Industrial -40°C ≤ TA ≤ +125°C for Extended				
Param No.	Sym	Characteristic	Min	Typ <sup>(1)</sup>	Max	Units	Conditions
<b>Program Flash Memory</b>							
D130	EP	Cell Endurance	10,000 <sup>(2)</sup>	—	—	E/W	V <sub>MIN</sub> = Minimum operating voltage Provided no other specifications are violated
D131	VPR	VDD for Read	V <sub>MIN</sub>	—	3.6	V	
D133A	TIW	Self-Timed Write Cycle Time	—	2	—	ms	
D134	TRETD	Characteristic Retention	40	—	—	Year	
D135	IDDP	Supply Current During Programming	—	10	—	mA	

**Note 1:** Data in "Typ" column is at 3.3V, 25°C unless otherwise stated.

**Note 2:** Self-write and block erase.

**TABLE 29-12: DC CHARACTERISTICS: DATA EEPROM MEMORY**

DC CHARACTERISTICS			Standard Operating Conditions: 1.8V to 3.6V (unless otherwise stated) Operating temperature -40°C ≤ TA ≤ +85°C for Industrial -40°C ≤ TA ≤ +125°C for Extended				
Param No.	Sym	Characteristic	Min	Typ <sup>(1)</sup>	Max	Units	Conditions
<b>Data EEPROM Memory</b>							
D140	EPD	Cell Endurance	100,000	—	—	E/W	V <sub>MIN</sub> = Minimum operating voltage
D141	VPRD	VDD for Read	V <sub>MIN</sub>	—	3.6	V	
D143A	TIWD	Self-Timed Write Cycle Time	—	4	—	ms	
D143B	TREF	Number of Total Write/Erase Cycles Before Refresh	—	10M	—	E/W	Provided no other specifications are violated
D144	TRETD	Characteristic Retention	40	—	—	Year	
D145	IDDPD	Supply Current During Programming	—	7	—	mA	

**Note 1:** Data in "Typ" column is at 3.3V, 25°C unless otherwise stated.

# PIC24F16KA102 FAMILY

**TABLE 29-13: COMPARATOR DC SPECIFICATIONS**

Operating Conditions: 2.0V < VDD < 3.6V Operating temperature -40°C ≤ TA ≤ +85°C for Industrial -40°C ≤ TA ≤ +125°C for Extended							
Param No.	Symbol	Characteristic	Min	Typ	Max	Units	Comments
D300	VIOFF	Input Offset Voltage*	—	20	40	mV	
D301	VICM	Input Common Mode Voltage*	0	—	VDD	V	
D302	CMRR	Common Mode Rejection Ratio*	55	—	—	dB	

\* Parameters are characterized but not tested.

**TABLE 29-14: COMPARATOR VOLTAGE REFERENCE DC SPECIFICATIONS**

Operating Conditions: 2.0V < VDD < 3.6V Operating temperature -40°C ≤ TA ≤ +85°C for Industrial -40°C ≤ TA ≤ +125°C for Extended							
Param No.	Symbol	Characteristic	Min	Typ	Max	Units	Comments
VRD310	CVRES	Resolution	VDD/24	—	VDD/32	LSb	
VRD311	CVRAA	Absolute Accuracy	—	—	AVDD – 1.5	LSb	
VRD312	CVRUR	Unit Resistor Value (R)	—	2k	—	Ω	

**TABLE 29-15: INTERNAL VOLTAGE REFERENCES**

Operating Conditions: 2.0V < VDD < 3.6V Operating temperature -40°C ≤ TA ≤ +85°C for Industrial -40°C ≤ TA ≤ +125°C for Extended							
Param No.	Symbol	Characteristic	Min	Typ	Max	Units	Comments
	VBG	Internal Band Gap Reference	1.14	1.2	1.26	V	
	TIRVST	Internal Reference Stabilization Time	—	200	250	μs	

**TABLE 29-16: CTMU CURRENT SOURCE SPECIFICATIONS**

DC CHARACTERISTICS			Standard Operating Conditions: 2.0V to 3.6V (unless otherwise stated) Operating temperature -40°C ≤ TA ≤ +85°C for Industrial -40°C ≤ TA ≤ +125°C for Extended				
Param No.	Sym	Characteristic	Min	Typ <sup>(1)</sup>	Max	Units	Conditions
	IOUT1	CTMU Current Source, Base Range	—	550	—	nA	CTMUICON<1:0> = 01
	IOUT2	CTMU Current Source, 10x Range	—	5.5	—	μA	CTMUICON<1:0> = 10
	IOUT3	CTMU Current Source, 100x Range	—	55	—	μA	CTMUICON<1:0> = 11

**Note 1:** Nominal value at the center point of the current trim range (CTMUICON<7:2> = 000000).

# PIC24F16KA102 FAMILY

## 29.2 AC Characteristics and Timing Parameters

The information contained in this section defines the PIC24F16KA102 family AC characteristics and timing parameters.

**TABLE 29-17: TEMPERATURE AND VOLTAGE SPECIFICATIONS – AC**

<b>AC CHARACTERISTICS</b>	<b>Standard Operating Conditions: 1.8V to 3.6V (unless otherwise stated)</b>
	Operating temperature $-40^{\circ}\text{C} \leq T_A \leq +85^{\circ}\text{C}$ for Industrial
	$-40^{\circ}\text{C} \leq T_A \leq +125^{\circ}\text{C}$ for Extended
	Operating voltage $V_{DD}$ range as described in <a href="#">Section 29.1 “DC Characteristics”</a> .

**FIGURE 29-4: LOAD CONDITIONS FOR DEVICE TIMING SPECIFICATIONS**

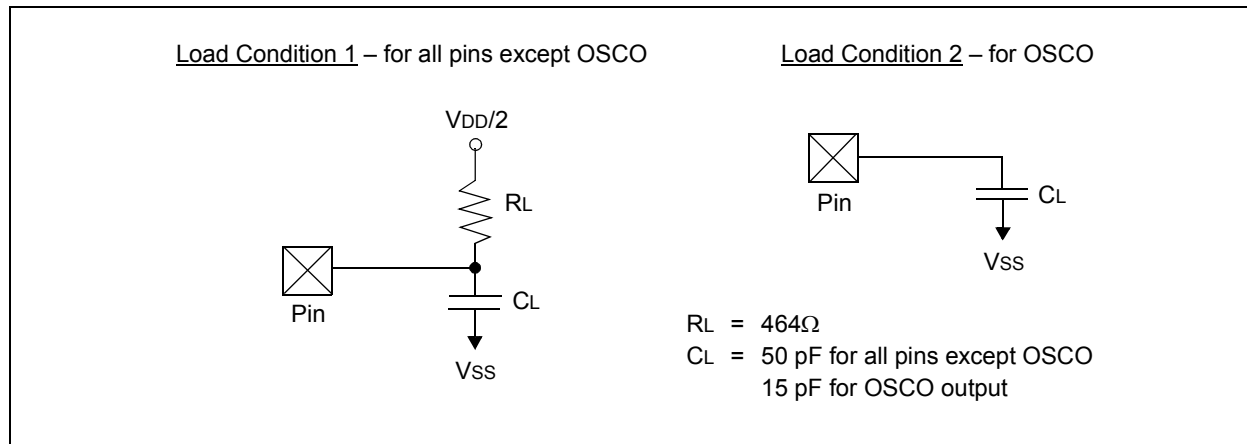

**TABLE 29-18: CAPACITIVE LOADING REQUIREMENTS ON OUTPUT PINS**

Param No.	Symbol	Characteristic	Min	Typ <sup>(1)</sup>	Max	Units	Conditions
DO50	Cosc2	OSCO/CLKO pin	—	—	15	pF	In XT and HS modes when external clock is used to drive OSC1
DO56	Cio	All I/O Pins and OSCO	—	—	50	pF	EC mode
DO58	CB	SCLx, SDAx	—	—	400	pF	In I <sup>2</sup> C™ mode

**Note 1:** Data in “Typ” column is at 3.3V, 25°C unless otherwise stated. Parameters are for design guidance only and are not tested.

# PIC24F16KA102 FAMILY

**FIGURE 29-5: EXTERNAL CLOCK TIMING**



**TABLE 29-19: EXTERNAL CLOCK TIMING REQUIREMENTS**

AC CHARACTERISTICS			Standard Operating Conditions: 1.8 to 3.6V (unless otherwise stated) Operating temperature $-40^{\circ}\text{C} \leq T_A \leq +85^{\circ}\text{C}$ for Industrial $-40^{\circ}\text{C} \leq T_A \leq +125^{\circ}\text{C}$ for Extended				
Param No.	Sym	Characteristic	Min	Typ <sup>(1)</sup>	Max	Units	Conditions
OS10	Fosc	External CLKI Frequency (External clocks allowed only in EC mode) <sup>(2)</sup>	DC 4	— —	32 8	MHz MHz	EC ECPLL
		Oscillator Frequency <sup>(2)</sup>	0.2 4 4 31	— — — —	4 25 8 33	MHz MHz MHz kHz	XT HS HSPLL SOSC
OS20	Tosc	Tosc = 1/Fosc	—	—	—	—	See Parameter OS10 for Fosc value
OS25	Tcy	Instruction Cycle Time <sup>(3)</sup>	62.5	—	DC	ns	
OS30	TosL, TosH	External Clock in (OSCI) High or Low Time	0.45 x Tosc	—	—	ns	EC
OS40	TckR	CLKO Rise Time <sup>(4)</sup>	—	6	10	ns	
OS41	TckF	CLKO Fall Time <sup>(4)</sup>	—	6	10	ns	

**Note 1:** Data in “Typ” column is at 3.3V, 25°C unless otherwise stated. Parameters are for design guidance only and are not tested.

**2:** Refer to [Figure 29-1](#) for the minimum voltage at a given frequency.

**3:** Instruction cycle period (Tcy) equals two times the input oscillator time base period. All specified values are based on characterization data for that particular oscillator type under standard operating conditions with the device executing code. Exceeding these specified limits may result in an unstable oscillator operation and/or higher than expected current consumption. All devices are tested to operate at “Min.” values with an external clock applied to the OSCI/CLKI pin. When an external clock input is used, the “Max.” cycle time limit is “DC” (no clock) for all devices.

**4:** Measurements are taken in EC mode. The CLKO signal is measured on the OSCO pin. CLKO is low for the Q1-Q2 period (1/2 Tcy) and high for the Q3-Q4 period (1/2 Tcy).



# PIC24F16KA102 FAMILY

**TABLE 29-20: PLL CLOCK TIMING SPECIFICATIONS (V<sub>DD</sub> = 1.8V TO 3.6V)**

AC CHARACTERISTICS			Standard Operating Conditions: 1.8V to 3.6V (unless otherwise stated) Operating temperature -40°C ≤ TA ≤ +85°C for Industrial -40°C ≤ TA ≤ +125°C for Extended				
Param No.	Sym	Characteristic <sup>(1)</sup>	Min	Typ <sup>(2)</sup>	Max	Units	Conditions
OS50	FPLLI	PLL Input Frequency Range	4	—	8	MHz	ECPLL, HSPLL modes, -40°C ≤ TA ≤ +85°C
OS51	FSYS	PLL Output Frequency Range	16	—	32	MHz	-40°C ≤ TA ≤ +85°C
OS52	TLOCK	PLL Start-up Time (Lock Time)	—	1	2	ms	
OS53	DCLK	CLKO Stability (Jitter)	-2	1	2	%	Measured over a 100 ms period

**Note 1:** These parameters are characterized but not tested in manufacturing.

**2:** Data in “Typ” column is at 3.3V, 25°C unless otherwise stated. Parameters are for design guidance only and are not tested.

**TABLE 29-21: AC CHARACTERISTICS: INTERNAL RC ACCURACY**

AC CHARACTERISTICS		Standard Operating Conditions: 1.8V to 3.6V (unless otherwise stated) Operating temperature -40°C ≤ TA ≤ +85°C for Industrial -40°C ≤ TA ≤ +125°C for Extended				
Param No.	Characteristic	Min	Typ	Max	Units	Conditions
F20	<b>Internal FRC Accuracy @ 8 MHz<sup>(1)</sup></b>					
	FRC	-1	—	+1	%	+25°C
		-3	—	+3	%	-40°C ≤ TA ≤ +85°C
		-5	—	+5	%	-40°C ≤ TA ≤ +85°C
	-10	—	+10	%	-40°C ≤ TA ≤ +125°C	
F21	<b>LPRC @ 31 kHz<sup>(2)</sup></b>					
		-15	—	15	%	+25°C
		-15	—	15	%	-40°C ≤ TA ≤ +85°C
-30		—	+30	%	-40°C ≤ TA ≤ +125°C	

**Note 1:** Frequency calibrated at 25°C and 3.3V. OSCTUN bits can be used to compensate for temperature drift.

**2:** Change of LPRC frequency as V<sub>DD</sub> changes.

# PIC24F16KA102 FAMILY

**TABLE 29-22: AC SPECIFICATIONS**

Symbol	Characteristics	Min	Typ	Max	Units
TLW	BCLKx High Time	20	$T_{CY}/2$	—	ns
THW	BCLKx Low Time	20	$(T_{CY} * BRGx) + T_{CY}/2$	—	ns
TBLD	BCLKx Falling Edge Delay from UxTX	-50	—	50	ns
TBHD	BCLKx Rising Edge Delay from UxTX	$T_{CY}/2 - 50$	—	$T_{CY}/2 + 50$	ns
TWAK	Min. Low on UxRX Line to Cause Wake-up	—	1	—	$\mu$ s
TCTS	Min. Low on $\overline{UxCTS}$ Line to Start Transmission	$T_{CY}$	—	—	ns
TSETUP	Start bit Falling Edge to System Clock Rising Edge Setup Time	3	—	—	ns
TSTDELAY	Maximum Delay in the Detection of the Start bit Falling Edge	—	—	$T_{CY} + TSETUP$	ns

**TABLE 29-23: A/D CONVERSION TIMING REQUIREMENTS<sup>(1)</sup>**

A/D CHARACTERISTICS		Standard Operating Conditions: 1.8V to 3.6V (unless otherwise stated) Operating temperature $-40^{\circ}\text{C} \leq T_A \leq +85^{\circ}\text{C}$ for Industrial $-40^{\circ}\text{C} \leq T_A \leq +125^{\circ}\text{C}$ for Extended					
Param No.	Symbol	Characteristic	Min.	Typ	Max.	Units	Conditions
<b>Clock Parameters</b>							
AD50	TAD	A/D Clock Period	75	—	—	ns	$T_{CY} = 75$ ns, AD1CON3 is in the default state
AD51	TRC	A/D Internal RC Oscillator Period	—	250	—	ns	
<b>Conversion Rate</b>							
AD55	TCONV	Conversion Time	—	12	—	TAD	
AD56	FCNV	Throughput Rate	—	—	500	ksps	$AV_{DD} \geq 2.7\text{V}$
AD57	TSAMP	Sample Time	—	1	—	TAD	
AD58	TACQ	Acquisition Time	750	—	—	ns	<b>(Note 2)</b>
AD59	TSWC	Switching Time from Convert to Sample	—	—	<b>(Note 3)</b>		
AD60	TDIS	Discharge Time	0.5	—	—	TAD	
<b>Clock Parameters</b>							
AD61	TPSS	Sample Start Delay from Setting Sample bit (SAMP)	2	—	3	TAD	

**Note 1:** Because the sample caps will eventually lose charge, clock rates below 10 kHz can affect linearity performance, especially at elevated temperatures.

**2:** The time for the holding capacitor to acquire the “New” input voltage when the voltage changes full scale after the conversion ( $V_{DD}$  to  $V_{SS}$  or  $V_{SS}$  to  $V_{DD}$ ).

**3:** On the following cycle of the device clock.

# PIC24F16KA102 FAMILY

**TABLE 29-24: A/D MODULE SPECIFICATIONS**

A/D CHARACTERISTICS			Standard Operating Conditions: 1.8V to 3.6V (unless otherwise stated) Operating temperature $-40^{\circ}\text{C} \leq T_A \leq +85^{\circ}\text{C}$ for Industrial $-40^{\circ}\text{C} \leq T_A \leq +125^{\circ}\text{C}$ for Extended				
Param No.	Symbol	Characteristic	Min.	Typ	Max.	Units	Conditions
<b>Device Supply</b>							
AD01	AVDD	Module VDD Supply	Greater of VDD – 0.3 or 1.8	—	Lesser of VDD + 0.3 or 3.6	V	
AD02	AVSS	Module Vss Supply	Vss – 0.3	—	Vss + 0.3	V	
<b>Reference Inputs</b>							
AD05	VREFH	Reference Voltage High	AVSS + 1.7	—	AVDD	V	
AD06	VREFL	Reference Voltage Low	AVSS	—	AVDD – 1.7	V	
AD07	VREF	Absolute Reference Voltage	AVSS – 0.3	—	AVDD + 0.3	V	
AD08	IVREF	Reference Voltage Input Current	—	—	200	$\mu\text{A}$	VREF+ = 3.3V; sampling
			—	—	1.0	mA	VREF+ = 3.3V; converting
AD09	ZVREF	Reference Input Impedance	—	10K	—	$\Omega$	(Note 3)
<b>Analog Input</b>							
AD10	VINH-VINL	Full-Scale Input Span	VREFL	—	VREFH	V	(Note 2)
AD11	VIN	Absolute Input Voltage	AVSS – 0.3	—	AVDD + 0.3	V	
AD12	VINL	Absolute VINL Input Voltage	AVSS – 0.3	—	AVDD/2	V	
AD17	RIN	Recommended Impedance of Analog Voltage Source	—	—	2.5K	$\Omega$	10-bit
<b>A/D Accuracy</b>							
AD20b	NR	Resolution	—	10	—	bits	
AD21b	INL	Integral Nonlinearity	—	$\pm 1$	$\pm 2$	LSb	VINL = AVSS = VREFL = 0V, AVDD = VREFH = 3V
AD22b	DNL	Differential Nonlinearity	—	$\pm 1$	-1 +1.5	LSb	VINL = AVSS = VREFL = 0V, AVDD = VREFH = 3V
AD23b	GERR	Gain Error	—	$\pm 1$	$\pm 3$	LSb	VINL = AVSS = VREFL = 0V, AVDD = VREFH = 3V
AD24b	EOFF	Offset Error	—	$\pm 1$	$\pm 2$	LSb	VINL = AVSS = VREFL = 0V, AVDD = VREFH = 3V
AD25b		Monotonicity	—	—	—	—	(Note 1)

- Note 1:** The A/D conversion result never decreases with an increase in the input voltage and has no missing codes.
- 2:** Measurements are taken with external VREF+ and VREF- used as the A/D voltage reference.
- 3:** Impedance during sampling is at 3.3V, 25°C. This parameter is for design guidance only and is not tested.

# PIC24F16KA102 FAMILY

**FIGURE 29-6: CLKO AND I/O TIMING CHARACTERISTICS**

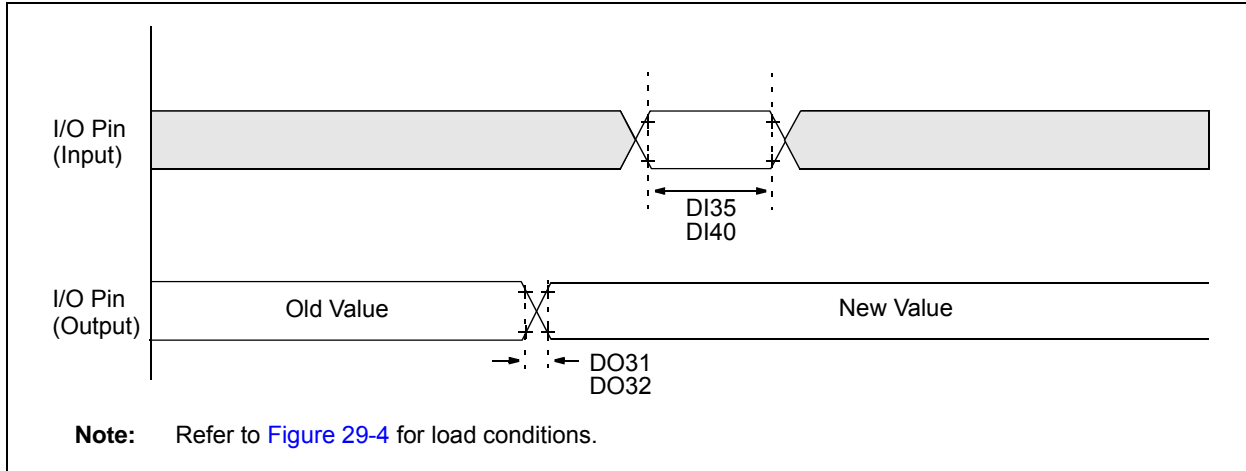

**TABLE 29-25: CLKO AND I/O TIMING REQUIREMENTS**

AC CHARACTERISTICS			Standard Operating Conditions: 1.8V to 3.6V (unless otherwise stated)				
			Operating temperature $-40^{\circ}\text{C} \leq T_A \leq +85^{\circ}\text{C}$ for Industrial $-40^{\circ}\text{C} \leq T_A \leq +125^{\circ}\text{C}$ for Extended				
Param No.	Sym	Characteristic	Min	Typ <sup>(1)</sup>	Max	Units	Conditions
DO31	TioR	Port Output Rise Time	—	10	25	ns	
DO32	TioF	Port Output Fall Time	—	10	25	ns	
DI35	TINP	INTx pin High or Low Time (output)	20	—	—	ns	
DI40	TRBP	CNx High or Low Time (input)	2	—	—	Tcy	

**Note 1:** Data in "Typ" column is at 3.3V, 25°C unless otherwise stated.

# PIC24F16KA102 FAMILY

**TABLE 29-26: COMPARATOR TIMINGS**

Param No.	Symbol	Characteristic	Min	Typ	Max	Units	Comments
300	TRESP	Response Time <sup>*(1)</sup>	—	150	400	ns	
301	TMC2OV	Comparator Mode Change to Output Valid*	—	—	10	μs	

\* Parameters are characterized but not tested.

**Note 1:** Response time is measured with one comparator input at  $(V_{DD} - 1.5)/2$ , while the other input transitions from  $V_{SS}$  to  $V_{DD}$ .

**TABLE 29-27: COMPARATOR VOLTAGE REFERENCE SETTLING TIME SPECIFICATIONS**

Param No.	Symbol	Characteristic	Min	Typ	Max	Units	Comments
VR310	TSET	Settling Time <sup>(1)</sup>	—	—	10	μs	

**Note 1:** Settling time is measured while  $CVRR = 1$  and  $CVR<3:0>$  bits transition from '0000' to '1111'.

# PIC24F16KA102 FAMILY

**FIGURE 29-7: RESET, WATCHDOG TIMER, OSCILLATOR START-UP TIMER AND POWER-UP TIMER TIMING CHARACTERISTICS**



# PIC24F16KA102 FAMILY

**TABLE 29-28: RESET, WATCHDOG TIMER, OSCILLATOR START-UP TIMER, POWER-UP TIMER AND BROWN-OUT RESET TIMING REQUIREMENTS**

AC CHARACTERISTICS			Standard Operating Conditions: 1.8V to 3.6V (unless otherwise stated) Operating temperature $-40^{\circ}\text{C} \leq T_A \leq +85^{\circ}\text{C}$ for Industrial $-40^{\circ}\text{C} \leq T_A \leq +125^{\circ}\text{C}$ for Extended				
Param No.	Symbol	Characteristic	Min.	Typ <sup>(1)</sup>	Max.	Units	Conditions
SY10	TmCL	$\overline{\text{MCLR}}$ Pulse Width (low)	2	—	—	$\mu\text{s}$	
SY11	TPWRT	Power-up Timer Period	50	64	90	ms	
SY12	TPOR	Power-on Reset Delay	1	5	10	$\mu\text{s}$	
SY13	TIOZ	I/O High-Impedance from $\overline{\text{MCLR}}$ Low or Watchdog Timer Reset	—	—	100	ns	
SY20	TWDT	Watchdog Timer Time-out Period	0.85	1.0	1.15	ms	1.32 prescaler
			3.4	4.0	4.6	ms	1:128 prescaler
SY25	TBOR	Brown-out Reset Pulse Width	1	—	—	$\mu\text{s}$	
SY35	TFSCM	Fail-Safe Clock Monitor Delay	—	2	2.3	$\mu\text{s}$	
SY45	TRST	Configuration Update Time	—	20	—	$\mu\text{s}$	
SY55	TLOCK	PLL Start-up Time	—	1	—	ms	
SY65	TOST	Oscillator Start-up Time	—	1024	—	TOSC	
SY75	TFRC	Fast RC Oscillator Start-up Time	—	1	1.5	$\mu\text{s}$	
SY85	TLPRC	Low-Power Oscillator Start-up Time	—	—	100	$\mu\text{s}$	

**Note 1:** Data in “Typ” column is at 3.3V, 25°C unless otherwise stated.

**FIGURE 29-8: BAUD RATE GENERATOR OUTPUT TIMING**



# PIC24F16KA102 FAMILY

**FIGURE 29-9: I<sup>2</sup>C™ BUS START/STOP BITS TIMING CHARACTERISTICS (MASTER MODE)**



**TABLE 29-29: I<sup>2</sup>C™ BUS START/STOP BIT TIMING REQUIREMENTS (MASTER MODE)**

AC CHARACTERISTICS			Standard Operating Conditions: 2.0V to 3.6V (unless otherwise stated) Operating temperature -40°C ≤ T <sub>A</sub> ≤ +85°C for Industrial) -40°C ≤ T <sub>A</sub> ≤ +125°C for Extended				
Param No.	Symbol	Characteristic	Min <sup>(1)</sup>	Max	Units	Conditions	
IM30	TSU:STA	Start Condition Setup Time	100 kHz mode	T <sub>CY</sub> /2 (BRG + 1)	—	μs	Only relevant for Repeated Start condition
			400 kHz mode	T <sub>CY</sub> /2 (BRG + 1)	—	μs	
			1 MHz mode <sup>(2)</sup>	T <sub>CY</sub> /2 (BRG + 1)	—	μs	
IM31	THD:STA	Start Condition Hold Time	100 kHz mode	T <sub>CY</sub> /2 (BRG + 1)	—	μs	After this period, the first clock pulse is generated
			400 kHz mode	T <sub>CY</sub> /2 (BRG + 1)	—	μs	
			1 MHz mode <sup>(2)</sup>	T <sub>CY</sub> /2 (BRG + 1)	—	μs	
IM33	TSU:STO	Stop Condition Setup Time	100 kHz mode	T <sub>CY</sub> /2 (BRG + 1)	—	μs	
			400 kHz mode	T <sub>CY</sub> /2 (BRG + 1)	—	μs	
			1 MHz mode <sup>(2)</sup>	T <sub>CY</sub> /2 (BRG + 1)	—	μs	
IM34	THD:STO	Stop Condition Hold Time	100 kHz mode	T <sub>CY</sub> /2 (BRG + 1)	—	ns	
			400 kHz mode	T <sub>CY</sub> /2 (BRG + 1)	—	ns	
			1 MHz mode <sup>(2)</sup>	T <sub>CY</sub> /2 (BRG + 1)	—	ns	

**Note 1:** BRG is the value of the I<sup>2</sup>C™ Baud Rate Generator. Refer to Section 17.3 “Setting Baud Rate When Operating as a Bus Master” for details.

**Note 2:** Maximum pin capacitance = 10 pF for all I<sup>2</sup>C pins (for 1 MHz mode only).

**FIGURE 29-10: I<sup>2</sup>C™ BUS DATA TIMING CHARACTERISTICS (MASTER MODE)**





# PIC24F16KA102 FAMILY

**TABLE 29-30: I<sup>2</sup>C™ BUS DATA TIMING REQUIREMENTS (MASTER MODE)**

AC CHARACTERISTICS				Standard Operating Conditions: 2.0V to 3.6V (unless otherwise stated) Operating temperature -40°C ≤ TA ≤ +85°C for Industrial -40°C ≤ TA ≤ +125°C for Extended			
Param No.	Symbol	Characteristic		Min <sup>(1)</sup>	Max	Units	Conditions
IM10	TLO:SCL	Clock Low Time	100 kHz mode	T <sub>CY</sub> /2 (BRG + 1)	—	μs	
			400 kHz mode	T <sub>CY</sub> /2 (BRG + 1)	—	μs	
			1 MHz mode <sup>(2)</sup>	T <sub>CY</sub> /2 (BRG + 1)	—	μs	
IM11	THI:SCL	Clock High Time	100 kHz mode	T <sub>CY</sub> /2 (BRG + 1)	—	μs	
			400 kHz mode	T <sub>CY</sub> /2 (BRG + 1)	—	μs	
			1 MHz mode <sup>(2)</sup>	T <sub>CY</sub> /2 (BRG + 1)	—	μs	
IM20	TF:SCL	SDAx and SCLx Fall Time	100 kHz mode	—	300	ns	Cb is specified to be from 10 to 400 pF
			400 kHz mode	20 + 0.1 Cb	300	ns	
			1 MHz mode <sup>(2)</sup>	—	100	ns	
IM21	TR:SCL	SDAx and SCLx Rise Time	100 kHz mode	—	1000	ns	Cb is specified to be from 10 to 400 pF
			400 kHz mode	20 + 0.1 Cb	300	ns	
			1 MHz mode <sup>(2)</sup>	—	300	ns	
IM25	TSU:DAT	Data Input Setup Time	100 kHz mode	250	—	ns	
			400 kHz mode	100	—	ns	
			1 MHz mode <sup>(2)</sup>	TBD	—	ns	
IM26	THD:DAT	Data Input Hold Time	100 kHz mode	0	—	ns	
			400 kHz mode	0	0.9	μs	
			1 MHz mode <sup>(2)</sup>	TBD	—	ns	
IM40	TAA:SCL	Output Valid From Clock	100 kHz mode	—	3500	ns	
			400 kHz mode	—	1000	ns	
			1 MHz mode <sup>(2)</sup>	—	—	ns	
IM45	TBF:SDA	Bus Free Time	100 kHz mode	4.7	—	μs	Time the bus must be free before a new transmission can start
			400 kHz mode	1.3	—	μs	
			1 MHz mode <sup>(2)</sup>	TBD	—	μs	
IM50	CB	Bus Capacitive Loading		—	400	pF	

**Legend:** TBD = To Be Determined

**Note 1:** BRG is the value of the I<sup>2</sup>C Baud Rate Generator. Refer to [Section 17.3 “Setting Baud Rate When Operating as a Bus Master”](#) for details.

**2:** Maximum pin capacitance = 10 pF for all I<sup>2</sup>C pins (for 1 MHz mode only).

# PIC24F16KA102 FAMILY

**FIGURE 29-11: I<sup>2</sup>C™ BUS START/STOP BITS TIMING CHARACTERISTICS (SLAVE MODE)**



**FIGURE 29-12: I<sup>2</sup>C™ BUS DATA TIMING CHARACTERISTICS (SLAVE MODE)**



**TABLE 29-31: I<sup>2</sup>C™ BUS START/STOP BIT TIMING REQUIREMENTS (SLAVE MODE)**

AC CHARACTERISTICS				Standard Operating Conditions: 2.0V to 3.6V (unless otherwise stated) Operating temperature -40°C ≤ T <sub>A</sub> ≤ +85°C (Industrial) -40°C ≤ T <sub>A</sub> ≤ +125°C for Extended			
Param No.	Symbol	Characteristic	Min	Max	Units	Conditions	
IS30	TSU:STA	Start Condition Setup Time	100 kHz mode	4.7	—	μs	Only relevant for Repeated Start condition
			400 kHz mode	0.6	—	μs	
			1 MHz mode <sup>(1)</sup>	0.25	—	μs	
IS31	THD:STA	Start Condition Hold Time	100 kHz mode	4.0	—	μs	After this period, the first clock pulse is generated
			400 kHz mode	0.6	—	μs	
			1 MHz mode <sup>(1)</sup>	0.25	—	μs	
IS33	TSU:STO	Stop Condition Setup Time	100 kHz mode	4.7	—	μs	
			400 kHz mode	0.6	—	μs	
			1 MHz mode <sup>(1)</sup>	0.6	—	μs	
IS34	THD:STO	Stop Condition Hold Time	100 kHz mode	4000	—	ns	
			400 kHz mode	600	—	ns	
			1 MHz mode <sup>(1)</sup>	250	—	ns	

**Note 1:** Maximum pin capacitance = 10 pF for all I<sup>2</sup>C™ pins (for 1 MHz mode only).

# PIC24F16KA102 FAMILY

**TABLE 29-32: I<sup>2</sup>C™ BUS DATA TIMING REQUIREMENTS (SLAVE MODE)**

AC CHARACTERISTICS				Standard Operating Conditions: 2.0V to 3.6V (unless otherwise stated) Operating temperature -40°C ≤ TA ≤ +85°C (Industrial) -40°C ≤ TA ≤ +125°C for Extended			
Param No.	Symbol	Characteristic		Min	Max	Units	Conditions
IS10	TLO:SCL	Clock Low Time	100 kHz mode	4.7	—	μs	Device must operate at a minimum of 1.5 MHz
			400 kHz mode	1.3	—	μs	
			1 MHz mode <sup>(1)</sup>	0.5	—	μs	
IS11	THI:SCL	Clock High Time	100 kHz mode	4.0	—	μs	Device must operate at a minimum of 1.5 MHz
			400 kHz mode	0.6	—	μs	
			1 MHz mode <sup>(1)</sup>	0.5	—	μs	
IS20	TF:SCL	SDAx and SCLx Fall Time	100 kHz mode	—	300	ns	CB is specified to be from 10 to 400 pF
			400 kHz mode	20 + 0.1 CB	300	ns	
			1 MHz mode <sup>(1)</sup>	—	100	ns	
IS21	TR:SCL	SDAx and SCLx Rise Time	100 kHz mode	—	1000	ns	CB is specified to be from 10 to 400 pF
			400 kHz mode	20 + 0.1 CB	300	ns	
			1 MHz mode <sup>(1)</sup>	—	300	ns	
IS25	TSU:DAT	Data Input Setup Time	100 kHz mode	250	—	ns	
			400 kHz mode	100	—	ns	
			1 MHz mode <sup>(1)</sup>	100	—	ns	
IS26	THD:DAT	Data Input Hold Time	100 kHz mode	0	—	ns	
			400 kHz mode	0	0.9	μs	
			1 MHz mode <sup>(1)</sup>	0	0.3	μs	
IS40	TAA:SCL	Output Valid From Clock	100 kHz mode	0	3500	ns	
			400 kHz mode	0	1000	ns	
			1 MHz mode <sup>(1)</sup>	0	350	ns	
IS45	TBF:SDA	Bus Free Time	100 kHz mode	4.7	—	μs	Time the bus must be free before a new transmission can start
			400 kHz mode	1.3	—	μs	
			1 MHz mode <sup>(1)</sup>	0.5	—	μs	
IS50	CB	Bus Capacitive Loading		—	400	pF	

**Note 1:** Maximum pin capacitance = 10 pF for all I<sup>2</sup>C™ pins (for 1 MHz mode only).

**FIGURE 29-13: START BIT EDGE DETECTION**



# PIC24F16KA102 FAMILY

**FIGURE 29-14: INPUT CAPTURE TIMINGS**



**TABLE 29-33: INPUT CAPTURE**

Param. No.	Symbol	Characteristic		Min	Max	Units	Conditions
IC10	TccL	ICx Input Low Time – Synchronous Timer	No Prescaler	$T_{CY} + 20$	—	ns	Must also meet Parameter <b>IC15</b>
			With Prescaler	20	—	ns	
IC11	TccH	ICx Input Low Time – Synchronous Timer	No Prescaler	$T_{CY} + 20$	—	ns	Must also meet Parameter <b>IC15</b>
			With Prescaler	20	—	ns	
IC15	TccP	ICx Input Period – Synchronous Timer		$\frac{2 * T_{CY} + 40}{N}$	—	ns	N = prescale value (1, 4, 16)

**TABLE 29-34: OUTPUT CAPTURE**

Param. No.	Symbol	Characteristic	Min	Max	Units	Conditions
OC11	TccR	OC1 Output Rise Time	—	10	ns	
			—	—	ns	
OC10	TccF	OC1 Output Fall Time	—	10	ns	
			—	—	ns	

**FIGURE 29-15: OUTPUT COMPARE TIMINGS**



# PIC24F16KA102 FAMILY

**FIGURE 29-16: PWM MODULE TIMING REQUIREMENTS**



**TABLE 29-35: PWM TIMING REQUIREMENTS**

Param. No.	Symbol	Characteristic	Min	Typ <sup>†</sup>	Max	Units	Conditions
OC15	TFD	Fault Input to PWM I/O Change	—	—	25	ns	V <sub>DD</sub> = 3.0V, -40°C to +125°C
OC20	TFH	Fault Input Pulse Width	50	—	—	ns	V <sub>DD</sub> = 3.0V, -40°C to +125°C

<sup>†</sup> Data in "Typ" column is at 5V, 25°C unless otherwise stated. These parameters are for design guidance only and are not tested.

# PIC24F16KA102 FAMILY

**FIGURE 29-17: SPIx MODULE MASTER MODE TIMING CHARACTERISTICS (CKE = 0)**



**TABLE 29-36: SPIx MASTER MODE TIMING REQUIREMENTS (CKE = 0)**

AC CHARACTERISTICS			Standard Operating Conditions: 2.0V to 3.6V (unless otherwise stated) Operating temperature $-40^{\circ}\text{C} \leq T_A \leq +125^{\circ}\text{C}$ for Extended				
Param No.	Symbol	Characteristic	Min	Typ <sup>(1)</sup>	Max	Units	Conditions
SP10	TscL	SCKx Output Low Time <sup>(2)</sup>	$T_{CY}/2$	—	—	ns	
SP11	TscH	SCKx Output High Time <sup>(2)</sup>	$T_{CY}/2$	—	—	ns	
SP20	TscF	SCKx Output Fall Time <sup>(3)</sup>	—	10	25	ns	
SP21	TscR	SCKx Output Rise Time <sup>(3)</sup>	—	10	25	ns	
SP30	TdoF	SDOx Data Output Fall Time <sup>(3)</sup>	—	10	25	ns	
SP31	TdoR	SDOx Data Output Rise Time <sup>(3)</sup>	—	10	25	ns	
SP35	Tsch2doV, TscL2doV	SDOx Data Output Valid after SCKx Edge	—	—	30	ns	
SP40	TdiV2sch, TdiV2scL	Setup Time of SDIx Data Input to SCKx Edge	20	—	—	ns	
SP41	Tsch2diL, TscL2diL	Hold Time of SDIx Data Input to SCKx Edge	20	—	—	ns	

**Note 1:** Data in "Typ" column is at 3.3V, 25°C unless otherwise stated. Parameters are for design guidance only and are not tested.

**2:** The minimum clock period for SCKx is 100 ns; therefore, the clock generated in Master mode must not violate this specification.

**3:** Assumes 50 pF load on all SPIx pins.

# PIC24F16KA102 FAMILY

**FIGURE 29-18: SPIx MODULE MASTER MODE TIMING CHARACTERISTICS (CKE = 1)**



**TABLE 29-37: SPIx MODULE MASTER MODE TIMING REQUIREMENTS (CKE = 1)**

AC CHARACTERISTICS			Standard Operating Conditions: 2.0V to 3.6V (unless otherwise stated) Operating temperature -40°C ≤ TA ≤ +85°C for Industrial -40°C ≤ TA ≤ +125°C for Extended				
Param No.	Symbol	Characteristic	Min	Typ <sup>(1)</sup>	Max	Units	Conditions
SP10	TscL	SCKx Output Low Time <sup>(2)</sup>	Tcy/2	—	—	ns	
SP11	Tsch	SCKx Output High Time <sup>(2)</sup>	Tcy/2	—	—	ns	
SP20	TscF	SCKx Output Fall Time <sup>(3)</sup>	—	10	25	ns	
SP21	TscR	SCKx Output Rise Time <sup>(3)</sup>	—	10	25	ns	
SP30	TdoF	SDOx Data Output Fall Time <sup>(3)</sup>	—	10	25	ns	
SP31	TdoR	SDOx Data Output Rise Time <sup>(3)</sup>	—	10	25	ns	
SP35	Tsch2doV, TscL2doV	SDOx Data Output Valid after SCKx Edge	—	—	30	ns	
SP36	TdoV2sc, TdoV2scL	SDOx Data Output Setup to First SCKx Edge	30	—	—	ns	
SP40	TdiV2sch, TdiV2scL	Setup Time of SDIx Data Input to SCKx Edge	20	—	—	ns	
SP41	Tsch2diL, TscL2diL	Hold Time of SDIx Data Input to SCKx Edge	20	—	—	ns	

**Note 1:** Data in “Typ” column is at 3.3V, 25°C unless otherwise stated. Parameters are for design guidance only and are not tested.

**2:** The minimum clock period for SCKx is 100 ns. Therefore, the clock generated in Master mode must not violate this specification.

**3:** Assumes 50 pF load on all SPIx pins.

# PIC24F16KA102 FAMILY

**FIGURE 29-19: SPIx MODULE SLAVE MODE TIMING CHARACTERISTICS (CKE = 0)**



**TABLE 29-38: SPIx MODULE SLAVE MODE TIMING REQUIREMENTS (CKE = 0)**

AC CHARACTERISTICS			Standard Operating Conditions: 2.0V to 3.6V (unless otherwise stated) Operating temperature $-40^{\circ}\text{C} \leq T_A \leq +85^{\circ}\text{C}$ for Industrial $-40^{\circ}\text{C} \leq T_A \leq +125^{\circ}\text{C}$ for Extended				
Param No.	Symbol	Characteristic	Min	Typ <sup>(1)</sup>	Max	Units	Conditions
SP70	TscL	SCKx Input Low Time	30	—	—	ns	
SP71	TscH	SCKx Input High Time	30	—	—	ns	
SP72	TscF	SCKx Input Fall Time <sup>(2)</sup>	—	10	25	ns	
SP73	TscR	SCKx Input Rise Time <sup>(2)</sup>	—	10	25	ns	
SP30	TdoF	SDOx Data Output Fall Time <sup>(2)</sup>	—	10	25	ns	
SP31	TdoR	SDOx Data Output Rise Time <sup>(2)</sup>	—	10	25	ns	
SP35	Tsch2doV, TscL2doV	SDOx Data Output Valid after SCKx Edge	—	—	30	ns	
SP40	TdiV2scH, TdiV2scL	Setup Time of SDIx Data Input to SCKx Edge	20	—	—	ns	
SP41	Tsch2diL, TscL2diL	Hold Time of SDIx Data Input to SCKx Edge	20	—	—	ns	
SP50	TssL2scH, TssL2scL	$\overline{\text{SSx}}$ to SCKx $\uparrow$ or SCKx Input	120	—	—	ns	
SP51	TssH2doZ	$\overline{\text{SSx}}$ $\uparrow$ to SDOx Output High-Impedance <sup>(3)</sup>	10	—	50	ns	
SP52	Tsch2ssH TscL2ssH	$\overline{\text{SSx}}$ after SCKx Edge	$1.5 T_{CY} + 40$	—	—	ns	

**Note 1:** Data in "Typ" column is at 3.3V, 25°C unless otherwise stated. Parameters are for design guidance only and are not tested.

**Note 2:** The minimum clock period for SCKx is 100 ns. Therefore, the clock generated in Master mode must not violate this specification.

**Note 3:** Assumes 50 pF load on all SPIx pins.



# PIC24F16KA102 FAMILY

**FIGURE 29-20: SPIx MODULE SLAVE MODE TIMING CHARACTERISTICS (CKE = 1)**



**TABLE 29-39: SPIx MODULE SLAVE MODE TIMING REQUIREMENTS (CKE = 1)**

AC CHARACTERISTICS		Standard Operating Conditions: 2.0V to 3.6V (unless otherwise stated) Operating temperature $-40^{\circ}\text{C} \leq T_A \leq +85^{\circ}\text{C}$ for Industrial $-40^{\circ}\text{C} \leq T_A \leq +125^{\circ}\text{C}$ for Extended					
Param No.	Symbol	Characteristic	Min	Typ <sup>(1)</sup>	Max	Units	Conditions
SP70	TscL	SCKx Input Low Time	30	—	—	ns	
SP71	Tsch	SCKx Input High Time	30	—	—	ns	
SP72	TscF	SCKx Input Fall Time <sup>(2)</sup>	—	10	25	ns	
SP73	TscR	SCKx Input Rise Time <sup>(2)</sup>	—	10	25	ns	
SP30	TdoF	SDOx Data Output Fall Time <sup>(2)</sup>	—	10	25	ns	
SP31	TdoR	SDOx Data Output Rise Time <sup>(2)</sup>	—	10	25	ns	
SP35	Tsch2doV, TscL2doV	SDOx Data Output Valid after SCKx Edge	—	—	30	ns	
SP40	TdiV2scH, TdiV2scL	Setup Time of SDIx Data Input to SCKx Edge	20	—	—	ns	
SP41	Tsch2diL, TscL2diL	Hold Time of SDIx Data Input to SCKx Edge	20	—	—	ns	
SP50	TssL2scH, TssL2scL	$\overline{\text{SSx}} \downarrow$ to SCKx $\downarrow$ or SCKx $\uparrow$ Input	120	—	—	ns	
SP51	TssH2doZ	$\overline{\text{SSx}} \uparrow$ to SDOx Output High-Impedance <sup>(3)</sup>	10	—	50	ns	
SP52	Tsch2ssH, TscL2ssH	$\overline{\text{SSx}} \uparrow$ after SCKx Edge	$1.5 T_{CY} + 40$	—	—	ns	
SP60	TssL2doV	SDOx Data Output Valid after $\overline{\text{SSx}}$ Edge	—	—	50	ns	

**Note 1:** Data in "Typ" column is at 3.3V, 25°C unless otherwise stated. Parameters are for design guidance only and are not tested.

**Note 2:** The minimum clock period for SCKx is 100 ns. Therefore, the clock generated in Master mode must not violate this specification.

**Note 3:** Assumes 50 pF load on all SPIx pins.

# PIC24F16KA102 FAMILY

---

NOTES:

# PIC24F16KA102 FAMILY

## 30.0 PACKAGING INFORMATION

### 30.1 Package Marking Information

20-Lead PDIP



Example

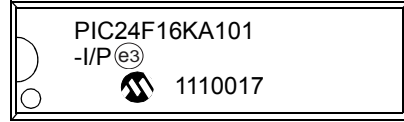

28-Lead SPDIP



Example

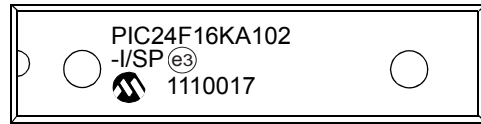

20-Lead SSOP



Example



28-Lead SSOP



Example



**Legend:** XX...X Product-specific information  
 Y Year code (last digit of calendar year)  
 YY Year code (last 2 digits of calendar year)  
 WW Week code (week of January 1 is week '01')  
 NNN Alphanumeric traceability code  
 (e3) Pb-free JEDEC designator for Matte Tin (Sn)  
 \* This package is Pb-free. The Pb-free JEDEC designator (e3) can be found on the outer packaging for this package.

**Note:** In the event the full Microchip part number cannot be marked on one line, it will be carried over to the next line, thus limiting the number of available characters for customer-specific information.

# PIC24F16KA102 FAMILY

---

20-Lead SOIC (.300")



Example



28-Lead SOIC (.300")



Example



20-Lead QFN



Example



28-Lead QFN



Example

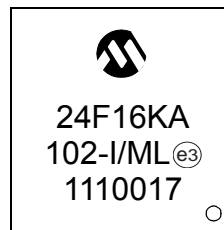

# PIC24F16KA102 FAMILY

## 30.2 Package Details

The following sections give the technical details of the packages.

### 20-Lead Plastic Dual In-Line (P) – 300 mil Body [PDIP]

**Note:** For the most current package drawings, please see the Microchip Packaging Specification located at <http://www.microchip.com/packaging>



		Units	INCHES		
Dimension Limits			MIN	NOM	MAX
Number of Pins	N		20		
Pitch	e		.100 BSC		
Top to Seating Plane	A	–	–		.210
Molded Package Thickness	A2	.115	.130		.195
Base to Seating Plane	A1	.015	–		–
Shoulder to Shoulder Width	E	.300	.310		.325
Molded Package Width	E1	.240	.250		.280
Overall Length	D	.980	1.030		1.060
Tip to Seating Plane	L	.115	.130		.150
Lead Thickness	c	.008	.010		.015
Upper Lead Width	b1	.045	.060		.070
Lower Lead Width	b	.014	.018		.022
Overall Row Spacing §	eB	–	–		.430

**Notes:**

1. Pin 1 visual index feature may vary, but must be located within the hatched area.
2. § Significant Characteristic.
3. Dimensions D and E1 do not include mold flash or protrusions. Mold flash or protrusions shall not exceed .010" per side.
4. Dimensioning and tolerancing per ASME Y14.5M.

BSC: Basic Dimension. Theoretically exact value shown without tolerances.

Microchip Technology Drawing C04-019B

# PIC24F16KA102 FAMILY

## 28-Lead Skinny Plastic Dual In-Line (SP) – 300 mil Body [SPDIP]

**Note:** For the most current package drawings, please see the Microchip Packaging Specification located at <http://www.microchip.com/packaging>

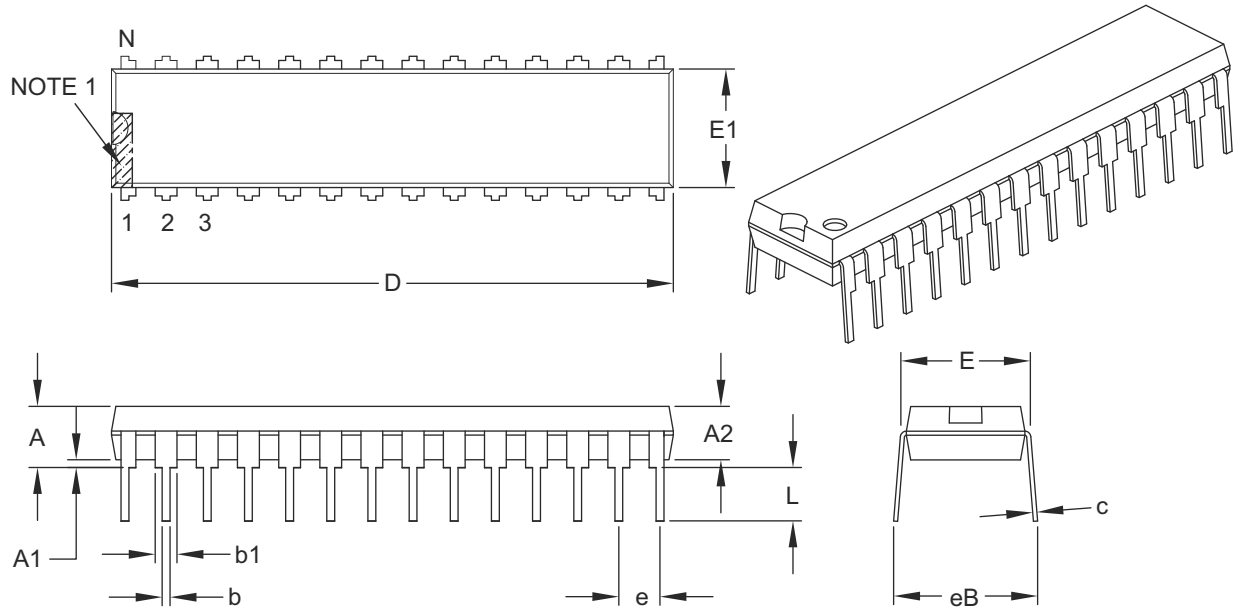

		Units	INCHES		
Dimension Limits			MIN	NOM	MAX
Number of Pins	N		28		
Pitch	e		.100 BSC		
Top to Seating Plane	A	–	–		.200
Molded Package Thickness	A2	.120	.135		.150
Base to Seating Plane	A1	.015	–		–
Shoulder to Shoulder Width	E	.290	.310		.335
Molded Package Width	E1	.240	.285		.295
Overall Length	D	1.345	1.365		1.400
Tip to Seating Plane	L	.110	.130		.150
Lead Thickness	c	.008	.010		.015
Upper Lead Width	b1	.040	.050		.070
Lower Lead Width	b	.014	.018		.022
Overall Row Spacing §	eB	–	–		.430

**Notes:**

- Pin 1 visual index feature may vary, but must be located within the hatched area.
- § Significant Characteristic.
- Dimensions D and E1 do not include mold flash or protrusions. Mold flash or protrusions shall not exceed .010" per side.
- Dimensioning and tolerancing per ASME Y14.5M.

BSC: Basic Dimension. Theoretically exact value shown without tolerances.

Microchip Technology Drawing C04-070B

# PIC24F16KA102 FAMILY

## 20-Lead Plastic Shrink Small Outline (SS) – 5.30 mm Body [SSOP]

**Note:** For the most current package drawings, please see the Microchip Packaging Specification located at <http://www.microchip.com/packaging>



Dimension Limits	Units	MILLIMETERS		
		MIN	NOM	MAX
Number of Pins	N	20		
Pitch	e	0.65 BSC		
Overall Height	A	–	–	2.00
Molded Package Thickness	A2	1.65	1.75	1.85
Standoff	A1	0.05	–	–
Overall Width	E	7.40	7.80	8.20
Molded Package Width	E1	5.00	5.30	5.60
Overall Length	D	6.90	7.20	7.50
Foot Length	L	0.55	0.75	0.95
Footprint	L1	1.25 REF		
Lead Thickness	c	0.09	–	0.25
Foot Angle	$\phi$	0°	4°	8°
Lead Width	b	0.22	–	0.38

**Notes:**

- Pin 1 visual index feature may vary, but must be located within the hatched area.
- Dimensions D and E1 do not include mold flash or protrusions. Mold flash or protrusions shall not exceed 0.20 mm per side.
- Dimensioning and tolerancing per ASME Y14.5M.

BSC: Basic Dimension. Theoretically exact value shown without tolerances.

REF: Reference Dimension, usually without tolerance, for information purposes only.

Microchip Technology Drawing C04-072B

# PIC24F16KA102 FAMILY

20-Lead Plastic Shrink Small Outline (SS) - 5.30 mm Body [SSOP]

**Note:** For the most current package drawings, please see the Microchip Packaging Specification located at <http://www.microchip.com/packaging>



RECOMMENDED LAND PATTERN

Dimension Limits	Units	MILLIMETERS		
		MIN	NOM	MAX
Contact Pitch	E	0.65 BSC		
Contact Pad Spacing	C		7.20	
Contact Pad Width (X20)	X1			0.45
Contact Pad Length (X20)	Y1			1.75
Distance Between Pads	G	0.20		

Notes:

1. Dimensioning and tolerancing per ASME Y14.5M

BSC: Basic Dimension. Theoretically exact value shown without tolerances.

Microchip Technology Drawing No. C04-2072A



# PIC24F16KA102 FAMILY

## 28-Lead Plastic Shrink Small Outline (SS) – 5.30 mm Body [SSOP]

**Note:** For the most current package drawings, please see the Microchip Packaging Specification located at <http://www.microchip.com/packaging>



Dimension Limits	Units	MILLIMETERS		
		MIN	NOM	MAX
Number of Pins	N	28		
Pitch	e	0.65 BSC		
Overall Height	A	–	–	2.00
Molded Package Thickness	A2	1.65	1.75	1.85
Standoff	A1	0.05	–	–
Overall Width	E	7.40	7.80	8.20
Molded Package Width	E1	5.00	5.30	5.60
Overall Length	D	9.90	10.20	10.50
Foot Length	L	0.55	0.75	0.95
Footprint	L1	1.25 REF		
Lead Thickness	c	0.09	–	0.25
Foot Angle	$\phi$	0°	4°	8°
Lead Width	b	0.22	–	0.38

**Notes:**

- Pin 1 visual index feature may vary, but must be located within the hatched area.
- Dimensions D and E1 do not include mold flash or protrusions. Mold flash or protrusions shall not exceed 0.20 mm per side.
- Dimensioning and tolerancing per ASME Y14.5M.

BSC: Basic Dimension. Theoretically exact value shown without tolerances.

REF: Reference Dimension, usually without tolerance, for information purposes only.

Microchip Technology Drawing C04-073B

# PIC24F16KA102 FAMILY

28-Lead Plastic Shrink Small Outline (SS) - 5.30 mm Body [SSOP]

**Note:** For the most current package drawings, please see the Microchip Packaging Specification located at <http://www.microchip.com/packaging>



Dimension Limits	Units	MILLIMETERS		
		MIN	NOM	MAX
Contact Pitch	E	0.65 BSC		
Contact Pad Spacing	C		7.20	
Contact Pad Width (X28)	X1			0.45
Contact Pad Length (X28)	Y1			1.75
Distance Between Pads	G	0.20		

Notes:

1. Dimensioning and tolerancing per ASME Y14.5M

BSC: Basic Dimension. Theoretically exact value shown without tolerances.

Microchip Technology Drawing No. C04-2073A

# PIC24F16KA102 FAMILY

## 20-Lead Plastic Small Outline (SO) - Wide, 7.50 mm Body [SOIC]

**Note:** For the most current package drawings, please see the Microchip Packaging Specification located at <http://www.microchip.com/packaging>



Microchip Technology Drawing C04-094C Sheet 1 of 2

# PIC24F16KA102 FAMILY

## 20-Lead Plastic Small Outline (SO) - Wide, 7.50 mm Body [SOIC]

**Note:** For the most current package drawings, please see the Microchip Packaging Specification located at <http://www.microchip.com/packaging>



Dimension Limits	Units	MILLIMETERS		
		MIN	NOM	MAX
Number of Pins	N	20		
Pitch	e	1.27 BSC		
Overall Height	A	-	-	2.65
Molded Package Thickness	A2	2.05	-	-
Standoff §	A1	0.10	-	0.30
Overall Width	E	10.30 BSC		
Molded Package Width	E1	7.50 BSC		
Overall Length	D	12.80 BSC		
Chamfer (Optional)	h	0.25	-	0.75
Foot Length	L	0.40	-	1.27
Footprint	L1	1.40 REF		
Lead Angle	Θ	0°	-	-
Foot Angle	φ	0°	-	8°
Lead Thickness	c	0.20	-	0.33
Lead Width	b	0.31	-	0.51
Mold Draft Angle Top	α	5°	-	15°
Mold Draft Angle Bottom	β	5°	-	15°

### Notes:

- Pin 1 visual index feature may vary, but must be located within the hatched area.
- § Significant Characteristic
- Dimension D does not include mold flash, protrusions or gate burrs, which shall not exceed 0.15 mm per end. Dimension E1 does not include interlead flash or protrusion, which shall not exceed 0.25 mm per side.
- Dimensioning and tolerancing per ASME Y14.5M  
 BSC: Basic Dimension. Theoretically exact value shown without tolerances.  
 REF: Reference Dimension, usually without tolerance, for information purposes only.
- Datums A & B to be determined at Datum H.

Microchip Technology Drawing No. C04-094C Sheet 2 of 2

# PIC24F16KA102 FAMILY

20-Lead Plastic Small Outline (SO) - Wide, 7.50 mm Body [SOIC]

**Note:** For the most current package drawings, please see the Microchip Packaging Specification located at <http://www.microchip.com/packaging>



RECOMMENDED LAND PATTERN

Dimension Limits	Units	MILLIMETERS		
		MIN	NOM	MAX
Contact Pitch	E	1.27 BSC		
Contact Pad Spacing	C		9.40	
Contact Pad Width (X20)	X			0.60
Contact Pad Length (X20)	Y			1.95
Distance Between Pads	Gx	0.67		
Distance Between Pads	G	7.45		

**Notes:**

1. Dimensioning and tolerancing per ASME Y14.5M

BSC: Basic Dimension. Theoretically exact value shown without tolerances.

Microchip Technology Drawing No. C04-2094A



# PIC24F16KA102 FAMILY

## 28-Lead Plastic Small Outline (SO) - Wide, 7.50 mm Body [SOIC]

**Note:** For the most current package drawings, please see the Microchip Packaging Specification located at <http://www.microchip.com/packaging>

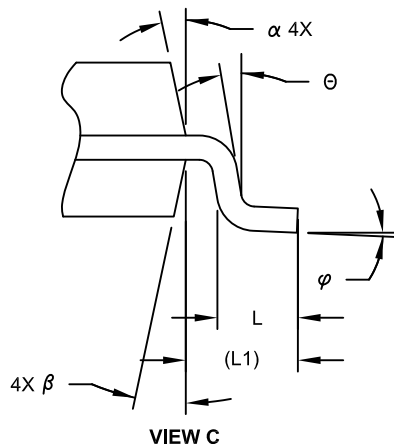

Dimension Limits	Units	MILLIMETERS		
		MIN	NOM	MAX
Number of Pins	N	28		
Pitch	e	1.27 BSC		
Overall Height	A	-	-	2.65
Molded Package Thickness	A2	2.05	-	-
Standoff §	A1	0.10	-	0.30
Overall Width	E	10.30 BSC		
Molded Package Width	E1	7.50 BSC		
Overall Length	D	17.90 BSC		
Chamfer (Optional)	h	0.25	-	0.75
Foot Length	L	0.40	-	1.27
Footprint	L1	1.40 REF		
Lead Angle	θ	0°	-	-
Foot Angle	φ	0°	-	8°
Lead Thickness	c	0.18	-	0.33
Lead Width	b	0.31	-	0.51
Mold Draft Angle Top	α	5°	-	15°
Mold Draft Angle Bottom	β	5°	-	15°

**Notes:**

- Pin 1 visual index feature may vary, but must be located within the hatched area.
- § Significant Characteristic
- Dimension D does not include mold flash, protrusions or gate burrs, which shall not exceed 0.15 mm per end. Dimension E1 does not include interlead flash or protrusion, which shall not exceed 0.25 mm per side.
- Dimensioning and tolerancing per ASME Y14.5M
  - BSC: Basic Dimension. Theoretically exact value shown without tolerances.
  - REF: Reference Dimension, usually without tolerance, for information purposes only.
- Datums A & B to be determined at Datum H.

Microchip Technology Drawing C04-052C Sheet 2 of 2

# PIC24F16KA102 FAMILY

28-Lead Plastic Small Outline (SO) - Wide, 7.50 mm Body [SOIC]

**Note:** For the most current package drawings, please see the Microchip Packaging Specification located at <http://www.microchip.com/packaging>

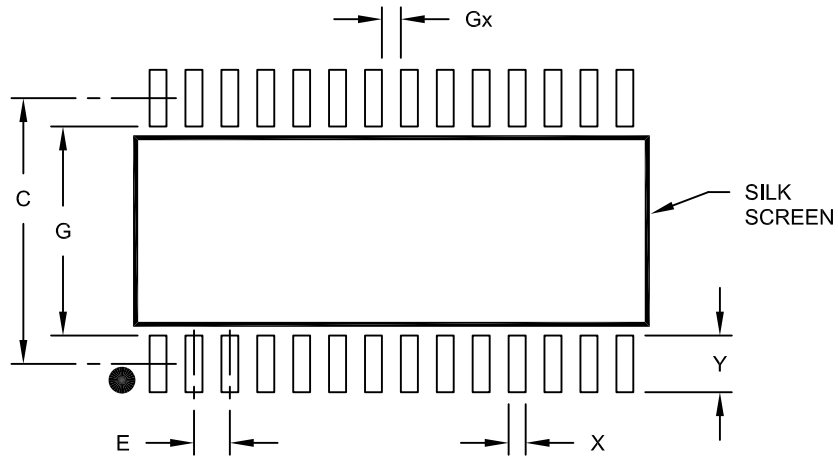

## RECOMMENDED LAND PATTERN

Dimension Limits	Units	MILLIMETERS		
		MIN	NOM	MAX
Contact Pitch	E	1.27 BSC		
Contact Pad Spacing	C		9.40	
Contact Pad Width (X28)	X			0.60
Contact Pad Length (X28)	Y			2.00
Distance Between Pads	Gx	0.67		
Distance Between Pads	G	7.40		

**Notes:**

1. Dimensioning and tolerancing per ASME Y14.5M

BSC: Basic Dimension. Theoretically exact value shown without tolerances.

Microchip Technology Drawing No. C04-2052A



# PIC24F16KA102 FAMILY

## 20-Lead Plastic Quad Flat, No Lead Package (MQ) – 5x5x0.9 mm Body [QFN]

**Note:** For the most current package drawings, please see the Microchip Packaging Specification located at <http://www.microchip.com/packaging>

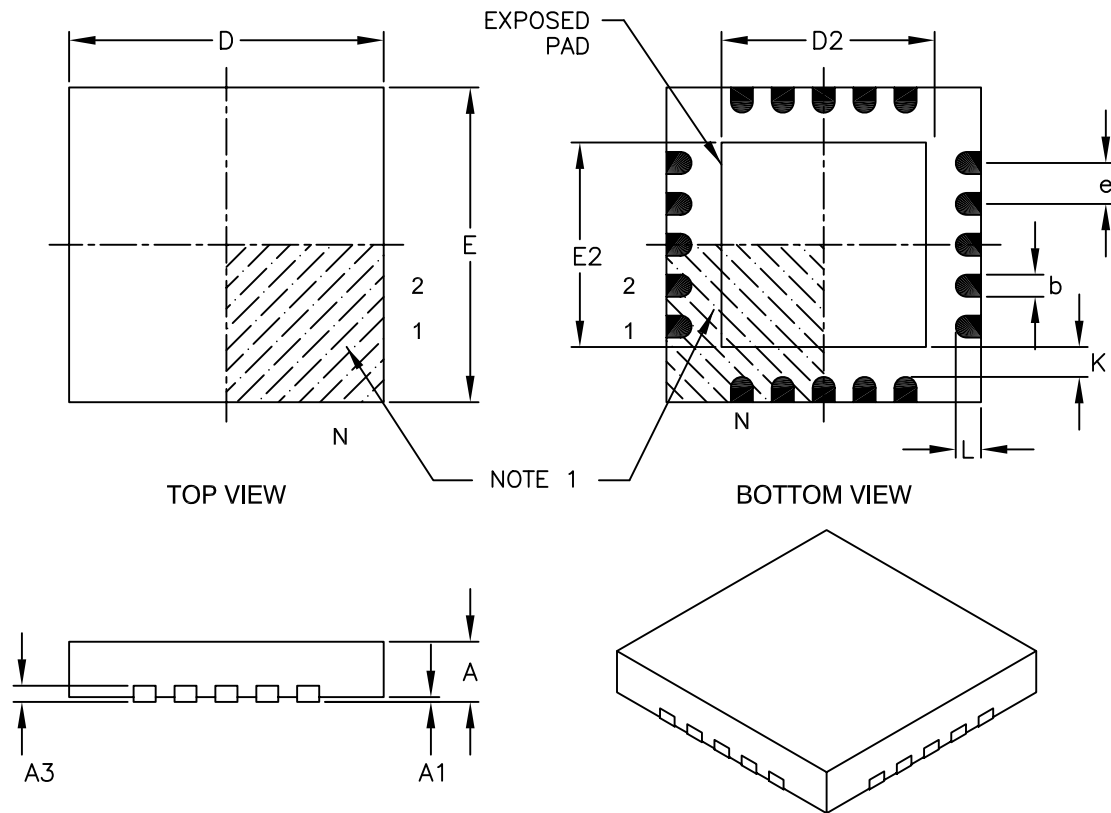

Dimension Limits	Units	MILLIMETERS		
		MIN	NOM	MAX
Number of Pins	N	20		
Pitch	e	0.65 BSC		
Overall Height	A	0.80	0.90	1.00
Standoff	A1	0.00	0.02	0.05
Contact Thickness	A3	0.20 REF		
Overall Width	E	5.00 BSC		
Exposed Pad Width	E2	3.15	3.25	3.35
Overall Length	D	5.00 BSC		
Exposed Pad Length	D2	3.15	3.25	3.35
Contact Width	b	0.25	0.30	0.35
Contact Length	L	0.35	0.40	0.45
Contact-to-Exposed Pad	K	0.20	-	-

**Notes:**

- Pin 1 visual index feature may vary, but must be located within the hatched area.
- Package is saw singulated.
- Dimensioning and tolerancing per ASME Y14.5M.

BSC: Basic Dimension. Theoretically exact value shown without tolerances.

REF: Reference Dimension, usually without tolerance, for information purposes only.

Microchip Technology Drawing C04-139B

# PIC24F16KA102 FAMILY

20-Lead Plastic Quad Flat, No Lead Package (MQ) - 5x5 mm Body [QFN]  
With 0.40mm Contact Length

**Note:** For the most current package drawings, please see the Microchip Packaging Specification located at <http://www.microchip.com/packaging>



RECOMMENDED LAND PATTERN

Dimension Limits	Units	MILLIMETERS		
		MIN	NOM	MAX
Contact Pitch	E	0.65 BSC		
Optional Center Pad Width	W2			3.35
Optional Center Pad Length	T2			3.35
Contact Pad Spacing	C1		4.50	
Contact Pad Spacing	C2		4.50	
Contact Pad Width (X20)	X1			0.40
Contact Pad Length (X20)	Y1			0.55
Distance Between Pads	G	0.20		

Notes:

1. Dimensioning and tolerancing per ASME Y14.5M

BSC: Basic Dimension. Theoretically exact value shown without tolerances.

Microchip Technology Drawing No. C04-2139A

# PIC24F16KA102 FAMILY

## 28-Lead Plastic Quad Flat, No Lead Package (ML) – 6x6 mm Body [QFN] with 0.55 mm Contact Length

**Note:** For the most current package drawings, please see the Microchip Packaging Specification located at <http://www.microchip.com/packaging>



		Units	MILLIMETERS		
Dimension Limits			MIN	NOM	MAX
Number of Pins	N		28		
Pitch	e		0.65 BSC		
Overall Height	A		0.80	0.90	1.00
Standoff	A1		0.00	0.02	0.05
Contact Thickness	A3		0.20 REF		
Overall Width	E		6.00 BSC		
Exposed Pad Width	E2		3.65	3.70	4.20
Overall Length	D		6.00 BSC		
Exposed Pad Length	D2		3.65	3.70	4.20
Contact Width	b		0.23	0.30	0.35
Contact Length	L		0.50	0.55	0.70
Contact-to-Exposed Pad	K		0.20	–	–

**Notes:**

- Pin 1 visual index feature may vary, but must be located within the hatched area.
- Package is saw singulated.
- Dimensioning and tolerancing per ASME Y14.5M.

BSC: Basic Dimension. Theoretically exact value shown without tolerances.

REF: Reference Dimension, usually without tolerance, for information purposes only.

Microchip Technology Drawing C04-105B

# PIC24F16KA102 FAMILY

## 28-Lead Plastic Quad Flat, No Lead Package (ML) – 6x6 mm Body [QFN] with 0.55 mm Contact Length

**Note:** For the most current package drawings, please see the Microchip Packaging Specification located at <http://www.microchip.com/packages>



RECOMMENDED LAND PATTERN

Dimension	Units	MILLIMETERS		
		MIN	NOM	MAX
Contact Pitch	E	0.65 BSC		
Optional Center Pad Width	W2			4.25
Optional Center Pad Length	T2			4.25
Contact Pad Spacing	C1		5.70	
Contact Pad Spacing	C2		5.70	
Contact Pad Width (X28)	X1			0.37
Contact Pad Length (X28)	Y1			1.00
Distance Between Pads	G	0.20		

Notes:

1. Dimensioning and tolerancing per ASME Y14.5M

BSC: Basic Dimension. Theoretically exact value shown without tolerances.

Microchip Technology Drawing No. C04-2105A

## APPENDIX A: REVISION HISTORY

### Revision A (November 2008)

Original data sheet for the PIC24F16KA102 family of devices.

### Revision B (March 2009)

**Section 29.0 “Electrical Characteristics”** was revised and minor text edits were made throughout the document.

### Revision C (October 2011)

- Changed all instances of DSWSRC to DSWAKE.
- Corrected [Example 5-2](#).
- Corrected [Example 5-4](#).
- Corrected [Example 6-1](#).
- Corrected [Example 6-3](#).
- Added a comment to [Example 6-5](#).
- Corrected [Figure 9-1](#) to connect the SOSC1 and SOSCO pins to the Schmitt trigger correctly.
- Added register descriptions for PMD1, PMD2, PMD3 and PMD4.
- Added note that RTCC will run in Reset.
- Corrected time values of ADCS (AD1CON3<5:0>).
- Corrected CH0SB and CH0SA (AD1CHS<11:8> and AD1CHS<3:0>) to correctly reference AVDD and AN3.
- Added description of PGCF15 and PGCF14 (AD1PCFG<15:14>).
- Edited [Figure 22-2](#) to correctly reference RIC and the A/D capacitance.
- Changed all references from CTEDG1 to CTED1.
- Changed all references from CTEDG2 to CTED2.
- Changed description of CMIDL: it used to say it disables all comparators in Idle, now only disables interrupts in Idle mode.
- Changed all references of RTCKSEL to RTCOSC.
- Changed all references of DSLPBOR to DSBOR.
- Changed all references of DSWCKSEL to DSWDTOSC.
- Imported Figure 40-9 from PIC24F FRM, Section 40.
- Added spec for BOR hysteresis.
- Edited Note 1 for [Table 29-5](#) to further describe LPBOR.
- Edited max values of DC20d and DC20e on [Table 29-6](#).
- Edited typical value for DC61-DC61c in [Table 29-8](#).
- Edited Note 2 of [Table 29-8](#).
- Added Note 5 to [Table 29-9](#).
- Added [Table 29-15](#).
- Added AD08 and AD09 in [Table 29-26](#).
- Added Note 3 to [Table 29-26](#).
- Imported Figure 40.10 from PIC24F FRM, Section 40.
- Deleted TVREG spec.
- Imported Figure 15-5 from PIC24F FRM, Section 15.
- Imported Table 15-4 from PIC24F FRM, Section 15.
- Imported Figure 16-22 from PIC24F FRM, Section 16.
- Imported Table 16-9 from PIC24F FRM, Section 16.
- Imported Figure 16-23 from PIC24F FRM, Section 16.
- Imported Table 16-10 from PIC24F FRM, Section 16.
- Imported Figure 21-24 from PIC24F FRM, Section 21.
- Imported Figure 21-25 from PIC24F FRM, Section 21.
- Imported Table 21-5 from PIC24F FRM, Section 21.
- Imported Figure 23-17 from PIC24F FRM, Section 23.
- Imported Table 23-3 from PIC24F FRM, Section 23.
- Imported Figure 23-18 from PIC24F FRM, Section 23.
- Imported Table 23-4 from PIC24F FRM, Section 23.
- Imported Figure 23-19 from PIC24F FRM, Section 23.
- Imported Table 23-5 from PIC24F FRM, Section 23.
- Imported Figure 23-20 from PIC24F FRM, Section 23.
- Imported Table 23-6 from PIC24F FRM, Section 23.
- Imported Figure 24-33 from PIC24F FRM, Section 24.
- Imported Table 24-6 from PIC24F FRM, Section 24.
- Imported Figure 24-34 from PIC24F FRM, Section 24.
- Imported Table 24-7 from PIC24F FRM, Section 24.
- Imported Figure 24-35 from PIC24F FRM, Section 24.
- Imported Table 24-8 from PIC24F FRM, Section 24.
- Imported Figure 24-36 from PIC24F FRM, Section 24.
- Imported Table 24-9 from PIC24F FRM, Section 24.

# PIC24F16KA102 FAMILY

---

NOTES:

# PIC24F16KA102 FAMILY

## INDEX

### A

A/D	
10-Bit High-Speed A/D Converter	173
A/D Characteristics	
Conversion Timing Requirements	234
Module Specifications	235
A/D Converter	
Analog Input Model	181
Transfer Function	182
AC Characteristics	
Capacitive Loading Requirements on	
Output Pins	231
Comparator Timings	237
Comparator Voltage Reference Settling	
Time Specifications	237
Input Capture	244
Internal RC Accuracy	233
Load Conditions for Device Timing	
Specifications	231
Output Capture	244
Reset, Watchdog Timer, Oscillator Start-up Timer,	
Power-up Timer and Brown-out Reset	
Timing Requirements	239
Specifications	234
Assembler	
MPASM Assembler	204

### B

Baud Rate Generator	
Setting as a Bus Master	141
Block Diagrams	
10-Bit High-Speed A/D Converter	174
16-Bit Timer1	115
Accessing Program Memory with	
Table Instructions	43
CALL Stack Frame	41
Comparator Module	183
Comparator Voltage Reference	187
CPU Programmer's Model	25
CRC Reconfigured for Polynomial	168
CRC Shifter Details	167
CTMU Connections and Internal Configuration for	
Capacitance Measurement	189
CTMU Typical Connections and Internal	
Configuration for Pulse Delay Generation	190
CTMU Typical Connections and Internal	
Configuration for Time Measurement	190
Data Access from Program Space	
Address Generation	42
Data EEPROM Addressing with TBLPAG,	
NVM Address Registers	53
High/Low-Voltage Detect (HLVD)	171
I <sup>2</sup> C Module	140
Individual Comparator Configurations	184
Input Capture	123
Output Compare	128
PIC24F CPU Core	24
PIC24F16KA102 Family (General)	12
PSV Operation	44

Reset System	57
RTCC	155
Shared I/O Port Structure	113
Simplified UART	147
SPI1 Module (Enhanced Buffer Mode)	133
SPI1 Module (Standard Buffer Mode)	132
System Clock	91
Timer2 (16-Bit Synchronous Mode)	119
Timer2/3 (32-Bit Mode)	118
Timer3 (16-Bit Synchronous Mode)	119
Watchdog Timer (WDT)	201
Brown-out Reset (BOR)	61

### C

C Compilers	
MPLAB C18	204
Charge Time Measurement Unit. See CTMU.	
Code Examples	
Data EEPROM Bulk Erase	55
Data EEPROM Unlock Sequence	51
Erasing a Program Memory Row,	
'C' Language Code	48
Erasing a Program Memory Row,	
Assembly Language Code	48
I/O Port Write/Read	114
Initiating a Programming Sequence,	
'C' Language Code	50
Initiating a Programming Sequence,	
Assembly Language Code	50
Loading the Write Buffers, 'C' Language Code	49
Loading the Write Buffers, Assembly	
Language Code	49
PWRSAV Instruction Syntax	101
Reading Data EEPROM Using the	
TBLRD Command	56
Sequence for Clock Switching	98
Setting the RTCWREN Bit	156
Single-Word Erase	54
Single-Word Write to Data EEPROM	55
Code Protection	202
Comparator	183
Comparator Voltage Reference	187
Configuration	187
Configuration Bits	193
Core Features	9
CPU	
Arithmetic (Logic Unit (ALU))	27
Control Registers	26
Core Registers	24
Programmer's Model	23
CRC	
Operation in Power Save Modes	168
User Interface	168
CTMU	
Measuring Capacitance	189
Measuring Time	190
Pulse Generation and Delay	190
Customer Change Notification Service	275
Customer Notification Service	275
Customer Support	275

# PIC24F16KA102 FAMILY

## D

Data EEPROM	
Bulk Erase .....	55
Erasing .....	54
Operations .....	53
Programming	
Reading Data EEPROM .....	56
Single-Word Write .....	55
Data Memory	
Address Space .....	31
Memory Map .....	31
Near Data Space .....	32
Organization, Alignment .....	32
SFR Space .....	32
Software Stack .....	41
Space Width .....	31
DC Characteristics	
Brown-out Reset Trip Points .....	219
Comparator Specifications .....	230
Comparator Voltage Reference Specifications .....	230
CTMU Current Source Specifications .....	230
Data EEPROM Memory .....	229
High/Low-Voltage Detect .....	218
I/O Pin Input Specifications .....	227
I/O Pin Output Specifications .....	228
Idle Current <i>I</i> <sub>IDLE</sub> .....	222
Internal Voltage References .....	230
Operating Current <i>I</i> <sub>DD</sub> .....	220
Power-Down Current <i>I</i> <sub>PD</sub> .....	224
Program Memory .....	229
Temperature and Voltage Specifications .....	218
Thermal Operating Conditions .....	217
Thermal Packaging Characteristics .....	217
Deep Sleep	
Checking, Clearing Status .....	104
Entering .....	102
Sequence .....	102, 103
Exiting .....	103
I/O Pins .....	103
POR .....	104
Sequence Summary .....	104
WDT .....	104
Deep Sleep BOR (DSBOR) .....	61
Development Support .....	203
Device Features (Summary) .....	11
Doze Mode .....	107

## E

Electrical Characteristics	
Absolute Maximum Ratings .....	215
V/F Graphs (Industrial, Extended) .....	216
V/F Graphs (Industrial) .....	216
Equations	
A/D Conversion Clock Period .....	181
Baud Rate Reload Calculation .....	141
Calculating the PWM Period .....	126
Calculation for Maximum PWM Resolution .....	126
CRC .....	167
Device and SPI Clock Speed Relationship .....	138
UART Baud Rate with BRGH = 0 .....	148
UART Baud Rate with BRGH = 1 .....	148
Errata .....	8

## Examples

Baud Rate Error Calculation (BRG) .....	148
PWM Frequencies, Resolutions at 16 MIPS .....	127
PWM Frequencies, Resolutions at 4 MIPS .....	127
PWM Period, Duty Cycle Calculations .....	127

## F

Flash and Data EEPROM	
Programming	
Control Registers .....	51
Flash and Data EEPROM Programming	
Control Registers	
NVM Address Registers (NVMADRU, NVMADR) .....	53
NVMCON .....	51
NVMKEY .....	51
Flash Program Memory	
Control Registers .....	46
Enhanced ICSP Operation .....	46
Programming Algorithm .....	48
Programming Operations .....	46
RTSP Operation .....	46
Table Instructions .....	45

## H

High/Low-Voltage Detect (HLVD) .....	171
--------------------------------------	-----

## I

I/O Ports	
Analog Pins Configuration .....	114
Input Change Notification .....	114
Open-Drain Configuration .....	114
Parallel (PIO) .....	113
<i>i</i> <sup>2</sup> C	
Clock Rates .....	141
Communicating as Master in Single Master Environment .....	139
Pin Remapping Options .....	139
Reserved Addresses .....	141
Slave Address Masking .....	141
In-Circuit Debugger .....	202
In-Circuit Serial Programming (ICSP) .....	202
Input Capture .....	123
Instruction Set	
Opcode Symbols .....	208
Overview .....	209
Summary .....	207

Inter-Integrated Circuit. See *I*<sup>2</sup>C.

Internet Address .....	275
------------------------	-----

## Interrupts

Alternate Interrupt Vector Table (AIVT) .....	63
Control and Status Registers .....	66
Implemented Vectors .....	65
Interrupt Service Routine (ISR) .....	90
Interrupt Vector Table (IVT) .....	63
Reset Sequence .....	63
Setup and Service Procedures .....	90
Trap Service Routine (TSR) .....	90
Trap Vectors .....	65
Vector Table .....	64



# PIC24F16KA102 FAMILY

## M

Microchip Internet Web Site .....	275
MPLAB ASM30 Assembler, Linker, Librarian .....	204
MPLAB Integrated Development Environment Software .....	203
MPLAB PM3 Device Programmer .....	206
MPLAB REAL ICE In-Circuit Emulator System .....	205
MPLINK Object Linker/MPLIB Object Librarian .....	204

## N

Near Data Space .....	32
-----------------------	----

## O

Oscillator Configuration	
Bit Values for Clock Selection .....	92
Clock Switching .....	97
Sequence .....	97
CPU Clocking Scheme .....	92
Initial Configuration on POR .....	92
Reference Clock Output .....	98
Output Compare	
Continuous Output Pulse Generation .....	125
Single Output Pulse Generation .....	125

## P

Packaging	
Details .....	253
Marking .....	251
Pinout Descriptions .....	13–16
Power-Saving Features .....	101
Clock Frequency, Clock Switching .....	101
Instruction-Based Modes .....	101
Deep Sleep .....	102
Idle .....	102
Sleep .....	101
Product Identification System .....	277
Program and Data Memory	
Access Using Table Instructions .....	43
Program Space Visibility .....	44
Program and Data Memory Spaces	
Interfacing, Addressing .....	41
Program Memory	
Address Space .....	29
Configuration Word Addresses .....	30
Memory Map .....	29
Program Verification .....	202
Programmable Cyclic Redundancy Check (CRC)	
Generator .....	167
Pulse-Width Modulation. See PWM.	

## R

Reader Response .....	276
Register Maps	
A/D .....	38
Clock Control .....	40
CPU Core .....	33
CRC .....	39
CTMU .....	38
Deep Sleep .....	40
Dual Comparator .....	39
I <sup>2</sup> C .....	36
ICN .....	34
Input Capture .....	35
Interrupt Controller .....	34
NVM .....	40

Output Compare .....	35
Pad Configuration .....	37
PMD .....	40
PORTA .....	37
PORTB .....	37
RTCC .....	39
SPI .....	36
Timer .....	35
UART .....	36

## Registers

AD1CHS (A/D Input Select) .....	178
AD1CON1 (A/D Control 1) .....	175
AD1CON2 (A/D Control 2) .....	176
AD1CON3 (A/D Control 3) .....	177
AD1CSSL (A/D Input Scan Select, Low) .....	180
AD1PCFG (A/D Port Configuration) .....	179
ALCFGRPT (Alarm Configuration) .....	159
ALMINSEC (Alarm Minutes and Seconds Value) .....	163
ALMTHDY (Alarm Month and Day Value) .....	162
ALWDHR (Alarm Weekday and Hours Value) .....	162
CLKDIV (Clock Divider) .....	95
CMSTAT (Comparator Status) .....	186
CMxCON (Comparator x Control) .....	185
CORCON (CPU Control) .....	27, 68
CRCCON (CRC Control) .....	169
CRCXOR (CRC XOR Polynomial) .....	170
CTMUCON (CTMU Control) .....	191
CTMUICON (CTMU Current Control) .....	192
CVRCON (Comparator Voltage Reference Control) .....	188
DEVID (Device ID) .....	200
DEVREV (Device Revision) .....	200
DSCON (Deep Sleep Control) .....	105
DSWAKE (Deep Sleep Wake-up Source) .....	106
FBS (Boot Segment Configuration) .....	193
FDS (Deep Sleep Configuration) .....	199
FGS (General Segment Configuration) .....	194
FICD (In-Circuit Debugger Configuration) .....	198
FOSC (Oscillator Configuration) .....	195
FOSCSEL (Oscillator Selection Configuration) .....	194
FPOR (Reset Configuration) .....	197
FWDT (Watchdog Timer Configuration) .....	196
HLVDCON (High/Low-Voltage Detect Control) .....	172
I2C1CON (I2C1 Control) .....	142
I2C1MSK (I2C1 Slave Mode Address Mask) .....	146
I2C1STAT (I2C1 Status) .....	144
IC1CON (Input Capture 1 Control) .....	124
IEC0 (Interrupt Enable Control 0) .....	75
IEC1 (Interrupt Enable Control 1) .....	76
IEC3 (Interrupt Enable Control 3) .....	77
IEC4 (Interrupt Enable Control 4) .....	78
IFS0 (Interrupt Flag Status 0) .....	71
IFS1 (Interrupt Flag Status 1) .....	72
IFS3 (Interrupt Flag Status 3) .....	73
IFS4 (Interrupt Flag Status 4) .....	74
INTCON1 (Interrupt Control 1) .....	69
INTCON2 (Interrupt Control 2) .....	70
INTTREG Interrupt Control and Status .....	89
IPC0 (Interrupt Priority Control 0) .....	79
IPC1 (Interrupt Priority Control 1) .....	80
IPC15 (Interrupt Priority Control 15) .....	86
IPC16 (Interrupt Priority Control 16) .....	87
IPC18 (Interrupt Priority Control 18) .....	88
IPC19 (Interrupt Priority Control 19) .....	88

# PIC24F16KA102 FAMILY

IPC2 (Interrupt Priority Control 2) .....	81
IPC3 (Interrupt Priority Control 3) .....	82
IPC4 (Interrupt Priority Control 4) .....	83
IPC5 (Interrupt Priority Control 5) .....	84
IPC7 (Interrupt Priority Control 7) .....	85
MINSEC (RTCC Minutes and Seconds Value) .....	161
MTHDY (RTCC Month and Day Value) .....	160
NVMCON (Flash Memory Control) .....	47
NVMCON (Nonvolatile Memory Control) .....	52
OC1CON (Output Compare 1 Control) .....	129
OSCCON (Oscillator Control) .....	93
OSCTUN (FRC Oscillator Tune) .....	96
PADCFG1 (Pad Configuration Control) .....	130, 146, 158
PMD1 (Peripheral Module Disable 1) .....	108
PMD2 (Peripheral Module Disable 2) .....	109
PMD3 (Peripheral Module Disable 3) .....	110
PMD4 (Peripheral Module Disable 4) .....	111
RCFGCAL (RTCC Calibration and Configuration) .....	157
RCON (Reset Control) .....	58
REFOCON (Reference Oscillator Control) .....	99
SPI1CON1 (SPI1 Control 1) .....	136
SPI1CON2 (SPI1 Control 2) .....	137
SPI1STAT (SPI1 Status and Control) .....	134
SR (ALU STATUS) .....	26, 67
T1CON (Timer1 Control) .....	116
T2CON (Timer2 Control) .....	120
T3CON (Timer3 Control) .....	121
UxMODE (UARTx Mode) .....	150
UxRXREG (UARTx Receive) .....	154
UxSTA (UARTx Status and Control) .....	152
UxTXREG (UARTx Transmit) .....	154
WKDYHR (RTCC Weekday and Hours Value) .....	161
YEAR (RTCC Year Value) .....	160
<b>Resets</b>	
Clock Source Selection .....	60
Delay Times for Various Device Resets .....	60
Device Times .....	60
RCON Flags Operation .....	59
SFR States .....	61
Revision History .....	269
<b>RTCC</b> .....	155
Alarm Configuration .....	164
Alarm Mask Settings (figure) .....	165
Calibration .....	164
Register Mapping .....	156
Source Clock .....	155
Selection .....	156
Write Lock .....	156
<b>S</b>	
Selective Peripheral Power Control .....	107
Serial Peripheral Interface. <i>See</i> SPI.	
SFR Space .....	32
Software Simulator (MPLAB SIM) .....	205
Software Stack .....	41
<b>T</b>	
Timer1 .....	115
Timer2/3 .....	117
<b>Timing Diagrams</b>	
Baud Rate Generator Output .....	239, 240
Brown-out Reset Characteristics .....	219
CLKO and I/O Timing .....	236
External Clock .....	232
I <sup>2</sup> C Bus Data (Master Mode) .....	240
I <sup>2</sup> C Bus Data (Slave Mode) .....	242
I <sup>2</sup> C Bus Start/Stop Bits (Master Mode) .....	240
I <sup>2</sup> C Bus Start/Stop Bits (Slave Mode) .....	242
Input Capture .....	244
Output Compare .....	244
PWM Requirements .....	245
Reset, Watchdog Timer, Oscillator Start-up Timer, Power-up Timer Characteristics .....	238
SPIx Master Mode (CKE = 0) .....	246
SPIx Master Mode (CKE = 1) .....	247
SPIx Slave Mode (CKE = 0) .....	248
SPIx Slave Mode (CKE = 1) .....	249
Start Bit Edge Detection .....	243
<b>Timing Requirements</b>	
CLKO and I/O .....	236
External Clock .....	232
I <sup>2</sup> C Bus Data (Master Mode) .....	240, 241
I <sup>2</sup> C Bus Data (Slave Mode) .....	243
I <sup>2</sup> C Bus Start/Stop Bit (Slave Mode) .....	242
PLL Clock Specifications .....	233
PWM .....	245
SPIx Master Mode (CKE = 0) .....	246
SPIx Master Mode (CKE = 1) .....	247
SPIx Slave Mode (CKE = 0) .....	248
SPIx Slave Mode (CKE = 1) .....	249
<b>U</b>	
UART .....	147
Baud Rate Generator (BRG) .....	148
Break and Sync Transmit Sequence .....	149
IrDA Support .....	149
Operation of $\overline{UxCTS}$ and $\overline{UxRTS}$ Control Pins .....	149
Receiving in 8-Bit or 9-Bit Data Mode .....	149
Transmitting in 8-Bit Data Mode .....	149
Transmitting in 9-Bit Data Mode .....	149
<b>W</b>	
Watchdog Timer	
Deep Sleep (DSWDT) .....	202
Watchdog Timer (WDT) .....	201
Windowed Operation .....	201
WWW Address .....	275
WWW, On-Line Support .....	8

# PIC24F16KA102 FAMILY

---

## THE MICROCHIP WEB SITE

Microchip provides online support via our WWW site at [www.microchip.com](http://www.microchip.com). This web site is used as a means to make files and information easily available to customers. Accessible by using your favorite Internet browser, the web site contains the following information:

- **Product Support** – Data sheets and errata, application notes and sample programs, design resources, user's guides and hardware support documents, latest software releases and archived software
- **General Technical Support** – Frequently Asked Questions (FAQ), technical support requests, online discussion groups, Microchip consultant program member listing
- **Business of Microchip** – Product selector and ordering guides, latest Microchip press releases, listing of seminars and events, listings of Microchip sales offices, distributors and factory representatives

## CUSTOMER CHANGE NOTIFICATION SERVICE

Microchip's customer notification service helps keep customers current on Microchip products. Subscribers will receive e-mail notification whenever there are changes, updates, revisions or errata related to a specified product family or development tool of interest.

To register, access the Microchip web site at [www.microchip.com](http://www.microchip.com). Under "Support", click on "Customer Change Notification" and follow the registration instructions.

## CUSTOMER SUPPORT

Users of Microchip products can receive assistance through several channels:

- Distributor or Representative
- Local Sales Office
- Field Application Engineer (FAE)
- Technical Support
- Development Systems Information Line

Customers should contact their distributor, representative or field application engineer (FAE) for support. Local sales offices are also available to help customers. A listing of sales offices and locations is included in the back of this document.

**Technical support is available through the web site at: <http://microchip.com/support>**

# PIC24F16KA102 FAMILY

---

---

## READER RESPONSE

It is our intention to provide you with the best documentation possible to ensure successful use of your Microchip product. If you wish to provide your comments on organization, clarity, subject matter, and ways in which our documentation can better serve you, please FAX your comments to the Technical Publications Manager at (480) 792-4150.

Please list the following information, and use this outline to provide us with your comments about this document.

TO: Technical Publications Manager Total Pages Sent \_\_\_\_\_

RE: Reader Response

From: Name \_\_\_\_\_

Company \_\_\_\_\_

Address \_\_\_\_\_

City / State / ZIP / Country \_\_\_\_\_

Telephone: (\_\_\_\_\_) \_\_\_\_\_ - \_\_\_\_\_ FAX: (\_\_\_\_\_) \_\_\_\_\_ - \_\_\_\_\_

Application (optional):

Would you like a reply?  Y  N

Device: PIC24F16KA102 Family

Literature Number: DS39927C

Questions:

1. What are the best features of this document?

---

---

2. How does this document meet your hardware and software development needs?

---

---

3. Do you find the organization of this document easy to follow? If not, why?

---

---

4. What additions to the document do you think would enhance the structure and subject?

---

---

5. What deletions from the document could be made without affecting the overall usefulness?

---

---

6. Is there any incorrect or misleading information (what and where)?

---

---

7. How would you improve this document?

---

---

# PIC24F16KA102 FAMILY

## PRODUCT IDENTIFICATION SYSTEM

To order or obtain information, e.g., on pricing or delivery, refer to the factory or the listed sales office.

	<b>PIC 24 F 16 KA1 02 T - I / PT - XXX</b>	
<b>Microchip Trademark</b>	_____	
<b>Architecture</b>	_____	
<b>Flash Memory Family</b>	_____	
<b>Program Memory Size (KB)</b>	_____	
<b>Product Group</b>	_____	
<b>Pin Count</b>	_____	
<b>Tape and Reel Flag (if applicable)</b>	_____	
<b>Temperature Range</b>	_____	
<b>Package</b>	_____	
<b>Pattern</b>	_____	

<b>Architecture</b>	24 = 16-bit modified Harvard without DSP
<b>Flash Memory Family</b>	F = Flash program memory
<b>Product Group</b>	KA1 = General purpose microcontrollers
<b>Pin Count</b>	01 = 20-pin 02 = 28-pin
<b>Temperature Range</b>	I = -40°C to +85°C (Industrial) E = -40°C to +125°C (Extended)
<b>Package</b>	SP = SPDIP SO = SOIC SS = SSOP ML = QFN P = PDIP
<b>Pattern</b>	Three-digit QTP, SQTP, Code or Special Requirements (blank otherwise) ES = Engineering Sample

### Examples:

- a) PIC24F16KA102-I/ML: General purpose, 16-Kbyte program memory, 28-pin, Industrial temp., QFN package.



# MICROCHIP

## Worldwide Sales and Service

### AMERICAS

**Corporate Office**  
2355 West Chandler Blvd.  
Chandler, AZ 85224-6199  
Tel: 480-792-7200  
Fax: 480-792-7277  
Technical Support:  
<http://www.microchip.com/support>  
Web Address:  
[www.microchip.com](http://www.microchip.com)

**Atlanta**  
Duluth, GA  
Tel: 678-957-9614  
Fax: 678-957-1455

**Boston**  
Westborough, MA  
Tel: 774-760-0087  
Fax: 774-760-0088

**Chicago**  
Itasca, IL  
Tel: 630-285-0071  
Fax: 630-285-0075

**Cleveland**  
Independence, OH  
Tel: 216-447-0464  
Fax: 216-447-0643

**Dallas**  
Addison, TX  
Tel: 972-818-7423  
Fax: 972-818-2924

**Detroit**  
Farmington Hills, MI  
Tel: 248-538-2250  
Fax: 248-538-2260

**Indianapolis**  
Noblesville, IN  
Tel: 317-773-8323  
Fax: 317-773-5453

**Los Angeles**  
Mission Viejo, CA  
Tel: 949-462-9523  
Fax: 949-462-9608

**Santa Clara**  
Santa Clara, CA  
Tel: 408-961-6444  
Fax: 408-961-6445

**Toronto**  
Mississauga, Ontario,  
Canada  
Tel: 905-673-0699  
Fax: 905-673-6509

### ASIA/PACIFIC

**Asia Pacific Office**  
Suites 3707-14, 37th Floor  
Tower 6, The Gateway  
Harbour City, Kowloon  
Hong Kong  
Tel: 852-2401-1200  
Fax: 852-2401-3431

**Australia - Sydney**  
Tel: 61-2-9868-6733  
Fax: 61-2-9868-6755

**China - Beijing**  
Tel: 86-10-8569-7000  
Fax: 86-10-8528-2104

**China - Chengdu**  
Tel: 86-28-8665-5511  
Fax: 86-28-8665-7889

**China - Chongqing**  
Tel: 86-23-8980-9588  
Fax: 86-23-8980-9500

**China - Hangzhou**  
Tel: 86-571-2819-3187  
Fax: 86-571-2819-3189

**China - Hong Kong SAR**  
Tel: 852-2401-1200  
Fax: 852-2401-3431

**China - Nanjing**  
Tel: 86-25-8473-2460  
Fax: 86-25-8473-2470

**China - Qingdao**  
Tel: 86-532-8502-7355  
Fax: 86-532-8502-7205

**China - Shanghai**  
Tel: 86-21-5407-5533  
Fax: 86-21-5407-5066

**China - Shenyang**  
Tel: 86-24-2334-2829  
Fax: 86-24-2334-2393

**China - Shenzhen**  
Tel: 86-755-8203-2660  
Fax: 86-755-8203-1760

**China - Wuhan**  
Tel: 86-27-5980-5300  
Fax: 86-27-5980-5118

**China - Xian**  
Tel: 86-29-8833-7252  
Fax: 86-29-8833-7256

**China - Xiamen**  
Tel: 86-592-2388138  
Fax: 86-592-2388130

**China - Zhuhai**  
Tel: 86-756-3210040  
Fax: 86-756-3210049

### ASIA/PACIFIC

**India - Bangalore**  
Tel: 91-80-3090-4444  
Fax: 91-80-3090-4123

**India - New Delhi**  
Tel: 91-11-4160-8631  
Fax: 91-11-4160-8632

**India - Pune**  
Tel: 91-20-2566-1512  
Fax: 91-20-2566-1513

**Japan - Yokohama**  
Tel: 81-45-471- 6166  
Fax: 81-45-471-6122

**Korea - Daegu**  
Tel: 82-53-744-4301  
Fax: 82-53-744-4302

**Korea - Seoul**  
Tel: 82-2-554-7200  
Fax: 82-2-558-5932 or  
82-2-558-5934

**Malaysia - Kuala Lumpur**  
Tel: 60-3-6201-9857  
Fax: 60-3-6201-9859

**Malaysia - Penang**  
Tel: 60-4-227-8870  
Fax: 60-4-227-4068

**Philippines - Manila**  
Tel: 63-2-634-9065  
Fax: 63-2-634-9069

**Singapore**  
Tel: 65-6334-8870  
Fax: 65-6334-8850

**Taiwan - Hsin Chu**  
Tel: 886-3-5778-366  
Fax: 886-3-5770-955

**Taiwan - Kaohsiung**  
Tel: 886-7-536-4818  
Fax: 886-7-330-9305

**Taiwan - Taipei**  
Tel: 886-2-2500-6610  
Fax: 886-2-2508-0102

**Thailand - Bangkok**  
Tel: 66-2-694-1351  
Fax: 66-2-694-1350

### EUROPE

**Austria - Wels**  
Tel: 43-7242-2244-39  
Fax: 43-7242-2244-393

**Denmark - Copenhagen**  
Tel: 45-4450-2828  
Fax: 45-4485-2829

**France - Paris**  
Tel: 33-1-69-53-63-20  
Fax: 33-1-69-30-90-79

**Germany - Munich**  
Tel: 49-89-627-144-0  
Fax: 49-89-627-144-44

**Italy - Milan**  
Tel: 39-0331-742611  
Fax: 39-0331-466781

**Netherlands - Drunen**  
Tel: 31-416-690399  
Fax: 31-416-690340

**Spain - Madrid**  
Tel: 34-91-708-08-90  
Fax: 34-91-708-08-91

**UK - Wokingham**  
Tel: 44-118-921-5869  
Fax: 44-118-921-5820

08/02/11

Компания «Океан Электроники» предлагает заключение долгосрочных отношений при поставках импортных электронных компонентов на взаимовыгодных условиях!

Наши преимущества:

- Поставка оригинальных импортных электронных компонентов напрямую с производств Америки, Европы и Азии, а так же с крупнейших складов мира;
- Широкая линейка поставок активных и пассивных импортных электронных компонентов (более 30 млн. наименований);
- Поставка сложных, дефицитных, либо снятых с производства позиций;
- Оперативные сроки поставки под заказ (от 5 рабочих дней);
- Экспресс доставка в любую точку России;
- Помощь Конструкторского Отдела и консультации квалифицированных инженеров;
- Техническая поддержка проекта, помощь в подборе аналогов, поставка прототипов;
- Поставка электронных компонентов под контролем ВП;
- Система менеджмента качества сертифицирована по Международному стандарту ISO 9001;
- При необходимости вся продукция военного и аэрокосмического назначения проходит испытания и сертификацию в лаборатории (по согласованию с заказчиком);
- Поставка специализированных компонентов военного и аэрокосмического уровня качества (Xilinx, Altera, Analog Devices, Intersil, Interpoint, Microsemi, Actel, Aeroflex, Peregrine, VPT, Syfer, Eurofarad, Texas Instruments, MS Kennedy, Miteq, Cobham, E2V, MA-COM, Hittite, Mini-Circuits, General Dynamics и др.);

Компания «Океан Электроники» является официальным дистрибьютором и эксклюзивным представителем в России одного из крупнейших производителей разъемов военного и аэрокосмического назначения «JONHON», а так же официальным дистрибьютором и эксклюзивным представителем в России производителя высокотехнологичных и надежных решений для передачи СВЧ сигналов «FORSTAR».



## JONHON

«JONHON» (основан в 1970 г.)

Разъемы специального, военного и аэрокосмического назначения:

(Применяются в военной, авиационной, аэрокосмической, морской, железнодорожной, горно- и нефтедобывающей отраслях промышленности)

«FORSTAR» (основан в 1998 г.)

ВЧ соединители, коаксиальные кабели, кабельные сборки и микроволновые компоненты:

(Применяются в телекоммуникациях гражданского и специального назначения, в средствах связи, РЛС, а так же военной, авиационной и аэрокосмической отраслях промышленности).



Телефон: 8 (812) 309-75-97 (многоканальный)

Факс: 8 (812) 320-03-32

Электронная почта: [ocean@oceanchips.ru](mailto:ocean@oceanchips.ru)

Web: <http://oceanchips.ru/>

Адрес: 198099, г. Санкт-Петербург, ул. Калинина, д. 2, корп. 4, лит. А