

16K-64K I²C Serial EEPROM with Software Write Protection Family Data Sheet

Device Selection Table

Part Number	Density	Page Size	Vcc Range	Package	Temp. Ranges
24CW16X	16-Kbit	32-byte	1.6-5.5	SN, OT, ST, MU	I
24CW32X	32-Kbit	32-byte	1.6-5.5	SN, OT, ST, MU	I
24CW64X	64-Kbit	32-byte	1.6-5.5	SN, OT, ST, MU, CS0, CS1	I

Note: 'X' in the part number refers to the preset hardware slave address. Refer to [Table 3-2](#) for additional information.

Features

- 16/32/64-Kbit EEPROM:
 - Internally organized as one 2048/4096/8192 x 8 bit block
 - Byte or page writes up to 32 bytes
 - Byte or sequential reads within a block
 - Self-timed write cycle (5 ms maximum)
- High-Speed I²C Interface:
 - Industry standard: 1 MHz, 400 kHz and 100 kHz
 - Output slope control to eliminate ground bounce
 - Schmitt trigger inputs for noise suppression
- Programmable Hardware Slave Address Bits:
 - Configurable via the Hardware Address Register (HAR)
- Versatile Data Protection Options:
 - Software write protection via the Write Protection Register (WPR)
- Operating Voltage Range of 1.6V to 5.5V
- Low-Power CMOS Technology:
 - Write current: 1.0 mA maximum at 5.5V
 - Read current: 1.0 mA maximum at 5.5V, 1 MHz
 - Standby Current: 1 µA at 5.5V
- High Reliability:
 - More than one million erase/write cycles
 - Data retention: >200 years
 - ESD protection: >4000V
- RoHS Compliant

Packages

- 8-Lead SOIC, 8-Lead TSSOP, 8-Pad UDFN, 5-Lead SOT-23 and Two 4-Ball CSP options

Package Types (not to scale)



Pin Function Table

Name	Function
Vss	Ground
SDA	Serial Data Pin
SCL	Serial Clock Input
Vcc	Supply Voltage

24CW16X/24CW32X/24CW64X

Description

The 24CW16X/24CW32X/24CW64X (24CW Series) devices provide 16-64 Kbits of Serial EEPROM utilizing an I²C (2-wire) serial interface. The 24CW Series is organized as 2048/4096/8192 bytes of 8 bits each (2-8 Kbytes). The 24CW Series is optimized for use in consumer and industrial applications, where reliable and dependable nonvolatile memory storage is essential. The 24CW Series allows up to eight devices to share a common I²C (2-wire) bus and is capable of operation across a broad voltage range (1.6V to 5.5V).

The 24CW Series contains a pair of programmable Configuration registers which allow certain device behaviors to be modified. These registers are the Write Protection Register and the Hardware Address Register.

The Write Protection Register (WPR) controls the valid address ranges of the EEPROM array that can be written. This allows the user to select the write protection behavior to be configured for software write protection.

The Hardware Address Register (HAR) controls the three hardware slave address bits. These bits determine which device addresses the 24CW Series will Acknowledge. Because the 24CW Series is a 4-pin device, the cascading feature is controlled by the HAR.

Once the desired software write protection and hardware slave address bits are set, these Configuration registers can be permanently locked, thereby preventing any further changes to the device operation.

System Configuration Using Serial EEPROMs



24CW16X/24CW32X/24CW64X

Block Diagram



24CW16X/24CW32X/24CW64X

1.0 ELECTRICAL CHARACTERISTICS

Absolute Maximum Ratings^(†)

V _{CC}	6.5V
All inputs and outputs w.r.t. V _{SS}	-0.6V to 6.5V
Storage temperature	-65°C to +150°C
Ambient temperature under bias.....	-40°C to +85°C
ESD protection on all pins.....	≥4 kV

† NOTICE: Stresses above those listed under 'Maximum ratings' may cause permanent damage to the device. This is a stress rating only and functional operation of the device at those or any other conditions above those indicated in the operational listings of this specification is not implied. Exposure to maximum rating conditions for an extended period of time may affect device reliability.

TABLE 1-1: DC CHARACTERISTICS

DC CHARACTERISTICS			Electrical Characteristics: Industrial (I): V _{CC} = 1.6V to 5.5V T _A = -40°C to +85°C			
Param. No.	Symbol	Characteristic	Min.	Max.	Units	Test Conditions
D1	V _{IH}	High-Level Input Voltage	V _{CC} x 0.7	V _{CC} + 0.5	V	
D2	V _{IL}	Low-Level Input Voltage	-0.6	V _{CC} x 0.3	V	
D3	V _{OL}	Low-Level Output Voltage	—	0.4	V	I _{OL} = 2.1 mA, V _{CC} = 3.0V
			—	0.2	V	I _{OL} = 0.15 mA, V _{CC} = 1.8V
D4	I _{LI}	Input Leakage Current	—	±1	µA	V _{IN} = V _{SS} or V _{CC}
			—	±1	µA	V _{IN} = V _{SS} or V _{CC}
D5	I _{LO}	Output Leakage Current	—	±1	µA	V _{OUT} = V _{SS} or V _{CC}
D6	C _{INT}	Internal Capacitance (all inputs and outputs)	—	7	pF	T _{AMB} = +25°C, FREQ = 1.0 MHz, V _{CC} = 5.5V (Note 1)
D7	I _{CCREAD}	Operating Current	—	0.3	mA	V _{CC} = 1.8V, F _{CLK} = 400 kHz
			—	1	mA	V _{CC} = 5.5V, F _{CLK} = 1 MHz
D8	I _{CCWRITE}	Operating Current	—	1	mA	V _{CC} = 5.5V, F _{CLK} = 1 MHz
D9	I _{CCS}	Standby Current	—	0.5	µA	SCL = SDA = V _{CC} = 1.8V
			—	1.0	µA	SCL = SDA = V _{CC} = 5.5V

Note 1: This parameter is not tested, but is ensured by characterization.

24CW16X/24CW32X/24CW64X

TABLE 1-2: AC CHARACTERISTICS

AC CHARACTERISTICS			Electrical Characteristics: Industrial (I): Vcc = 1.6V to 5.5V TA = -40°C to +85°C:			
Param. No.	Symbol	Characteristic	Min.	Max.	Units	Conditions
1	FCLK	Clock Frequency	—	1000	kHz	1.6V ≤ Vcc ≤ 5.5V
2	THIGH	Clock High Time	260	—	ns	1.6V ≤ Vcc ≤ 5.5V
3	TLOW	Clock Low Time	500	—	ns	1.6V ≤ Vcc ≤ 5.5V
4	TR	SDA and SCL Rise Time	—	1000	ns	1.6V ≤ Vcc ≤ 5.5V (Note 1)
5	TF	SDA and SCL Fall Time	—	300	ns	1.6V ≤ Vcc ≤ 5.5V (Note 1)
6	THD:STA	Start Condition Hold Time	260	—	ns	1.6V ≤ Vcc ≤ 5.5V
7	TSU:STA	Start Condition Setup Time	260	—	ns	1.6V ≤ Vcc ≤ 5.5V
8	THD:DAT	Data Input Hold Time	0	—	ns	(Note 2)
9	TSU:DAT	Data Input Setup Time	50	—	ns	1.6V ≤ Vcc ≤ 5.5V
10	TSU:STO	Stop Condition Setup Time	260	—	ns	1.6V ≤ Vcc ≤ 5.5V
11	TAA	Output Valid from Clock	—	450	ns	1.6V ≤ Vcc ≤ 5.5V
12	TBUF	Bus Free Time: Bus Time must be Free before a New Transmission can Start	500	—	ns	1.6V ≤ Vcc ≤ 5.5V
13	TSP	Input Filter Spike Suppression (SDA and SCL pins)	—	50	ns	(Note 3)
14	TWC	Write Cycle Time (byte or page)	—	5	ms	
15		Endurance	1,000,000	—	cycles	Vcc = 5.5V, +25°C, per data byte (Note 4)

- Note 1:** The rise/fall times must be less than the specified maximums in order to achieve the maximum clock frequencies specified for FCLK. Please refer to the I²C specification for applicable timings.
- 2:** As a transmitter, the device must provide an internal minimum delay time to bridge the undefined region of the falling edge of SCL to avoid unintended generation of Start or Stop conditions.
- 3:** Not 100% tested. CB = total capacitance of one bus line in pF.
- 4:** This parameter is not tested but ensured by characterization.

FIGURE 1-1: BUS TIMING DATA



24CW16X/24CW32X/24CW64X

1.1 Power-up Requirements and Reset Behavior

During a power-up sequence, the VCC supplied to the 24CW Series should monotonically rise from VSS to the minimum VCC level, as specified in [Table 1-1](#), with a slew rate no faster than 0.1V/μs.

1.1.1 DEVICE RESET

To prevent write operations or other spurious events from happening during a power-up sequence, the 24CW Series includes a Power-on Reset (POR) circuit. Upon power-up, the device will not respond to any commands until the VCC level crosses the internal voltage threshold (VPOR) that brings the device out of Reset and into Standby mode.

The system designer must ensure that instructions are not sent to the device until the VCC supply has reached a stable value greater than, or equal to, the minimum VCC level. Additionally, once the VCC is greater than, or equal to, the minimum VCC level, the master must wait at least tPUP before sending the first command to the device. See [Table 1-3](#) for the values associated with these power-up parameters.

If an event occurs in the system where the VCC level supplied to the 24CW Series drops below the maximum VPOR level specified, it is recommended that a full-power cycle sequence be performed by first driving the VCC pin to VSS, waiting at least the minimum tPOFF time, and then perform a new power-up sequence in compliance with the requirements defined in [Section 1.1 “Power-up Requirements and Reset Behavior”](#).

TABLE 1-3: POWER-UP CONDITIONS

Symbol	Parameter	Min.	Max.	Units
tPUP	Time Required after VCC is Stable before the Device can Accept Commands	100	—	μs
VPOR	Power-on Reset Threshold Voltage	—	1.5	V
tPOFF	Minimum Time at VCC = 0V between Power Cycles	1	—	ms

24CW16X/24CW32X/24CW64X

2.0 PIN DESCRIPTIONS

The descriptions of the pins are listed in [Table 2-1](#).

TABLE 2-1: PIN FUNCTION TABLE

Name	8-Lead SOIC	8-Lead TSSOP	5-Lead SOT23	8-Lead UDFN ⁽¹⁾	4-Ball CSP (CS0) ⁽²⁾	4-Ball CSP (CS1) ⁽³⁾	Function
NC	1	1	—	1	—	—	No Connect
NC	2	2	—	2	—	—	No Connect
NC	3	3	—	3	—	—	No Connect
VSS	4	4	2	4	A2	B2	Ground
SDA	5	5	3	5	B2	B1	Serial Data
SCL	6	6	1	6	B1	A2	Serial Clock
NC	7	7	5	7	—	—	No Connect
VCC	8	8	4	8	A1	A1	Device Power Supply

Note 1: The exposed pad on the UDFN package can be connected to VSS or left floating.

2: CS0 CSP ball pitch is 0.4x0.4mm.

3: CS1 CSP ball pitch is 0.5x0.4mm.

2.1 Serial Data (SDA)

This is a bidirectional pin used to transfer addresses and data into and out of the device. It is an open-drain terminal, therefore, the SDA bus requires a pull-up resistor to VCC (typical 10 kΩ for 100 kHz and 2 kΩ for 400 kHz and 1 MHz).

For normal data transfer, SDA is allowed to change only during SCL low. Changes during SCL high are reserved for indicating the Start and Stop conditions.

2.2 Serial Clock (SCL)

This input is used to synchronize the data transfer from and to the device.

24CW16X/24CW32X/24CW64X

3.0 MEMORY ORGANIZATION

3.1 EEPROM Organization

The 24CW Series is internally organized as 64/128/256 pages of 32 bytes each, depending on the density.

3.2 Device Configuration Registers

The 24CW Series contains two Configuration registers that modulate device operation and/or report on the current status of the device. These registers are:

- Write Protection Register (WPR)
- Hardware Address Register (HAR)

Once the device behavior is set as desired, the Configuration registers can be permanently locked (or set to read-only), thereby preventing any subsequent changes.

3.2.1 WRITE PROTECTION REGISTER

The Write Protection Register (WPR) allows for modification of the device write protection behavior. Refer to [Section 8.2 “Write Protection Register”](#) for additional information of the WPR.

3.2.2 HARDWARE ADDRESS REGISTER

The Hardware Address Register (HAR) allows for modification of the hardware slave address bits in the device address byte that the device will Acknowledge. Refer to [Section 8.3 “Hardware Address Register”](#) for additional information on the HAR.

3.3 Device Addressing

Communication with the 24CW Series begins with an 8-bit device address byte, comprised of a 7-bit slave address and a Read/Write Select (R/\overline{W}) bit. Since multiple slave devices can reside on the serial bus, each slave device must have its own unique device address, programmed in the HAR, so that the master can access each device independently.

The 7-bit slave address is constructed using two groups of bits. The first four bits contain the Device Type Identifier, followed by three bits containing the hardware slave address bits.

The 24CW Series will respond to only specific Device Type Identifiers, as shown in [Section 3.3.1 “Valid Device Address Byte Inputs”](#).

The 3-bit hardware slave address is comprised of bits A2, A1 and A0. These bits can be used to expand the address space by allowing up to eight devices with the same Device Type Identifiers on the bus. These hardware slave address bits must correlate with the values programmed in the HAR.

The device will respond to all valid device address byte combinations that it receives.

3.3.1 VALID DEVICE ADDRESS BYTE INPUTS

The 24CW Series will respond to the Device Type Identifiers, as shown in [Table 3-1](#).

3.3.1.1 Preset Slave Addresses

The 24CW Series is preset with a specific slave address. The preset slave address bits are embedded in the base part number, as shown in [Table 3-2](#).

TABLE 3-1: TABLE OF VALID DEVICE ADDRESS BYTES

Access Region	Device Type Identifier				Hardware Slave Address			Read/Write Select
	Bit 7	Bit 6	Bit 5	Bit 4	Bit 3	Bit 2	Bit 1	Bit 0
EEPROM	1	0	1	0	A2	A1	A0	R/\overline{W}
Configuration Registers	1	0	1	0	A2	A1	A0	R/\overline{W}

Note: The access region is selected according to bit 7 of the first word address byte. Refer to [Section 3.3.2 “Word Address Bytes”](#) for additional information.

24CW16X/24CW32X/24CW64X

TABLE 3-2: DEVICE PRESET SLAVE ADDRESS

Part Number Series 24CWXXX	Hardware Slave Address Bits		
	A2	A1	A0
24CWXX0 ⁽¹⁾	0	0	0
24CWXX1 ^(1,2)	0	0	1
24CWXX2 ^(1,2)	0	1	0
24CWXX3 ^(1,2)	0	1	1
24CWXX4 ^(1,2)	1	0	0
24CWXX5 ^(1,2)	1	0	1
24CWXX6 ^(1,2)	1	1	0
24CWXX7 ^(1,2)	1	1	1

- Note 1:** 'XX' in the part number varies depending on the density.
- 2:** Contact your local sales representative for hardware slave address availability.

3.3.1.2 Read/Write Select Bit

The eighth bit (bit 0) of the device address byte is the Read/Write Select (R/W) bit. A read operation is initiated if this bit is a logic '1' and a write operation is initiated if this bit is a logic '0'.

Upon the successful comparison of the device address byte, the 24CW Series will respond. If a valid comparison is not made, the device will not respond and return to a standby state.

3.3.2 WORD ADDRESS BYTES

Two 8-bit word address bytes are transmitted to the device immediately following the device address byte.

The first word address byte contains the Most Significant bits (MSBs) of the memory array word address to specify which location in the EEPROM to start reading or writing. Note that the number of word address bits depends on the density.

When accessing the memory array, it is required that bit 7 of the word address byte be set to a logic '0'. When accessing the Configuration registers, it is required that bit 7 of the first word address byte be set to a logic '1'. Refer to [Table 3-3](#) for details.

Next, the second word address byte is sent to the device which provides the remaining eight bits of the word address (A7 through A0). Refer to [Table 3-4](#) for details.

TABLE 3-3: FIRST WORD ADDRESS BYTE

Memory Region	Bit 7	Bit 6	Bit 5	Bit 4	Bit 3	Bit 2	Bit 1	Bit 0
16-Kbit EEPROM	0	x	x	x	x	A10	A9	A8
32-Kbit EEPROM	0	x	x	x	A11	A10	A9	A8
64-Kbit EEPROM	0	x	x	A12	A11	A10	A9	A8
Configuration Registers	1	x	x	x	x	x	x	x

TABLE 3-4: SECOND WORD ADDRESS BYTE

Memory Region	Bit 7	Bit 6	Bit 5	Bit 4	Bit 3	Bit 2	Bit 1	Bit 0
16-Kbit EEPROM	A7	A6	A5	A4	A3	A2	A1	A0
32-Kbit EEPROM	A7	A6	A5	A4	A3	A2	A1	A0
64-Kbit EEPROM	A7	A6	A5	A4	A3	A2	A1	A0
Configuration Registers ⁽¹⁾	x	x	x	x	x	x	x	x

- Note 1:** When accessing the Configuration registers, the second word address byte must be transmitted to the device despite containing only don't care values.

24CW16X/24CW32X/24CW64X

4.0 FUNCTIONAL DESCRIPTION

The 24CW Series supports a bidirectional 2-wire bus and data transmission protocol. A device that sends data onto the bus is defined as a transmitter and a device receiving data as a receiver. The bus must be controlled by a master which generates the Serial Clock (SCL), controls the bus access and generates the Start and Stop conditions, while the 24CW Series works as a slave. Both master and slave can operate as a transmitter or receiver, but the master determines which mode is activated.

5.0 BUS CHARACTERISTICS

The following bus protocol has been defined:

- Data transfer may be initiated only when the bus is not busy.
- During data transfer, the data line must remain stable whenever the clock line is high. Changes in the data line, while the clock line is high, will be interpreted as a Start or Stop condition.

Accordingly, the following bus conditions have been defined (Figure 5-1).

5.1 Bus Not Busy (A)

Both data and clock lines remain high.

5.2 Start Data Transfer (B)

A high-to-low transition of the SDA line while the clock (SCL) is high determines a Start condition. All commands must be preceded by a Start condition.

5.3 Stop Data Transfer (C)

A low-to-high transition of the SDA line while the clock (SCL) is high determines a Stop condition. All operations must end with a Stop condition.

5.4 Data Valid (D)

The state of the data line represents valid data when, after a Start condition, the data line is stable for the duration of the high period of the clock signal.

The data on the line must be changed during the low period of the clock signal. There is one bit of data per clock pulse.

Each data transfer is initiated with a Start condition and terminated with a Stop condition. The number of the data bytes transferred between the Start and Stop conditions is determined by the master.

5.5 Acknowledge

Each receiving device, when addressed, is obliged to generate an Acknowledge signal after the reception of each byte. The master must generate an extra clock pulse, which is associated with this Acknowledge bit. See Figure 5-2 for Acknowledge timing.

Note: The 24CW Series does not generate any Acknowledge bits if an internal programming cycle is in progress.

A device that Acknowledges must pull down the SDA line during the Acknowledge clock pulse, in such a way, that the SDA line is stable low during the high period of the Acknowledge related clock pulse. Of course, setup and hold times must be taken into account. During read operations, the master must signal an end of data to the slave by NOT generating an Acknowledge (NACK) bit on the last byte that has been clocked out of the slave. In this case, the slave (24CW Series) will leave the data line high to enable the master to generate the Stop condition.

FIGURE 5-1: DATA TRANSFER SEQUENCE ON THE SERIAL BUS



24CW16X/24CW32X/24CW64X

FIGURE 5-2: ACKNOWLEDGE TIMING



5.6 Standby Mode

The 24CW Series features a low-power Standby mode which is enabled when any one of the following occurs:

- A valid power-up sequence is performed (see [Section 1.1 “Power-up Requirements and Reset Behavior”](#)).
- A Stop condition is received by the device unless it initiates an internal write cycle (see [Section 6.0 “Write Operations”](#)).
- At the completion of an internal write cycle (see [Section 6.0 “Write Operations”](#)).
- An unsuccessful match of the Device Type Identifier or hardware slave address in the device address byte occurs (see [Section 3.3 “Device Addressing”](#)).
- The master does not Acknowledge the receipt of data read out from the device; instead, it sends a NACK response. (see [Section 7.0 “Read Operations”](#)).

5.7 Software Reset

After an interruption in protocol, power loss or system Reset, any 2-wire device can be protocol reset by clocking SCL until SDA is released by the EEPROM and goes high. The number of clock cycles until SDA is released by the EEPROM will vary. The Software Reset sequence should not take more than nine dummy clock cycles. Note that the Software Reset sequence will not interrupt the internal write cycle and only resets the I²C interface.

Once the Software Reset sequence is complete, new protocol can be sent to the device by sending a Start condition, followed by the protocol. [Figure 5-3](#) illustrates the Software Reset sequence.

In the event that the device is still non-responsive, or remains active on the SDA bus, a power cycle must be used to reset the device (see [Section 1.1.1 “Device Reset”](#)).

FIGURE 5-3: SOFTWARE RESET



24CW16X/24CW32X/24CW64X

6.0 WRITE OPERATIONS

All write operations for the 24CW Series begin with the master sending a Start condition, followed by a device address byte with the R/\overline{W} bit set to a logic '0', and then by the word address bytes. The data value(s) to be written to the device immediately follows the word address bytes.

6.1 Byte Write

The 24CW Series supports the writing of a single 8-bit byte. Selecting a data byte in the 24CW Series requires a two-byte word address with the MSb set to a logic '0'. Note that some word address bits are ignored and the number of ignored bits depends on the device density.

Upon receipt of the proper device address and word address bytes, the EEPROM will send an Acknowledge. The device will then be ready to receive the first 8-bit data byte. Following the receipt of the data byte, the EEPROM will respond with an Acknowledge. The addressing device, such as a master, must then terminate the write operation with a Stop condition. At that time, the EEPROM will enter an internally self-timed write cycle, which will be completed within t_{WC} , while the data byte is being programmed into the nonvolatile EEPROM. All inputs are disabled during this write cycle and the EEPROM will not respond until the write operation is complete.

If an attempt is made to write to a write-protected portion of the array, no data will be written and the device will immediately accept a new command.

FIGURE 6-1: BYTE WRITE



24CW16X/24CW32X/24CW64X

6.2 Page Write

A page write operation allows up to 32 bytes to be written in the same write cycle, provided all bytes are in the same page of the memory array. Partial page writes of less than 32 bytes are also allowed.

A page write is initiated the same way as a byte write, but the master does not send a Stop condition after the first data byte is clocked in. Instead, after the EEPROM Acknowledges receipt of the first data byte, the master can transmit up to 31 additional data bytes. The EEPROM will respond with an ACK after each data byte is received.

Once all data to be written has been sent to the device, the master must issue a Stop condition (see Figure 6-2). Once the Stop condition is received, an internal write cycle will begin.

If an attempt is made to write to a write-protected portion of the array, no data will be written and the device will immediately accept a new command.

The lower five bits of the word address are internally incremented following the receipt of each data byte. The higher order address bits are not incremented and retain the memory page location.

When the incremented word address reaches the page boundary, the address counter will roll over to the beginning of the same page.

Note: Page write operations are limited to writing bytes within a single physical page, **regardless** of the number of bytes actually being written. Physical page boundaries start at addresses that are integer multiples of the page buffer size (or 'page size') and end at the addresses that are integer multiples of [page size - 1]. If a page write operation attempts to write across a physical page boundary, the result is that the data wraps around to the beginning of the current page (overwriting data previously stored there), instead of being written to the next page as might be expected. It is therefore necessary for the application software to prevent page write operations that would attempt to cross a page boundary.

FIGURE 6-2: PAGE WRITE



24CW16X/24CW32X/24CW64X

6.3 Write Cycle Timing

The length of the self-timed write cycle, or t_{wc}, is defined as the amount of time from the Stop condition that begins the internal write operation, to the Start condition of the first device address byte sent to the 24CW Series that it subsequently responds to with an ACK (see Figure 6-3).

During the internally self-timed write cycle, any attempts to read from, or write to, the memory array will not be processed.

FIGURE 6-3: WRITE CYCLE TIMING



6.4 Acknowledge Polling

Since the device will not Acknowledge during a write cycle, this can be used to determine when the cycle is complete (this feature can be used to maximize bus throughput). Once the Stop condition for a write operation has been issued from the master, the device initiates the internally timed write cycle. ACK polling can be initiated immediately. This involves the master sending a Start condition, followed by the device address byte for a write operation ($R/\overline{W} = 0$). If the device is still busy with the write cycle, then a NACK will be returned. If a NACK is returned, then the Start bit and device address byte must be resent. If the cycle is complete, then the device will return the ACK and the master can then proceed with the next read or write operation. See Figure 6-4 for the flow diagram.

Note: If the user is polling after writing to the Hardware Address Register (HAR), the user must send the new hardware slave address to determine whether the write cycle is complete. If the 24CW Series doesn't ACK the new hardware slave address after the maximum write cycle time (twc), the write to the HAR was not successful.

FIGURE 6-4: ACKNOWLEDGE POLLING FLOW



24CW16X/24CW32X/24CW64X

6.5 Write Protection

The 24CW Series write protection is controlled via the Write Protection Register (WPR). The 24CW Series is segmented into four different memory zones, which allows the user to select which of the zones will be soft-

ware write-protected. The protection behavior can be made permanent by locking the Configuration registers. For additional information on the Write Protection Register, see [Section 8.2 “Write Protection Register”](#).

TABLE 6-1: 24CW SERIES SOFTWARE WRITE PROTECTION

Protection Level	Protected Address Range		
	24CW16X	24CW32X	24CW64X
None	None	None	None
Upper 1/4	0600h-07FFh	0C00h-0FFFh	1800h-1FFFh
Upper 1/2	0400h-07FFh	0800h-0FFFh	1000h-1FFFh
Upper 3/4	0200h-07FFh	0400h-0FFFh	0800h-1FFFh
Entire Array	0000h-07FFh	0000h-0FFFh	0000h-1FFFh

24CW16X/24CW32X/24CW64X

7.0 READ OPERATIONS

Read operations are initiated the same way as write operations, with the exception that the Read/Write Select (R/W) bit in the device address byte must be a logic '1'. There are three read operations:

- Current Address Read
- Random Address Read
- Sequential Read

7.1 Current Address Read

The 24CW Series contains an internal Address Pointer that maintains the word address of the last byte accessed, internally incremented by one. Therefore, if

the previous read access was to address 'n' (n is any legal address), the next current address read operation would access data from address n+1.

A current address read operation will output data according to the location of the internal Address Pointer. This is initiated with a Start condition, followed by a valid device address byte with the R/W bit set to logic '1'. The device will ACK this sequence and the current address data byte is serially clocked out on the SDA line. All types of read operations will be terminated if the master does not respond with an ACK (it NACKs) during the ninth clock cycle, which will force the device into Standby mode. After the NACK response, the master may send a Stop condition to complete the protocol or it can send a Start condition to begin the next sequence.

FIGURE 7-1: CURRENT ADDRESS READ

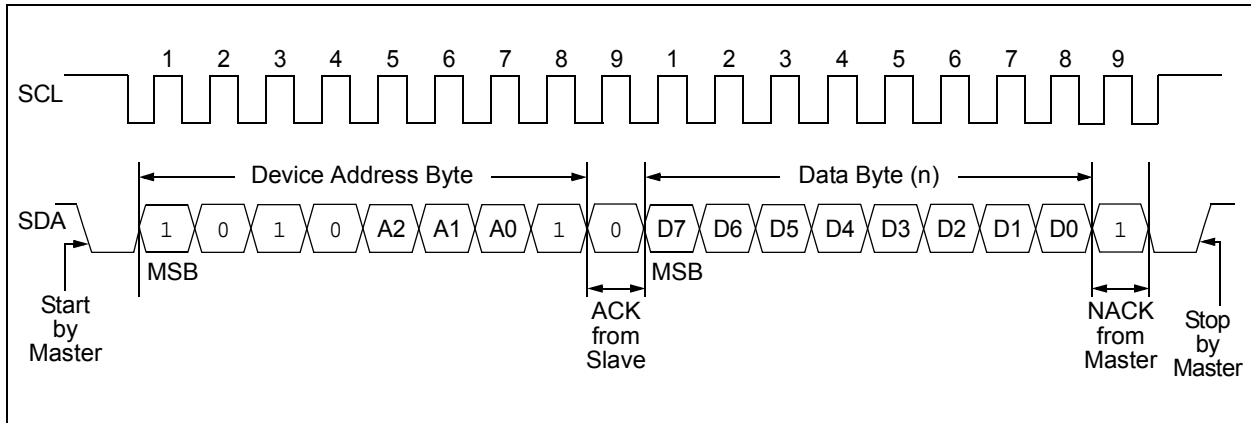

24CW16X/24CW32X/24CW64X

7.2 Random Read

Random read operations allow the master to access any memory location in a random manner. To perform this type of read operation, first the word address must be set. This is done by sending the word address, with the MSb set to logic '0', to the 24CW Series as part of a write operation (R/W bit set to '0'). After the word address is sent, the master generates a Start condition following the Acknowledge. This terminates the write operation, but not before the internal Address Pointer is

set. Then, the master issues the device address byte again, but with the R/W bit set to a '1'. The 24CW Series will then issue an Acknowledge and transmit the 8-bit data byte. The master will not Acknowledge the transfer, but does generate a Stop condition which causes the 24CW Series to discontinue transmission (Figure 7-2). After a random read operation, the internal Address Pointer will point to the last word address location, incremented by one.

FIGURE 7-2: RANDOM READ



24CW16X/24CW32X/24CW64X

7.3 Sequential Read

A sequential read is initiated by either a current address read or a random read. After the master receives a data byte, the master responds with an Acknowledge. As long as the EEPROM receives an ACK, it will continue to increment the word address and serially clock out the sequential data byte. When the maximum memory address is reached, the internal Address Pointer will automatically roll over from the

end of the array to word address, 0000h, if the master Acknowledges the byte received from the end of the array.

All types of read operations will be terminated if the master does not respond with an ACK (it NACKs) during the ninth clock cycle, which will force the device into Standby mode. After the NACK response, the master may send a Stop condition to complete the protocol or it can send a Start condition to begin the next sequence.

FIGURE 7-3: SEQUENTIAL READ



24CW16X/24CW32X/24CW64X

8.0 CONFIGURATION REGISTERS

The 24CW Series device contains a pair of 8-bit Configuration registers which control software write protection and the hardware slave address.

The Configuration registers are accessed sequentially as Byte 0 and Byte 1, as shown in [Table 8-1](#).

If desired, the Configuration registers can be locked so that the registers are set to read-only and can no longer be modified. This makes the current software write protection and hardware slave address scheme permanent.

TABLE 8-1: CONFIGURATION REGISTERS

Memory Region	Byte	Bit 7	Bit 6	Bit 5	Bit 4	Bit 3	Bit 2	Bit 1	Bit 0
Write Protection Register	0	—	WRTE	CCLK	—	WPRE	WPB <1:0>		CRLB
Hardware Address Register	1	—	CHRB	A0CK	—	—	A2	A1	A0

8.1 Accessing the Configuration Registers

The value of the Configuration registers can be determined by executing a random read sequence, as shown in [Section 8.5 “Reading the Configuration Registers”](#). Changing the value of the Configuration registers is accomplished with a byte write sequence with the requirements outlined in [Section 8.4 “Writing to the Configuration Registers”](#).

Accessing these registers requires the use of ‘1010b’ (Ah) as the Device Type Identifier in the device address byte. Following the Device Type Identifier is the hardware slave address bits for which the values are determined by what is currently programmed in the HAR (see [Section 8.3 “Hardware Address Register”](#)). Finally, bit 0 is the Read/Write Select (R/W) bit, where a logic ‘1’ is used for reading and logic ‘0’ is used for writing. See [Table 3-1](#) for additional information.

Note: The hardware slave address bit values are initially factory preset but can be changed by the user. These bit values must match the current device configuration to receive an Acknowledge.

When accessing the Configuration registers, the word address must be sent to the device. All bits in the word address are ignored, except for the MSb which must be set to logic ‘1’. Refer to [Table 3-3](#) and [Table 3-4](#) for additional information.

24CW16X/24CW32X/24CW64X

8.2 Write Protection Register

The Write Protection Register (WPR) is Byte 0 of the sequential Configuration registers. The Write Protection Register format can be seen in [Register 8-1](#).

REGISTER 8-1: WRITE PROTECTION REGISTER – BYTE 0

U-0	W-0	W-0	U-0	R/W	R/W	R/W	R/W
—	WRTE	CCLK	—	WPRE	WPB<1:0>		CRLB
bit 7				bit 0			

Legend:

R = Readable bit	W = Writable bit	U = Unimplemented bit, read as '0'
-n = Value at POR	'1' = Bit is set	'0' = Bit is cleared
		x = Bit is unknown

- bit 7 **Unimplemented:** Read as '0'
- bit 6 **WRTE:** Configuration Registers Write bit
1 = Configuration registers are writable
0 = Configuration register writes are ignored
- bit 5 **CCLK:** Configuration Registers Check Lock bit
Must match the CRLB bit when writing to the Configuration registers.
- bit 4 **Unimplemented:** Read as '0'
- bit 3 **WPRE:** Write Protection Register Enable bit
1 = Write protection is set by the WPB<1:0> bits
0 = No software write protection is enabled (**Default**)
- bit 2-1 **WPB<1:0>:** Write-Protect Block bits
If WPRE = 1:
11 = Entire EEPROM is write-protected
10 = Upper 3/4 of EEPROM is write-protected
01 = Upper 1/2 of EEPROM is write-protected
00 = Upper 1/4 of EEPROM is write-protected
If WPRE = 0:
Unused (**Default**).
- bit 0 **CRLB:** Configuration Registers Lock bit
1 = Configuration registers will become permanently locked
0 = Configuration registers can be written to (**Default**)

Configuration Registers Write bit (WRTE): This bit must be set to a logic '1' in order to write to the Configuration registers. Failure to set the WRTE bit to a logic '1' will cause the device to ignore the write operation. When reading the WPR, the WRTE bit will always read as logic '0'.

Configuration Registers Check Lock bit (CCLK): This bit must match the CRLB bit when writing the Configuration registers. If the CCLK bit does not match the CRLB, the device will ignore the write operation. When reading the WPR, the CCLK bit will always read as logic '0'.

Write Protection Register Enable bit (WPRE): This bit is used to enable or disable the device software write protection feature. A logic '0' will disable the software write protection feature and a logic '1' will enable software write protection.

Write-Protect Block bits (WPB<1:0>): These bits allow four levels of protection for the memory array, provided that the WPRE bit is set to a logic '1'. If the WPRE bit is a logic '0', the state of the WPB<1:0> bits has no impact on device protection. The protected address ranges can be found in [Table 8-2](#).

Configuration Registers Lock bit (CRLB): This bit is used to permanently lock the current state of the WPR and HAR. A logic '0' indicates that these registers can be modified, whereas a logic '1' indicates that the WPR and HAR have been locked and can no longer be modified. To safeguard against accidental locking of these registers, the CCLK bit must match the CRLB bit sent to the device. If these bits do not match, the device will ignore the write operation.

Note: The Configuration registers cannot be unlocked once they are locked.

24CW16X/24CW32X/24CW64X

8.2.1 SOFTWARE WRITE PROTECTION

The EEPROM array in the 24CW Series will be protected from writing in accordance with the WPB<1:0> bits value as long as the WPRE bit is set to logic '1'. If the WPRE bit is set to logic '0', the WPB<1:0> bits are

ignored and no portion of the EEPROM array will be protected. The combination of these three bits creates five possible levels of protection for the device, as seen in [Table 8-2](#).

TABLE 8-2: PROTECTED ADDRESS RANGE

Protection Level	WPRE	WPB1	WPB0	Protected Address Range		
				24CW16X	24CW32X	24CW64X
None	0	x	x	None	None	None
Upper 1/4	1	0	0	0600h-07FFh	0C00h-0FFFh	1800h-1FFFh
Upper 1/2	1	0	1	0400h-07FFh	0800h-0FFFh	1000h-1FFFh
Upper 3/4	1	1	0	0200h-07FFh	0400h-0FFFh	0800h-1FFFh
Entire Array	1	1	1	0000h-07FFh	0000h-0FFFh	0000h-1FFFh

24CW16X/24CW32X/24CW64X

8.3 Hardware Address Register

The Hardware Address Register (HAR) is Byte 1 of the sequential Configuration registers. The Hardware Address Register format can be seen in [Register 8-2](#).

REGISTER 8-2: HARDWARE ADDRESS REGISTER – BYTE 1

U-0	W-0	W-0	U-0	U-0	R/W	R/W	R/W
—	HWRE	A0CK	—	—	A2	A1	A0
bit 7							bit 0

Legend:

R = Readable bit
-n = Value at POR

W = Writable bit
'1' = Bit is set

U = Unimplemented bit, read as '0'
'0' = Bit is cleared

x = Bit is unknown

- bit 7 **Unimplemented:** Read as '0'
- bit 6 **HWRE:** HAR Write Enable bit
1 = Configuration registers are writable
0 = Configuration register writes are ignored
- bit 5 **A0CK:** Hardware Slave Address Check A0 bit
Must match A0 bit when writing the Configuration registers.
- bit 4-3 **Unimplemented:** Read as '0'
- bit 2 **A2:** Hardware Slave Address A2 bit
1 = Hardware slave address bit A2 is set to a logic '1'
0 = Hardware slave address bit A2 is set to a logic '0'
- bit 1 **A1:** Hardware Slave Address A1 bit
1 = Hardware slave address bit A1 is set to a logic '1'
0 = Hardware slave address bit A1 is set to a logic '0'
- bit 0 **A0:** Hardware Slave Address A0 bit
1 = Hardware slave address bit A0 is set to a logic '1'
0 = Hardware slave address bit A0 is set to a logic '0'

HAR Write Enable bit (HWRE): When writing to the HAR, this bit must be set to a logic '1'. Failure to set the HWRE bit to a logic '1' will cause the device to ignore the write operation. When reading the HAR, the HWRE bit will always read as logic '0'.

Hardware Slave Address Check A0 bit (A0CK): This bit must match the A0 bit when writing to the Configuration registers. If the A0CK bit does not match the A0 bit, the device will ignore the write operation. When reading the HAR, the A0CK bit will always read as logic '0'.

Hardware Slave Address bits (A2, A1, A0): The 3-bit hardware slave address is contained in bits A2, A1 and A0 of the HAR. These bits control the valid values in bit 3 through bit 1 (A2, A1, A0) of the device address byte. Details of the device address byte are found in [Section 3.3 "Device Addressing"](#).

Note: If multiple 24CW Series devices are on the same bus, each device must have unique hardware slave addresses to be accessed individually, including programming the HAR. Different preset hardware slave addresses are available. Contact your local sales representative for details.

24CW16X/24CW32X/24CW64X

8.4 Writing to the Configuration Registers

When writing to the Configuration registers, a byte write sequence must be sent to the device (see [Section 6.1 “Byte Write”](#) for additional information). The MSb of the word address must be set to logic ‘1’ in order to write to the Configuration registers.

A valid WPR byte must be provided when writing to the Configuration registers. If the WPR byte is invalid, the operation will abort, the EEPROM will not Acknowledge any data bytes and the device will not execute the internal write cycle. Refer to [Section 8.2 “Write Protection Register”](#) for valid WPR byte values.

After sending a valid WPR byte, the HAR byte can optionally be sent. If the HAR byte is invalid, the operation will abort, the EEPROM will not Acknowledge any data bytes and the device will not execute the internal write cycle. Refer to [Section 8.3 “Hardware Address Register”](#) for valid HAR byte values.

Sending more than the WPR and HAR bytes to the 24CW Series will cause the write cycle to abort and the contents of the WPR and HAR will not be changed.

Note: If a polling routine has been implemented and the user writes new data values to the HAR, the user must send the new hardware slave address for the device to Acknowledge.

FIGURE 8-1: CONFIGURATION REGISTERS WRITE SEQUENCE



24CW16X/24CW32X/24CW64X

8.5 Reading the Configuration Registers

When reading the Configuration registers, a random read sequence must be sent to the device (see [Section 7.2 “Random Read”](#) for additional information). The MSb of the word address must be set to logic ‘1’ in order to read the Configuration registers.

It is not possible to read the contents of the Configuration registers with a current address read sequence. Due to the sequential nature of the Configuration registers, it is not possible to read only the HAR contents.

Note: The 24CW Series will automatically roll over from the HAR (Byte 9) back to the WPR (Byte 0) if the master continues to Acknowledge the data bytes during the read operation.

FIGURE 8-2: CONFIGURATION REGISTERS READ SEQUENCE



24CW16X/24CW32X/24CW64X

8.6 Locking the Configuration Registers

The locking mechanism of the Configuration registers is controlled through the CLR_B bit found in the WPR byte.

When locking the Configuration registers, a byte write sequence must be sent to the device (see [Section 6.1 "Byte Write"](#) for additional information). The MS_B of the word address must be set to logic '1' in order to write to the Configuration registers.

Note: The Configuration registers cannot be unlocked once they are locked.

A valid WPR byte with the CCLK and CRLB bits set to a logic '1' must be provided when locking the Configuration registers. If the WPR byte is invalid, the operation will abort, the EEPROM will not Acknowledge any data bytes and the device will not execute the internal write cycle. Refer to [Section 8.2 "Write Protection Register"](#) for valid WPR byte values.

After sending a valid WPR byte, the HAR byte can optionally be sent. If the HAR byte is invalid, the operation will abort, the EEPROM will not Acknowledge any data bytes and the device will not execute the internal write cycle. Refer to [Section 8.3 "Hardware Address Register"](#) for valid HAR byte values.

It is possible to send only the WPR byte and lock the Configuration registers by omitting the HAR byte and sending a Stop condition after the WPR byte.

Note: If the HAR byte is omitted, the hardware slave address will be locked with its current values.

Sending more than the WPR and HAR bytes to the 24CW Series will cause the write cycle to abort and the contents of the WPR and HAR will not be changed.

FIGURE 8-3: CONFIGURATION REGISTER LOCK SEQUENCE



9.0 DEVICE DEFAULT CONDITION

The 24CW Series is delivered with the EEPROM array set to logic '1', resulting in FFh data in all locations of the EEPROM memory array.

The Write Protection Register (WPR) is set to 00h and the Hardware Address Register (HAR) is preset in accordance with the ordering code selected. For factory preset hardware slave address bits, other than '000b', contact your local sales representative.

24CW16X/24CW32X/24CW64X

10.0 PACKAGING INFORMATION

10.1 Package Marking Information

8-Lead 3.9 mm SOIC



Example



5-Lead SOT-23



Example



8-Lead 4.4 mm TSSOP



Example



Legend:	XX...X	Customer-specific information
	Y	Year code (last digit of calendar year)
	YY	Year code (last 2 digits of calendar year)
	WW	Week code (week of January 1 is week '01')
	NNN	Alphanumeric traceability code
	*	These packages are RoHs compliant. The JEDEC designator can be found on the outer packaging for this package.

Note: In the event the full Microchip part number cannot be marked on one line, it will be carried over to the next line, thus limiting the number of available characters for customer-specific information.

24CW16X/24CW32X/24CW64X

Package Marking Information (Continued)

8-Lead 2x3 mm UDFN



Example



4-Ball 0.4x0.4 mm CSP (CS0)



Example



4-Ball 0.5x0.4 mm CSP (CS1)



Example



Part Number	1st Line Marking Codes					
	SOIC	SOT-23	TSSOP	UDFN	CSP (CS0) ⁽¹⁾	CSP (CS1) ⁽²⁾
24CW16 Series	24CW160	AAEN	AADJ	ADG	—	—
24CW32 Series	24CW320	AAEP	AADK	ADH	—	—
24CW64 Series	24CW640	AAEQ	AADL	ADJ	● 6	6 ●

Note 1: CS0 CSP ball pitch is 0.4x0.4mm.

Note 2: CS1 CSP ball pitch is 0.5x0.4mm.

24CW16X/24CW32X/24CW64X

8-Lead Plastic Small Outline (SN) - Narrow, 3.90 mm Body [SOIC]

Note: For the most current package drawings, please see the Microchip Packaging Specification located at <http://www.microchip.com/packaging>



Microchip Technology Drawing No. C04-057C Sheet 1 of 2

24CW16X/24CW32X/24CW64X

8-Lead Plastic Small Outline (SN) - Narrow, 3.90 mm Body [SOIC]

Note: For the most current package drawings, please see the Microchip Packaging Specification located at <http://www.microchip.com/packaging>



Dimension Limits	Units	MILLIMETERS		
		MIN	NOM	MAX
Number of Pins	N	8		
Pitch	e	1.27 BSC		
Overall Height	A	-	-	1.75
Molded Package Thickness	A2	1.25	-	-
Standoff §	A1	0.10	-	0.25
Overall Width	E	6.00 BSC		
Molded Package Width	E1	3.90 BSC		
Overall Length	D	4.90 BSC		
Chamfer (Optional)	h	0.25	-	0.50
Foot Length	L	0.40	-	1.27
Footprint	L1	1.04 REF		
Foot Angle	φ	0°	-	8°
Lead Thickness	c	0.17	-	0.25
Lead Width	b	0.31	-	0.51
Mold Draft Angle Top	α	5°	-	15°
Mold Draft Angle Bottom	β	5°	-	15°

Notes:

1. Pin 1 visual index feature may vary, but must be located within the hatched area.
2. § Significant Characteristic
3. Dimensions D and E1 do not include mold flash or protrusions. Mold flash or protrusions shall not exceed 0.15mm per side.
4. Dimensioning and tolerancing per ASME Y14.5M

BSC: Basic Dimension. Theoretically exact value shown without tolerances.

REF: Reference Dimension, usually without tolerance, for information purposes only.

Microchip Technology Drawing No. C04-057C Sheet 2 of 2

24CW16X/24CW32X/24CW64X

8-Lead Plastic Small Outline (SN) – Narrow, 3.90 mm Body [SOIC]

Note: For the most current package drawings, please see the Microchip Packaging Specification located at <http://www.microchip.com/packaging>



RECOMMENDED LAND PATTERN

Dimension Limits	Units	MILLIMETERS		
		MIN	NOM	MAX
Contact Pitch	E	1.27 BSC		
Contact Pad Spacing	C		5.40	
Contact Pad Width (X8)	X1			0.60
Contact Pad Length (X8)	Y1			1.55

Notes:

1. Dimensioning and tolerancing per ASME Y14.5M

BSC: Basic Dimension. Theoretically exact value shown without tolerances.

Microchip Technology Drawing No. C04-2057A

24CW16X/24CW32X/24CW64X

5-Lead Plastic Small Outline Transistor (OT) [SOT23]

Note: For the most current package drawings, please see the Microchip Packaging Specification located at <http://www.microchip.com/packaging>



Microchip Technology Drawing C04-028D [OT] Sheet 1 of 2

24CW16X/24CW32X/24CW64X

5-Lead Plastic Small Outline Transistor (OT) [SOT23]

Note: For the most current package drawings, please see the Microchip Packaging Specification located at <http://www.microchip.com/packaging>



VIEW A-A
SHEET 1

Dimension Limits	Units	MILLIMETERS		
		MIN	NOM	MAX
Number of Pins	N	6		
Pitch	e	0.95 BSC		
Outside lead pitch	e1	1.90 BSC		
Overall Height	A	0.90	-	1.45
Molded Package Thickness	A2	0.89	-	1.30
Standoff	A1	-	-	0.15
Overall Width	E	2.80 BSC		
Molded Package Width	E1	1.60 BSC		
Overall Length	D	2.90 BSC		
Foot Length	L	0.30	-	0.60
Footprint	L1	0.60 REF		
Foot Angle	φ	0°	-	10°
Lead Thickness	c	0.08	-	0.26
Lead Width	b	0.20	-	0.51

Notes:

- Dimensions D and E1 do not include mold flash or protrusions. Mold flash or protrusions shall not exceed 0.25mm per side.
- Dimensioning and tolerancing per ASME Y14.5M
BSC: Basic Dimension. Theoretically exact value shown without tolerances.
REF: Reference Dimension, usually without tolerance, for information purposes only.

Microchip Technology Drawing C04-091D [OT] Sheet 2 of 2

24CW16X/24CW32X/24CW64X

5-Lead Plastic Small Outline Transistor (OT) [SOT23]

Note: For the most current package drawings, please see the Microchip Packaging Specification located at <http://www.microchip.com/packaging>



RECOMMENDED LAND PATTERN

Dimension Limits	Units	MILLIMETERS		
		MIN	NOM	MAX
Contact Pitch	E	0.95 BSC		
Contact Pad Spacing	C		2.80	
Contact Pad Width (X5)	X			0.60
Contact Pad Length (X5)	Y			1.10
Distance Between Pads	G	1.70		
Distance Between Pads	GX	0.35		
Overall Width	Z			3.90

Notes:

1. Dimensioning and tolerancing per ASME Y14.5M

BSC: Basic Dimension. Theoretically exact value shown without tolerances.

Microchip Technology Drawing No. C04-2091A [OT]

24CW16X/24CW32X/24CW64X

8-Lead Plastic Thin Shrink Small Outline (ST) – 4.4 mm Body [TSSOP]

Note: For the most current package drawings, please see the Microchip Packaging Specification located at <http://www.microchip.com/packaging>

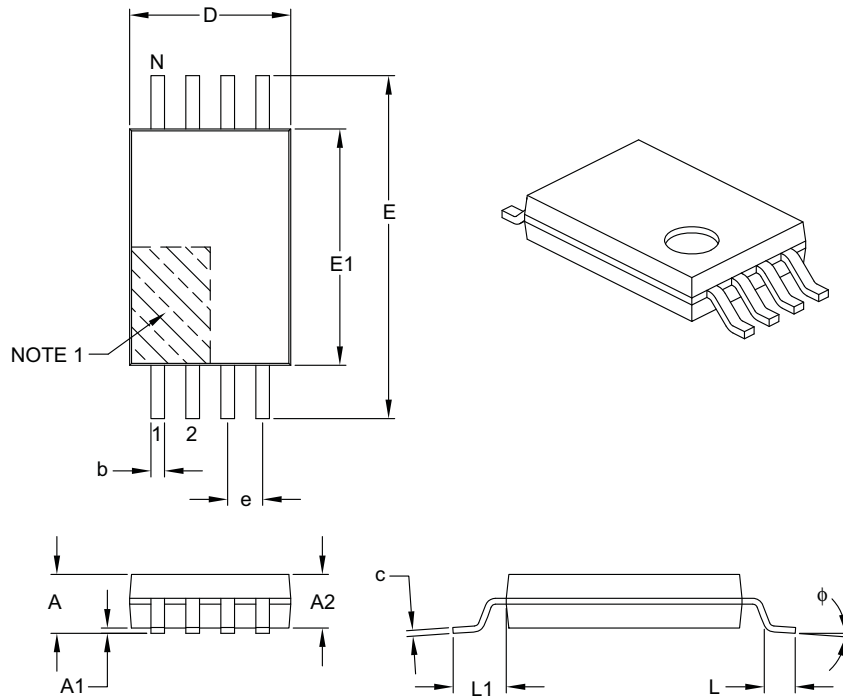

Dimension Limits	Units	MILLIMETERS		
		MIN	NOM	MAX
Number of Pins	N	8		
Pitch	e	0.65 BSC		
Overall Height	A	–	–	1.20
Molded Package Thickness	A2	0.80	1.00	1.05
Standoff	A1	0.05	–	0.15
Overall Width	E	6.40 BSC		
Molded Package Width	E1	4.30	4.40	4.50
Molded Package Length	D	2.90	3.00	3.10
Foot Length	L	0.45	0.60	0.75
Footprint	L1	1.00 REF		
Foot Angle	ϕ	0°	–	8°
Lead Thickness	c	0.09	–	0.20
Lead Width	b	0.19	–	0.30

Notes:

- Pin 1 visual index feature may vary, but must be located within the hatched area.
- Dimensions D and E1 do not include mold flash or protrusions. Mold flash or protrusions shall not exceed 0.15 mm per side.
- Dimensioning and tolerancing per ASME Y14.5M.

BSC: Basic Dimension. Theoretically exact value shown without tolerances.

REF: Reference Dimension, usually without tolerance, for information purposes only.

Microchip Technology Drawing C04-086B

24CW16X/24CW32X/24CW64X

8-Lead Plastic Thin Shrink Small Outline (ST) - 4.4 mm Body [TSSOP]

Note: For the most current package drawings, please see the Microchip Packaging Specification located at <http://www.microchip.com/packaging>



RECOMMENDED LAND PATTERN

		Units	MILLIMETERS		
Dimension Limits			MIN	NOM	MAX
Contact Pitch	E		0.65 BSC		
Contact Pad Spacing	C1			5.90	
Contact Pad Width (X8)	X1				0.45
Contact Pad Length (X8)	Y1				1.45
Distance Between Pads	G	0.20			

Notes:

1. Dimensioning and tolerancing per ASME Y14.5M

BSC: Basic Dimension. Theoretically exact value shown without tolerances.

Microchip Technology Drawing No. C04-2086A

24CW16X/24CW32X/24CW64X

8-Lead Plastic Dual Flat, No Lead Package (MU) – 2x3x0.5 mm Body [UDFN]

Note: For the most current package drawings, please see the Microchip Packaging Specification located at <http://www.microchip.com/packaging>



Dimension	Units	MILLIMETERS		
		MIN	NOM	MAX
Number of Pins	N	8		
Pitch	e	0.50 BSC		
Overall Height	A	0.45	0.50	0.55
Standoff	A1			0.07
Contact Thickness	A3	0.127 REF		
Overall Length	D	1.95	2.00	2.05
Overall Width	E	2.95	3.00	3.05
Exposed Pad Length	D2	1.30	1.40	1.50
Exposed Pad Width	E2	1.20	1.30	1.40
Contact Width	b	0.20	0.25	0.30
Contact Length	L	0.25	0.30	0.35
Contact-to-Exposed Pad	K	0.55 REF		

Notes:

1. Pin 1 visual index feature may vary, but must be located within the hatched area.
2. Package may have one or more exposed tie bars at ends.
3. Package is saw singulated
4. Dimensioning and tolerancing per ASME Y14.5M

BSC: Basic Dimension. Theoretically exact value shown without tolerances.

REF: Reference Dimension, usually without tolerance, for information purposes only.

Microchip Technology Drawing No. C04-136B

24CW16X/24CW32X/24CW64X

8-Lead Plastic Dual Flat, No Lead Package (MU) – 2x3x0.5 mm Body [UDFN]

Note: For the most current package drawings, please see the Microchip Packaging Specification located at <http://www.microchip.com/packaging>



Dimension Limits	Units	MILLIMETERS		
		MIN	NOM	MAX
Contact Pitch	E	0.50 BSC		
Optional Center Pad Width	W2			1.46
Optional Center Pad Length	T2			1.36
Contact Pad Spacing	C1		3.00	
Contact Pad Width (X8)	X1			0.30
Contact Pad Length (X8)	Y1			0.75
Distance Between Pads	G	0.20		

Notes:

1. Dimensioning and tolerancing per ASME Y14.5M

BSC: Basic Dimension. Theoretically exact value shown without tolerances.

Microchip Technology Drawing No. C04-2136A

24CW16X/24CW32X/24CW64X

4-Ball Wafer Level Chip Scale Package (CS) - 0.4x0.4 mm Ball Pitch [CSP]

Note: For the most current package drawings, please see the Microchip Packaging Specification located at <http://www.microchip.com/packaging>

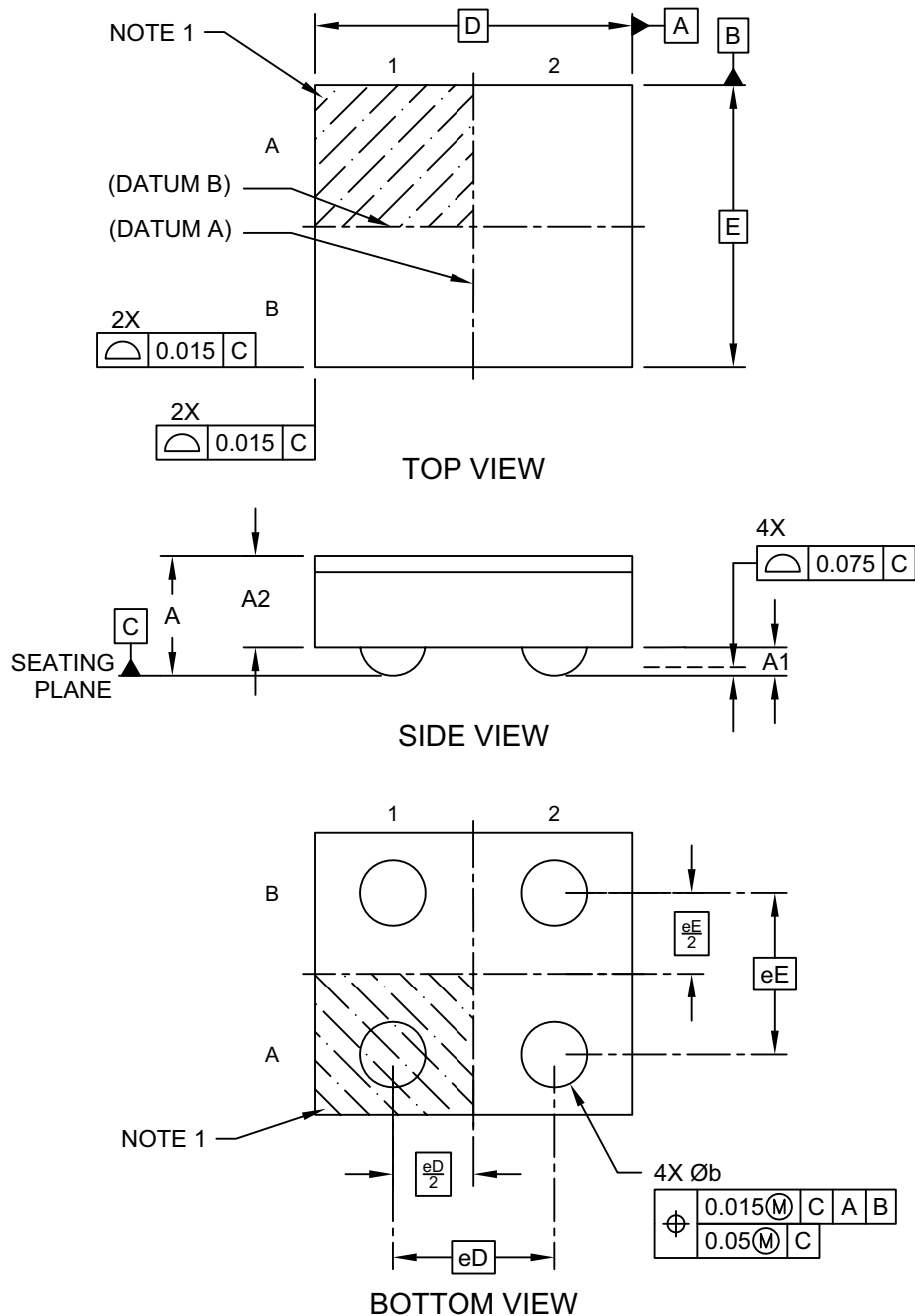

Microchip Technology Drawing C04-6047 Rev. A Sheet 1 of 2

24CW16X/24CW32X/24CW64X

4-Ball Wafer Level Chip Scale Package (CS) - 0.4x0.4 mm Ball Pitch [CSP]

Note: For the most current package drawings, please see the Microchip Packaging Specification located at <http://www.microchip.com/packaging>

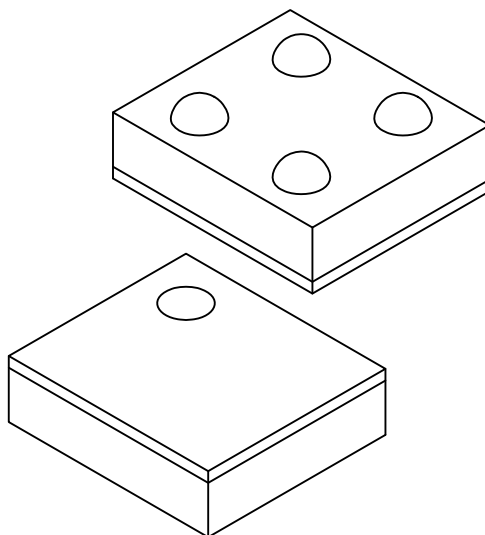

Dimension Limits	Units	MILLIMETERS		
		MIN	NOM	MAX
Number of Terminals	N	4		
Bump Pitch	eD	0.40 BSC		
Bump Pitch	eE	0.40 BSC		
Overall Height	A	0.260	0.295	0.330
Standoff	A1	-	0.070	-
Die Height	A2	-	0.225	-
Overall Length	D	Contact Microchip for details		
Overall Width	E	Contact Microchip for details		
Terminal Width	b	0.260	0.300	0.340

Notes:

1. Pin 1 visual index feature may vary, but must be located within the hatched area.
2. Dimensioning and tolerancing per ASME Y14.5M

BSC: Basic Dimension. Theoretically exact value shown without tolerances.

REF: Reference Dimension, usually without tolerance, for information purposes only.

Microchip Technology Drawing C04-6047 Rev. A Sheet 2 of 2

24CW16X/24CW32X/24CW64X

4-Ball Wafer Level Chip Scale Package (CS) - 0.4x0.4 mm Ball Pitch [CSP]

Note: For the most current package drawings, please see the Microchip Packaging Specification located at <http://www.microchip.com/packaging>



RECOMMENDED LAND PATTERN

Dimension Limits	Units	MILLIMETERS		
		MIN	NOM	MAX
Contact Pitch	eD		0.40 BSC	
Contact Pitch	eE		0.40 BSC	
Contact Diameter	ØX1		0.30	

Notes:

- Dimensioning and tolerancing per ASME Y14.5M
BSC: Basic Dimension. Theoretically exact value shown without tolerances.
- For best soldering results, thermal vias, if used, should be filled or tented to avoid solder loss during reflow process

Microchip Technology Drawing C04-8047 Rev. A

24CW16X/24CW32X/24CW64X

4-Ball Wafer Level Chip Scale Package (CS) - 0.4x0.5 mm Ball Pitch [CSP]

Note: For the most current package drawings, please see the Microchip Packaging Specification located at <http://www.microchip.com/packaging>



Microchip Technology Drawing C04-6048 Rev. A Sheet 1 of 2

24CW16X/24CW32X/24CW64X

4-Ball Wafer Level Chip Scale Package (CS) - 0.4x0.5 mm Ball Pitch [CSP]

Note: For the most current package drawings, please see the Microchip Packaging Specification located at <http://www.microchip.com/packaging>



Dimension Limits	Units	MILLIMETERS		
		MIN	NOM	MAX
Number of Terminals	N	4		
Bump Pitch	eD	0.40 BSC		
Bump Pitch	eE		0.50 BSC	
Overall Height	A	0.260	0.295	0.330
Standoff	A1	-	0.070	-
Die Height	A2	-	0.225	-
Overall Length	D	Contact Microchip for details		
Overall Width	E	Contact Microchip for details		
Terminal Width	b	0.260	0.300	0.340

Notes:

1. Pin 1 visual index feature may vary, but must be located within the hatched area.
2. Dimensioning and tolerancing per ASME Y14.5M

BSC: Basic Dimension. Theoretically exact value shown without tolerances.

REF: Reference Dimension, usually without tolerance, for information purposes only.

Microchip Technology Drawing C04-6048 Rev. A Sheet 2 of 2

24CW16X/24CW32X/24CW64X

4-Ball Wafer Level Chip Scale Package (CS) - 0.4x0.5 mm Ball Pitch [CSP]

Note: For the most current package drawings, please see the Microchip Packaging Specification located at <http://www.microchip.com/packaging>



RECOMMENDED LAND PATTERN

Dimension Limits	Units	MILLIMETERS		
		MIN	NOM	MAX
Contact Pitch	eD		0.40 BSC	
Contact Pitch	eE		0.50 BSC	
Contact Diameter	ØX1		0.30	

Notes:

- Dimensioning and tolerancing per ASME Y14.5M
BSC: Basic Dimension. Theoretically exact value shown without tolerances.
- For best soldering results, thermal vias, if used, should be filled or tented to avoid solder loss during reflow process

Microchip Technology Drawing C04-8048 Rev. A

24CW16X/24CW32X/24CW64X

APPENDIX A: REVISION HISTORY

Revision A (10/2017)

Initial release of this document.

THE MICROCHIP WEBSITE

Microchip provides online support via our website at www.microchip.com. This website is used as a means to make files and information easily available to customers. Accessible by using your favorite Internet browser, the website contains the following information:

- **Product Support** – Data sheets and errata, application notes and sample programs, design resources, user's guides and hardware support documents, latest software releases and archived software
- **General Technical Support** – Frequently Asked Questions (FAQ), technical support requests, online discussion groups, Microchip consultant program member listing
- **Business of Microchip** – Product selector and ordering guides, latest Microchip press releases, listing of seminars and events, listings of Microchip sales offices, distributors and factory representatives

CUSTOMER CHANGE NOTIFICATION SERVICE

Microchip's customer notification service helps keep customers current on Microchip products. Subscribers will receive e-mail notification whenever there are changes, updates, revisions or errata related to a specified product family or development tool of interest.

To register, access the Microchip website at www.microchip.com. Under "Support", click on "Customer Change Notification" and follow the registration instructions.

CUSTOMER SUPPORT

Users of Microchip products can receive assistance through several channels:

- Distributor or Representative
- Local Sales Office
- Field Application Engineer (FAE)
- Technical Support

Customers should contact their distributor, representative or Field Application Engineer (FAE) for support. Local sales offices are also available to help customers. A listing of sales offices and locations is included in the back of this document.

Technical support is available through the website at: <http://microchip.com/support>

24CW16X/24CW32X/24CW64X

NOTES:

PRODUCT IDENTIFICATION SYSTEM

To order or obtain information, e.g., on pricing or delivery, refer to the factory or the listed sales office.

<u>PART NO.</u>	<u>X⁽¹⁾</u>	<u>IXI⁽¹⁾</u>	<u>X</u>	<u>/XX</u>	Examples:
Device	Slave Address	Tape and Reel Option	Temperature Range	Package	
Device:	24CW16X	=	16-Kbit I ² C Compatible Serial EEPROM with Software Write Protection		a) 24CW160-I/SN = 16-Kbit, Slave Address 0, Industrial Temp., SOIC Package.
	24CW32X	=	32-Kbit I ² C Compatible Serial EEPROM with Software Write Protection		b) 24CW320T-I/SN = 32-Kbit, Slave Address 0, Tape and Reel, Industrial Temp., SOIC Package.
	24CW64X	=	64-Kbit I ² C Compatible Serial EEPROM with Software Write Protection		c) 24CW640-I/SN = 64-Kbit, Slave Address 0, Industrial Temp., SOIC Package.
Slave Address:⁽¹⁾	0	=	Hardware Slave Address '000b'		d) 24CW320-I/ST = 32-Kbit, Slave Address 0, Industrial Temp., TSSOP Package.
	1	=	Hardware Slave Address '001b'		e) 24CW640T-I/ST = 64-Kbit, Slave Address 0, Tape and Reel, Industrial Temp., TSSOP Package.
	2	=	Hardware Slave Address '010b'		f) 24CW160T-I/OT = 16-Kbit, Slave Address 0, Tape and Reel, Industrial Temp., SOT-23 Package.
	3	=	Hardware Slave Address '011b'		g) 24CW320T-I/OT = 32-Kbit, Slave Address 0, Tape and Reel, Industrial Temp., SOT-23 Package.
	4	=	Hardware Slave Address '100b'		h) 24CW320T-I/MU = 32-Kbit, Slave Address 0, Tape and Reel, Industrial Temp., UDFN Package.
	5	=	Hardware Slave Address '101b'		i) 24CW640T-I/MU = 64-Kbit, Slave Address 0, Tape and Reel, Industrial Temp., UDFN Package.
	6	=	Hardware Slave Address '110b'		j) 24CW640T-I/CS0668 = 64-Kbit, Slave Address 0, Tape and Reel, Industrial Temp., CS0 Package.
	7	=	Hardware Slave Address '111b'		k) 24CW640T-I/CS1668 = 64-Kbit, Slave Address 0, Tape and Reel, Industrial Temp., CS1 Package.
Tape and Reel Option:	Blank	=	Standard Packaging (tube or tray)		
	T	=	Tape and Reel ⁽¹⁾		
Temperature Range:	I	=	-40°C to +85°C (Industrial)		
Package:	SN	=	8-Lead Plastic Small Outline – Narrow, 3.90 mm Body		
	OT	=	5-Lead Plastic Small Outline Transistor		
	ST	=	8-Lead Plastic Thin Shrink Small Outline – 4.4 mm Body		
	MU	=	8-Lead Plastic Dual Flat, No Lead Package – 2x3x0.5 mm		
	CS0668	=	4-Ball Extremely Thin Fine Pitch Wafer Level Chip Scale Package – 0.4x0.4 mm Pitch		
	CS1668	=	4-Ball Extremely Thin Fine Pitch Wafer Level Chip Scale Package – 0.5x0.4 mm Pitch		
					Note 1: Slave Address and Tape and Reel identifiers only appear in the catalog part number description. These identifiers are used for ordering purposes and are not printed on the device package. Check with your Microchip Sales Office for availability.

24CW SERIES

NOTES:

Note the following details of the code protection feature on Microchip devices:

- Microchip products meet the specification contained in their particular Microchip Data Sheet.
- Microchip believes that its family of products is one of the most secure families of its kind on the market today, when used in the intended manner and under normal conditions.
- There are dishonest and possibly illegal methods used to breach the code protection feature. All of these methods, to our knowledge, require using the Microchip products in a manner outside the operating specifications contained in Microchip's Data Sheets. Most likely, the person doing so is engaged in theft of intellectual property.
- Microchip is willing to work with the customer who is concerned about the integrity of their code.
- Neither Microchip nor any other semiconductor manufacturer can guarantee the security of their code. Code protection does not mean that we are guaranteeing the product as “unbreakable.”

Code protection is constantly evolving. We at Microchip are committed to continuously improving the code protection features of our products. Attempts to break Microchip's code protection feature may be a violation of the Digital Millennium Copyright Act. If such acts allow unauthorized access to your software or other copyrighted work, you may have a right to sue for relief under that Act.

Information contained in this publication regarding device applications and the like is provided only for your convenience and may be superseded by updates. It is your responsibility to ensure that your application meets with your specifications. MICROCHIP MAKES NO REPRESENTATIONS OR WARRANTIES OF ANY KIND WHETHER EXPRESS OR IMPLIED, WRITTEN OR ORAL, STATUTORY OR OTHERWISE, RELATED TO THE INFORMATION, INCLUDING BUT NOT LIMITED TO ITS CONDITION, QUALITY, PERFORMANCE, MERCHANTABILITY OR FITNESS FOR PURPOSE. Microchip disclaims all liability arising from this information and its use. Use of Microchip devices in life support and/or safety applications is entirely at the buyer's risk, and the buyer agrees to defend, indemnify and hold harmless Microchip from any and all damages, claims, suits, or expenses resulting from such use. No licenses are conveyed, implicitly or otherwise, under any Microchip intellectual property rights unless otherwise stated.

Microchip received ISO/TS-16949:2009 certification for its worldwide headquarters, design and wafer fabrication facilities in Chandler and Tempe, Arizona; Gresham, Oregon and design centers in California and India. The Company's quality system processes and procedures are for its PIC® MCUs and dsPIC® DSCs, KEELoQ® code hopping devices, Serial EEPROMs, microperipherals, nonvolatile memory and analog products. In addition, Microchip's quality system for the design and manufacture of development systems is ISO 9001:2000 certified.

**QUALITY MANAGEMENT SYSTEM
CERTIFIED BY DNV
= ISO/TS 16949 =**

Trademarks

The Microchip name and logo, the Microchip logo, AnyRate, AVR, AVR logo, AVR Freaks, BeaconThings, BitCloud, chipKIT, chipKIT logo, CryptoMemory, CryptoRF, dsPIC, FlashFlex, flexPWR, Helder, JukeBlox, KEELoQ, KEELoQ logo, Kleer, LANCheck, LINK MD, maXStylus, maXTouch, MedialB, megaAVR, MOST, MOST logo, MPLAB, OptoLyzer, PIC, picoPower, PICSTART, PIC32 logo, Prochip Designer, QTouch, RightTouch, SAM-BA, SpyNIC, SST, SST Logo, SuperFlash, tinyAVR, UNI/O, and XMEGA are registered trademarks of Microchip Technology Incorporated in the U.S.A. and other countries.

ClockWorks, The Embedded Control Solutions Company, EtherSynch, Hyper Speed Control, HyperLight Load, IntelliMOS, mTouch, Precision Edge, and Quiet-Wire are registered trademarks of Microchip Technology Incorporated in the U.S.A.

Adjacent Key Suppression, AKS, Analog-for-the-Digital Age, Any Capacitor, AnyIn, AnyOut, BodyCom, CodeGuard, CryptoAuthentication, CryptoCompanion, CryptoController, dsPICDEM, dsPICDEM.net, Dynamic Average Matching, DAM, ECAN, EtherGREEN, In-Circuit Serial Programming, ICSP, Inter-Chip Connectivity, JitterBlocker, KleerNet, KleerNet logo, Mindi, MiWi, motorBench, MPASM, MPF, MPLAB Certified logo, MPLIB, MPLINK, MultiTRAK, NetDetach, Omniscient Code Generation, PICDEM, PICDEM.net, PICKit, PICTail, PureSilicon, QMatrix, RightTouch logo, REAL ICE, Ripple Blocker, SAM-ICE, Serial Quad I/O, SMART-I.S., SQI, SuperSwitcher, SuperSwitcher II, Total Endurance, TSHARC, USBCheck, VariSense, ViewSpan, WiperLock, Wireless DNA, and ZENA are trademarks of Microchip Technology Incorporated in the U.S.A. and other countries.

SQTP is a service mark of Microchip Technology Incorporated in the U.S.A.

Silicon Storage Technology is a registered trademark of Microchip Technology Inc. in other countries.

GestIC is a registered trademark of Microchip Technology Germany II GmbH & Co. KG, a subsidiary of Microchip Technology Inc., in other countries.

All other trademarks mentioned herein are property of their respective companies.

© 2017, Microchip Technology Incorporated, All Rights Reserved.

ISBN: 978-1-5224-2214-3



MICROCHIP

Worldwide Sales and Service

AMERICAS

Corporate Office
2355 West Chandler Blvd.
Chandler, AZ 85224-6199
Tel: 480-792-7200
Fax: 480-792-7277
Technical Support:
<http://www.microchip.com/support>
Web Address:
www.microchip.com

Atlanta
Duluth, GA
Tel: 678-957-9614
Fax: 678-957-1455

Austin, TX
Tel: 512-257-3370

Boston
Westborough, MA
Tel: 774-760-0087
Fax: 774-760-0088

Chicago
Itasca, IL
Tel: 630-285-0071
Fax: 630-285-0075

Dallas
Addison, TX
Tel: 972-818-7423
Fax: 972-818-2924

Detroit
Novi, MI
Tel: 248-848-4000

Houston, TX
Tel: 281-894-5983

Indianapolis
Noblesville, IN
Tel: 317-773-8323
Fax: 317-773-5453
Tel: 317-536-2380

Los Angeles
Mission Viejo, CA
Tel: 949-462-9523
Fax: 949-462-9608
Tel: 951-273-7800

Raleigh, NC
Tel: 919-844-7510

New York, NY
Tel: 631-435-6000

San Jose, CA
Tel: 408-735-9110
Tel: 408-436-4270

Canada - Toronto
Tel: 905-695-1980
Fax: 905-695-2078

ASIA/PACIFIC

Asia Pacific Office
Suites 3707-14, 37th Floor
Tower 6, The Gateway
Harbour City, Kowloon

Hong Kong
Tel: 852-2943-5100
Fax: 852-2401-3431

Australia - Sydney
Tel: 61-2-9868-6733
Fax: 61-2-9868-6755

China - Beijing
Tel: 86-10-8569-7000
Fax: 86-10-8528-2104

China - Chengdu
Tel: 86-28-8665-5511
Fax: 86-28-8665-7889

China - Chongqing
Tel: 86-23-8980-9588
Fax: 86-23-8980-9500

China - Dongguan
Tel: 86-769-8702-9880

China - Guangzhou
Tel: 86-20-8755-8029

China - Hangzhou
Tel: 86-571-8792-8115
Fax: 86-571-8792-8116

China - Hong Kong SAR
Tel: 852-2943-5100
Fax: 852-2401-3431

China - Nanjing
Tel: 86-25-8473-2460
Fax: 86-25-8473-2470

China - Qingdao
Tel: 86-532-8502-7355
Fax: 86-532-8502-7205

China - Shanghai
Tel: 86-21-3326-8000
Fax: 86-21-3326-8021

China - Shenyang
Tel: 86-24-2334-2829
Fax: 86-24-2334-2393

China - Shenzhen
Tel: 86-755-8864-2200
Fax: 86-755-8203-1760

China - Wuhan
Tel: 86-27-5980-5300
Fax: 86-27-5980-5118

China - Xian
Tel: 86-29-8833-7252
Fax: 86-29-8833-7256

ASIA/PACIFIC

China - Xiamen
Tel: 86-592-2388138
Fax: 86-592-2388130

China - Zhuhai
Tel: 86-756-3210040
Fax: 86-756-3210049

India - Bangalore
Tel: 91-80-3090-4444
Fax: 91-80-3090-4123

India - New Delhi
Tel: 91-11-4160-8631
Fax: 91-11-4160-8632

India - Pune
Tel: 91-20-3019-1500

Japan - Osaka
Tel: 81-6-6152-7160
Fax: 81-6-6152-9310

Japan - Tokyo
Tel: 81-3-6880-3770
Fax: 81-3-6880-3771

Korea - Daegu
Tel: 82-53-744-4301
Fax: 82-53-744-4302

Korea - Seoul
Tel: 82-2-554-7200
Fax: 82-2-558-5932 or
82-2-558-5934

Malaysia - Kuala Lumpur
Tel: 60-3-6201-9857
Fax: 60-3-6201-9859

Malaysia - Penang
Tel: 60-4-227-8870
Fax: 60-4-227-4068

Philippines - Manila
Tel: 63-2-634-9065
Fax: 63-2-634-9069

Singapore
Tel: 65-6334-8870
Fax: 65-6334-8850

Taiwan - Hsin Chu
Tel: 886-3-5778-366
Fax: 886-3-5770-955

Taiwan - Kaohsiung
Tel: 886-7-213-7830

Taiwan - Taipei
Tel: 886-2-2508-8600
Fax: 886-2-2508-0102

Thailand - Bangkok
Tel: 66-2-694-1351
Fax: 66-2-694-1350

EUROPE

Austria - Wels
Tel: 43-7242-2244-39
Fax: 43-7242-2244-393

Denmark - Copenhagen
Tel: 45-4450-2828
Fax: 45-4485-2829

Finland - Espoo
Tel: 358-9-4520-820

France - Paris
Tel: 33-1-69-53-63-20
Fax: 33-1-69-30-90-79

France - Saint Cloud
Tel: 33-1-30-60-70-00

Germany - Garching
Tel: 49-8931-9700

Germany - Haan
Tel: 49-2129-3766400

Germany - Heilbronn
Tel: 49-7131-67-3636

Germany - Karlsruhe
Tel: 49-721-625370

Germany - Munich
Tel: 49-89-627-144-0
Fax: 49-89-627-144-44

Germany - Rosenheim
Tel: 49-8031-354-560

Israel - Ra'anana
Tel: 972-9-744-7705

Italy - Milan
Tel: 39-0331-742611
Fax: 39-0331-466781

Italy - Padova
Tel: 39-049-7625286

Netherlands - Drunen
Tel: 31-416-690399
Fax: 31-416-690340

Norway - Trondheim
Tel: 47-7289-7561

Poland - Warsaw
Tel: 48-22-3325737

Romania - Bucharest
Tel: 40-21-407-87-50

Spain - Madrid
Tel: 34-91-708-08-90
Fax: 34-91-708-08-91

Sweden - Gothenberg
Tel: 46-31-704-60-40

Sweden - Stockholm
Tel: 46-8-5090-4654

UK - Wokingham
Tel: 44-118-921-5800
Fax: 44-118-921-5820

Mouser Electronics

Authorized Distributor

Click to View Pricing, Inventory, Delivery & Lifecycle Information:

Microchip:

[24CW160-I/SN](#) [24CW160-I/ST](#) [24CW160T-I/OT](#) [24CW160T-I/SN](#) [24CW160T-I/ST](#) [24CW320-I/SN](#) [24CW640-I/CS0668](#) [24CW640T-I/CS1668](#) [24CW640T-I/OT](#) [24CW640T-I/SN](#) [24CW640T-I/ST](#) [24CW320-I/ST](#) [24CW320T-I/OT](#) [24CW320T-I/SN](#) [24CW320T-I/ST](#) [24CW640-I/SN](#) [24CW640-I/ST](#) [24CW160T-I/MU](#) [24CW320T-I/MU](#) [24CW640T-I/MU](#) [24CW160T-I/MUY](#) [24CW640T-I/MUY](#) [24CW320T-I/MUY](#) [24CW1280-I/SN](#) [24CW1280-I/ST](#)

Компания «Океан Электроники» предлагает заключение долгосрочных отношений при поставках импортных электронных компонентов на взаимовыгодных условиях!

Наши преимущества:

- Поставка оригинальных импортных электронных компонентов напрямую с производств Америки, Европы и Азии, а так же с крупнейших складов мира;
- Широкая линейка поставок активных и пассивных импортных электронных компонентов (более 30 млн. наименований);
- Поставка сложных, дефицитных, либо снятых с производства позиций;
- Оперативные сроки поставки под заказ (от 5 рабочих дней);
- Экспресс доставка в любую точку России;
- Помощь Конструкторского Отдела и консультации квалифицированных инженеров;
- Техническая поддержка проекта, помощь в подборе аналогов, поставка прототипов;
- Поставка электронных компонентов под контролем ВП;
- Система менеджмента качества сертифицирована по Международному стандарту ISO 9001;
- При необходимости вся продукция военного и аэрокосмического назначения проходит испытания и сертификацию в лаборатории (по согласованию с заказчиком);
- Поставка специализированных компонентов военного и аэрокосмического уровня качества (Xilinx, Altera, Analog Devices, Intersil, Interpoint, Microsemi, Actel, Aeroflex, Peregrine, VPT, Syfer, Eurofarad, Texas Instruments, MS Kennedy, Miteq, Cobham, E2V, MA-COM, Hittite, Mini-Circuits, General Dynamics и др.);

Компания «Океан Электроники» является официальным дистрибьютором и эксклюзивным представителем в России одного из крупнейших производителей разъемов военного и аэрокосмического назначения «JONHON», а так же официальным дистрибьютором и эксклюзивным представителем в России производителя высокотехнологичных и надежных решений для передачи СВЧ сигналов «FORSTAR».



JONHON

«JONHON» (основан в 1970 г.)

Разъемы специального, военного и аэрокосмического назначения:

(Применяются в военной, авиационной, аэрокосмической, морской, железнодорожной, горно- и нефтедобывающей отраслях промышленности)

«FORSTAR» (основан в 1998 г.)

ВЧ соединители, коаксиальные кабели, кабельные сборки и микроволновые компоненты:

(Применяются в телекоммуникациях гражданского и специального назначения, в средствах связи, РЛС, а так же военной, авиационной и аэрокосмической отраслях промышленности).



Телефон: 8 (812) 309-75-97 (многоканальный)

Факс: 8 (812) 320-03-32

Электронная почта: ocean@oceanchips.ru

Web: <http://oceanchips.ru/>

Адрес: 198099, г. Санкт-Петербург, ул. Калинина, д. 2, корп. 4, лит. А