

QUICK START GUIDE FOR DEMONSTRATION CIRCUIT DC631B

USB POWER SOLUTION IN QFN 5X5

LTC3455

DESCRIPTION

Demonstration circuit DC631 is a complete power solution for a USB powered device. Power is input from one of three sources, and three outputs are provided, as well as supervisory signals for a microprocessor. DC631 provides the following functions; 700mA CC/CV timer terminated charger suitable for Li-ion cells, USB power manager that insures compliance with the USB power

specification, two 1.5MHz synchronous step down converters and reset and power button status outputs for interface with a microprocessor. All this functionality consumes only 225mm² of PCB area.

Design files for this circuit board are available. Call the LTC factory.

Table 1. Performance Summary

PARAMETER	CONDITION	VALUE
Wall Adapter Input Voltage Range		4.75V-5.5V
USB Input Voltage Range		4.2V-5.5V
Battery Charger		
I _{out}	V _{in} = 5V, V _{bat} = 3.6V	700mA ±15%
Float voltage	V _{in} = 5V	4.20V±1%
Trickle Charge threshold	V _{in} = 5V (Battery voltage rising)	2.85V
Recharge threshold	V _{in} = 5V	V _{float} -150mV
USB Current		
Input Current 500mA mode	V _{in} = 5V; USB Active 500mA mode	500mA max
Input Current 100mA mode	V _{in} = 5V; USB Active 100mA mode	100mA max
Input Current suspend mode	V _{in} = 5V; USB suspend	100uA max
Buck Converters		
Switcher 1	V _{batt} 3.6V I _{out} 550mA	3.15V ±4%
Switcher 2	V _{bat} 3.6V I _{out} 400mA	1.8V ±4%
Hot Swap Output		
	V _{bat} 3.6V	100mA max

OPERATING PRINCIPLES

Demo DC631 is based on the LTC3455. This chip manages the power supplies that would be typical for a USB powered device. Power is input from either the USB cable or an adapter to an intermediate voltage bus. This intermediate voltage is then used to charge a Li-ion bat-

tery and to generate two low voltage outputs via high efficiency step down converters. The intermediate voltage bus is preferentially powered from the adapter, then USB and finally if required from the battery via an ideal diode. The battery charger is a CC/CV timer terminated

type capable of charge currents of up to 800mA and is roughly equivalent to the LTC4053. The two step down converters are high efficiency synchronous buck types similar to the LTC3405 and LTC3406. The outputs of the buck converters are set at 1.8V and 3.15V, other settings are possible by altering the feedback resistor ratios. The chip is normally ON if either USB or adapter is present. If the battery is the only source of power then the chip must be turned on by pressing the ON button, the chip can be turned off by depressing the OFF button. The off button will only function when in battery power mode. In addition to these basic functions the LTC3455 pro-

vides for some of the housekeeping functions typically associated with a small battery powered device. The LTC3455 provides a reset signal for 200msec after power up. The LTC3455 has a pin specifically designed to interface to a power ON/OFF button and reports this button status on the PBStat pin to allow the host micro-processor to shut down. Additionally there is an uncommitted op-amp that can be used as it is on the demo board as a low battery detector. Another possible use for the uncommitted op amp would be as a LDO controller to generate an additional output or to augment the peak current capability of one of the existing outputs.

QUICK START PROCEDURE

Demonstration circuit DC631 is easy to set up to evaluate the performance of the LTC3455. Refer to Figure 1 for proper measurement equipment setup and follow the procedure below:

1. Connect input power supply, meters and output load as shown in figure 1.

USB Charging

2. Place the USB Suspend Jumper in the USB Active Position. Place the USB current jumper in the 500mA position. Set the battery simulator voltage to zero, slowly raise the USB input voltage. When the supply voltage exceeds 4.1V the charger should activate and the charge LED will illuminate. The battery will be in trickle charge mode. Slowly increase the battery voltage. At about 2.85V the battery charge current will increase to 450mA. Note that the input current from the USB does not exceed the USB spec of 500mA.
3. Now increase the loads on the outputs. Note that as the output load is increased the charging current is decreased and the USB current remains within the 500mA limit.
4. Place the USB current jumper in the 100mA position and note that USB input current falls to maintain compliance with the USB input current spec. Also note that as the external load is increased the battery will start to discharge to power the Vmax intermediate voltage bus, illustrating the ideal diode function of the LTC3455

5. Place the USB Suspend jumper in the Suspend position and note that the USB current falls to under 100uA to comply with the suspend mode current.

Adapter Charging

6. Ramp up the wall adapter voltage. When the wall adapter exceeds 4.7 volts the LTC3455 will cease drawing current from the USB and switch over to the wall adapter.
7. Note that the charge current to the battery has increased to 700mA.
8. Increase the battery voltage to 4.2V and note that the charge current falls to 0 this illustrates the constant voltage portion of the charging characteristic.

Battery powered Operation

9. Set Both USB input voltage and the adapter input voltage to zero. The battery will now support the operation of the demo board.
10. In battery mode operation the OFF pushbutton is now active. Push the OFF button and note battery current draw falls to a very low level, less than 10uA.
11. Now restart the converter using the ON pushbutton. Note that the Reset LED goes on for 200msec. This simulates the Reset signal that the LTC3455 provides to the processor upon initial power up.
12. In battery mode the converter can be shifted into burst mode, by use of the burst mode jumper. In

QUICK START GUIDE FOR DEMONSTRATION CIRCUIT DC631B USB POWER SOLUTION IN QFN 5X5

burst mode the light load efficiency of the buck converters is significantly higher.

14. A hot swap output intended to power SD cards is provided and is switchable by means of a jumper.

15. Pins are provided to all control functions in order to simplify wiring of the demo card into a system board.

Other

13. The 3.15V output can be switched on and off by means of a control jumper.

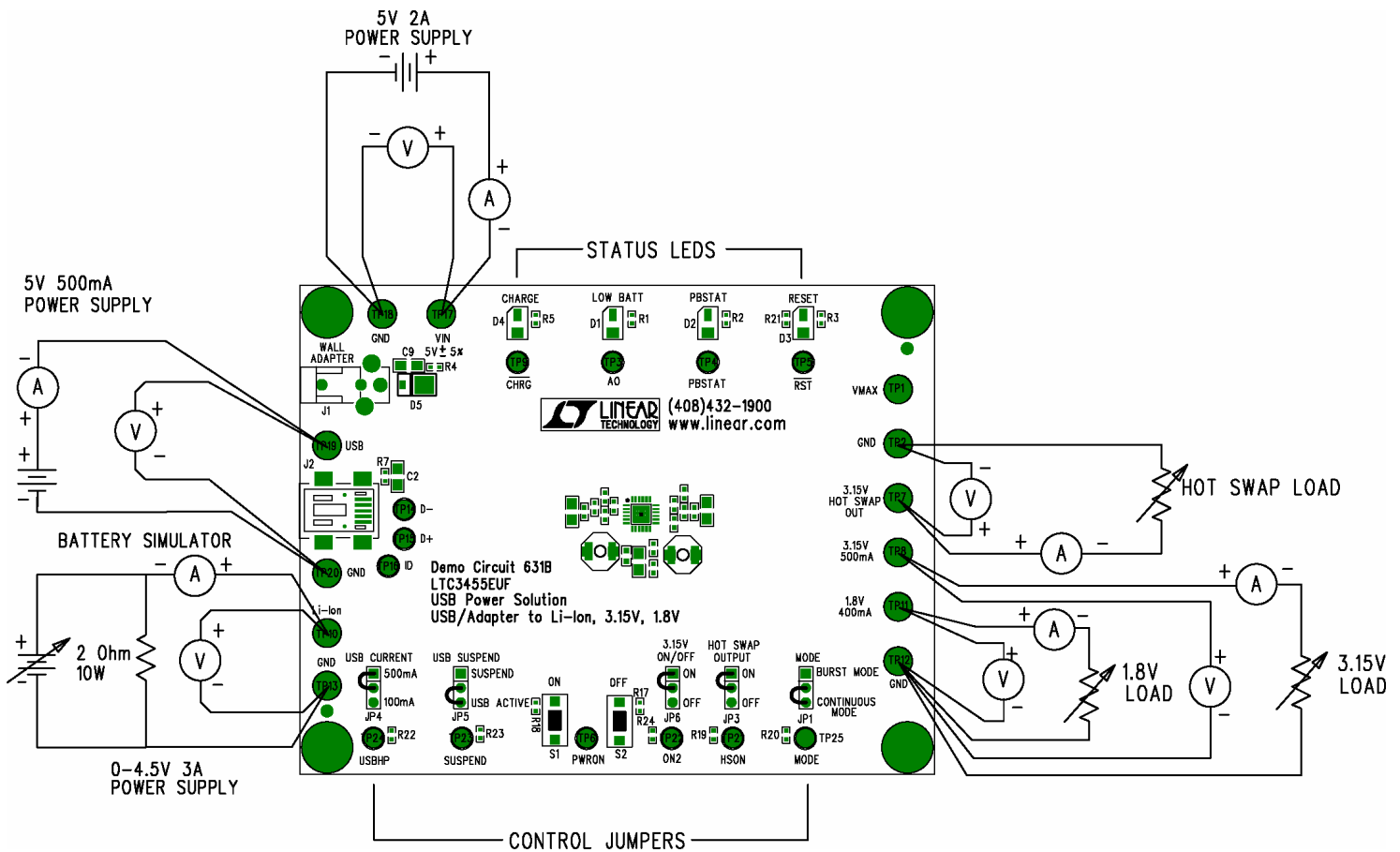
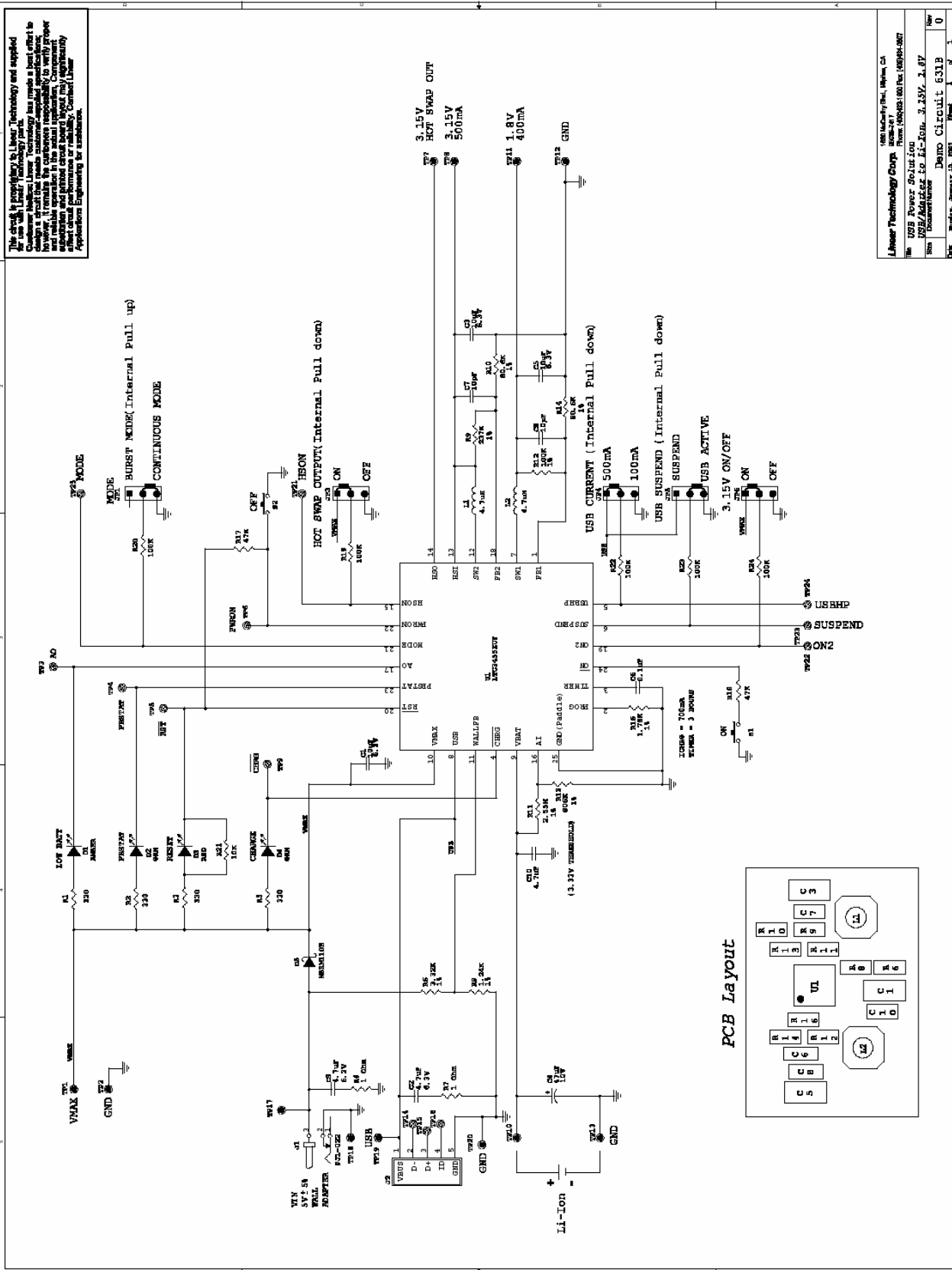

Figure 1. Proper Measurement Equipment Setup

QUICK START GUIDE FOR DEMONSTRATION CIRCUIT DC631B

USB POWER SOLUTION IN QFN 5X5



This circuit is proprietary to Linear Technology and supplied for use with Linear Technology parts. Customers using this technology may require a license from Linear Technology. Linear Technology has issued a license to verify proper use of this technology. It remains the customer's responsibility to verify proper use of this technology. Linear Technology is not responsible for any damage or loss of data or other equipment or system that may result from the use of this technology without a license from Linear Technology. Contact your Applications Engineering for assistance.

Linear Technology Corp. 1600 Technology Blvd., Wilmington, CA 94095-5081
 Phone: (925) 924-6400 Fax: (925) 924-9207
 USB Power Solution
 USB/Analog to E2-Gen-3.15V-2.8V
 Demo Circuit 631B Rev 0

Компания «Океан Электроники» предлагает заключение долгосрочных отношений при поставках импортных электронных компонентов на взаимовыгодных условиях!

Наши преимущества:

- Поставка оригинальных импортных электронных компонентов напрямую с производств Америки, Европы и Азии, а так же с крупнейших складов мира;
- Широкая линейка поставок активных и пассивных импортных электронных компонентов (более 30 млн. наименований);
- Поставка сложных, дефицитных, либо снятых с производства позиций;
- Оперативные сроки поставки под заказ (от 5 рабочих дней);
- Экспресс доставка в любую точку России;
- Помощь Конструкторского Отдела и консультации квалифицированных инженеров;
- Техническая поддержка проекта, помощь в подборе аналогов, поставка прототипов;
- Поставка электронных компонентов под контролем ВП;
- Система менеджмента качества сертифицирована по Международному стандарту ISO 9001;
- При необходимости вся продукция военного и аэрокосмического назначения проходит испытания и сертификацию в лаборатории (по согласованию с заказчиком);
- Поставка специализированных компонентов военного и аэрокосмического уровня качества (Xilinx, Altera, Analog Devices, Intersil, Interpoint, Microsemi, Actel, Aeroflex, Peregrine, VPT, Syfer, Eurofarad, Texas Instruments, MS Kennedy, Miteq, Cobham, E2V, MA-COM, Hittite, Mini-Circuits, General Dynamics и др.);

Компания «Океан Электроники» является официальным дистрибьютором и эксклюзивным представителем в России одного из крупнейших производителей разъемов военного и аэрокосмического назначения «JONHON», а так же официальным дистрибьютором и эксклюзивным представителем в России производителя высокотехнологичных и надежных решений для передачи СВЧ сигналов «FORSTAR».



JONHON

«JONHON» (основан в 1970 г.)

Разъемы специального, военного и аэрокосмического назначения:

(Применяются в военной, авиационной, аэрокосмической, морской, железнодорожной, горно- и нефтедобывающей отраслях промышленности)

«FORSTAR» (основан в 1998 г.)

ВЧ соединители, коаксиальные кабели,
кабельные сборки и микроволновые компоненты:

(Применяются в телекоммуникациях гражданского и специального назначения, в средствах связи, РЛС, а так же военной, авиационной и аэрокосмической отраслях промышленности).



Телефон: 8 (812) 309-75-97 (многоканальный)

Факс: 8 (812) 320-03-32

Электронная почта: ocean@oceanchips.ru

Web: <http://oceanchips.ru/>

Адрес: 198099, г. Санкт-Петербург, ул. Калинина, д. 2, корп. 4, лит. А