

Synchronous Buck-Boost DC/DC Converter with 2 A Switches ($V_{IN} = 2.0\text{ V to }5.5\text{ V}$, 1ch)

BD83070GWL

General Description

The BD83070GWL is a synchronous buck-boost DC/DC converter providing 3.3 V or 2.5 V output from single-cell Li-ion battery or other input between 2.0 V and 5.5 V. It has the capability to support up to 1 A output over input voltage range of 2.7 V to 5.5 V. It seamlessly changes between buck and boost operations depending on the input voltage.

It is based on pulse width modulation (PWM) and provides high efficiency for heavy load. While in PWM operation, internal FETs switch at fixed frequency 1.5 MHz typical. It automatically changes over control system to hysteresis pulse frequency modulation (PFM) to suppress switching loss and current consumption during light load. Battery drain fall down to only 2.8 μA typical at no load current. It is possible to disable auto-PFM/PWM mode by the MODE pin for suppressing output ripple and fixed frequency switching.

The device is packaged in a 1.2 mm x 1.6 mm WLCSP package.

Features

- Synchronous Buck-Boost DC/DC Converter
- Automatic PFM/PWM Transition
- Output Current: Up To 1 A ($V_{IN} > 2.7\text{ V}$, $V_{OUT} = 3.3\text{ V}$)
- Selectable Output Voltage: 2.5 V or 3.3 V
- Efficiency: Up To 95 %
- UVLO Detection: 1.61 V(Max)
- Built-in Thermal, Over Voltage, And Over Current Protection

Key Specifications

- Input Voltage Range: 2.0 V to 5.5 V
- Output Voltage: 2.5 V or 3.3 V
- Output Current: 1 A(Max)
- Switching Frequency: 1.5 MHz(Typ)
- Quiescent V_{IN} Current: 2.8 μA (Typ)
- Operating Temperature Range: -40 °C to +85 °C

Package

UCSP50L1C (12Pin) **W(Typ) x D(Typ) x H(Max)**
1.20 mm x 1.60 mm x 0.57 mm

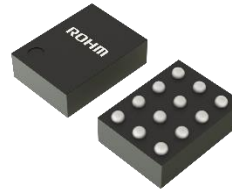

Applications

- Single Cell Li-ion or 3 Cell NiMH Battery-Powered Portable Products
- Tablet Terminal Device
- Smartphone

Typical Application Circuit

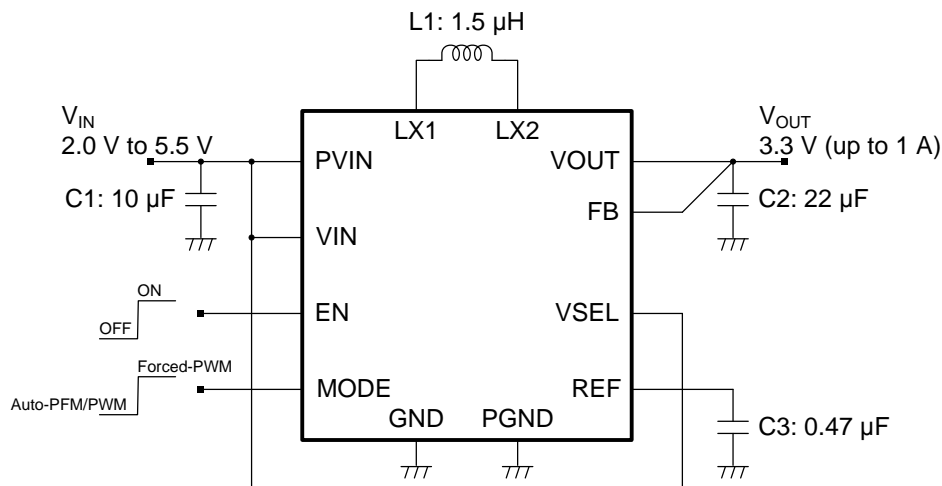

Figure 1. Typical Application Circuit

Contents

| | |
|--|----|
| General Description | 1 |
| Features..... | 1 |
| Key Specifications | 1 |
| Package..... | 1 |
| Applications | 1 |
| Typical Application Circuit | 1 |
| Contents | 2 |
| Pin Configuration | 3 |
| Pin Descriptions..... | 3 |
| Block Diagram | 4 |
| Absolute Maximum Ratings | 4 |
| Thermal Resistance..... | 5 |
| Recommended Operating Conditions..... | 5 |
| Electrical Characteristics..... | 5 |
| Detailed Descriptions..... | 7 |
| Typical Performance Curves..... | 8 |
| Application Examples | 15 |
| I/O Equivalence Circuits..... | 16 |
| Operational Notes..... | 17 |
| Ordering Information..... | 19 |
| Marking Diagram | 19 |
| Physical Dimension and Packing Information | 20 |
| Revision History..... | 21 |

Pin Configuration

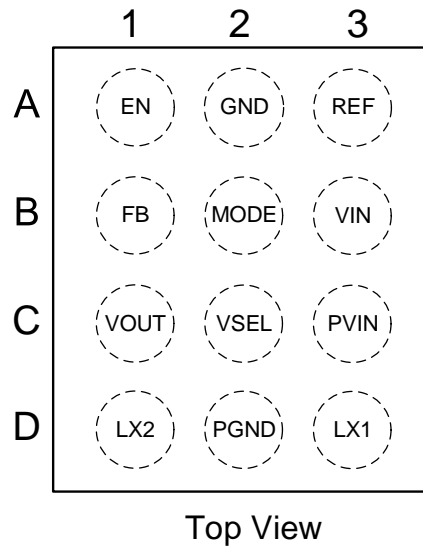

Figure 2. Pin Configuration

Pin Descriptions

| Pin No. | Pin Name | Function |
|---------|----------|--|
| A1 | EN | Enable pin of the DC/DC converter. Inputting high (≥ 1.2 V) the EN pin turns on the regulator. Inputting low (≤ 0.4 V) or open the EN pin turns off the regulator. |
| A2 | GND | Ground for sensing |
| A3 | REF | Linear regulator output for power supply of internal circuits. Connect ceramic capacitor (0.47 μ F) between this pin and the GND pin for output stability. Do not connect the other devices. |
| B1 | FB | Voltage feedback pin. Connect this pin to the VOUT pin. |
| B2 | MODE | Mode selection pin. Low (≤ 0.4 V): Auto-PFM/PWM mode. High (≥ 1.2 V): Forced-PWM mode. Do not leave this pin floating. |
| B3 | VIN | Power supply input of controller. Connect this pin to the PVIN pin. |
| C1 | VOUT | Output pin of the DC/DC converter. Connect ceramic capacitor (22 μ F recommended) between this pin and the PGND pin for output stability. |
| C2 | VSEL | Output voltage selection pin. High (V_{IN}): 3.3 V. Low (GND): 2.5 V. Connect this pin to either the VIN pin or the GND pin. |
| C3 | PVIN | Power supply input of the DC/DC converter and LX1 side gate drivers. Connect ceramic capacitor (≥ 10 μ F) between this pin and the PGND pin for power supply noise reduction. |
| D1 | LX2 | Inductor connection pin. Connect inductor (1.5 μ H) between this pin and the LX1 pin. |
| D2 | PGND | Ground of power FET, discharge, and gate drivers. |
| D3 | LX1 | Inductor connection pin. Connect inductor (1.5 μ H) between this pin and the LX2 pin. |

Block Diagram

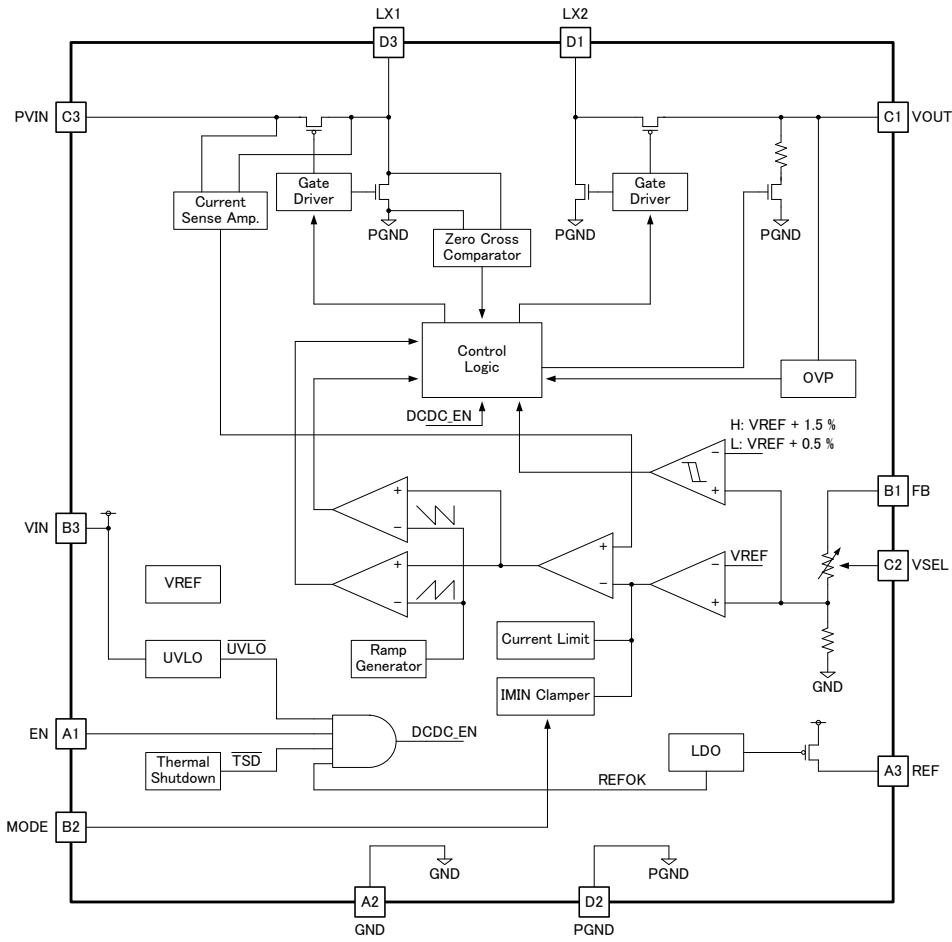

Figure 3. Block Diagram

Absolute Maximum Ratings (Ta=25 °C)

| Parameter | Symbol | Ratings | Unit |
|---|--|--------------|------|
| Voltage Range in Pins: VIN, PVIN, VOUT, FB, EN, MODE | $V_{MAXVIN}, V_{MAXPVIN}, V_{MAXVOUT},$ $V_{MAXFB}, V_{MAXEN}, V_{MAXMODE}$ | -0.3 to +6.0 | V |
| Voltage Range in Pins: LX1, LX2 <i>(Note 1)</i> | V_{MAXLX1}, V_{MAXLX2} | -1.0 to +7.0 | V |
| Voltage Range in Pin: REF | V_{MAXREF} | -0.3 to +2.1 | V |
| Voltage Range in Pin: PGND | $V_{MAXPGND}$ | -0.3 to +0.3 | V |
| Maximum Junction Temperature | Tjmax | 150 | °C |
| Storage Temperature Range | Tstg | -55 to +125 | °C |

(Note 1) Voltage transients on the LX1 or the LX2 pins beyond the DC limits specified in the absolute maximum ratings are non-disruptive to normal operation when using good layout practices as described elsewhere in the data sheet and application notes and as seen on the product demo board.

Caution 1: Operating the IC over the absolute maximum ratings may damage the IC. The damage can either be a short circuit between pins or an open circuit between pins and the internal circuitry. Therefore, it is important to consider circuit protection measures, such as adding a fuse, in case the IC is operated over the absolute maximum ratings.

Caution 2: Should by any chance the maximum junction temperature rating be exceeded the rise in temperature of the chip may result in deterioration of the properties of the chip. In case of exceeding this absolute maximum rating, design a PCB with thermal resistance taken into consideration by increasing board size and copper area so as not to exceed the maximum junction temperature rating.

Thermal Resistance (Note 2)

| Parameter | Symbol | Thermal Resistance (Typ) | | Unit |
|---------------------|---------------|----------------------------|------------------------------|------|
| | | 1s <small>(Note 3)</small> | 2s2p <small>(Note 3)</small> | |
| UCSP50L1C | | | | |
| Junction to Ambient | θ_{JA} | - | 186.6 | °C/W |

(Note 2) Based on JESD51-2A(Still-Air).(Note 3) Using a PCB board based on JESD51-9.

| Layer Number of Measurement Board | Material | Board Size |
|-----------------------------------|----------|------------------------------|
| Single | FR-4 | 114.5 mm x 101.5 mm x 1.6 mm |

| Top | |
|-----------------------|------------|
| Copper Pattern | Thickness |
| Footprints and Traces | 70 μ m |

| Layer Number of Measurement Board | Material | Board Size |
|-----------------------------------|----------|------------------------------|
| 4 Layers | FR-4 | 114.5 mm x 101.5 mm x 1.6 mm |

| Top | | 2 Internal Layers | | Bottom | |
|-----------------------|------------|-------------------|------------|-------------------|------------|
| Copper Pattern | Thickness | Copper Pattern | Thickness | Copper Pattern | Thickness |
| Footprints and Traces | 70 μ m | 99.5 mm x 99.5 mm | 35 μ m | 99.5 mm x 99.5 mm | 70 μ m |

Recommended Operating Conditions

| Parameter | Symbol | Min | Typ | Max | Unit |
|--|-----------|------|------|------|---------|
| Power Supply Voltage | V_{IN} | 2.0 | 3.6 | 5.5 | V |
| Operating Temperature | T_{opr} | -40 | +25 | +85 | °C |
| REF Connection Capacitor <small>(Note 1)</small> | C_{REF} | 0.22 | 0.47 | 1.00 | μ F |

(Note 1) The minimum value capacitance must be met this specification over full operating condition. Ceramic capacitors are recommended for input/output capacitors.Electrical Characteristics (Unless otherwise specified $V_{IN}=P_{VIN}=E_N=V_{SEL}=3.6$ V, $C_{REF}=0.47$ μ F, $T_a=25$ °C)

| Parameter | Symbol | Limit | | | Unit | Conditions |
|---------------------------------|------------|-------|-------|-------|------------|--|
| | | Min | Typ | Max | | |
| DC/DC Converter | | | | | | |
| Switching Frequency during PWM | f_{SW} | 1.35 | 1.50 | 1.65 | MHz | MODE= V_{IN} |
| Maximum Duty | D_{MAX} | 80 | 87 | 95 | % | MODE= V_{IN} |
| LX1 High Side FET ON Resistance | R_{ON1H} | - | 50 | - | m Ω | |
| LX1 Low Side FET ON Resistance | R_{ON1L} | - | 60 | - | m Ω | |
| LX2 High Side FET ON Resistance | R_{ON2H} | - | 55 | - | m Ω | $V_{OUT}=3.3$ V |
| LX2 Low Side FET ON Resistance | R_{ON2L} | - | 65 | - | m Ω | $V_{OUT}=3.3$ V |
| Over Current Protection | I_{OCP} | 2.0 | - | - | A | $P_{VIN}=3.6$ V |
| Output Voltage 1 | V_{OUT1} | 3.267 | 3.300 | 3.333 | V | MODE= V_{IN} , $V_{SEL}=V_{IN}$, No Load |
| Output Voltage 2 | V_{OUT2} | 2.468 | 2.500 | 2.532 | V | MODE= V_{IN} , $V_{SEL}=0$ V, No Load |
| Load Regulation | V_{LR} | - | 0.5 | - | mV | MODE= V_{IN} , $V_{SEL}=V_{IN}$ $I_{OUT}=0$ mA to 1000 mA |

Electrical Characteristics - continued (Unless otherwise specified VIN=PVIN=EN=VSEL=3.6 V, C_{REF}=0.47 μF, Ta=25 °C)

| Parameter | Symbol | Limit | | | Unit | Conditions | |
|------------------------------------|---------|----------------------|----------------------|-------|----------------------|------------|--|
| | | Min | Typ | Max | | | |
| DC/DC Converter - continued | | | | | | | |
| Over Voltage Threshold | Detect | V _{OVPEDET} | 5.3 | 5.5 | 5.7 | V | V _{OUT} voltage increasing |
| | Release | V _{OVPRST} | 5.2 | 5.4 | 5.6 | V | V _{OUT} voltage decreasing |
| Startup Delay Time | | t _{ST} | - | 4.9 | - | ms | From EN=High to V _{OUT} =100 mV |
| Startup Slew Rate | | SR _{ST} | 2.5 | 5.0 | 10.0 | mV/μs | |
| Discharge Resistance | | R _{DG} | 40 | 85 | 200 | Ω | EN=0 V |
| Short Circuit Threshold | Detect | V _{SCPDET} | 1.3 | 1.4 | 1.5 | V | FB voltage decreasing |
| | Release | V _{SCRST} | 1.51 | 1.61 | 1.71 | V | FB voltage increasing |
| Main Controller | | | | | | | |
| Under Voltage Lockout Threshold | Up | V _{UVLOUP} | - | 1.740 | 1.990 | V | V _{IN} voltage increasing |
| | Down | V _{UVLODN} | 1.51 | 1.56 | 1.61 | V | V _{IN} voltage decreasing |
| EN Pin Control Voltage | ON | V _{ENH} | 1.2 | - | 5.5 | V | |
| | OFF | V _{ENL} | -0.3 | - | +0.4 | V | |
| EN Pin Input Current | | I _{EN} | - | 200 | 500 | nA | |
| MODE Pin Control Voltage | High | V _{MODEH} | 1.2 | - | 5.5 | V | |
| | Low | V _{MODEL} | -0.3 | - | +0.4 | V | |
| VSEL Pin Control Voltage | High | V _{VSELH} | V _{IN} -0.3 | - | V _{IN} +0.3 | V | |
| | Low | V _{VSELL} | -0.3 | - | +0.3 | V | |
| REF Output Voltage | | V _{REF} | 1.45 | 1.50 | 1.55 | V | I _{REF} =-100 μA |
| Whole Device | | | | | | | |
| Quiescent VIN Current | | I _{VIN} | - | 2.8 | 5.6 | μA | MODE=0 V, FB=3.5 V |
| Quiescent FB Current | | I _{FB} | - | 0.2 | 0.4 | μA | MODE=0 V, FB=3.5 V |
| Shutdown VIN Current | | I _{SHD} | - | 0.1 | 1.0 | μA | EN=0 V |

Detailed Descriptions

1. Startup and Shutdown Control

When the EN pin goes from low (input under 0.4 V or open) to high (input over 1.2 V), the BD83070GWL turns on internal LDO, REF, and the DC/DC converter. There is typically 4.9 ms delay from the EN high edge to startup of DC/DC converter (t_{ST}). It has a soft-start structure and ramps up the output voltage in 5 mV/ μ s typically (SR_{ST}). On the other hand, when the EN pin goes from high to low, it disables the internal LDO and DC/DC immediately. While in shutdown, it turns discharge switch on to pull V_{OUT} to ground through 85 Ω typically. If the EN pin goes again from low to high during discharge sequence, the output voltage is ramped up from remaining voltage to target voltage in 5 mV/ μ s(Typ).

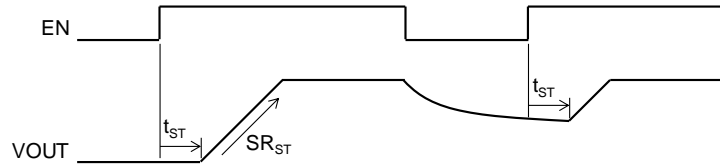

Figure 4. Startup Sequence

2. MODE Pin

In the case of the MODE pin is pulled high (over 1.2 V), the BD83070GWL operates in forced PWM mode and uses fixed frequency 1.5 MHz regardless its loads. If the MODE pin is pulled low (under 0.4 V), it operates in automatic PFM-PWM mode and automatically changes over from PWM to hysteresis PFM operation depending on its loads. Do not leave this pin floating because it is neither pulled down nor up, internally.

3. Output Voltage Setting

The BD83070GWL has internal feedback resistors. It is possible to select target output voltage from either 2.5 V or 3.3 V by the VSEL pin. If the VSEL pin is connected to ground, the nominal output voltage is 2.5 V. On the other hand when the VSEL is connected to V_{IN} , the nominal output voltage is 3.3 V. It is not recommended to change while in EN is logic high.

4. Maximum Load Current

The maximum load current varies depending on PVIN voltage and output voltage setting. When using the recommended application, the maximum load current becomes as follows.

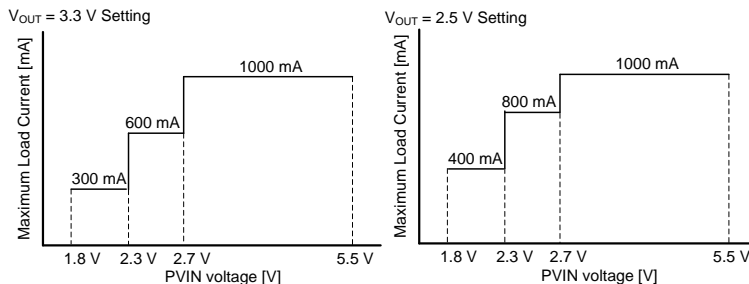

Figure 5. Maximum Load Current

5. Current Limit Protection

The BD83070GWL has a current limit protection circuit to prevent excessive electric stress on itself and external inductor at overload condition.

6. Short Circuit Protection

If FB voltage drops less than 1.4 V(Typ), the current limit value is reduced to about half of the normal that. The current limit value returns to the normal that when the FB voltage exceeds 1.61 V(Typ).

7. Over Voltage Protection

The BD83070GWL has an over voltage comparator. When the FB pin becomes open, the output voltage rises beyond target voltage. If the VOUT pin reaches 5.5 V(Typ), it stops switching to prevent over voltage stress on its power FETs. If the VOUT pin voltage falls lower than 5.4 V(Typ), it restarts switching.

8. Under Voltage Lockout (UVLO)

The BD83070GWL has a UVLO comparator to turn the device off and prevent malfunction when the input voltage is too low. As same as UVLO, it has a REFOK comparator to monitor REF voltage, internal LDO output, and turns the device off when the REF voltage is too low.

9. Thermal Shutdown

The BD83070GWL has a Thermal Shutdown Circuit (TSD Circuit). When the temperature of its chip is higher than 175 °C typical, the TSD circuit turns off the DC/DC converter. There is the hysteresis width of 20 °C between the detection point and release point to prevent malfunctions from temperature fluctuations. Because TSD Circuit is only designed for protecting the device from thermal over load, it is not recommended to design the application as TSD working in normal condition.

Typical Performance Curves

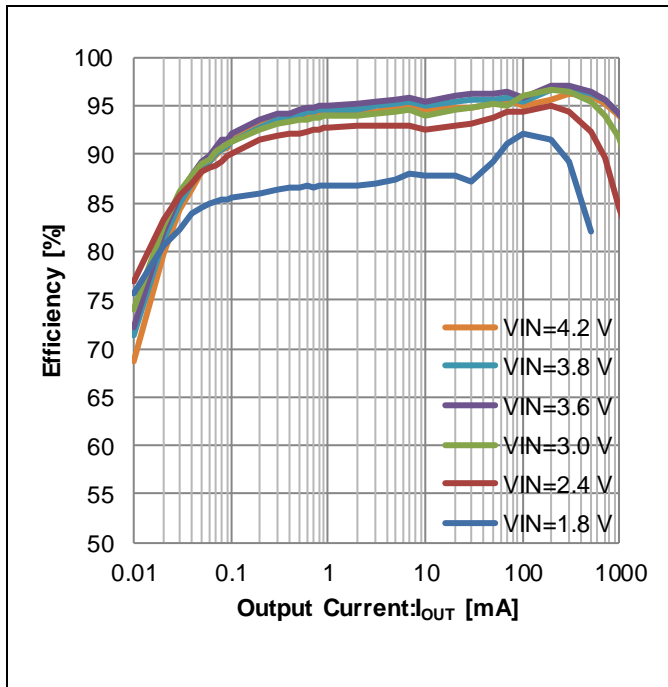

Figure 6. Efficiency vs Output Current (VSEL=High, MODE=Low: Auto-PFM/PWM)

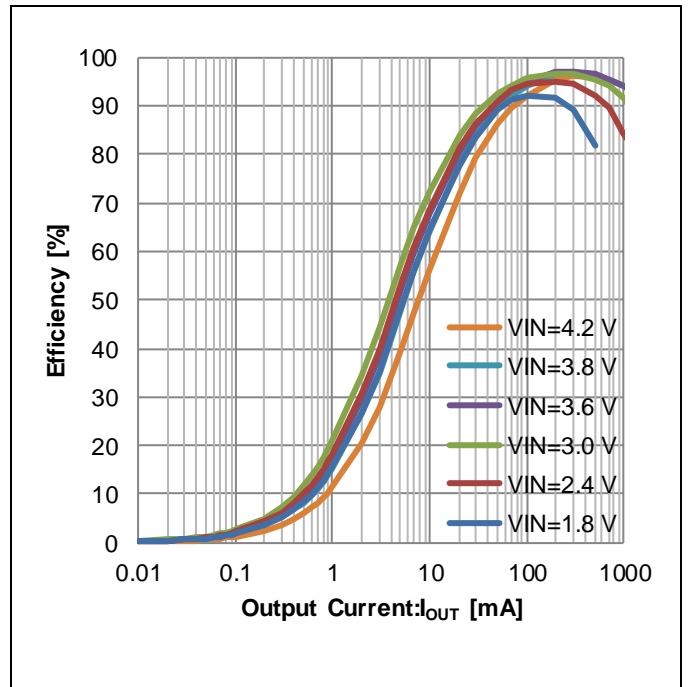

Figure 7. Efficiency vs Output Current (VSEL=High, MODE=High: Forced-PWM)

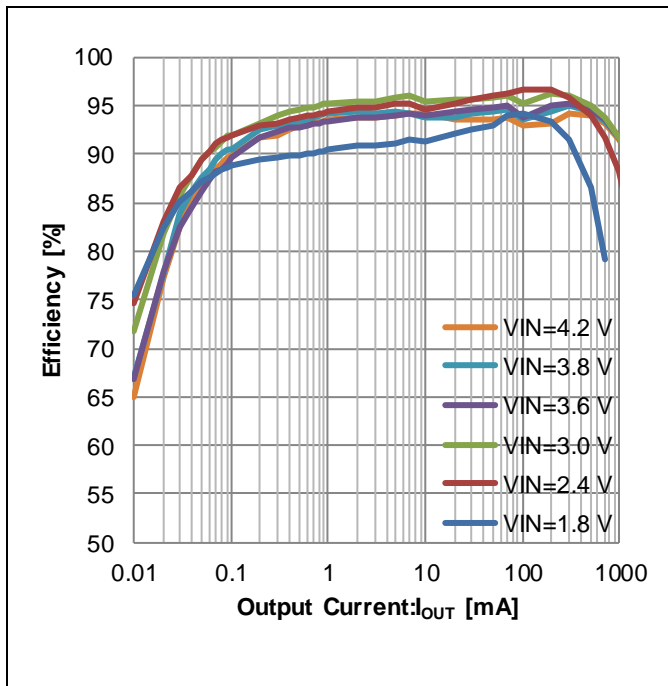

Figure 8. Efficiency vs Output Current (VSEL=Low, MODE=Low: Auto-PFM/PWM)

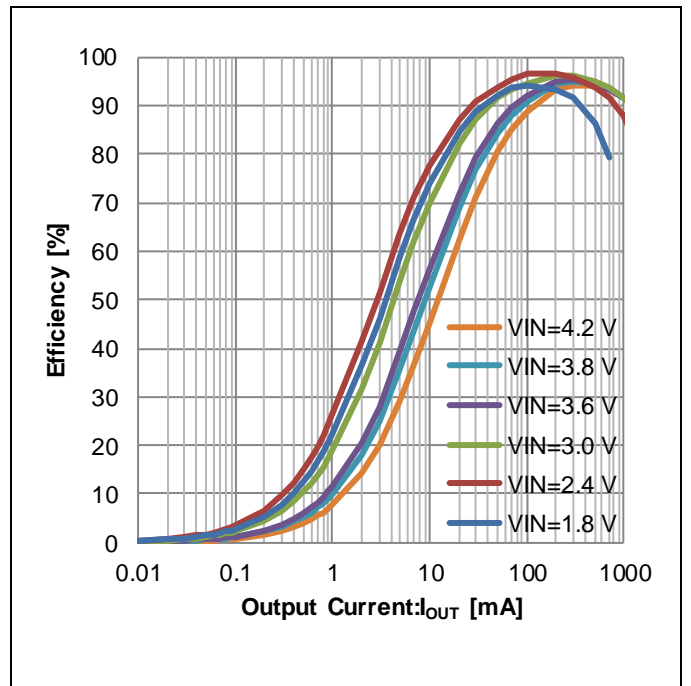

Figure 9. Efficiency vs Output Current (VSEL=Low, MODE=High: Forced-PWM)

Typical Performance Curves - continued

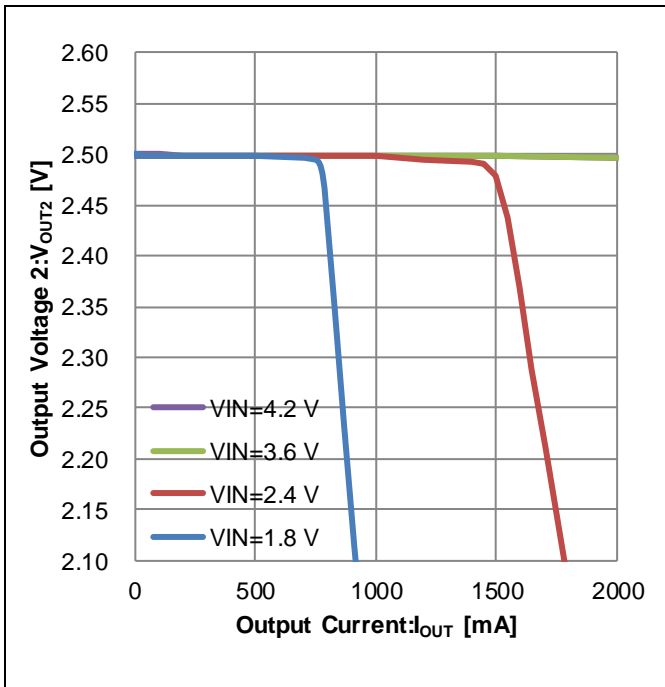

Figure 10. Output Voltage 2 vs Output Current (“Load Regulation”, VSEL=Low, MODE=High: Forced-PWM)

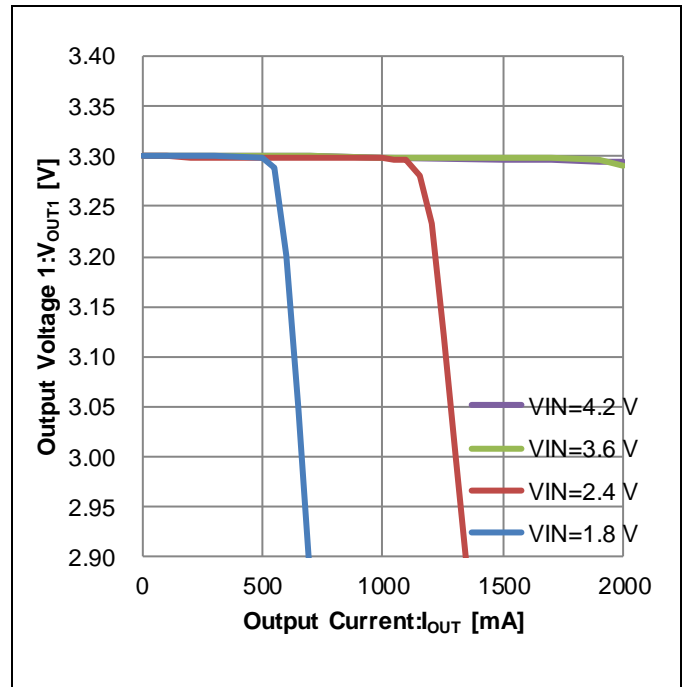

Figure 11. Output Voltage 1 vs Output Current (“Load Regulation”, VSEL=High, MODE=High: Forced-PWM)

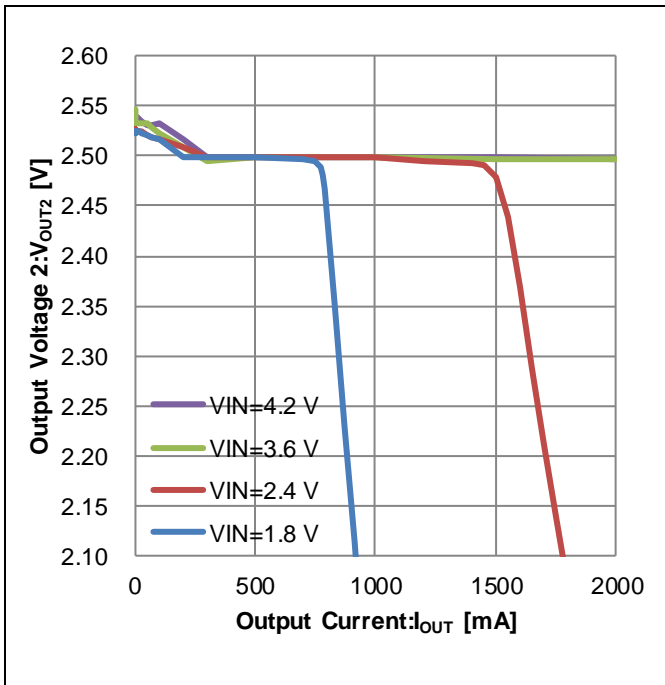

Figure 12. Output Voltage 2 vs Output Current (“Load Regulation”, VSEL=Low, MODE=Low: Auto-PFM/PWM)

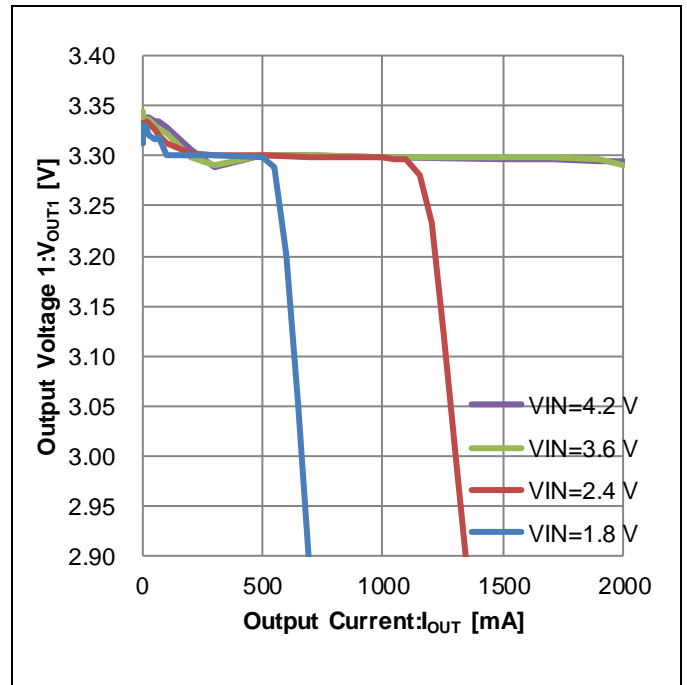

Figure 13. Output Voltage 1 vs Output Current (“Load Regulation”, VSEL=High, MODE=Low: Auto-PFM/PWM)

Typical Performance Curves - continued

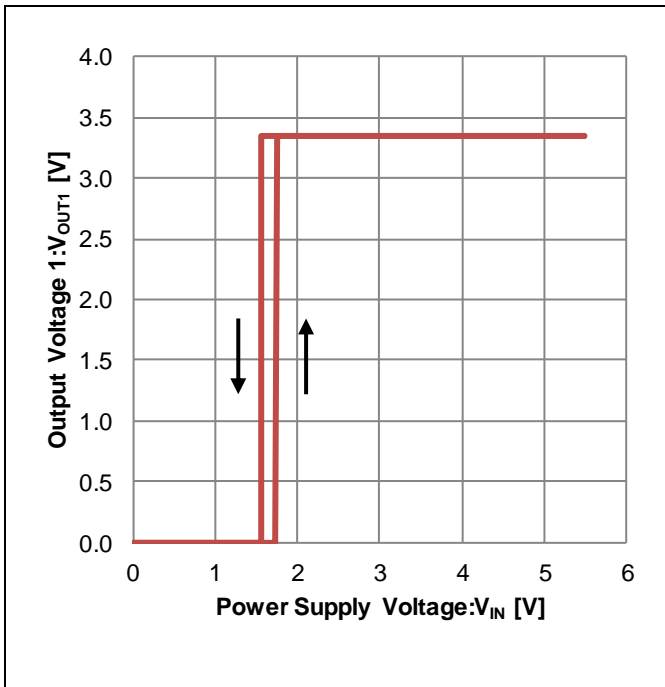

Figure 14. Output Voltage 1 vs Power Supply Voltage ("Line Regulation", EN=VSEL=High, MODE=Low: Auto-PFM/PWM, 3.3 kΩ resistive load)

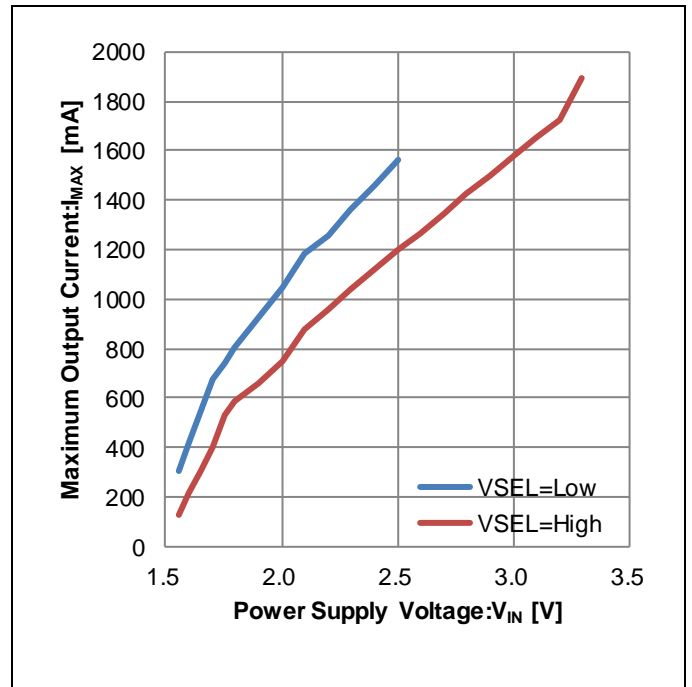

Figure 15. Maximum Output Current vs Power Supply Voltage

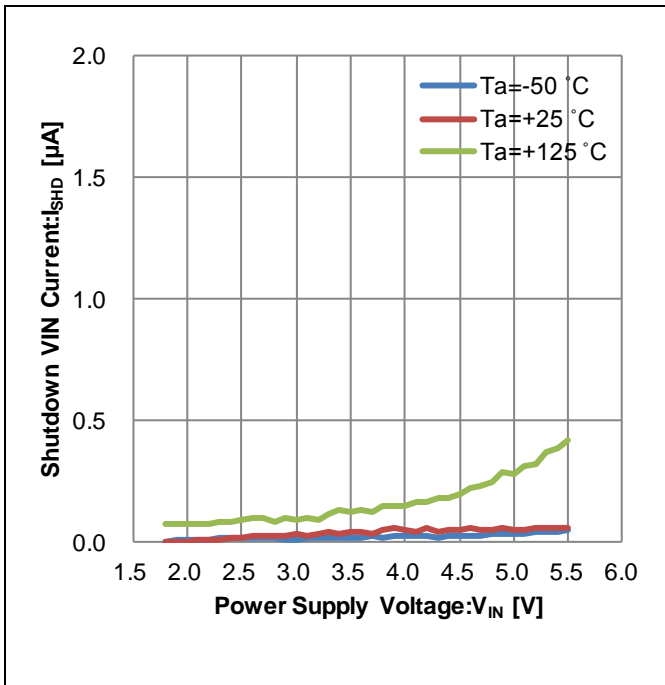

Figure 16. Shutdown VIN Current vs Power Supply Voltage (EN=MODE=Low, No load)

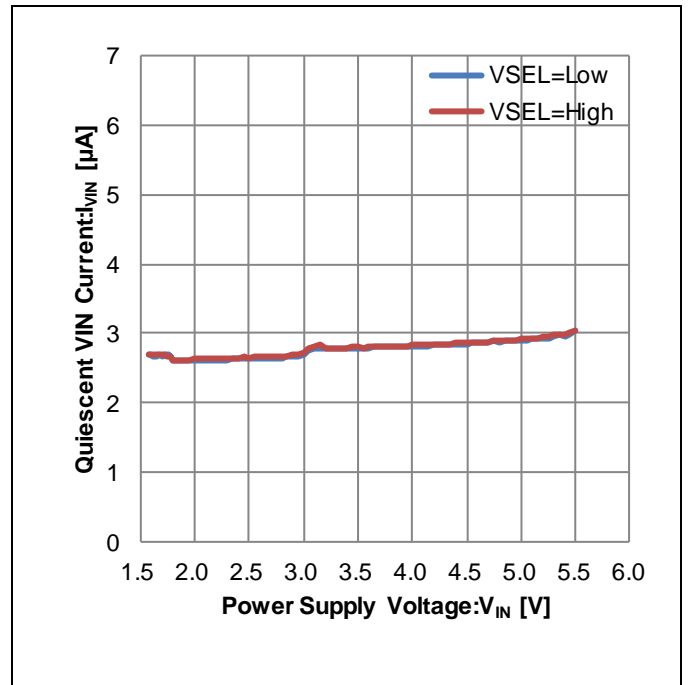

Figure 17. Quiescent VIN Current vs Power Supply Voltage (MODE=Low: Auto-PFM/PWM, FB=3.5 V, No load)

Typical Performance Curves - continued

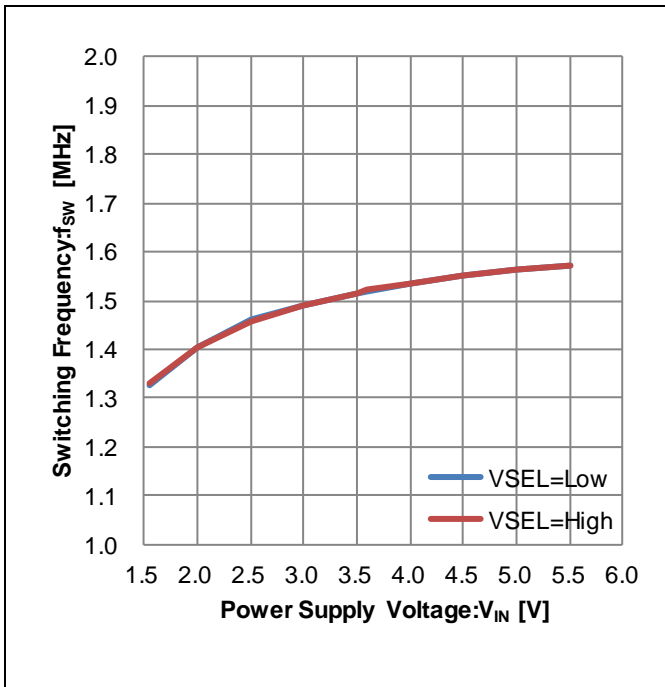

Figure 18. Switching Frequency vs Power Supply Voltage (MODE=High: Forced-PWM, No load)

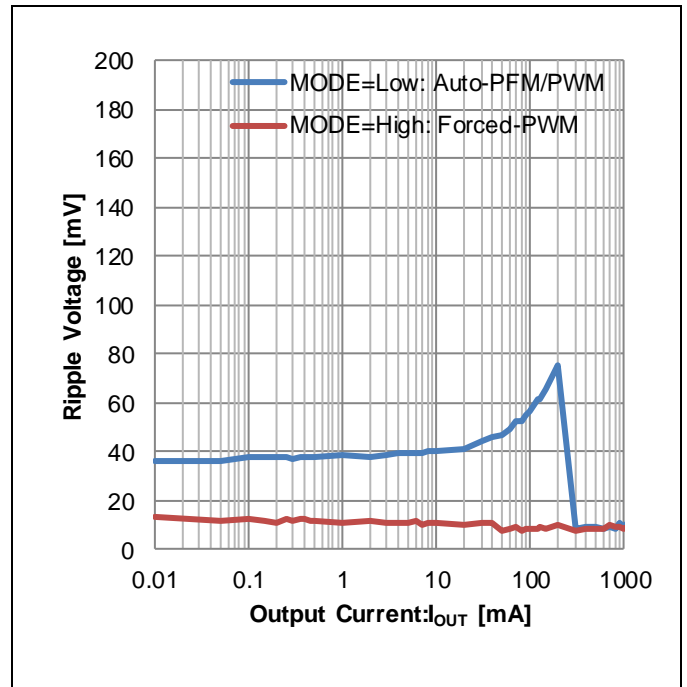

Figure 19. Ripple Voltage vs Output Current (VIN=3.6 V, VSEL=High)

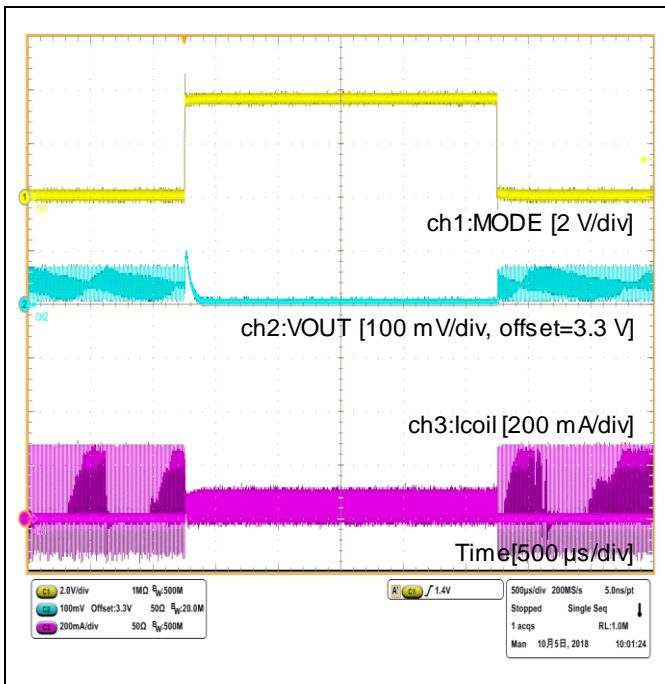

Figure 20. Transient Response ("Mode Change", VIN=3.6 V, VSEL=High, MODE=Low->High, Output current 50 mA)

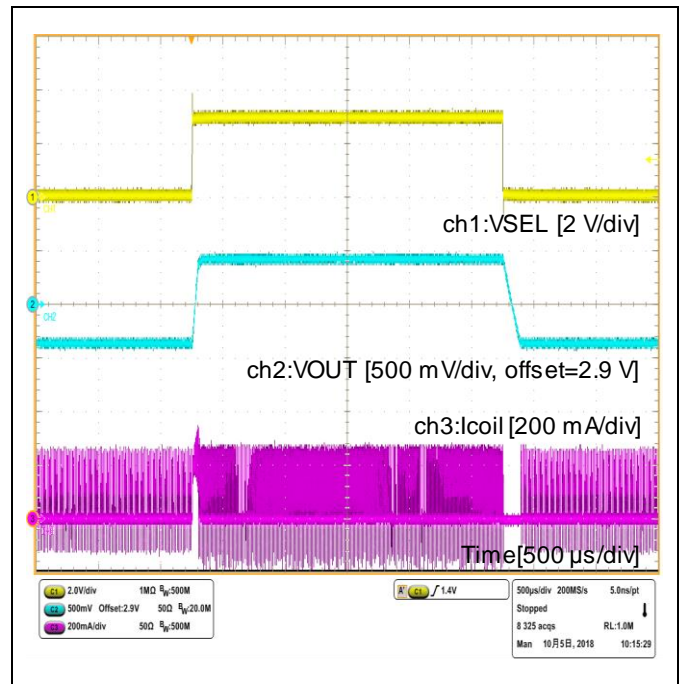

Figure 21. Transient Response ("Output Voltage Change", VIN=2.9 V, VSEL=Low->High, MODE=Low: Auto-PFM/PWM, Output current 50 mA)

Typical Performance Curves - continued

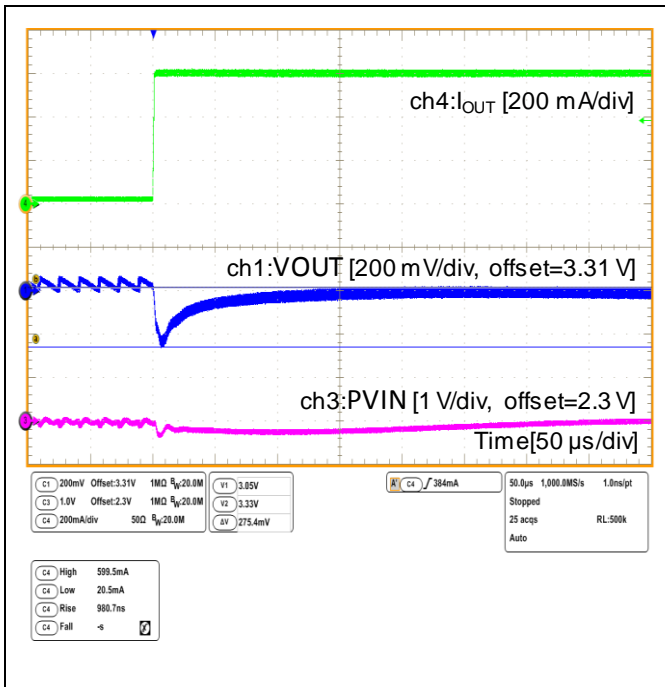

Figure 22. Transient Response (VIN=2.3 V, VSEL=High, MODE=Low: Auto-PFM/PWM, Output current 20 mA->600 mA)

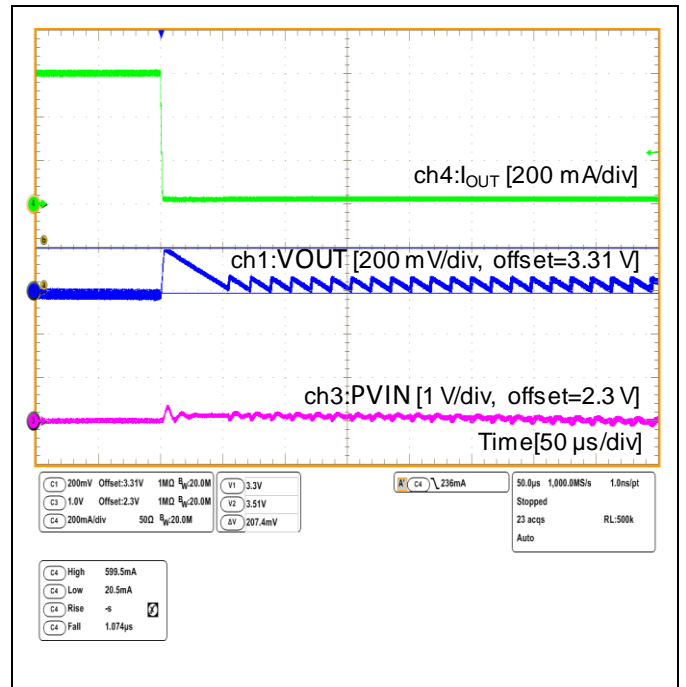

Figure 23. Transient Response (VIN=2.3 V, VSEL=High, MODE=Low: Auto-PFM/PWM, Output current 600 mA->20 mA)

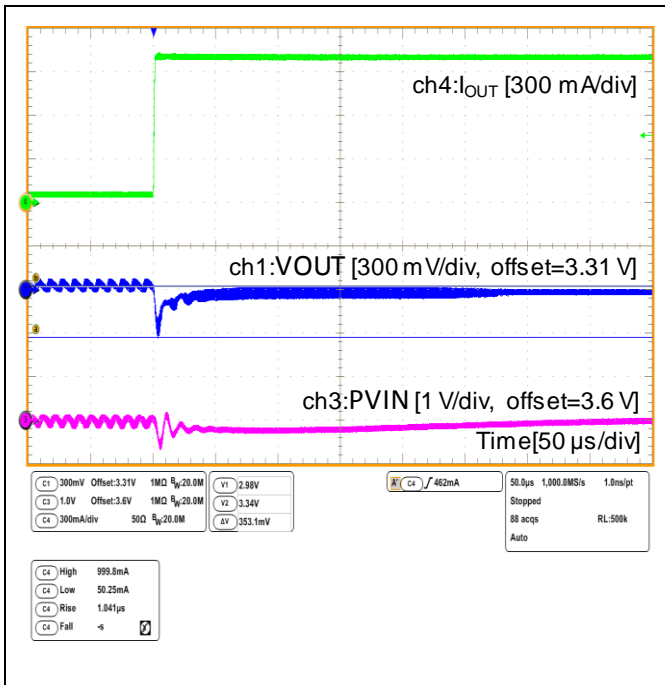

Figure 24. Transient Response (VIN=3.6 V, VSEL=High, MODE=Low: Auto-PFM/PWM, Output current 50 mA->1000 mA)

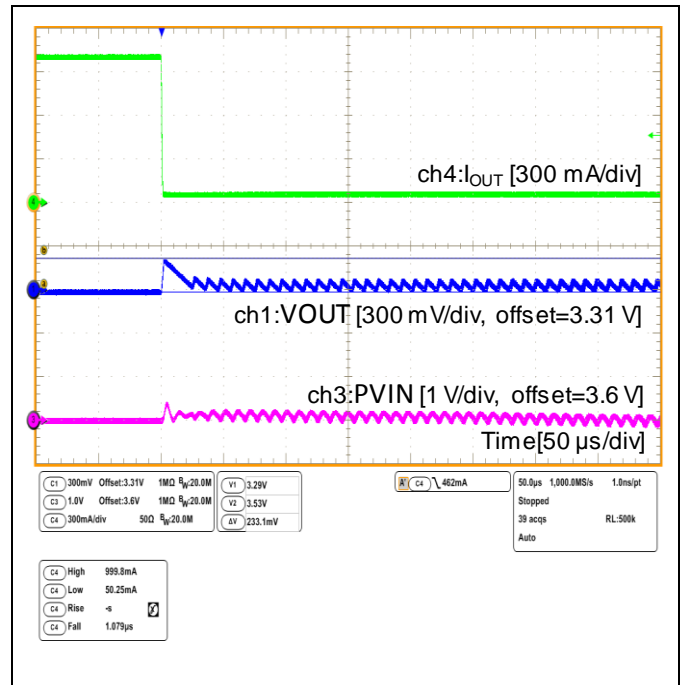

Figure 25. Transient Response (VIN=3.6 V, VSEL=High, MODE=Low: Auto-PFM/PWM, Output current 1000 mA->50 mA)

Typical Performance Curves - continued

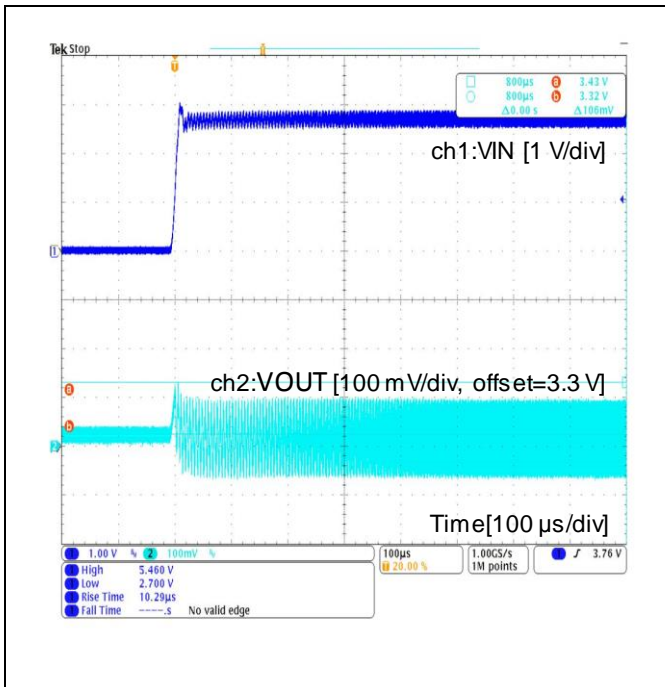

Figure 26. Transient Response
(VIN=2.7 V->5.5 V, VSEL=High, MODE=Low:
Auto-PFM/PWM, Output current 300 mA)

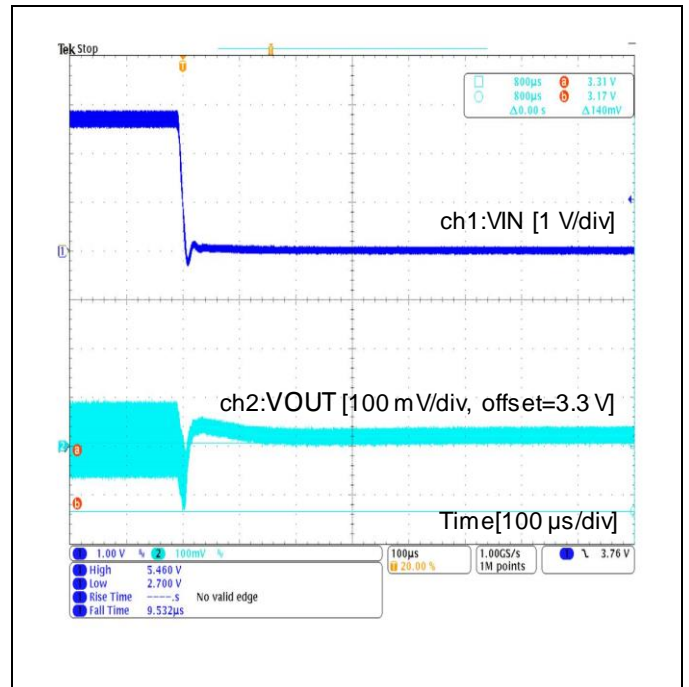

Figure 27. Transient Response
(VIN=5.5 V->2.7 V, VSEL=High, MODE=Low:
Auto-PFM/PWM, Output current 300 mA)

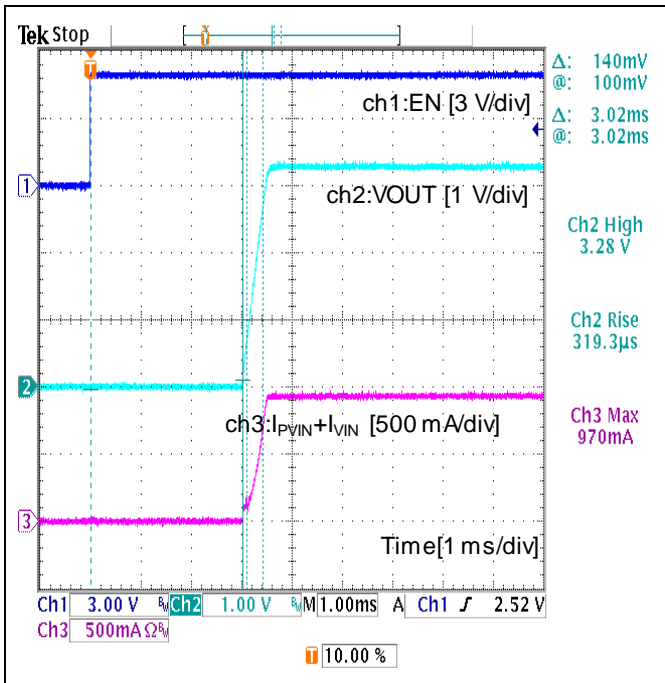

Figure 28. Startup Waveform
(VIN=2.4 V, VSEL=High, MODE=High: Forced-PWM,
5.5 Ω resistive load)

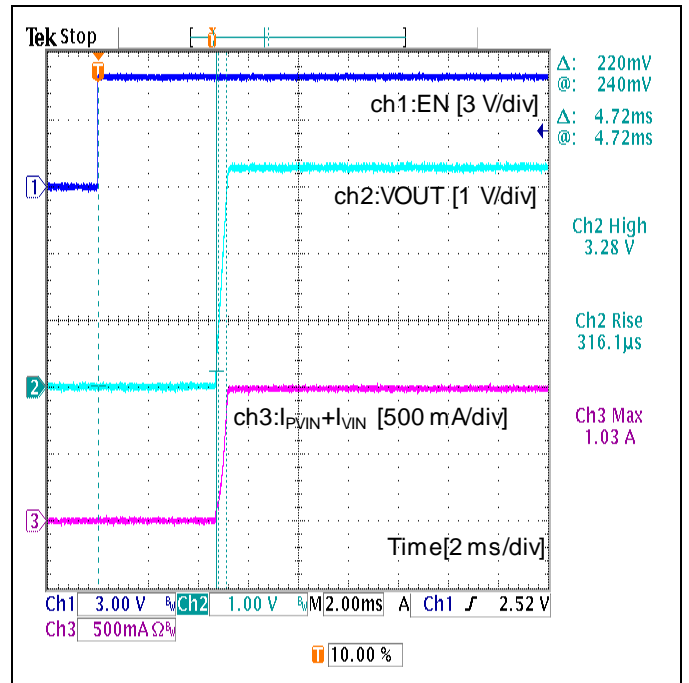

Figure 29. Startup Waveform
(VIN=3.6 V, VSEL=High, MODE=High: Forced-PWM,
3.3 Ω resistive load)

Typical Performance Curves - continued

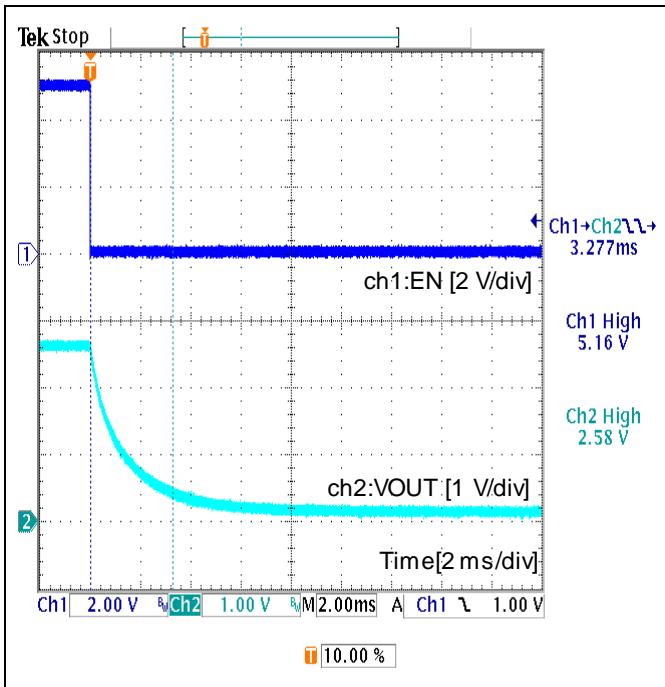

Figure 30. Shutdown Waveform
(VIN=3.6 V, VSEL=Low, MODE=Low: Auto-PFM/PWM, No load)

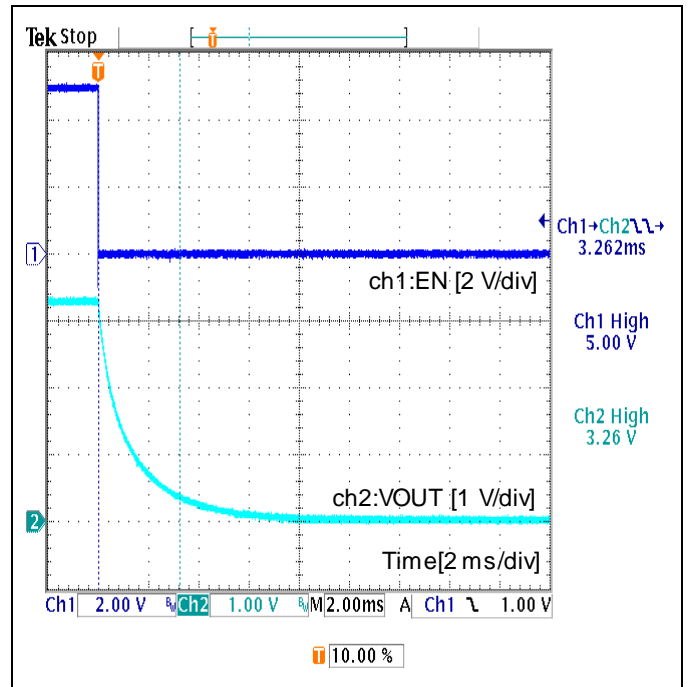

Figure 31. Shutdown Waveform
(VIN=3.6 V, VSEL=High, MODE=Low: Auto-PFM/PWM, No load)

Application Examples

VSEL = V_{IN} (V_{OUT} = 3.3 V setting)

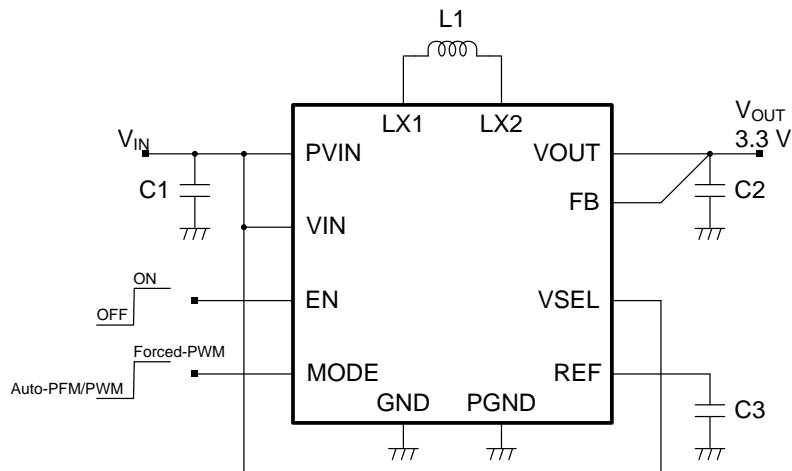

Figure 32. 3.3V Output Application Circuit

VSEL = GND (V_{OUT} = 2.5 V setting)

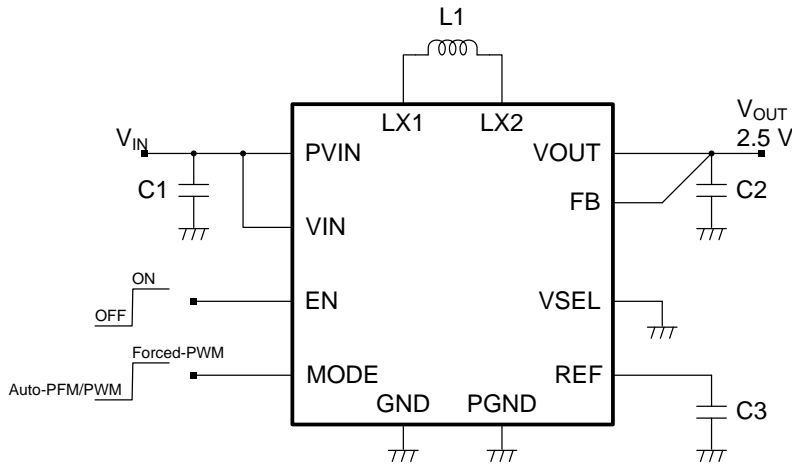

Figure 33. 2.5 V Output Application Circuit

| Parts Number | Description | Supplier |
|------------------------|---|-------------|
| L1 | 1239AS-H-1R5M (1.5 μH, 2.5 mm x 2.0 mm x 1.2 mm) | muRata |
| C1 | EMK212ABJ106KD (10 μF, 16 V, X5R, 0805) | Taiyo Yuden |
| C2 ^(Note 1) | JMK107BBJ226MA (22 μF, 6.3 V, X5R, 0603) | Taiyo Yuden |
| C3 | EMK105ABJ474KV-F (0.47 μF, 16 V, X5R, 0402) | Taiyo Yuden |

(Note 1) The effective load capacitance value considering accuracy, temperature characteristic and DC bias characteristic of output capacitors should not be less than 22 μF. The amount of output capacitance will have a significant effect on the output ripple voltage.

I/O Equivalence Circuits

| Pin Name | Equivalence circuit | Pin Name | Equivalence circuit |
|-----------|---------------------|----------|---------------------|
| EN | | VOUT | |
| REF | | PVIN | |
| FB | | LX2 | |
| MODE VSEL | | PGND | |
| VIN | | LX1 | |

Operational Notes

1. Reverse Connection of Power Supply

Connecting the power supply in reverse polarity can damage the IC. Take precautions against reverse polarity when connecting the power supply, such as mounting an external diode between the power supply and the IC's power supply pins.

2. Power Supply Lines

Design the PCB layout pattern to provide low impedance supply lines. Furthermore, connect a capacitor to ground at all power supply pins. Consider the effect of temperature and aging on the capacitance value when using electrolytic capacitors.

3. Ground Voltage

Ensure that no pins are at a voltage below that of the ground pin at any time, even during transient condition.

4. Ground Wiring Pattern

When using both small-signal and large-current ground traces, the two ground traces should be routed separately but connected to a single ground at the reference point of the application board to avoid fluctuations in the small-signal ground caused by large currents. Also ensure that the ground traces of external components do not cause variations on the ground voltage. The ground lines must be as short and thick as possible to reduce line impedance.

5. Recommended Operating Conditions

The function and operation of the IC are guaranteed within the range specified by the recommended operating conditions. The characteristic values are guaranteed only under the conditions of each item specified by the electrical characteristics.

6. Inrush Current

When power is first supplied to the IC, it is possible that the internal logic may be unstable and inrush current may flow instantaneously due to the internal powering sequence and delays, especially if the IC has more than one power supply. Therefore, give special consideration to power coupling capacitance, power wiring, width of ground wiring, and routing of connections.

7. Testing on Application Boards

When testing the IC on an application board, connecting a capacitor directly to a low-impedance output pin may subject the IC to stress. Always discharge capacitors completely after each process or step. The IC's power supply should always be turned off completely before connecting or removing it from the test setup during the inspection process. To prevent damage from static discharge, ground the IC during assembly and use similar precautions during transport and storage.

8. Inter-pin Short and Mounting Errors

Ensure that the direction and position are correct when mounting the IC on the PCB. Incorrect mounting may result in damaging the IC. Avoid nearby pins being shorted to each other especially to ground, power supply and output pin. Inter-pin shorts could be due to many reasons such as metal particles, water droplets (in very humid environment) and unintentional solder bridge deposited in between pins during assembly to name a few.

9. Unused Input Pins

Input pins of an IC are often connected to the gate of a MOS transistor. The gate has extremely high impedance and extremely low capacitance. If left unconnected, the electric field from the outside can easily charge it. The small charge acquired in this way is enough to produce a significant effect on the conduction through the transistor and cause unexpected operation of the IC. So unless otherwise specified, unused input pins should be connected to the power supply or ground line.

Operational Notes – continued

10. Regarding the Input Pin of the IC

This monolithic IC contains P+ isolation and P substrate layers between adjacent elements in order to keep them isolated. P-N junctions are formed at the intersection of the P layers with the N layers of other elements, creating a parasitic diode or transistor. For example (refer to figure below):

When $GND > Pin A$ and $GND > Pin B$, the P-N junction operates as a parasitic diode.

When $GND > Pin B$, the P-N junction operates as a parasitic transistor.

Parasitic diodes inevitably occur in the structure of the IC. The operation of parasitic diodes can result in mutual interference among circuits, operational faults, or physical damage. Therefore, conditions that cause these diodes to operate, such as applying a voltage lower than the GND voltage to an input pin (and thus to the P substrate) should be avoided.

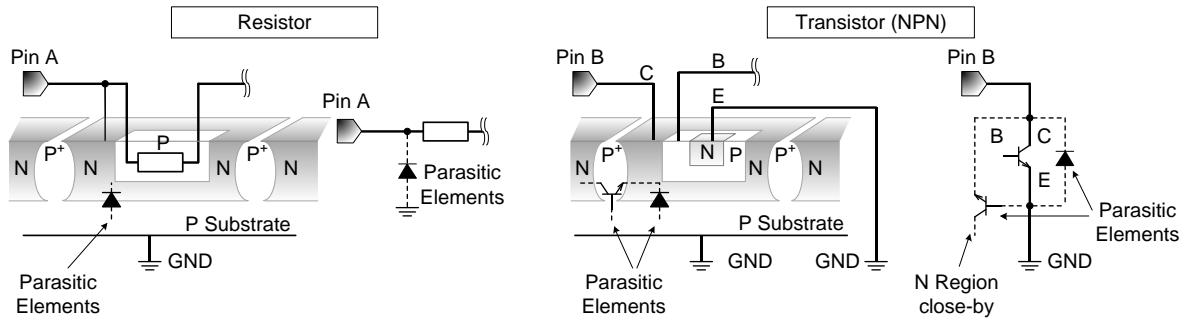

Figure 34. Example of Monolithic IC Structure

11. Ceramic Capacitor

When using a ceramic capacitor, determine a capacitance value considering the change of capacitance with temperature and the decrease in nominal capacitance due to DC bias and others.

12. Thermal Shutdown Circuit (TSD)

This IC has a built-in thermal shutdown circuit that prevents heat damage to the IC. Normal operation should always be within the IC's maximum junction temperature rating. If however the rating is exceeded for a continued period, the junction temperature (T_j) will rise which will activate the TSD circuit that will turn OFF power output pins. When the T_j falls below the TSD threshold, the circuits are automatically restored to normal operation.

Note that the TSD circuit operates in a situation that exceeds the absolute maximum ratings and therefore, under no circumstances, should the TSD circuit be used in a set design or for any purpose other than protecting the IC from heat damage.

13. Over Current Protection Circuit (OCP)

This IC incorporates an integrated overcurrent protection circuit that is activated when the load is shorted. This protection circuit is effective in preventing damage due to sudden and unexpected incidents. However, the IC should not be used in applications characterized by continuous operation or transitioning of the protection circuit.

14. Disturbance Light

In a device where a portion of silicon is exposed to light such as in a WL-CSP and chip products, IC characteristics may be affected due to photoelectric effect. For this reason, it is recommended to come up with countermeasures that will prevent the chip from being exposed to light.

Ordering Information

B D 8 3 0 7 0 G W L

E 2

Part Number

Package
GWL: UCSP50L1C

Packaging and forming specification
E2: Embossed tape and reel

Marking Diagram

TOP VIEW
UCSP50L1C (BD83070GWL)

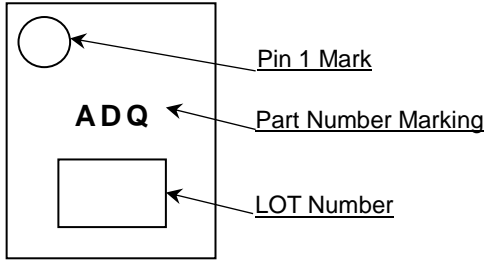

Physical Dimension and Packing Information

| | |
|--------------|-----------------------|
| Package Name | UCSP50L1C(BD83070GWL) |
|--------------|-----------------------|

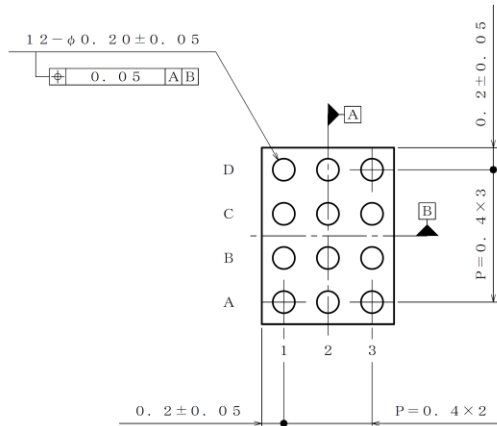
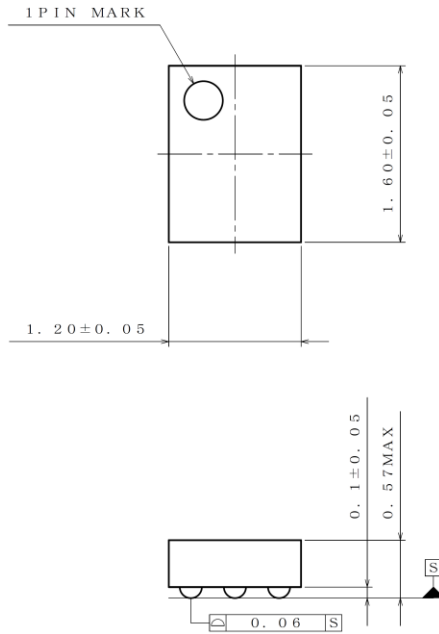

(UNIT : mm)

< Tape and Reel Information >

| | |
|-------------------|--|
| Tape | Embossed carrier tape |
| Quantity | 3,000pcs |
| Direction of feed | E2 The direction is the pin 1 of product is at the upper left when you hold reel on the left hand and you pull out the tape on the right hand |

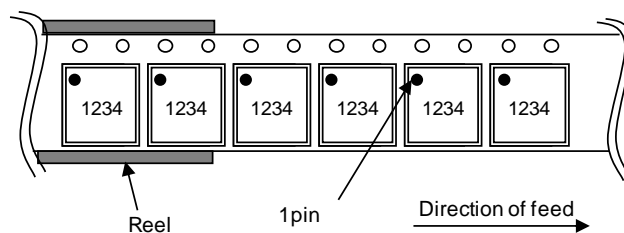

Revision History

| Date | Revision | Changes |
|-------------|----------|-------------|
| 09.Oct.2018 | 001 | New Release |

Notice

Precaution on using ROHM Products

- Our Products are designed and manufactured for application in ordinary electronic equipment (such as AV equipment, OA equipment, telecommunication equipment, home electronic appliances, amusement equipment, etc.). If you intend to use our Products in devices requiring extremely high reliability (such as medical equipment ^(Note 1), transport equipment, traffic equipment, aircraft/spacecraft, nuclear power controllers, fuel controllers, car equipment including car accessories, safety devices, etc.) and whose malfunction or failure may cause loss of human life, bodily injury or serious damage to property ("Specific Applications"), please consult with the ROHM sales representative in advance. Unless otherwise agreed in writing by ROHM in advance, ROHM shall not be in any way responsible or liable for any damages, expenses or losses incurred by you or third parties arising from the use of any ROHM's Products for Specific Applications.

(Note1) Medical Equipment Classification of the Specific Applications

| JAPAN | USA | EU | CHINA |
|-----------|-----------|------------|-----------|
| CLASS III | CLASS III | CLASS II b | CLASS III |
| CLASS IV | | CLASS III | |

- ROHM designs and manufactures its Products subject to strict quality control system. However, semiconductor products can fail or malfunction at a certain rate. Please be sure to implement, at your own responsibilities, adequate safety measures including but not limited to fail-safe design against the physical injury, damage to any property, which a failure or malfunction of our Products may cause. The following are examples of safety measures:
 - Installation of protection circuits or other protective devices to improve system safety
 - Installation of redundant circuits to reduce the impact of single or multiple circuit failure
- Our Products are designed and manufactured for use under standard conditions and not under any special or extraordinary environments or conditions, as exemplified below. Accordingly, ROHM shall not be in any way responsible or liable for any damages, expenses or losses arising from the use of any ROHM's Products under any special or extraordinary environments or conditions. If you intend to use our Products under any special or extraordinary environments or conditions (as exemplified below), your independent verification and confirmation of product performance, reliability, etc. prior to use, must be necessary:
 - Use of our Products in any types of liquid, including water, oils, chemicals, and organic solvents
 - Use of our Products outdoors or in places where the Products are exposed to direct sunlight or dust
 - Use of our Products in places where the Products are exposed to sea wind or corrosive gases, including Cl₂, H₂S, NH₃, SO₂, and NO₂
 - Use of our Products in places where the Products are exposed to static electricity or electromagnetic waves
 - Use of our Products in proximity to heat-producing components, plastic cords, or other flammable items
 - Sealing or coating our Products with resin or other coating materials
 - Use of our Products without cleaning residue of flux (Exclude cases where no-clean type fluxes is used. However, recommend sufficiently about the residue.) ; or Washing our Products by using water or water-soluble cleaning agents for cleaning residue after soldering
 - Use of the Products in places subject to dew condensation
- The Products are not subject to radiation-proof design.
- Please verify and confirm characteristics of the final or mounted products in using the Products.
- In particular, if a transient load (a large amount of load applied in a short period of time, such as pulse. is applied, confirmation of performance characteristics after on-board mounting is strongly recommended. Avoid applying power exceeding normal rated power; exceeding the power rating under steady-state loading condition may negatively affect product performance and reliability.
- De-rate Power Dissipation depending on ambient temperature. When used in sealed area, confirm that it is the use in the range that does not exceed the maximum junction temperature.
- Confirm that operation temperature is within the specified range described in the product specification.
- ROHM shall not be in any way responsible or liable for failure induced under deviant condition from what is defined in this document.

Precaution for Mounting / Circuit board design

- When a highly active halogenous (chlorine, bromine, etc.) flux is used, the residue of flux may negatively affect product performance and reliability.
- In principle, the reflow soldering method must be used on a surface-mount products, the flow soldering method must be used on a through hole mount products. If the flow soldering method is preferred on a surface-mount products, please consult with the ROHM representative in advance.

For details, please refer to ROHM Mounting specification

Precautions Regarding Application Examples and External Circuits

1. If change is made to the constant of an external circuit, please allow a sufficient margin considering variations of the characteristics of the Products and external components, including transient characteristics, as well as static characteristics.
2. You agree that application notes, reference designs, and associated data and information contained in this document are presented only as guidance for Products use. Therefore, in case you use such information, you are solely responsible for it and you must exercise your own independent verification and judgment in the use of such information contained in this document. ROHM shall not be in any way responsible or liable for any damages, expenses or losses incurred by you or third parties arising from the use of such information.

Precaution for Electrostatic

This Product is electrostatic sensitive product, which may be damaged due to electrostatic discharge. Please take proper caution in your manufacturing process and storage so that voltage exceeding the Products maximum rating will not be applied to Products. Please take special care under dry condition (e.g. Grounding of human body / equipment / solder iron, isolation from charged objects, setting of Ionizer, friction prevention and temperature / humidity control).

Precaution for Storage / Transportation

1. Product performance and soldered connections may deteriorate if the Products are stored in the places where:
 - [a] the Products are exposed to sea winds or corrosive gases, including Cl₂, H₂S, NH₃, SO₂, and NO₂
 - [b] the temperature or humidity exceeds those recommended by ROHM
 - [c] the Products are exposed to direct sunshine or condensation
 - [d] the Products are exposed to high Electrostatic
2. Even under ROHM recommended storage condition, solderability of products out of recommended storage time period may be degraded. It is strongly recommended to confirm solderability before using Products of which storage time is exceeding the recommended storage time period.
3. Store / transport cartons in the correct direction, which is indicated on a carton with a symbol. Otherwise bent leads may occur due to excessive stress applied when dropping of a carton.
4. Use Products within the specified time after opening a humidity barrier bag. Baking is required before using Products of which storage time is exceeding the recommended storage time period.

Precaution for Product Label

A two-dimensional barcode printed on ROHM Products label is for ROHM's internal use only.

Precaution for Disposition

When disposing Products please dispose them properly using an authorized industry waste company.

Precaution for Foreign Exchange and Foreign Trade act

Since concerned goods might be fallen under listed items of export control prescribed by Foreign exchange and Foreign trade act, please consult with ROHM in case of export.

Precaution Regarding Intellectual Property Rights

1. All information and data including but not limited to application example contained in this document is for reference only. ROHM does not warrant that foregoing information or data will not infringe any intellectual property rights or any other rights of any third party regarding such information or data.
2. ROHM shall not have any obligations where the claims, actions or demands arising from the combination of the Products with other articles such as components, circuits, systems or external equipment (including software).
3. No license, expressly or implied, is granted hereby under any intellectual property rights or other rights of ROHM or any third parties with respect to the Products or the information contained in this document. Provided, however, that ROHM will not assert its intellectual property rights or other rights against you or your customers to the extent necessary to manufacture or sell products containing the Products, subject to the terms and conditions herein.

Other Precaution

1. This document may not be reprinted or reproduced, in whole or in part, without prior written consent of ROHM.
2. The Products may not be disassembled, converted, modified, reproduced or otherwise changed without prior written consent of ROHM.
3. In no event shall you use in any way whatsoever the Products and the related technical information contained in the Products or this document for any military purposes, including but not limited to, the development of mass-destruction weapons.
4. The proper names of companies or products described in this document are trademarks or registered trademarks of ROHM, its affiliated companies or third parties.

General Precaution

1. Before you use our Products, you are requested to carefully read this document and fully understand its contents. ROHM shall not be in any way responsible or liable for failure, malfunction or accident arising from the use of any ROHM's Products against warning, caution or note contained in this document.
2. All information contained in this document is current as of the issuing date and subject to change without any prior notice. Before purchasing or using ROHM's Products, please confirm the latest information with a ROHM sales representative.
3. The information contained in this document is provided on an "as is" basis and ROHM does not warrant that all information contained in this document is accurate and/or error-free. ROHM shall not be in any way responsible or liable for any damages, expenses or losses incurred by you or third parties resulting from inaccuracy or errors of or concerning such information.



BD83070GWL - Web Page

[Distribution Inventory](#)

| | |
|-----------------------------|-------------------|
| Part Number | BD83070GWL |
| Package | UCSP50L1C (12Pin) |
| Unit Quantity | 3000 |
| Minimum Package Quantity | 3000 |
| Packing Type | Taping |
| Constitution Materials List | inquiry |
| RoHS | Yes |

Mouser Electronics

Authorized Distributor

Click to View Pricing, Inventory, Delivery & Lifecycle Information:

[ROHM Semiconductor:](#)

[BD83070GWL-E2](#)

Компания «Океан Электроники» предлагает заключение долгосрочных отношений при поставках импортных электронных компонентов на взаимовыгодных условиях!

Наши преимущества:

- Поставка оригинальных импортных электронных компонентов напрямую с производств Америки, Европы и Азии, а так же с крупнейших складов мира;
- Широкая линейка поставок активных и пассивных импортных электронных компонентов (более 30 млн. наименований);
- Поставка сложных, дефицитных, либо снятых с производства позиций;
- Оперативные сроки поставки под заказ (от 5 рабочих дней);
- Экспресс доставка в любую точку России;
- Помощь Конструкторского Отдела и консультации квалифицированных инженеров;
- Техническая поддержка проекта, помощь в подборе аналогов, поставка прототипов;
- Поставка электронных компонентов под контролем ВП;
- Система менеджмента качества сертифицирована по Международному стандарту ISO 9001;
- При необходимости вся продукция военного и аэрокосмического назначения проходит испытания и сертификацию в лаборатории (по согласованию с заказчиком);
- Поставка специализированных компонентов военного и аэрокосмического уровня качества (Xilinx, Altera, Analog Devices, Intersil, Interpoint, Microsemi, Actel, Aeroflex, Peregrine, VPT, Syfer, Eurofarad, Texas Instruments, MS Kennedy, Miteq, Cobham, E2V, MA-COM, Hittite, Mini-Circuits, General Dynamics и др.);

Компания «Океан Электроники» является официальным дистрибьютором и эксклюзивным представителем в России одного из крупнейших производителей разъемов военного и аэрокосмического назначения «JONHON», а так же официальным дистрибьютором и эксклюзивным представителем в России производителя высокотехнологичных и надежных решений для передачи СВЧ сигналов «FORSTAR».



JONHON

«JONHON» (основан в 1970 г.)

Разъемы специального, военного и аэрокосмического назначения:

(Применяются в военной, авиационной, аэрокосмической, морской, железнодорожной, горно- и нефтедобывающей отраслях промышленности)

«FORSTAR» (основан в 1998 г.)

ВЧ соединители, коаксиальные кабели,
кабельные сборки и микроволновые компоненты:

(Применяются в телекоммуникациях гражданского и специального назначения, в средствах связи, РЛС, а так же военной, авиационной и аэрокосмической отраслях промышленности).



Телефон: 8 (812) 309-75-97 (многоканальный)

Факс: 8 (812) 320-03-32

Электронная почта: ocean@oceanchips.ru

Web: <http://oceanchips.ru/>

Адрес: 198099, г. Санкт-Петербург, ул. Калинина, д. 2, корп. 4, лит. А