

L6472 Discovery: development tool to explore L6472 motor driver

Data brief

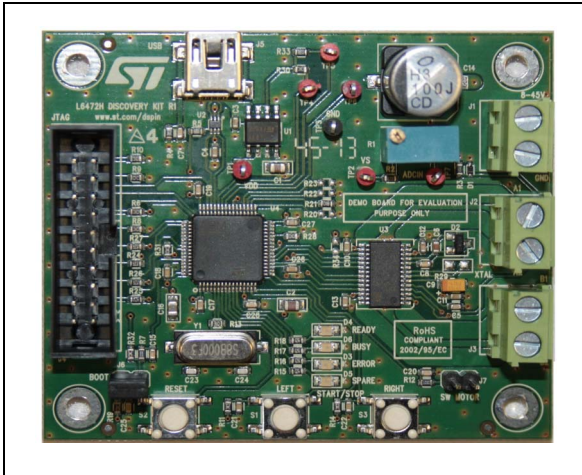

Description

The L6472 Discovery is a low cost development tool to explore the L6472 motor driver.

An ideal starter-kit for both beginners and experienced users, it is autonomous and can be used with a software interface or with a custom firmware thanks to the embedded microcontroller.

Through the available GUI the user can easily set the full configuration of application parameters.

“Plug and Play” tool it offers high motor control flexibility thanks to the wide operating voltage range from 8 V to 45 V and the current capability up to 3 A_{r.m.s.}. It is equipped with LED indicators for specific ready, busy, error warning.

Features

- STMicroelectronics® patented advanced current control
- Fully autonomous solution embedding an STM32™ MCU and the L6472 stepper motor driver
- Compatible with SPIN family evaluation software
- Wide voltage range from 8 V to 45 V
- High phase current up to 3 A_{r.m.s.}
- Footprint for external resonator or crystal
- Switch motor input control
- Keys start/left - stop/right - reset
- Ready, busy, error LED indicators
- Spare LED indicators for specific design
- Adjustable supply voltage compensation
- Up to 1/16 microstepping

Board description

Table 1. Electrical specifications

Parameter	Value
Supply voltage (V_S)	8 to 45 V
Maximum output current (each phase)	3 A _{r.m.s}
Logic supply voltage (V_{REG})	3 V (internal supply)
Logic interface voltage (V_{DD})	3.3 V (internal supply)
Low level logic inputs voltage	0 V
High level logic input voltage	V_{DD}
Stepping	Up to 1/16 microstepping
Operating temperature	-25 to 125 °C

Figure 1. Jumper and connector locations

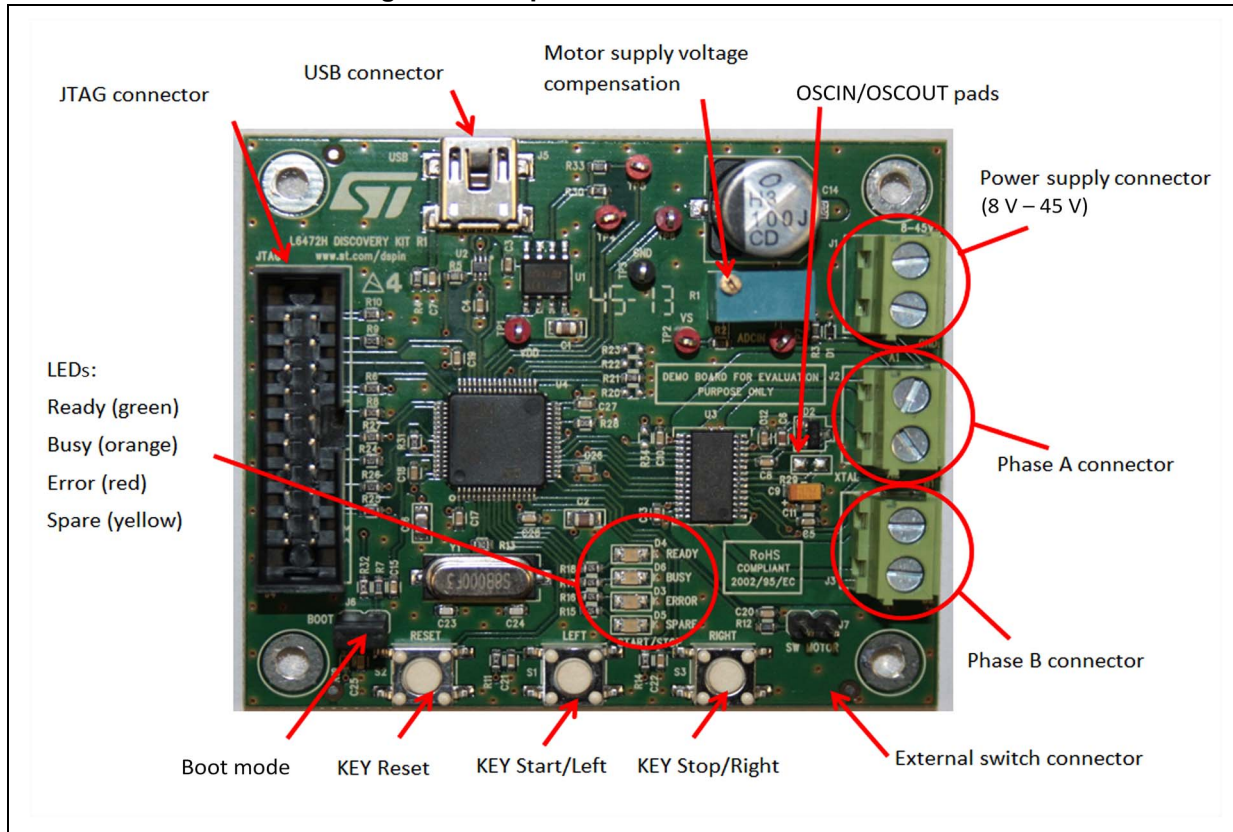

Table 2. Jumpers and connectors

Name	Function
J1	Motor supply voltage
J2	Bridge B output
J3	Bridge A output
J4	Debug JTAG function
J5	USB function
J6	Boot mode
J7	External switch input
R29	OSCIN and OUSCOUT pins
TP1	V _{DD} - logic supply voltage
TP2	V _S - motor supply voltage
TP3	GND - ground test point
TP4	UART RX - debug test point
TP5	UART TX - debug test point
TP6	UART CK - debug test point
TP7	Motor voltage compensation test point

Table 3. JTAG connector pinout (J4)

Name	Type	Function
1-2	Supply	EXT_VDD
3	Digital I/O	External RESET
5	Digital I/O	INPUT (TDI)
7	Digital I/O	Mode select (TMS)
9	Digital I/O	Clock (TCK)
13	Digital I/O	OUTPUT (TDO)
15	Digital I/O	Internal RESET
11 - 17 - 19	Digital I/O	Pull down
4 - 6 - 8 - 10 - 12 - 14 - 16 - 18 - 20	Ground	Ground

Figure 2. Schematic (microcontroller control part)

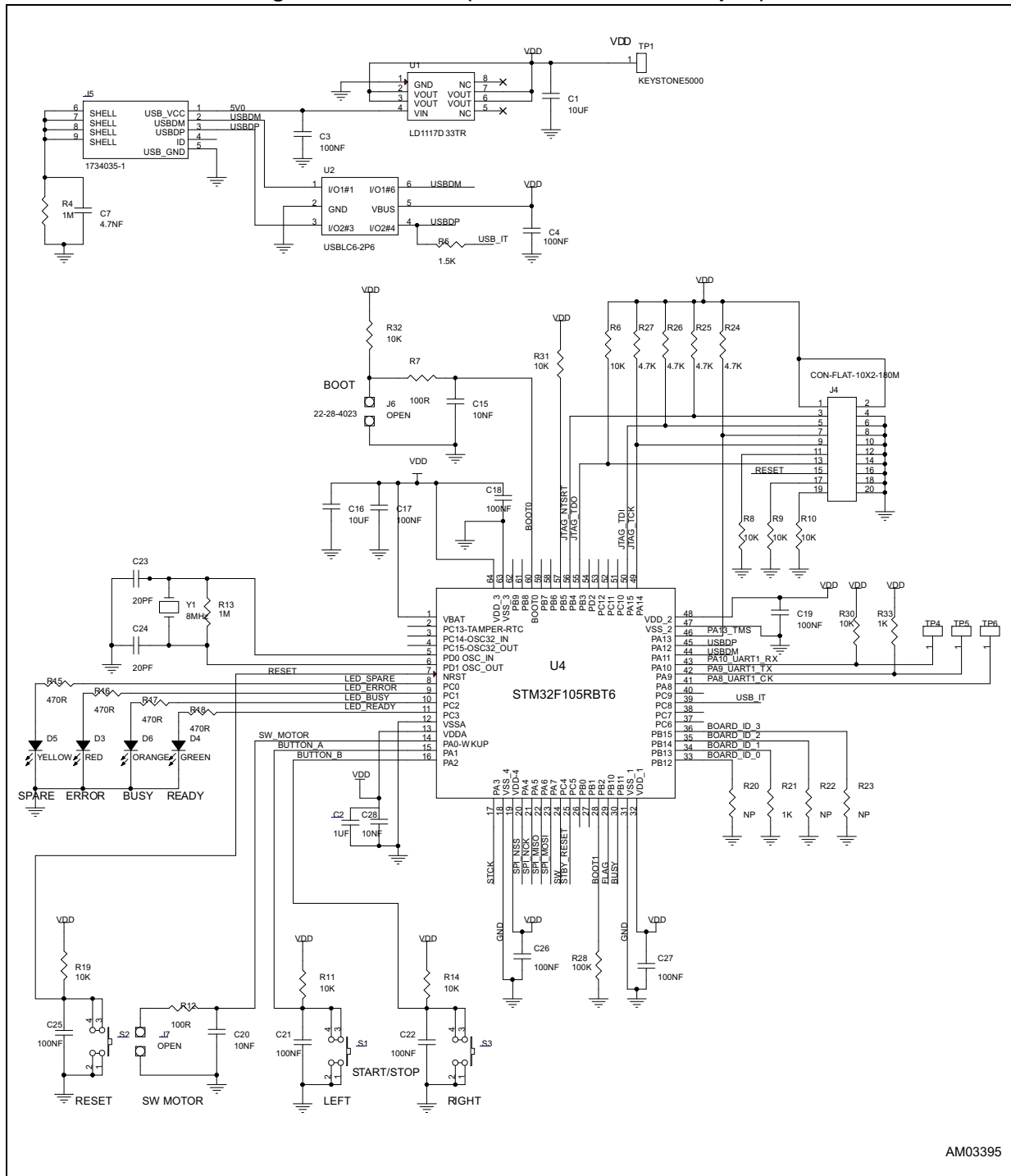

AM03395

Figure 3. Schematic (motion control part)

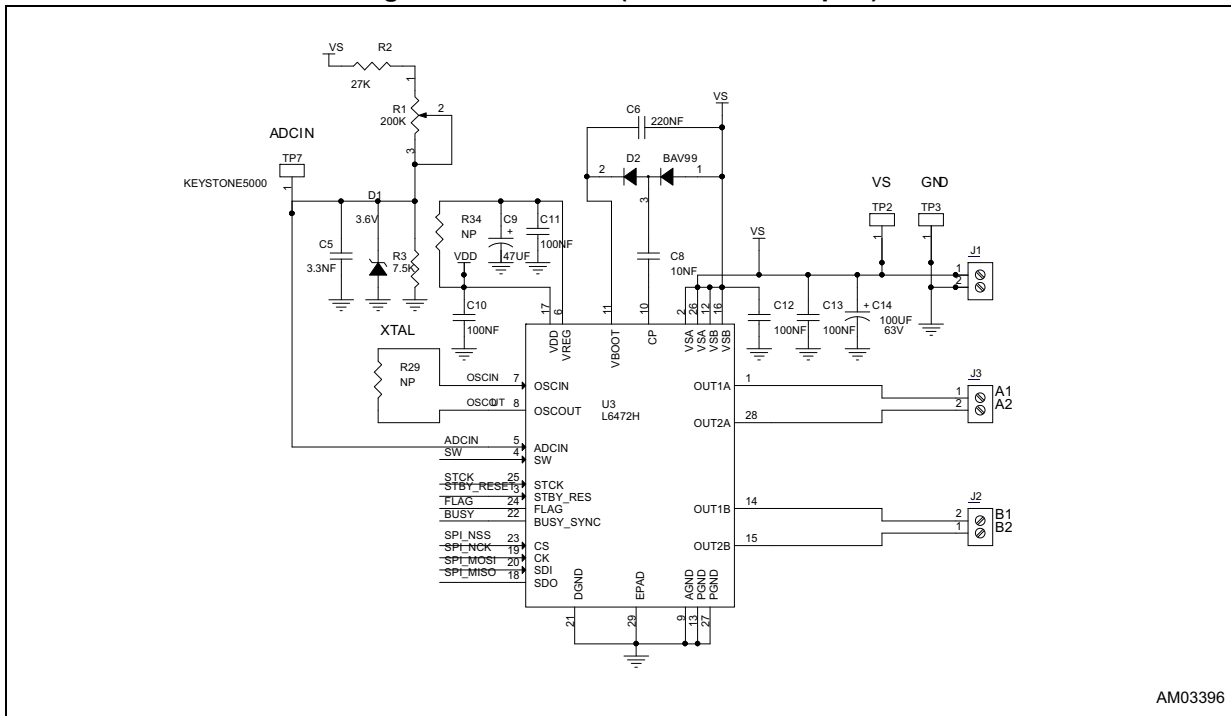

AM03396

Table 4. Bill of material

Item	Quantity	Reference	Value	Package
C1, C16	2	Cap. cer. 10 μ F 10 V X7R 0805	10 μ F	0805
C2	1	Cap. cer. 1 μ F 10 V X7R 0805	1 μ F	0805
C3, C4, C10 - C13, C17 - C19, C21, C22, C25 - C27	14	Cap. cer. 100 nF 50 V X7R 0603	100 nF	0603
C5	1	Cap. cer. 3.3 nF 50 V X7R 0603	3.3 nF	0603
C6	1	Cap. cer. 220 nF 35 V X7R 0603	220 nF	0603
C7	1	Cap. cer. 4.7 nF 50 V X7R 0603	4.7 nF	0603
C8, C15, C20, C28	4	Cap. cer. 10 nF 50 V X7R 0603	10 nF	0603
C9	1	Cap. tant. 47 μ F 6.3 V 10% PACK-A	47 μ F	3216
C14	1	Cap. elect. 100 μ F 63 V	100 μ F	CAPES-R10HXX
C23, C24	2	Cap. cer. 20 pF 50 V COG 0603	20 pF	0603
D1	1	Zener regulator	3.6 V	SOD 523
D2	1	Double diode high speed switching diode	BAV99	SOT23
D3	1	LED red - 0805 -2 mcd - 621 nm	Red	0805
D4	1	LED green - 0805 - 6 mcd - 569 nm	Green	0805
D5	1	LED yellow - 0805 -6 mcd - 588 nm	Yellow	0805
D6	1	LED orange - 0805 -2 mcd - 602 nm	Orange	0805
FIX1 - FIX4	4	Hole		-
J1 - J3	3	Screw connector 2 poles MKDSN 1.5 / 2 - 5.08	MKDSN1.5 / 2 - 5.08	MKDSN1.5 / 2 - 5.08
J4	1	JTAG CON-FLAT-10 x 2 - 180 M	CON-FLAT-10 x 2 - 180 M	CON-FLAT-10 x 2 -180 M
J5	1	USB_B_MINI_AMP_1734035-1	CN-USB	CMS mini-USB
J6, J7	2	JUMP254P-M-2	Open	Strip 2 x 2.54
MIRE1 - MIRE3	3	OPTICAL_TARGET	OPTICAL_TARGET	Diam. 1 mn
R1	1	Trimmer 200 K Ω	200 K Ω	Trimm. 100 x 50 x 110
R2	1	27 K Ω 5% 1/10 W	27 K Ω	0603
R3	1	Res. 7.5 K Ω 5% 1/10 W 0603 SMD	7.5 K Ω	0603
R4, R13	2	Res. 1 M Ω 1/10 W 5% 0603 SMD	1 M Ω	0603

Table 4. Bill of material (continued)

Item	Quantity	Reference	Value	Package
R5	1	Res. 1.5 K Ω 1/10 W 5% 0603 SMD	1.5 K Ω	0603
R6, R8 - R11, R14, R19, R30 - R32	10	Res. 10 K Ω 5% 1/10W 0603 SMD	10 K Ω	0603
R7, R12	2	Res. 100 Ω 5% 1/10 W	100 Ω	0603
R15 - R18	4	Res. 470 Ω 5% 1/10 W 0603	470 Ω	0603
R20, R22, R23, R34	4	Res. NP 0603	NP	0603
R21, R33	2	Res. 1 K Ω 5% 1/10 W 0603 SMD	1 K Ω	0603
R24 - R27	4	Res. 4.7 K Ω 5% 1/10 W 0603 SMD	4.7 K Ω	0603
R28	1	Res. 100 K Ω 5% 1/10 W 0603 SMD	100 K Ω	0603
R29	1	Res. NP 0805	NP	0805
S1-S3	3	Switch button SMD	EVQQ2D03W	CMS 6.5 x 6 x 3.1
TP1, TP2, TP4 - TP7	6	Test point red	Keystone - 5000	TH
TP3	1	Test point black	Keystone - 5001	TH
U1	1	IC reg. 1300 MA LN 3.3 V	LD1117D33TR	SO8
U2	1	UBSLC6-2P6 - ESD protection low capacitance	USBLC6-2P6	SOT 666
U3	1	L6472 motor driver	L6472H	HTSSOP28
U4	1	IC, MCU, RISC, 72 MHz, 3.6 V, 32-bit, 64-pin, LQFP	STM32F105RBT6	LQFP64 10 x 10
Y1	1	Xtal 8 MHz - 30 PPM - 20 pF	8 MHz	HC49/US-SM

Figure 4. Layout (top layer)

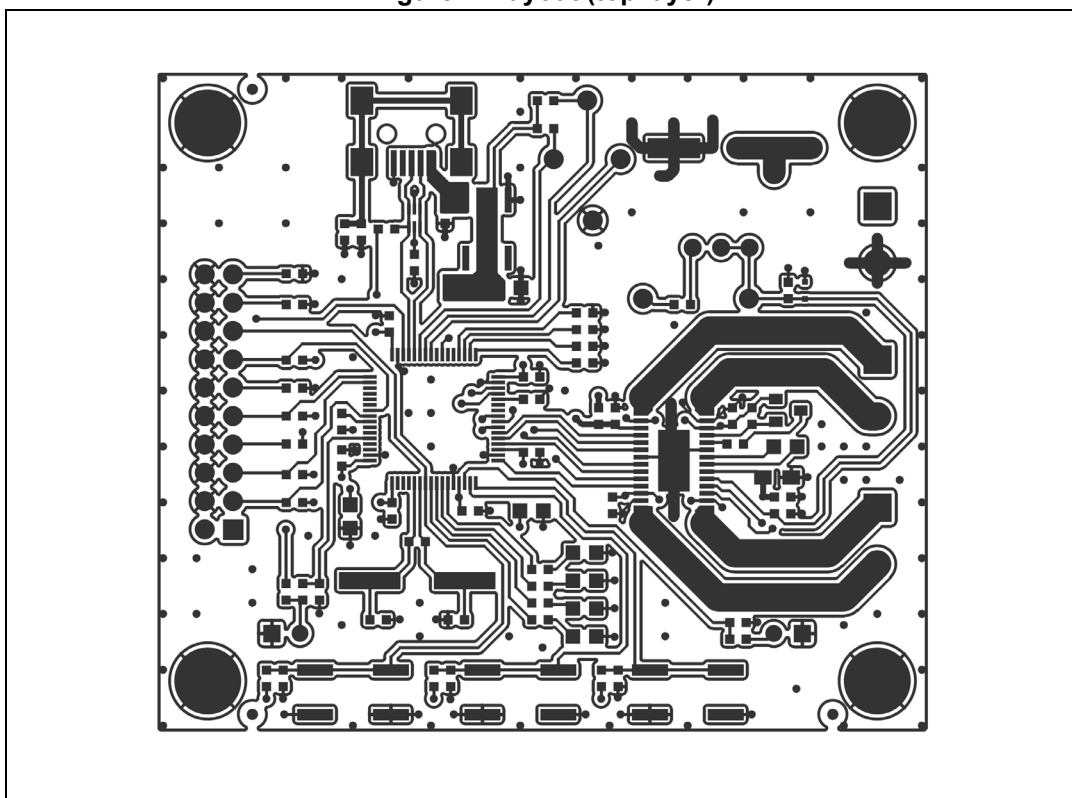
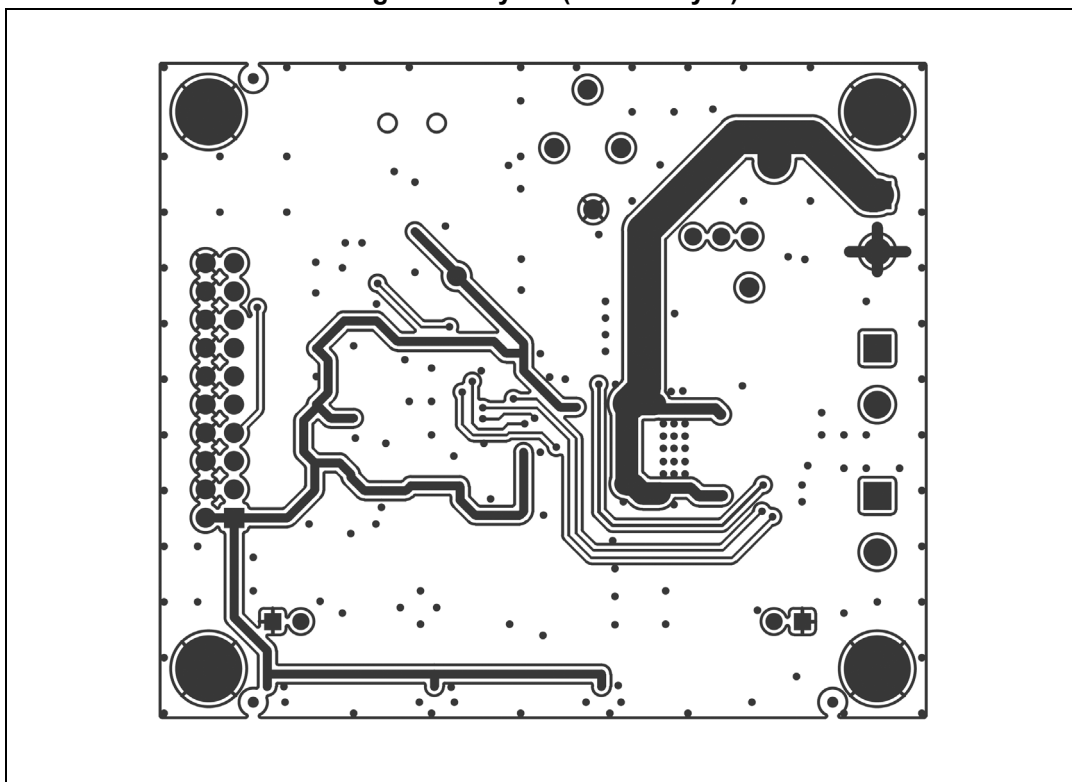

Figure 5. Layout (bottom layer)



1 Revision history

Table 5. Document revision history

Date	Revision	Changes
30-Oct-2013	1	Initial release.
29-Nov-2013	2	Updated board photography on page 1. Updated Figure 1 on page 2 (updated board photography). Minor modifications throughout document.
17-Jan-2014	3	Updated main title on page 1 (replaced “dSPIN™ Discovery L6472” by “dSPIN™ Discovery: development tool to explore dSPIN™ (L6472) motor driver”). Updated Section : Features on page 1 (replaced whole original Section by new Features). Updated Section : Description on page 1 (replaced original Section by new Description). Minor modifications throughout document.
17-Mar-2015	4	Updated main title on on page 1 (removed dSPIN™). Updated Section : Features on page 1 (replaced L6470H by L6472H). Updated Section : Description on page 1 (replaced dSPIN™ by L6472H). Updated Table 4 on page 6 (U3, column Reference: “L6472 motor driver” instead of “dSPIN microstepping motor driven”). Removed Figure 4. Layout (silk screen) from page 8.

IMPORTANT NOTICE – PLEASE READ CAREFULLY

STMicroelectronics NV and its subsidiaries ("ST") reserve the right to make changes, corrections, enhancements, modifications, and improvements to ST products and/or to this document at any time without notice. Purchasers should obtain the latest relevant information on ST products before placing orders. ST products are sold pursuant to ST's terms and conditions of sale in place at the time of order acknowledgement.

Purchasers are solely responsible for the choice, selection, and use of ST products and ST assumes no liability for application assistance or the design of Purchasers' products.

No license, express or implied, to any intellectual property right is granted by ST herein.

Resale of ST products with provisions different from the information set forth herein shall void any warranty granted by ST for such product.

ST and the ST logo are trademarks of ST. All other product or service names are the property of their respective owners.

Information in this document supersedes and replaces information previously supplied in any prior versions of this document.

© 2015 STMicroelectronics – All rights reserved

Компания «Океан Электроники» предлагает заключение долгосрочных отношений при поставках импортных электронных компонентов на взаимовыгодных условиях!

Наши преимущества:

- Поставка оригинальных импортных электронных компонентов напрямую с производств Америки, Европы и Азии, а так же с крупнейших складов мира;
- Широкая линейка поставок активных и пассивных импортных электронных компонентов (более 30 млн. наименований);
- Поставка сложных, дефицитных, либо снятых с производства позиций;
- Оперативные сроки поставки под заказ (от 5 рабочих дней);
- Экспресс доставка в любую точку России;
- Помощь Конструкторского Отдела и консультации квалифицированных инженеров;
- Техническая поддержка проекта, помощь в подборе аналогов, поставка прототипов;
- Поставка электронных компонентов под контролем ВП;
- Система менеджмента качества сертифицирована по Международному стандарту ISO 9001;
- При необходимости вся продукция военного и аэрокосмического назначения проходит испытания и сертификацию в лаборатории (по согласованию с заказчиком);
- Поставка специализированных компонентов военного и аэрокосмического уровня качества (Xilinx, Altera, Analog Devices, Intersil, Interpoint, Microsemi, Actel, Aeroflex, Peregrine, VPT, Syfer, Eurofarad, Texas Instruments, MS Kennedy, Miteq, Cobham, E2V, MA-COM, Hittite, Mini-Circuits, General Dynamics и др.);

Компания «Океан Электроники» является официальным дистрибьютором и эксклюзивным представителем в России одного из крупнейших производителей разъемов военного и аэрокосмического назначения «JONHON», а так же официальным дистрибьютором и эксклюзивным представителем в России производителя высокотехнологичных и надежных решений для передачи СВЧ сигналов «FORSTAR».



JONHON

«JONHON» (основан в 1970 г.)

Разъемы специального, военного и аэрокосмического назначения:

(Применяются в военной, авиационной, аэрокосмической, морской, железнодорожной, горно- и нефтедобывающей отраслях промышленности)

«FORSTAR» (основан в 1998 г.)

ВЧ соединители, коаксиальные кабели,
кабельные сборки и микроволновые компоненты:

(Применяются в телекоммуникациях гражданского и специального назначения, в средствах связи, РЛС, а так же военной, авиационной и аэрокосмической отраслях промышленности).



Телефон: 8 (812) 309-75-97 (многоканальный)

Факс: 8 (812) 320-03-32

Электронная почта: ocean@oceanchips.ru

Web: <http://oceanchips.ru/>

Адрес: 198099, г. Санкт-Петербург, ул. Калинина, д. 2, корп. 4, лит. А